

# Service Manual

Fully Automatic Turntable System

Turntable System  
**SL-BD35**



**Color**

(S)...Silver Type

**Area**

[M].....U.S.A.

**TAP** is the standard mark for the "P-mount" plug-in-connector system. Products carrying this mark are interchangeable and compatible with each other.

## SPECIFICATIONS

### ■ Turntable section

**Type:** Fully automatic turntable  
**Features:** Auto start  
 Auto return  
 Auto stop  
 Repeat play  
 Manual play  
**Drive method:** Belt drive  
**Motor:** DC motor  
**Drive control method:** Frequency generator  
 servo control  
**Turntable platter:** Aluminum die-cast  
 Diameter 31.2 cm (12-9/32")  
**Turntable speeds:** 33-1/3 rpm and 45 rpm  
**Wow and flutter:** 0.045% WRMS (JIS C5521)  
 ±0.06% peak  
 (IEC 98A Weighted)  
**Rumble:** -70 dB (IEC 98A Weighted)

### ■ Tonearm section

**Type:** Statically-balanced straight  
 tonearm  
 Plug-in connector cartridge  
 system  
**Effective length:** 230 mm (9-1/16")  
**Overhang:** 15 mm (19/32")

**Tracking error angle:** Within 2°32' at the outer groove  
 of 30 cm (12") record  
 Within 0°32' at the inner groove  
 of 30 cm (12") record  
**Effective mass:** 13.5 g (including cartridge)  
**Stylus pressure:** 1.25 g (Fixed)  
**Applicable cartridge  
 weight:** 6 g  
**Phono cable  
 capacitance:** 90 pF

### ■ General

**Power supply:** 120 V AC, 60 Hz  
**Power consumption:** 8W  
**Dimensions:** 43 × 10 × 37.5 cm  
 (16-15/16" × 3-15/16" × 14-3/4")  
 Maximum height when  
 dust cover is open.  
 43 × 37 × 41 cm  
 (16-15/16" × 14-9/16" × 16-1/8")  
**Weight:** 3.8 kg (8.4 lb.)

Specifications subject to change without notice for further improvement.  
 Weight and dimensions shown are approximate.

# Technics

Matsushita Engineering and  
 Service Company  
 50 Meadowland Parkway,  
 Secaucus, New Jersey 07094

Panasonic Hawaii Inc.  
 91-238 Kauhū St. Ewa Beach  
 P.O. Box 774  
 Honolulu, Hawaii 96808-0774

Panasonic Sales Company,  
 Division of Matsushita Electric  
 of Puerto Rico, Inc.  
 Ave. 65 De Infantería, KM 9.7  
 Victoria Industrial Park  
 Carolina, Puerto Rico 00630

## CONTENTS

	Page
SAFETY PRECAUTION .....	2
LOCATION OF CONTROLS .....	3
DISASSEMBLY INSTRUCTIONS .....	3 ~ 5
MEASUREMENTS AND ADJUSTMENTS .....	6, 7
TROUBLESHOOTING .....	7, 8
SCHEMATIC DIAGRAM .....	9, 10
BLOCK DIAGRAM .....	9
CIRCUIT BOARD AND WIRING CONNECTION DIAGRAM .....	11
OPERATIONAL DESCRIPTION OF MECHANISM .....	11 ~ 13
EXPLODED VIEW .....	14 ~ 16
REPLACEMENT PARTS LIST .....	17, 18

## SAFETY PRECAUTION

1. Before servicing, unplug the power cord to prevent an electric shock.
2. When replacing parts, use only manufacturer's recommended components for safety.
3. Check the condition of the power cord. Replace if wear or damage is evident.
4. After servicing, be sure to restore the lead dress, insulation barriers, insulation papers, shields, etc.
5. Before returning the serviced equipment to the customer, be sure to make the following insulation resistance test to prevent the customer from being exposed to a shock hazard.

### INSULATION RESISTANCE TEST

1. Unplug the power cord and short the two prongs of the plug with a jumper wire.
2. Turn on the power switch.
3. Measure the resistance value with ohmmeter between the jumpered AC plug and each exposed metal cabinet part, such as screwheads antenna, control shafts, handle brackets, etc. Equipment with antenna terminals should read between  $3M\Omega$  and  $5.2M\Omega$  to all exposed parts. (Fig. A) Equipment without antenna terminals should read approximately infinity to all exposed parts. (Fig. B)

**Note:** Some exposed parts may be isolated from the chassis by design. These will read infinity.

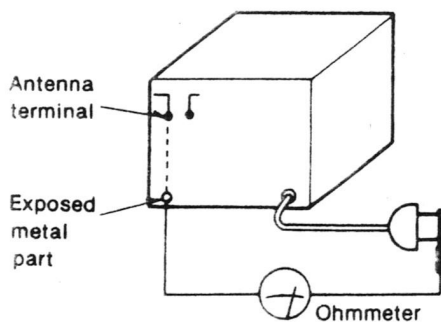

(Fig. A)

Resistance =  $3M\Omega - 5.2M\Omega$

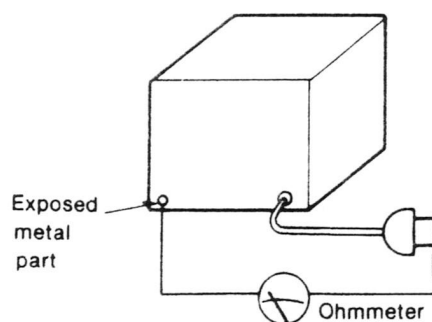

(Fig. B)

Resistance = Approx  $\infty$

4. If the measurement is outside the specified limits, there is a possibility of a shock hazard. The equipment should be repaired and rechecked before it is returned to the customer.

## LOCATION OF CONTROLS

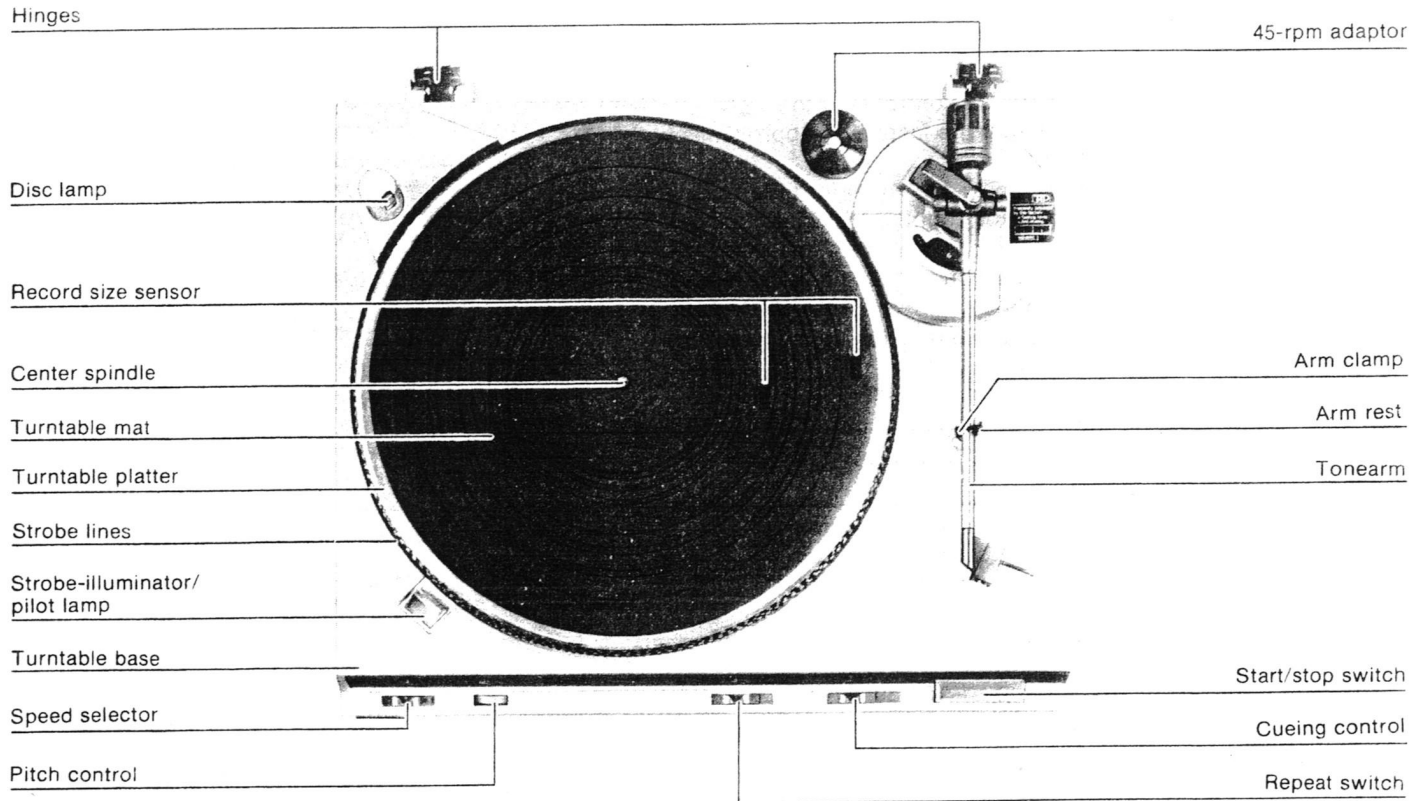

## DISASSEMBLY INSTRUCTIONS

Ref. No 1	How to remove the cartridge	Ref. No 3	How to remove the turntable platter
<b>Procedure 1</b>	<ol style="list-style-type: none"> <li>1. Remove the setscrew <b>1</b>.</li> <li>2. Pull out the cartridge, taking care that your hand does not touch the stylus tip.</li> </ol>	<b>Procedure 3</b>	<ol style="list-style-type: none"> <li>1. Open the dust cover and remove the turntable mat.</li> <li>2. Remove the belt</li> <li>3. Lift up the turntable platter.</li> </ol>
	<p>Cartridge</p>		<p>Dust cover</p> <p>Turntable mat</p> <p>Belt</p> <p>Turntable Platter</p>
<b>Ref. No 2</b>	<b>How to remove the stylus</b>		
<b>Procedure 2</b>	<ul style="list-style-type: none"> <li>• Pull out the stylus, taking care not to touch the stylus tip.</li> </ul>		
	<p>Cartridge</p> <p>Stylus</p>		

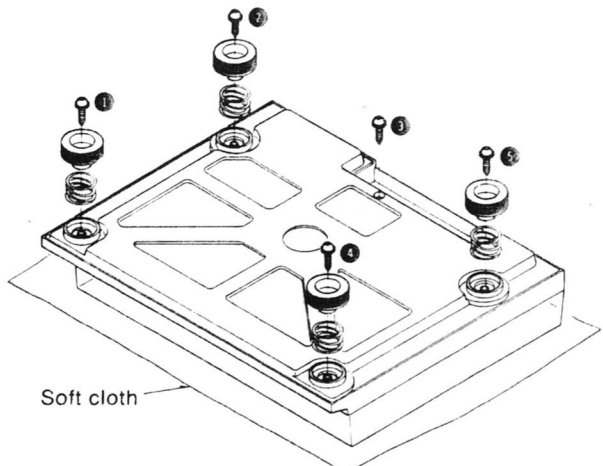
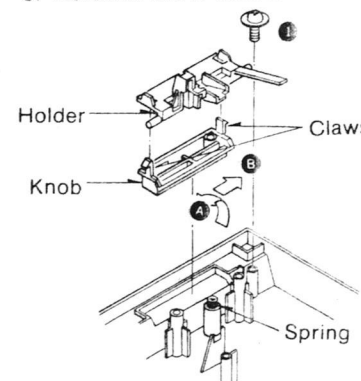
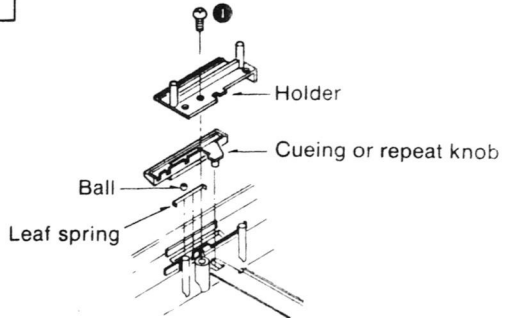
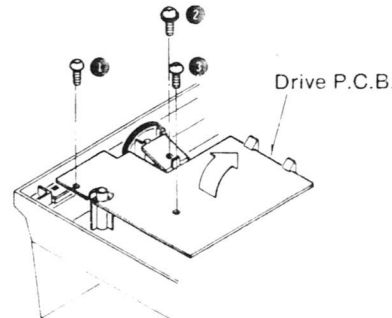
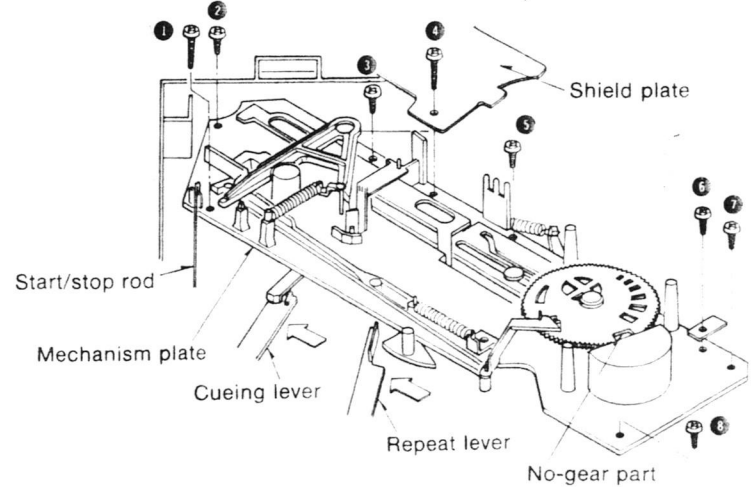
<p><b>Ref. No</b> 4</p>	<p><b>How to remove the bottom board</b></p>	<p><b>Ref. No</b> 6</p>	<p><b>How to remove the start/stop knob</b></p>
<p><b>Procedure</b> 3 ▶ 4</p>	<p>1. Turn over the unit on a soft cloth. 2. Remove the 5 setscrews (1 ~ 5)</p>	<p><b>Procedure</b> 3 ▶ 4 ▶ 6</p>	<p>1. Remove the setscrew 1. 2. Remove the holder (with knob) in the direction of the arrows (A, B). 3. Release the 2 claws.</p>
 <p>Soft cloth</p>		 <p>Holder Claws Knob Spring</p> <p><b>Note:</b> When attaching the start/stop knob, do not forget to attach the spring.</p>	
<p><b>Ref. No</b> 5</p>	<p><b>How to remove the cueing and repeat knob</b></p>	<p><b>Ref. No</b> 7</p>	<p><b>How to remove the drive P.C.B.</b></p>
<p><b>Procedure</b> 3 ▶ 4 ▶ 5</p>	<p>• Remove the setscrew 1.</p>	<p><b>Procedure</b> 3 ▶ 4 ▶ 7</p>	<p>1. Remove the 3 setscrews (1 ~ 3). 2. Remove the drive P.C.B. in the direction of the arrow.</p>
 <p>Holder Cueing or repeat knob Ball Leaf spring</p> <p><b>Caution:</b> When removing the cueing and repeat knob, please note the ball bearing which is held between the leaf spring and knob and take care not to drop or lose it.</p>		 <p>Drive P.C.B.</p>	
<p><b>Ref. No</b> 8</p>	<p><b>How to remove the mechanism plate</b></p>		
<p><b>Procedure</b> 3 ▶ 4 ▶ 8</p>	<p>1. Release the start/stop rod. 2. Remove the 8 setscrews. (1 ~ 8) 3. Lift up the mechanism plate.</p>		
<p><b>Note:</b> When fitting the mechanism plate, check the following points.</p> <ul style="list-style-type: none"> <li>• Turn the main gear until it comes to the no gear part.</li> <li>• Shift the cueing and repeat lever plates in the direction of the arrow.</li> </ul>		 <p>Start/stop rod Mechanism plate Cueing lever Repeat lever Shield plate No-gear part</p>	

**Ref. No**  
9

**How to remove the tonearm**

**Procedure**  
3♦4♦8♦9

1. Unsolder the 5 PU lead wires from the phono terminal.
  2. Remove the spring holder.
  3. Remove the setscrew ①.
  4. To remove the tonearm, remove the 2 setscrews (②, ③).
  5. To remove the arm base, remove the 2 setscrews (④, ⑤).
- \* PU lead wiring method  
 White .....L channel (+) terminal  
 Blue .....L channel (-) terminal  
 Red .....R channel (+) terminal  
 Green .....R channel (-) terminal  
 Black .....Ground terminal

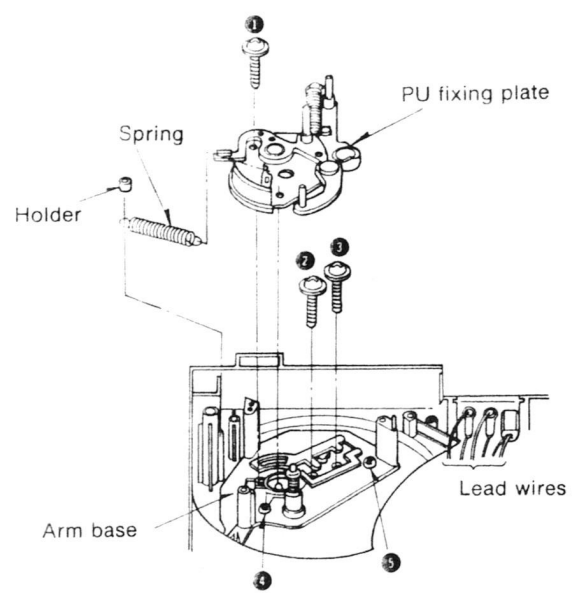

**Ref. No**  
10

**How to remove the cueing cam**

**Procedure**  
3♦4♦8♦10

1. Release the 2 claws with a driver.
2. Remove the washer.
3. Pull out the cueing cam.

**Note:**  
 If the cueing time of the tonearm becomes too short, or if the cueing cam is replaced, apply silicon oil (Part No. SZZ0L12) according to the following procedure.  
 1. Remove the cueing cam.  
 2. Apply silicon oil to the cueing cam and oil tank.

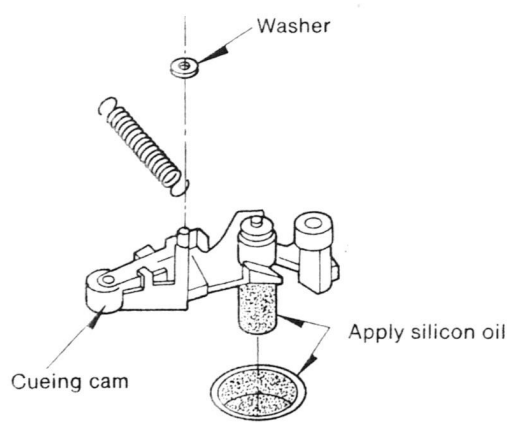
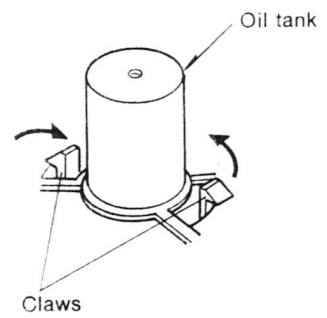

**Ref. No**  
11

**How to remove the magnetic resistor element**

**Procedure**  
3♦4♦11

1. Remove the motor assembly in the direction of the arrow.
2. Unsolder the 3 lead wires from the magnetic resistor P.C.B.

1. Release the claw and pull out the P.C.B.
2. Unsolder the 3 terminals of the magnetic resistor element.

**Note:**  
 If the magnetic resistor element has been replaced, observe the following mounting precaution.  
 •The magnetic resistor element is supplied with the center lead bent. Be sure the seat the bent lead flush to the P.C.B.  
 •This will ensure the proper clearance ( $1\pm 0.5\text{mm}$ ) between the magnet and the magnetic resistor element as shown below.

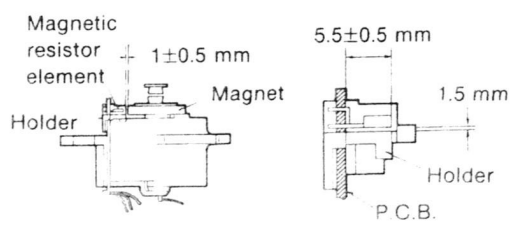
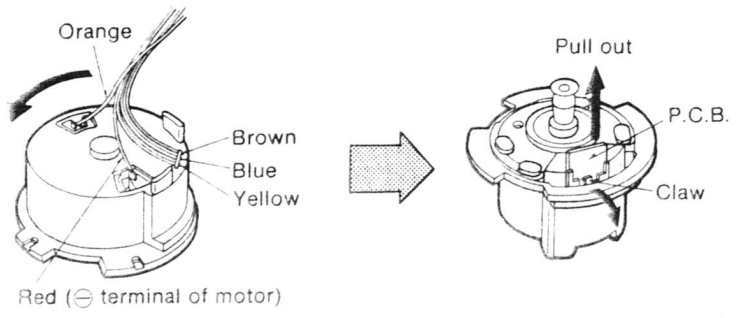

## MEASUREMENTS AND ADJUSTMENTS

### • Arm-lift height adjustment

The arm-lift height (distance between the stylus tip and the record surface when the cueing control is at the "∇" position) has been adjusted at the factory to approximately 5 to 7 mm (3/16"–9/32").

If the clearance is too narrow or too wide, turn the adjustment screw clockwise or counterclockwise.

#### **Clockwise rotation**

—distance between the record and stylus tip is decreased.

#### **Counterclockwise rotation**

—distance between the record and stylus tip is increased.

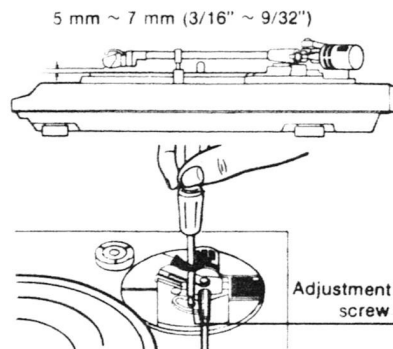

### • Automatic start position

If the stylus does not land in the lead-in groove, adjust as follows.

1. Clamp the tonearm to the arm rest.
2. Remove the rubber cap.
3. Turn the screw with a screwdriver, clockwise or counterclockwise as necessary.

If the stylus tip sets down too far in the recorded groove,

—turn **counterclockwise**.

If the stylus tip sets down outside of the record,

—turn **clockwise**.

Adjust so the stylus tip lands 1 ~ 2 mm in from the edge of the record.

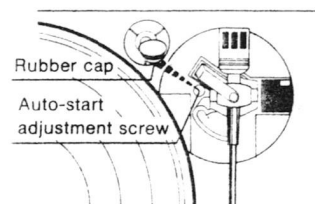

### • Automatic return position

(Remove the rubber cap.)

1. Put the stylus protector on the cartridge.
2. Move the tonearm toward the center of the record.

The auto-return adjustment screw will appear.

If the tonearm tends to return to the arm rest before the play has finished,

—turn **counterclockwise**.

If the tonearm fails to return after the final groove,

—turn **clockwise**.

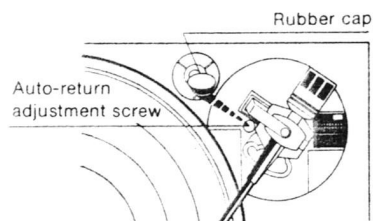

### • Speed adjustment (pitch control)

There are strobe-lines cut on this turntable platter to indicate correct rotational speed.

If the strobe-line appears to be moving as the turntable rotates, adjust while playing a record.

1. Set the speed selector to the speed to be adjusted.
2. Push the power switch. The strobe-illuminator/pilot lamp will light up and the platter will rotate.
3. Watch the dot pattern on the side of the platter. Turn the pitch control one way or the other until the dots appear to stand still. This is the correct speed.
4. Turning the pitch control in the "+" direction increases the speed.
5. Turning the pitch control in the "-" direction decreases the speed.

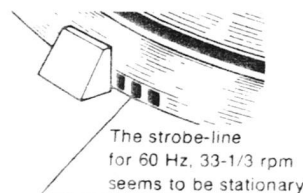
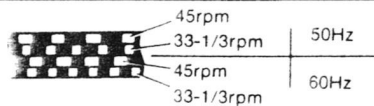

In the U.S.A. and CANADA use 60 Hz lines.  
The 50 Hz lines are for European countries.

• Rotating speed

When the turntable drive/control IC (IC101) or the variable resistors (VR101, 102) are changed, or if the rated rotation is not reached even when the pitch control knob is turned, adjust the rotating speed in the following procedure.

1. Set the speed selector switch to the "45" position.
2. Turn VR101 with a screwdriver from the bottom of the set to the rated rotation (45 rpm) and check the rotation with a strobe while adjusting the speed.
3. Set the speed selector switch to the "33" position.
4. Turn VR102 with a screwdriver from the bottom of the set to the rated rotation (33-1/3 rpm) and check the rotation with a strobe while adjusting the speed.

**Note:** Be sure to make the adjustment for 45 rpm first.

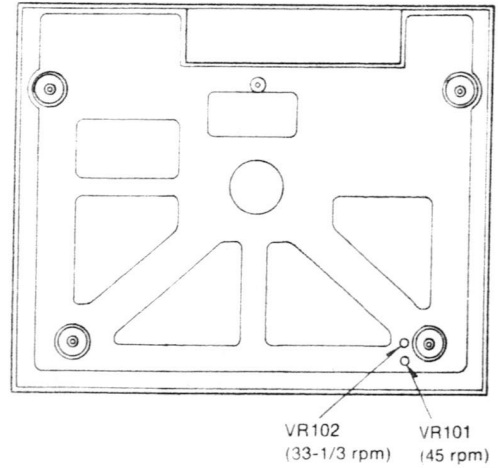

## ■ TROUBLESHOOTING

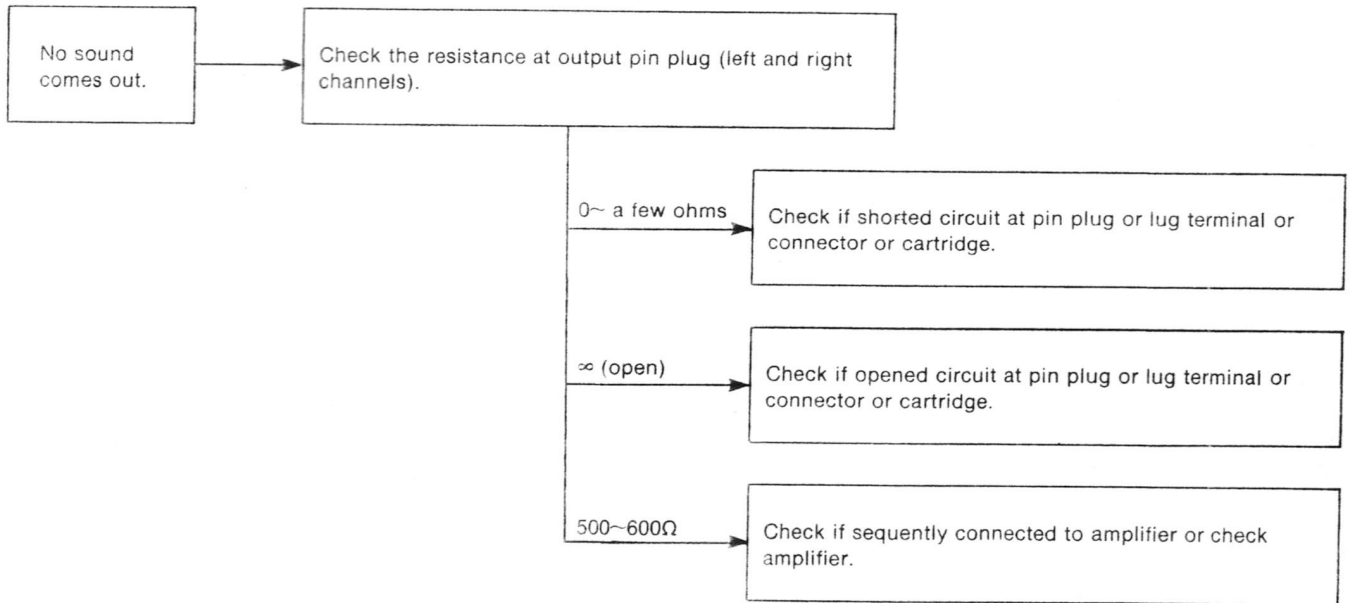

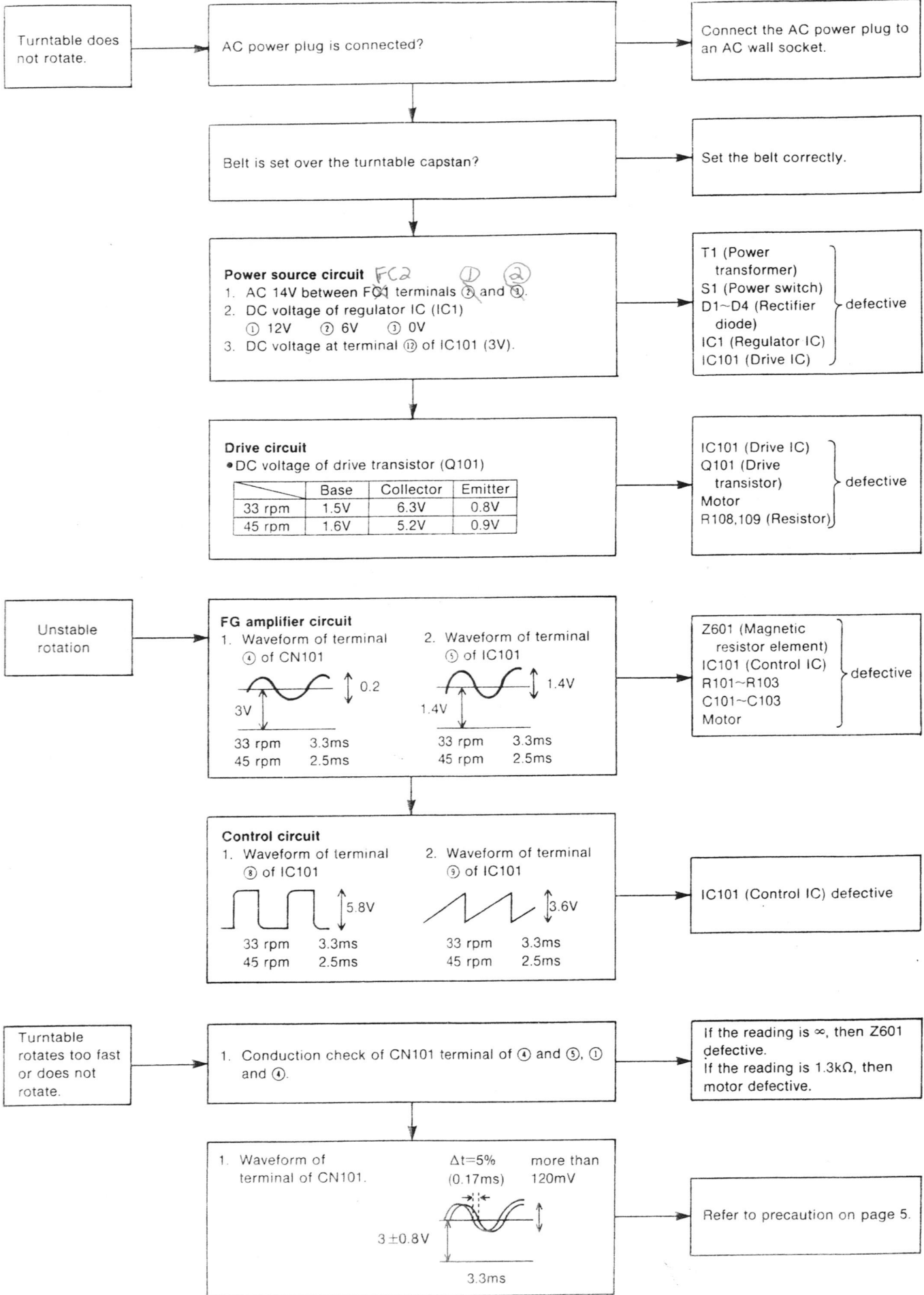

**SCHEMATIC DIAGRAM** (This schematic diagram may be modified at any time with development of new technology.)

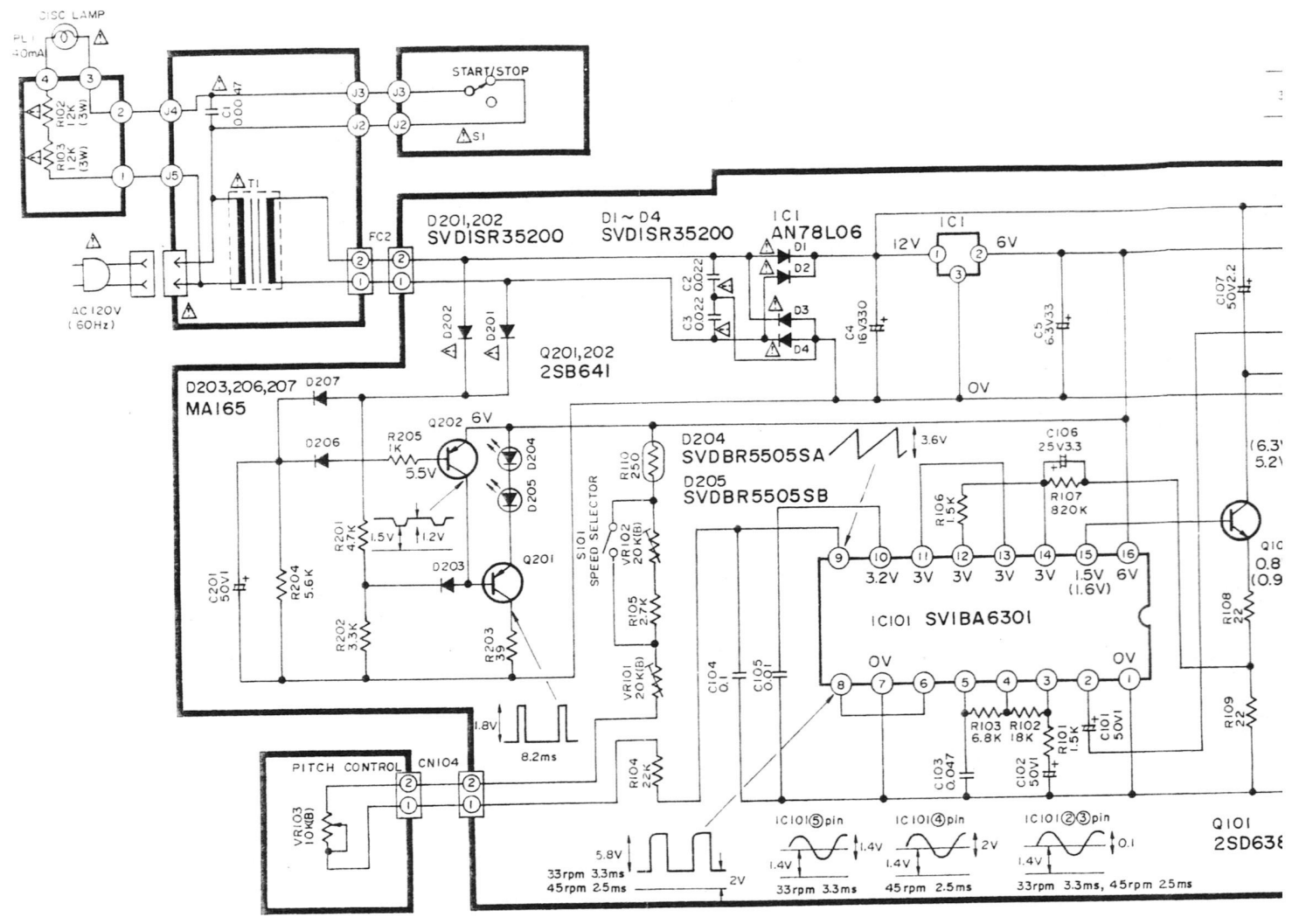

**BLOCK DIAGRAM**

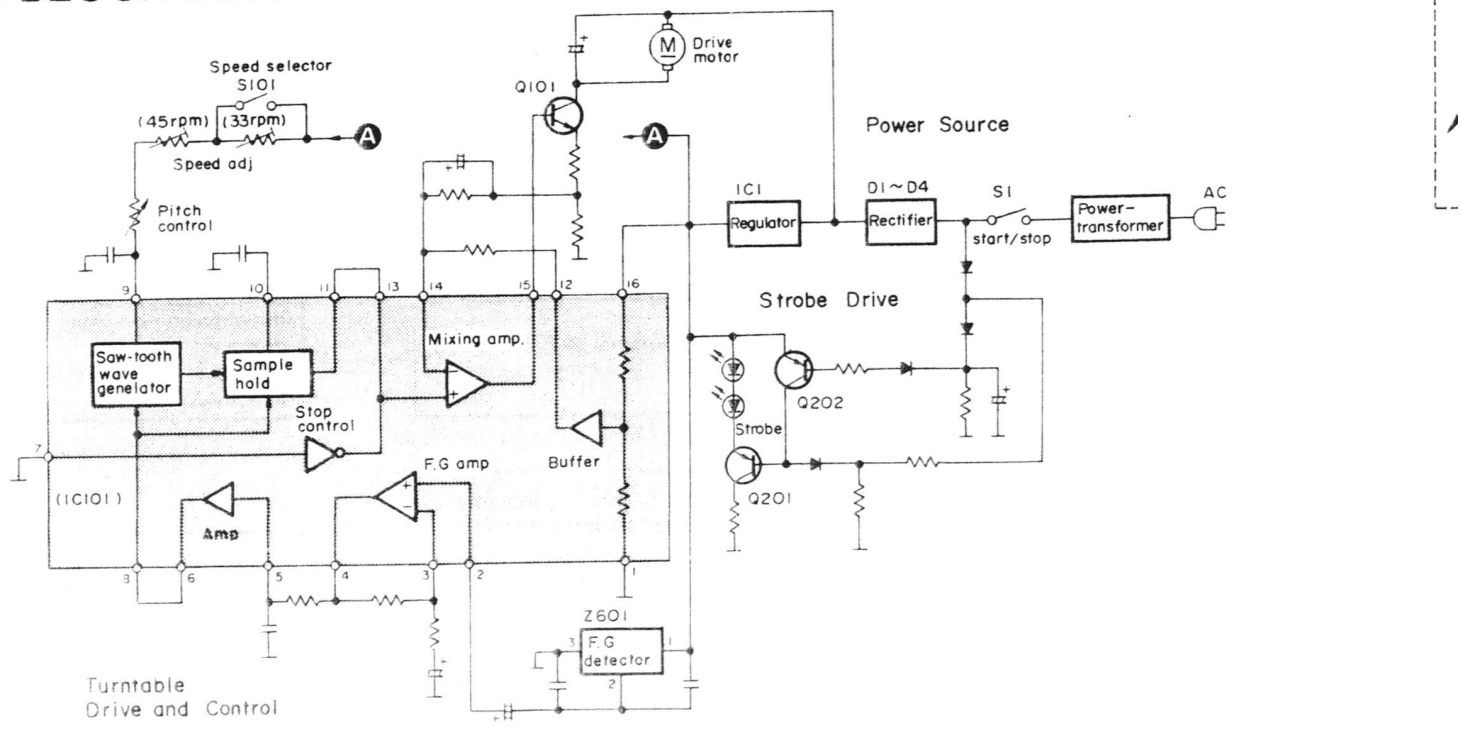

gy.)

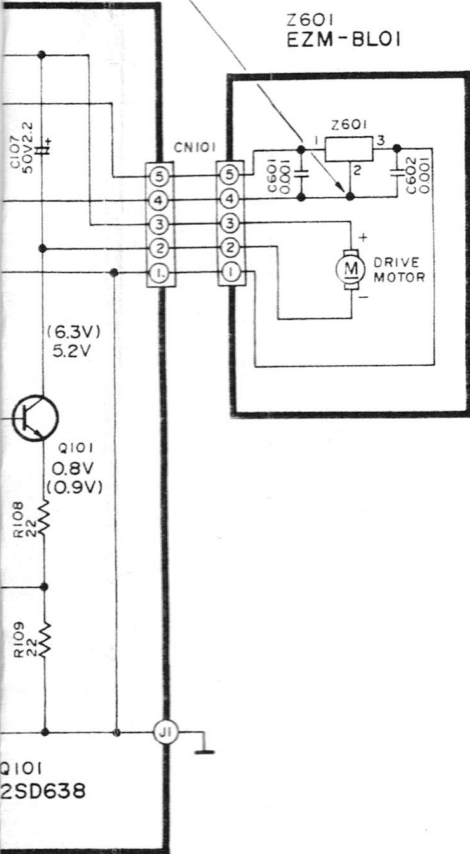
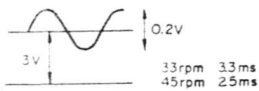

**Notes:**

1. S1: Power switch in "on" position.
2. S101: Speed selector switch in "33" position.
3. The values are of the reference voltage for the turntable rotation (33 rpm) of this unit, measured by a DC voltmeter (high impedance) on the basis of chassis. So, some error might be included depending on the internal impedance of the measuring instrument and the unit measured.  
\* ( ): voltage in 45 rpm.
4. Important safety notice:  
Components identified by a ⚠ mark have special characteristics important for safety. When replacing any of these components, use only manufacturer's specified parts.
5. VR101 is the 45 rpm speed adjustment variable resistor.
6. VR102 is the 33-1/3 rpm speed adjustment variable resistor.
7. This schematic diagram may be modified at any time with the development of new technology.

• Terminal guide of IC's, transistors and diodes

<p>SVIBA6301</p>	<p>AN78L06</p>	<p>SVDBR5505SA SVDBR5505SB</p>
<p>2SD638 2SB641</p>	<p>SVD1SR35200V</p>	<p>MA165</p>

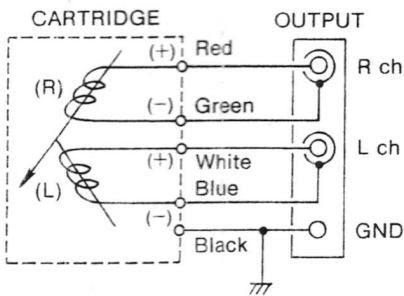

**Caution!**

- IC and LSI are sensitive to static electricity. Secondary trouble can be prevented by taking care during repair.
- Cover the parts boxes made of plastics with aluminum foil.
  - Ground the soldering iron.
  - Put a conductive mat on the work table.
  - Do not touch the legs of IC or LSI with the fingers directly.



No.	Operation	Description	Rotation angle of main gear	Fig. No.
6.	Record size detection	<ul style="list-style-type: none"> <li>★ Detection of 30 cm (12") record</li> <li>1. The record size detecting plate pushes the reset lever attached to the turntable platter.</li> <li>2. Only the 30 cm record detecting pin interlocked with the reset lever moves down.</li> <li>3. The 30 cm record detecting pin touches index plate (B), then index plates (A) and (B) rotate.</li> </ul>	170° ~ 238°	Fig. 4 ⑮
		<ul style="list-style-type: none"> <li>★ Detection of 17 cm (7") record</li> <li>1. The record size detecting plate pushes the reset lever attached to the turntable platter.</li> <li>2. Both 30 cm and 17 cm record detecting pins interlocked with the reset lever move down.</li> <li>3. The 30 cm and 17 cm record detecting pins touch index plate (B), then index plates (A) and (B) rotate.</li> </ul>	170° ~ 238°	Fig. 5 ⑯
		<ul style="list-style-type: none"> <li>★ In case of no record</li> <li>1. The record size detecting plate pushes the reset lever attached to the turntable platter.</li> <li>2. Both 30 cm and 17 cm record detecting pins interlocked with the reset lever remain up.</li> <li>3. The 30 cm and 17 cm record detecting pins do not touch index plate (B), so index plates (A) and (B) as well as index sub-plate remain stationary.</li> </ul>	170° ~ 238°	Fig. 4
7.	Positioning of index plate	<ul style="list-style-type: none"> <li>• When the main gear rotates, the drive plate starts moving in the direction of arrow ⑩.</li> <li>• Index plates (A), (B) and index sub-plate move back slightly as in the record size detection mode.</li> </ul>	255° ~ 278° 30'	Fig. 2 ⑰, ⑱
8.	Tonearm drop position	<ul style="list-style-type: none"> <li>• PU fixing plate moving pin turns the PU fixing plate, pushing it in the direction of arrow ⑪.</li> </ul>		Fig. 6
		<ul style="list-style-type: none"> <li>★ In case of 30 cm record</li> <li>The PU fixing plate rotates until drop positioning pin (A) contacts index plate (A).</li> </ul>	269° ~ 299°	Fig. 6
		<ul style="list-style-type: none"> <li>★ In case of 17 cm record</li> <li>The PU fixing plate rotates until drop positioning pin (A) contacts index plate (A).</li> <li>★ In case of no record</li> <li>The PU fixing plate does not rotate since drop positioning pin (B) is touching index plate (A).</li> </ul>	269° ~ 317°	Fig. 7  Fig. 8
9.	Power switch lock	<ul style="list-style-type: none"> <li>• The PU fixing plate rotates and the PU fixing plate pin pushes the switch control piece in the direction of arrow ⑫.</li> <li>• When the PU fixing plate pin moves to point ⑬, the switch control piece moves in the direction of arrow ⑭, and then the projection of the switch control piece is held by the mechanism board.</li> </ul>	269° ~ 299°	Fig. 1 ⑳ ~ ㉓
10.	Moving piece reversal	<ul style="list-style-type: none"> <li>• Actuating piece attached to the drive plate touches the mechanism board and is reversed, making the PU fixing plate moving pin free.</li> </ul>	310° ~ 326°	Fig. 3 ㉔
11.	Cueing down	<ul style="list-style-type: none"> <li>• Projection ⑮ of the drive plate is disengaged from the cueing cam, thereby shifting for cueing down.</li> </ul>	336° ~ 354° 40'	Fig. 2 ㉕
12.	Index cancel	<ul style="list-style-type: none"> <li>• Also, when the drive board moves, the index plate returns to the initial condition.</li> </ul>	340° ~ 360°	Fig. 2 ㉖
13.	Begin play	<ul style="list-style-type: none"> <li>• The main gear and small gear disengage; only the small gear continues to rotate (turntable rotation).</li> </ul>	360°	
14.	End play	<ul style="list-style-type: none"> <li>• The tonearm moves to the center of the turntable.</li> <li>• The PU fixing plate pushes the actuating rod.</li> <li>• Operation continues as in No. 1 Start.</li> </ul>		Fig. 1 ㉗ ~ ㉙
15.	Cueing up	<ul style="list-style-type: none"> <li>• (Same as No. 2 Cueing up)</li> </ul>	6° ~ 33°	
16.	Tonearm return	<ul style="list-style-type: none"> <li>• The drive board pushes the PU fixing plate moving pin; the tonearm returns to the arm rest.</li> </ul>	43° ~ 142°	
17.	Cueing down	<ul style="list-style-type: none"> <li>• (Same as No. 11 Cueing down)</li> </ul>	336° ~ 354° 40'	
18.	Power off	<ul style="list-style-type: none"> <li>• The fixed pin of the PU fixing plate contacts the switch control piece; the projection of the switch control piece breaks contact with the mechanism board. The switch lever rotates, causing the power switch contact to disengage.</li> </ul>	351° 30'	

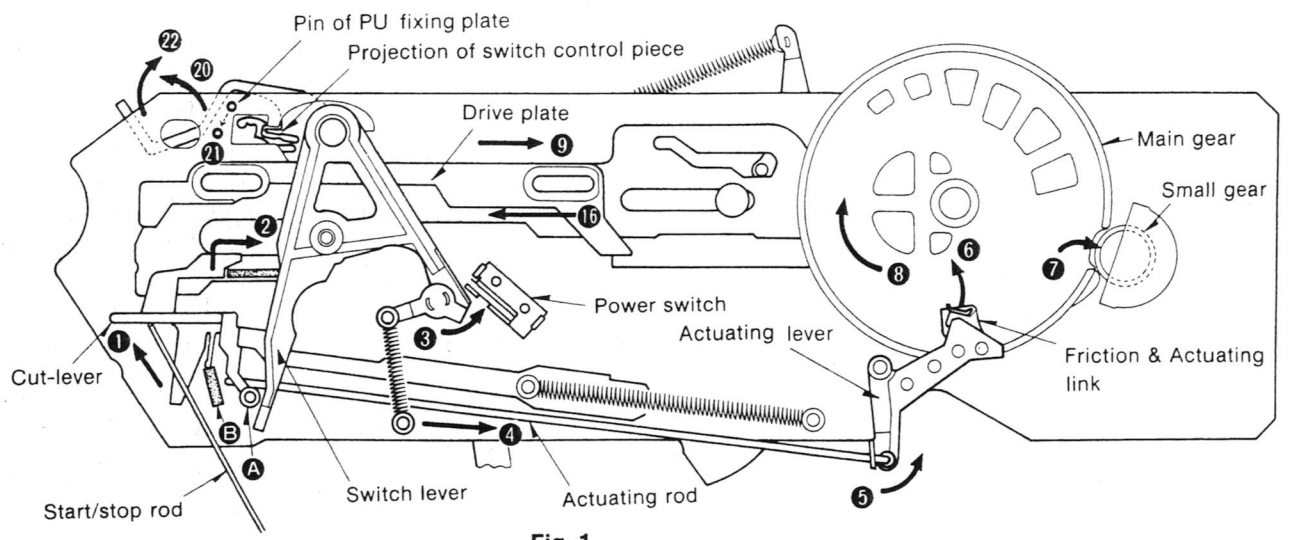

Fig. 1

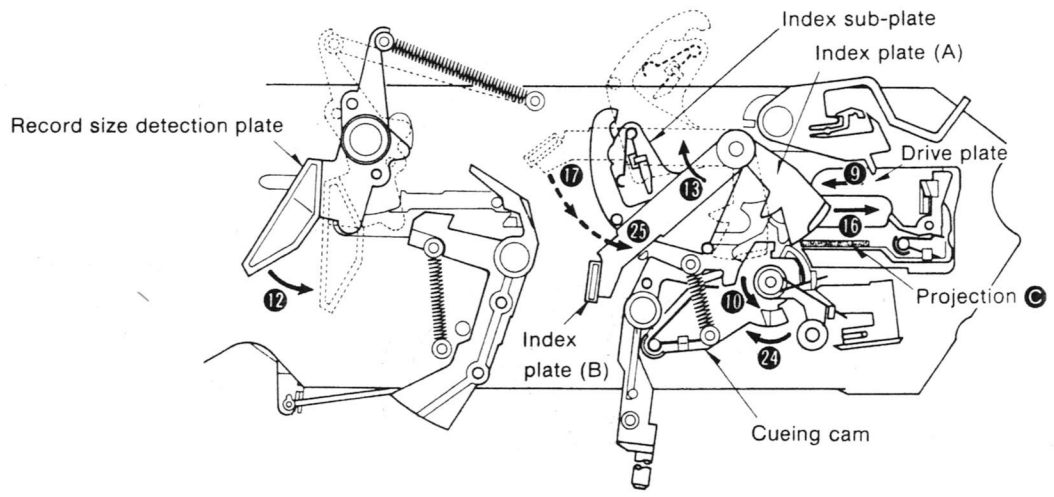

Fig. 2

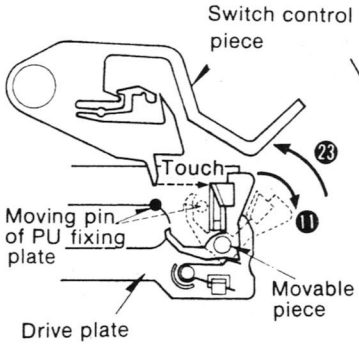

Fig. 3

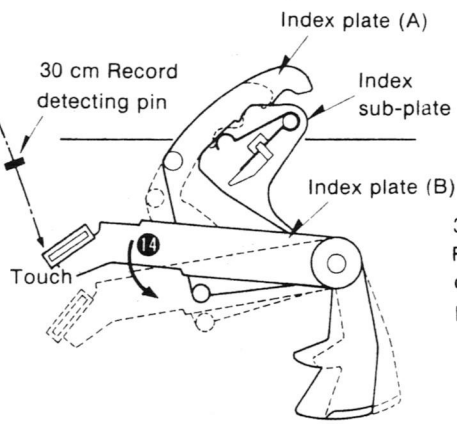

Fig. 4

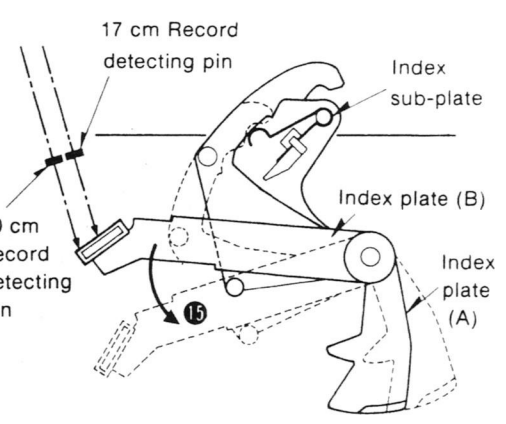

Fig. 5

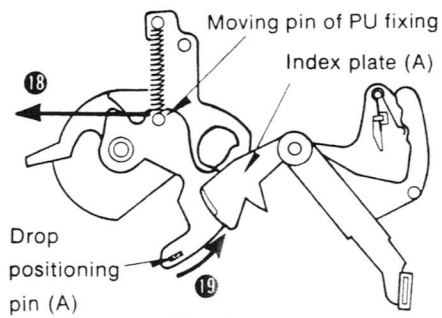

Fig. 6

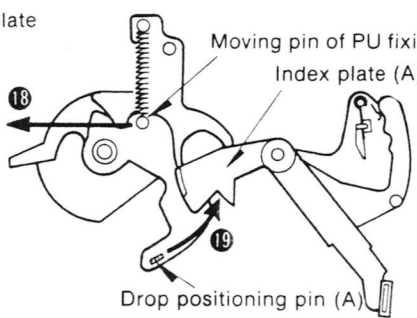

Fig. 7

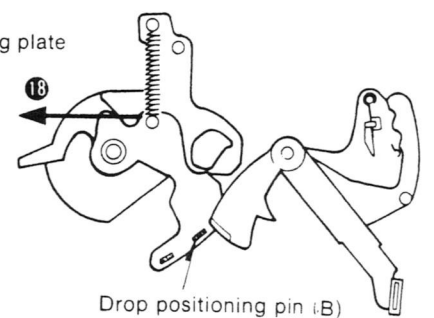
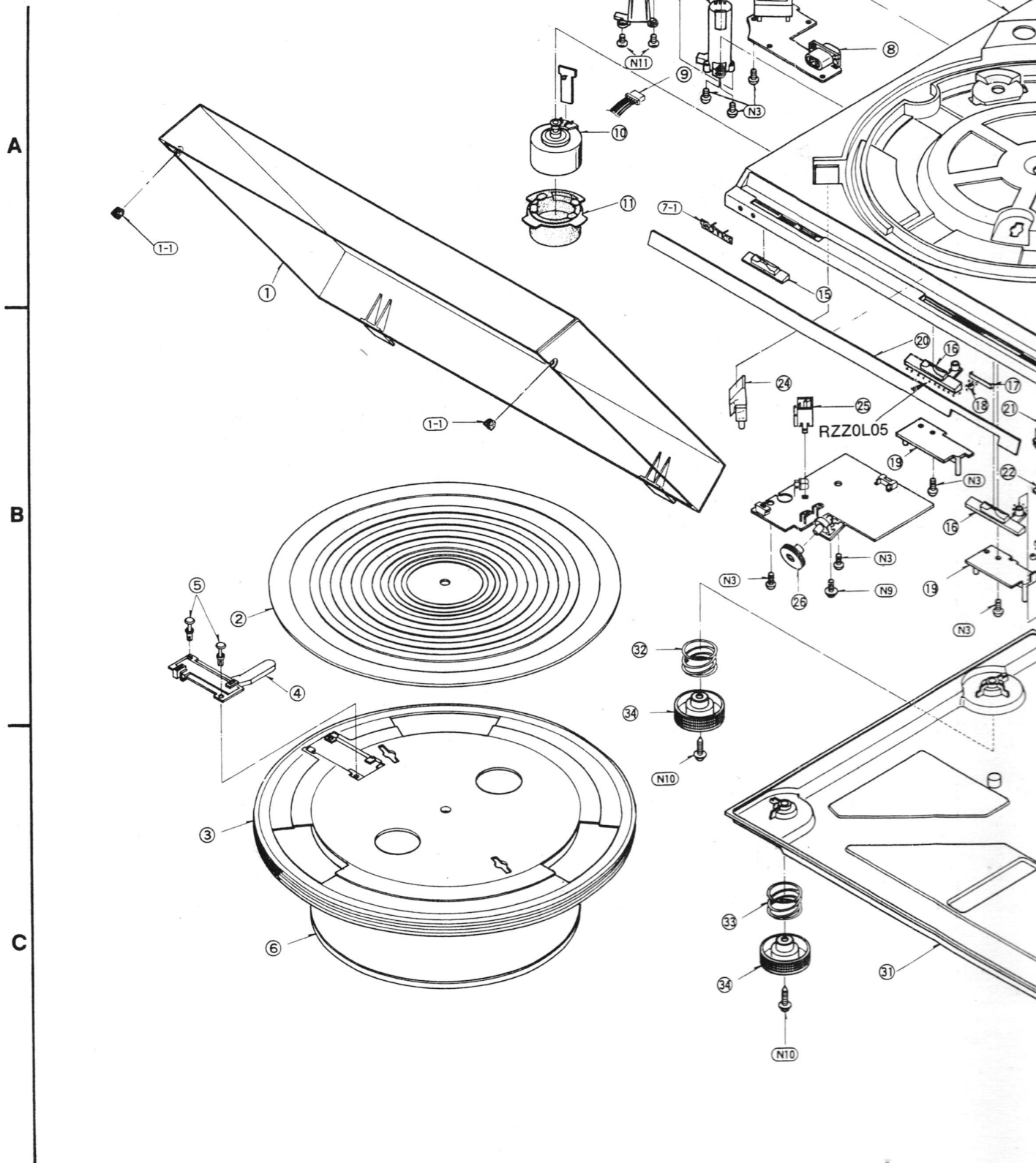

Fig. 8

# SL-BD35

## EXPLODED VIEW

• Cabinet and chassis parts



A	(1-1)	1	36 10 38 11 7-1 35 9 37	15	8	7
B	5	2	4	(1-1)	34 32	24 26 25 19 20 19 16 16 18 17
C	3	6	34 33	31		

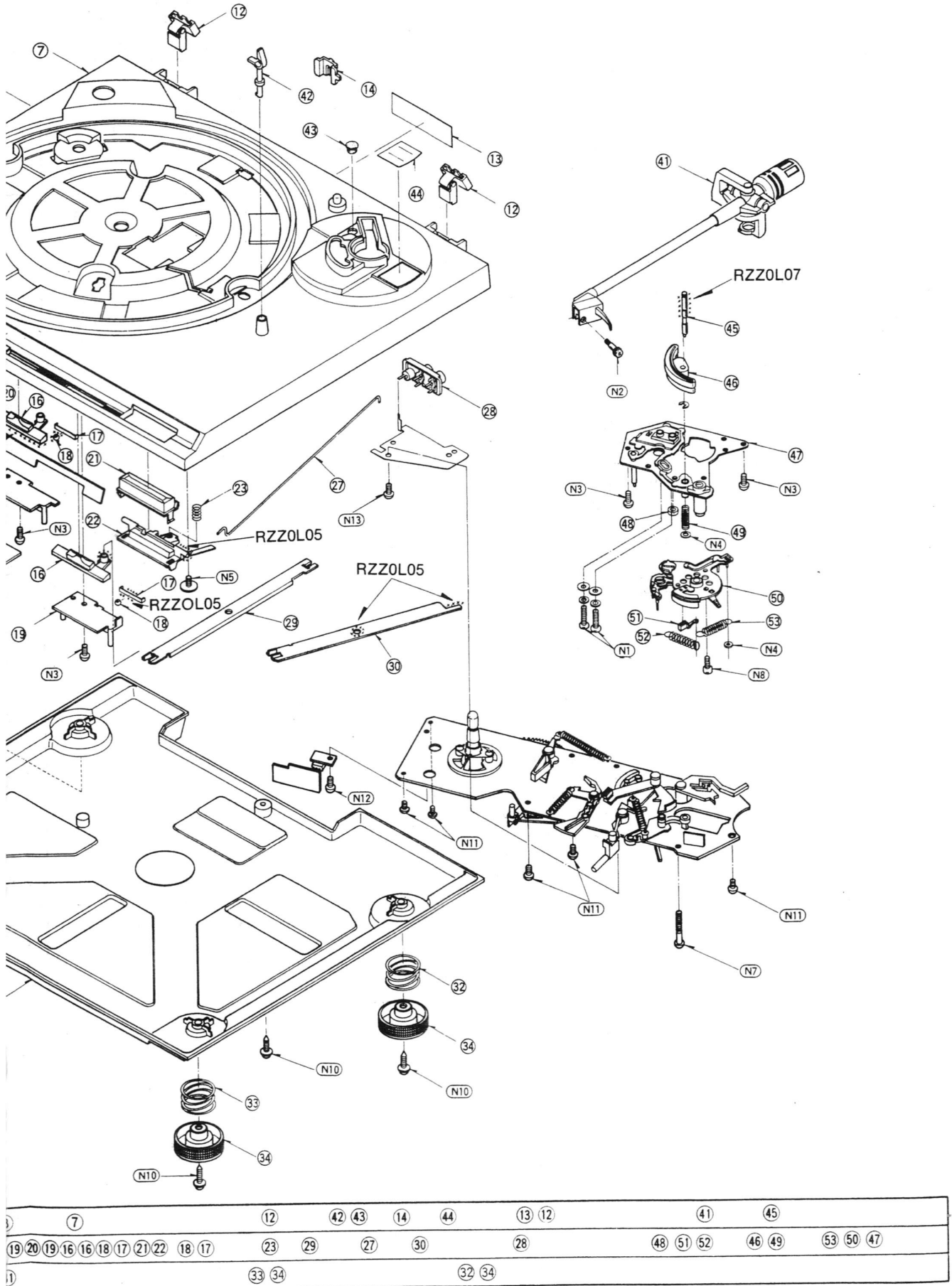



# REPLACEMENT PARTS LIST

- Notes:**
1. Part numbers are indicated on most mechanical parts. Please use this part number for parts orders.
  2. Important safety notice:  
Components identified by a  $\Delta$  mark have special characteristics important for safety.  
When replacing any of these components, use only

3. The "S" mark is service standard parts and may differ from production parts.
4. The parenthesized numbers in the columns of description stand for the quantity per set.

Ref. No.	Part. No.	Description
<b>INTEGRATED CIRCUITS</b>		
IC1	AN78L06	Regulator
IC101	SVIBA6301	Drive and Control
<b>TRANSISTORS</b>		
Q101	2SD638	Switching
Q201, 202	2SB641	Strobe Drive
<b>DIODES</b>		
D1,2,3,4	$\Delta$ SVD1SR35200V	Rectifier
D201,202	$\Delta$ SVD1SR35200V	Rectifier
D203	MA165	Switching
D204	SVDBR5505SA	Strobe
D205	SVDBR5505SB	Strobe
D206, 207	MA165	Switching
<b>SWITCHES</b>		
S1	$\Delta$ SFDSS5GLP	Power
S101	SFDHSW0834	Speed Selector
<b>VARIABLE RESISTORS</b>		
VR101,102	EVN61AA00B24	Speed Adjustment, 20 k $\Omega$ (B)
VR103	EVJE1AF20B14	Pitch Control, 10 k $\Omega$ (B)
<b>MAGNETIC RESISTOR ELEMENT</b>		
Z601	EZM-BL01	F.G. Detector
<b>POWER TRANSFORMER</b>		
T1	$\Delta$ SLT35KL5B	Power Source
<b>THERMISTER</b>		
R110	ERTD2FFK251S	250 $\Omega$
<b>LAMP</b>		
PL1	$\Delta$ SFDNB25M01	Disc Lamp
<b>RESISTORS</b>		
R101	ERDS2TJ152	Carbon, 1/4W, 1.5 k $\Omega$ , $\pm$ 5%
R102	ERDS2TJ183	Carbon, 1/4W, 18 k $\Omega$ , $\pm$ 5%
R103	ERDS2TJ682	Carbon, 1/4W, 6.8 k $\Omega$ , $\pm$ 5%
R104	ERDS2TJ223	Carbon, 1/4W, 22 k $\Omega$ , $\pm$ 5%
R105	ERDS2TJ272	Carbon, 1/4W, 2.7 k $\Omega$ , $\pm$ 5%
R106	ERDS2TJ152	Carbon, 1/4W, 1.5 k $\Omega$ , $\pm$ 5%
R107	ERDS2TJ824	Carbon, 1/4W, 820 k $\Omega$ , $\pm$ 5%
R108	ERDS2TJ220	Carbon, 1/4W, 22 $\Omega$ , $\pm$ 5%
R109	ERDS2TJ220	Carbon, 1/4W, 22 $\Omega$ , $\pm$ 5%
R201	ERDS2TJ472	Carbon, 1/4W, 4.7 k $\Omega$ , $\pm$ 5%
R202	ERDS2TJ332	Carbon, 1/4W, 3.3 k $\Omega$ , $\pm$ 5%

Ref. No.	Part. No.	Description
R203	ERDS2TJ390	Carbon, 1/4W, 39 $\Omega$ , $\pm$ 5%
R204	ERDS2TJ562	Carbon, 1/4W, 5.6 k $\Omega$ , $\pm$ 5%
R205	ERDS2TJ102	Carbon, 1/4W, 1 k $\Omega$ , $\pm$ 5%
Note: Resistors being used of disc lamp illuminator circuit are as follows.		
R102	$\Delta$ ERQ3CUJ122	Fuse Type Metal, 3W, 1.2 k $\Omega$ , $\pm$ 5%
R103	$\Delta$ ERQ3CUJ122	Fuse Type Metal, 3W, 1.2 k $\Omega$ , $\pm$ 5%
<b>CAPACITORS</b>		
C1	$\Delta$ ECQF1A472MD	Polyester, 100V, 0.0047 $\mu$ F, $\pm$ 20%
C2, 3	$\Delta$ ECQG1223KZ	Polyester, 100V, 0.022 $\mu$ F, $\pm$ 10%
C4	ECEA1CU331	Electrolytic, 16V, 330 $\mu$ F
C5	ECEA0JU330	Electrolytic, 6.3V, 33 $\mu$ F
C101, 102	ECEA1HU010	Electrolytic, 50V, 1 $\mu$ F
C103	ECQM1H473KV	Polyester, 50V, 0.047 $\mu$ F, $\pm$ 10%
C104	ECQP1104JZ	Polypropylene, 100V, 0.1 $\mu$ F, $\pm$ 5%
C105	ECQM1H103KV	Polyester, 50V, 0.01 $\mu$ F, $\pm$ 10%
C106	ECEA1EU3R3	Electrolytic, 25V, 3.3 $\mu$ F
C107	ECEA1HU2R2	Electrolytic, 50V, 2.2 $\mu$ F
C201	ECEA1HU010	Electrolytic, 50V, 1 $\mu$ F
C601, 602	ECUX1H102MBM	Chip Ceramic, 50V, 0.001 $\mu$ F, $\pm$ 20%
<b>CABINET AND CHASSIS PARTS</b>		
1	SFADZ15R01E	Dust Cover (with Cushion Rubber) (1)
1-1	SFGZD04N01	Rubber Cushion, Dust Cover (2)
2	SFTGBD3N01	Turntable Mat (1)
3	SFTEBD3N01	Turntable Platter (1)
4	SFUMB33N20A	Base, Disc Size Sensor (1)
5	SFUZD33-01E	Latch, Disc Size Sensor Base (2)
6	SFGBZ15R01	Belt (1)
7	SFACBD8M01E	Cabinet (1)
7-1	SFKBBD2N01	Badge (1)
8	$\Delta$ SFDJHSC0509	AC Socket (1)
9	SFDJBD2N02E	Connector Ass'y (5P) (1)
10	SFMHBD2N01E	Motor (1)
11	SFUMB2N08	Cushion Rubber, Motor (1)
12	SFATZ15R01A	Hinge (2)
13	SFNNBD8M01	Name Plate (1)
14	SFUMB3N03	Cover (1)
15	SFKTBD2N03	Knob, Speed Selector (1)
16	SFKTBD2N02	Knob, Cueing and Repeat (2)
17	SFQPZ15R02	Spring Plate (2)
18	SFYB-5-32	Ball (2)

Ref. No.	Part. No.	Description
19	SFUMB3N02	Bracket, Cueing and Repeat Knob (2)
20	SFKKBD8M01	Ornament (1)
21	SFKTBD2N01	Knob, Stop (1)
22	SFUMB3N01	Base, Stop Knob (1)
23	SFQHZ15R01	Spring, Stop Knob (1)
24	SFUMB2N07	Strobe (1)
25	SFUMB2N06	Holder, LED (1)
26	SFKTBD2N04	Knob, Speed Adjuster (1)
27	SFUZB63M01	Rod, Start, Stop Knob (1)
28	SFDJBD2N01	Jack, Output (1)
29	SFUMB2N03	Lever, Cueing (1)
30	SFUPB63M01	Lever, Repeat (1)
31	SFAJBD2N01	Bottom Cover (1)
32	SFQCQD3N01	Spring, Insulator (Rear) (2)
33	SFQCQD2N01	Spring, Insulator (Front) (2)
34	SFGABD2N01	Insulator (4)
35	SFUMB25M03	Case (1)
36	SFUMB25M02	Holder (1)
37	SFUMB25M01	Prism (1)
38	SFGZB25M01	Spacer (1)
<b>TONELARM PARTS</b>		
41	SFPAMBD201A	Tonearm (1)
42	SFKUMA1N01E	Tonearm Rest (1)
43	SFGK170-01	Cap (1)
44	SFKKBD2N02	Plate, Cancellor (1)
45	SFXJBD2N51	Shaft, Arm Lift (1)
46	SFUMB2N51	Arm Lift (1)
47	SFUPBD3N51E	Arm Base (1)
49	SFQAZ15R53	Spring (1)
50	SFUPB63M52E	Plate, Pick-up Mounting (1)
51	SFUMZ15R57	Spring Pin (1)
52	SFQHB63M57	Spring (1)
53	SFQHB63M56	Spring (1)
<b>AUTOMATIC MECHANISM PARTS</b>		
60	SFUKB63M52E	Plate Ass'y, Automatic Mechanism (1)
61	SFUMB63M65	Guide, Switch Lever (1)
62	SFUMB63M62	Sub Plate, Index (1)
63	SFQPB63M53	Spring, Index (1)
64	SFUMB63M63	Plate (A), Index (1)
65	SFUMB63M64E	Plate (B) Ass'y, Index (1)
66	SFQSB63M52	Spring, Cueing Cam (1)
67	SFUMB63M61	Lever, Brake (1)
67-1	SFUZB63M52	Felt, Brake (1)
68	SFQHB63M55	Spring, Cueing Cam (1)
69	SFQPB63M52	Spring, Cueing Cam (1)
70	SFQPB63M54	Spring, Cueing Cam (1)
71	SFUMB63M60	Cam, Cueing (1)
72	SFUMB63M59	Lever, Cueing (1)
73	SFQHB63M54	Spring, Repeat Plate (1)
74	SFUMB63M58	Lever, Repeat (1)
75	SFQHB63M53	Spring, Record Size Detector (1)
76	SFUMB63M57E	Record Size Detector Ass'y (1)

Ref. No.	Part. No.	Description
77	SFTUB63M51A	Turntable Shaft Ass'y (1)
78	SFUGB63M51E	Main Gear Ass'y (1)
79	SFUMB63M54	Motive Plate (1)
80	SFQSB63M51	Rod (1)
81	SFQHB63M51	Spring, Cancel Lever Ass'y (1)
82	SFUMB63M53E	Lever Ass'y, Cancel (1)
82-1	SFQHB63M52	Spring, Switch Lever Ass'y (1)
83	SFUMB63M55E	Lever Ass'y, Switch (1)
84	SFUBB63M51E	Plate Ass'y Drive (1)
84-1	SFQPB63M51	Spring, Drive Plate Ass'y (1)
84-2	SFUMB63M51	Lever (1)
84-3	SFUMB63M52	Repeat Plate (1)
85	SFUMZ15R56	Pin (7)

Ref. No.	Part. No.	Description
<b>SCREWS AND WASHERS</b>		
N1	XYN3+F12	Screw, $\odot 3 \times 12$ (2)
N2	SFPEV0Q601	Screw, Cartridge (1)
N3	XTV3+8G	Screw, $\odot 3 \times 8$ (7)
N4	SFXWZ15R51	Washer (1)
N5	SFXGQ06N01	Screw (1)
N6	XUC3FY	Washer, $\phi 3$ (1)
N7	XTV3+30J	Screw, $\odot 3 \times 30$ (1)
N8	SFXGQ34N02	Screw (1)
N9	XTW3+10Q	Screw, $\odot 3 \times 10$ (1)
N10	XTW3+14QFYR	Screw, $\odot 3 \times 14$ (5)
N11	XTV3+10G	Screw, $\odot 3 \times 10$ (5)
N12	XYE3+EJ8	Screw, $\odot 3 \times 8$ (1)
N13	XTV3+20J	Screw, $\odot 3 \times 20$ (1)
N14	XTV3+14J	Screw, $\odot 3 \times 14$ (2)
N15	SFXWZ15R51	Washer (11)
N16	SFXWB63M52	Washer (2)
N17	SFXWB63M51	Washer (2)
N18	SFUMZ15R61	Washer (1)
N19	SFXWQ34N22	Washer (1)

Ref. No.	Part. No.	Description
<b>ACCESSORIES</b>		
A1	SFNUBD8M01	Instruction Book (1)
A2	SFDHBD2N01	Output Cord (1)
A3	SFDLJ02N11E	Ground Wire (1)
A4	SFWE212-01	45 Adaptor (1)
A5	$\triangle$ SFDAC05M02	AC Cord (1)
<b>PACKING PARTS</b>		
P1	SFHBPB8M01	Carton Box (1)
P2	SFHBD3N01	Pad, Left (1)
P3	SFHBD3N02	Pad, Right (1)
P4	SFHKB63M01	Clamper, Turntable (2)
P5	SFHZB63M01	Clamper, Tonearm (1)
P6	SFHZZ15R02	Clamper, Cord (1)
P7	SFYF75A41	Polyethylene Sheet (1)
P8	SFYH60X60	Polyethylene Bag, Unit (1)
P9	SFYH52X50	Polyethylene Bag, Dust Cover (1)
P10	SFYH17X16	Polyethylene Bag, Cord (1)
P11	SFHZBD2N01	Pad, Weight (1)