

Table of Contents

| | |
|-----------------------------|-----|
| WARRANTY..... | P1 |
| Statement of Coverage | p1 |
| Purchaser's Record | p2 |
| After Unpacking | p3 |
| INTRODUCTION..... | P4 |
| Equalization...why? | p4 |
| Front Panel Controls | p9 |
| Rear Panel Connections | p10 |
| HOOKUP INSTRUCTIONS..... | P11 |
| Tape Deck Connections | p11 |
| Normal System Connections | p12 |
| Special Applications | p12 |
| MODEL 210 FLOW-GRAPHS..... | P14 |
| EQUALIZATION CONTROLS..... | P18 |
| Range of Adjustment | p18 |
| Corrective Equalization | p20 |
| Creative Equalization | p21 |
| Musical Instrument Spectrum | p22 |
| Helpful Hints | p22 |
| UNITY GAIN ADJUSTMENTS..... | P23 |
| Method for Playback | p24 |
| Method for Recording | p24 |
| Headroom Considerations | p24 |
| CLEANING..... | P25 |
| REPAIR FACILITIES..... | P25 |
| SHIPPING..... | P26 |
| RETURN AUTHORIZATION..... | P25 |
| SPECIFICATIONS..... | P27 |

Spectro Acoustics

FIVE YEAR WARRANTY PROGRAM

SPECTRO ACOUSTICS, INC. warrants that all new Model 210 Graphic Equalizers shall be free from defects in workmanship and materials under normal and proper use and service for a period of five years from date of delivery to original using purchaser, and agrees to repair or replace all parts thereof showing such defects; subject to the following provisions.

Inspection shall disclose to SPECTRO ACOUSTICS, INC. satisfaction that the defects are as above specified and that the equipment has not been altered or repaired by other than factory approved procedures, subjected to negligence, misuse or accident, or damaged by excessive current or otherwise, or had its serial number or any part thereof altered, defaced or removed, or has been used contrary to SPECTRO ACOUSTICS, INC. Handbook of Instructions.

This warranty is expressly in lieu of all other warranties, expressed or implied, and all other obligations or liabilities on the part of SPECTRO ACOUSTICS, INC. No person, including any dealer, agent or representative of SPECTRO ACOUSTICS, INC. is authorized to assume for SPECTRO ACOUSTICS, INC. any liability on its behalf or in its name except to refer purchasers to this warranty. In no event shall SPECTRO ACOUSTICS, INC. be liable for claims, demands or damages of any nature, however denominated; SPECTRO ACOUSTICS, INC. sole warranty liability shall be to repair defective items or to supply replacement parts in accordance with the terms of this warranty.

This warranty is valid not only for the original purchaser, but any and all subsequent owners for five years from original purchase.

SPECTRO ACOUSTICS, INC. reserves the right to make changes at any time prior to delivery to incorporate therein refinements deemed appropriate, but without incurring any liability to up-date any equipment delivered previously, or to supply new equipment in accordance with earlier specifications.

PURCHASER'S RECORD

Registration For SPECTRO ACOUSTICS, INC. Five Year Warranty

Model: SPECTRO ACOUSTICS, INC. Model 210 Graphic Equalizer

Serial Number: _____

Purchaser's Name: _____

Address: _____

Price Paid: _____ Date Purchased: _____

Date Warranty Card Mailed: _____

The above information becomes your permanent record of a valuable purchase as well as a valuable insurance record; and must also be referred to should you have any correspondence with SPECTRO ACOUSTICS, INC. You should promptly fill in the above information and the Warranty Registration Reply Card. Mail the Warranty Registration Reply Card to SPECTRO ACOUSTICS, INC.

Contents of Carton:

SPECTRO ACOUSTICS, INC. Model 210 Graphic Equalizer
Handbook of instructions
Warranty Registration Reply Card

(Notices and other enclosures may also be included.)

Before leaving our factory, your SPECTRO ACOUSTICS, INC. Model 210 was tested and certified to be in perfect operating condition. This manual has been prepared to help you operate your Model 210 as well as keep it in perfect operating condition. Your SPECTRO ACOUSTICS, INC. Model 210, with care befitting all fine instruments, is capable of providing a lifetime of musical enjoyment.

Should there be any questions, please contact the SPECTRO ACOUSTICS, INC. National Service Manager at SPECTRO ACOUSTICS, INC., P.O. Box 2190, Pasco, Washington 99302 (U.S.A.)

After Unpacking

It will be advantageous to save all of the packing materials, cartons, fillers, cushioning, etc. The packing materials have been designed especially for the Model 210, and will prove valuable in preventing damage, should it ever become necessary to transport or ship the Graphic Equalizer.

Please inspect the Model 210 carefully for any signs of damage incurred in transit. It has undergone a very strict quality control inspection system and test, prior to packing; thus it left the factory in perfect operating condition. If damage is discovered, notify the transportation company without delay. Only the consignee may institute a claim with the carrier for damage incurred during shipment; however, SPECTRO ACOUSTICS, INC. will cooperate fully in such an event. Save the carton as evidence of damage for the carrier's inspection.

INTRODUCTION

EQUALIZATION...WHY?

It is generally understood that the main goal in music recording and subsequent reproduction is to maintain perfect "fidelity" throughout the process. In other words, the reproduced performance, as heard by the listener, should be as near identical to the original performance, including any "effects" added during recording (purposely), as is possible. Even the commonly used term "High fidelity" implies this goal.

In practice, however, perfect fidelity cannot be achieved. This is due to the fact that all acoustical, electro-mechanical, and electronic systems add some degree of change to any signal which passes through them. These changes or deviations from perfect fidelity can be categorized to form four basic groups, listed below with examples of their typical sources:

| <u>GROUP</u> | <u>EXAMPLES</u> and their typical <u>SOURCES</u> |
|-----------------------|--|
| A) TIME DOMAIN | 1) Unwanted reverberation or echo.....acoustical 2) Unwanted ambience.....acoustical 3) Phase distortion.....electronic and acoustical 4) Ringing or unwanted sustain.....acoustical |
| B) DISTORTION | 1) Harmonic generation (THD)..transducers and electronics 2) Intermodulation distortion (IM).....electronics 3) Transient IM (TIM).....negative feedback amplifiers 4) Dynamic distortion....expanders, compressors, limiters |
| C) NOISE AND HUM | 1) Thermal noise (hiss).....all resistors 2) Excess noise (hiss)..all tubes and solid state devices 3) 1/f noise (flicker)..all tubes and solid state devices 4) Surface noise (hiss, ticks, pops)...phonograph records 5) Tape noise (hiss).....all magnetic tape systems 6) Microphonics (physical vibration pickup)..vacuum tubes 7) Hum (60Hz & 120 Hz).....poor grounding and shielding magnetic coupling between transformers and wound coils |
| D) FREQUENCY RESPONSE | 1) Low frequency dips..microphones, cartridges, speakers 2) Mid-low frequency peaks.....speaker resonances 3) Mid-high frequency peaks.....cartridge resonances 4) High frequency dips.....tapes, cartridges, speakers 5) Full spectrum narrow-band deviations..... microphones, cartridges, speakers, and room acoustics! |

The deviations from absolute fidelity listed under groups A, B and C are hard facts of life that, once added to the program material during recording, cannot be removed or reversed, with the exception of B4, which can be undone, at least to some extent, through the use of dynamic range expansion techniques.

Although noise cannot actually be removed during playback, without also removing substantial amounts of program material (since true noise correlation is impossible due to the random nature of noise itself, regardless of certain claims of "auto-correlation" by one prominent manufacturer) the ear can be fooled into believing that noise has been reduced through the use of dynamic noise suppressors available on today's audio market.

During the total recording process, from the acoustical studio design to the finished phonograph record or magnetic tape on your dealer's shelf, vast effort is expended (at least by most recording companies) in assuring that the deviations of groups A, B and C are kept to a minimum or as close to zero as possible. No matter what type of playback system the recording is intended for, it is universally agreed that deviations in TIME DOMAIN, DISTORTION, and NOISE should be restricted to an absolute minimum, always. Modern studio design and recording technique is aimed at this universal goal, as well as the ever-present struggle by electronic equipment designers to reduce distortion and noise to so near zero as to defy detection.

Group D, of frequency response deviations, poses quite a different problem. The ideal overall frequency response of the recording process is not always (in fact seldom) flat response, or as near zero deviation as possible. We are not talking about the forms of pre-equalization associated with phonograph discs or magnetic tape, which are deviations purposely introduced in order to make recording on tape or disc possible, for these are cancelled upon playback by appropriate opposite equalization (RIAA & NAB) found in all quality playback electronics. No, we are referring to deviations introduced either accidentally, or as a function of a particular recording engineer's ear, or purposely in an attempt to pre-equalize the recording so that it will sound right on the "average stereo system". Recording companies are well aware that the typical playback system has a response which itself deviates, often greatly, from our goal of flat response, or zero deviation. It is for this reason that most commercial recordings are pre-equalized in an attempt to correct for later deviations encountered in playback! Often, in the case of recordings aimed at AM radio audiences, the final mixdown is monitored through a single 6x9" car radio speaker, and equalized to sound correct when played back accordingly!

Admittedly, recordings aimed at the "hi-fi" listener are not usually bastardized to this extent, but vast differences from one recording to the next are prevalent in terms of this pre-equalization, whether intentional, accidental, or simply because the studio monitor environment (including the recording engineer's ears!) is different in nearly every case from the environment of playback (which includes your electronics, your speakers, your listening room, and most important, your ears!) If recording engineers could somehow know the exact response of each individual's total playback system, they could then pre-equalize each disc or tape on a custom basis. Of course distributing the right recording to the right buyer would become a totally impractical and very expensive situation. Fortunately, if you are reading this owner's manual, you have already acquired all the equipment necessary to completely solve this problem. Your model 210 Graphic Equalizer has been designed to allow you to decide how your playback system will be equalized, and to give you full control over the frequency response of your recordings, while adding only totally inaudible deviations in terms of TIME DOMAIN, DISTORTION, and NOISE.

Nearly all playback systems include some means of altering the frequency balance of program material upon playback. The most common types are some form of "tone controls", either a single control labeled "TONE" or two separate knobs labeled "BASS" and "TREBLE". These controls, although somewhat useful in terms of equalization in a very general sense, have strictly limited value in terms of actually equalizing for flat response. This is due to their inherent lack of "frequency selectivity". A thorough understanding of this term can be had by some study of the graphic example shown on the next page.

We shall assume, momentarily, that we have in our possession a recording which, by some fluke of nature, has been equalized for flat response when played on the perfect stereo system, with flat response. Unfortunately, the rest of our system; the speakers and the listening room exist in the plane of reality, and have frequency responses which are something less than totally perfect and flat. Our electronics, as in the real world, are high quality Spectro Acoustics units, and have no measurable deviation from perfection in the audible frequency spectrum...well, at least their imperfections are inconsequential.

Measuring the frequency response of our speakers, assuming they are identical, gives us the plot of Figure I.

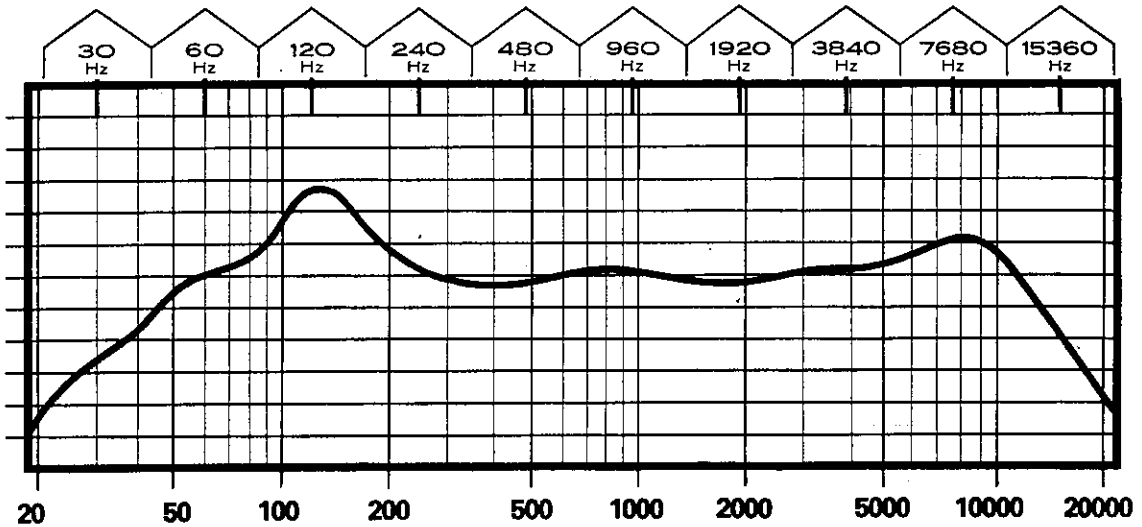

FIGURE I TYPICAL SPEAKER RESPONSE

Using the same technique for measurement, a plot of the response of our listening room appears in Figure II.

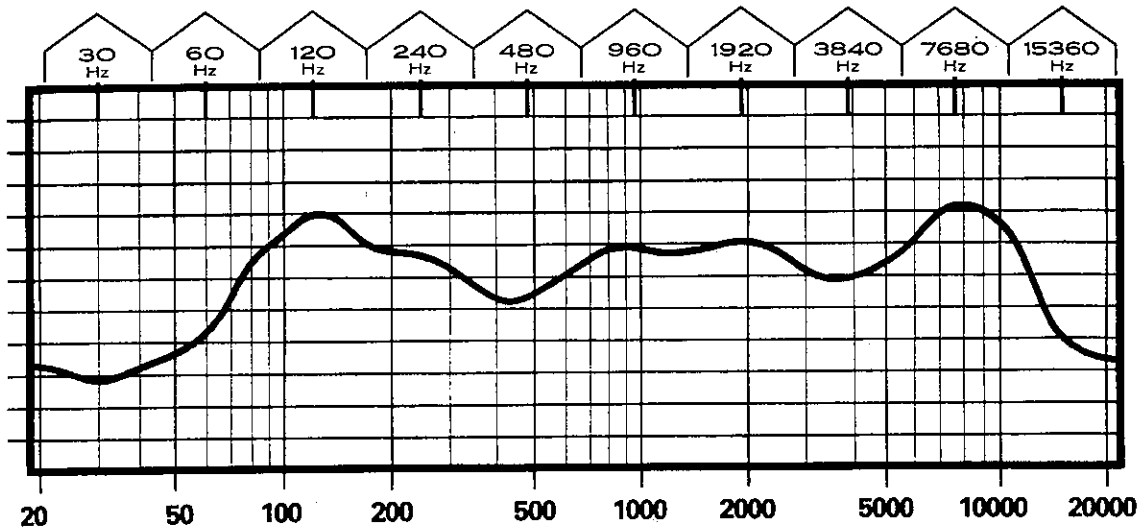

FIGURE II TYPICAL ROOM RESPONSE

Combining graphs by simple addition at each frequency, the total response of our speaker/room combination, and therefore our entire playback system (assuming as we are that no deviations are contributed by the electronics or phono cartridge) is shown in Figure III.

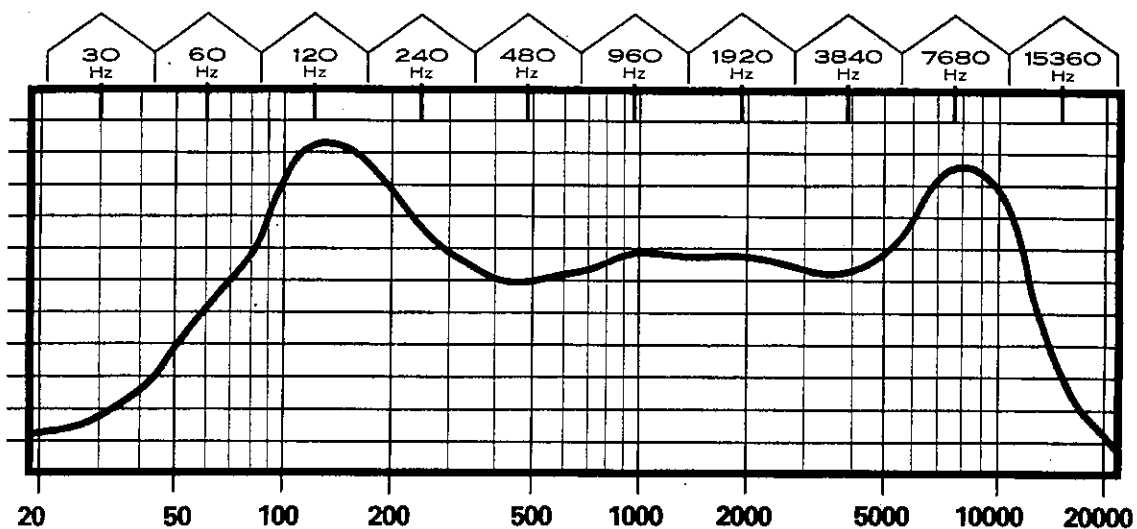

FIGURE III TOTAL SYSTEM RESPONSE

As can be seen, in order to hear our perfect recording as it was intended, some corrections must be made in the total playback response. This correction procedure is called EQUALIZATION. Notice that, due to resonance peaks in the system, frequencies near 120 Hz and 7680 Hz will require some attenuation, or "cut". On the other hand, due to speaker inefficiencies and room absorption, the lowest frequencies, near 30 & 60 Hz and the upper frequencies, near 15360 Hz will require amplification, or "boost". The middle frequencies are reasonably flat. We decide to try to equalize this response using standard bass and treble tone controls, which have a range of adjustment shown by the plots of Figure IV. (Each plot is given for a "3dB" step of the control, and the turnover frequencies in this case are standard: Bass= 250 Hz, Treble= 2500 Hz)

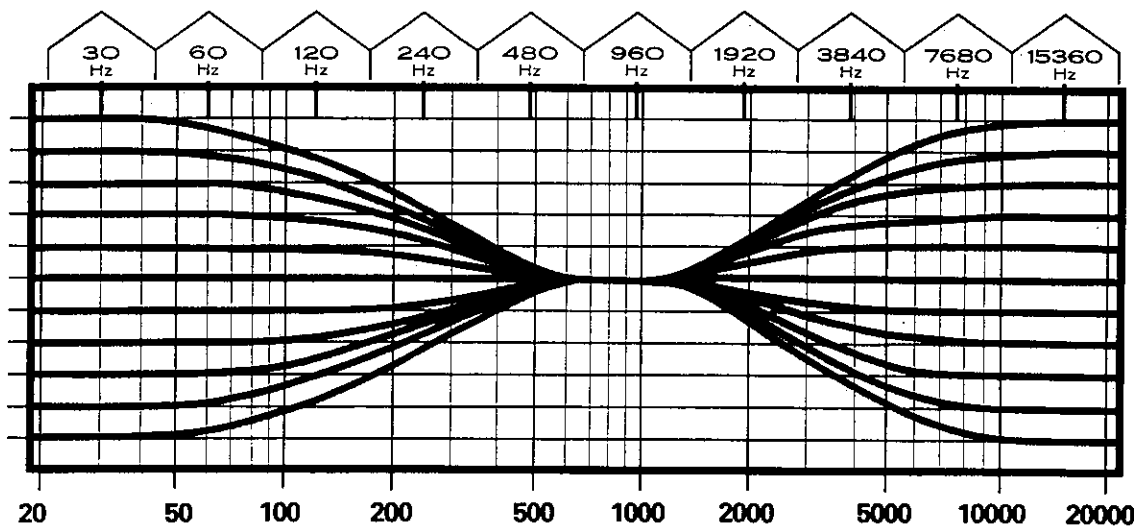

FIGURE IV TYPICAL TONE CONTROLS

It will become apparent that these typical bass and treble controls simply cannot flatten the system response. In a case such as this hypothetical one (which is actually fairly typical), if we try to boost the low frequencies the required amount, the 120 Hz speaker resonance is further boosted and made more annoying! Vice-versa, if we decide to apply enough bass cut to correct the 120 Hz problem, we almost completely wipe out the response at 60 Hz, and the 30 Hz plot goes off scale! The same sort of problems will occur when trying to flatten the high frequency response. The answer, of course, is to utilize a "tone control" or equalizer that can select different amounts of boost or cut even in adjacent or nearby frequency bands. This is "frequency selectivity".

Of course, since we now desire several separate controls, one for each musical octave in the case of the Model 210, some means of keeping track of all these multiple settings is necessary. It is for this reason that all graphic equalizers employ slide type controls, so that the total equalizer setting can always be observed, in graph form, simply with a glance. Hence the term "graphic equalizer".

Using the Spectro Acoustics Model 210 Graphic Equalizer, flattening this system's frequency response is a simple matter of adjusting the individual octave controls to form a mirror image or opposite graph as that of the system itself! The 210 will then boost the necessary frequencies just the right amount and cut the peaks, even in adjacent octaves. Of course, if the system's frequency response was so ragged that adjacent musical notes within an octave needed opposite adjustment, the 210 could not flatten the response either. One might think, then that an equalizer with a control for each note would be the ultimate, but we believe that after even one day of trying to adjust those 80 sliders, 160 for stereo, the poor user would die of frustration, not to mention the cost, reliability, and noise performance factors. In order to package a unit like that, the sliders would have to be so small that fingers would appear as giant cranes attempting to lift a penny from the ground. These facts, along with the fact that octave band filters produce far less phase shift and are more or less standardized among competing manufacturers, have prompted the decision of Spectro Acoustics engineering and marketing team to lead the way in perfecting the ten band octave equalizer.

Incidentally, the Model 210 utilizes separate controls per channel, 20 in all rather than ganged stereo channels, which would be easier to adjust, for two main reasons. The first and most important reason is that given two identical speaker systems in a room full of carpets and furniture, the left channel's response would seldom be the same as the right channel's. This is due to the differing levels of sound absorption and reflection in different parts of the listening room. The second reason applies to applications of the 210 other than stereo playback equalization. The fact that each channel's controls are separate lends the 210 to use as a pair of separate channel equalizers, totally independent, for use in live or studio recording.

By now, you should be familiar with the basic function of your Model 210, the reasons behind its design, and something about equalizing in general. Now let's get familiar with the unit itself.

Front Panel Controls

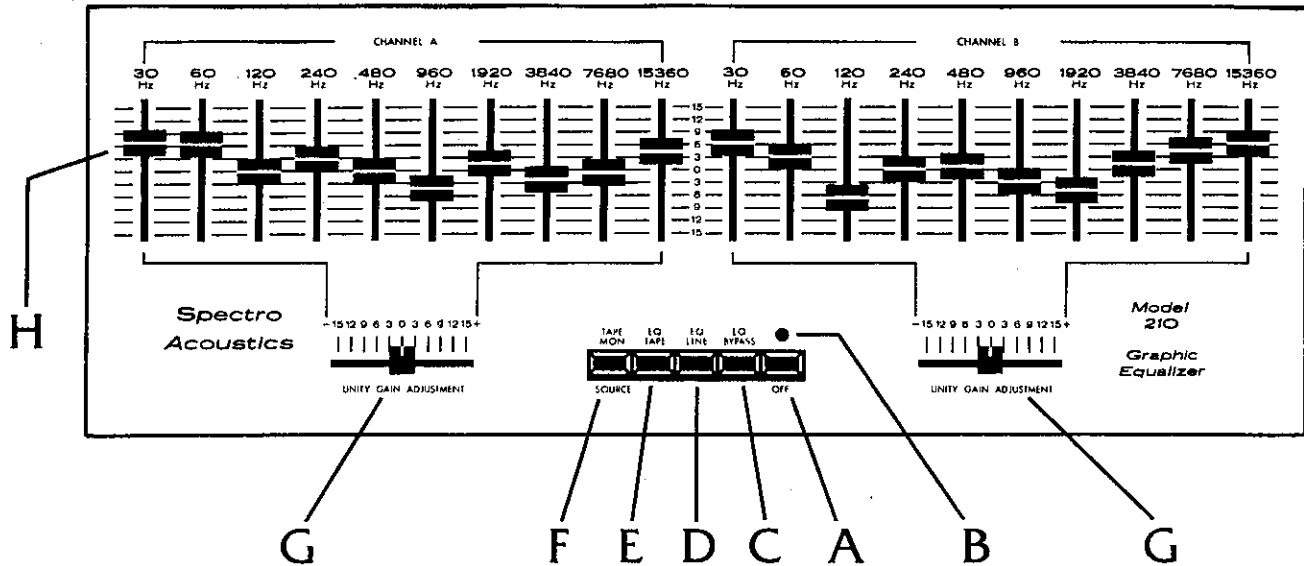

FIGURE V FRONT PANEL

| <u>CONTROL NAME</u> | <u>CONTROL FUNCTION</u> |
|------------------------------|---|
| A) Power on/off button | Turns on power when pushed in, only necessary when in EQ LINE or EQ TAPE mode. |
| B) Pilot L.E.D. | Indicates, by glowing red, that AC line power is on. Also verifies that internal power supply is functioning. |
| C) EQ BYPASS button | Bypasses all equalizer circuitry and UNITY GAIN ADJUSTMENTS with a straight wire. Power need not be on in this mode. |
| D) EQ LINE button | Inserts equalizer circuitry into the playback or monitor line, but equalizer does not affect tape recordings made in this mode. |
| E) EQ TAPE button | Inserts equalizer into taping circuitry for recording pre-equalized tapes. |
| F) TAPE MONitor button | Standard tape monitor circuit for monitoring the actual recorded signal, as it is being recorded on tape. Also used for pre-recorded tape playback. |
| G) UNITY GAIN ADJUSTMENTS | Allows for ± 15 dB overall gain adjustment |
| H) Equalizer octave controls | Allows for ± 15 dB selective equalization in each audible musical octave. |

Rear Panel Connections

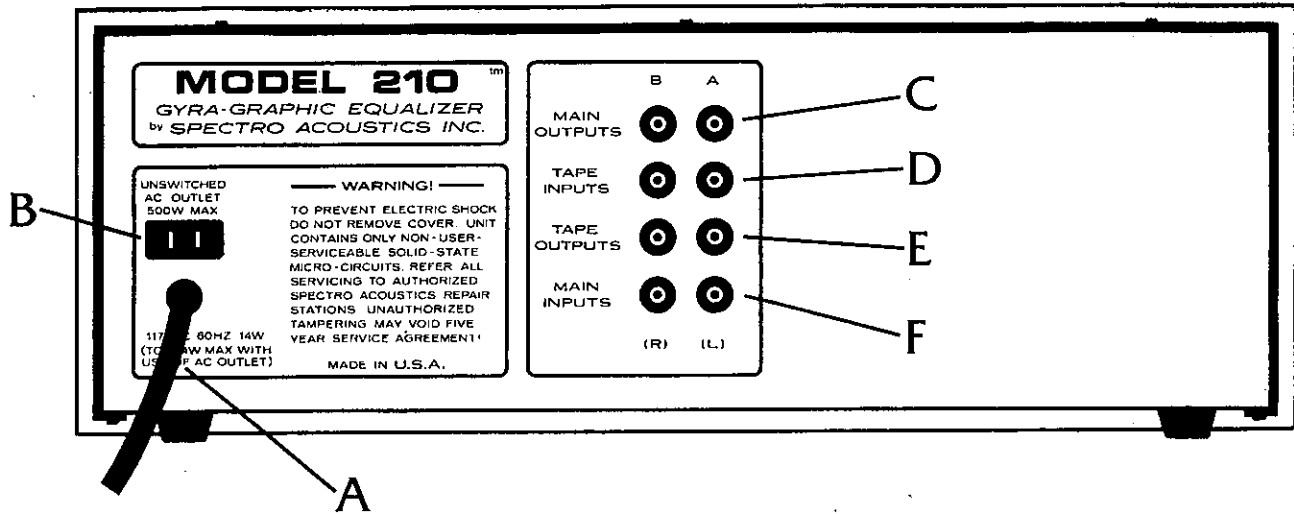

FIGURE VI REAR PANEL

| <u>CONNECTION NAME</u> | <u>CONNECTS TO:</u> |
|--------------------------|---|
| A) AC line cord and plug | Any source of 110 to 125 volts, AC, 60 Hz. The equalizer itself will require no more than 14 watts @ 117 VAC. (About as much as a typical electric clock) |
| B) Accessory outlet | This unswitched outlet is provided for powering additional equipment with a nameplate rating of up to 500 watts. It is "live" any time the Model 210 is plugged in to a "live" outlet. |
| C) MAIN OUTPUTS | The signal at these jacks is the signal you will hear. They are normally connected to the "TAPE INPUTS" on your preamp, receiver, or integrated amplifier. (See HOOKUP INSTRUCTIONS, next section.) |
| D) TAPE INPUTS | These inputs are always connected to the "LINE OUTPUTS", "MONITOR OUTPUTS", or "HIGH LEVEL OUTPUTS" of your tape machine. |
| E) TAPE OUTPUTS | The signal at these outputs is the signal your tape machine will record. They will always be connected to the "LINE INPUTS" or "HIGH LEVEL INPUTS" on your tape machine. |
| F) MAIN INPUTS | The program material is fed to these jacks. They will normally be connected to the "TAPE OUTPUTS" of your preamp, receiver, or integrated amplifier. (See HOOKUP INSTRUCTIONS, next section.) |

HOOKUP INSTRUCTIONS

A few simple rules to follow when hooking up your Model 210 Graphic Equalizer will assure proper operation the first time, and maximize the performance of the entire system.

- I. Always connect an input of one piece of gear to an output of another, and vice-versa. Never connect two outputs together or two inputs together. Remember, opposites attract!
- II. Always connect your Model 210's inputs to a source of line level signals. Never connect the 210 directly to a phono cartridge, microphone, tape head, or any low level source. The tiny noise signal contributed by the 210 is absolutely inaudible against a line level signal, but, since it remains at a constant low level, feeding the unit with very low level audio signals such as those from a phono cartridge, will result in audible noise. In other words, the larger the audio signal fed to the 210, (or any piece of equipment designed for line level operation) the better the signal to noise ratio will be. Overdriving the model 210 is next to impossible, since even at worst-case control settings it can handle five volts peak to peak without clipping! Normal control settings allow even more headroom, and ultimately, with all controls set to flat, the 210 will easily handle 25 volt peak to peak signals.
- III. Use shielded audio type cables with standard phono plugs on both ends for all system connections. Adapters may be used if your present equipment uses European DIN connectors. All cables, especially those leading to the model 210 input connectors, should be kept to a reasonable length for best performance. Six feet or less is considered reasonable in this case.

Your Model 210 Graphic Equalizer has been designed to be compatible with all commercially available Hi-Fi equipment. It can be connected into any system that provides either tape monitor facilities or access to the preamp outputs and power amp inputs. If you encounter any difficulties in integrating the Model 210 with your particular system, please feel free to contact Spectro Acoustics Service Department or seek assistance from the retail outlet where the Model 210 was purchased.

TAPE DECK CONNECTIONS:

The Model 210 can be used with any tape deck or recorder, whether open reel, cassette, or eight track cartridge, as long as line level inputs and outputs are provided on the machine. Nomenclature varies from one manufacturer to the next, but line level inputs are generally called "LINE INPUTS" or "HI-LEVEL INPUTS". The outputs are usually labeled "LINE OUTPUTS", "MONITOR OUTPUTS", or "HI-LEVEL OUTPUTS". Do not connect the Model 210 to "MIC INPUTS" or "SPEAKER OUTPUTS" without first consulting the factory for proper matching instructions!

Once you have located these inputs and outputs on your tape machine, simply connect the tape machine's line level inputs to the "TAPE OUTPUTS" on the Model 210. Then connect the Model 210's "TAPE INPUTS" to the line outputs of your tape machine. Be sure that the left and right channels maintain their integrity.

NORMAL SYSTEM CONNECTIONS:

If your system includes tape monitor facilities, this hookup will be generally preferred. Since your tape machine is now connected directly to the Model 210, these tape monitor facilities are free to be used otherwise. Most preamps, receivers and integrated amplifiers have provision for at least one tape machine, including tape monitor switching. Nearly all gear that has provision for two machines uses "TAPE 1" as the master tape machine, and "TAPE 2" as slave. The master machine is set up so that it can record from any selected source, and in most systems is the better of the two machines. The second tape deck can record from any source also, and additionally, can record from the outputs of the master machine, for "TAPE COPY" purposes. Many fine systems employ "bypass copying" circuitry so that copies can be made from machine 1 to machine 2 while listening to any selected source. If your preamp, receiver, or integrated amplifier has provisions for two machines, the following discussion will refer to the "TAPE 1" inputs, outputs, and monitor switch.

Connection of the Model 210 to the tape monitor circuitry of your equipment is normally preferred because this type of connection puts the volume, balance, and tone controls after the tape system and Model 210, so that these controls will have no effect on any recordings made. They will only control the playback, or the signal that you hear.

To implement this tape monitor connection, simply connect the Model 210's "MAIN INPUTS" to the tape outputs of your equipment. Conversely, connect the equipment's tape inputs to the Model 210's "MAIN OUTPUTS". Your preamp, receiver or integrated amplifier must then be switched permanently to its tape monitor mode, so that the audio signal must flow through the Equalizer, and to the tape machine, before it returns to be "monitored".

Normally, the tone controls on your existing equipment, if any, will be set to flat response or bypassed, so that the Model 210 can take over the job of equalization. Any additional equalization would tend to destroy the graphic display of frequency response as plotted on the face of the 210.

SPECIAL APPLICATIONS:

In certain systems a different setup may be required or desired:

- A) Your existing equipment does not have tape monitor circuitry.
- B) Your existing system includes certain signal conditioners that you wish to employ during recording, and are not separate units. (Noise reduction circuits, dynamic expanders or compressors, etc.)**
- C) You prefer that your preamp's volume, balance, and tone controls have an effect on the recording process, and that these effects be before the tape machine's inputs.

**Outboard processor units such as Dolby, Burwen, DBX, or the like, if desired that their effects be inserted prior to the tape machine so that their effects modify the actual recording, must be inserted between the 210's "TAPE OUTPUTS" and the tape machine's inputs. In the case of outboard Dolby units, no other equipment should be inserted between the Dolby and the tape inputs.

If any of the above is the case, a different system connection is required. This connection scheme requires that the power amplifier inputs be accessible, and that the preamp (or mixer, receiver, tuner, guitar amp, etc.) have its outputs readily accessible. Of course, any system that utilizes a separate power amplifier provides these connection points. Many of the better receivers and integrated amplifiers also have these connections, which are usually found strapped by a jumper bar on the rear panel. To connect the Model 210 in this fashion, simply run cables from the system's output ("PREAMP OUT", "MIXER OUT", etc.) to the "MAIN INPUTS" of the 210. Then connect the Model 210's "MAIN OUTPUTS" to the power amplifier inputs. If the power amplifier has its own level or volume controls, these should be run wide open, and the volume or

Level controls on the signal source must be used to control loudness. This brings to mind the one disadvantage of this type of hookup: The preamp volume control will affect both the listening level and the recording level. While taping, then it will be more difficult to obtain the desired balance between listening level and recording level, for they are no longer separate. During recordings, should it be desired to lower or raise the listening level, the recorder's input level controls must be readjusted accordingly. This may prove to be a major drawback to the serious recordist, but can be circumvented by using the power amplifier level controls to change listening levels, while leaving the preamp controls stationary. If employing this technique, be aware that it is possible to overload the Equalizer or your preamp outputs if you try to get high volume out of a power amp whose volume controls are turned way down. No permanent damage will occur, however, so experimentation is encouraged.

Further applications assistance regarding the use of the Model 210 Graphic Equalizer will be rendered gladly upon receipt of a letter asking specific and relative questions. All correspondence of this type should be directed to:

APPLICATIONS ENGINEER
SPECTRO ACOUSTICS, INC.
P.O. Box 2190
Pasco, Washington 99302

To assist you in more thoroughly understanding the various functions of your Model 210, a group of flow-graph schematics is given on page 14 of this manual. Many questions can be answered through reference to these diagrams.

MODEL 210 FLOW-GRAPHS

The functional versatility of your Model 210 Graphic Equalizer is unsurpassed by any product of its kind. The user may select from eight modes of operation, depending on his needs at the time. This section of your manual will probably be very useful during the first few weeks of operation, as it not only gives a block diagram or flow-graph for each mode, but it clearly shows how the mode is implemented by means of the front panel pushbuttons, and gives a full description of the flow-graph and the typical uses of the mode. The graphs are presented as equations, where a certain combination of buttons pushed is equal to the particular schematic. Buttons pushed in are shown in black, and un-pushed buttons in white, with detail.

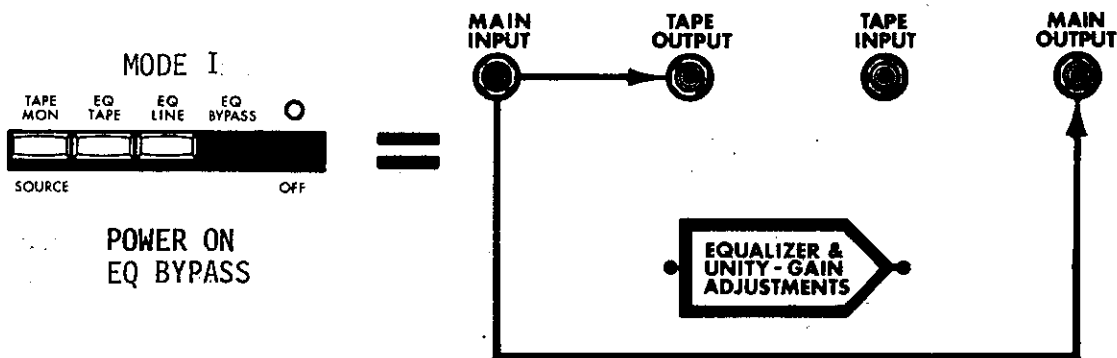

In MODE I, the audio signal flows, by direct wire, to both the "TAPE OUTPUTS" and "MAIN OUTPUTS". In this mode, all equalizer and unity gain adjustments are bypassed and unequalized tapes may be recorded. The signal you will hear is always present at "MAIN OUTPUTS" in all of these flow-graphs and, as you can see, in this case, it will be unequalized and totally unaffected by the equalizer and unity gain controls.

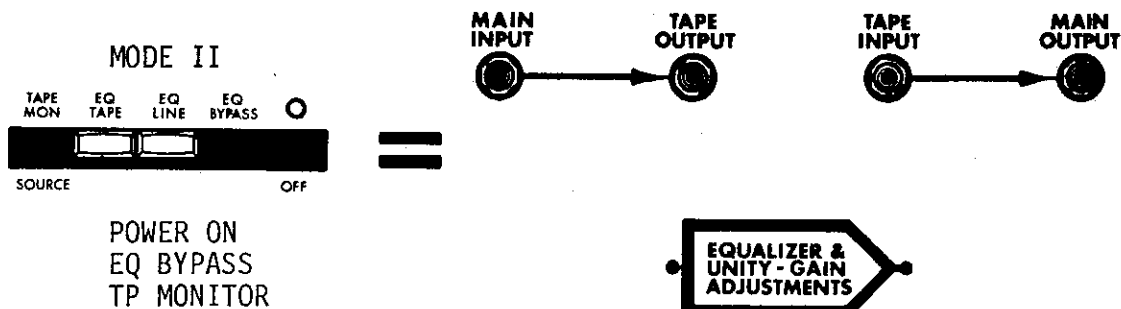

In MODE II, the audio signal again flows directly to the "TAPE OUTPUTS" to enable unequalized recordings, if desired. The "MAIN OUTPUTS" however, are now connected, by wire, to the "TAPE INPUTS" to enable tape monitoring. This mode is used also for normal playback of tapes without adding equalization.

The flow-graphs of MODES VII and VIII are identical to those of MODES I and II, respectively. The only difference is that the power switch is out, and the Model 210 need not even be plugged in. The EQ BYPASS modes don't require power, since the active electronics inside the Model 210 are totally bypassed.

RANGE OF ADJUSTMENT:

The twenty equalizer octave controls, ten per channel, control the amount and direction of the equalization in each individual musical octave. With all other controls set at center, each slider has the ability to either boost or cut sounds in its frequency band up to 12 to 13 dB. At first, this statement may seem to be in conflict with the specified ± 15 dB range of control. However, one must consider the effects of interaction between adjacent controls, a phenomena which occurs in all graphic equalizers which are correctly designed. Consider the graph given in figure VII, below, which shows the frequency response of the equalizer with all controls set at center except one, which is fully boosted.

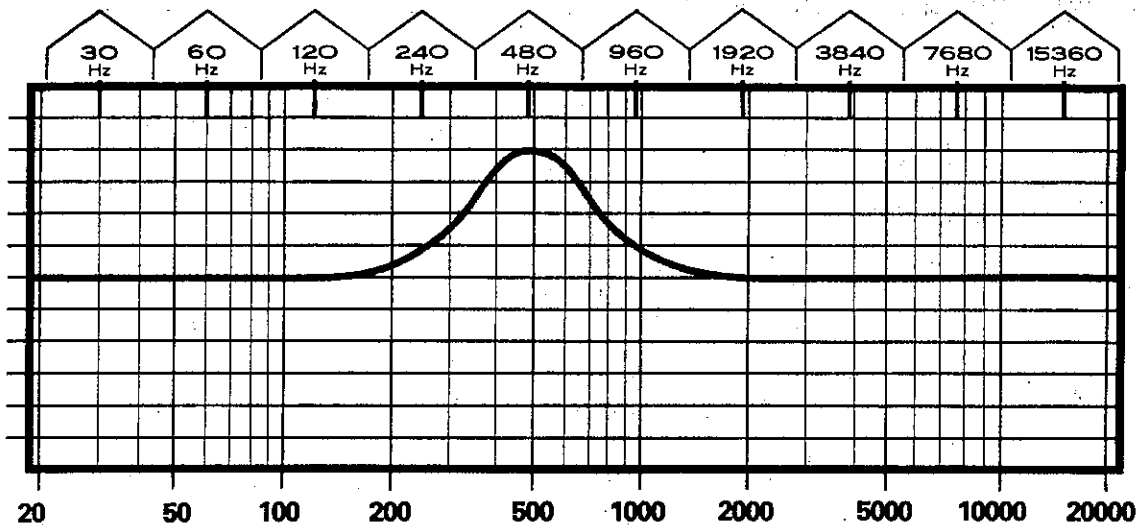

FIGURE VII FILTER SHAPE

Notice the general shape of the filter's response. It is not rectangular, with straight sides. In other words, the filter, centered at 480 Hz, has its most prominent effect right at 480 Hz, with gently decreasing, bell shaped sides symmetrically extending back to zero, or the flat response mark. For many reasons, the most important being that the gently sloping response causes a minimum amount of irritating phase distortion, all graphic equalizers on the market today utilize this very filter shape, with minor deviations depending on the number of bands in the equalizer. An important parameter of this filter response is the ratio of its height to its width. This parameter is called "Q", and determines the amount of boost and cut, the amount of interaction between adjacent controls, and the smoothness of the frequency response with all or several of the controls fully boosted or cut. Consider the graphs of figures VIII and IX on the following page. Figure VIII shows a very low Q filter's response centered at 60 Hz, and fully boosted. Superimposed upon this same graph is a similar filter's response, centered at 120 Hz, and also fully boosted. To the right of these two superimposed responses, a third overlay shows the responses of three low Q filters combined, and all three fully boosted simultaneously. These three are centered at 1920, 3840, and 7680 Hz. Notice that, although the wide shape (low Q) of these filters causes their response plots to cross each other between 60 and 120 Hz at a relatively high point, causing severe interaction between adjacent bands, their combined responses shown at 1920, 3840, and 7680 Hz provide smooth, ripple-free response when all three adjacent controls are fully boosted. The graph of figure IX is in a

similar format, except that the filters shown here are very high Q types. Notice that the 60 and 120 Hz plots do not intersect now, and therefore exhibit no interaction at all, but the combined boosted response shows a large amount of ripple in the boosted passband.

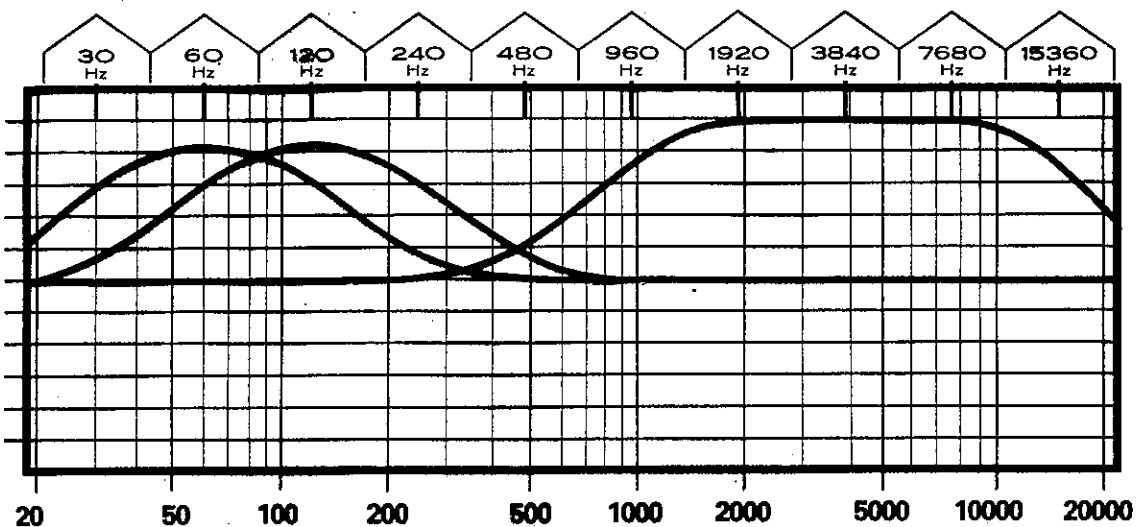

FIGURE VIII LOW Q RESPONSES Showing intolerable interaction, but smooth combined responses.

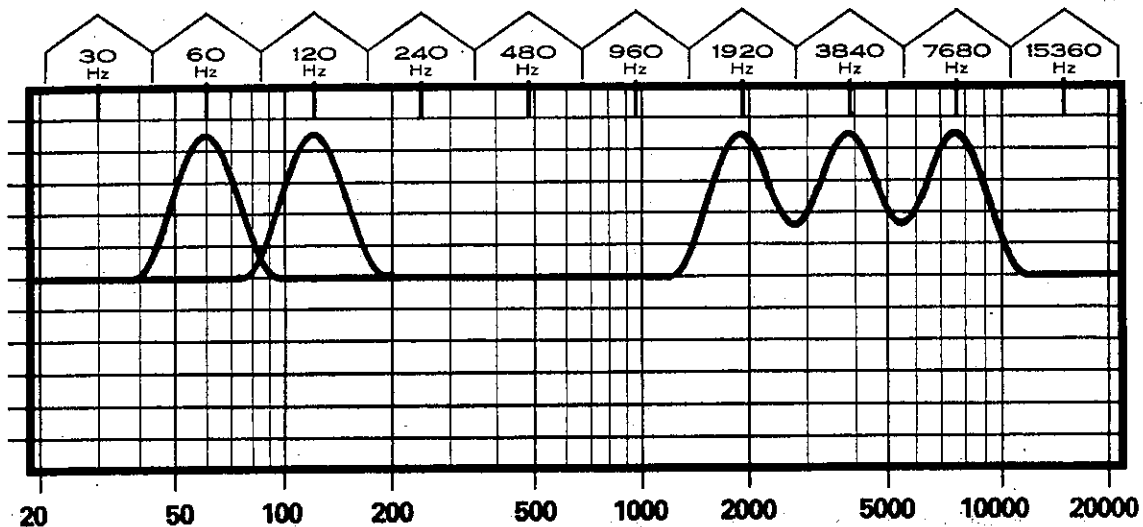

FIGURE IX HIGH Q RESPONSES Showing absence of interaction, but intolerable combined ripple.

The problem with the low Q design is that the extremely wide filter response causes intolerable interaction, which would mean that frequency selectivity would suffer (one could not boost 60 Hz without considerably boosting 120 Hz also). On the other hand, using high Q filters solves the interaction problem, but gives intolerable ripple when two or more filters are boosted or cut together. (Unwanted dips and peaks in the overall response)

The solution is of course, to compromise between the two extremes, and utilize filters with a medium Q characteristic, such as used in the Model 210. The Model 210, therefore, will exhibit responses in which only a small amount of interaction occurs between adjacent channels, and combined response ripple is nonexistent until, at the very extremes of boost and cut, it has a very small effect. To insure that all of the filters in your Model 210 will main-

tain this optimized Q performance, Spectro Acoustics has used highly stable tuning elements in all filter positions, and the unique Gyration synthesis employed in fabricating "inductors" for the Model 210 inherently insures Q stability.

To return to the question of range of adjustment, the full ± 15 dB of available adjustment range can be obtained by using the extra few dB caused by interaction of adjacent elements. This amount of boost or cut can be had by simply boosting or cutting the adjacent band controls along with the one in question.

CORRECTIVE EQUALIZATION:

The Model 210 can be used to perform two basic types of equalization. Under the heading of corrective equalization, it can be used to flatten the otherwise incorrect frequency response of a room, a set of speakers, a microphone, or any link or combined links in the recording or reproducing chain. In order to perform true corrective equalization, however, the response of the signal to be corrected must be known. Several methods of accomplishing this measurement and correction have been used, the most accurate of which involves the use of sophisticated and expensive sweep generators, calibrated microphones, and chart recorders. Several equalizer manufacturers provide the buyer either with a recording or a pink noise generator, which can help to provide a test reference for corrective equalization. However, the final measurement and therefore correction, in a system such as this cannot provide truly flat response, and the overall error in correction would vary from ear to ear, since the ear, with its own vast deviations from flat response, is invariably used as the measurement instrument in such systems. We at Spectro Acoustics, Inc. feel that the few instances in which our customers might desire to use such a test record or pink noise source do not warrant the inclusion of such a device with the Model 210. We are sure that the buyers of equalizers which do include such devices undoubtedly do rush home, hook up their new unit, play the test record, and immediately equalize their room/speaker combination for "flat" response, and probably leave the equalizer set up that way for about ten minutes! In other words, in order for these test records and such to do any good, the user would have to set up his equalizer controls once, and then leave them be at least until he changed speakers or moved his furniture, at which time he would whip out his test record again and so forth. How many people do you think really do this?

We feel that so few people would actually make use of this novelty, that to include such a device (which of course, would have to be reflected in the cost of your Model 210, whether you used it or not!) would penalize those who would rather equalize their records and tapes to their liking, than to some illusive "flat" response. However, if you disagree with this philosophy, and would care to voice your opinion by commenting on your warranty card or by letter, Spectro Acoustics, Inc. will be glad to register your opinion, and should it become apparent, through your responses, that a test record or pink noise generator is widely desired, we will make one or the other available at a nominal fee for those who desire it. The test records made by our competition are fully compatible with the Model 210, in any case, and for those of you who absolutely have to have a test record, you may be able to buy, borrow or acquire one from your local Hi Fi Store.

CREATIVE EQUALIZATION:

As previously mentioned, most of the equalization done in the home or the recording studio is done using desirability of sound as the final criterion, rather than "flat" response. Although this type of equalization could be "corrective" in some aspects, it generally falls into the category of creative equalization. That is, the person controlling the equalization controls is creating a sound of his own liking, rather than trying to correct for absolute flat response. It is in this type of equalization that the musical sound is emphasized, rather than meaningless numbers. After all, the reason for owning an equalizer is to more fully enjoy music, is it not?

The Model 210 provides all the flexibility and range needed to alter the tonal characteristics or "color" of any program material fed to its inputs. The Model 210 can be used as a sharp cutoff high filter to eliminate noise from old or noisy recordings. Notice that the three highest bands 3840, 7680, and 15,360 Hz. contain nearly 100% of all tape hiss, record surface noise, and hiss in general. Cutting one or more of these bands, especially the 15,360 Hz band, can reduce noise considerably without too much effect on the music material, in many cases. Hum can be reduced in a like manner, by cutting the 60 Hz control. Certain instruments can be either accentuated or muffled, using the octave controls which contain the energy spectra of the instrument. Voices can be brought out of a muddled menagerie. One very revealing use for the model 210 is in live recordings made in a large auditorium or theater. If you have ever tried to do a recording of this type, in a large reverberant room, using stereo microphones placed at the rear of the room, and usually not separated too well, you are aware of the severely muffled and muddled sound that sometimes will result. Using the equalizer, either upon recording or playback, can result in greatly improved definition on such "ultra-ambient" and resonance plagued recordings.

In the recording studio, equalizers are used to a large extent on individual channels; especially the bass guitar, piano, and vocal tracks, in the process known to recording engineers as "getting a sound". This refers to the process of enhancing the instrumental or vocal signal on an individual basis to obtain the desired effect. This same process can be done, in the home, to a large extent using the model 210. "Punch" can be added to the bass guitar or bassoon. "Fullness", "presence", "airyness", "sock", "crispness": all can be achieved by simply manipulating the equalizer controls. "Boominess", "grain", sibilance, harshness; reduce these annoying effects, simply by use of the appropriate equalizer controls. We can't tell you how to equalize, even if we want to, because you, for the first time, will be able to fully control the sound that you hear. We recommend that you set up your model 210 and put on your favorite recordings...play! experiment! enjoy yourself, while you teach yourself the infinitely intricate and satisfying art of equalization.

To aid you in your experimentation, we have compiled a spectral graph of many common musical instruments. This graph, appearing on the next page, shows the range of these instruments in octave bands, as superimposed on the familiar frequency plot which shows exactly which equalizer bands will contain the musical energy of each instrument, and therefore, which octave controls to use in either boosting or cutting the sounds of these instruments. The graph is intended to show not the extremes of each instrument, but its main frequency components and the bands which will, in general, control the sound of each instrument.

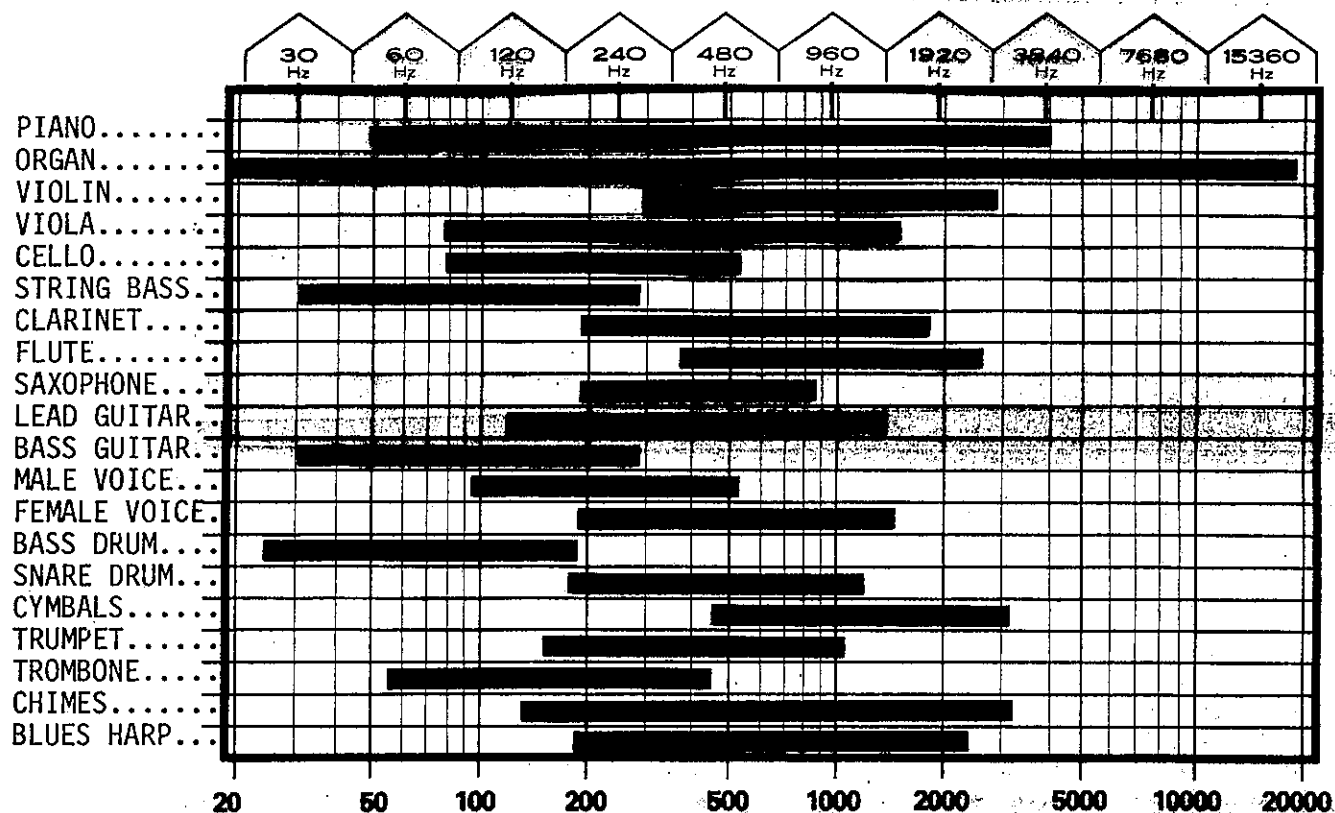

FIGURE X MUSICAL INSTRUMENT SPECTRUM

HELPFUL HINTS:

A few tips to help you get the best performance from your model 210, as well as providing you with the most convenient way of using the unit:

First, it is generally a good idea to do your equalizing as close to center as possible. In other words, as an example, there are numerous combinations that will give identical response, such as having all controls centered except one, which is cut 6dB. The same response could be had by boosting all controls 6dB except the one, which would be centered. Or, on the other hand, all controls could be cut 9dB except the one of interest, which would then be cut 15 dB. All three patterns would give similar frequency response, but the first one (the one where the biggest number of controls is the closest to 0dB) would be the best choice. This is due to the fact that noise and distortion, although extremely low at any setting, are optimized when all controls are set flat. Also, the size of signal that the Model 210 can handle without distortion-causing overdrive is maximized with this type of setup. These considerations, in 99 out of 100 cases, are totally inconsequential, but, as a general good practice, should be observed whenever possible. Remember, the noise, distortion, and signal handling capacity of the Model 210 are unquestionably the best in the industry, by far, but it is possible to overdrive the unit with extreme settings and mismatched accessory equipment. Also, the receiver or preamp you are using in conjunction with the Model 210 probably do not have the signal handling capacity of the 210 (unless they are Spectro Acoustics units) and may be overdriven by extreme settings of the equalizer, especially if the UNITY GAIN CONTROLS are not properly adjusted. As stated before, there is not much chance of this happening, unless the equalizer is severely misadjusted, and your other equipment is not capable of handling above-average signals. For the technically

curious, the worst-case for overload in the Model 210 is when all of the equalizer controls are fully cut, and the unity gain adjustments are fully boosted. The equalizer will still handle a full 2 volts rms at its inputs in this case, however, so overload should not be any problem. (This is the worst-case condition that provides overall unity gain; all controls fully boosted, providing 30 dB of gain is the mis-adjusted worst-case, in which ten volts rms are available at the output without clipping, or 316 mv at the input.) As you can see, the Model 210 indeed boasts far superior headroom to its comparable competition, a unit whose headroom characteristics are so weak that the manufacturer actually is forced to add indicator lights to the circuit to force the user to operate the unit at best-case conditions! The worst-case headroom of the Model 210 compares very favorably with the best-case headroom of most other units.

From a standpoint of user convenience, an excellent suggestion for the audiophile who wishes to recrod his albums on tape is to pre-equalize each album as it is being recorded, for each album or even each track may require different equalization settings. In this way, the user will not need to re-set the equalizer for each recording upon playback, and playback of the pre-equalized tapes can be done in EQ DEFEAT mode.

Another possible suggestion is, if the Model 210 is used to compensate for deficiencies in room acoustics or speaker resonances, two Model 210s could be employed, with one being used for creative equalization and tape equalizing (this unit should be connected in the tape monitor circuit) and the other unit, permanently adjusted, and left permanently in the EQ LINE mode would correct for the room/speaker deficiencies (this unit should be inserted directly before the system power amplifier).

Alternately, the Model 210 can be used with the Spectro Acoustics, Inc. Model 101 Preamp/Equalizer, which employs a five band graphic program equalizer. The program equalizer would then be used for tape and "tone control" equalizing, and the Model 210 would serve ahead of the power amplifier, as a room/speaker compensator. The possibilities are unlimited.

UNITY GAIN ADJUSTMENTS:

Since the use of the octave band controls on the Model 210 can cause a change in the overall amplitude of the signal by as much as 15 dB, a UNITY GAIN ADJUSTMENT is provided on the front panel for each channel. It is intended to be used to compensate for overall boosts or cuts in the signal's amplitude or loudness caused by the various boost and cut positions of the octave controls. The term "unity gain" is the correct scientific expression for any network whose overall output signal is the same amplitude as its input signal. Without the use of these two controls, if most of the octave controls were boosted, there would be a boost in the overall output signal, as compared to the input. Likewise for cut, except that there would then be a loss associated with the output signal. Proper adjustment of these UNITY GAIN CONTROLS will help to insure the proper and undistorted operation of the equalizer, as well as enabling valid EQ IN/EQ OUT comparisons to be made. In other words, if you had performed equalization to your liking, and this resulted, as it nearly always will, in an overall boost or cut in the signal's apparent loudness, comparisons of the equalized signal with the EQ BYPASSED signal would not really be fair, since the equalized signal would be at a different loudness level. The UNITY GAIN CONTROLS are provided to adjust the loudness of the equalized signal, so that it will appear to be of equal loudness to the EQ BYPASSED signal.

UNITY GAIN ADJUSTMENTS...method for recording

While setting up to do recording of pre-equalized tapes using the EQ TAPE mode, the following procedure will conveniently allow you to very accurately adjust the UNITY GAIN controls for optimum equalizer performance.

Set the Model 210 pushbuttons for MODE VI operation: Pwr. on, EQ TAPE, TAPE MON. (See flow graph, page 16) Record a "test take" of the material to be recorded, and during this recording, adjust the equalizer octave controls for the desired equalization characteristics, being careful not to overdrive the tape machine by observing the record level meters on the tape recorder. The sound you are now monitoring is the exact sound that has been recorded on the tape, so the equalizer is truly adjusted for total system response, including any deviations introduced by the tape machine itself. Once the equalization desired has been accomplished, switch from MODE VI to MODE II, by pushing the EQ BYPASS button. With the tape machine still running and recording, adjust its input level controls for optimum record level so that the musical peaks are just reaching 0 dB on the machine's level meters.

Now, switch back to MODE VI by pushing the EQ TAPE button, and adjust the UNITY GAIN ADJUSTMENTS so that the recorder's level meters show the same record level as in EQ BYPASS. To "fine tune" this adjustment, the ear can be used. Switching back and forth between the EQ TAPE/ TAPE MON mode and the EQ BYPASS/TAPE MON mode, tweak the UNITY GAIN controls for the desired balance and for equal overall loudness in either mode.

Remember, due to the outstanding signal handling capacity of the Model 210, these adjustments are not really very critical in terms of equalizer performance, so in any case, it may be simpler to disregard the recorder's meters at first and just listen to obtain unity gain operation. Do be sure, however, that before recording the real "take", the recorder's level meters register the highest levels possible without running into the red or over 0 dBm. This will insure the very best signal to noise ratio your recorder can offer.

UNITY GAIN ADJUSTMENTS...method for playback

While using the equalizer in its EQ LINE modes, the UNITY GAIN ADJUSTMENTS should be set in the following manner: While listening to the program material (push TAPE MON to hear pre-recorded tapes from the machine hooked to the 210) push EQ LINE and equalize for the desired sound. Once the octave band controls are set, simply switch back and forth between EQ LINE and EQ BYPASS, and adjust the UNITY GAIN controls for no change in overall loudness and balance. When these conditions are met, the equalizer is correctly set.

HEADROOM CONSIDERATIONS:

As previously mentioned, the Spectro Acoustics Model 210 is far ahead of its competition in terms of maximum signal-handling ability, or so-called "headroom". Using comparable quality equipment in conjunction with the model 210, you can be sure that, under all normal operating conditions, the 210 will not clip or distort even at the highest output or input levels. Its integrated circuit servo op amp output stage can directly drive as many as ten super power amplifiers in parallel without a sigh or gasp, and with no loss of bass. With the controls set to center, or the EQ BYPASS button in, the 210 will easily handle upwards of 25 volts peak to peak or ten volts rms and, even with the worst-case unity gain combination of adjustments, the equalizer can comfortably handle 5 volts peak to peak or two volts rms.

CLEANING:

To keep your Model 210 Graphic Equalizer clean and looking like new, occasionally clean the front panel with a soft paper towel or lint-free rag and full strength ammonia. Parsons sudsing ammonia, available in all supermarkets is the particular brand we use in pre-shipment cleaning, and seems to be highly effective and residue free. Using these techniques, the dulling films and finger smudges which tend to build up on the brushed aluminum finish can be effectively removed, without damage of any kind to the anodized finish or epoxy ink lettering.

Cleaning of the top, bottom, back and sides can be accomplished in the same manner.

WARNING!!!!!!..... DO NOT ATTEMPT TO CLEAN THE SLIDER CONTROLS INTERNALLY USING COMMERCIALY AVAILABLE "TUNER CLEANER" OR EQUIVALENT PRODUCTS. THESE PRODUCTS MAY DISSOLVE THE SILICONE LUBRICANT RESPONSIBLE FOR THE EXTREMELY SMOOTH TACTILE "FEEL" OF THESE CONTROLS. Should one or more of the slide pots become noisy due to contamination or residue, very carefully, using a toothpick and a small piece of paper towel or cotton swab doused in alcohol (one drop of alcohol!) clean the offending section of the control which is to be found directly behind the open slot in the front panel. We highly recommend that unless absolutely necessary, no chemicals of any kind be introduced into the potentiometer. Only with great patience and care can these controls be cleaned, and unless it becomes mandatory, it is best to leave them be.

REPAIR FACILITIES:

Only qualified technicians should be allowed to repair your Spectro Acoustics Model 210 Equalizer. The Spectro Acoustics factory and its authorized warranty stations have the personell, equipment, and know-how to provide proper service on your equalizer. Should you have trouble of any kind with your unit, ask your dealer or write to the factory for the name and address of the nearest authorized repair/warranty station. Please include the model number (Model 210) and serial number of your equalizer, along with a brief description of the problem.

RETURN AUTHORIZATION:

This is important! Spectro Acoustics will not accept units for warranty repair which are not accompanied by a RETURN AUTHORIZATION CARD. This is to protect us from having to pay freight bills on returned goods which are not truly defective. On many occasions, we have received units without RETURN AUTHORIZATION CARDS, whose only defect was a simple blown fuse or other user accessible, user serviceable part. In one instance, a customer returned one of our preamplifiers for warranty repair; the problem? A loose knob. Please do not expect us to pay the high cost of freight for a unit weighing 20 to 30 pounds, when it would have been possible to fix the problem by sending a 35¢ part in a 10¢ stamped envelope. The only way we are able to provide you with such good values in stereo equipment is by avoiding waste at all cost! We want you to be happy with your unit, and we do stand behind our gear with the most complete warranty package in the hi-fi market, so please help us by writing and telling us about your problems first. Then, armed with this information, we can best decide how to fix the problem. If it does become necessary to ship the unit, we will provide you with a RETURN AUTHORIZATION CARD by return mail. Thank you.

SHIPPING:

If it does become necessary to ship your Model 210 to the factory or an authorized repair facility, we will provide you with an AUTHORIZATION CARD, as mentioned under RETURN AUTHORIZATION page 25. It will contain instructions on where to ship the unit. Six things must be remembered in the event you have to pack one of our units for return shipping.

- 1) NEVER ship a Spectro Acoustics unit in any container other than the original box, with all foam corners and inner liner box, or a replacement supplied by Spectro Acoustics. For a free replacement, write to the factory, or see your local dealer. If the Model 210 is shipped in other than the original factory container, the shipping party (you) must pay for any damages occurring in shipping.
- 2) NEVER ship a Spectro Acoustics unit to an authorized factory repair depot without a return authorization card clearly visible on the outside of the box. We will provide this card upon receipt of a letter requesting service. See page 25.
- 3) NEVER ship your owners manual with your unit. The owners manual is your record of ownership, and warranty coverage. We do not need it, and it may become lost or damaged.
- 4) NEVER ship a Spectro Acoustics unit via PARCEL POST!!!! Ship only via a reputable carrier. UPS, or any of the larger truck lines will provide good, safe, and rapid delivery.
- 5) ALWAYS insure the unit for its full retail value. This is very inexpensive, and will be a great relief should anything happen to your unit in transit.
- 6) ALWAYS expect prompt service and delivery from Spectro Acoustics. The design of all our products is such that they can always be repaired rapidly, once they arrive at the service facility. In general, our warranty turnaround time in the factory is one day. Shipping, however, often takes as much as two weeks each way, so please be patient.

SPECIFICATIONS:

EQUALIZATION CHARACTERISTICS

Range.....allows 30 dB total adjustment, (± 15 dB)
Band Centers.....30 Hz, 60 Hz, 120 Hz, 240 Hz, 480 Hz, 960 Hz,
1920 Hz, 3840 Hz, 7680 Hz, and 15,360 Hz
Filter "Q".....2.5 nominal $\pm 10\%$

UNITY GAIN ADJUSTMENTS

Range.....full 30 dB total adjustment (± 15 dB)
Seperate adjustments for each channel

FREQUENCY RESPONSE

EQ BYPASS modes.....absolutely flat from DC to 1,000,000 Hz
EQ LINE or TAPE..... ± 0.25 dB from 20 Hz to 20,000 Hz all controls
centered

DISTORTION

IMD.....Guaranteed less than 0.0075% at any output
level up to 10 volts composite, 8.12 volts
rms as measured on average responding meter
Standard 4/1 mix of 60 Hz & 7000 Hz
THD.....Guaranteed less than 0.05% at 1 volt rms output,
20 Hz to 20,000 Hz, controls centered.
Less than 0.1% at 1 volt rms output, 20 Hz to
20,000 Hz, any combination of control positions
provided that the 2nd and 3rd harmonic frequencies
are being boosted or cut the same amount as the
fundamental frequency, to allow a valid THD
measurement.

TOTAL HUM AND NOISE

Scientific rating.....Equivalent input noise is less than 60 microvolts
rms with the very worst-case settings of the
controls(all equalizer controls fully boosted,
unity gain controls fully cut) Equivalent input
noise is less than 15 microvolts rms with all
controls set to center. All noise measurements
made over unweighted 20 Hz to 20,000 Hz bandwidth,
600 ohm source resistance. Noise voltage referred
to input in gain modes, to output in attenuation
modes.
Hi-Fi Industry rating....S/N is better than 90 dB below one volt
Dynamic range.....Noise floor is over 105 dB below full output
with normal control settings

OUTPUT CAPABILITIES

Output voltage.....capable of supplying 10 volts rms to normal
load impedance (10 K ohms) without clipping
Slew rate limiting limits undistorted output
to 5 volts rms at 20,000 Hz, to protect power
amplifiers from high frequency excursions
beyond their capacity.
Output impedance.....less than 600 ohms, fully protected against
short circuits. Will drive ten of any commer-
cially available power amplifiers at once, in
parallel, with no loss of bass.

INPUT IMPEDANCE

Nominal.....50,000 ohms
Minimum.....30,000 ohms, compatible with all commercially
available preamplifiers, receivers, tape decks, etc.

SPECIFICATIONS, cont.

IMMUNITY TO EXTERNAL MAGNETIC FIELDS.....TOTAL!
FREQUENCY ACCURACY.....Within 10% of marked value
TAPING FACILITIES.....Full tape monitoring and tape equalizing
features, as well as line equalization
and EQ BYPASS mode.
SIZE..... 17" W, 6" H, 6.5" D Model 210
19" W, 7" H, 6.5" D Model 210 R
Standard EIA rack mount version
POWER REQUIREMENTS.....110 to 130 volts AC, 50/60 Hz, 14 watts
SHIPPING WEIGHT.....12 pounds