

# TC-117

**REVISED**

*AEP Model*  
*UK Model*  
*US Model*  
*Canadian Model*  
*E Model*  
*AUS Model*

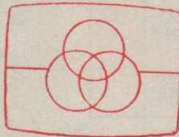

Free service manuals  
 Gratis schema's

Digitized by

[www.freeservicemanuals.info](http://www.freeservicemanuals.info)

## STEREO CASSETTE-CORDER

### SPECIFICATIONS

<b>Power Requirements:</b>	220, 240 V ac, 50/60 Hz (AEP Model) 110/120, 220/240 V ac, 50/60 Hz (E Model) 240 V ac, 50/60 Hz (UK, AUS Model) 120 V ac, 60 Hz (US, Canadian Model)	<b>Wow and Flutter:</b>	0.2% WRMS (NAB)
<b>Power Consumption:</b>	7 W	<b>Inputs:</b>	MIC . . . . . 2 Sensitivity 0.2 mV (−72 dB) for low impedance microphone LINE IN . . . . . 2 Sensitivity 0.06 V (−22 dB) Input impedance 100 kΩ
<b>Fast Forward and Rewind Time:</b>	Approx. 90 seconds (for C-60)	<b>Outputs:</b>	LINE OUT . . . . . 2 Output level 0.435 V (−5 dB) at load impedance 100 kΩ Suitable load impedance more than 10 kΩ HEADPHONES . . . 1 Suitable load impedance 8 Ω
<b>Recording System:</b>	4-track 2-channel stereo	<b>REC/PB Connector:</b>	Input impedance less than 10 kΩ (AEP, UK, E, AUS Model) Output impedance less than 10 kΩ
<b>S/N Ratio:</b>	With Ferri-Chrome Cassette and chromium dioxide cassette 46 dB at peak level (NAB) 40 dB (DIN) With standard cassette 44 dB at peak level (NAB)	<b>Dimensions:</b>	Approx. 362 (w) x 105 (h) x 238 (d) mm 14 <sup>1</sup> / <sub>4</sub> (w) x 4 <sup>1</sup> / <sub>8</sub> (h) x 9 <sup>3</sup> / <sub>8</sub> (d) inches Including projecting parts and controls
<b>Total Harmonic Distortion:</b>	3%	<b>Weight:</b>	Approx. 3.2 kg, 7 lb
<b>Frequency Response:</b>	With Ferri-Chrome Cassette and Chromium dioxide cassette 40 ~ 13,000 Hz (NAB) 63 ~ 10,000 Hz (DIN) With standard cassette 40 ~ 10,000 Hz (NAB) 63 ~ 8,000 Hz (DIN)		

# SONY®

## SERVICE MANUAL

# SECTION 1 BLOCK DIAGRAM

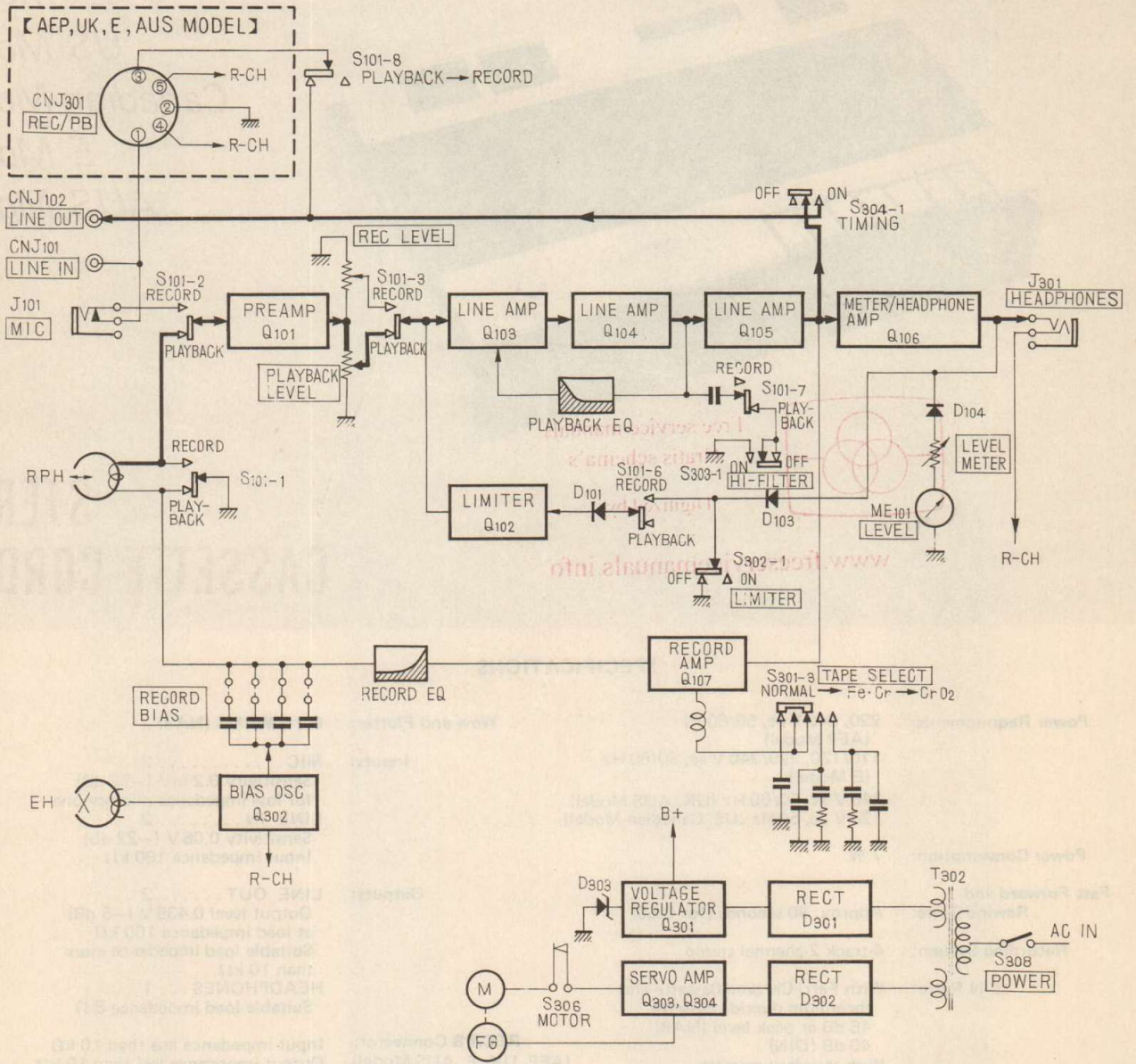

SECTION 2  
DISASSEMBLY

2-1. DISASSEMBLY

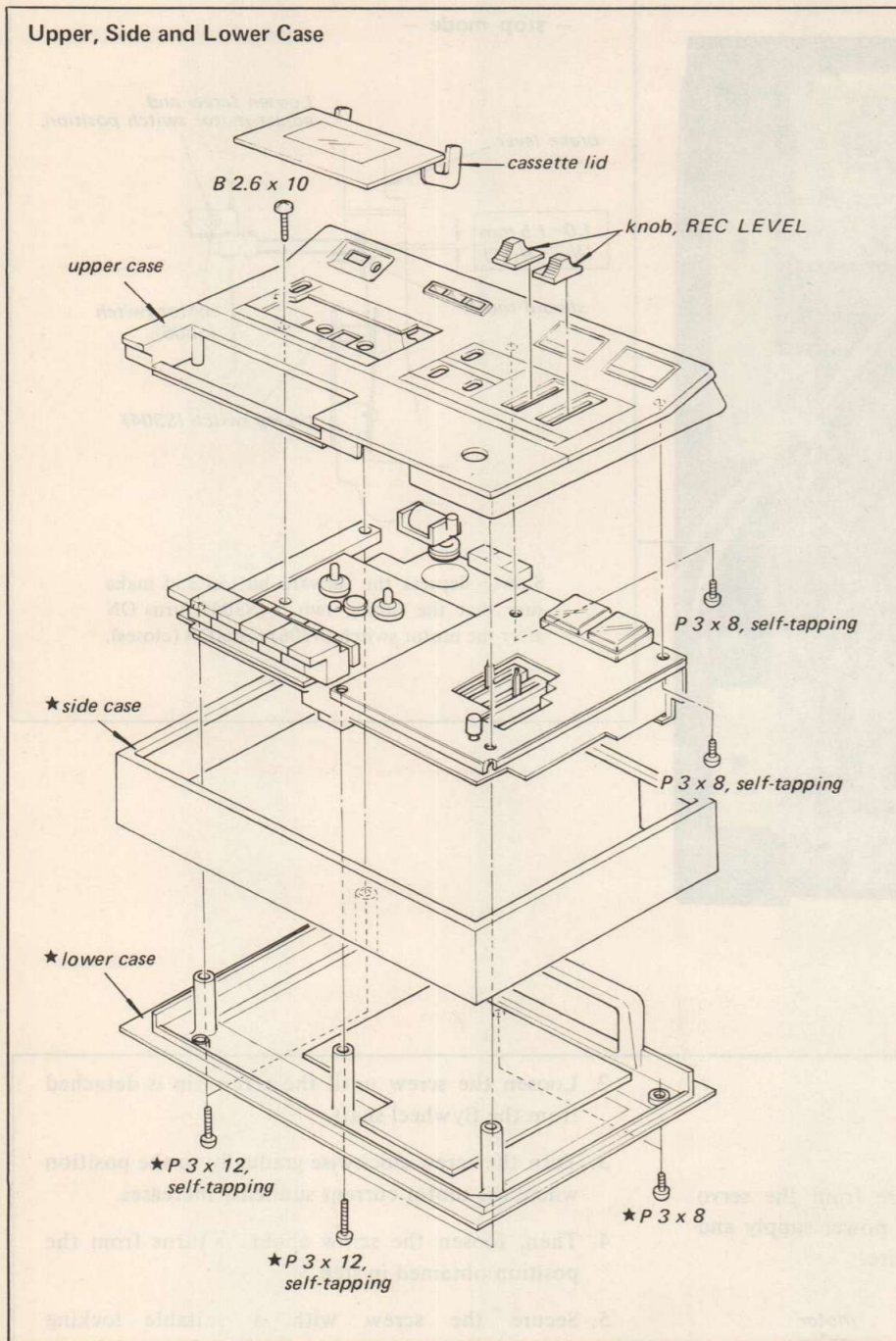

Remove the materials marked ★.

**MIC Jack Board**  
1. Remove a screw (K 3 x 8).  
2. Remove two nuts of microphone jacks.

**Switch Board**  
Remove four screws (PSW 3 x 6).

**Control Board**  
Remove four screws (PSW 3 x 6).

**Input/output Board**  
Remove plastic rivets (four).

**Timing Switch Board**  
Remove a screw (P 2.6 x 5).

**Servo Amp Board**  
Remove two screws (P 2.6 x 6).

1-3. CAUTION OF REPLACEMENT

**Record Switch Lever**

Place this side to the record/playback switch (S101, 201) direction.

**Control Board**

electrolytic capacitors

Place this side to the power switch (S308) direction.

**Voltage Selector Switch (E model)**

**Record/playback Board and Fuses**

SECTION 3

ADJUSTMENTS AND MEASUREMENTS

3-1. MECHANICAL ADJUSTMENTS AND MEASUREMENTS

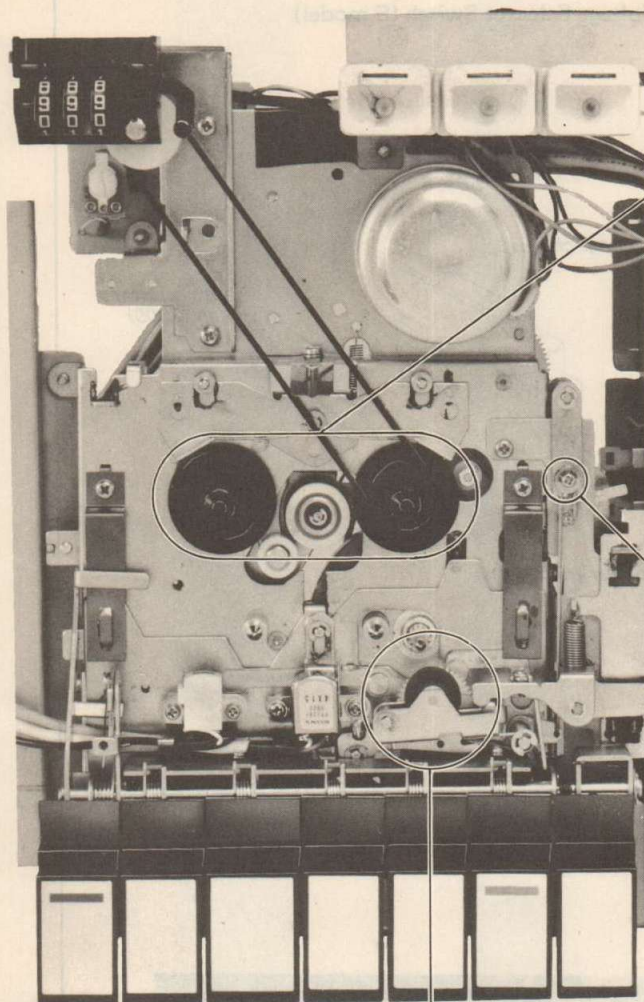

Torque Measurement

Specification:

Forward 30 ~ 60 g · cm  
(CQ-101A, 102A, 103A) (0.42 ~ 0.83 oz · inch)

Fast forward and 60 ~ 150 g · cm  
rewind (CQ-201A) (0.83 ~ 2.1 oz · inch)

If fast forward and rewind torque deviate from the specified value, bend the portion (marked ★) of the fast forward joint lever.

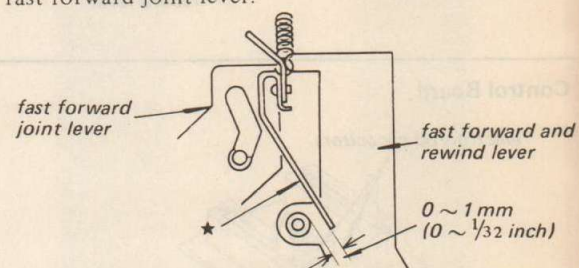

Automatic Shut-off Adjustment

In playback or record mode and with the POWER switch OFF, turn the take-up reel spindle in the direction shown by the arrow ① until the joint rod moves to the full in the direction shown by the arrow ②. At this time the cam gear and the capstan gear should completely mesh. If necessary, adjust the joint rod length by the adjustment screw.

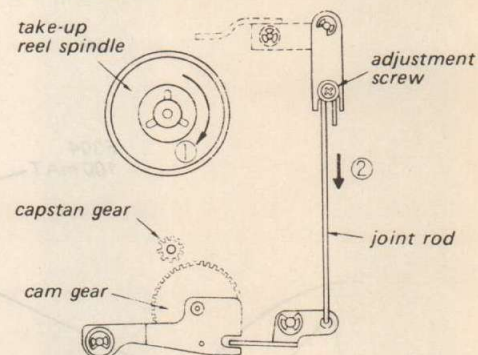

- Note:**
1. Just when the set is placed in playback or record mode, the clearance between the cam gear and the capstan gear should be more than 2 mm (5/64 inch).
  2. Automatic Shut-off Mechanism should operate within 5 sec. at the tape end.
  3. Automatic Shut-off Mechanism should not operate with mechanical shock during tape run.
  4. As soon as a tape cassette with no tape remaining on the supply side is inserted, Automatic Shut-off Mechanism should operate.

Pinch Roller Pressure Measurement  
— playback mode —

Pull the pinch roller away from the capstan using a tension gauge as shown by the arrow. Make the pinch roller return to the capstan slowly. The pressure should be measured at the point where the pinch roller just contacts the capstan.

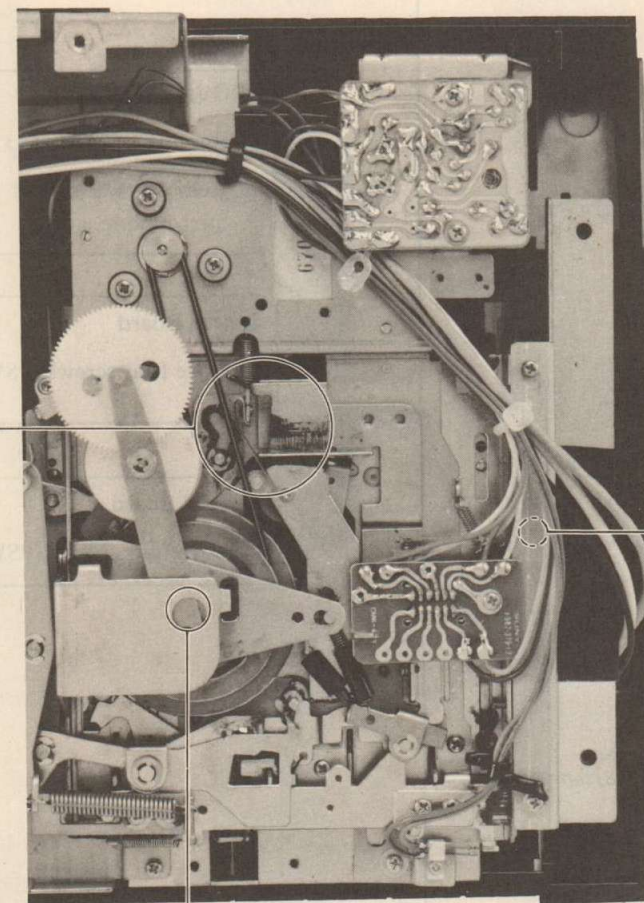
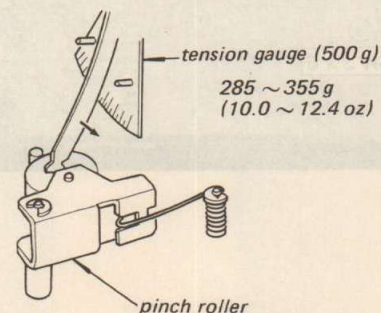

Motor Switch (S306) Adjustment

— stop mode —

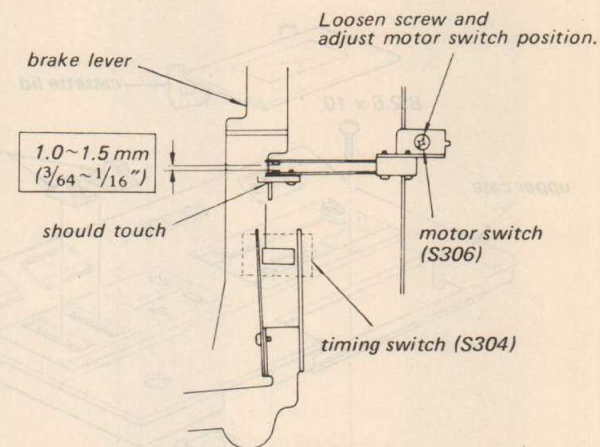

Slowly depress the forward button and make sure that the timing switch (S304) turns ON after the motor switch (S306) turns ON (closes).

Flywheel Thrust Play Adjustment

Procedure:

1. Disconnect the motor lead wire from the servo amp board and connect 6 V dc power supply and dc ammeter to the motor lead wire.

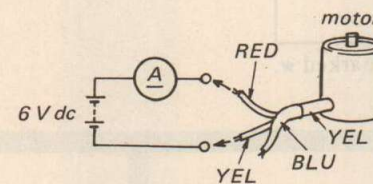

2. Loosen the screw until the screw tip is detached from the flywheel shaft.
3. Turn the screw clockwise gradually to the position where the motor current suddenly increases.
4. Then, loosen the screw about 1/8 turns from the position obtained in step 3.
5. Secure the screw with a suitable locking compound.

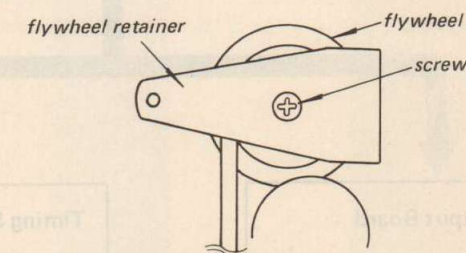

## 3-2. ELECTRICAL ADJUSTMENTS

## PRECAUTION

- Clean the following parts with an alcohol moistened swab:
 

* record/playback head	* pinch rollers
* erase head	* rubber belts
* capstans	* idlers
- Demagnetize record/playback head with a head demagnetizer.
- Do not use a magnetized screwdriver for adjustments.
- After the adjustments, apply a small amount of a locking compound to the parts adjusted.
- The adjustments should be performed in the order given in this service manual.
- The adjustments should be performed for both L-CH and R-CH with rated power supply voltage unless otherwise specified.
- The record and playback level adjustments should be carefully performed.
- Tapes required:
  - blank tapes (completely erased with bulk eraser)  
SONY CS-10 (HF)
  - test tapes
 

SONY P-4-A81S	(6.3 kHz, -10 dB)
P-4-A82	(10 kHz, -10 dB)
P-4-L81	(333 Hz, 0 dB)
WS-48	(3 kHz, 0 dB)
- The switches should be set as follows unless otherwise specified.
 

LIMITER:	OFF
TAPE SELECT:	NORMAL
HIGH FILTER:	OFF

## Normal Input Level

	MIC	LINE IN
source impedance	300 $\Omega$	10 k $\Omega$
input level	-60 dB (0.77 mV)	-10 dB (0.25 V)

## Normal Output Level

	LINE OUT
load impedance	100 k $\Omega$
output level	-5 dB (0.44 V)

## 1. Tape Speed Adjustment

## Procedure:

Mode: Playback

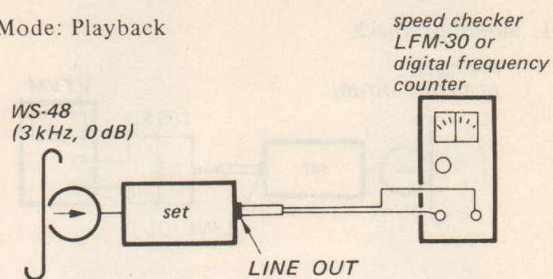

Adjust R314 to satisfy the specification.

## Specification:

speed checker	digital frequency counter
-1 ~ +1 %	2,970 ~ 3,030 Hz

Frequency difference between beginning and end of tape should be within 1 % (30 Hz).

## Adjustment Location:

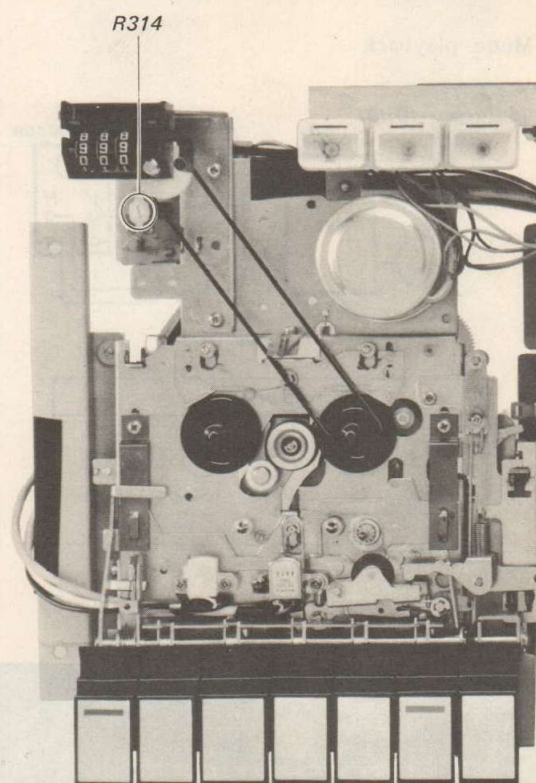

## 2. Record/playback Head Azimuth Adjustment

### Procedure:

1. Mode: playback

P-4-A81S  
(6.3 kHz, -10 dB)

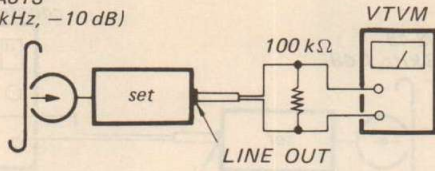

2. Turn the adjustment screw for the maximum level and set it the mechanical mid position of L-CH and R-CH peak position.

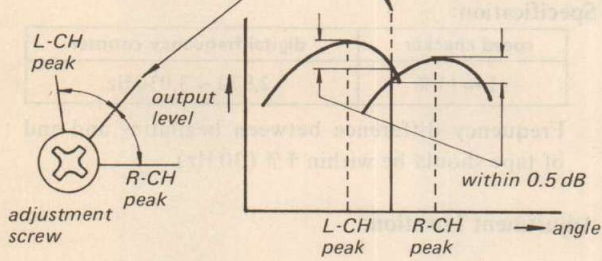

3. Mode: playback

P-4-A81S  
(6.3 kHz, -10 dB)

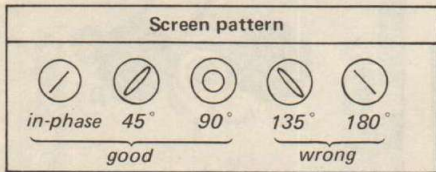
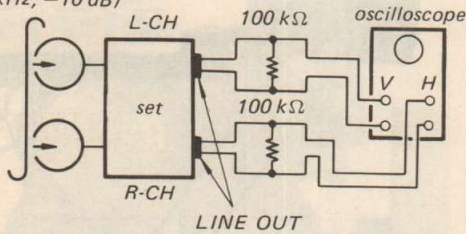

### Adjustment Location:



adjustment screw

## 3. Playback Level Adjustment

### Procedure:

1. Mode: Playback

P-4-L81  
(333 Hz, 0 dB)

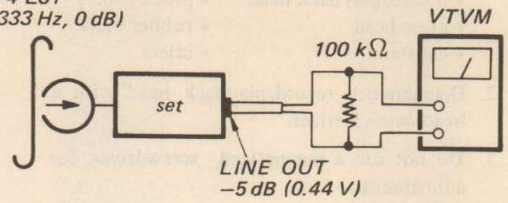

Adjust R109 (L-CH) and R209 (R-CH) to obtain the specified value.

2. Assure that the LINE OUT level does not change when the mode is changed from playback to stop several times.

### Specification:

LINE OUT level:  $-5 \text{ dB} \pm 0.5 \text{ dB}$   
(0.39 ~ 0.49 V)

Level difference between channels:  
less than 0.5 dB

### Adjustment Location:

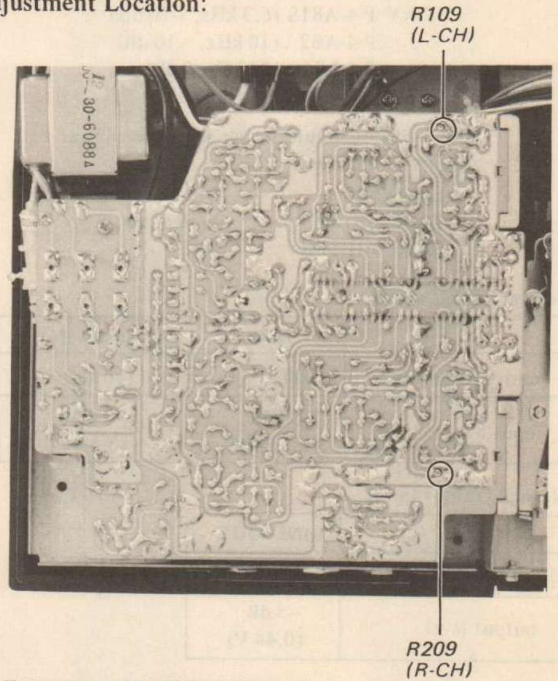

To increase the LINE OUT level, turn R109 (or R209) clockwise.

#### 4. Playback Equalizer Adjustment

##### Procedure:

1. Mode: Playback

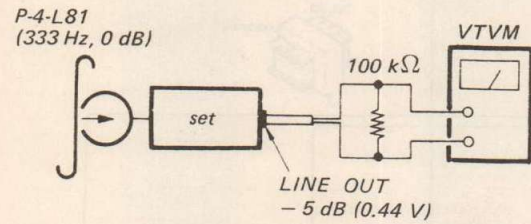

2. Mode: Playback

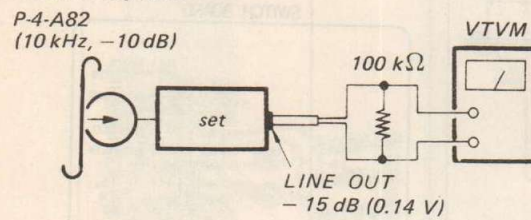

Adjust R118 (L-CH) and R218 (R-CH) to obtain the LINE OUT voltage 10 dB lower than that obtained in step 1 above.

##### Adjustment Location:

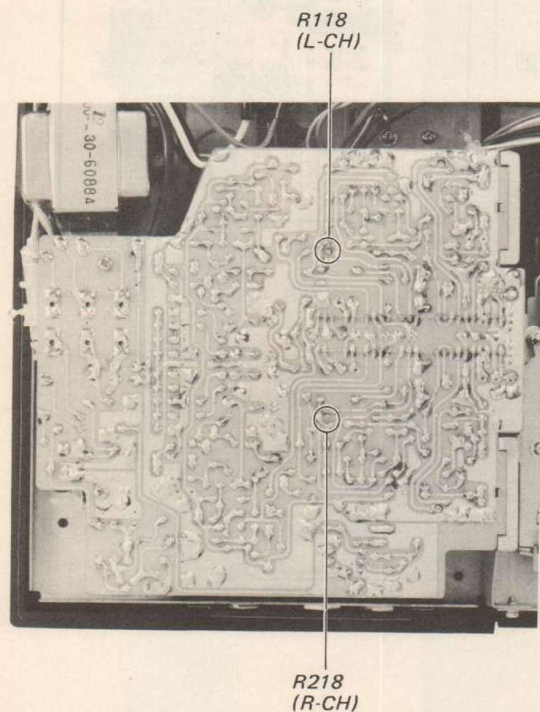

#### 5. VU Meter Calibration

##### Procedure:

1. Mode: Record

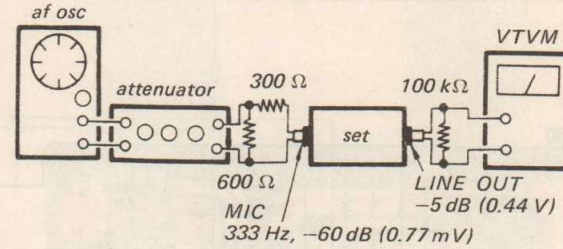

- 2.

Adjust	VU meter reading: 0 VU
R131 (L-CH)	
R231 (R-CH)	

##### Specification:

When adjusting the LINE IN level control to make 0 VU indication, VTVM reading should be -5 dB (0.44 V).

##### Adjustment Location:

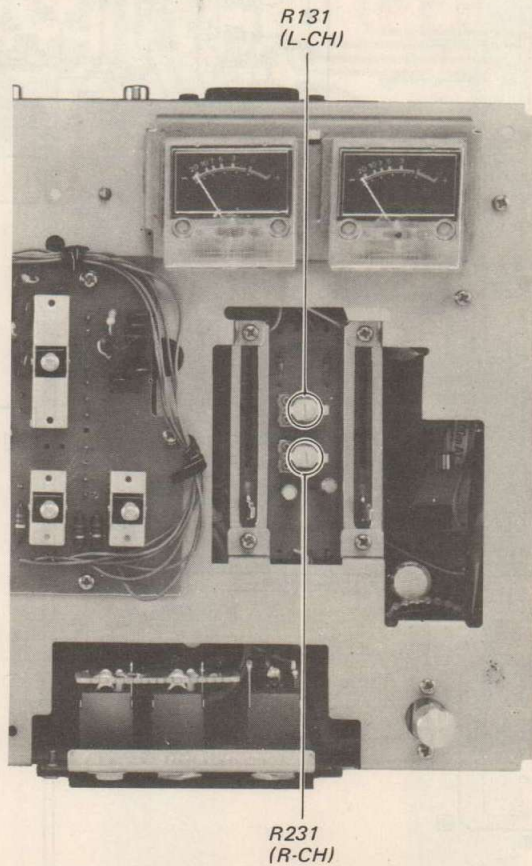

#### 6. Record Bias Adjustment

##### Setup:

##### Mode: Record

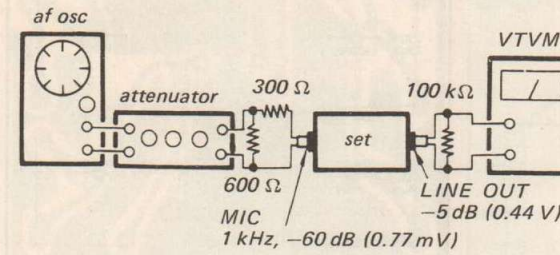

Adjust the REC LEVEL controls to obtain -5 dB (0.44 V) VTVM reading.

##### Procedure:

1. Mode: Record

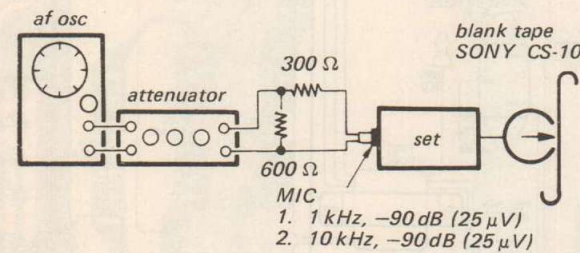

C137, 134  
135, 136  
(L-CH)

C237, 234  
235, 236  
(R-CH)

C137 22 p  
C134 29 p  
C135 33 p  
C136 39 p  
C236 39 p  
C234 27 p  
C237 22 p

If necessary, change the pattern connection (T301).

10 kHz response increases in order from ① to ④.

2. Mode: Playback

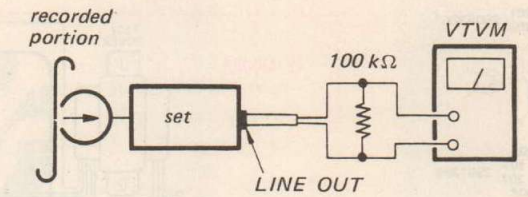

Adjust capacitance values by connecting patterns to satisfy the specified value. To increase the 10 kHz output level, decrease capacitance.

{ L-CH: C137, 134, 135, 136 }  
{ R-CH: C237, 234, 235, 236 }

##### Specification:

10 kHz output level is -3 dB lower than 1 kHz output level.

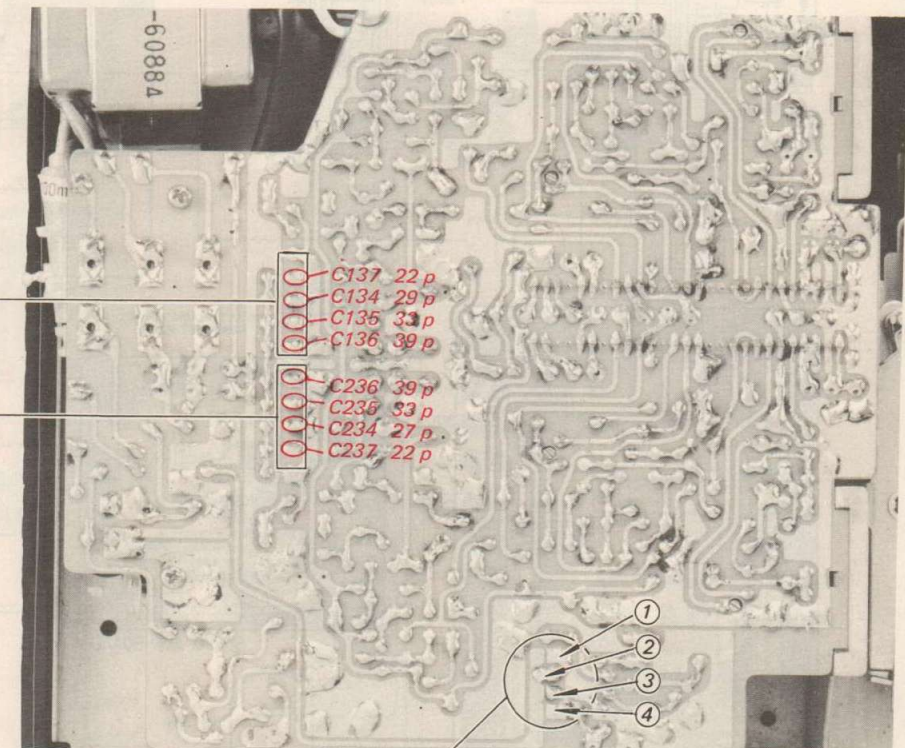

SECTION 4  
DIAGRAMS

AEP, UK, E, US and Canadian models of former type.  
The printed pattern on the record/playback and switch boards differs from the new boards.

- Note:
- indicates parts on the conductor side.
  - indicates lead wire connection on the conductor side.
  - indicates lead wire connection through the component side.
  - L-CH signal path
  - R-CH signal path

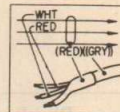

4-1. MOUNTING DIAGRAMS  
— Conductor Side —

Note: The parts printed in RED are for AEP, UK, E model.

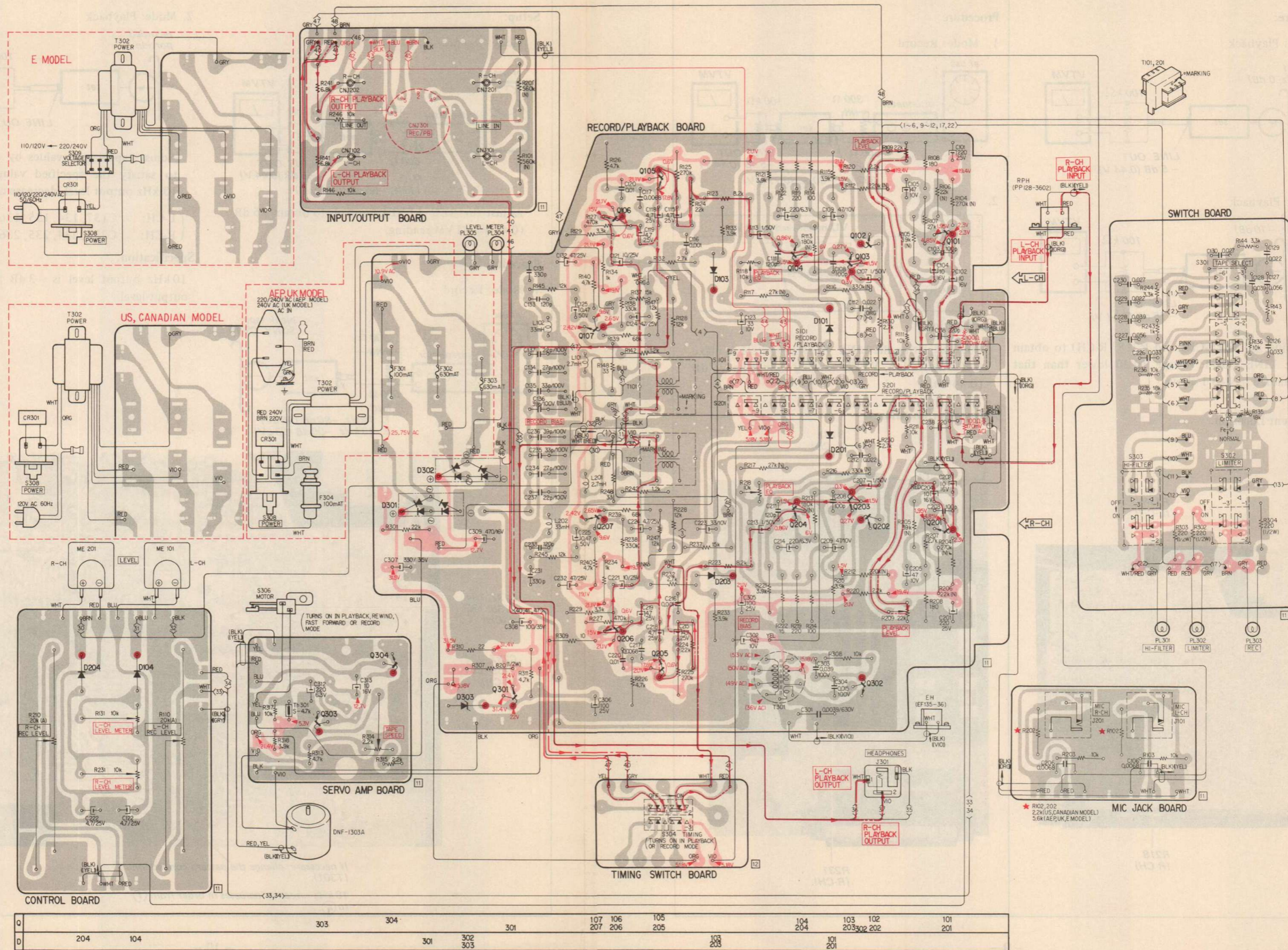

Q101, 201  
Q103, 203: 25C632A

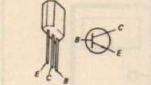

Q102, 202  
Q104 ~ 107: 25C1364  
Q204 ~ 207: 25C1364  
Q302, 303

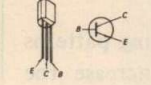

Q301, 304: 25C1475

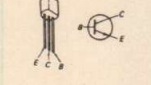

D101, 201: 10D2

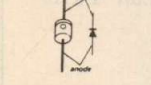

D103, 203  
D104, 204: 1T22A

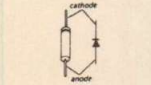

D301, 302: S1R810

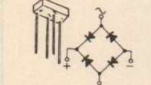

D303: RD22E

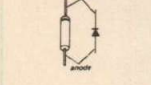

Q		303	304	301	107	106	105	104	103	102	101
D	204	104	301	302	207	206	205	204	203	202	201

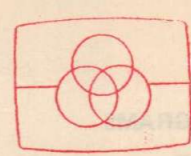

AEP, UK, E, US and Canadian models of former; the former type.

4-2. SCHEMATIC DIAGRAM

Note: The parts printed in RED are for AEP, UK, E model.

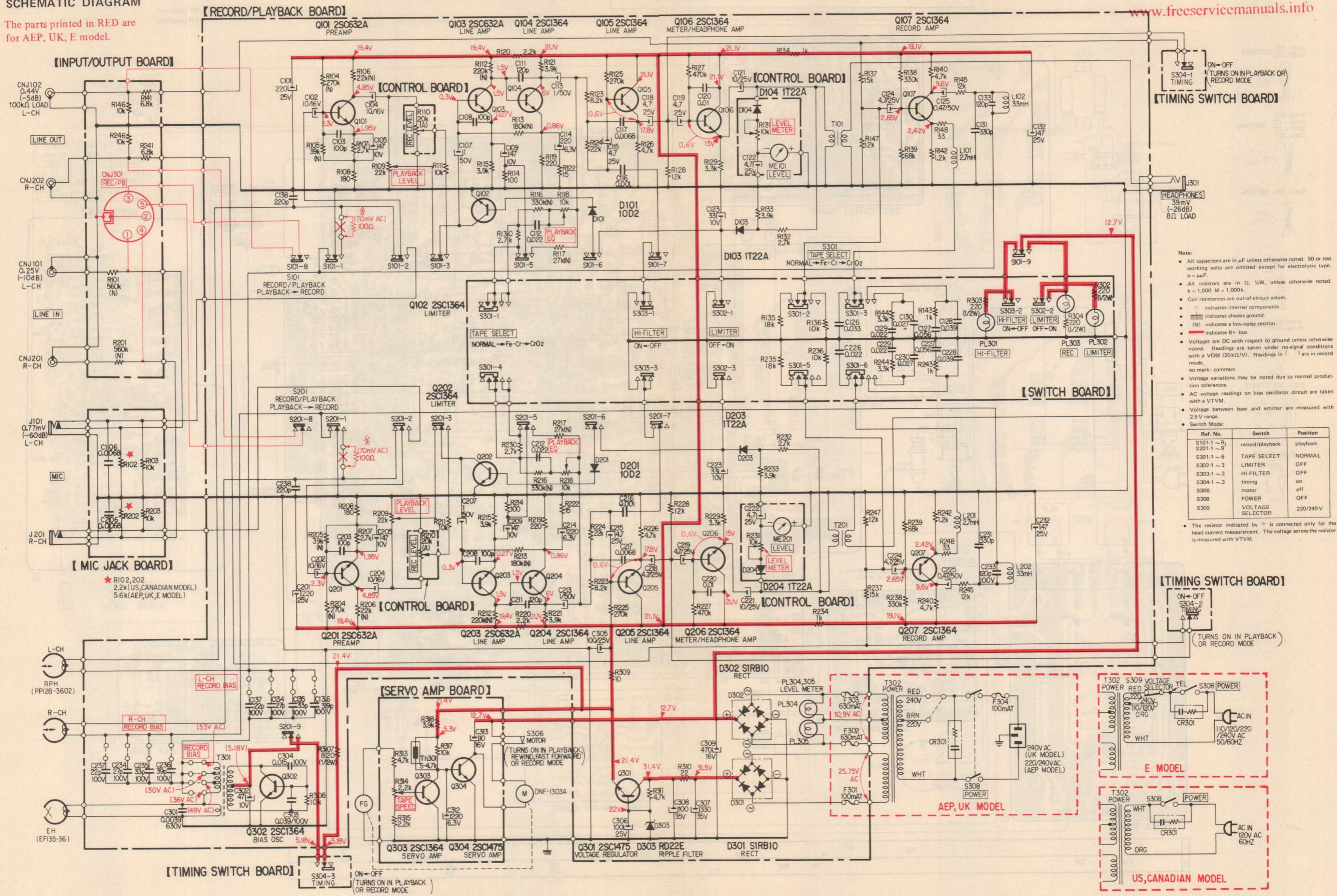

- Note:
- All capacitors are in  $\mu\text{F}$  unless otherwise noted. 50 or less working volts are omitted except for electrolytic type.  $\rho = \mu\text{F}$ .
  - All resistors are in  $\Omega$ ,  $\frac{1}{2}\text{W}$ , unless otherwise noted.  $k = 1,000$   $M = 1,000k$ .
  - Coil resistances are out-of-circuit values.
  - $\Delta$  indicates internal components.
  - $\text{---}$  indicates chassis ground.
  - (N) indicates a low-noise resistor.
  - $\text{---}$  indicates B+ bus.
  - Voltages are DC with respect to ground unless otherwise noted. Readings are taken under no-signal conditions with a VOM (20k $\Omega$ /V). Readings in ( ) are in record mode. no mark: common
  - Voltage variations may be noted due to normal production tolerances.
  - AC voltage readings on bias oscillator circuit are taken with a VTVM.
  - Voltage between base and emitter are measured with 2.5V range.
  - Switch Mode:
- | Ref. No.   | Switch           | Position |
|------------|------------------|----------|
| S101-1 ~ 9 | record/playback  | playback |
| S201-1 ~ 9 | TAPE SELECT      | NORMAL   |
| S302-1 ~ 3 | LIMITER          | OFF      |
| S303-1 ~ 3 | HI-FILTER        | OFF      |
| S304-1 ~ 3 | timing           | on       |
| S306       | motor            | off      |
| S308       | POWER            | OFF      |
| S309       | VOLTAGE SELECTOR | 220/240V |
- The resistor indicated by \* is connected only for the head current measurement. The voltage across the resistor is measured with VTVM.

## 4-3. MOUNTING DIAGRAMS

— Conductor Side —

AEP, UK, E, US and Canadian models of new type, and AUS model.  
The printed pattern on the record/playback and switch boards differs.

Note: The parts printed in-RED are for AEP, UK, E, AUS model.

- Note:
- indicates parts on the conductor side.
  - indicates lead wire connection on the conductor side.
  - indicates lead wire connection through the component side.
  - L-CH signal path
  - R-CH signal path

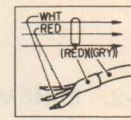

- Q101, 201: 2SC632A
- Q103, 203
- Q102, 202
- Q104 ~ 107: 2SC1364
- Q204 ~ 207: 2SC1364
- Q302, 303
- Q301, 304: 2SC1475
- D101, 201: 10D2
- D103, 203
- D104, 204: 1T22A
- D301, 302: S1RB10
- D303: RD22E

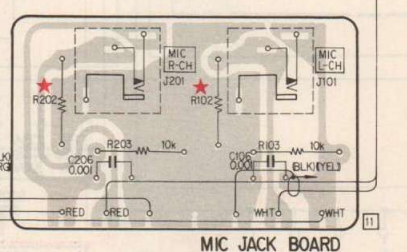
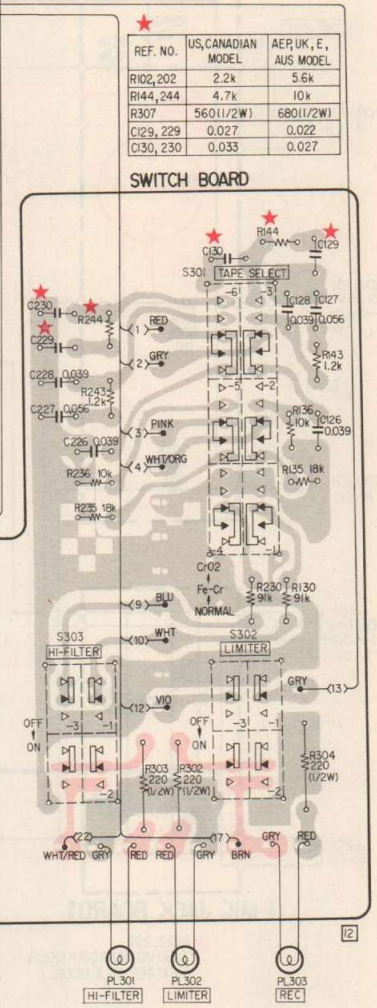
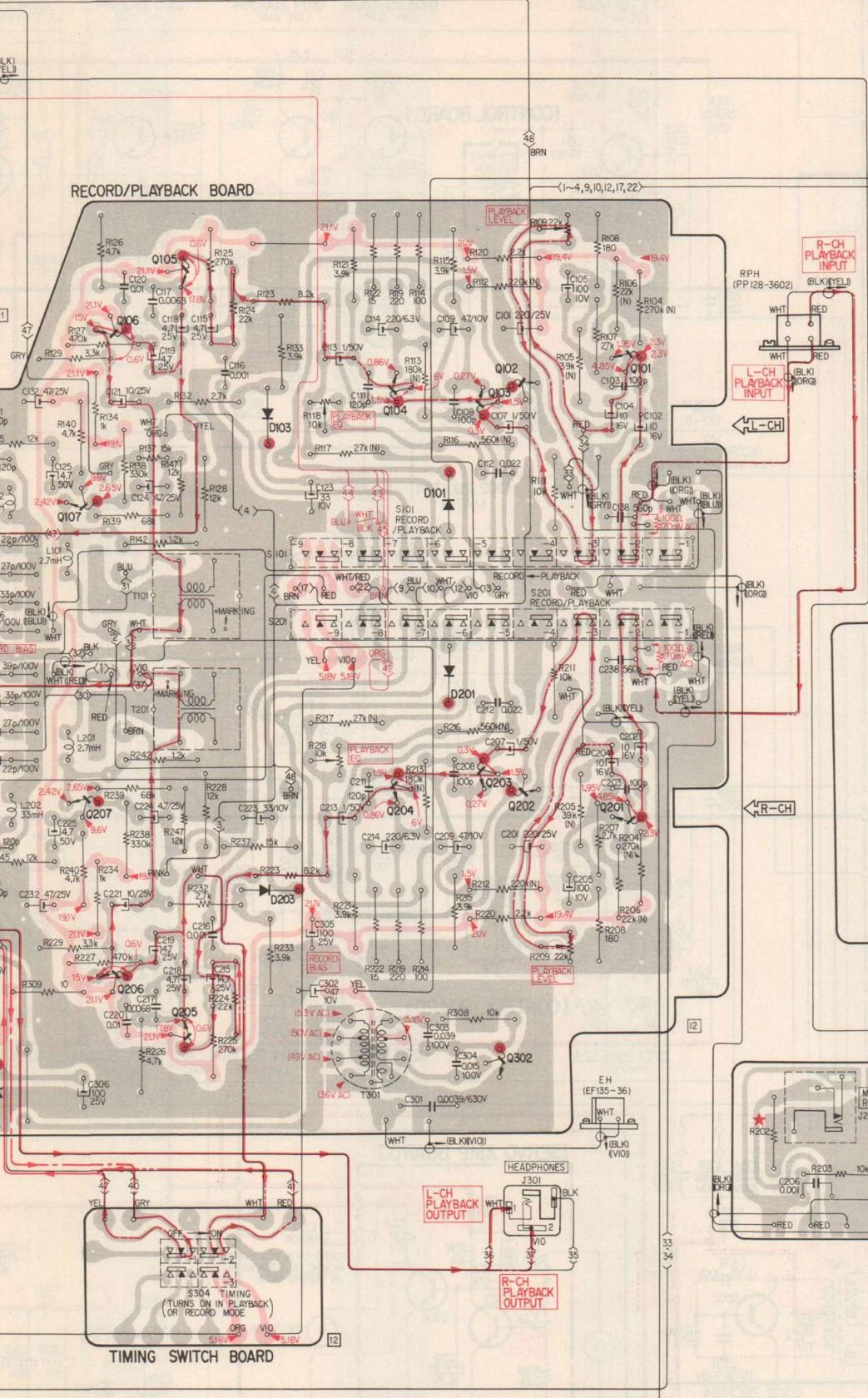
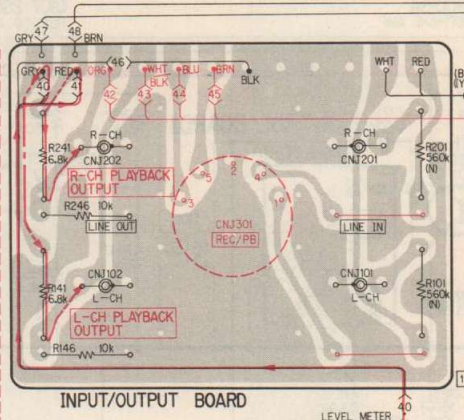
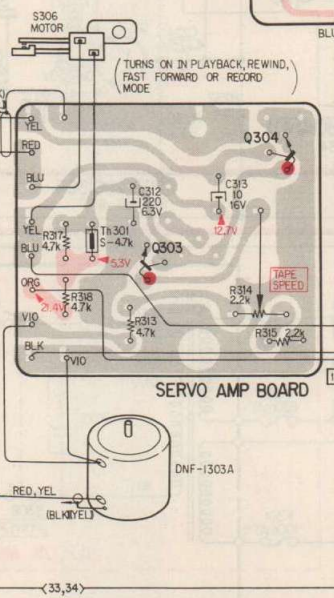
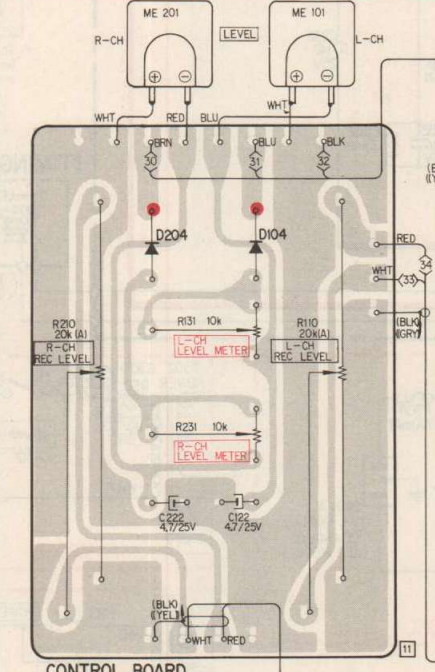
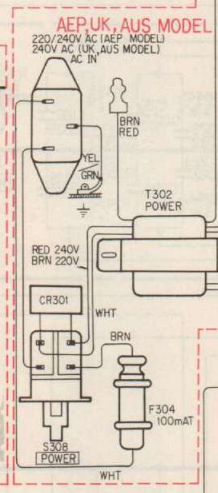
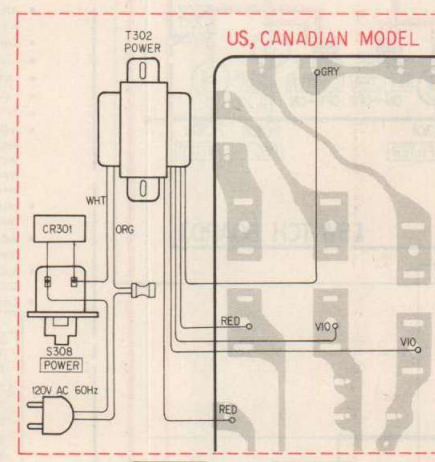
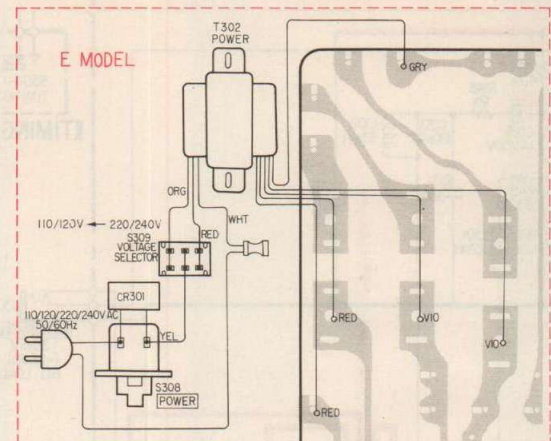

REF. NO.	US, CANADIAN MODEL	AEP, UK, E, AUS MODEL
R102, 202	2.2k	5.6k
R144, 244	4.7k	10k
R307	560(1/2W)	680(1/2W)
C129, 229	0.027	0.022
C130, 230	0.033	0.027

Q	204	104	303	304	107	106	105	104	103	102	101
D					207	206	205	204	203	202	201
					301	302	303	101	201		

AEP, UK, E, US and Canadian models of new type, and AUS model.

4-4. SCHEMATIC DIAGRAM

Note: The parts printed in RED are for AEP, UK, E, AUS model.

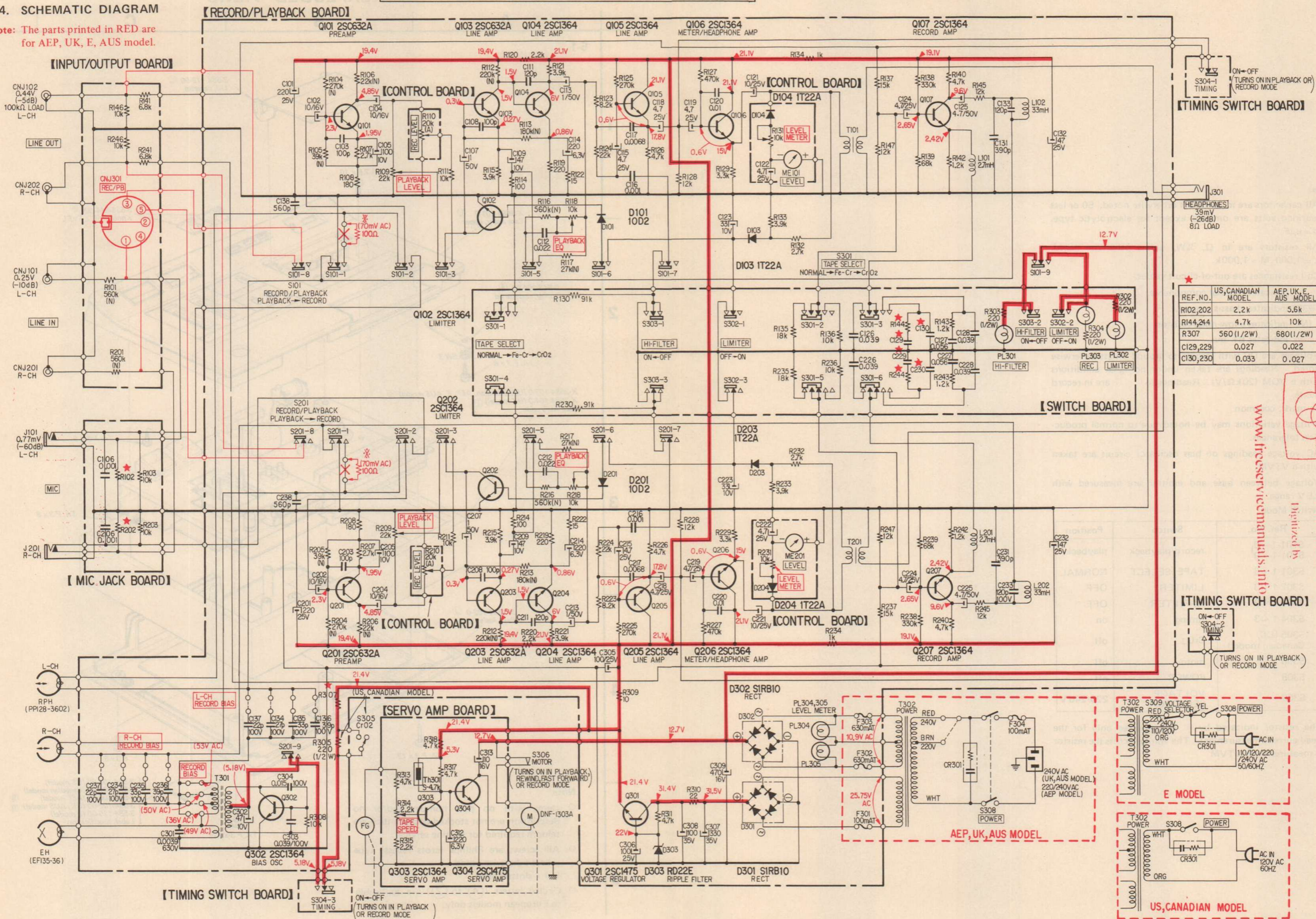

REF. NO.	US, CANADIAN MODEL	AEP, UK, E, AUS MODEL
R102, 202	2.2k	5.6k
R144, 244	4.7k	10k
R307	560 (1/2W)	680 (1/2W)
C129, 229	0.027	0.022
C130, 230	0.033	0.027

www.freeservicemanuals.info

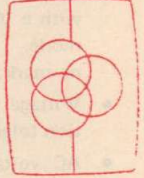

Free service manuals  
Trans schematics  
Digitized by

SECTION 5  
EXPLODED VIEWS

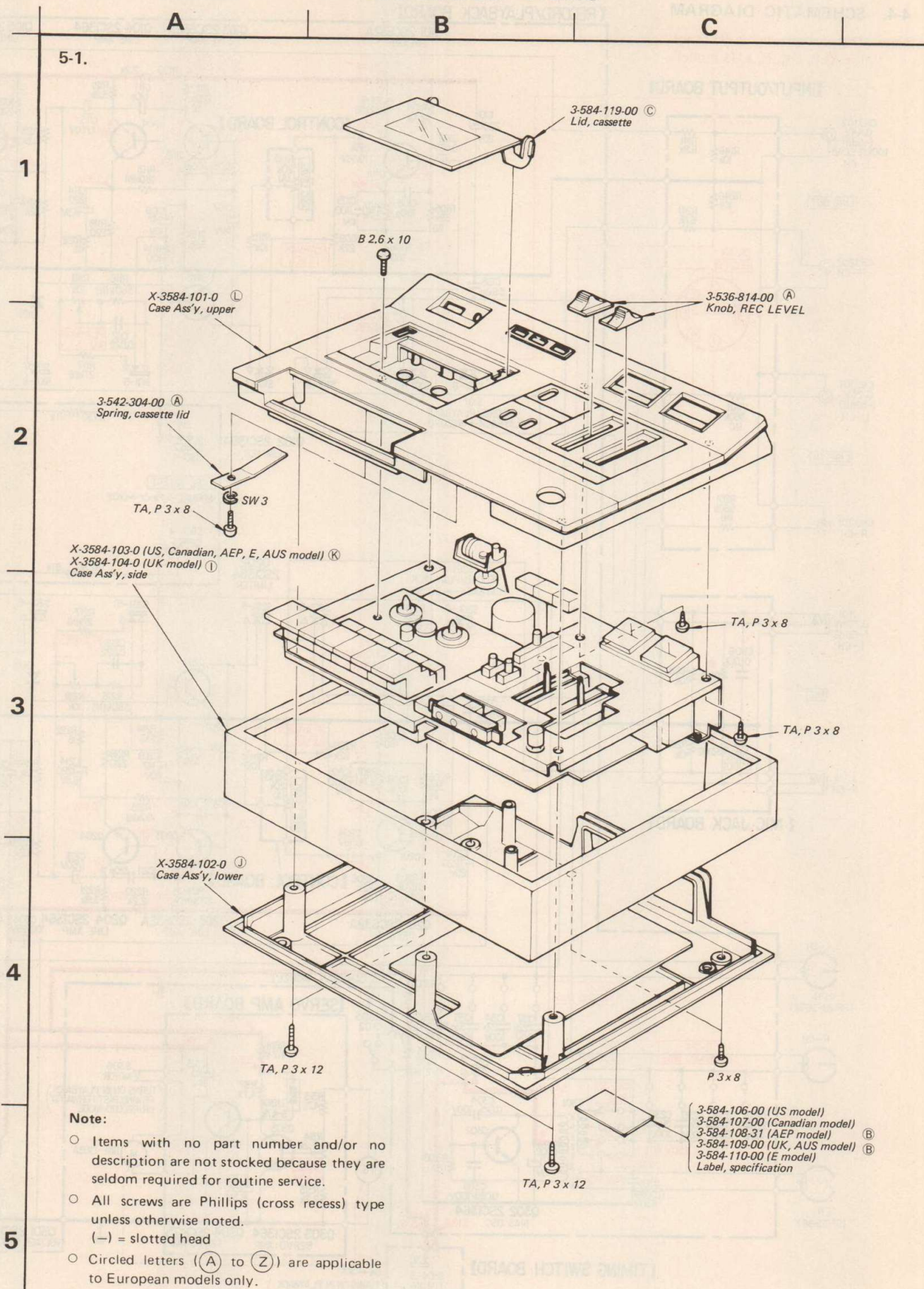

Note:

- All capacitors are in  $\mu\text{F}$  unless otherwise noted. 50 or less working volts are omitted except for electrolytic type.  $\rho = \mu\text{F}$ .
- All resistors are in  $\Omega$ ,  $\frac{1}{4}\text{W}$ , unless otherwise noted.  $k = 1,000$   $M = 1,000k$ .
- Coil resistances are out-of-circuit values.
- $\triangle$  indicates internal components.
- $\text{|||||}$  indicates chassis ground.
- (N) indicates a low-noise resistor.
- — indicates B+ bus.
- Voltages are DC with respect to ground unless otherwise noted. Readings are taken under no-signal conditions with a VOM (20k $\Omega$ /V). Readings in ( ) are in record mode.  
no mark: common
- Voltage variations may be noted due to normal production tolerances.
- AC voltage readings on bias oscillator circuit are taken with a VTVM.
- Voltage between base and emitter are measured with 2.5 V range.
- Switch Mode:

Ref. No.	Switch	Position
S101-1 ~ 9 S201-1 ~ 9	record/playback	playback
S301-1 ~ 6	TAPE SELECT	NORMAL
S302-1 ~ 3	LIMITER	OFF
S303-1 ~ 3	HI-FILTER	OFF
S304-1 ~ 3	timing	on
S305 (US, Canadian model)	CrO <sub>2</sub>	off
S306	motor	off
S308	POWER	off
S309	VOLTAGE SELECTOR	220/240 V

- The resistor indicated by \* is connected only for the head current measurement. The voltage across the resistor is measured with VTVM.

5-2.

1

2

3

4

5

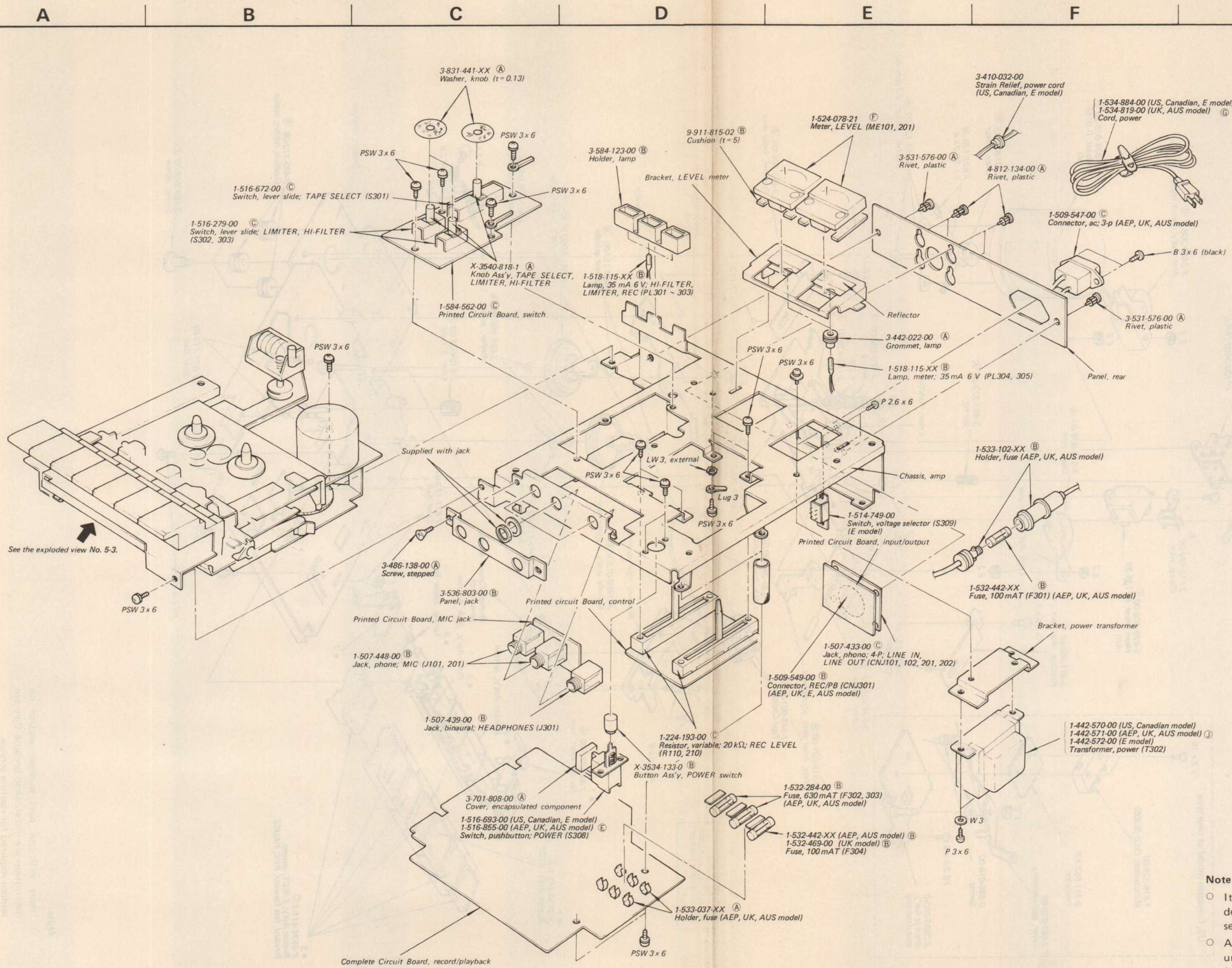

See the exploded view No. 5-3.

- Note:**
- Items with no part number and/or no description are not stocked because they are seldom required for routine service.
  - All screws are Phillips (cross recess) type unless otherwise noted.
  - (-) = slotted head
  - Circled letters (A) to (Z) are applicable to European models only.



SECTION 6

ELECTRICAL PARTS LIST

Note: Circled letters (A) to (Z) are applicable to European models only.

5-4.

Free service manuals  
Gratis schema's  
Digitized by  
www.freesevicemanuals.info

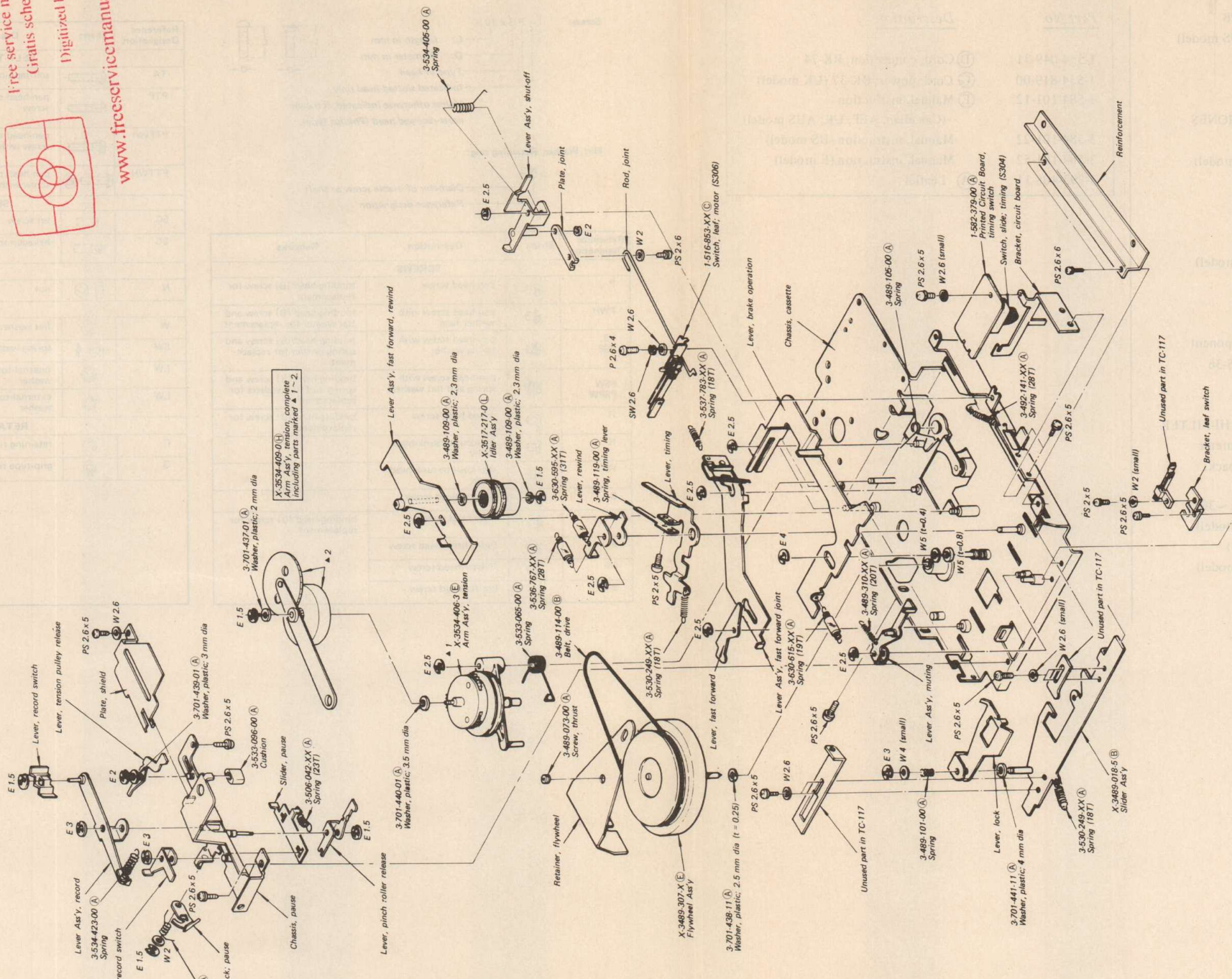
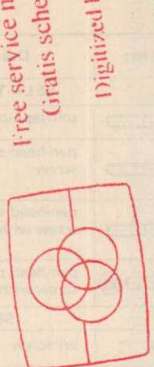

Note:  
○ Items with no part number and/or no description are not stocked because they are seldom required for routine service.  
○ All screws are Phillips (cross recess) type unless otherwise noted.  
○ Circled letters (A) to (Z) are applicable to European models only.

Ref. No. Part No. Description

CIRCUIT BOARDS

- 1-582-379-00 (A) Timing Switch
1-584-562-00 (C) Switch

SEMICONDUCTORS

Transistors

- Q101, 201 (B) 2SC632A
Q102, 202 (B) 2SC1364
Q103, 203 (B) 2SC632A
Q104 ~ 107 (B) 2SC1364
Q204 ~ 207 (B) 2SC1364
Q301 (C) 2SC1475
Q302, 303 (B) 2SC1364
Q304 (C) 2SC1475

Diodes

- D101, 201 (B) 10D2
D103, 203 (B) 1T22A
D104, 204 (B) 1T22A
D301, 302 (C) S1RB10
D303 (C) RD22E

Thermistor

- Th301 1-800-070-XX (A) S-4.7 k

TRANSFORMERS AND COILS

- L101, 201 1-407-196-XX (B) Microinductor, 2.7 mH
L102, 202 1-407-212-XX (A) Microinductor, 33 mH
T101, 201 1-427-284-00 (B) Transformer, output
T301 1-433-132-00 (C) Coil, bias osc
1-442-570-00 Transformer, power (US, Canadian model)
T302 1-442-571-00 (J) Transformer, power (AEP, UK, AUS model)
1-442-572-00 Transformer, power (E model)

Ref. No. Part No. Description

CAPACITORS

All capacitors are in µF and of electrolytic unless otherwise noted. (p = µµF)
50 or less working volts are omitted except for electrolytic type.

- C101, 201 1-121-936-11 (B) 220 25 V
C102, 202 1-121-651-11 (A) 10 16 V
C103, 203 1-102-106-11 (A) 100p ceramic
C104, 204 1-121-651-11 (A) 10 16 V
C105, 205 { 1-121-352-11 (A) 47 10 V (former type)
1-121-414-11 (A) 100 10 V (new type)
C106, 206 { 1-108-555-12 (A) 0.001 mylar (new type)
1-108-575-12 (A) 0.0068 mylar (former type)
C107, 207 1-121-391-11 (A) 1 50 V
C108, 208 1-102-106-11 (A) 100p ceramic
C109, 209 1-121-352-11 (A) 47 10 V
C111, 211 1-102-107-11 (A) 120p ceramic
C112, 212 1-108-587-12 (A) 0.022 mylar
C113, 213 1-121-391-11 (A) 1 50 V
C114, 214 1-121-419-11 (A) 220 6.3 V
C115, 215 1-121-395-11 (A) 4.7 25 V
C116, 216 1-108-555-12 (B) 0.001 mylar
C117, 217 1-108-575-12 (B) 0.0068 mylar
C118, 218 1-121-395-11 (A) 4.7 25 V
C119, 219 1-121-395-11 (A) 4.7 25 V
C120, 220 1-102-129-11 (A) 0.01 ceramic
C121, 221 1-121-398-11 (A) 10 25 V
C122, 222 1-121-395-11 (A) 4.7 25 V
C123, 223 1-121-402-11 (A) 33 10 V
C124, 224 1-121-395-11 (A) 4.7 25 V
C125, 225 { 1-121-396-11 (A) 4.7 50 V (new type)
1-121-726-11 (A) 0.47 50 V (former type)
C126, 226 { 1-108-591-12 (B) 0.033 mylar (former type)
1-108-593-12 (B) 0.039 mylar (new type)
C127, 227 1-108-597-12 (B) 0.056 mylar
C128, 228 1-108-593-12 (B) 0.039 mylar

Note: Circled letters (A) to (Z) are applicable to European models only.

Ref. No.	Part No.	Description
C129, 229	1-108-587-12 (A) 0.022	mylar (former type, AEP, UK, E model of new type and AUS model)
	1-108-589-12	0.027 mylar (US, Canadian model of new type)
C130, 230	1-108-589-12 (A) 0.027	mylar (former type, AEP, UK, E model of new type and AUS model)
	1-108-591-12	0.033 mylar (US, Canadian model of new type)
C131, 231	1-102-112-11 (A) 330p	ceramic (former type)
	1-102-113-11 (A) 390p	ceramic (new type)
C132, 232	1-121-410-11 (B) 47	25 V
C133, 233	1-107-133-11 (A) 120p	100 V silvered mica
⇒C134, 234	1-107-157-11 (A) 27p	500 V silvered mica
⇒C135, 235	1-107-054-11 (A) 33p	500 V silvered mica
⇒C136, 236	1-107-055-11 (A) 39p	500 V silvered mica
⇒C137, 237	1-107-210-11 (A) 22p	500 V silvered mica
C138, 238	1-102-110-11 (A) 220p	ceramic (former type)
	1-102-115-11 (A) 560p	ceramic (new type)
C301	1-127-709-11 (B) 0.0039	630 V polypropylene
C302	1-121-352-11 (A) 47	10 V
C303	1-108-384-12 (B) 0.039	100 V mylar
C304	1-108-379-12 (A) 0.015	100 V mylar
C305, 306	1-121-416-11 (A) 100	25 V
C307	1-121-655-11 (B) 330	35 V
C308	1-121-357-11 (B) 100	35 V
C309	1-121-426-11 (B) 470	16 V
C312	1-121-419-11 (A) 220	6.3 V
C313	1-121-654-11 (B) 10	16 V

**RESISTORS**

All resistors are in ohms. Regular-type 1/4 W carbon resistors are omitted. Check schematic diagram for resistance values. k = 1,000

R109, 209	1-224-253-XX (C) 22 k	adjustable
-----------	-----------------------	------------

Note: ⇒: Due to replacement parts, the values are different on the diagrams.

Ref. No.	Part No.	Description
R110, 210	1-224-193-00 (C) 20 k	variable, REC LEVEL
R118, 218	1-224-252-XX (C) 10 k	adjustable
R131, 231	1-224-252-XX (C) 10 k	adjustable
R302 ~ 304	1-202-557-31 (A) 220	1/2 W composition
R305	1-202-557-31	220 1/2 W composition (US, Canadian model of new type)
R307	1-202-567-31	560 1/2 W composition (US, Canadian model of new type)
	1-202-569-31 (A) 680	1/2 W composition (AEP, UK, E model of new type and AUS model)
	1-202-571-31 (A) 820	1/2 W composition (former type)
R314	1-224-643-XX (B) 2.2 k	adjustable

**SWITCHES**

S101, 201	1-514-976-XX (C)	Slide, record/playback select
S301	1-516-672-00 (C)	Lever Slide, TAPE SELECT
S302, 303	1-516-279-00 (C)	Lever Slide, LIMITER, HI-FILTER
S304	1-513-273-00 (B)	Slide, timing
S305	1-516-325-00	Micro, CrO2 (US, Canadian model of new type)
S306	1-516-853-XX (C)	Leaf, motor
S308	1-516-693-00	Pushbutton, POWER (US, Canadian, E model)
	1-516-855-00 (E)	Pushbutton, POWER (AEP, UK, AUS model)
S309	1-514-749-00	Voltage Selector (E model)

**FUSES**

F301	1-532-442-XX (B)	100 mA (AEP, UK, AUS model)
F302, 303	1-532-284-00 (B)	630 mA (AEP, UK, AUS model)
F304	1-532-442-XX (B)	100 mA (AEP, AUS model)
	1-532-469-00 (B)	100 mA (UK model)

**JACKS**

CNJ101, 201	1-507-433-00 (C)	Phono, 4-p: LINE IN, LINE OUT
CNJ102, 202		

Ref. No.	Part No.	Description
CNJ301	1-509-549-00 (B)	Connector, REC/PB (AEP, UK, E, AUS model)
J101, 201	1-507-448-00 (B)	Phone, MIC
J301	1-507-439-00 (B)	Binaural, HEADPHONES
	1-509-547-00 (C)	Connector, ac; 3-p (AEP, UK, AUS model)

**POWER CORDS**

1-534-819-00 (G)	(UK, AUS model)
1-534-884-00	(US, Canadian, E model)

**MISCELLANEOUS**

CR301	1-231-057-31 (B)	Encapsulated Component
EH	8-825-506-00 (D)	Head, erase; EF 135-36
M	8-834-015-50 (K)	Motor, D-015F
ME101, 201	1-524-078-21 (E)	Meter, LEVEL
PL301 ~ 305	1-518-115-XX (B)	Lamp, 35 mA 6 V, HI-FILTER, LIMITER, REC, meter
RPH	8-829-236-20 (K)	Head, record/playback; PP128-3602
	1-533-037-XX (A)	Holder, fuse (F302 ~ 304) (AEP, UK, AUS model)
	1-533-102-XX (B)	Holder, fuse (F301) (AEP, UK, AUS model)
	1-548-501-31 (E)	Counter, tape

Note: Circled letters (A) to (Z) are applicable to European models only.

**ACCESSORIES**

Part No.	Description
1-534-049-31	(D) Cord, connection; RK-74
1-534-819-00	(C) Cord, power; DK-37 (UK model)
3-584-101-12	(E) Manual, instruction (Canadian, AEP, UK, AUS model)
3-584-101-22	Manual, instruction (US model)
3-584-101-52	Manual, instruction (E model)
3-793-408-11	(A) Leaflet

**HARDWARE NOMENCLATURE**

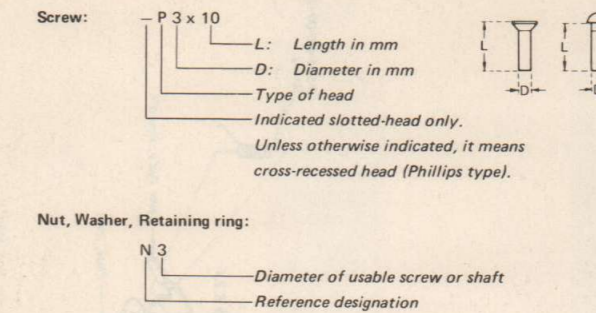

Reference Designation	Shape	Description	Remarks
<b>SCREWS</b>			
P		pan-head screw	binding-head (B) screw for replacement
PWH		pan-head screw with washer face	binding-head (B) screw and flat washer for replacement
PS		pan-head screw with spring washer	binding-head (B) screw and spring washer for replacement
PSP		pan-head screw with spring washer	binding-head (B) screw and spring washer for replacement
PSW		pan-head screw with spring and flat washers	binding-head (B) screw and spring and flat washers for replacement
PSPW		pan-head screw with spring and flat washers	binding-head (B) screw and spring and flat washers for replacement
R		round-head screw	binding-head (B) screw for replacement
K		flat-countersunk-head screw	
RK		oval-countersunk-head screw	
B		binding-head screw	
T		truss-head screw	binding-head (B) screw for replacement
F		flat-fillister-head screw	
RF		fillister-head screw	
BV		braizer-head screw	

Reference Designation	Shape	Description	Remarks
<b>SELF-TAPPING SCREWS</b>			
TA		self-tapping screw	ex: TA, P 3 x 10
PTP		pan-head self-tapping screw	binding-head self-tapping (TA, B) screw for replacement
PTPWH		pan-head self-tapping screw with washer face	binding-head self-tapping (TA, B) screw and flat washer for replacement
PTTWH		pan-head thread-rolling screw with washer face	binding-head (B) screw and flat washer for replacement
<b>SET SCREWS</b>			
SC		set screw	
SC		hexagon-socket set screw	ex: SC 2.6 x 4, hexagon socket
<b>NUT</b>			
N		nut	
<b>WASHERS</b>			
W		flat washer	
SW		spring washer	
LW		internal-tooth lock washer	ex: LW3, internal
LW		external-tooth lock washer	ex: LW3, external
<b>RETAINING RINGS</b>			
E		retaining ring	
G		grip-type retaining ring	