

TAE-8450

USA Model
AEP Model



STEREO PREAMPLIFIER

SPECIFICATIONS

Peak Program Meter (at PEAK mode)

Frequency response: 30 Hz ~ 30,000 Hz ± 0 dB
Response range: -50 dB ~ +5 dB (0 dB = 1 V rms), With the METER SENS switch pulled . . . -30 dB ~ +25 dB
Response time: 1 millisecond at PEAK mode

Power requirements: 120 V ac, 50/60 Hz (USA Model)
100, 120, 220, 240 V ac, 50/60 Hz (AEP Model)

Power consumption: 20 W (USA Model)
22 W (AEP Model)

Ac outlets: 2 switched 400 watts, 1 unswitched 400 watts

Dimensions: 440 (w) x 170 (h) x 340 (d) mm
17 $\frac{3}{8}$ (w) x 6 $\frac{3}{4}$ (h) x 13 $\frac{3}{8}$ (d) inches

Weight: 11.8 kg (26 lb), net
14.2 kg (31 lb 5 oz), in shipping carton

Harmonic distortion: Less than 0.03% at rated output, 1 kHz

IM distortion: Less than 0.05% at rated output
(60 Hz : 7 kHz = 4 : 1)

Frequency response: PHONO 1, 2 RIAA equalization curve ± 0.2 dB
MIC 20 Hz ~ 20,000 Hz ± 0 dB
TUNER 10 Hz ~ 100,000 Hz ± 0 dB
AUX1, 2, 3 ± 1 dB
TAPE 1, 2
EXT ADPT

Tone controls: (11 steps, each 2 dB)
BASS ± 10 dB at 50 Hz (TURNOVER FREQUENCY 250 Hz)
 ± 10 dB at 100 Hz (TURNOVER FREQUENCY 500 Hz)
TREBLE ± 10 dB at 10 kHz (TURNOVER FREQUENCY 2.5 kHz)
 ± 10 dB at 20 kHz (TURNOVER FREQUENCY 5 kHz)

Filters: LOW 12 dB/octave below 10 Hz or 40 Hz
HIGH 12 dB/octave above 9 kHz or 20 kHz

Presence control: + 3.5 dB at 1 kHz

Residual noise: Less than 70 μ V (with VOLUME set fully counterclockwise, TONE to mechanical-mid position, FILTERs to OFF, PRESENCE to OFF)

SONY
SERVICE MANUAL

TAE-8450

— Continued from page 1 —

Inputs:

	Sensitivity*	Impedance	Maximum Input Capability (THD 0.1%)	S/N (weighting network, input level)
PHONO 1	1.5 mV	50 k Ω	140 mV	70 dB
PHONO 2	4.5 mV	50 k Ω /100 k Ω	400 mV	(A, 1.5 mV)
(HEAD AMP)	0.16 mV	10 Ω , 30 Ω , 100 Ω , 1 k Ω	13 mV	60 dB (A, 0.16 mV)
MIC	0.16 mV	50 k Ω	1.2 V	50 dB (B, 0.16 mV)
TUNER				
AUX 1, 2, 3	150 mV	50 k Ω	—	90 dB (A, 150 mV)
TAPE 1, 2				
EXT ADPT				

* The sensitivities of TUNER, AUX 1, AUX 2, TAPE 1, TAPE 2 and MIC are adjustable.

Outputs:

	Output Level	Impedance
REC OUT 1, 2	150 mV (max. 14 V)	1 k Ω
HEADPHONE	0.5 V (8 Ω headphone) 6.0 V (10 k Ω headphone)	100 Ω
OUTPUT 1, 2	1 V (max. 14 V)	1 k Ω
EXT ADPT	150 mV	10 k Ω

Voltage amplification: (at 1 kHz)

INPUTS \ OUTPUTS	REC OUT 1, 2	HEADPHONE	EXT ADPT (OUTPUT)	OUTPUT 1, 2
PHONO 1 (1.5 mV)	40 dB	51 dB	40 dB	58 dB
PHONO 2 (1.5 mV)				
HEAD AMP	60 dB	71 dB	60 dB	78 dB
MIC	58 dB	69 dB	58 dB	76 dB
TUNER				
AUX 1, 2, 3	0 dB	11 dB	0 dB	18 dB
TAPE 1, 2				
EXT ADPT (INPUT)				

IDENTIFICATION OF SET

Identify TAE-8450 model by checking the specification label shown below.

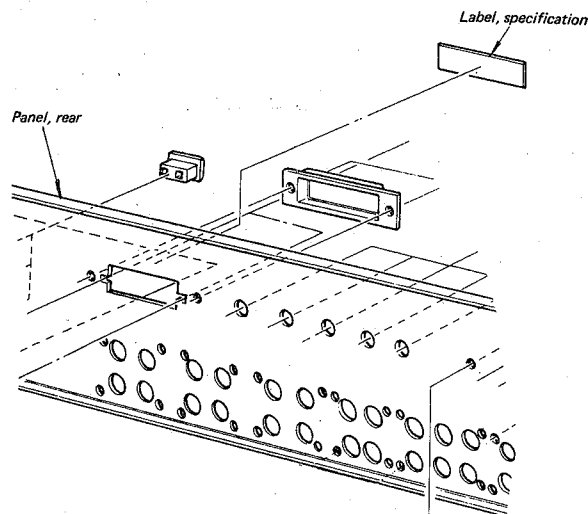

SPECIFICATION LABEL

(USA Model)

SONY [®] 4-836-102-01	STEREO PREAMPLIFIER
	MODEL NO. TAE-8450
	AC 120 V 60 Hz 20 W
	SERIAL NO. XXXXXXXXXX
	MADE IN JAPAN

(AEP Model)

SONY [®] 4-836-151-01	STEREO PREAMPLIFIER
	MODEL NO. TAE-8450
	AC 100, 120, 220, 240 V 50/60 Hz 22 W
	SERIAL NO. _____
	MADE IN JAPAN

SECTION 2

DISASSEMBLY AND REPLACEMENT

Note: All screws in this service manual are Phillips type (cross recess type), unless otherwise indicated.

2-1. FRONT PANEL REMOVAL

1. Remove the top cover and the two side boards.
2. Remove the VOLUME control knob by loosening the set screw.
3. Remove the five screws shown in Fig. 2-1 and Fig. 2-2.

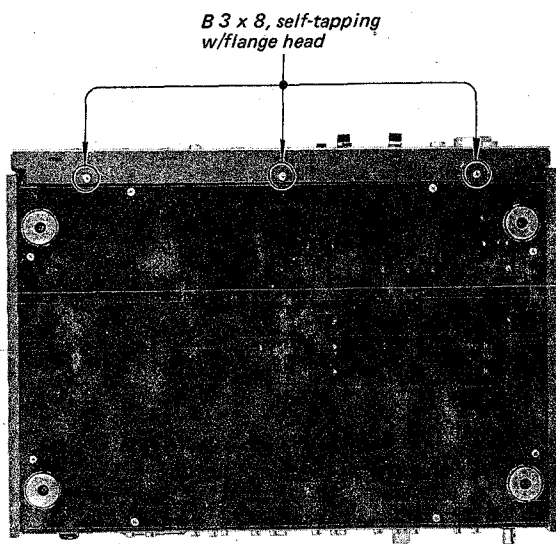

Fig. 2-1. Front panel removal

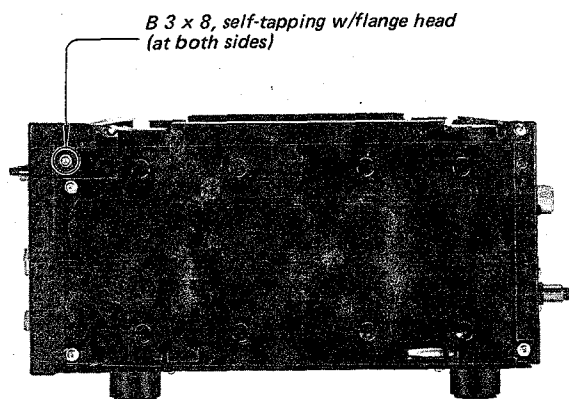

Fig. 2-2. Front panel removal

2-2. POWER SWITCH AND VOLUME CONTROL KNOB REMOVAL

1. The POWER switch knob can be removed by pulling it straight out, after removing the front panel.
2. The VOLUME control knob can be removed by loosening the set screw.

Note: All knobs except for the POWER switch and the VOLUME control knobs can be removed by pulling them straight out.

2-3. FRONT SUBCHASSIS REMOVAL

1. Remove the front panel as described in Procedure 2-1.
2. Loosen the two set screws shown in Fig. 2-3.
3. Unplug the 6-P connector from the I circuit board.
4. Remove the six screws shown in Fig. 2-4 and Fig. 2-5. This frees the front subchassis.

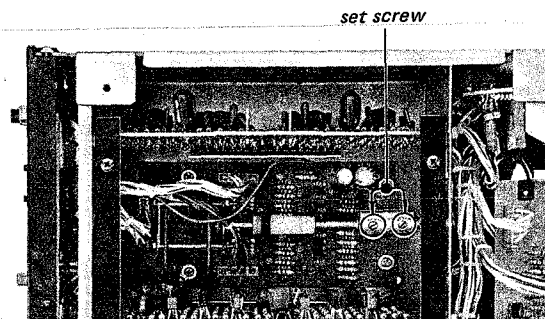

Fig. 2-3. Front subchassis removal

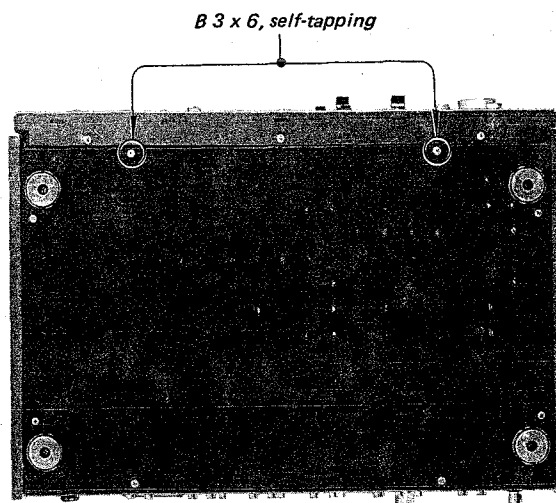

Fig. 2-4. Front subchassis removal

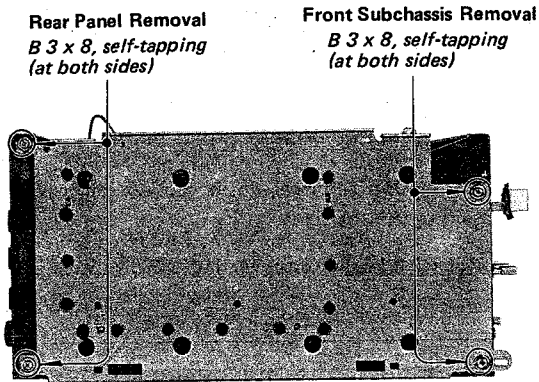

Fig. 2-5. Front subchassis and rear panel removal

2.4. REAR PANEL REMOVAL

1. Remove the top cover and the two side boards.
2. Remove the six screws shown in Fig. 2-5 and Fig. 2-6.
This frees the rear panel.

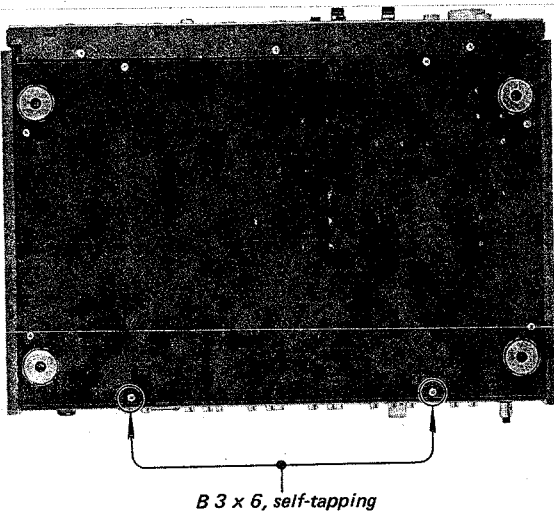

Fig. 2-6. Rear panel removal

2.5. CIRCUIT BOARD REMOVAL

Note: The names of all the circuit boards are replaced by alphabetical reference designation as follows:

Ref. Designation	Circuit-Board
A	Volume Control
B	Selector Switch
C	Tone Control
D	Filter
E	MIC/AUX
F	Equalizer
G	Phono Head Amp
H	Tone Control Amp
I	Peak Program Meter
J	MIC/Headphone Amp
K	Phono Jack
L	Power Supply

A, B, C, D, E Circuit Boards

1. Remove the front subchassis as described in Procedure 2-3.
2. Remove the peak program meter.
3. Remove the screws shown in Fig. 2-7.
This frees the circuit boards.

Note: Be careful to the direction of the connector as shown in Fig. 2-8, when replugging the connector.

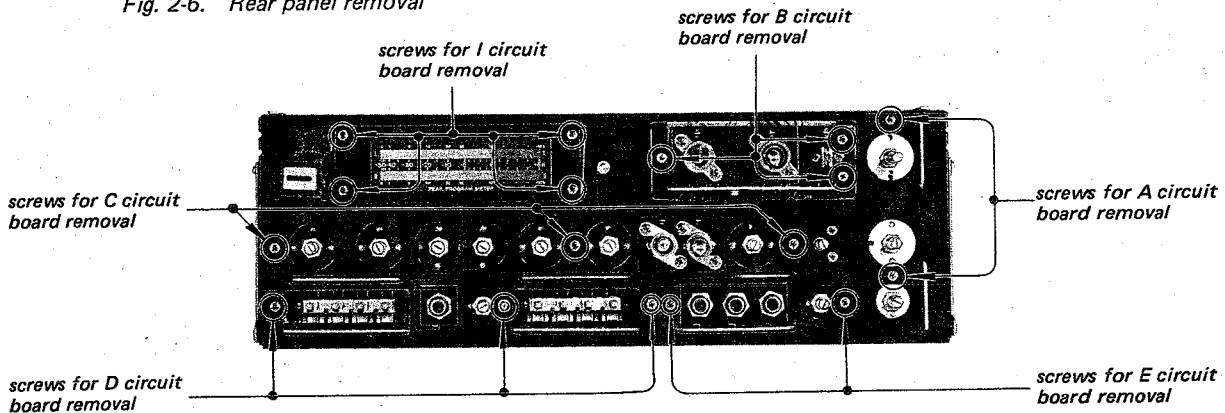

Fig. 2-7. Circuit board removal

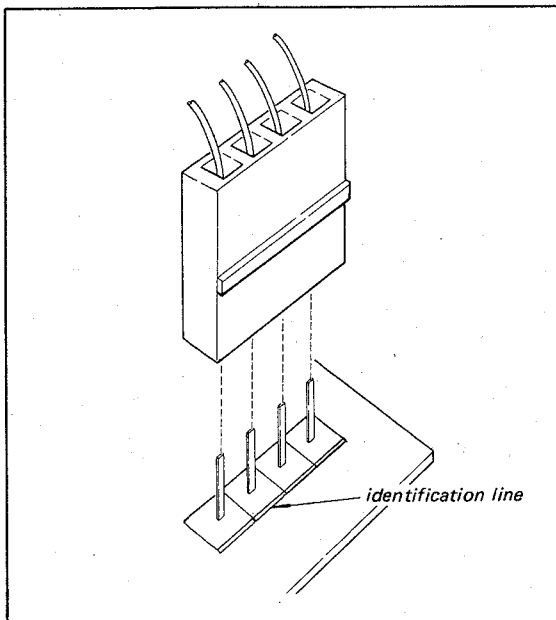

Fig. 2-8. Connector installation

G Circuit Board

Remove the bottom plate, and you can check the G circuit board.

F, H, I, J Circuit Boards (See Fig. 2-7)

1. Remove the four screws (marked ★) shown in Fig. 2-9.
2. Pull the circuit board straight off taking care not to break the circuit board.

K Circuit Board

1. Remove the two screws and the six nuts shown in Fig. 2-10.
2. Remove the rear panel as described in Procedure 2-4.
3. Remove the nylon rivets securing the phono jacks to the rear panel. To remove the nylon rivet, push its end as far as it goes.

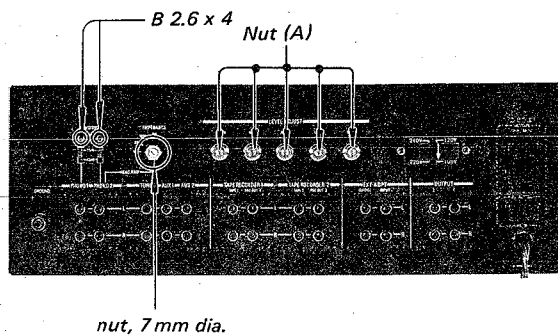

Fig. 2-10. K circuit board removal

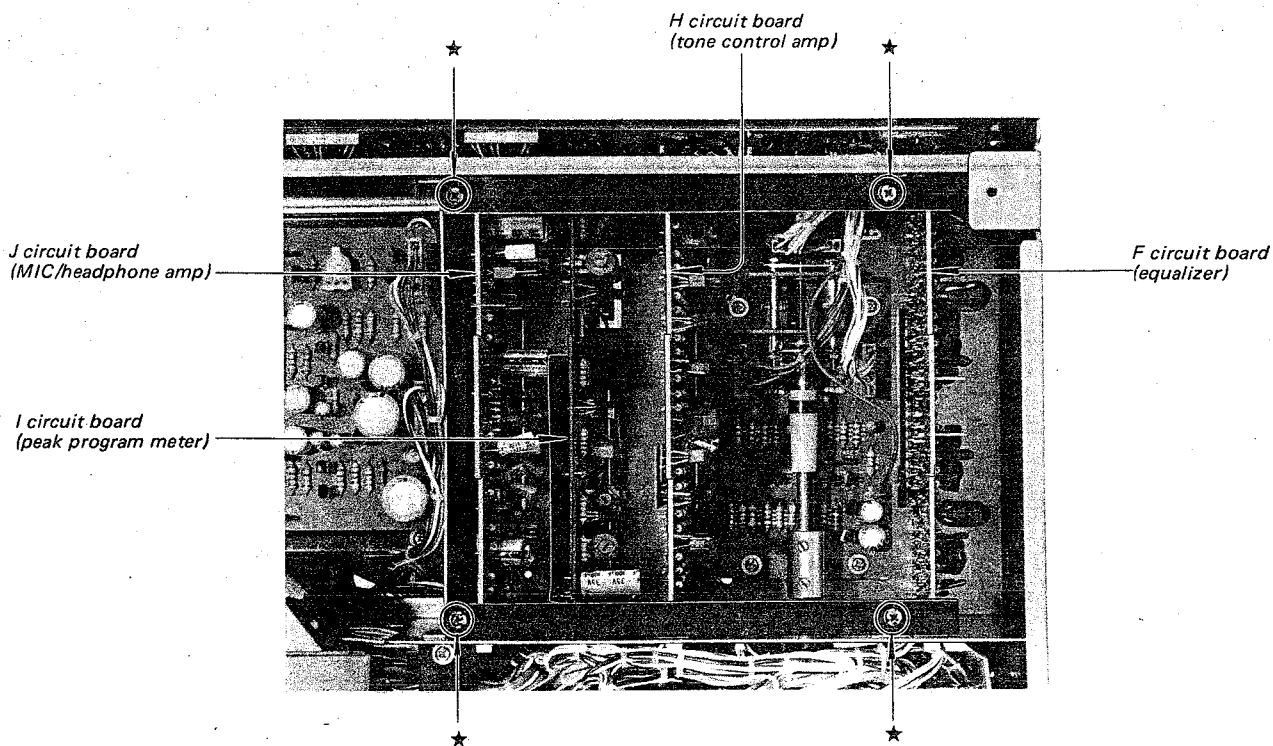

Fig. 2-9. Circuit board removal

2.6. CHASSIS LAYOUT

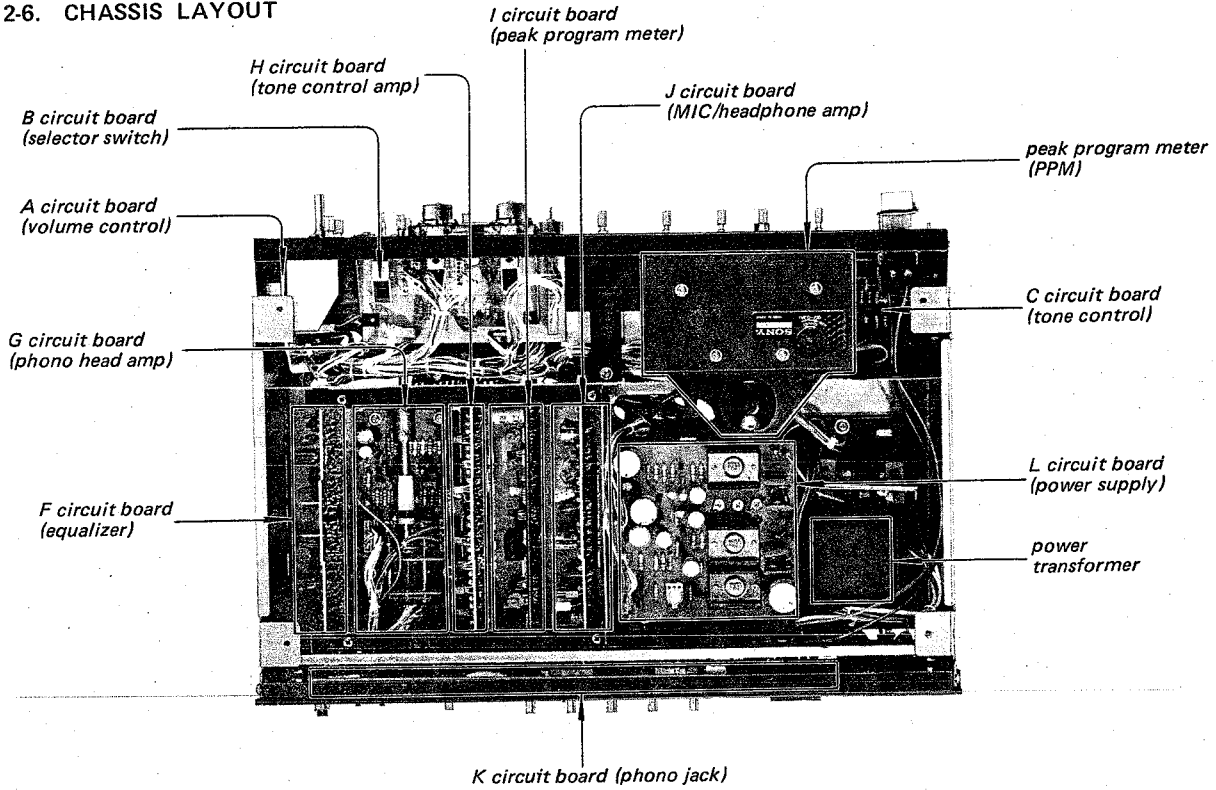

Fig. 2-11. Chassis top view

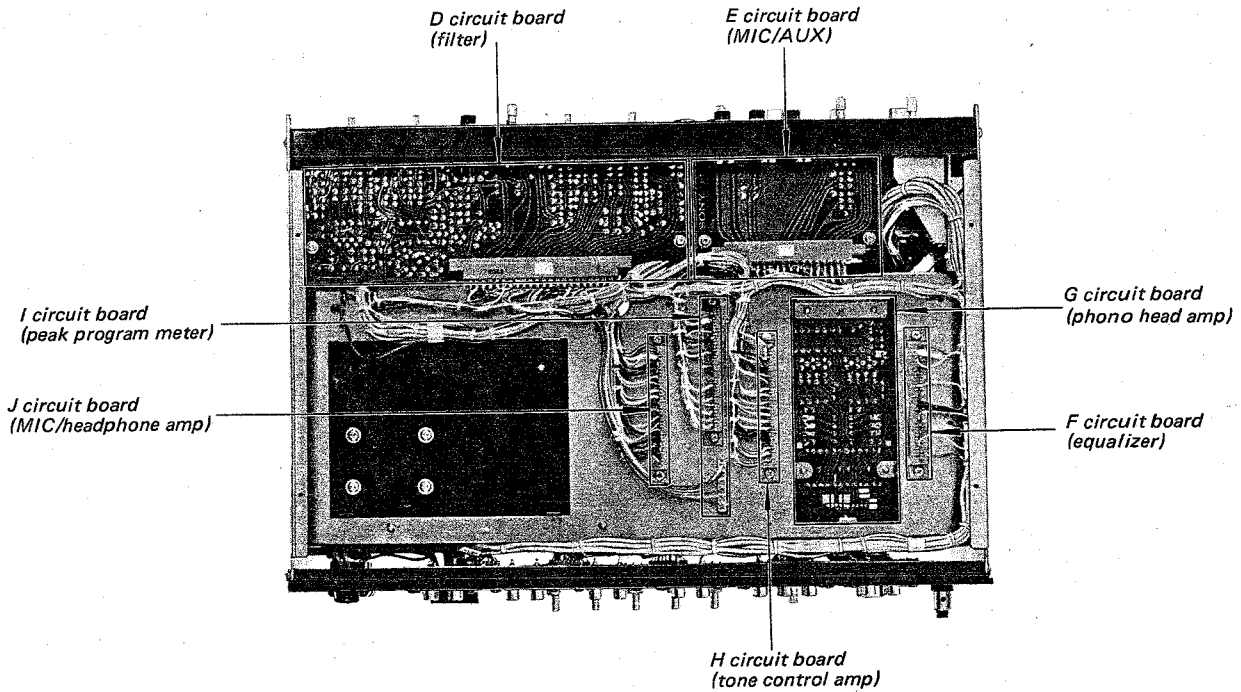

Fig. 2-12. Chassis bottom view

SECTION 3 ADJUSTMENTS

Note: Before starting the adjustments or checks, set the controls and the switches as follows, unless otherwise noted.

FUNCTION switch TUNER
 MONITOR switch SOURCE
 MODE switch L + R
 VOLUME control fully clockwise
 BALANCE and TONE controls mechanical mid
 Other controls and switches Not specially specified

3-1. POWER VOLTAGE CHECK

(See Fig. 3-1.)

Confirm that the specified power voltage is obtained.

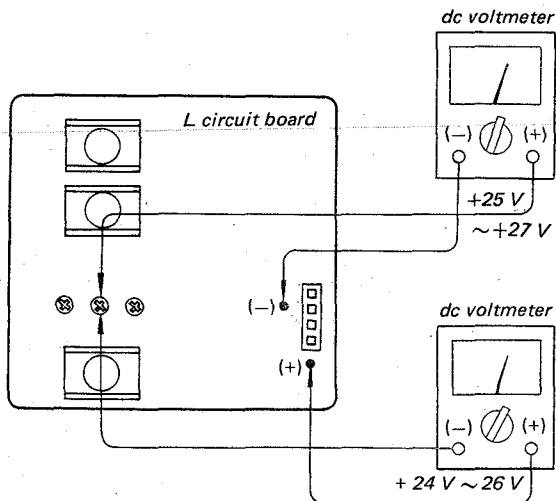

Fig. 3-1. Power voltage check

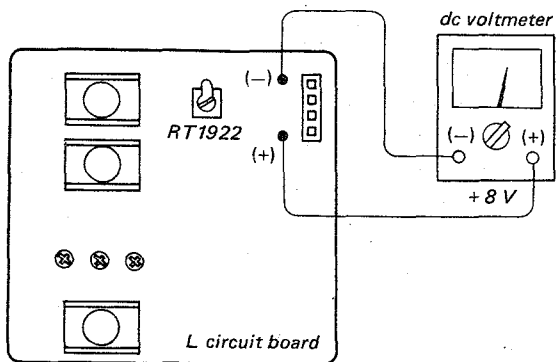

Fig. 3-2. Lamp voltage adjustment

3-2. LAMP VOLTAGE ADJUSTMENT

(See Fig. 3-2.)

Adjust RT1922 for +8 V reading on the dc voltmeter.

3-3. EQUALIZER ADJUSTMENT

(See Fig. 3-3.)

Adjust RT301 (L-CH), RT401 (R-CH) for 0 V reading on the dc voltmeter with no input signal.

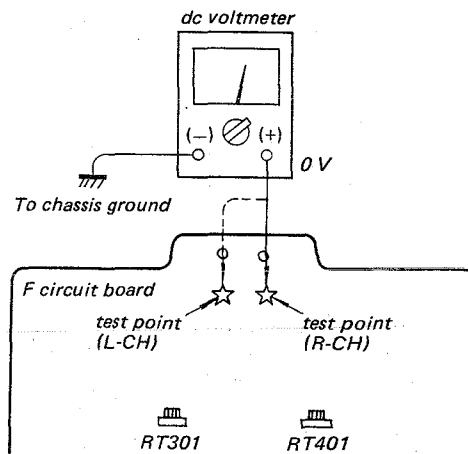

Fig. 3-3. Equalizer adjustment

3-4. PRESENCE SWITCH CHECK

1. Set the PRESENCE switch to OFF.
2. Connect the equipment as shown in Fig. 3-4.
3. Feed a 1 kHz signal to TUNER INPUT jack, and adjust the attenuator for 0 dB reading on the VTVM.
4. Change the PRESENCE switch to ON, and confirm that the VTVM reads $+3.5 \pm 1$ dB.

3-5. PHONO SENSITIVITY CHECK

1. Connect the equipment as shown in Fig. 3-4.
2. Set the PHONO FUNCTION switch to PHONO-1.
3. Set the SENSITIVITY switch to 1.5 mV.
4. Feed a 1 kHz signal to PHONO-1 INPUT jack, and adjust the attenuator for 0 dB reading on the meter.

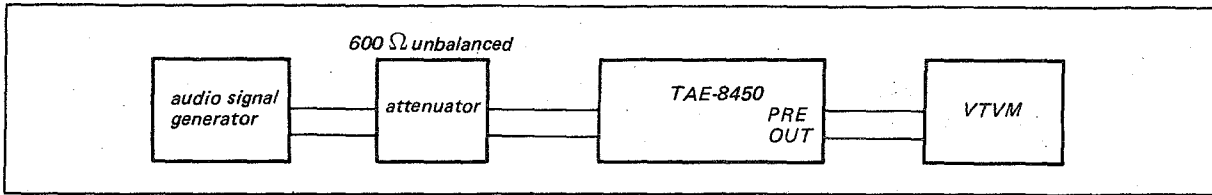

Fig. 3-4. Presence switch check/phono sensitivity check/peak program meter adjustment setup

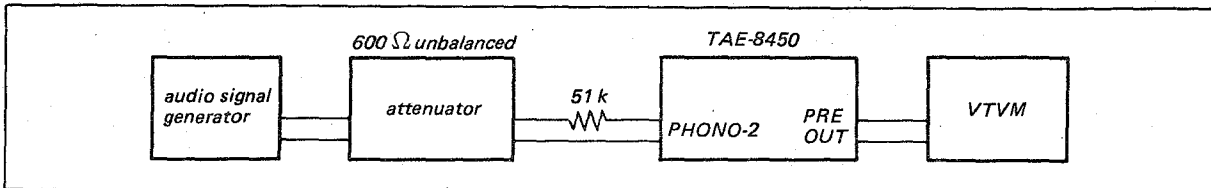

Fig. 3-5. Pre-out check setup

5. Change the SENSITIVITY switch to 4.5 mV, and confirm that the VTVM reads -10 ± 1 dB.
6. Change the PHONO FUNCTION switch to PHONO-2, and repeat above steps 3 to 5.

Note: Feed a 1 kHz signal to PHONO-2 INPUT jack for step 6.

3-6. PRE-OUT CHECK

1. Connect the equipment as shown in Fig. 3-5.
2. Set the PHONO FUNCTION switch to PHONO 2 - 50 kΩ, and the SENSITIVITY switch to 1.5 mV.
3. Feed a 1 kHz signal to PHONO-2 INPUT jack, and adjust the attenuator for 0 dB reading on the VTVM.
4. Change the PHONO FUNCTION switch to PHONO 2 - 100 kΩ.
5. Confirm that the VTVM reads $+4.0 \pm 1$ dB.
6. Change the PHONO FUNCTION switch to PHONO 2-HEAD AMP.
7. Set the IMPEDANCE switch to 1 kΩ.
8. Feed a 1 kHz signal to PHONO-2 INPUT jack, and adjust the attenuator for 0 dB reading on the VTVM.

9. When the IMPEDANCE switch is changed to 100 Ω, 30 Ω, 10 Ω, confirm that the VTVM reads as follows.

IMPEDANCE Switch Position	PRE OUT
1 kΩ	0 dB
100 Ω	-12.5 ± 1 dB
30 Ω	-17.0 ± 1 dB
10 Ω	-26.0 ± 1 dB

3-7. PEAK PROGRAM METER ADJUSTMENT

1. Set the METER FUNCTION switches to PEAK and PRE OUT, respectively.
2. With no input signal, adjust RT702 (L-CH), RT802 (R-CH) (See Fig. 3-6) so that the pointer indicates the specified position on the meter scale shown in Fig. 3-7.
3. Connect the equipment as shown in Fig. 3-4.
4. Feed a 1 kHz signal to TUNER INPUT jack, and adjust the attenuator for 1.0 V reading on the VTVM.
5. Adjust RT701 (L-CH), RT801 (R-CH) (See Fig. 3-6) so that the pointer indicates the specified position on the meter scale as shown in Fig. 3-8.

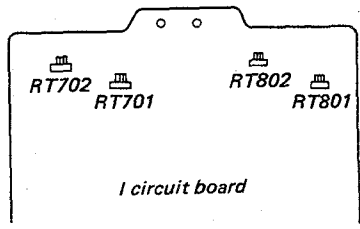

Fig. 3-6. Adjustment parts location

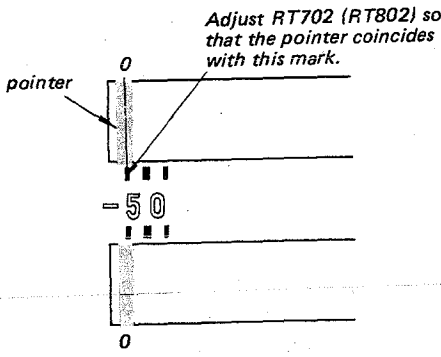

Fig. 3-7. Peak program meter adjustment

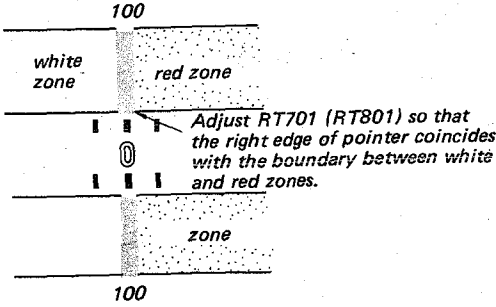
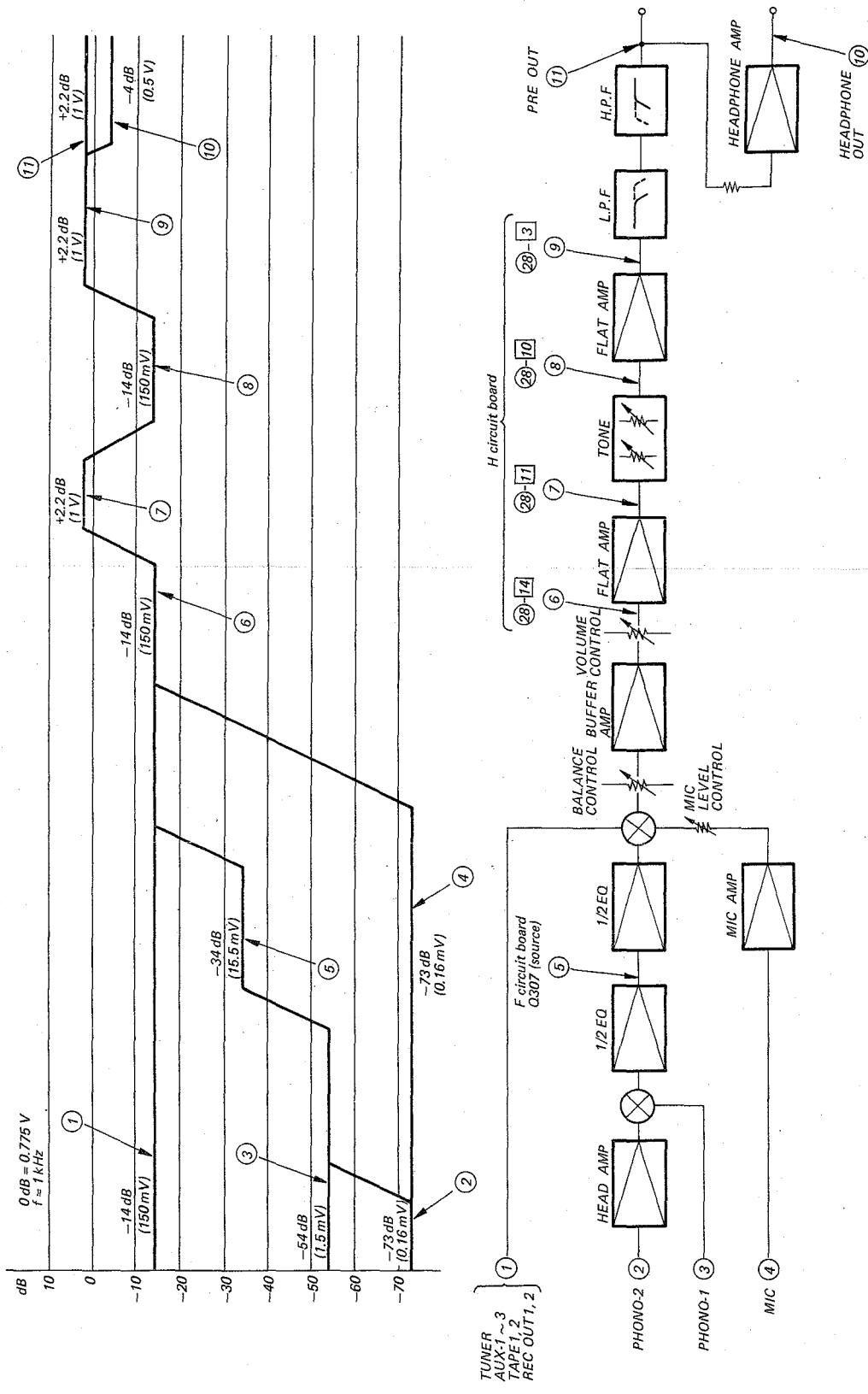

Fig. 3-8. Peak program meter adjustment

SECTION 4
DIAGRAMS

4-1. LEVEL DIAGRAM



Note: Signal voltages are measured with an ac VTVM and expressed in dB referred to 0.775 V, 1 kHz.
Level check point is shown as follows.
○ — Terminal No. of Connector
□ — Connector No.

MEMO

A series of horizontal dotted lines for writing, spanning the width of the page.



4-2. MOUNTING DIAGRAM – A Board (Volume Control) –
– Conductor Side –

11

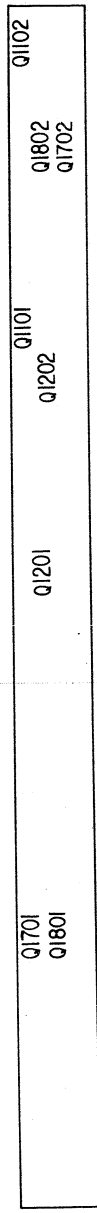
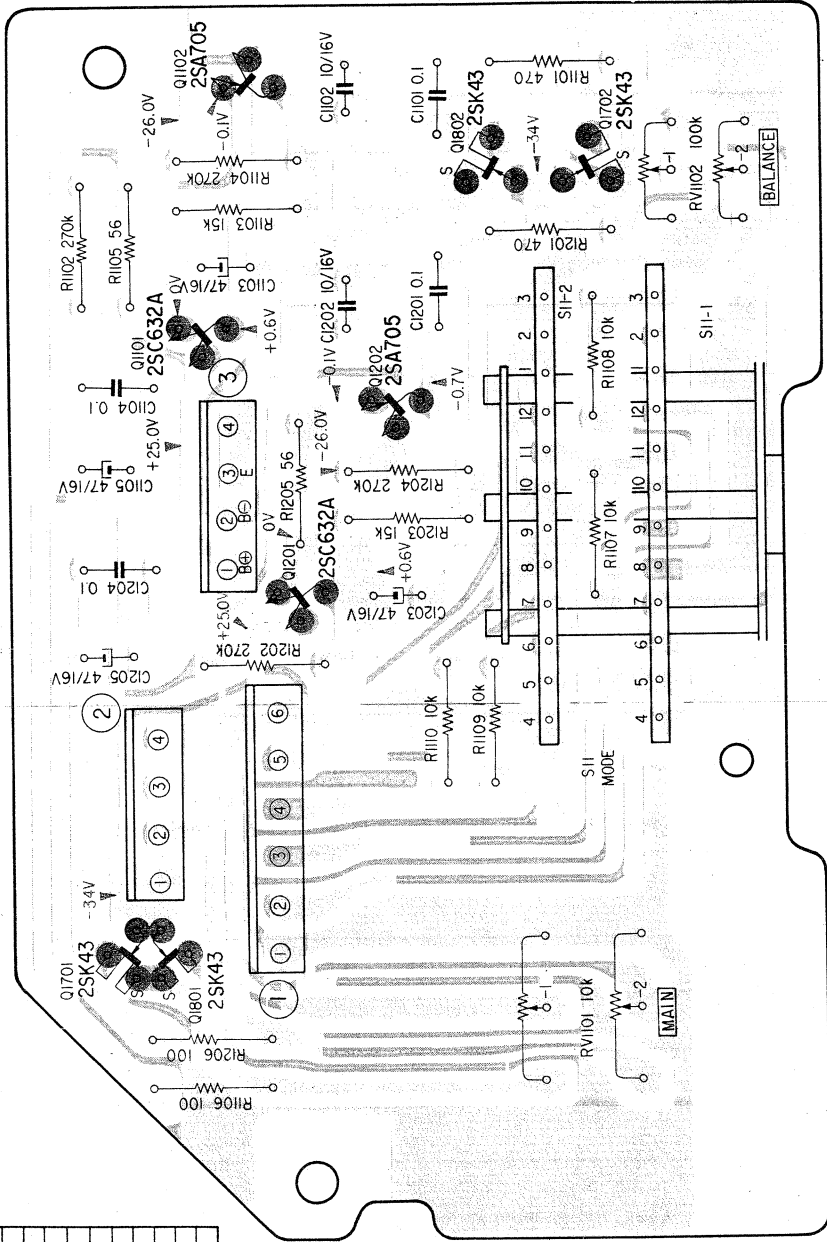

A Circuit Board

Connector No.	Terminal No. of Connector	Color of Lead Wire	Circuit Board No.	Connected to	Terminal No. of Connector
①	1	BLK	B	5	1
	2	BLU	C	15	4
	3	WHT/BLU	C	15	5
	4	WHT/GRN	B	7	4
	5	GRN	B	7	9
	6	BLK	E	21	2
②	1	WHT/BLK	C	12	8
	2	RED	B	4	6
	3	WHT/RED	B	4	1
	4	BLK	F	22	9
③	1	BRN	C	12	3
	2	BRN	B	9	2
	3	WHT/BRN	C	12	2
	4	WHT/BRN	B	9	1
	5	BLK	J	31	15
	6	BLK	C	12	1
	7	BLK	C	12	1
	8	BLK	C	12	1

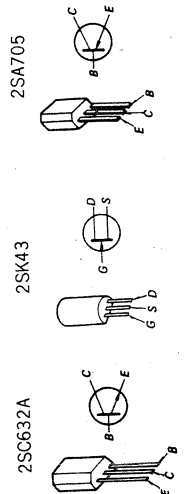
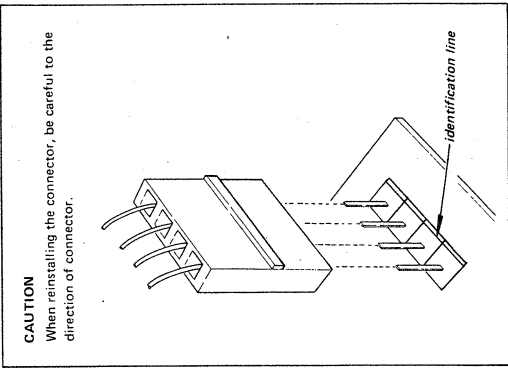



4-3. SCHEMATIC DIAGRAM— A Section (Volume Control) —

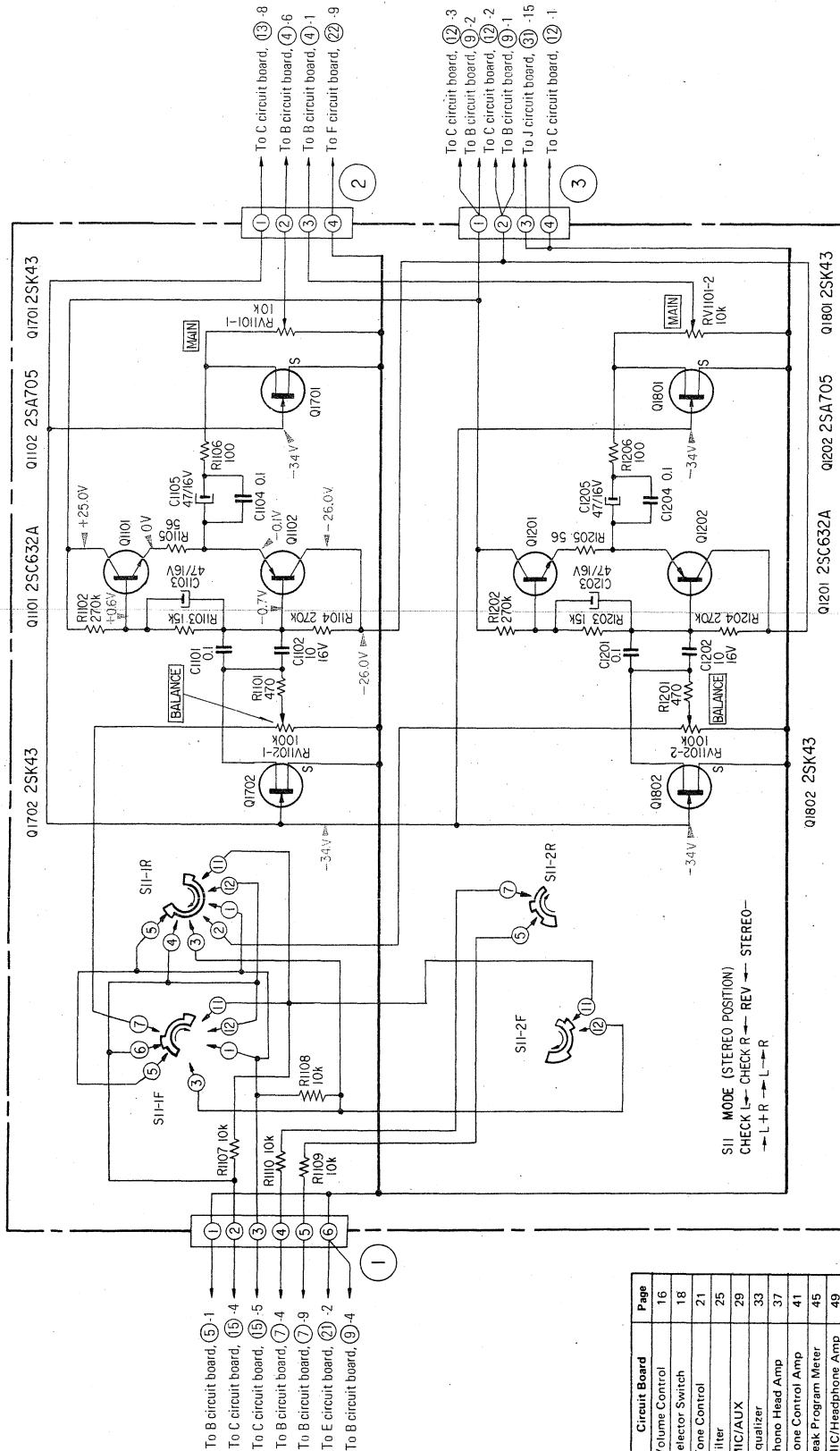

B

4-4. MOUNTING DIAGRAM – B Board (Selector Switch) –
– Conductor Side –

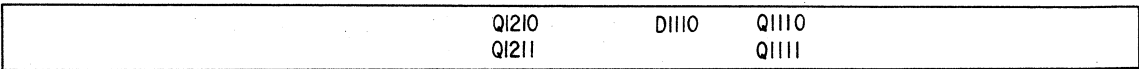
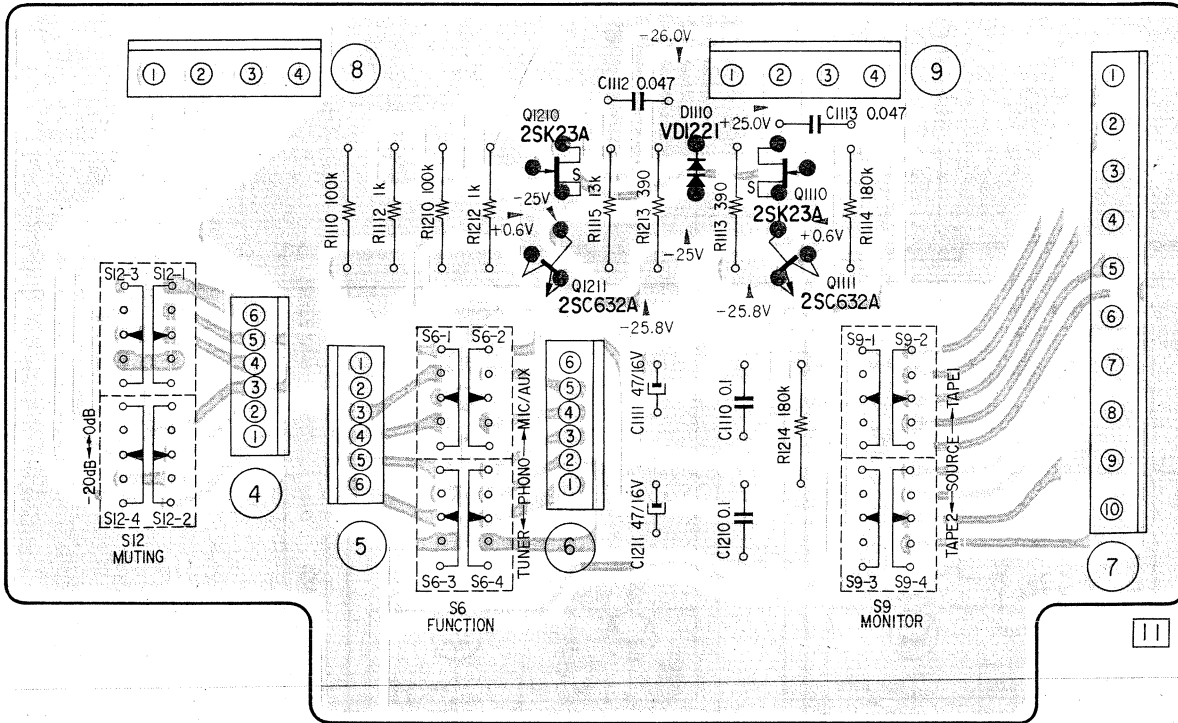

B Circuit Board

Connector No.	Terminal No. of Connector	Color of Lead Wire		Connected to		
		Conductors Sheath	Tube	Circuit Board	Connector No.	Terminal No. of Connector
④	1	WHT/RED		A	2	3
	2	RED	ORG	H	28	13
	3					
	4	WHT	ORG	H	28	14
	5	SHIELD	ORG	H	28	16
	6	RED		A	2	2
⑤	1	BLK		A	1	1
	2	SHIELD		H	28	16
	3	BLU		C	10	1
	4	WHT	YEL	K	35	9
	5	BRN		E	21	11
	6	WHT	RED	F	22	16
⑥	1	RED	RED	F	22	3
	2					
	3	WHT/BRN		E	21	13
	4	RED	YEL	K	35	10
	5	WHT/BLU		C	10	7
	6					
⑦	1	WHT/RED		C	15	7
	2	WHT/VLT		C	14	9
	3	WHT/GRN		C	14	3
	4	WHT/GRN		A	1	4
		WHT/GRN		E	21	14
	5	WHT/ORG		C	14	7
	6	RED		C	15	1
	7	VLT		C	14	4
	8	GRN		C	14	8
	9	GRN		A	1	5
⑧	1	WHT/ORG		D	20	42
	2	WHT/YEL		H	28	12
	3	ORG		D	20	44
	4	YEL		H	28	11
⑨	1	WHT/BRN		A	3	2
	2	BRN		A	3	1
	3	BLK		K	33	4
	4	BLK		A	1	6

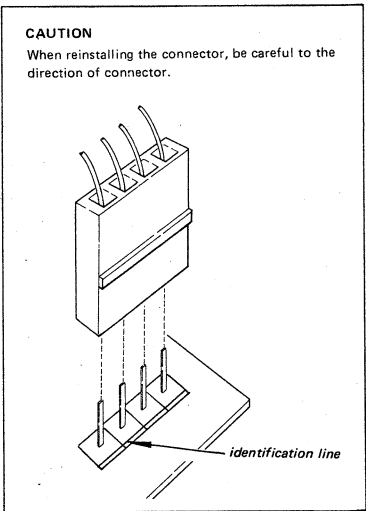
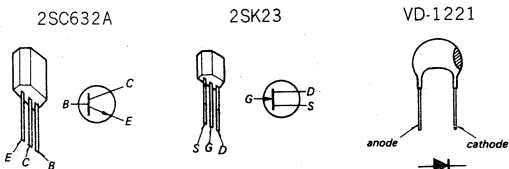

TAE-8450 TAE-8450

B B

4-5. SCHEMATIC DIAGRAM — B Section (Selector Switch) —

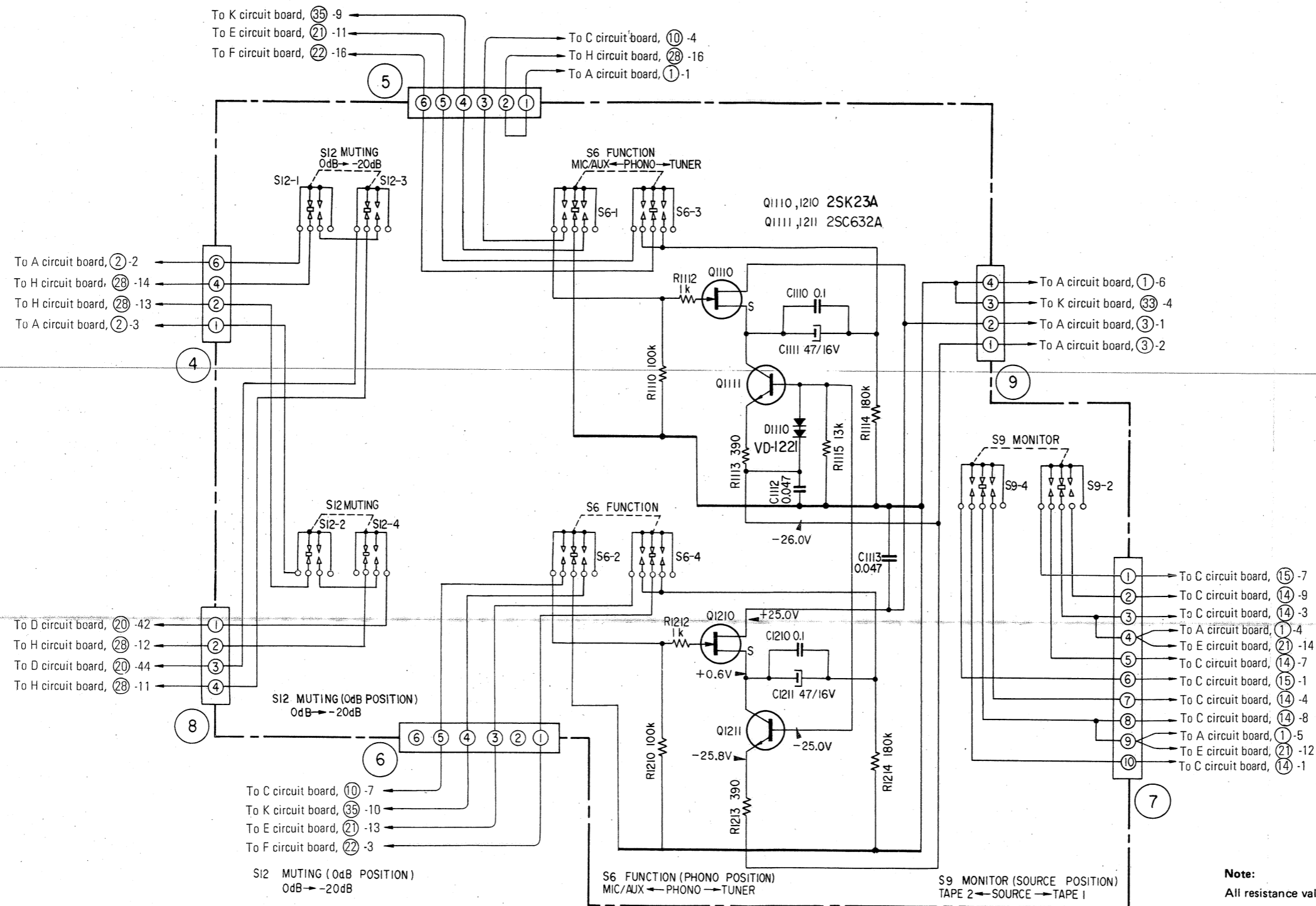

Ref. No.	Circuit Board	Page
A	Volume Control	16
B	Selector Switch	18
C	Tone Control	21
D	Filter	25
E	MIC/AUX	29
F	Equalizer	33
G	Phono Head Amp	37
H	Tone Control Amp	41
I	Peak Program Meter	45
J	MIC/Headphone Amp	49
K	Phono Jack	54
L	Power Supply	57

Note:

All resistance values are in ohms. k = 1,000 M = 1,000 k
 All capacitance values are in μF except as indicated with p, which means $\mu\mu\text{F}$.
 All voltages are dc measured with a VOM which has an input impedance of 20 k ohms/volt. No signal in.
 Voltage variations may be noted because of normal production tolerances.

TAE-8450 TAE-8450

4-6. MOUNTING DIAGRAM - C Board (Tone Control) - - Conductor Side -

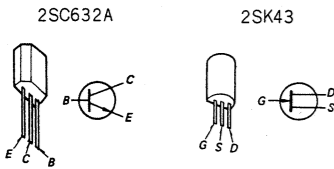

C Circuit Board

Connector No.	Terminal No. of Connector	Color of Lead Wire		Circuit Board	To	
		Conductors Sheath	Tube		Connector No.	Terminal No. of Connector
10	1	BLU		B	5	3
	2	WHT	BLU	K	35	5
	3	WHT	GRN	K	35	2
	4	ORG		E	21	3
	5	RED	GRN	K	35	1
	6	RED	BLU	K	35	4
	7	WHT/BLU		B	6	5
	8	WHT/ORG		E	21	1
12	1	BLK		A	3	4
	2	WHT/BRN		D	20	4
	3	WHT/BRN		A	3	2
	4	BRN		D	20	1
13	1	WHT/GRN		K	33	5
	2					
	3	RED	RED	●S25		4
	4	WHT/VLT		K	33	7
	5	GRN		K	33	6
	6	WHT	RED	●S25		10
	7	WHT/BLK		D	20	7
	8	WHT/BLK		A	2	1

●S25 shows reference number of switch.

C Circuit Board

Connector No.	Terminal No. of Connector	Color of Lead Wire		Circuit Board	To	
		Conductors Sheath	Tube		Connector No.	Terminal No. of Connector
14	1	ORG		B	7	10
	2	WHT	YEL	K	34	9
	3	GRN		B	7	8
	4	VLT		B	7	7
	5	WHT	GRN	K	34	5
	6	RED	YEL	K	34	10
	7	WHT/ORG		B	7	5
	8	WHT/GRN		B	7	3
	9	WHT/VLT		B	7	2
	10	RED	GRN	K	34	4
15	1	RED		B	7	6
	2	WHT	CLEAR	K	34	1
	3	WHT	ORG	K	33	1
	4	BLU		A	1	2
	5	WHT/BLU		A	1	3
	6	RED	ORG	K	33	3
	7	WHT/RED		B	7	1
	8	RED	CLEAR	K	34	3

C Circuit Board

Connector No.	Terminal No. of Connector	Color of Lead Wire		Circuit Board	To	
		Conductors Sheath	Tube		Connector No.	Terminal No. of Connector
16	1	WHT	RED	D	20	37
	2	WHT/VLT		D	20	30
	3	WHT/GRN		D	20	34
	4	WHT/BLU		D	20	38
17	1	YEL	RED	D	20	26
	2	SHIELD	RED	D	20	
	3	WHT	RED	D	20	24
	4	RED	RED	D	20	22
18	1	SHIELD	CLEAR	D	20	
	2	YEL	CLEAR	D	20	16
	3	RED	CLEAR	D	20	18
	4	WHT	CLEAR	D	20	20
19	1	WHT	CLEAR	D	20	35
	2	BLU		D	20	40
	3	VLT		D	20	32
	4	GRN		D	20	28

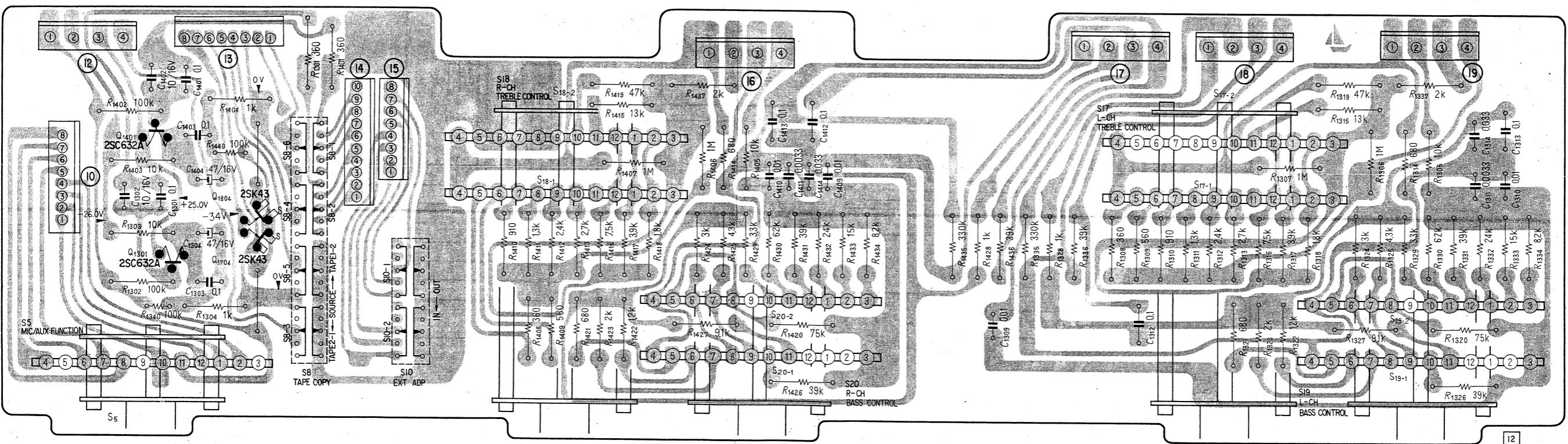
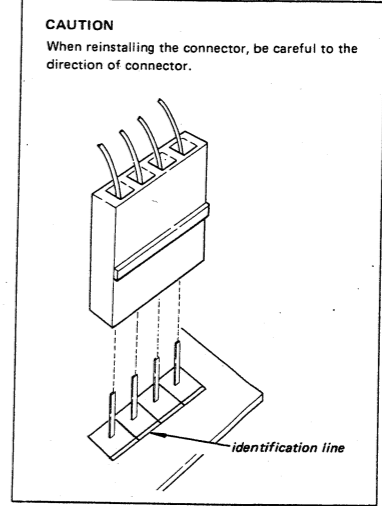

TAE-8450 TAE-8450



4.7. SCHEMATIC DIAGRAM – C Section (Tone Control) –

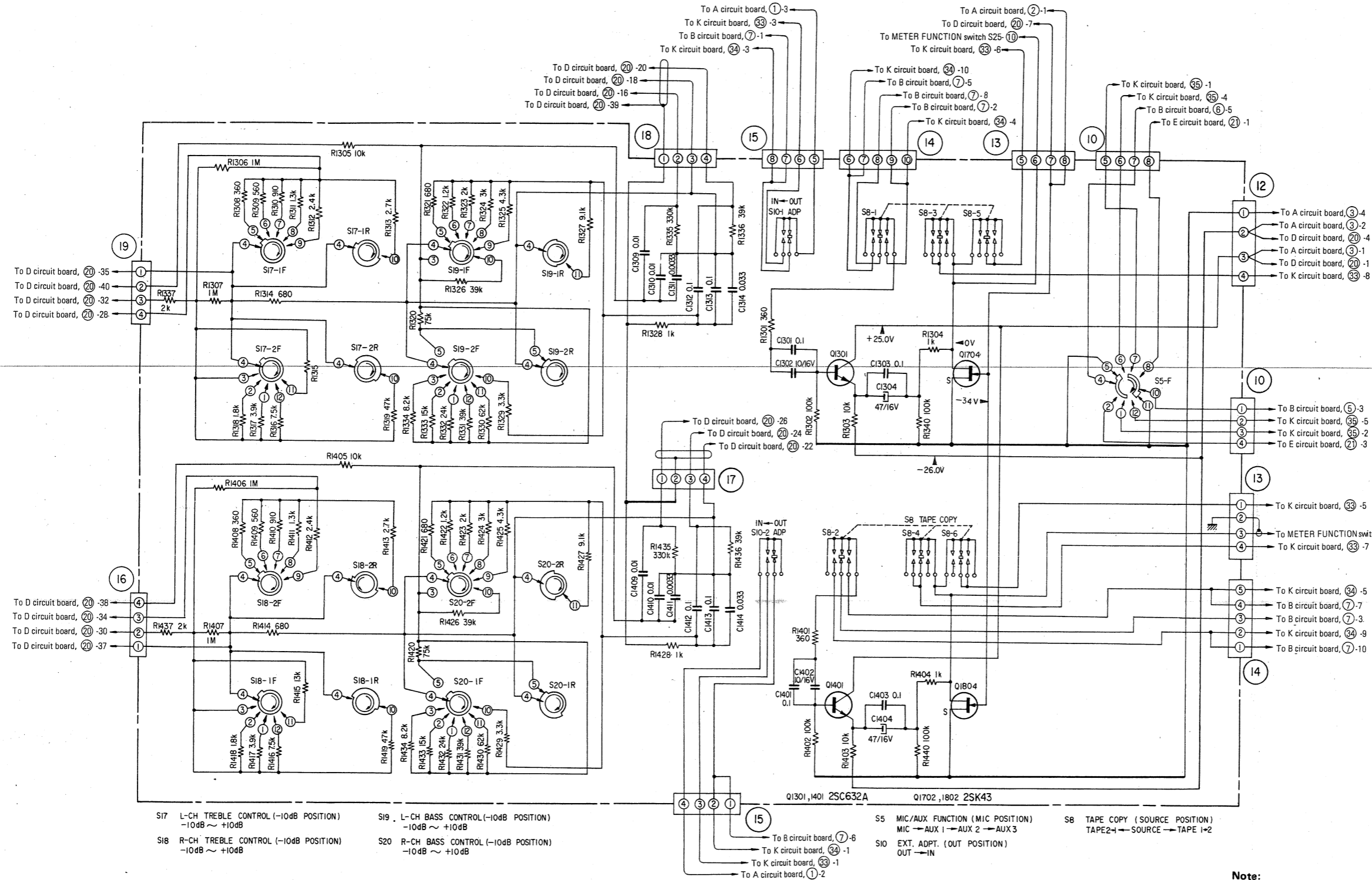

Ref. No.	Circuit Board	Page
A	Volume Control	16
B	Selector Switch	18
C	Tone Control	21
D	Filter	25
E	MIC/AUX	29
F	Equalizer	33
G	Phono Head Amp	37
H	Tone Control Amp	41
I	Peak Program Meter	45
J	MIC/Headphone Amp	49
K	Phono Jack	54
L	Power Supply	57

Note:

All resistance values are in ohms. k = 1,000 M = 1,000 k
 All capacitance values are in μF except as indicated with p, which means μM .
 All voltages are dc measured with a VOM which has an input impedance of 20 k ohms/volt. No signal in.
 Voltage variations may be noted because of normal production tolerances.

TAE-8450 TAE-8450



4-8. MOUNTING DIAGRAM – D Board (Filter) – – Conductor Side –

D Circuit Board

Connector No.	Terminal No. of Connector	Color of Lead Wire		Connected to		
		Conductor's Sheath	Tube	Circuit Board Connector No.	Terminal No. of Connector	
(20) - A	1	BRN		F	22	18
		BRN		C	12	3
	3	BLK		H	28	5
		SHIELD (20 - 5, 9 (BLK, TUBE) IS SHIELDED)				
	5	WHT	ORG	K	32	1
		WHT	BLK	● S25		(9)
	7	WHT/BLK		L	38	4
		WHT/BLK		C	13	7
	9	RED	ORG	K	32	3
		RED	BLK	● S25		(3)
	11	RED	CLEAR	K	32	8
	13	RED	YEL	J	31	6
	15	WHT	YEL	J	31	1
	17	WHT	CLEAR	K	32	6
	19					
	21	WHT	BLU	H	28	10
	23	RED	BLU	H	28	9
25	WHT/GRY		H	28	7	
27	GRY		H	28	1	
29	WHT/BRN		H	28	2	
31	WHT/BLK		H	28	8	
33	WHT/RED		H	28	6	
35	WHT	CLEAR	C	19	1	
37	WHT	RED	C	16	1	
39	SHIELD	CLEAR	C	18	1	
41	SHIELD (of (20) - 35)					
43	SHIELD (of (20) - 35), CLEAR					
	BLK		H	28	4	
(20) - B	2	WHT/BRN		F	22	17
	4	WHT/BRN		C	12	2
	6	BLK		J	31	2
	8	VLT		I	29	13
	10	RED	GRN	J	31	7
	12					
	14	WHT	GRN	J	31	8
	16	YEL	CLEAR	C	18	2
	18	RED	CLEAR	C	18	3
	20	WHT	CLEAR	C	18	4
	22	RED	RED	C	17	4
	24	WHT	RED	C	17	3
	26	YEL	RED	C	17	1
	28	GRN		C	19	4
	30	VLT		C	19	3
	32	WHT/VLT		C	16	2
	34	WHT/GRN		C	16	3
36	RED		H	28	3	
38	WHT/BLU		C	16	4	
40	BLU		C	19	2	
42	WHT/ORG		B	8	1	
44	ORG		B	8	3	

● S25 shows reference number of switch.

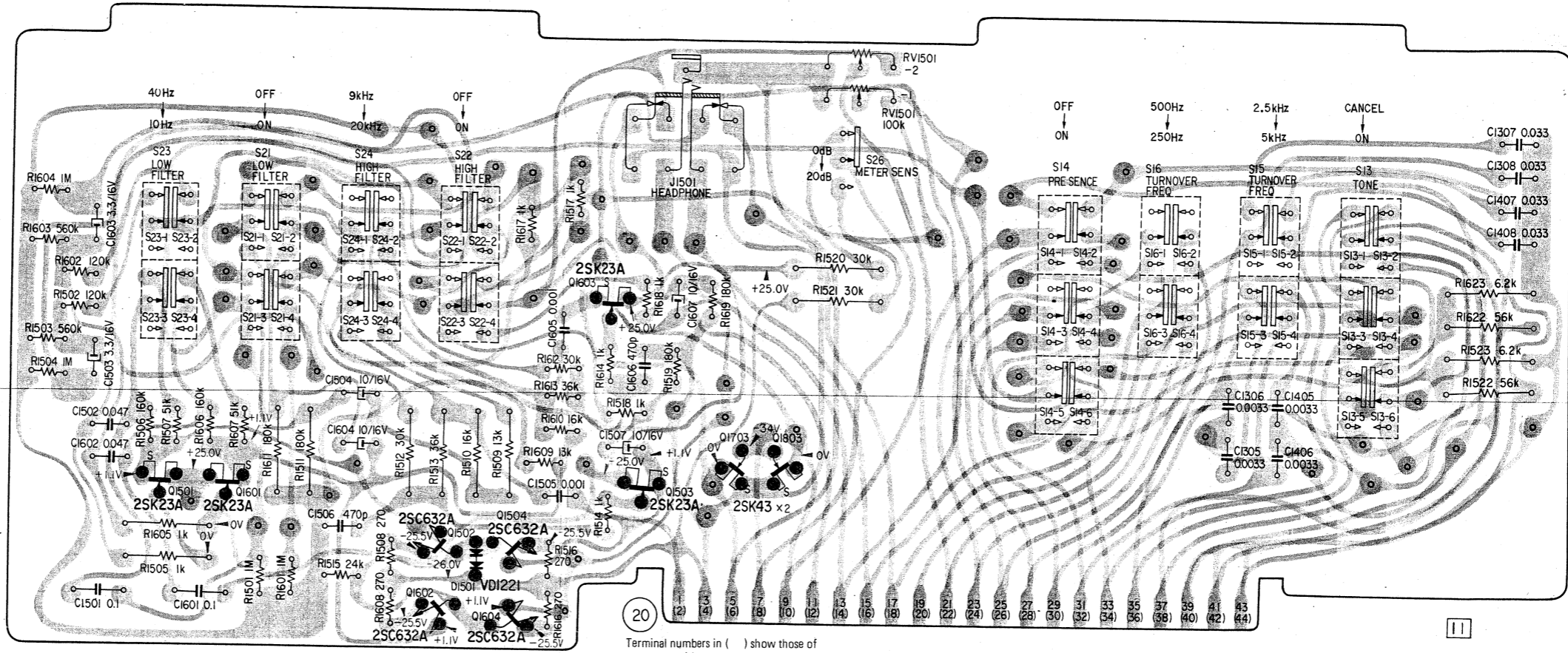

Terminal numbers in () show those of component side pattern.

Q1501	Q1601	Q1502	Q1501	Q1504	Q1603	Q1503	Q1703	Q1803
		Q1602	Q1604					

Note: ... Conductor Side Pattern
 ... Component Side Pattern

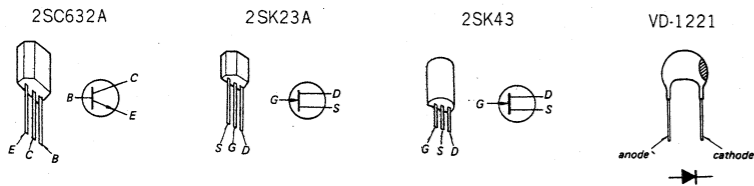

TAE-8450 TAE-8450

D D

4-9. SCHEMATIC DIAGRAM - D Section (Filter) -

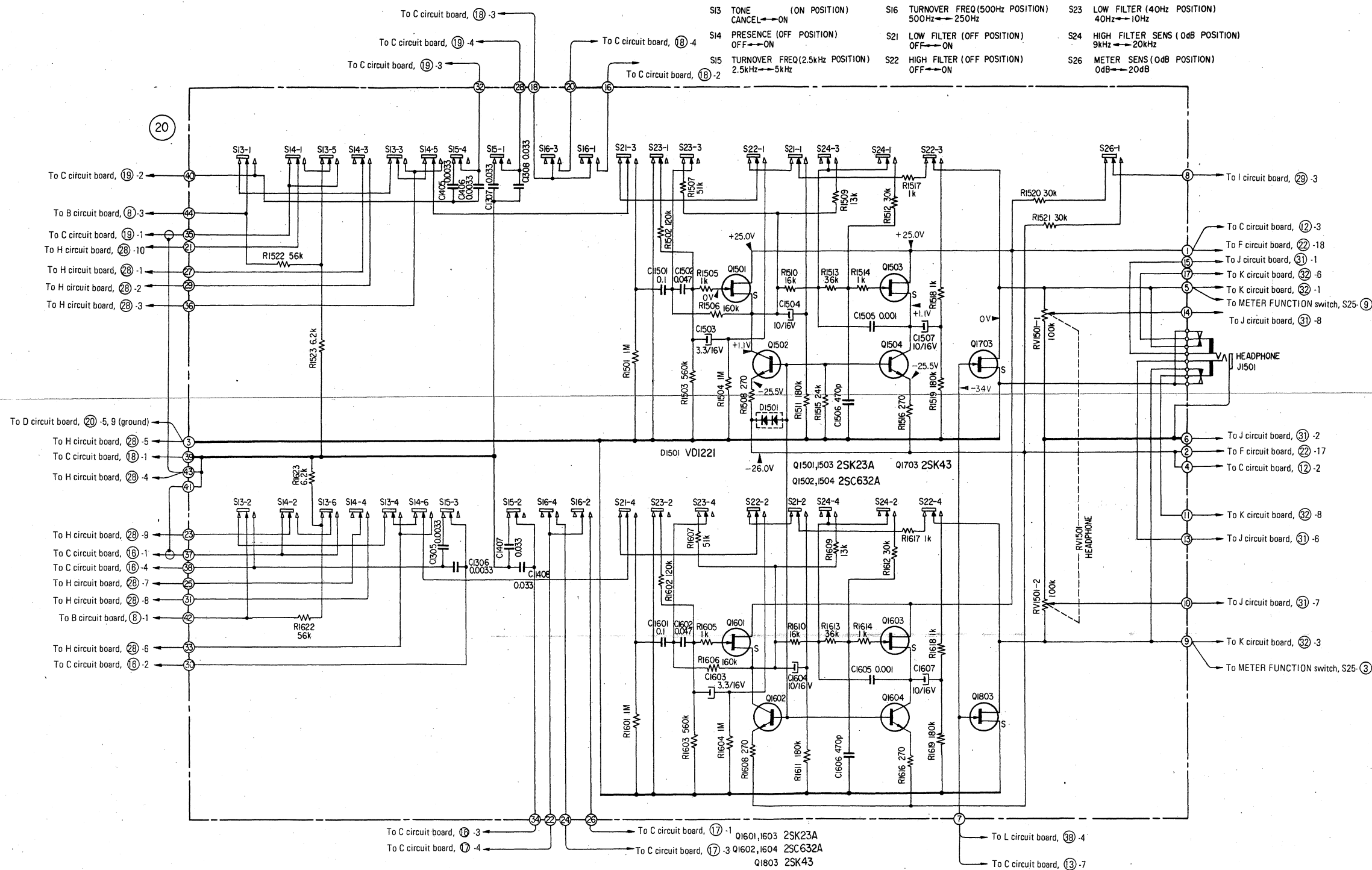

Note:

All resistance values are in ohms. k = 1,000 M = 1,000 k
 All capacitance values are in μF except as indicated with p, which means $\mu\mu\text{F}$.
 All voltages are dc measured with a VOM which has an input impedance of 20 k ohms/volt. No signal in.
 Voltage variations may be noted because of normal production tolerances.

TAE-8450 TAE-8450

E E

**4-10. MOUNTING DIAGRAM – E Board (MIC/AUX) –
– Conductor Side –**

E Circuit Board

Connector No.	Terminal No. of Connector	Color of Lead Wire		Connected to		
		Conductor's Sheath	Tube	Circuit Board Connector No.	Terminal No. of Connector	
②	1	WHT/ORG		C	10	8
	2	BLK		A	1	6
	3	ORG		C	10	4
	4	SHIELD	ORG	J	31	16
	5	WHT	ORG	J	31	14
	6	RED	ORG	J	31	13
	7					
	8	WHT/VLT		J	31	11
		WHT/VLT		● S25		②
	9	VLT		● S25		⑧
		VLT		J	31	10
	10	BLK		J	31	16
	11	BRN		B	5	5
	12	GRN		B	7	9
	13	WHT/BRN		B	6	3
	14	WHT/GRN		B	7	4
	15	YEL		● S25		⑦
	16	WHT/YEL		● S25		①
17	GRY		J	31	9	
18	WHT/GRY		J	31	12	

● S25 shows reference number of switch.

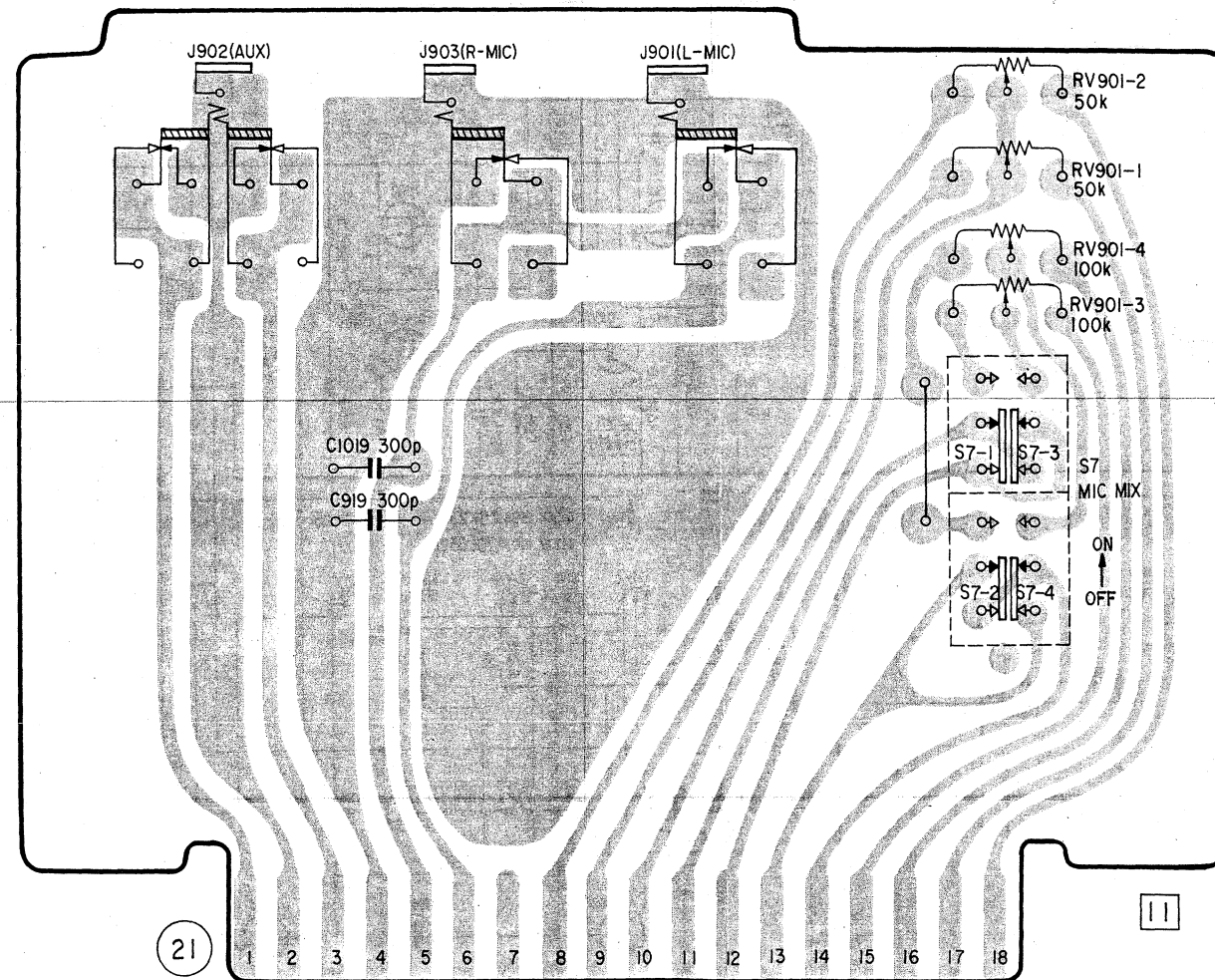

4-11. SCHEMATIC DIAGRAM – E Section (MIC/AUX) –

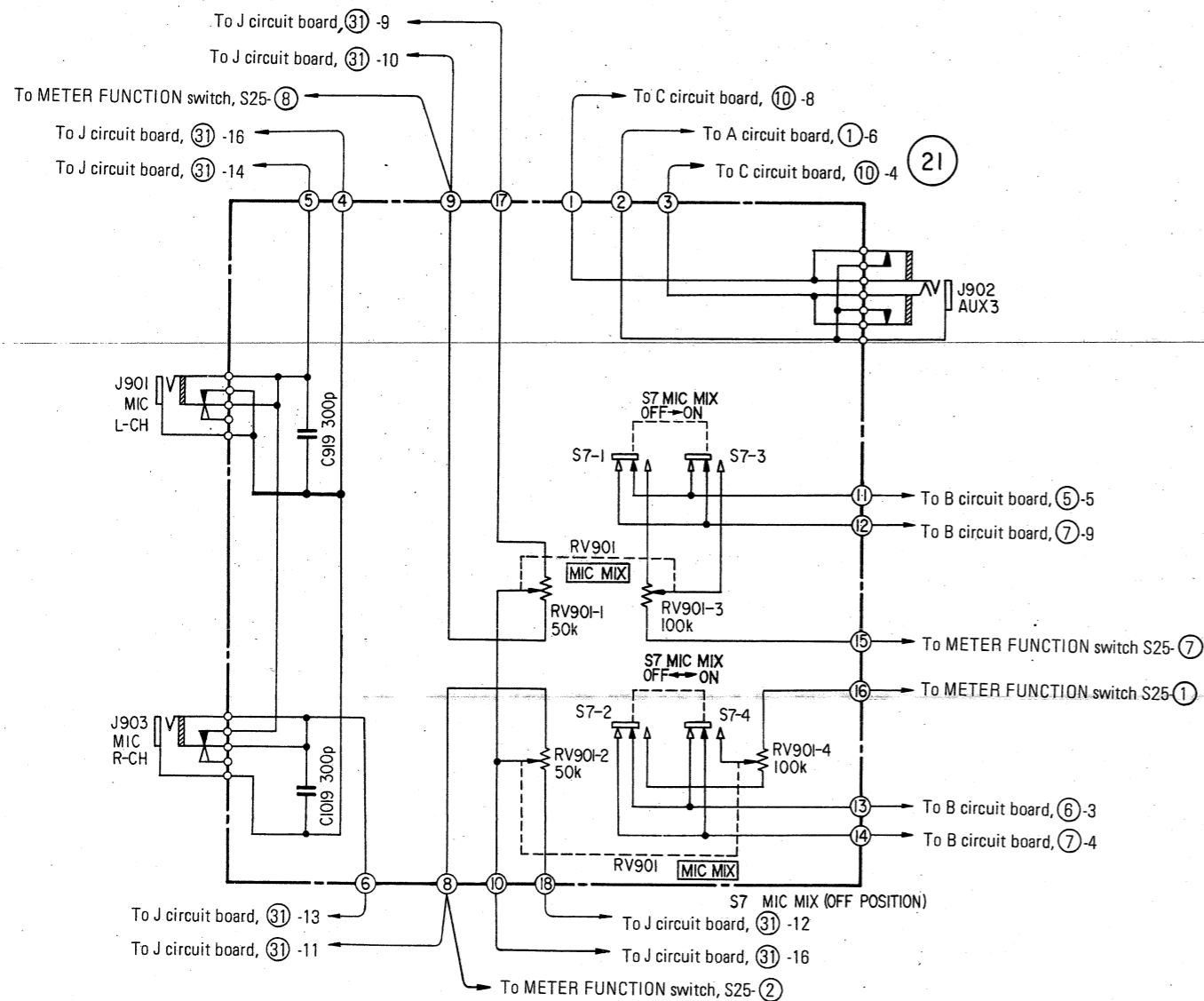

Ref. No.	Circuit Board	Page
A	Volume Control	16
B	Selector Switch	18
C	Tone Control	21
D	Filter	25
E	MIC/AUX	29
F	Equalizer	33
G	Phono Head Amp	37
H	Tone Control Amp	41
I	Peak Program Meter	45
J	MIC/Headphone Amp	49
K	Phono Jack	54
L	Power Supply	57

TAE-8450 TAE-8450

F F

4-12. MOUNTING DIAGRAM – F Board (Equalizer) –
– Conductor Side –

USA Model
(Serial No. up to 800, 140)

F Circuit Board

Connector No.	Terminal No. of Connector	Color of Lead Wire		Circuit Board	Connector No.	Terminal No. of Connector
		Conductors Sheath	Tube			
22	1	BRN		G	R110	
	2					
	3	RED	RED	B	6	1
	4					
	5					
	6					
	7	RED	YEL	G	26	10
	8	SHIELD	YEL	G	26	6
	9	BLK		A	2	4
	10	SHIELD	RED			
	11					
	12	WHT	YEL	G	26	4
	13					
	14					
	15					
	16	WHT	RED	B	5	6
	17	WHT/BRN		D	20	2
	18	BRN		H	28	17
			D	20	1	
			H	28	18	

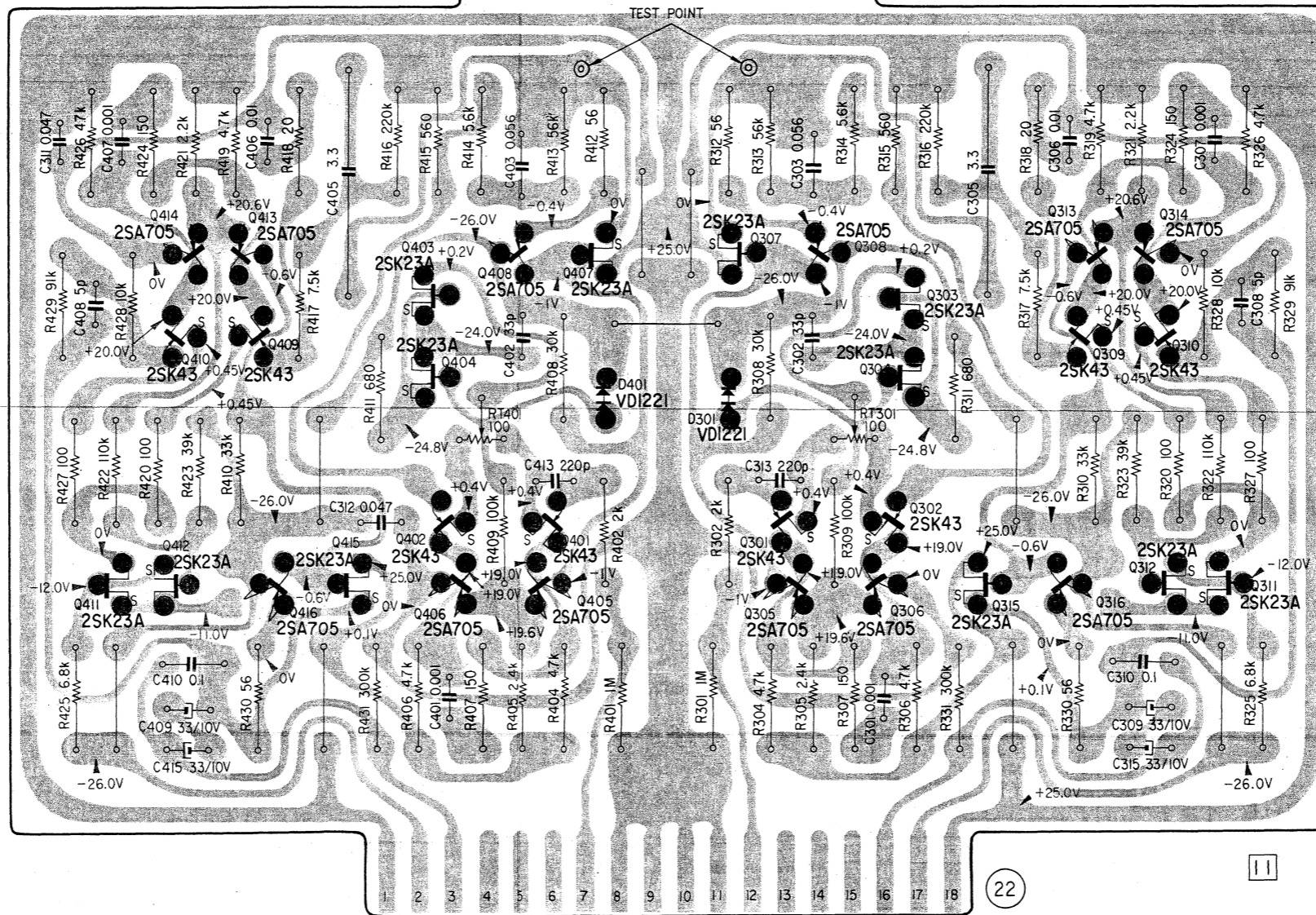
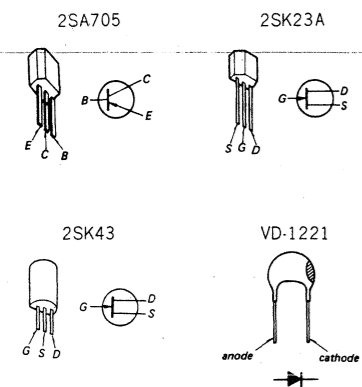

Q414	Q413	Q403	Q408	Q407	Q307	Q308	Q313	Q314
Q410	Q409	Q404	Q401		Q301	Q304	Q309	Q310
Q411	Q412	Q416	Q415	Q406	Q405	Q305	Q306	Q315
							Q302	Q316
							Q303	Q312
							Q305	Q311

TAE-8450 TAE-8450

F

F

USA Model
(Serial No. 800, 141 and later)
AEP Model

4-13. MOUNTING DIAGRAM - F Board (Equalizer) -
- Conductor Side -

F Circuit Board

Connector No.	Terminal No. of Connector	Color of Lead Wire		Connected to		
		Conductor's Sheath	Tube	Circuit Board	Connector No.	Terminal No. of Connector
22	1	BRN		G	R110	
	2					
	3	RED	RED	B	6	1
	4					
	5					
	6					
	7	RED	YEL	G	26	10
	8	SHIELD	YEL	G	26	6
	9	BLK		A	2	4
	10	SHIELD	RED			
	11					
	12	WHT	YEL	G	26	4
	13					
	14					
	15					
	16	WHT	RED	B	5	6
	17	WHT/BRN		D	20	2
	18	WHT/BRN		H	28	17
	BRN		D	20	1	
	BRN		H	28	18	

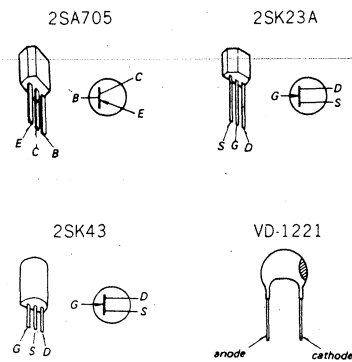
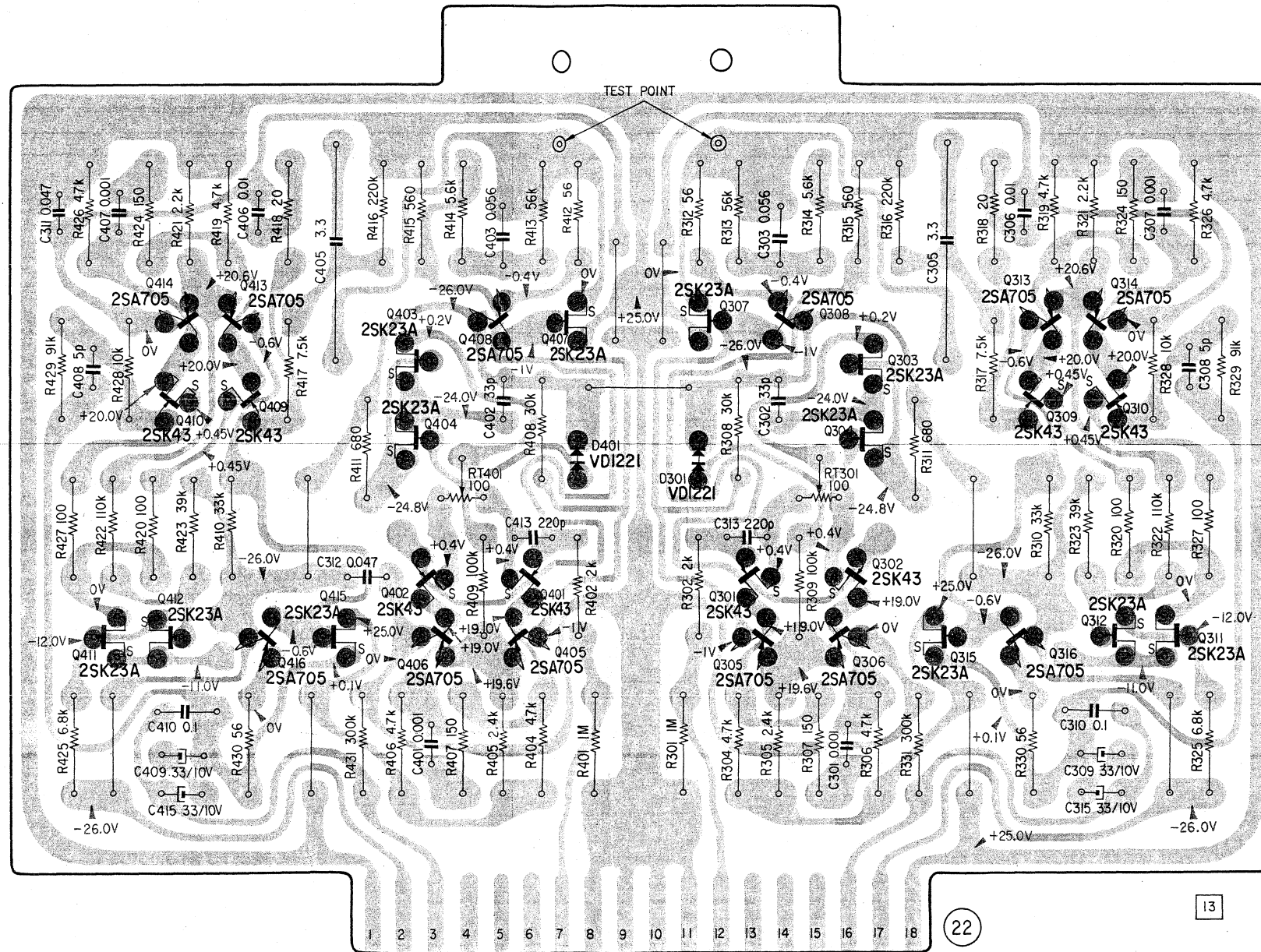

Q414	Q413	Q403	Q408	Q407	Q307	Q308	Q313	Q314
Q410	Q409	Q404	Q401		Q301	Q304	Q309	Q310
Q411	Q412	Q416 Q415	Q406 Q405		Q305	Q306	Q315	Q316 Q312
								Q311

TAE-8450 TAE-8450

F F

4-14. SCHEMATIC DIAGRAM — F Section (Equalizer) —

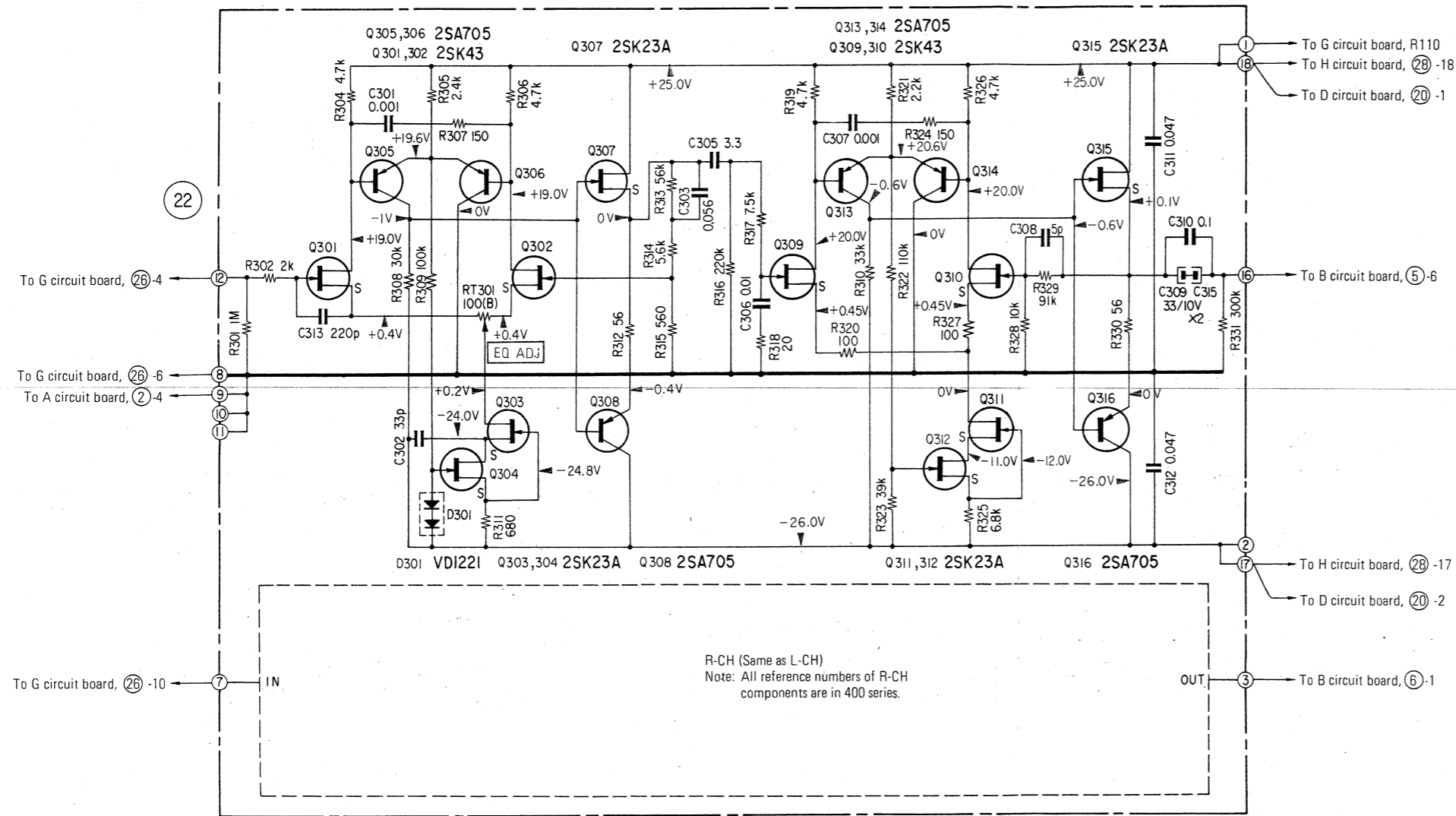

Ref. No.	Circuit Board	Page
A	Volume Control	16
B	Selector Switch	18
C	Tone Control	21
D	Filter	25
E	MIC/AUX	29
F	Equalizer	33
G	Phono Head Amp	37
H	Tone Control Amp	41
I	Peak Program Meter	45
J	MIC/Headphone Amp	49
K	Phono Jack	54
L	Power Supply	57

Note:

All resistance values are in ohms. k = 1,000 M = 1,000 k
 All capacitance values are in μF except as indicated with p, which means $\mu\mu\text{F}$.
 All voltages are dc measured with a VOM which has an input impedance of 20 k ohms/volt. No signal in.
 Voltage variations may be noted because of normal production tolerances.

TAE-8450 TAE-8450



4-15. MOUNTING DIAGRAM – G Board (Phono Head Amp) – – Conductor Side –

G Circuit Board

Connector No.	Terminal No. of Connector	Color of Lead Wire		Circuit Board	Connected to	
		Conductor's Sheath	Tube		Connector No.	Terminal No. of Connector
24	1	WHT/GRN		●S3		(7)
	2	WHT/BLU		●S3		(8)
	3	WHT/VLT		●S3		(9)
	4	WHT/GRY		●S3		(10)
26	1	RED	YEL	F	22	7
	2	WHT/RED		K	36	8
	3	WHT/YEL		K	36	5
	4	WHT/ORG		K	36	1
	5	SHIELD	YEL	F	22	8
	6	BLK		K	36	6
	7	WHT	YEL	F	22	12
	8	RED		K	36	7
	9	YEL		K	36	3
	10	ORG		K	36	2
27	1	GRY		●S3		(4)
	2	VLT		●S3		(3)
	3	BLU		●S3		(2)
	4	GRN		●S3		(1)

●S3 shows reference number of switch.

CAUTION
When reinstalling the connector, be careful to the direction of connector.

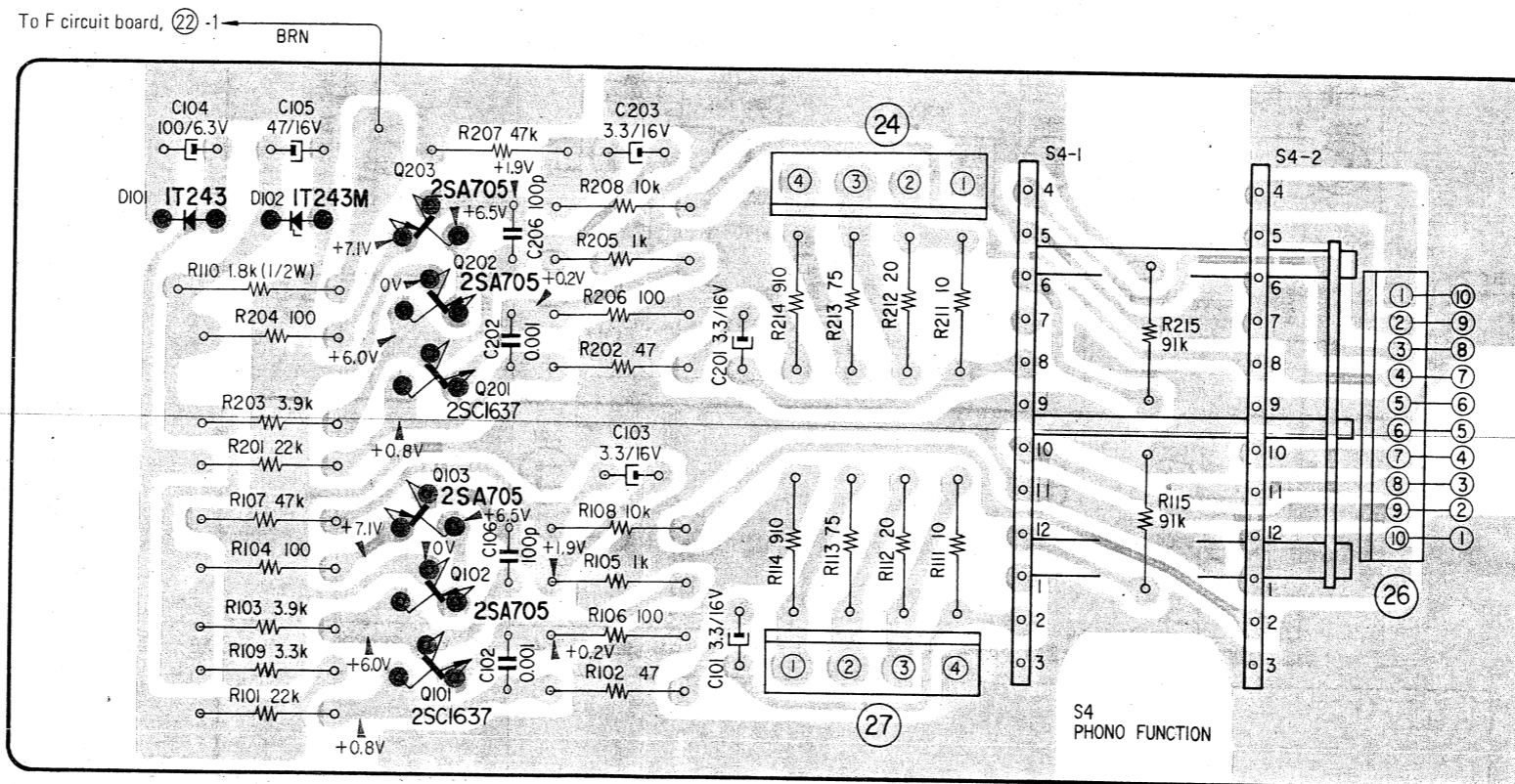
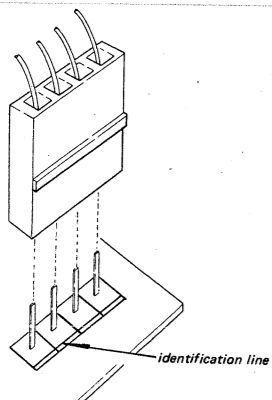

11

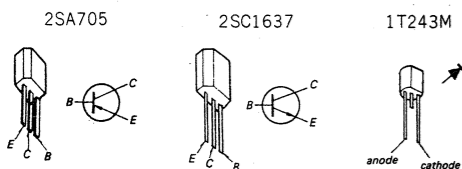

TAE-8450 TAE-8450

G G

4-16. SCHEMATIC DIAGRAM — G Section (Phono Head Amp) —

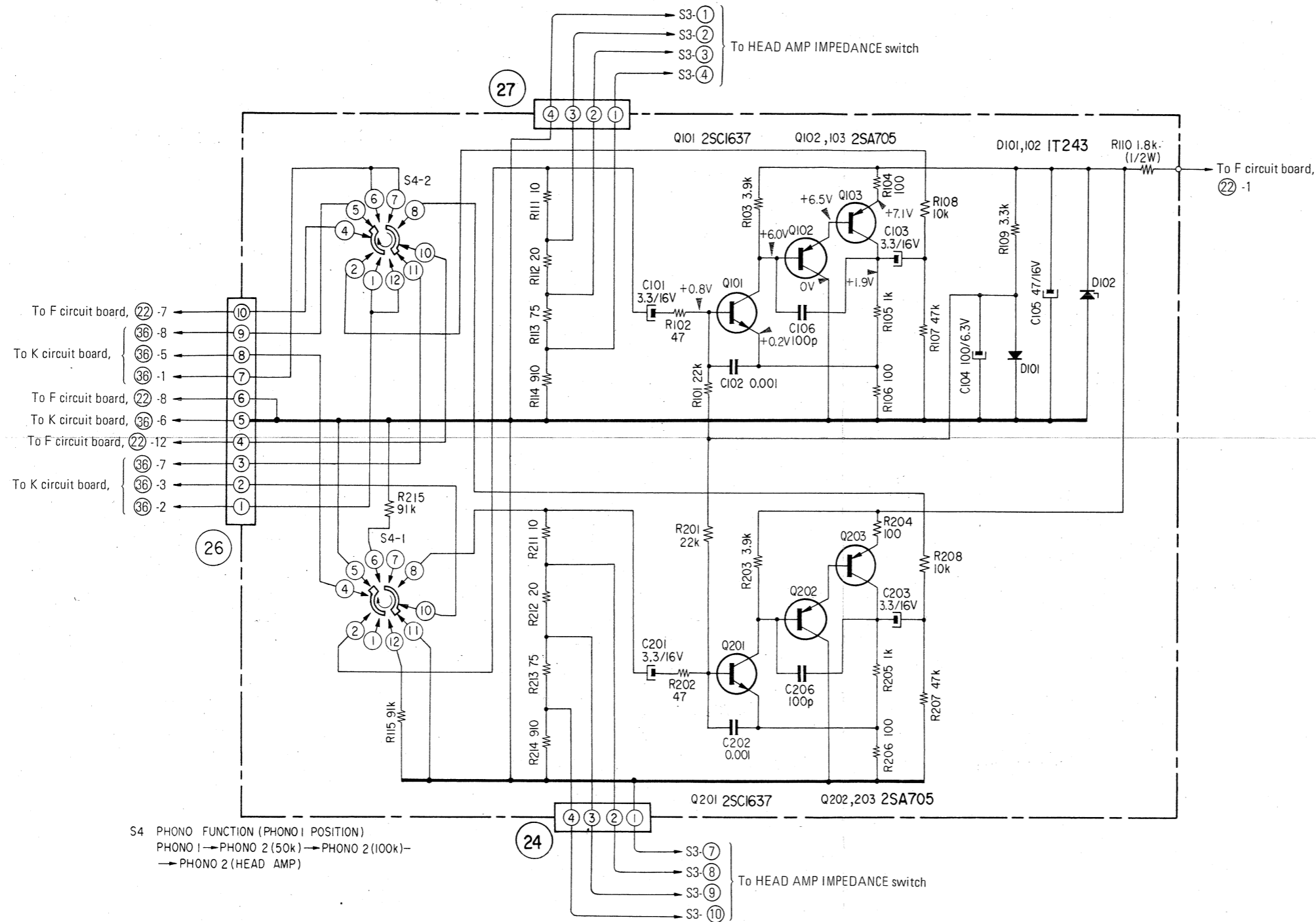

Ref. No.	Circuit Board	Page
A	Volume Control	16
B	Selector Switch	18
C	Tone Control	21
D	Filter	25
E	MIC/AUX	29
F	Equalizer	33
G	Phono Head Amp	37
H	Tone Control Amp	41
I	Peak Program Meter	45
J	MIC/Headphone Amp	49
K	Phono Jack	54
L	Power Supply	57

Note:
 All resistance values are in ohms. k = 1,000 M = 1,000 k
 All capacitance values are in μF except as indicated with p, which means μM .
 All voltages are dc measured with a VOM which has an input impedance of 20 k ohms/volt. No signal in.
 Voltage variations may be noted because of normal production tolerances.

TAE-8450 TAE-8450



4-17. MOUNTING DIAGRAM — H Board (Tone Control Amp) —
— Conductor Side —

H Circuit Board

Connector No.	Terminal No. of Connector	Color of Lead Wire		To		
		Conductors Sheath	Tube	Circuit Board Connector No.	Terminal No. of Connector	
(28)	1	GRY		D	20	27
	2	WHT/BRN		D	20	29
	3	RED		D	20	36
	4	BLK		D	20	43
	5	BLK		D	20	3
	6	WHT/RED		D	20	33
	7	WHT/GRY		D	20	25
	8	WHT/BLK		D	20	31
	9	RED	BLU	D	20	23
	10	WHT	BLU	D	20	21
	11	YEL		B	8	4
	12	WHT/YEL		B	8	2
	13	RED	ORG	B	4	2
	14	WHT	ORG	B	4	4
	15	BLK		H	28	5
	16	BLK		J	31	4
	17	WHT/BRN		F	22	17
	18	BRN		F	22	18

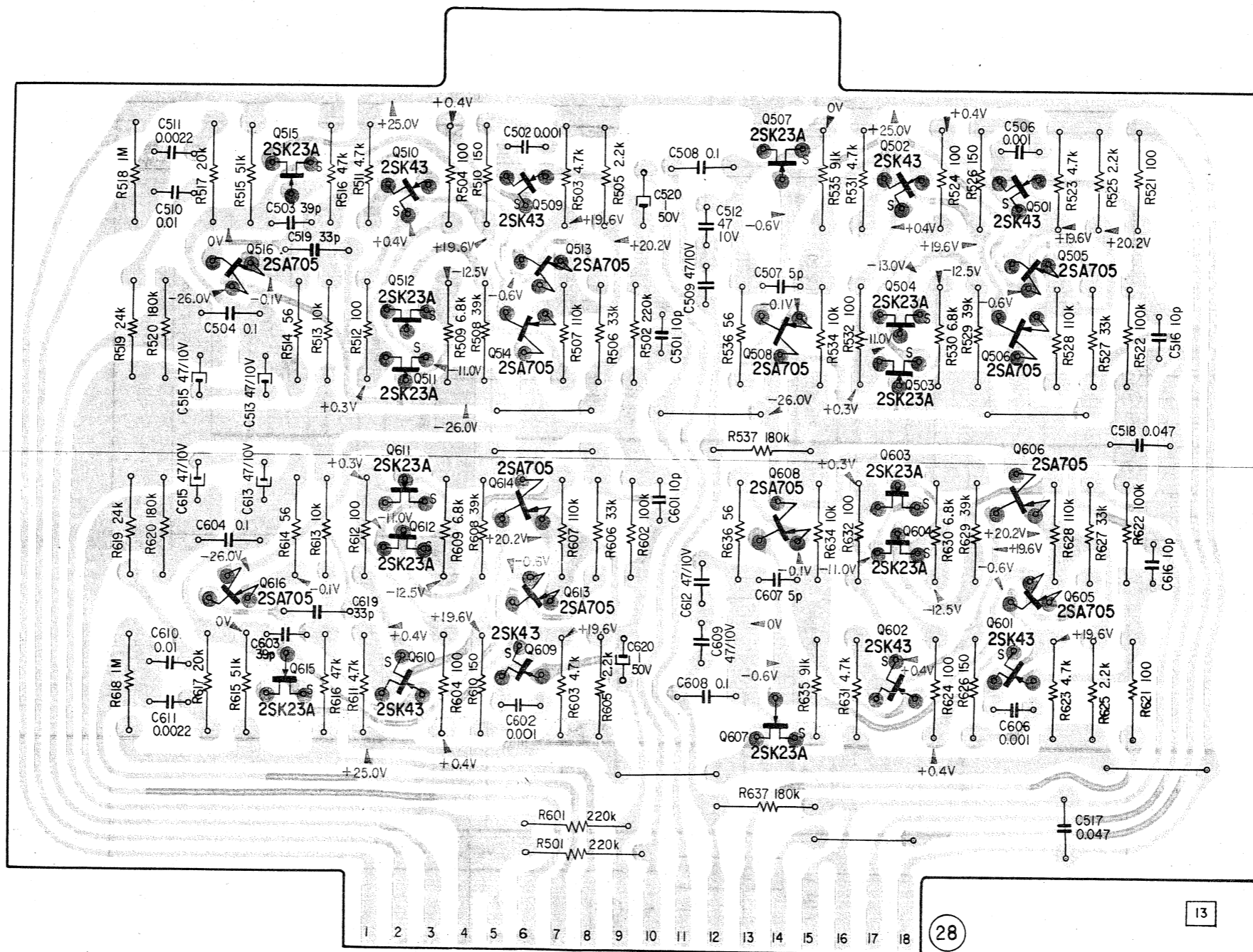

2SA705

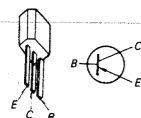

2SK23A

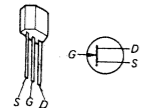

2SK43

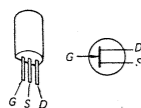

Q515	Q510	Q509	Q507	Q502	Q501
Q516	Q512	Q513	Q508	Q504	Q505
Q616	Q611	Q614	Q608	Q603	Q606
Q615	Q612	Q613	Q607	Q604	Q605
	Q610	Q609		Q602	Q601

TAE-8450 TAE-8450



4-18. SCHEMATIC DIAGRAM — H Section (Tone Control Amp) —

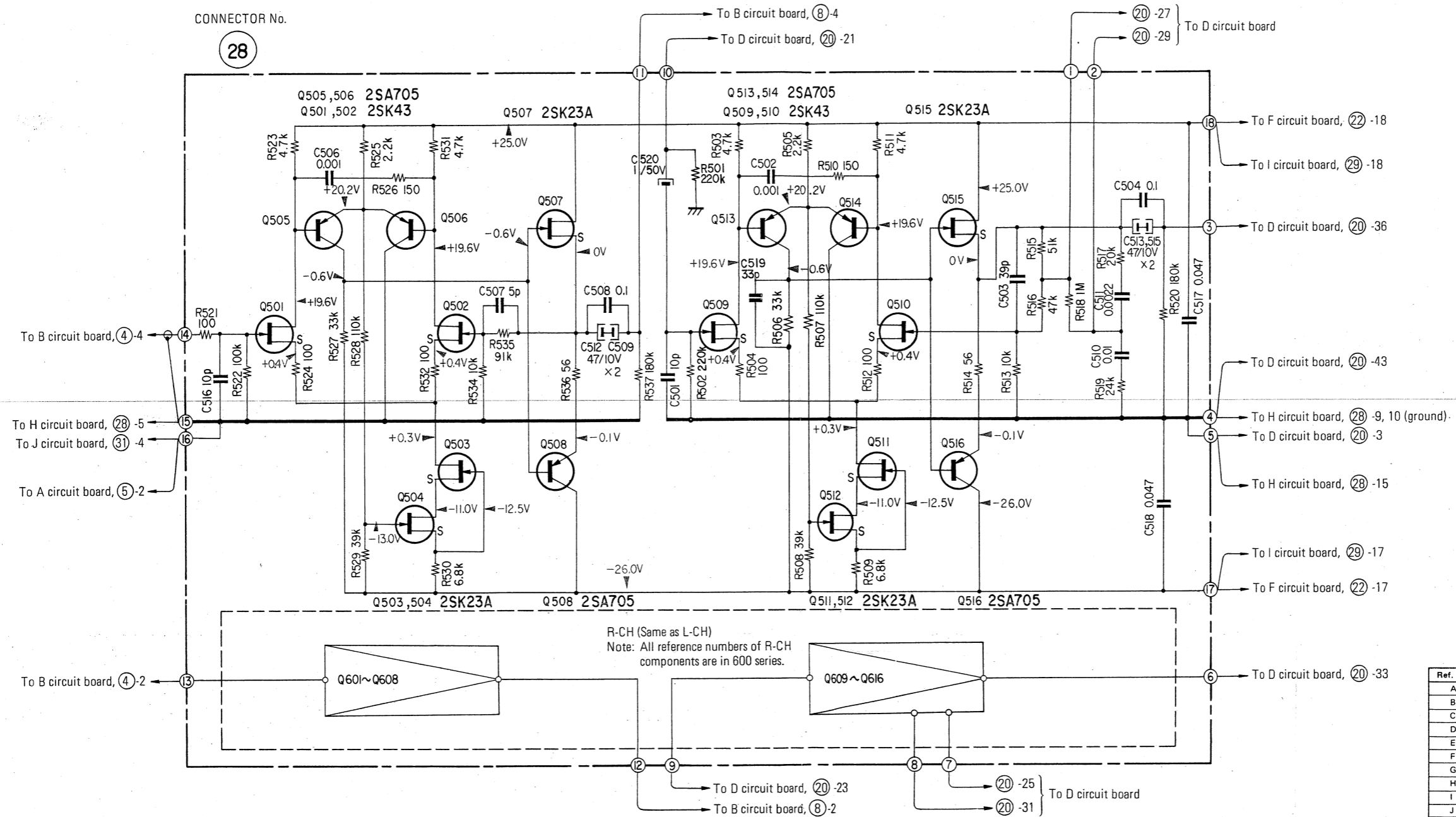

Ref. No.	Circuit Board	Page
A	Volume Control	16
B	Selector Switch	18
C	Tone Control	21
D	Filter	25
E	MIC/AUX	29
F	Equalizer	33
G	Phono Head Amp	37
H	Tone Control Amp	41
I	Peak Program Meter	45
J	MIC/Headphone Amp	49
K	Phono Jack	54
L	Power Supply	57

Note:
 All resistance values are in ohms. k = 1,000 M = 1,000 k
 All capacitance values are in μF except as indicated with p, which means $\mu\mu\text{F}$.
 All voltages are dc measured with a VOM which has an input impedance of 20 k ohms/volt. No signal in.
 Voltage variations may be noted because of normal production tolerances.

TAE-8450 TAE-8450

4-19. MOUNTING DIAGRAM - I Board (Peak Program Meter) - - Conductor Side -



I Circuit Board					
Connector No.	Terminal No. of Connector	Color of Lead Wire	Conductors Sheath	Tube	To
29	1	WHT/RED		L	37
	2	RED		L	37
	3	WHT/ORG		• S27	(3)
	4	RED	GRN	• S25	(5)
	5	WHT/GRY		• S27	(5)
	6				
	7	WHT/GRN		• S27	(2)
	8	GRN		• S27	(8)
	9				
	10	GRY		• S27	(11)
	11				
	12	ORG		• S27	(9)
	13	VLT		D	20
	14	BLK		J	31
30	1	WHT	• S27	(6)	
	2	BLK	• S25	(11)	
	3	SHIELD	GRN		
	4	WHT/BRN		H	28
	5	WHT/BRN		J	31
	6	BRN		H	28
30	1	BRN		J	31
	2	BRN		J	31
	3	GRY			
	4	GRY			
	5	BLU			
	6	WHT			

• S25 and S27 show reference number of switch.

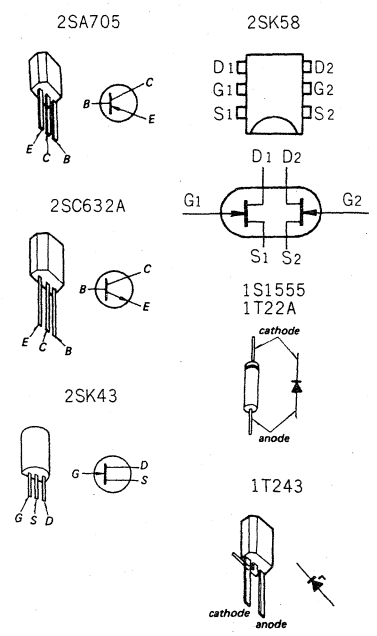
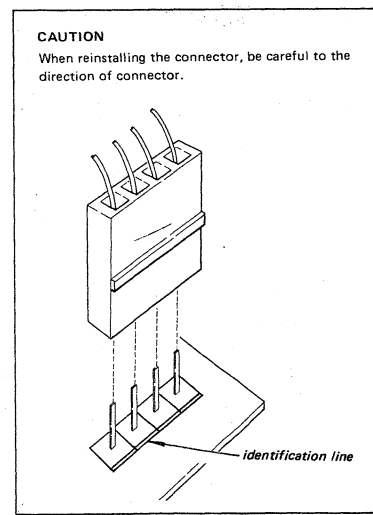
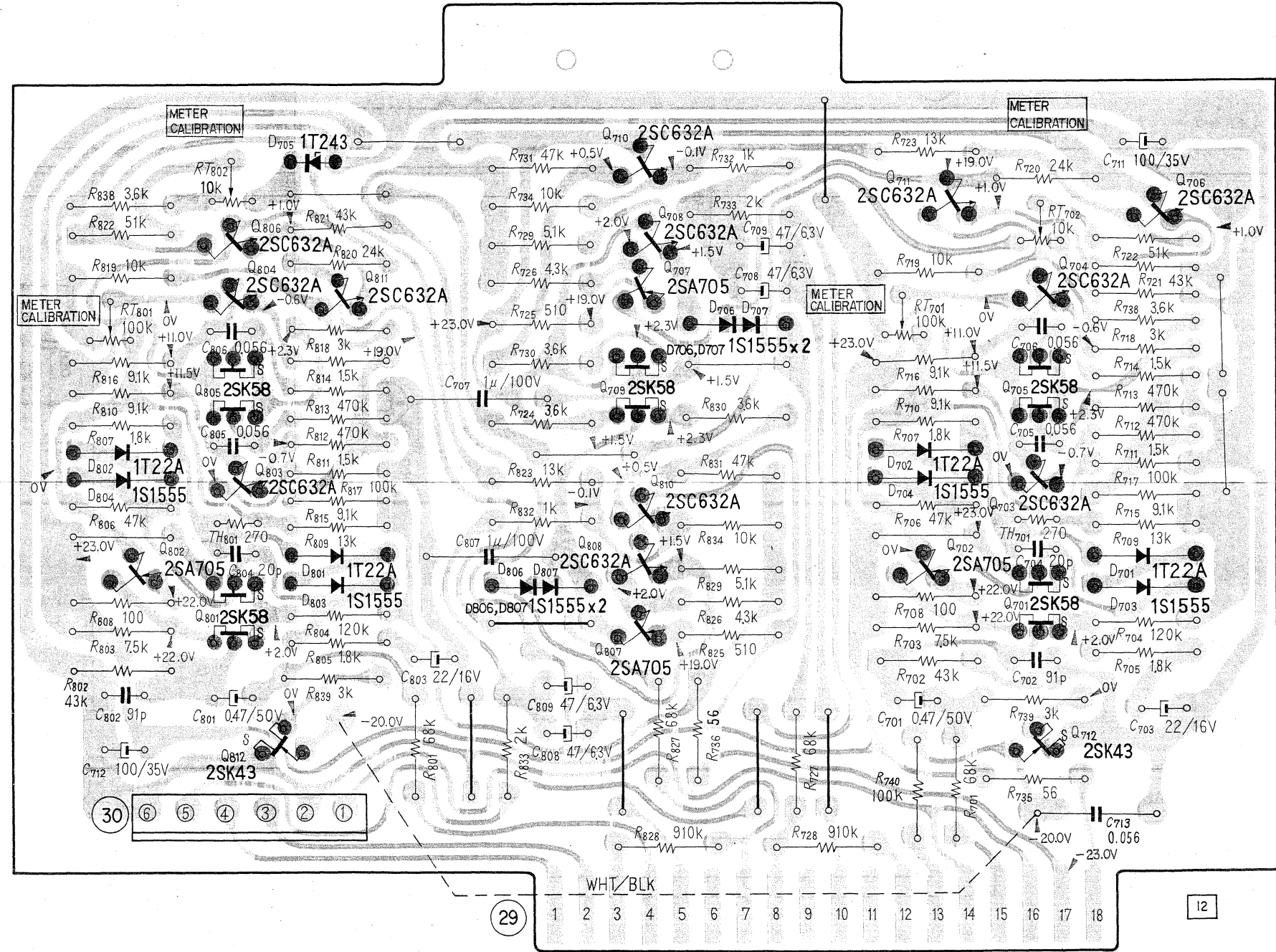

D802	Q806	D705	Q710	D706	Q711	Q706
D804	Q804		Q708			
	Q805		Q707			Q704
	Q803	D801	Q709			Q705
	Q801	D803	Q810	D806	D702	Q703
	Q802		Q808		D704	Q701
	Q812		Q807		Q702	Q712
						D701
						D703

TAE-8450 TAE-8450

4-20. SCHEMATIC DIAGRAM — I Section (Peak Program Meter) —

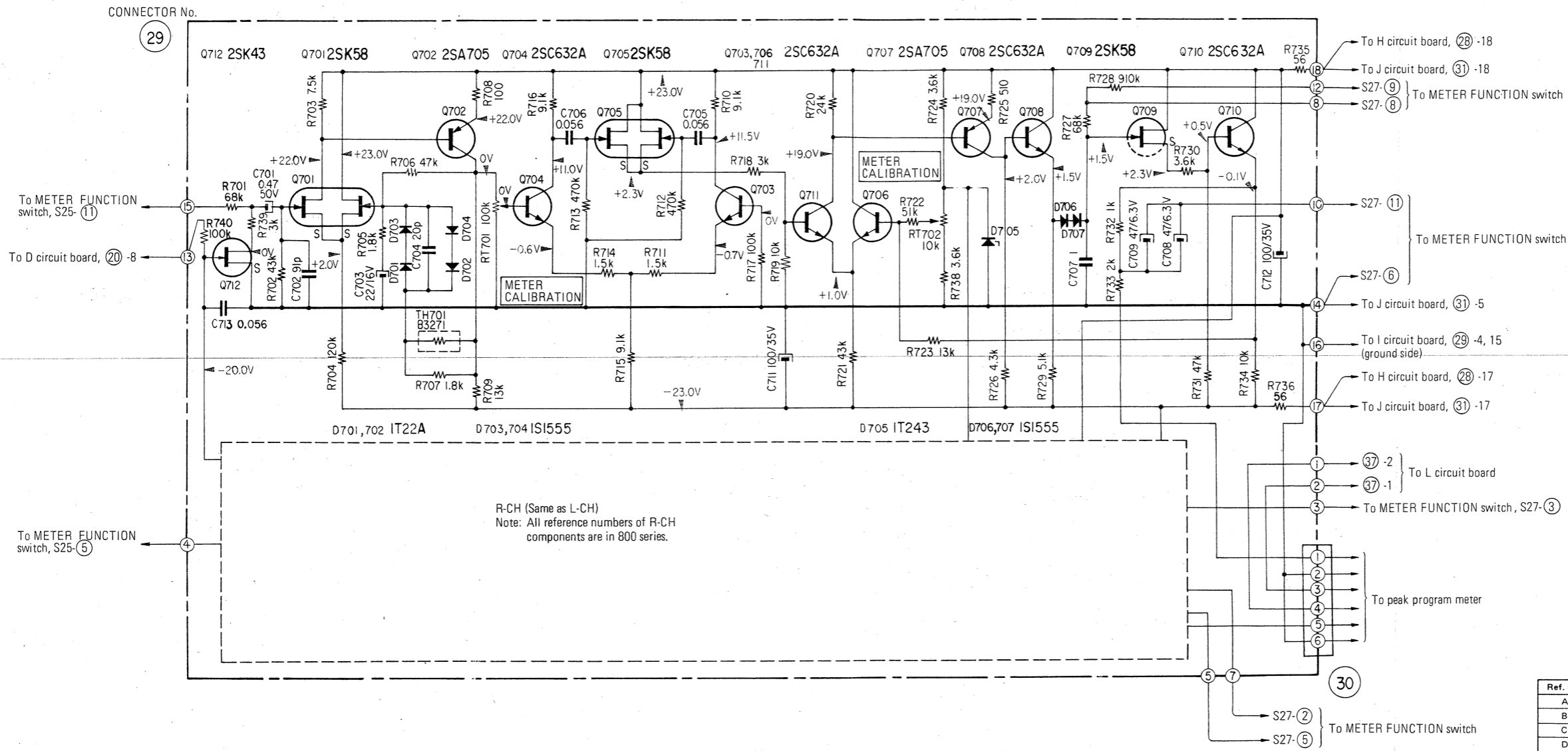

Ref. No.	Circuit Board	Page
A	Volume Control	16
B	Selector Switch	18
C	Tone Control	21
D	Filter	25
E	MIC/AUX	29
F	Equalizer	33
G	Phono Head Amp	37
H	Tone Control Amp	41
I	Peak Program Meter	45
J	MIC/Headphone Amp	49
K	Phono Jack	54
L	Power Supply	57

Note:

All resistance values are in ohms. k = 1,000 M = 1,000 k
 All capacitance values are in μF except as indicated with p, which means μM .
 All voltages are dc measured with a VOM which has an input impedance of 20 k ohms/volt. No signal in.
 Voltage variations may be noted because of normal production tolerances.

TAE-8450 TAE-8450



4-21. MOUNTING DIAGRAM – J Board (MIC/Headphone Amp) –
– Conductor Side –

J Circuit Board

Connector No.	Terminal No. of Connector	Color of Lead Wire		To		
		Conductors Sheath	Tube	Circuit Board Connector No.	Terminal No. of Connector	
31	1	WHT	YEL	D	20	15
	2	BLK		D	20	6
	3	BLK		L	38	2
	4	BLK		H	28	16
	5	BLK		I	29	14
	6	RED	YEL	D	20	13
	7	RED	GRN	D	20	10
	8	WHT	GRN	D	20	14
	9	GRY		E	21	17
	10	VLT		E	21	9
	11	WHT/VLT		E	21	8
	12	WHT/GRY		E	21	18
	13	RED	ORG	E	21	6
	14	WHT	ORG	E	21	5
	15	BLK		A	3	3
	16	SHIELD	ORG	E	21	4
		BLK		E	21	10
	17	WHT/BRN		I	29	17
	WHT/BRN		L	38	3	
18	BRN		I	29	18	
	BRN		L	38	1	

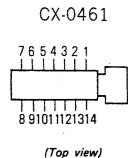
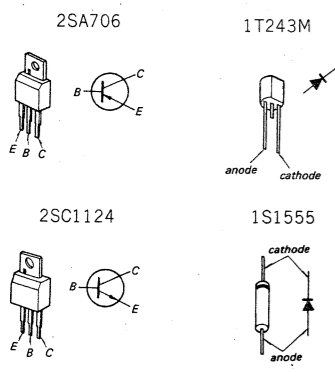
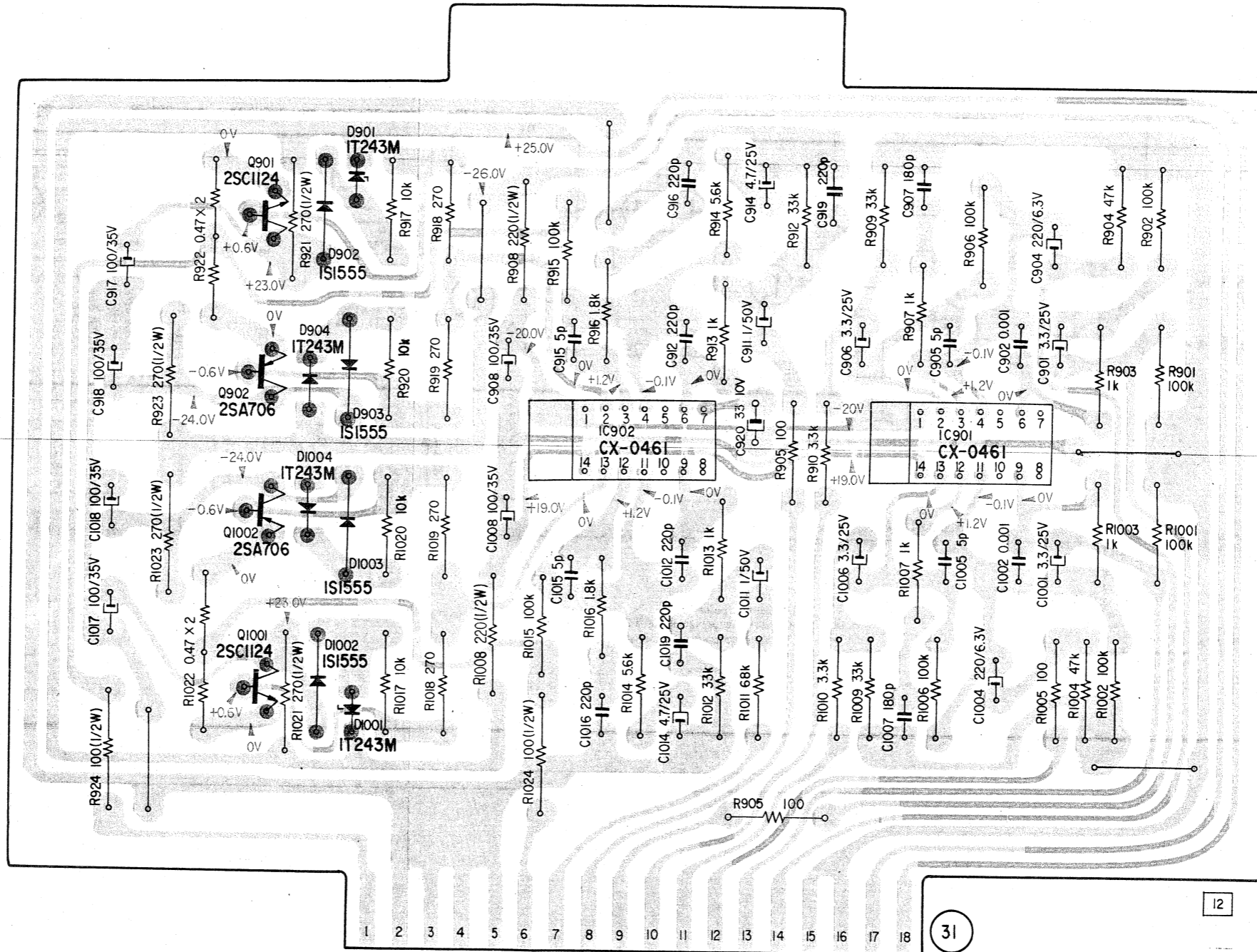

TAE-8450 TAE-8450

J J

4-22. SCHEMATIC DIAGRAM — J Section (MIC/Headphone Amp) —

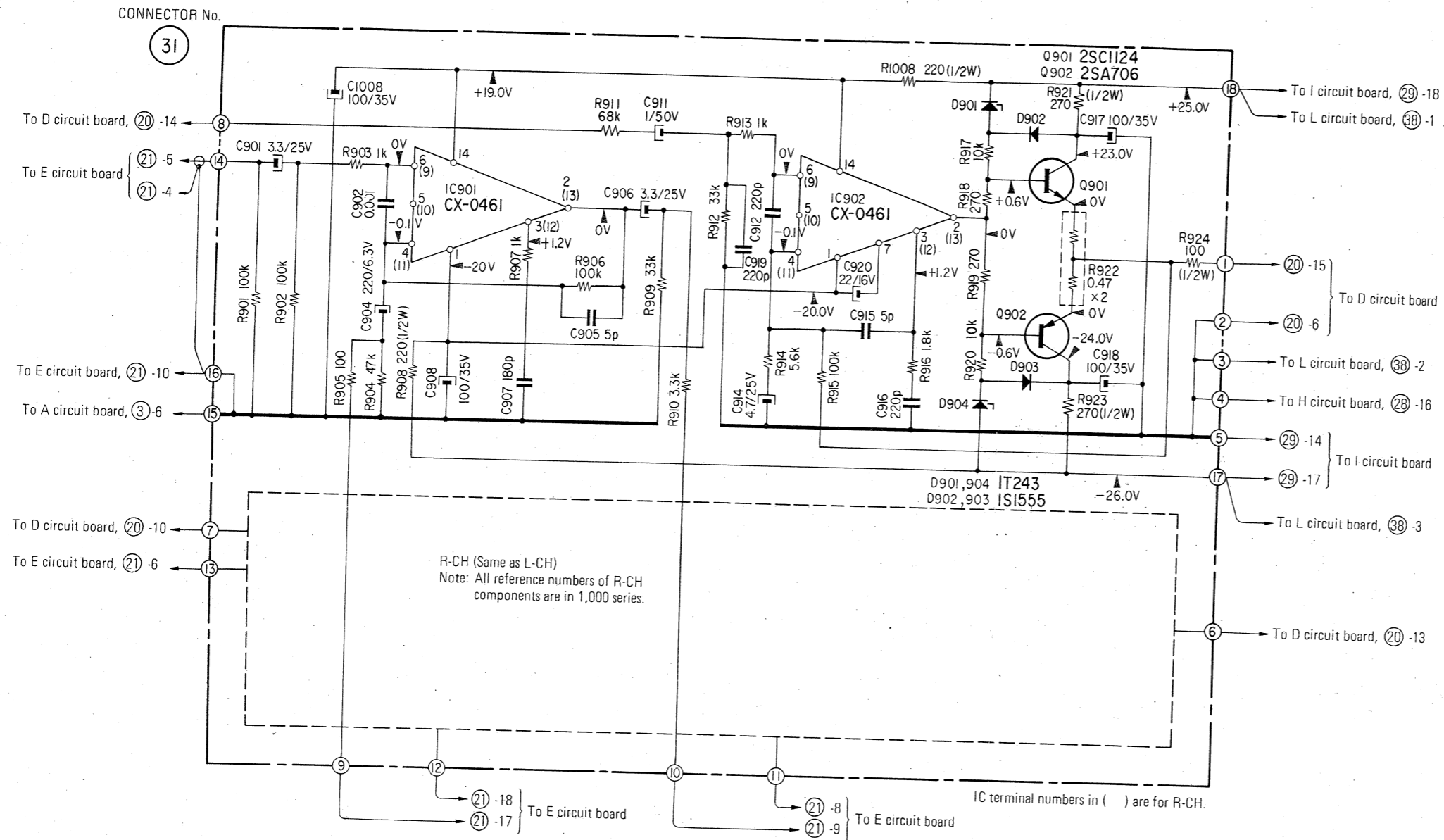

Ref. No.	Circuit Board	Page
A	Volume Control	16
B	Selector Switch	18
C	Tone Control	21
D	Filter	25
E	MIC/AUX	29
F	Equalizer	33
G	Phono Head Amp	37
H	Tone Control Amp	41
I	Peak Program Meter	45
J	MIC/Headphone Amp	49
K	Phono Jack	54
L	Power Supply	57

Note:

All resistance values are in ohms. k = 1,000 M = 1,000 k
 All capacitance values are in μ F except as indicated with p, which means $\mu\mu$ F.
 All voltages are dc measured with a VOM which has an input impedance of 20 k ohms/volt. No signal in.
 Voltage variations may be noted because of normal production tolerances.

K

4-23. MOUNTING DIAGRAM - K Board (Phono Jack) -
- Conductor Side -

K Circuit Board

Connector No.	Terminal No. of Connector	Color of Lead Wire			Connected to	
		Conductor's Sheath	Tube	Circuit Board	Connector No.	Terminal No. of Connector
32	1	WHT	ORG	D	20	5
	2	SHIELD	ORG			
	3	RED	ORG	D	20	9
	6	RED	CLEAR	D	20	17
	7	SHIELD	CLEAR			
	8	WHT	CLEAR	D	20	11
	1	WHT	ORG	C	15	3
	2	SHIELD	ORG			
33	3	RED	ORG	C	15	6
	4	BLK		B	9	3
	5	WHT/GRN		C	13	1
	6	GRN		C	13	5
	7	WHT/VLT		C	13	4
	8	VLT		C	12	4
	1	WHT	CLEAR	C	15	2
	2	SHIELD	CLEAR			
34	3	RED	CLEAR	C	15	8
	4	RED	GRN	C	14	10
	5	WHT	GRN	C	14	5
	6	SHIELD	GRN			
	8	SHIELD	YEL			
	9	WHT	YEL	C	14	2
	10	RED	YEL	C	14	6
	1	RED	GRN	C	10	5
35	2	WHT	GRN	C	10	3
	3	SHIELD	GRN			
	4	RED	BLU	C	10	6
	5	WHT	BLU	C	10	2
	6	SHIELD	BLU			
	8	SHIELD	YEL			
	9	WHT	YEL	B	5	4
	10	RED	YEL	B	6	4
36	1	WHT/ORG		G	26	7
	2	ORG		G	26	1
	3	YEL		G	26	2
	5	WHT/YEL		G	26	8
	6	BLK		G	26	5
	7	RED		G	26	3
	8	WHT/RED		G	26	9

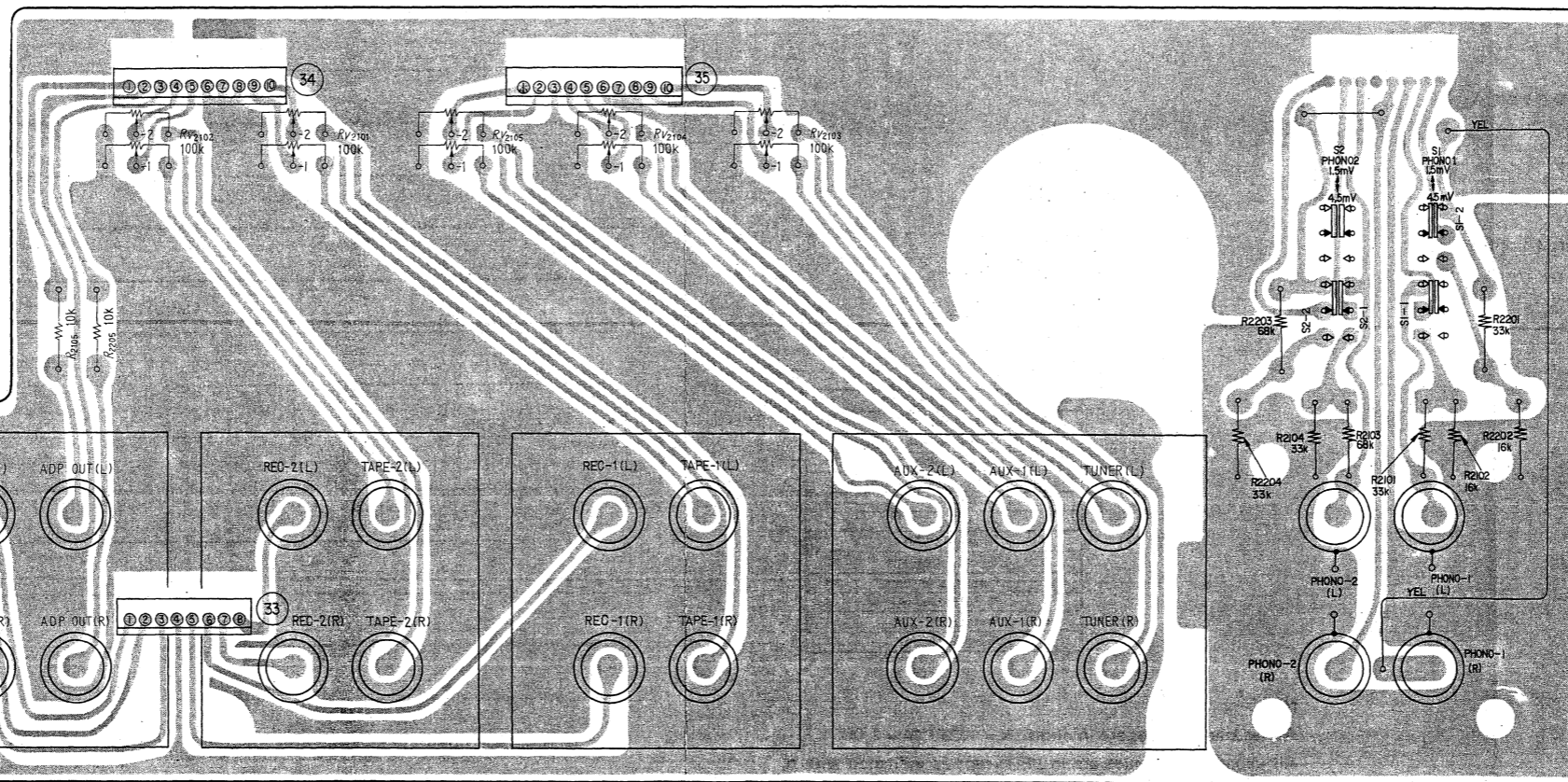
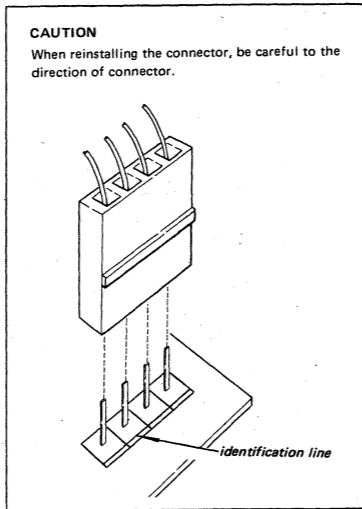

4-24. SCHEMATIC DIAGRAM
- K Section (Phono Jack) -

K

K

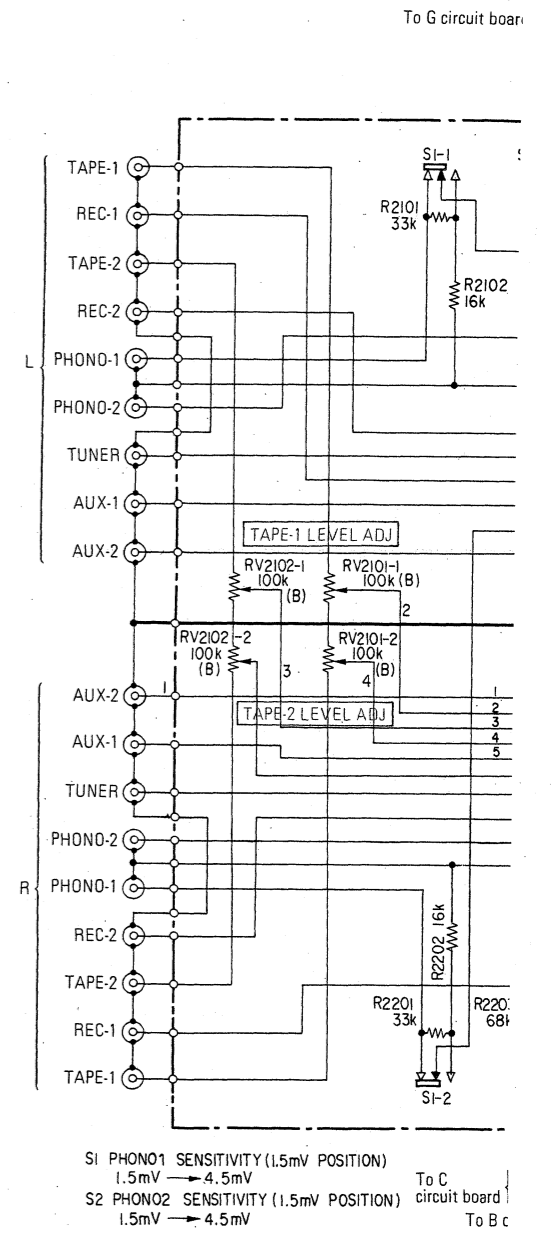

4-24. SCHEMATIC DIAGRAM
 - K Section (Phono Jack) -

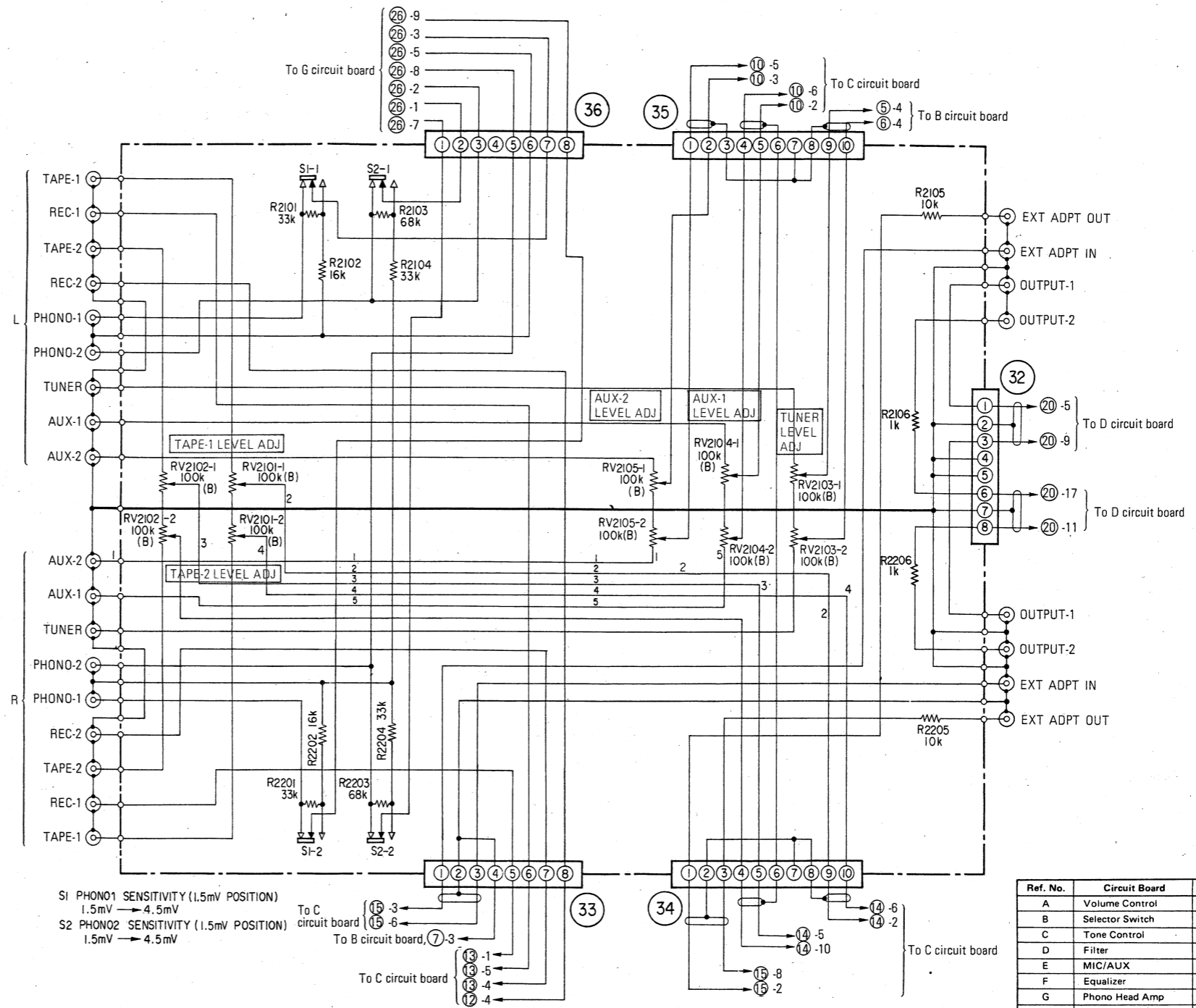
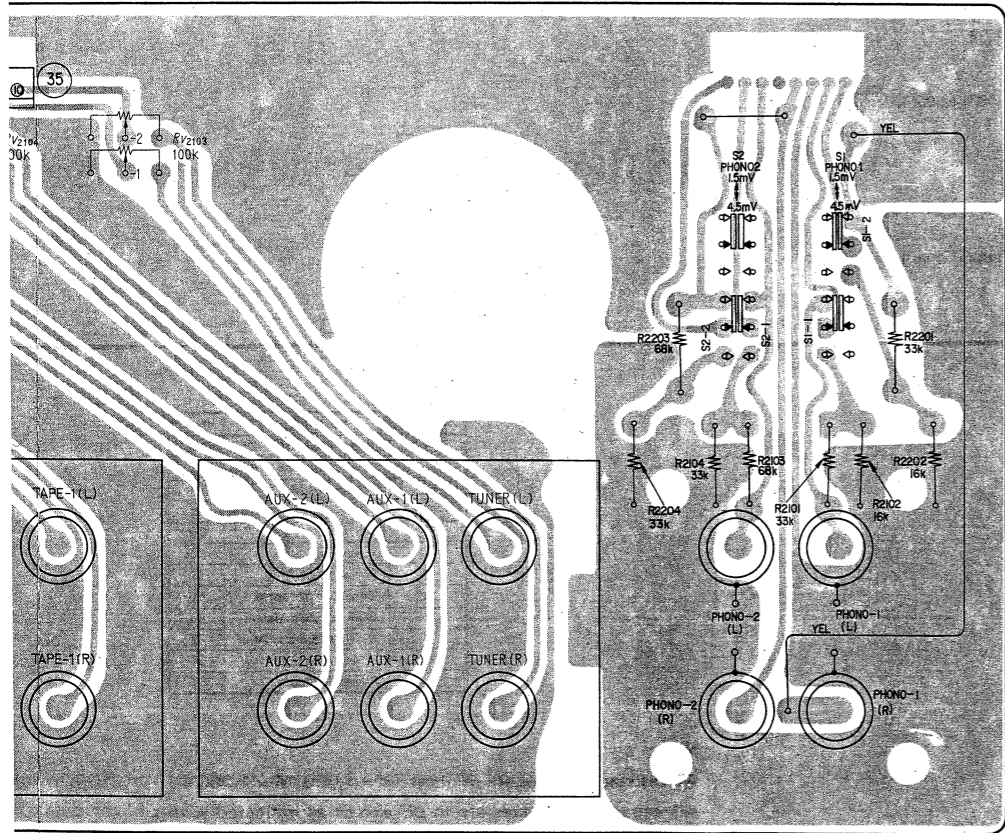
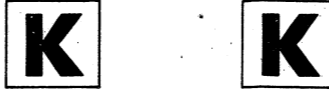

S1 PHONO1 SENSITIVITY (1.5mV POSITION)
 1.5mV → 4.5mV
 S2 PHONO2 SENSITIVITY (1.5mV POSITION)
 1.5mV → 4.5mV

Ref. No.	Circuit Board	Page
A	Volume Control	16
B	Selector Switch	18
C	Tone Control	21
D	Filter	25
E	MIC/AUX	29
F	Equalizer	33
G	Phono Head Amp	37
H	Tone Control Amp	41
I	Peak Program Meter	45
J	MIC/Headphone Amp	49
K	Phono Jack	54
L	Power Supply	57

Note:
 All resistance values are in ohms. k = 1,000 M = 1,000 k

TAE-8450 TAE-8450



4-25. MOUNTING DIAGRAM - L Board (Power Supply) -
- Conductor Side -

USA Model
(Serial No. up to 800, 140)

L Circuit Board					
Connector No.	Terminal No. of Connector	Color of Lead Wire	Conductor's Sheath	Tube	Connected to
37	1	RED			29
	2	WHT/RED			29
	3	BLU			TERMINAL STRIP
	4	BLU			TERMINAL STRIP
38	1	BRN			J 31
	2	BLK			J 31
	3	WHT/BRN			J 31
	4	WHT/BLK			D 20

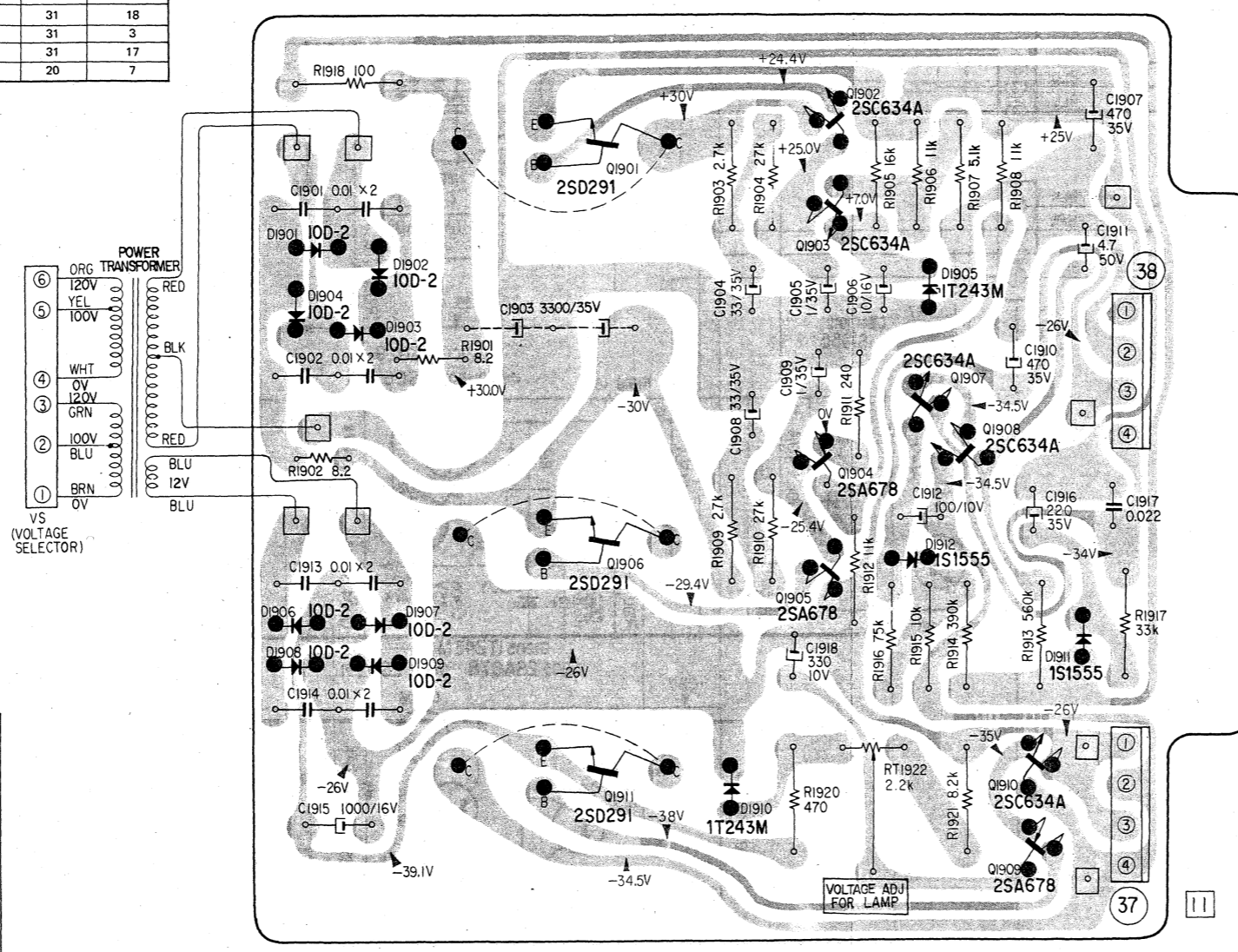
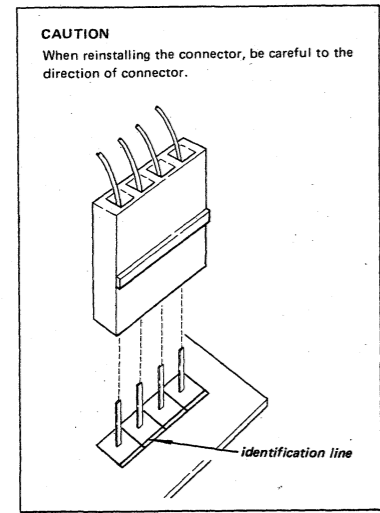
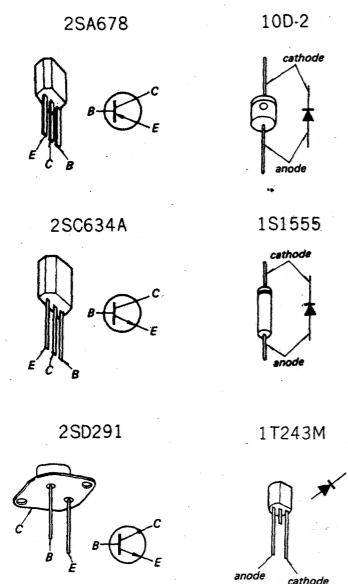

- Q1902
- Q1901
- D1901
- Q1903
- D1905
- D1904
- Q1907
- Q1908
- Q1904
- D1912
- Q1906
- Q1905
- D1906
- D1907
- D1908
- D1909
- D1911
- Q1910
- Q1911
- D1910
- Q1909

4-26. SCHEMATIC DIAGRAM - L Section (Power Supply) -

USA Model
(Serial

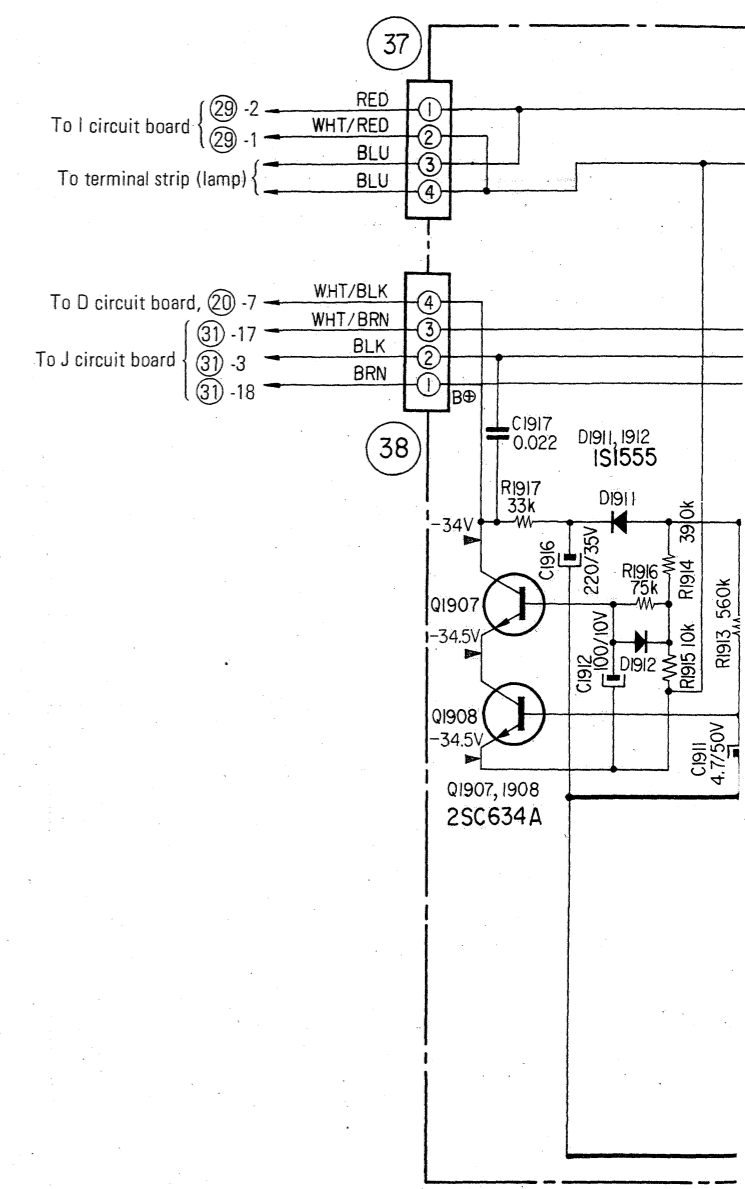

4-26. SCHEMATIC DIAGRAM - L Section (Power Supply) -

USA Model
(Serial No. up to 800, 140)

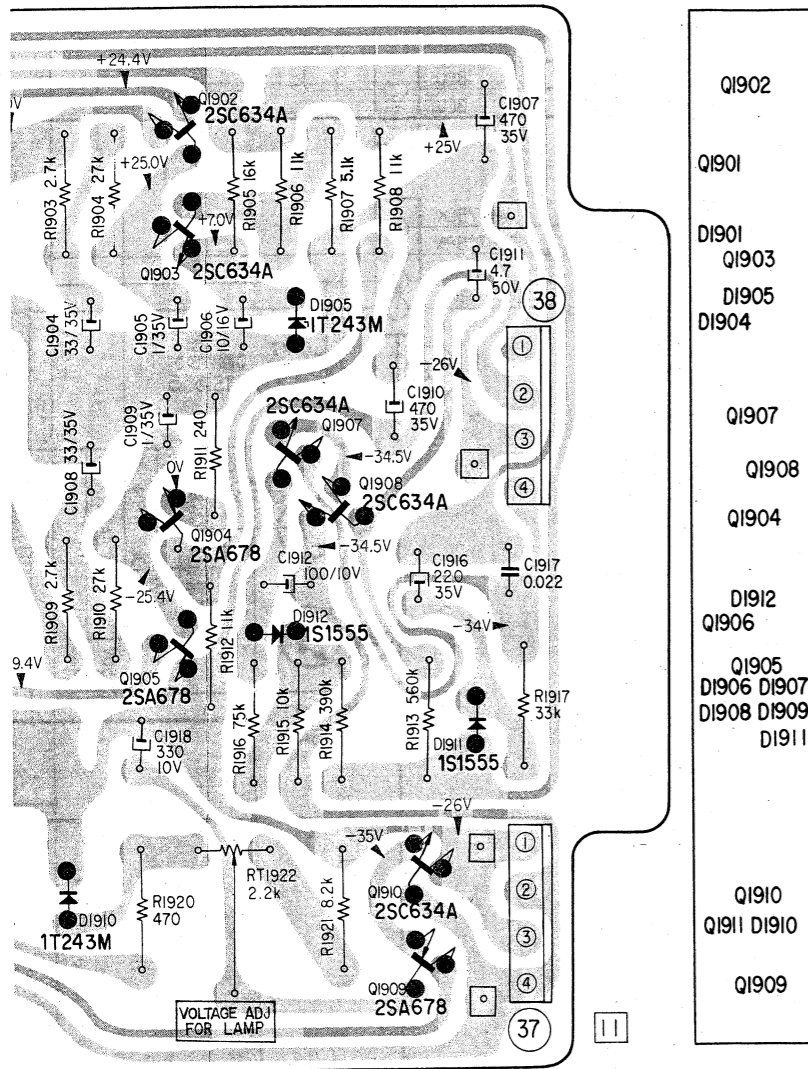

- Q1902
- Q1901
- D1901
- Q1903
- D1905
- D1904
- Q1907
- Q1908
- Q1904
- D1912
- Q1906
- Q1905
- D1906
- D1907
- D1908
- D1909
- D1911
- Q1910
- Q1911
- D1910
- Q1909

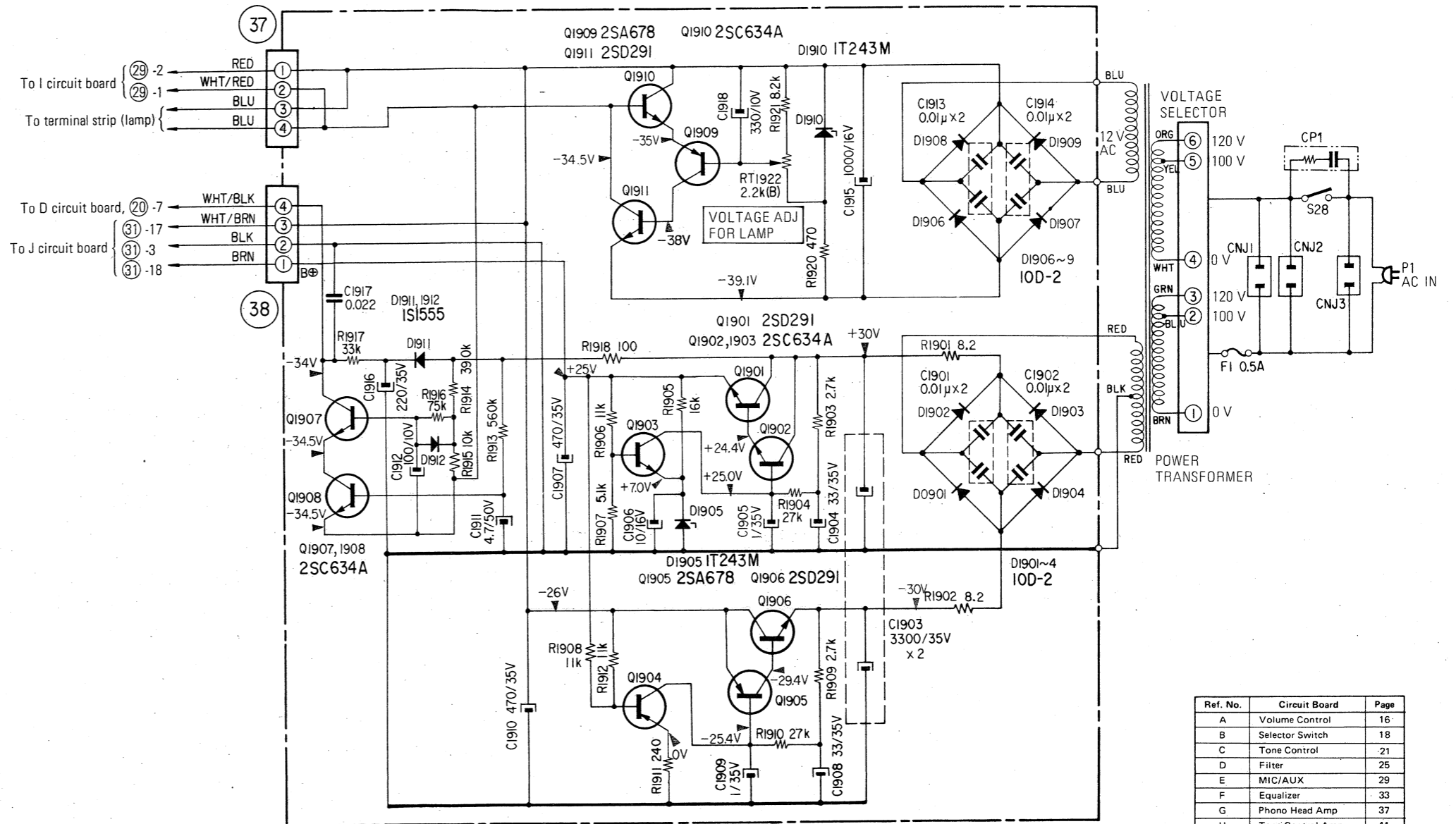

Ref. No.	Circuit Board	Page
A	Volume Control	16
B	Selector Switch	18
C	Tone Control	21
D	Filter	25
E	MIC/AUX	29
F	Equalizer	33
G	Phono Head Amp	37
H	Tone Control Amp	41
I	Peak Program Meter	45
J	MIC/Headphone Amp	49
K	Phono Jack	54
L	Power Supply	57

Note:

All resistance values are in ohms. k = 1,000 M = 1,000 k
 All capacitance values are in μF except as indicated with p, which means μM .
 All voltages are dc measured with a VOM which has an input impedance of 20 k ohms/volt. No signal in.
 Voltage variations may be noted because of normal production tolerances.



USA Model
(Serial No. 800, 141 and later)
AEP Model



SCHEMATIC DIAGRAM - L Section (Power Supply) -

4-27. MOUNTING DIAGRAM - L Board (Power Supply) -
- Conductor Side -
L Circuit Board

Connector No.	Terminal No. of Connector	Color of Lead Wire	Conductors Sheath	Tube	Circuit Board	Connector No.	To	Terminal No. of Connector
37	1	RED			I	29	2	
	2	WHT/RED			I	29	1	
	3	BLU			TERMINAL STRIP			
	4	BLU			TERMINAL STRIP			
38	1	BRN			J	31	18	
	2	BLK			J	31	3	
	3	WHT/BRN			J	31	17	
	4	WHT/BLK			D	20	7	

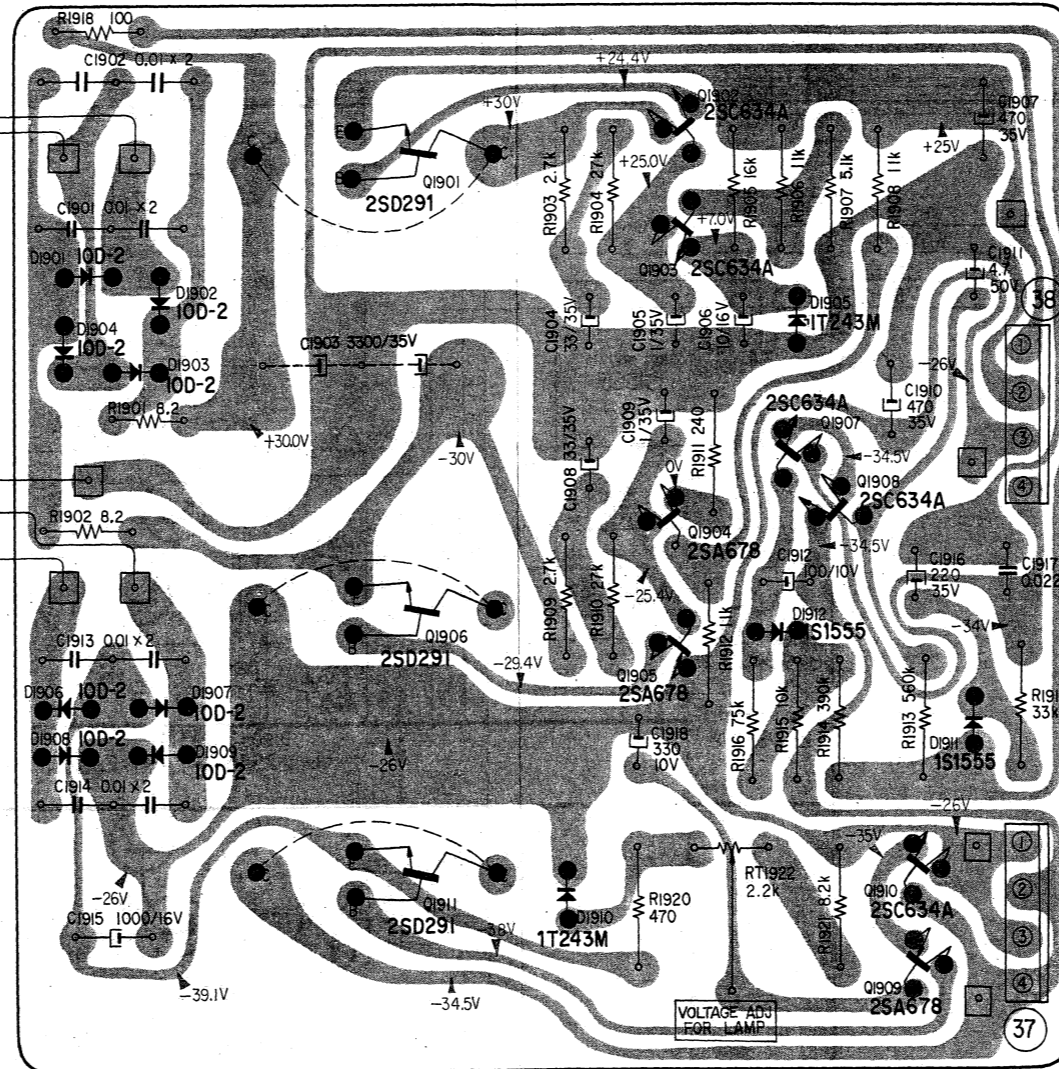
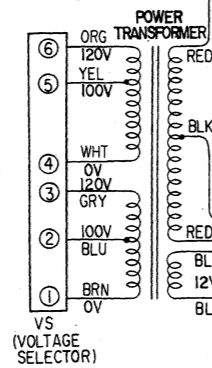
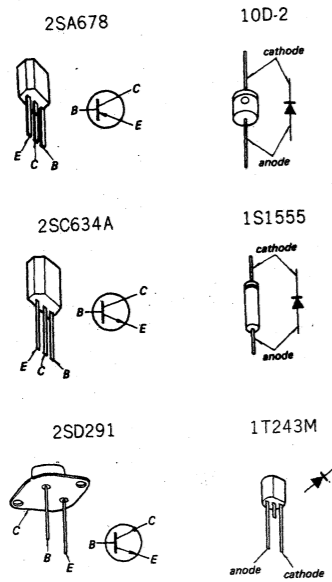

- Q1902
- Q1901
- D1901
- Q1903
- D1905
- D1904
- Q1907
- Q1908
- Q1904
- D1912
- Q1906
- Q1905
- D1906
- D1907
- D1908
- D1909
- D1911
- Q1910
- Q1911
- D1910
- Q1909

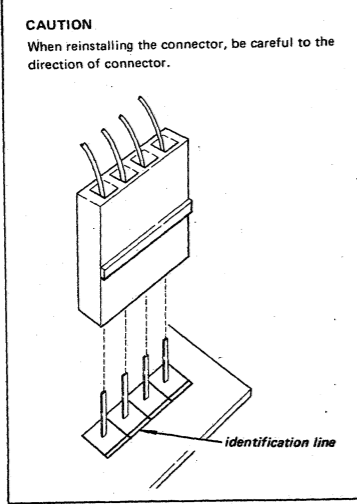
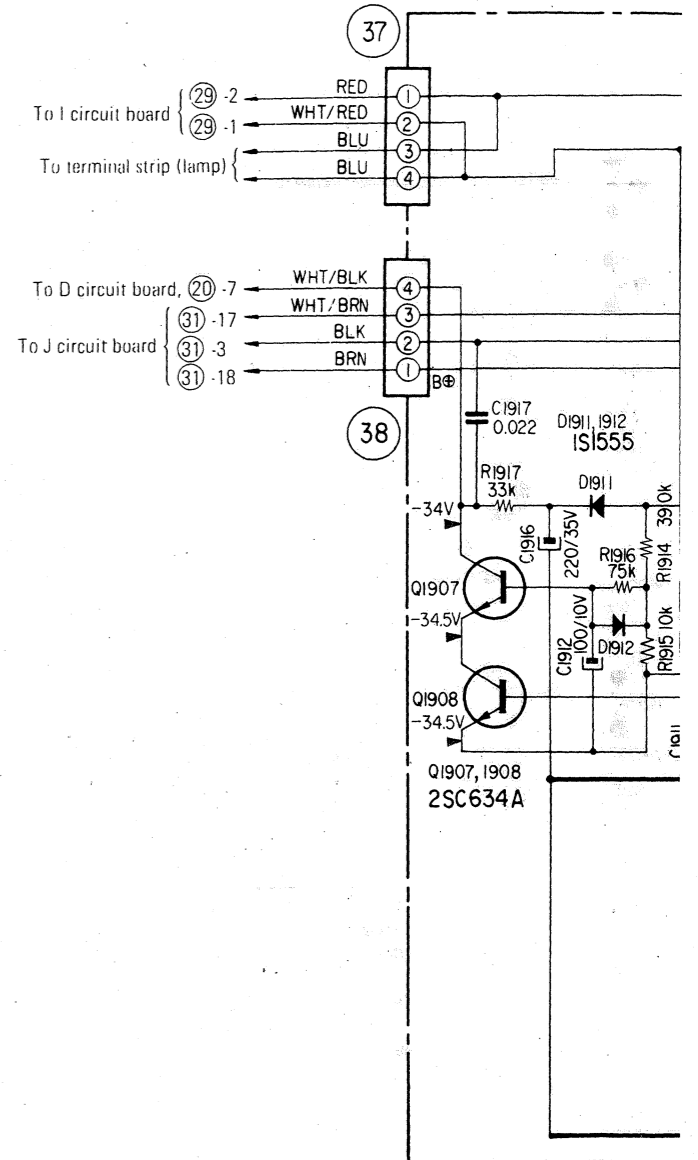

Note:
All resistance values are in ohms. k = 1,000 M = 1,000 k.
All capacitance values are in μ F except as indicated with p, which means μ μ F.
All voltages are dc measured with a VOM which has an input impedance of 20 k ohms/volt. No signal in.
Voltage variations may be noted because of normal production tolerances.

id later)

TAE-8450 TAE-8450



USA Model
(Serial No. 800, 141 and later)
AEP Model

SCHEMATIC DIAGRAM — L Section (Power Supply) —

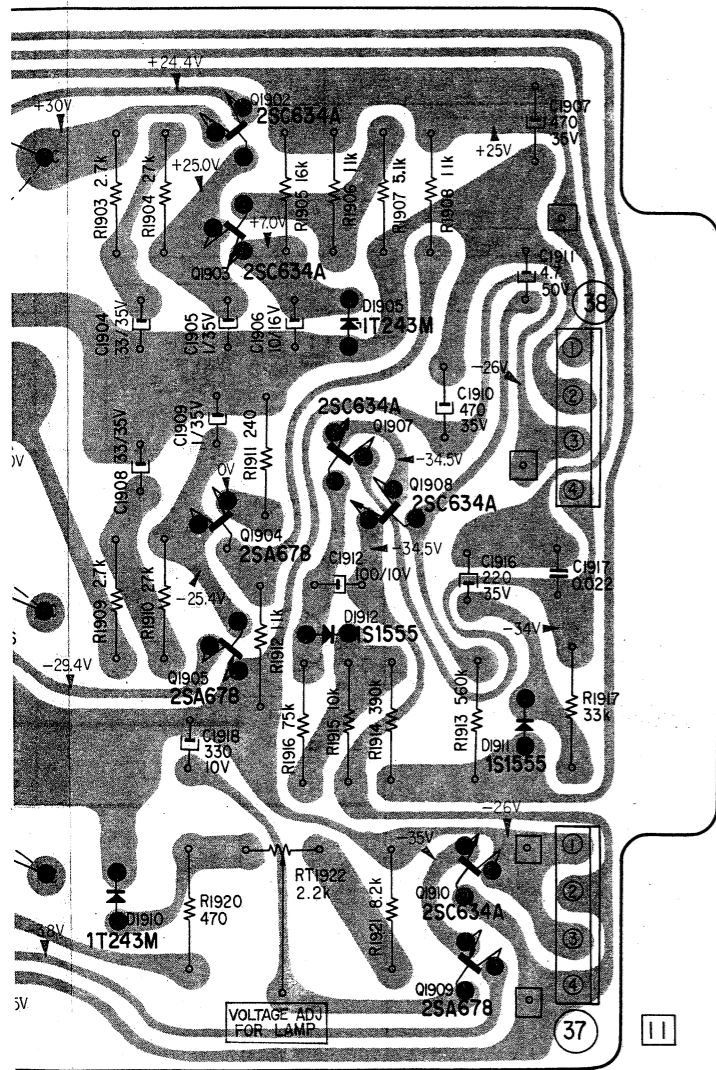

- Q1902
- Q1901
- D1901
- Q1903
- D1905
- D1904
- Q1907
- Q1908
- Q1904
- D1912
- Q1906
- Q1905
- D1906 D1907
- D1908 D1909
- D1911
- Q1910
- Q1911 D1910
- Q1909

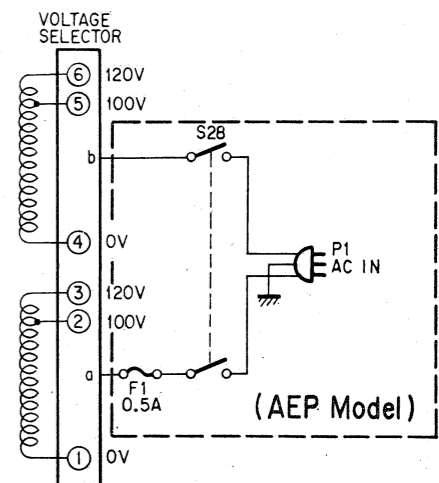
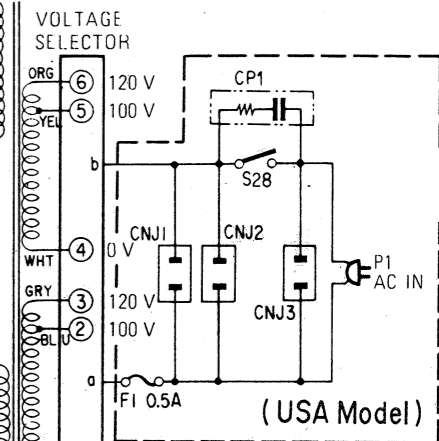
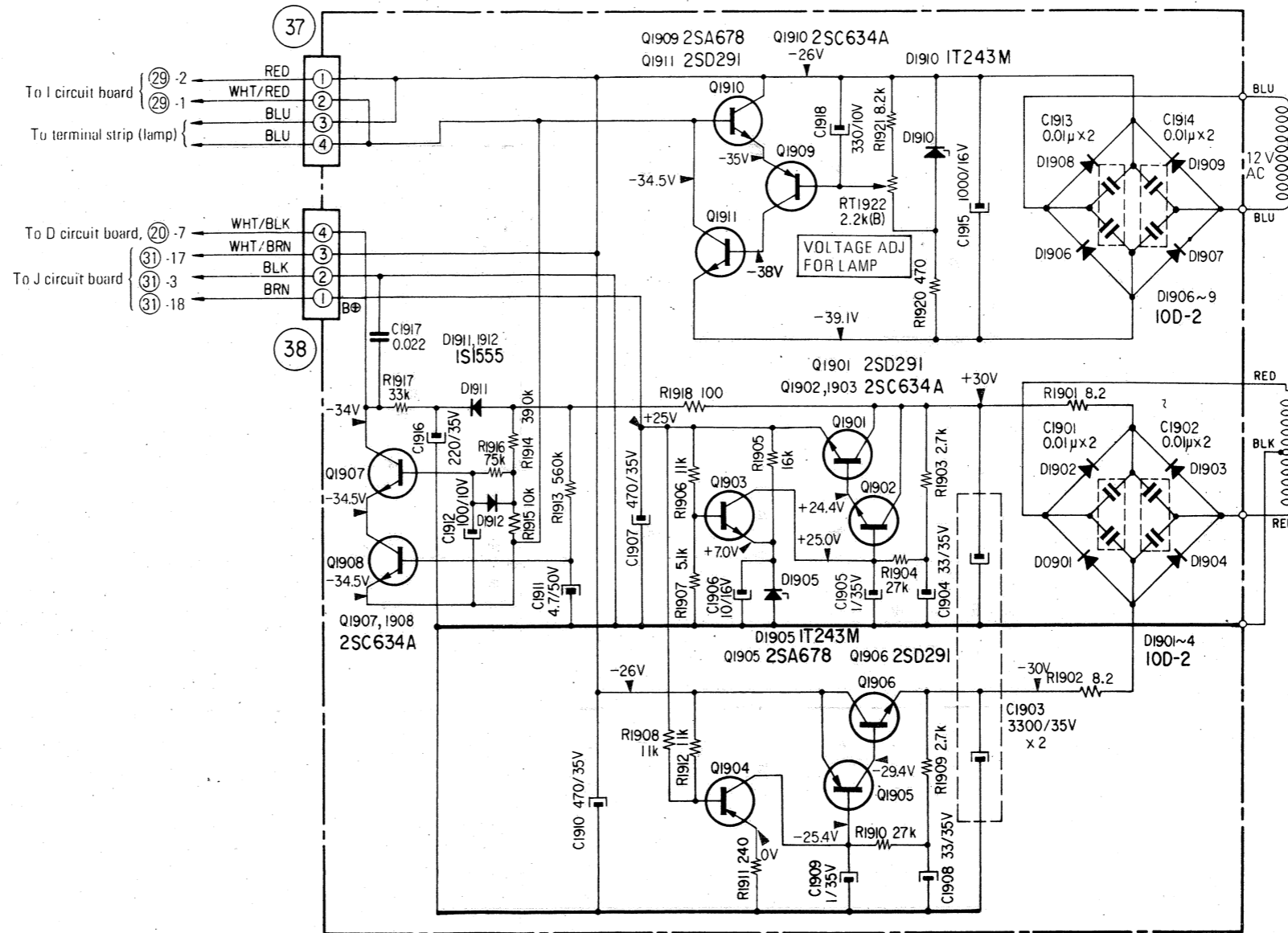

Note:
All resistance values are in ohms. k = 1,000 M = 1,000 k.
All capacitance values are in μ F except as indicated with p, which means μ F.
All voltages are dc measured with a VOM which has an input impedance of 20 k ohms/volt. No signal in.
Voltage variations may be noted because of normal production tolerances.

Ref. No.	Circuit Board	Page
A	Volume Control	16
B	Selector Switch	19
C	Tone Control	21
D	Filter	25
E	MIC/AUX	29
F	Equalizer	33
G	Phono Head Amp	37
H	Tone Control Amp	41
I	Peak Program Meter	45
J	MIC/Headphone Amp	49
K	Phono Jack	54
L	Power Supply	57

4-28. WIRING DIAGRAM

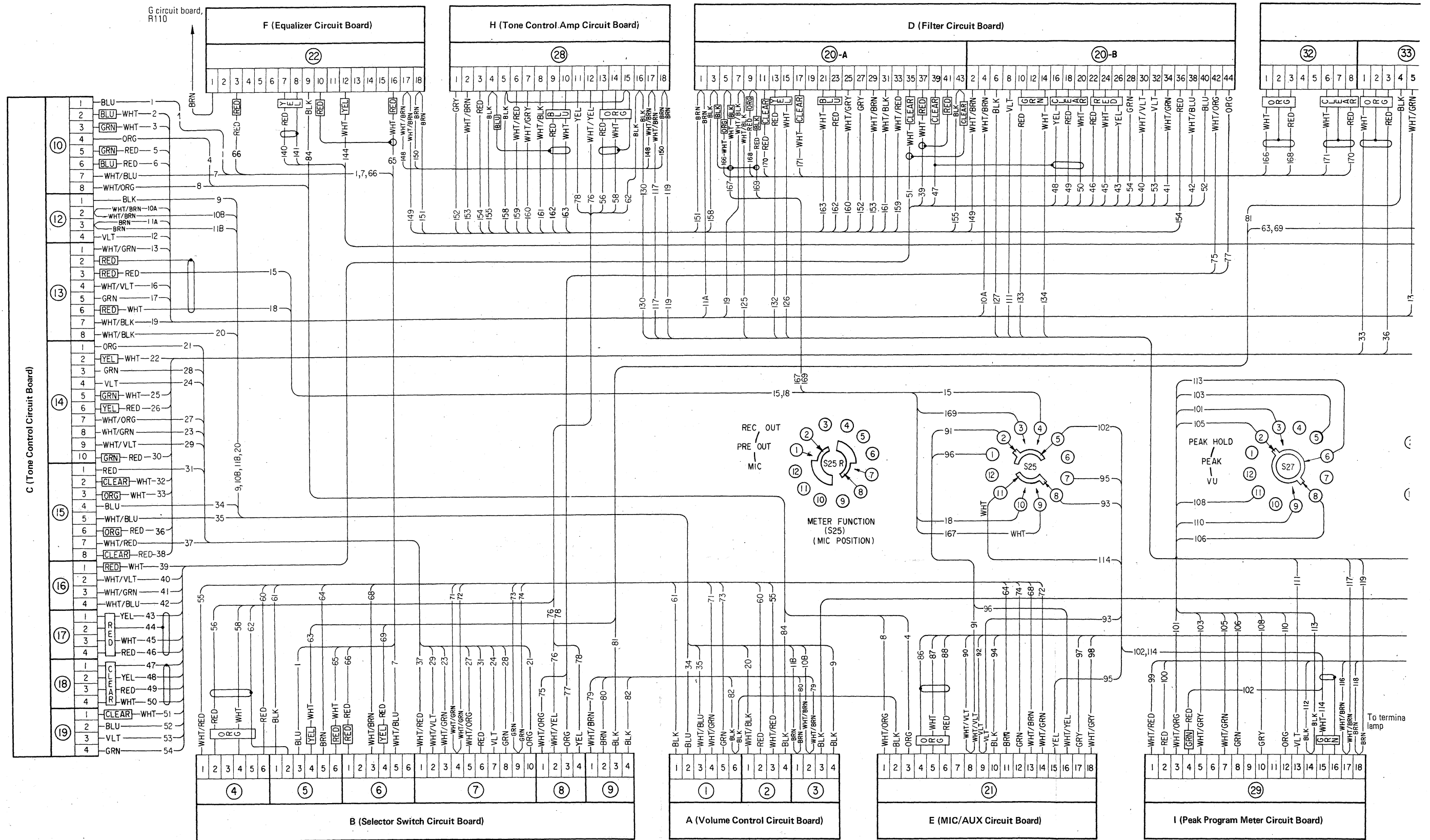

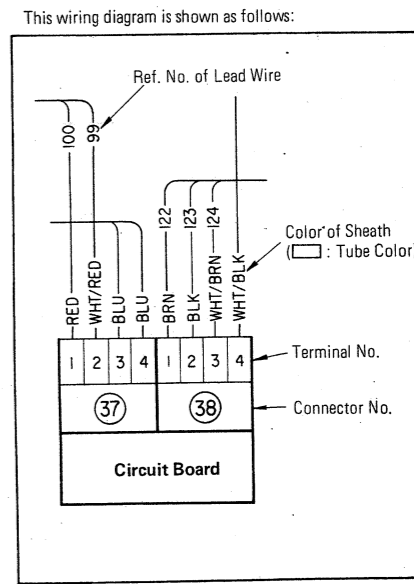
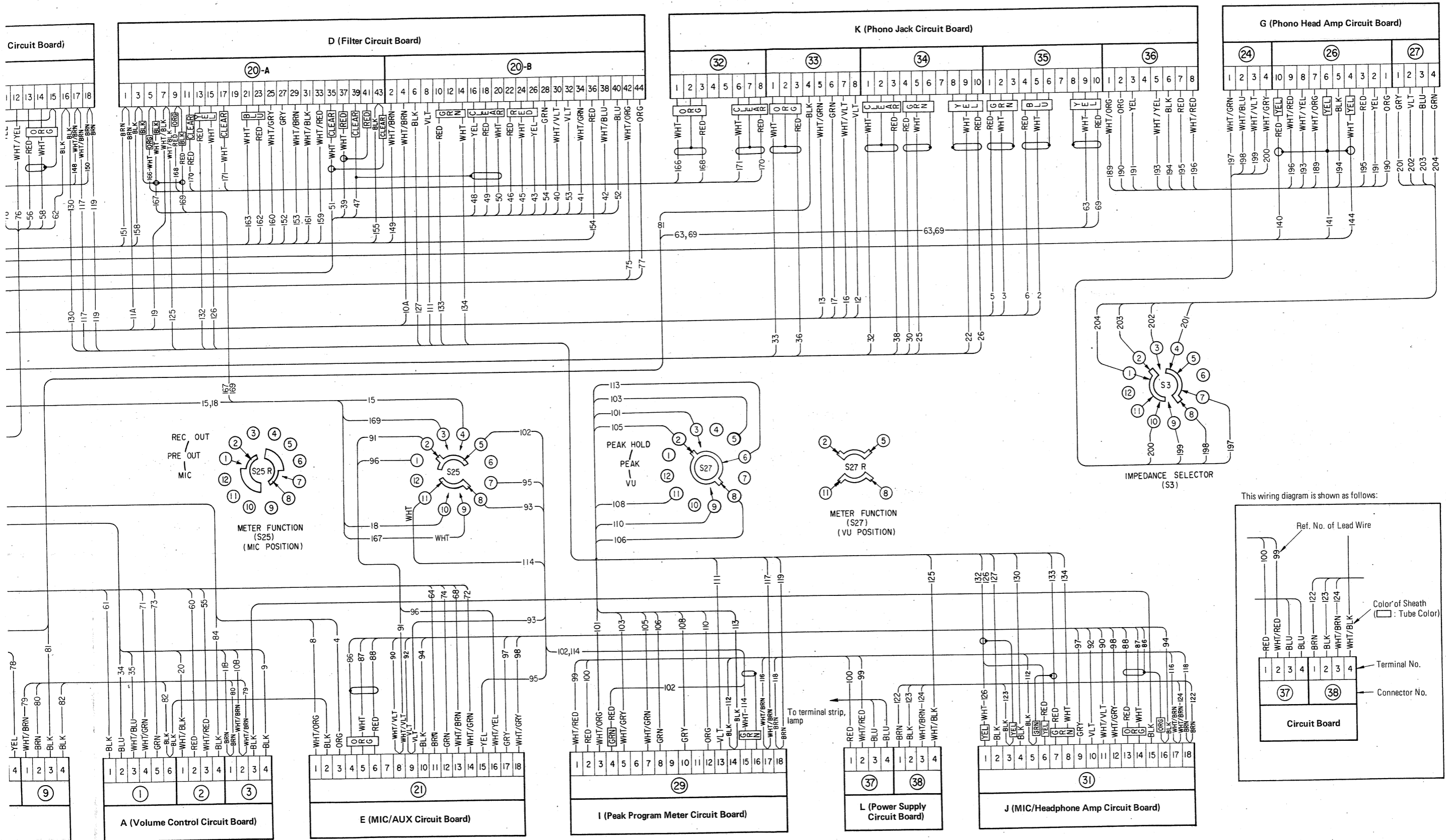

TAE-8450 TAE-8450

**SECTION 5
EXPLODED VIEWS**

(1)

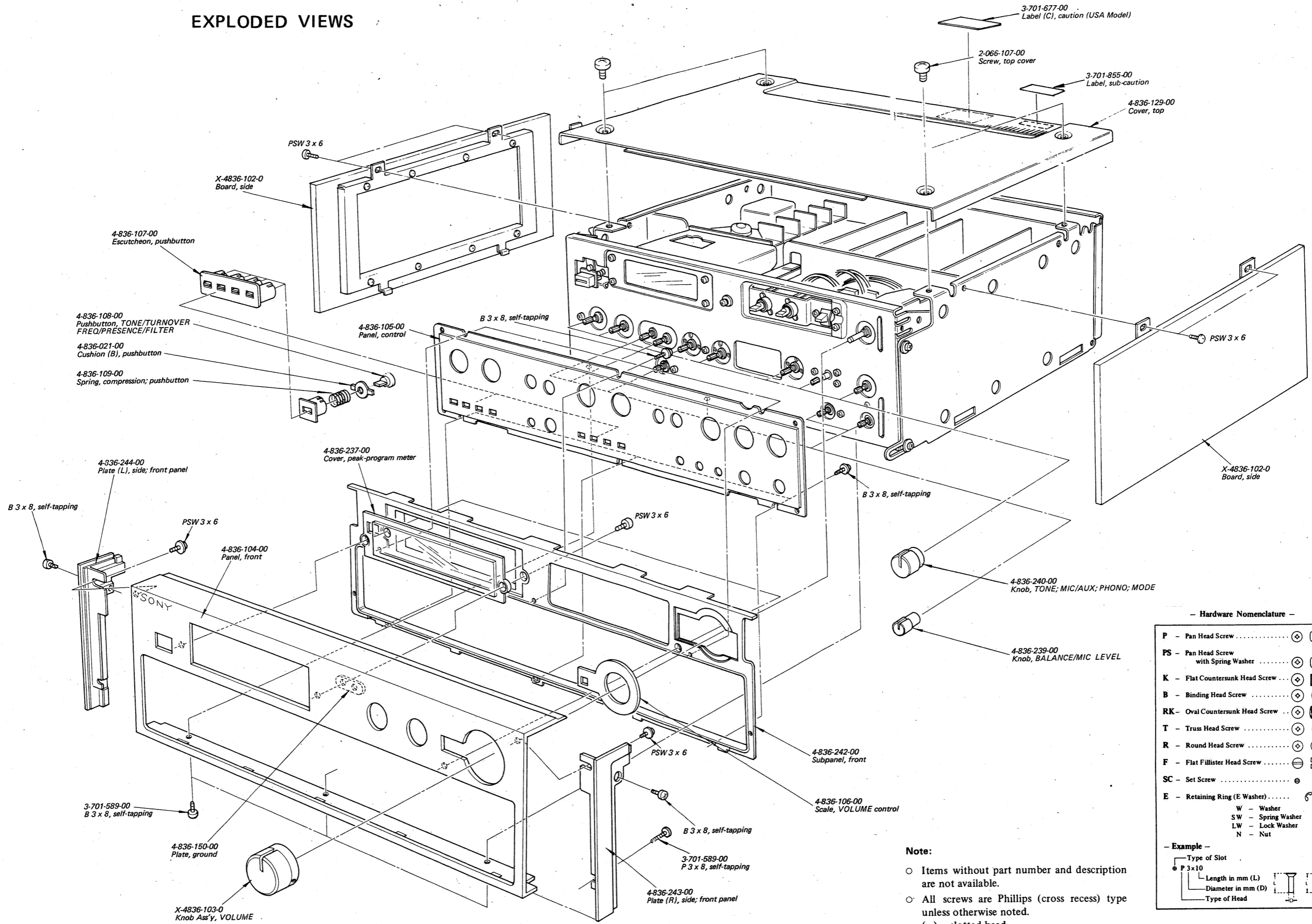

Hardware Nomenclature

P	Pan Head Screw	
PS	Pan Head Screw with Spring Washer	
K	Flat Countersunk Head Screw	
B	Binding Head Screw	
RK	Oval Countersunk Head Screw	
T	Truss Head Screw	
R	Round Head Screw	
F	Flat Filler Head Screw	
SC	Set Screw	
E	Retaining Ring (E Washer)	
	W - Washer	
	SW - Spring Washer	
	LW - Lock Washer	
	N - Nut	

Example

Type of Slot:

Length in mm (L):

Diameter in mm (D):

Type of Head:

Note:

- Items without part number and description are not available.
- All screws are Phillips (cross recess) type unless otherwise noted.
- (-) = slotted head

MEMO

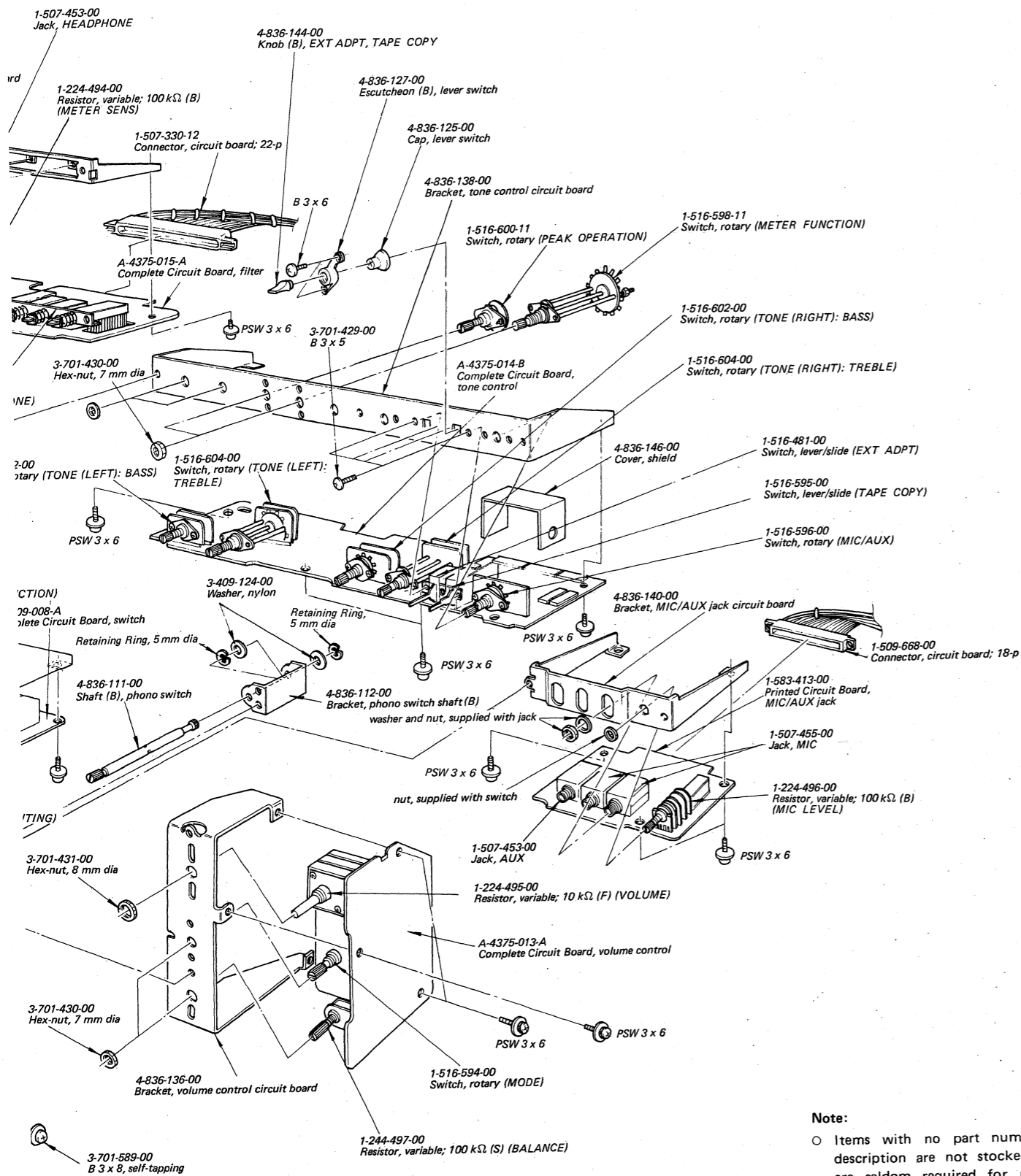

Note:

- Items with no part number and/or no description are not stocked because they are seldom required for routine service.
- All screws are Phillips (cross recess) type unless otherwise noted.
- (-) = slotted head

TAE-8450 TAE-8450

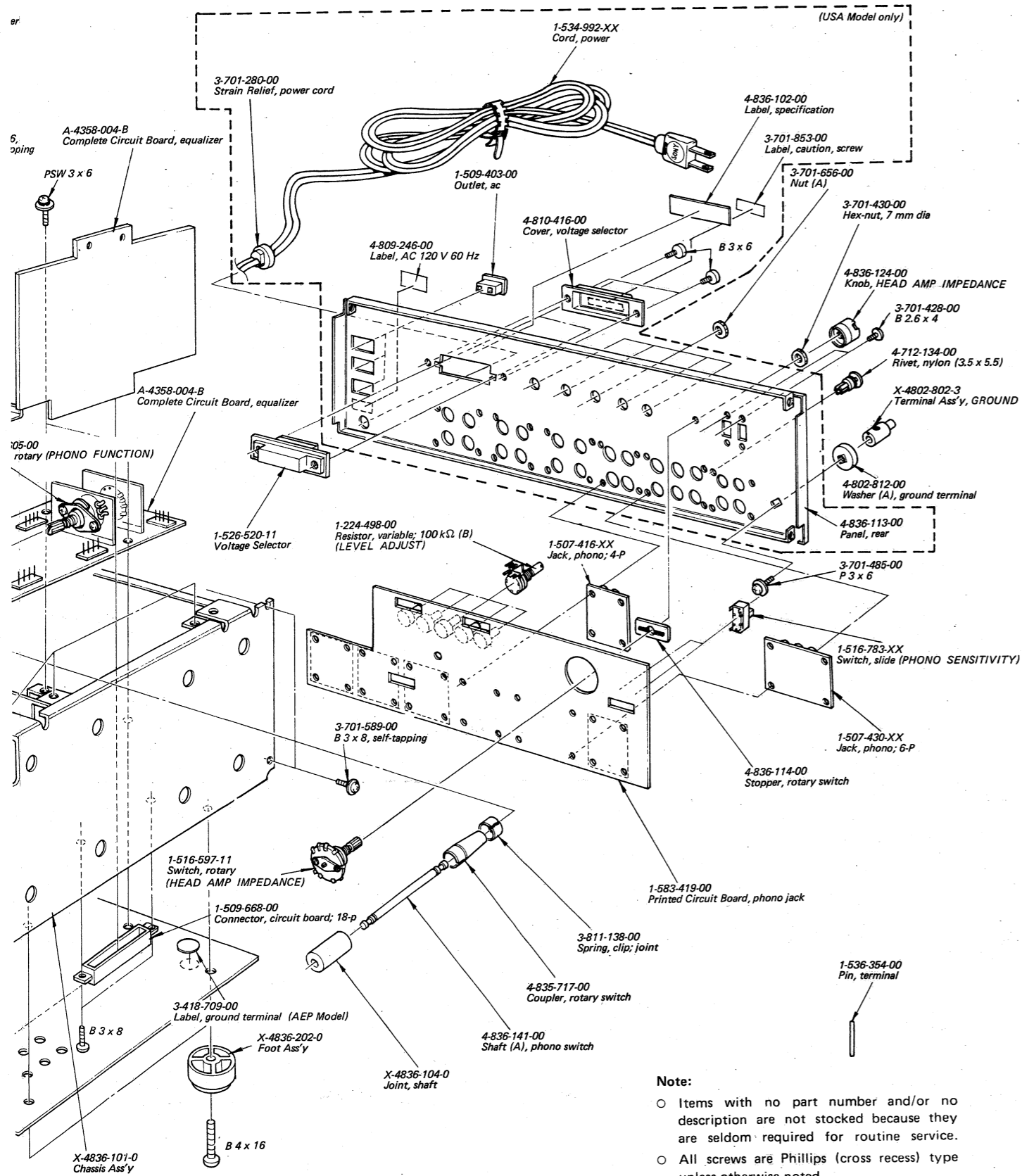

Note:

- Items with no part number and/or no description are not stocked because they are seldom required for routine service.
- All screws are Phillips (cross recess) type unless otherwise noted.
- (-) = slotted head

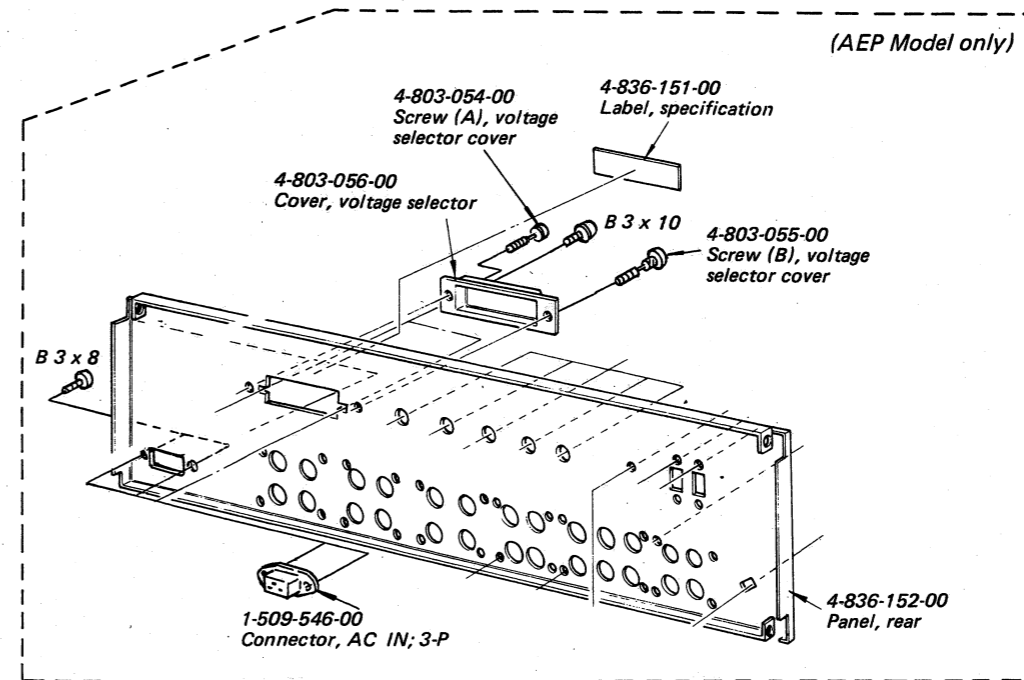

SECTION 6
ELECTRICAL PARTS LIST

Ref. No.	Part No.	Description	Ref. No.	Part No.	Description	Ref. No.	Part No.	Description	Ref. No.	Part No.	Description	
CIRCUIT BOARDS			Q505(Q605)	Transistor	2SA705	Q1701(Q1801)	FET	2SK43	D1912		Diode	1S1555
A-4358-004-B	Equalizer, complete		Q506(Q606)	Transistor	2SA705	Q1702(Q1802)	FET	2SK43	Th701	1-800-349-00	Thermistor	
A-4358-005-A	Head Amp, complete		Q507(Q607)	FET	2SK23A	Q1703(Q1803)	FET	2SK43	(Th801)			
A-4363-005-A	Mic./Headphone Amp, complete		Q508(Q608)	Transistor	2SA705	Q1704(Q1804)	FET	2SK43				
A-4375-013-A	Volume Control, complete		Q509(Q609)	FET	2SK43	Q1901	Transistor	2SD291				
A-4375-014-B	Tone Control, complete		Q510(Q610)	FET	2SK43	Q1902	Transistor	2SC634A				
						Q1903	Transistor	2SC634A				
						Q1904	Transistor	2SA678				
						Q1905	Transistor	2SA678				
A-4375-015-A	Filter, complete		Q511(Q611)	FET	2SK23A							
A-4375-017-A	Tone Control Amp, complete		Q512(Q612)	FET	2SK23A							
A-4394-011-A	Power Supply, complete		Q513(Q613)	Transistor	2SA705	Q1906	Transistor	2SD291				
A-4409-008-A	Selector Switch, complete		Q514(Q614)	Transistor	2SA705	Q1907	Transistor	2SC634A				
A-4409-009-A	Peak Program Meter, complete		Q515(Q615)	FET	2SK23A	Q1908	Transistor	2SC634A				
			Q516	Transistor	2SA705	Q1909	Transistor	2SA678				
1-583-413-00	MIC/AUX Jack		Q701(Q801)	FET	2SK58	Q1910	Transistor	2SC634A				
1-583-419-00	Phono Jack		Q702(Q802)	Transistor	2SA705	Q1911	Transistor	2SD291				
			Q703(Q803)	Transistor	2SC632A							
			Q704(Q804)	Transistor	2SC632A	IC901	IC	CX-0461				
			Q705(Q805)	FET	2SK58	IC902	IC	CX-0461				
			Q706(Q806)	Transistor	2SC632A	D101	Diode	1T243M				
			Q707(Q807)	Transistor	2SA705	D102	Diode	1T243M				
			Q708(Q808)	Transistor	2SC632A							
			Q709	FET	2SK58	D301(D401)	Diode	VD-1221				
			Q710(Q810)	Transistor	2SC632A	D701(D801)	Diode	1T22A				
						D702(D802)	Diode	1T22A				
			Q711(Q811)	Transistor	2SC632A	D703(D803)	Diode	1S1555				
			Q712(Q812)	FET	2SK43	D704(D804)	Diode	1S1555				
						D705	Diode	1T243				
			Q901(Q1001)	Transistor	2SC1124	D706(D806)	Diode	1S1555				
			Q902(Q1002)	Transistor	2SA706							
						D901(D1001)	Diode	1T243				
			Q1101(Q1201)	Transistor	2SC632A	D902(D1002)	Diode	1S1555				
			Q1102(Q1202)	Transistor	2SA705	D903(D1003)	Diode	1S1555				
						D904(D1004)	Diode	1T243				
			Q1110(Q1210)	FET	2SK23A							
			Q1111(Q1211)	Transistor	2SC632A	D1110	Diode	VD-1221				
			Q1301(Q1401)	Transistor	2SC632A	D1501	Diode	VD-1221				
			Q1501(Q1601)	FET	2SK23A	D1901 ~ D1904	Diode	10D-2				
			Q1502(Q1602)	Transistor	2SC632A	D1905	Diode	1T243M				
			Q1503(Q1603)	FET	2SK23A	D1906 ~ D1909	Diode	10D-2				
			Q1504(Q1604)	Transistor	2SC632A	D1910	Diode	1T243M				
						D1911	Diode	1S1555				
Q101(Q201)	Transistor	2SC1637										
Q102(Q202)	Transistor	2SA705										
Q103(Q203)	Transistor	2SA705										
Q301(Q401)	FET	2SK43										
Q302(Q402)	FET	2SK43										
Q303(Q403)	FET	2SK23A										
Q304(Q404)	FET	2SK23A										
Q305(Q405)	Transistor	2SA705										
Q306(Q406)	Transistor	2SA705										
Q307(Q407)	FET	2SK23A										
Q308(Q408)	Transistor	2SA705										
Q309(Q409)	FET	2SK43										
Q310(Q410)	FET	2SK43										
Q311(Q411)	FET	2SK23A										
Q312(Q412)	FET	2SK23A										
Q313(Q413)	Transistor	2SA705										
Q314(Q414)	Transistor	2SA705										
Q315(Q415)	FET	2SK23A										
Q316(Q416)	Transistor	2SA705										
Q501(Q601)	FET	2SK43										
Q502(Q602)	FET	2SK43										
Q503(Q603)	FET	2SK23A										
Q504(Q604)	FET	2SK23A										

TRANSFORMER

1-442-333-00 Power

CAPACITORS

Capacitors listed here are 50 V, mylar type unless otherwise specified and in μF except as indicated with p (p means $\mu\mu$). elect = electrolytic

C101(C201)	1-131-197-11	3.3	16 V	tantalum
C102(C202)	1-105-661-12	0.001		
C103(C203)	1-131-197-11	3.3	16 V	tantalum
C104	1-121-413-11	100	6.3 V	elect
C105	1-121-409-11	47	16 V	elect
C106(C206)	1-102-973-11	100 p	50 V	ceramic
C301(C401)	1-105-661-12	0.001		
C302(C402)	1-102-963-11	33 p	50 V	ceramic
C303(C403)	1-105-522-12	0.056		
C305(C405)	1-130-006-11	3.3	100 V	film
C306(C406)	1-105-513-12	0.01		
C307(C407)	1-105-661-12	0.001		
C308(C408)	1-102-942-11	5 p	50 V	ceramic
C309(C409)	1-131-195-11	33	10 V	tantalum
C310(C410)	1-105-685-12	0.1		
C311	1-105-841-12	0.047		
C312	1-105-841-12	0.047		
C313(C413)	1-102-978-11	220 p	50 V	ceramic
C315(C415)	1-131-195-11	33	10 V	tantalum
C501(C601)	1-102-947-11	10 p	50 V	ceramic
C502(C602)	1-105-661-12	0.001		
C503(C603)	1-102-965-11	39 p	50 V	ceramic
C504(C604)	1-105-845-12	0.1		
C505(C605)	1-121-927-11	47	10 V	elect
C506(C606)	1-105-661-12	0.001		
C507(C607)	1-102-942-11	5 p	50 V	ceramic

TAE-8450 TAE-8450

Ref. No.	Part No.	Description
C508(C608)	1-105-845-12	0.1
C509(C609)	1-121-927-11	47 10 V elect
C510(C610)	1-105-673-12	0.01
C511(C611)	1-105-665-12	0.0022
C512(C612)	1-121-927-11	47 10 V elect
C513(C613)	1-121-927-11	47 10 V elect
C516(C616)	1-102-947-11	10 p 50 V ceramic
C517	1-105-841-12	0.047
C518	1-105-841-12	0.047
C519(C619)	1-102-963-11	33 p 50 V ceramic
C520(C620)	1-121-912-11	1 50 V elect
C701(C801)	1-121-911-11	0.47 50 V elect
C702(C802)	1-102-972-11	91 p 50 V ceramic
C703(C803)	1-123-054-11	22 16 V elect
C704(C804)	1-102-958-11	20 p 50 V ceramic
C705(C805)	1-105-682-12	0.056
C706(C806)	1-105-682-12	0.056
C707(C807)	1-130-005-11	1 100 V film
C708(C808)	1-131-191-11	47 6.3 V tantalum
C709(C809)	1-131-191-11	47 6.3 V tantalum
C711	1-123-062-11	100 35 V elect
C712	1-123-062-11	100 35 V elect
C901 (C1001)	1-121-913-11	3.3 25 V elect
C902 (C1002)	1-105-661-12	0.001
C904 (C1004)	1-121-419-11	220 6.3 V elect
C905 (C1005)	1-102-942-11	5 p 50 V ceramic
C906 (C1006)	1-121-913-11	3.3 25 V elect
C907 (C1007)	1-102-976-11	180 p 50 V ceramic
C908 (C1008)	1-123-062-11	100 35 V elect
C911 (C1011)	1-121-912-11	1 50 V elect
C912 (C1012)	1-102-978-11	220 p 50 V ceramic

Ref. No.	Part No.	Description
C914 (C1014)	1-121-915-11	4.7 25 V elect
C915 (C1015)	1-102-942-11	5 p 50 V ceramic
C916 (C1016)	1-102-978-11	220 p 50 V ceramic
C917 (C1017)	1-123-062-11	100 35 V elect
C918 (C1018)	1-123-062-11	100 35 V elect
C919 (C1019)	1-102-978-11	220 p 50 V ceramic
C920	1-121-479-11	22 16 V elect
C1101 (C1201)	1-105-845-12	0.1
C1102 (C1202)	1-121-259-11	10 16 V elect
C1103 (C1203)	1-123-055-11	47 16 V elect
C1104 (C1204)	1-105-845-12	0.1
C1105 (C1205)	1-123-055-11	47 16 V elect
C1110 (C1210)	1-105-845-12	0.1
C1111 (C1211)	1-123-055-11	47 16 V elect
C1212	1-105-841-12	0.047
C1213	1-105-841-12	0.047
C1301 (C1401)	1-105-525-12	0.1
C1302 (C1402)	1-121-259-11	10 16 V elect
C1303 (C1403)	1-105-525-12	0.1
C1304 (C1404)	1-123-055-11	47 16 V elect
C1305 (C1405)	1-105-507-12	0.0033
C1306 (C1406)	1-105-507-12	0.0033

Ref. No.	Part No.	Description
C1307 (C1407)	1-105-519-12	0.033
C1308 (C1408)	1-105-519-12	0.033
C1309 (C1409)	1-105-513-12	0.01
C1310 (C1410)	1-105-513-12	0.01
C1311 (C1411)	1-105-507-12	0.0033
C1312 (C1412)	1-105-525-12	0.1
C1313 (C1413)	1-105-525-12	0.1
C1314 (C1414)	1-105-519-12	0.033
C1551 (C1601)	1-105-525-12	0.1
C1502 (C1602)	1-105-521-12	0.047
C1503 (C1603)	1-131-197-11	3.3 16 V tantalum
C1504 (C1604)	1-121-916-11	10 16 V elect
C1505 (C1605)	1-105-501-12	0.001
C1506 (C1606)	1-102-824-11	470 p 50 V ceramic
C1507 (C1607)	1-121-916-11	10 16 V elect
C1901	1-102-355-11	0.01 (2 pieces) 500 V ceramic
C1902	1-102-355-11	0.01 (2 pieces) 500 V ceramic
C1903	1-123-145-11	3,300 (2 pieces) 35 V elect
C1904	1-121-652-11	33 35 V elect
C1905	1-121-391-11	1 50 V elect
C1906	1-121-651-11	10 16 V elect
C1907	1-121-941-11	470 35 V elect
C1908	1-121-652-11	33 35 V elect
C1909	1-121-391-11	1 50 V elect
C1910	1-121-941-11	470 35 V elect

Ref. No.	Part No.	Description
C1911	1-121-396-11	4.7 50 V elect
C1912	1-121-414-11	100 10 elect
C1913	1-102-355-11	0.01 (2 pieces) 500 V ceramic
C1914	1-102-355-11	0.01 (2 pieces) 500 V ceramic
C1915	1-121-944-11	1000 16 V elect
C1916	1-123-063-11	220 35 V elect
C1917	1-105-677-12	0.022
C1918	1-121-805-11	330 10 V elect

RESISTORS

All resistors are Ω . $\frac{1}{4}$ W, $\pm 5\%$, carbon resistors (except particular type) are omitted. Check schematic diagram for the resistance values. k = 1000, M = 100 k

R110	1-202-579-11	1.8 k $\frac{1}{2}$ W composition
R314(R414)	1-211-915-11	5.6 k $\pm 1\%$ (nonflammable)
R317(R417)	1-211-916-11	7.5 k $\pm 1\%$ (nonflammable)
R328(R428)	1-210-506-11	10 k $\pm 1\%$
R329(R429)	1-211-923-11	91 k $\pm 1\%$ (nonflammable)
R513(R613)	1-210-506-11	10 k $\pm 1\%$
R516(R616)	1-211-921-11	47 k $\pm 1\%$ (nonflammable)
R534(R634)	1-210-506-11	10 k $\pm 1\%$
R535(R635)	1-211-923-11	91 k $\pm 1\%$ (nonflammable)
R732(R832)	1-211-913-11	1 k $\pm 1\%$ (nonflammable)
R908 (R1008)	1-202-557-11	220 $\frac{1}{2}$ W composition
R921 (R1021)	1-202-559-11	270 $\frac{1}{2}$ W composition
R922 (R1022)	1-217-359-11	0.47 (2 pieces) 2 W metal
R923 (R1023)	1-202-559-11	270 $\frac{1}{2}$ W composition
R924 (R1024)	1-202-549-11	100 $\frac{1}{2}$ W composition
RT301 (RT401)	1-224-486-11	100, adjustable (equalizer)
RT701 (RT801)	1-224-492-00	100 k, adjustable (peak program meter)

SONY

TAE-8450 SCHEMATIC DIAGRAM

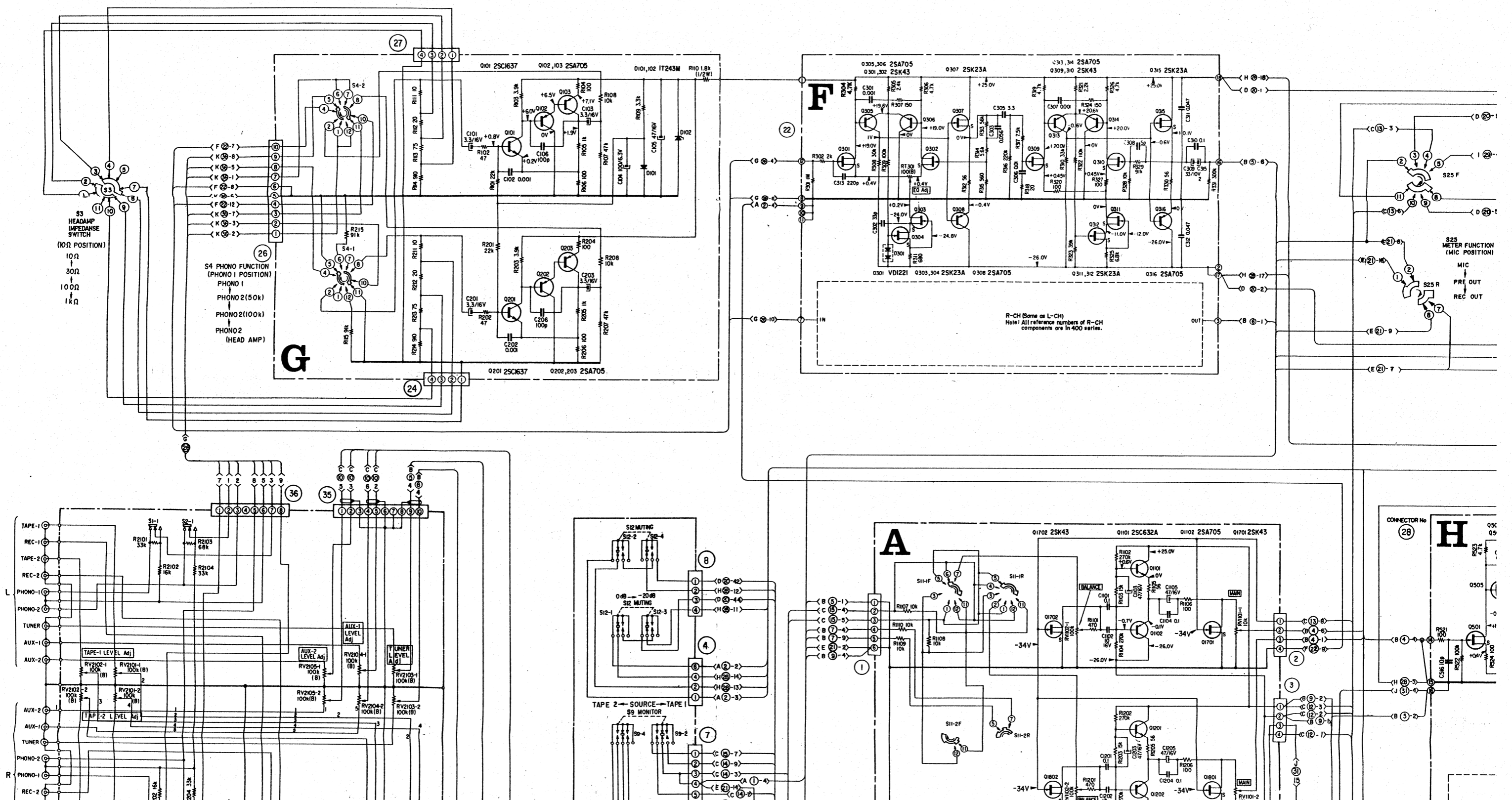

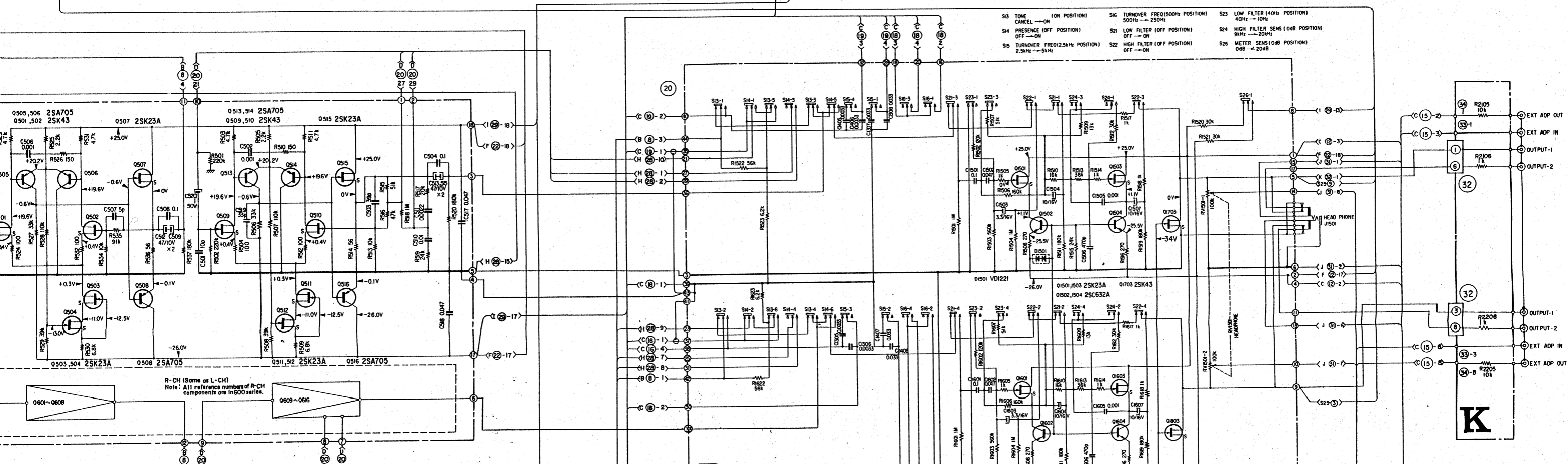
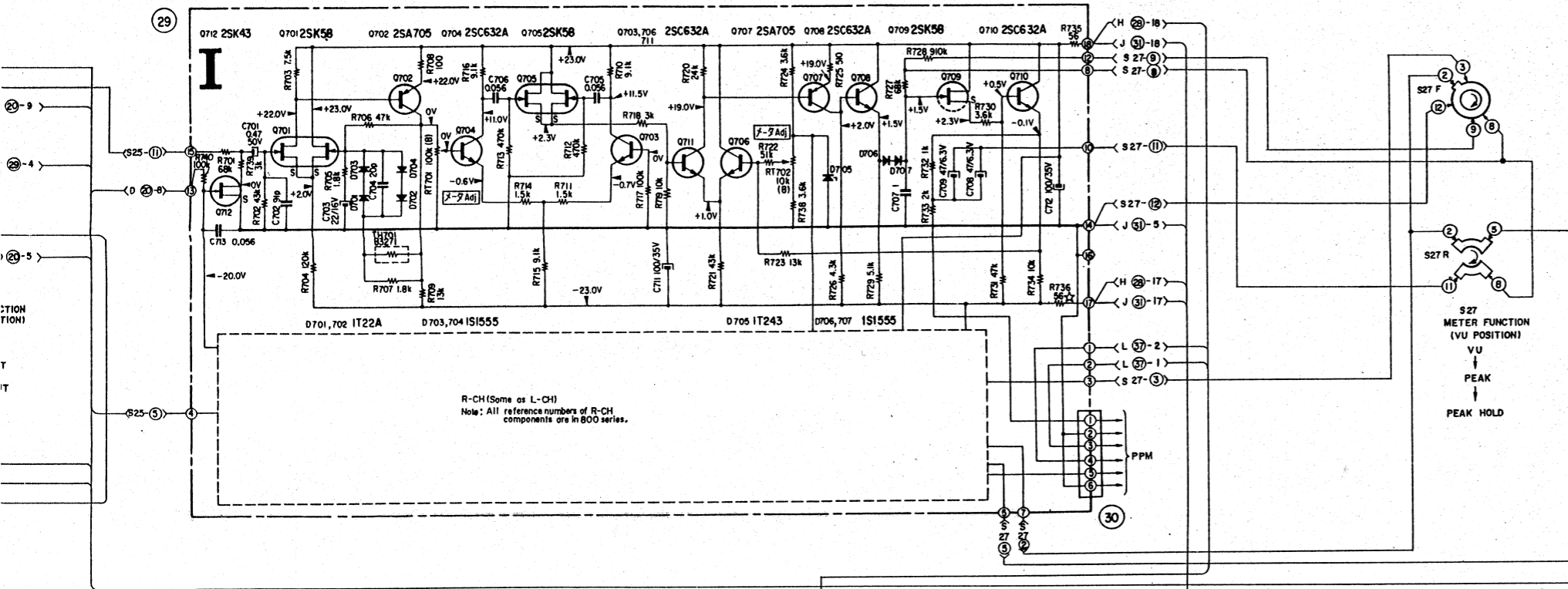

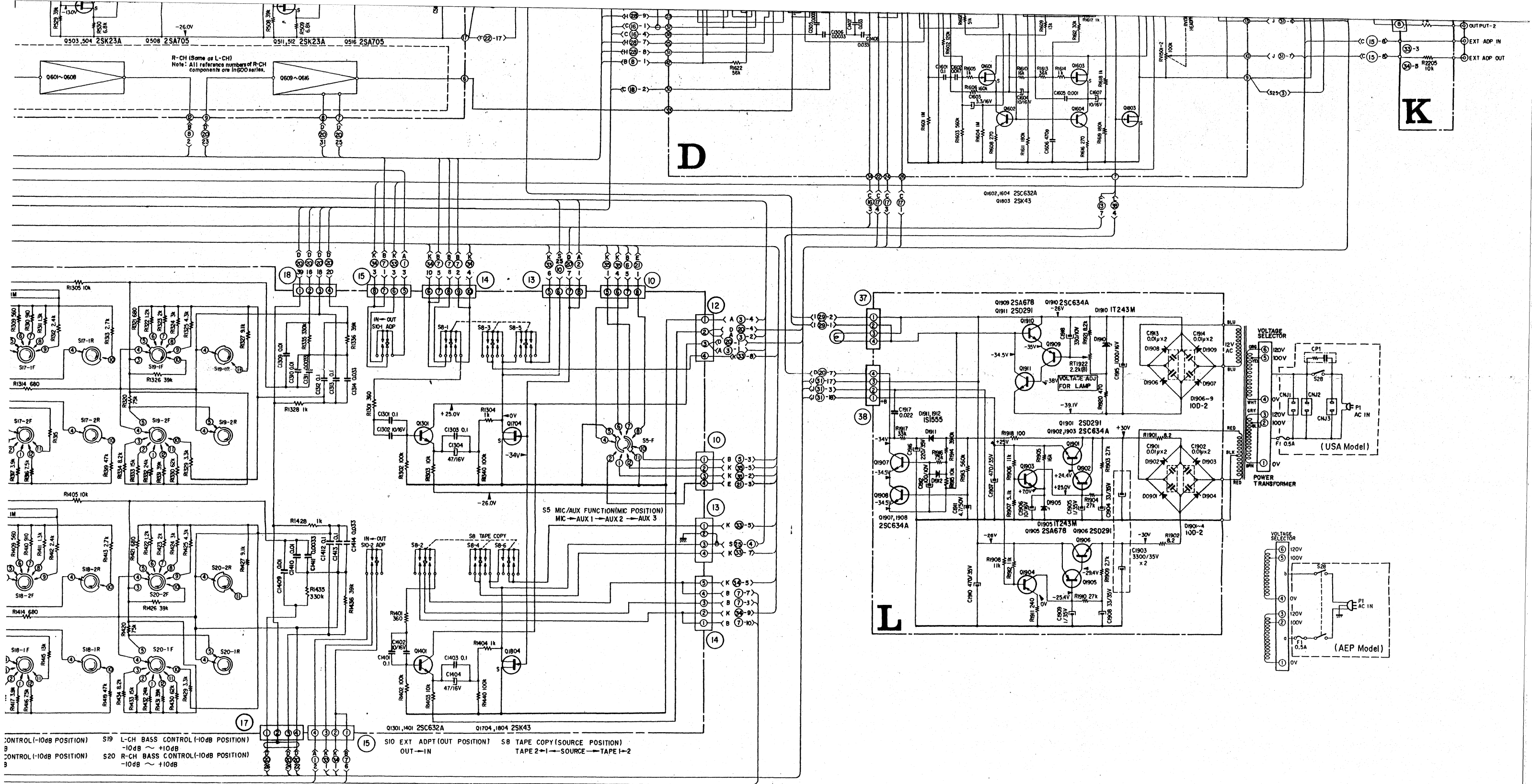

Circuit Boards	Description
A	Volume Control
B	Selector Switch
C	Tone Control
D	Filter
E	MIC/AUX
F	Equalizer

Circuit Boards	Description
G	Phono Head Amp
H	Tone Control Amp
I	Peak Program Meter
J	MIC/Headphone Amp
K	Phono Jack
L	Power Supply

<u>Ref. No.</u>	<u>Part No.</u>	<u>Description</u>
RT702 (RT802)	1-224-493-00	10 k, adjustable
RT1922	1-224-643-XX	2.2 k, adjustable (voltage control)
RV901	1-224-496-11	100 k (B), variable (MIC LEVEL)
RV1101	1-224-495-00	10 k (F), variable (VOLUME)
RV1102	1-224-497-00	100 k (S), variable (BALANCE)
RV1501	1-224-494-00	100 k (B), variable (METER SENS)
RV2101 ~ RV2105	1-224-498-00	100 k (B), variable (LEVEL ADJUST)

SWITCHES

S1, S2	1-516-783-XX	Slide (PHONO SENSITIVITY)
S3	1-516-597-11	Rotary (HEAD AMP IMPEDANCE)
S4	1-516-605-00	Rotary (PHONO FUNCTION)
S5	1-516-596-00	Rotary (MIC/AUX)
S6	1-516-482-00	Lever/Slide (FUNCTION)
S7		– built in RV901 –
S8	1-516-595-00	Lever/Slide (TAPE COPY)
S9	1-516-603-00	Lever/Slide (MONITOR)
S10	1-516-481-00	Lever/Slide (EXT ADPT)
S11	1-516-594-00	Rotary (MODE)
S12	1-516-481-00	Lever/Slide (MUTING)
S13 ~ S16	1-516-601-00	Pushbutton, 4-key (PRESENCE, TURNOVER, FREQ, TONE)
S17, S18	1-516-604-00	Rotary (TREBLE)
S19, S20	1-516-602-00	Rotary (BASS)
S21 ~ S24	1-516-599-00	Pushbutton, 4-key (FILTER)
S25	1-516-598-11	Rotary (METER FUNCTION)
S26		– built in RV1501 –

<u>Ref. No.</u>	<u>Part No.</u>	<u>Description</u>
S27	1-516-600-11	Rotary (PEAK OPERATION)
S28	1-516-585-00	Pushbutton (POWER) (USA Model)
	1-516-628-00	Pushbutton (POWER) (AEP Model)
MISCELLANEOUS		
CNJ1 ~ CNJ3	1-509-403-00	Outlet, ac (USA Model)
CP1	1-101-534-12	Encapsulated Component, (USA Model) 120 Ω + 0.033 μ F
F1	1-532-357-XX	Fuse, 0.5 A
J901, J903	1-507-455-00	Jack, MIC
J902	1-507-453-00	Jack, AUX
J1501	1-507-453-00	Jack, HEADPHONE
L1	1-518-197-XX	Lamp, meter; 8 V/30 mA
M1, M2	1-520-186-11	Meter, PEAK PROGRAM
VS	1-526-520-11	Selector, voltage
	1-507-330-12	Connector, circuit board; 22-P
	1-507-430-XX	Jack, phono; 6-P
	1-507-416-XX	Jack, phono; 4-p
	1-508-648-00	Connector, 4-P (male)
	1-508-649-00	Connector, 6-P
	1-508-650-00	Connector, 10-P
	1-508-651-00	Connector, 10-P
	1-508-652-00	Connector, 8-P
	1-508-692-00	Connector, 8-P
	1-508-693-00	Connector, 10-P
	1-508-694-00	Connector, 8-P
	1-508-695-00	Connector, 6-P
	1-509-546-00	Connector, AC IN, 3-P (AEP Model)
	1-509-668-00	Connector, circuit board; 18-P
	1-518-239-00	Lamp (included in PEAK PROGRAM meter)
	1-533-089-XX	Holder, fuse; 2-P
	1-534-992-XX	Cord, power (USA Model)
	1-536-354-00	Pin, terminal
	1-536-401-XX	Terminal Strip, 1L1

ACCESSORIES

<u>Part No.</u>	<u>Description</u>	<u>Part No.</u>	<u>Description</u>
1-506-113-00	Plug, shorting	3-780-431-21	Manual, instruction
1-534-049-51	Cord, connection; RK-74	3-793-766-21	Sheet, supplemental (AEP Model)
1-534-514-13	Cord, connection; RK-81	3-793-767-00	Sheet, checking
1-534-514-22	Cord, connection; RK-81	3-793-785-00	Cover, instruction manual
1-534-754-00	Cord, power (AEP Model)		