

The Sony TAE-8450 preamplifier is intended for the serious audiophile, and combines avant-garde engineering with traditional Sony quality and craftsmanship. More closely than ever before, it approaches the ultimate goal desired by the perceptive listener—a device virtually free from coloration, and save for amplitude, producing an exact image of the input signal.

This realism can be attributed to an intensive effort to reduce all factors contributing to distortion. Significant advances in the elimination of transient and phase distortion are made possible in the TAE-8450 by the use of an exceptionally wide and flat pass-band with an accurate phase transmission characteristic. Harmonic and intermodulation figures reach a new low thanks to the most advanced solid-state circuitry and components, while a minimal residual noise level and wide dynamic signal handling range make this preamplifier especially suited for the reproduction of the best available tape and disc recordings.

From an operational standpoint, the TAE-8450 offers a user-oriented panel layout, with numerous innovative features in addition to those normally expected, such as studio mixer type Peak Program Meters for transient peak monitoring, and a precision attenuator type volume control. Convenience features include multiple inputs with semi-fixed input level controls, phono impedance selectors, direct tape dubbing facilities, sharply delineated tone controls for precise acoustic compensation, supersonic and subsonic filters, and quick-access input selectors.

To derive the utmost in pleasure and utility from your preamplifier, please read this manual completely to become familiar with all its features and capabilities. Keep this manual handy for future reference.

**Stereo Power Amplifier TAN-8250**



**Stereo Preamplifier TAE-8450**



# TABLE OF CONTENTS

# UNPACKING

Pages	
3	WARNING
3	UNPACKING
3	PRECAUTIONS
4	LOCATION OF PARTS AND CONTROLS
6	TAE-8450 REAR PANEL FACILITIES
6	CONNECTION NOTES
6	CONNECTION DIAGRAM
8	RECORD PLAYERS
8	TUNER
8	TAPE RECORDERS
8	OTHER INPUT SOURCES
9	EXTERNAL ADAPTOR CONNECTORS
9	POWER AMPLIFIERS
9	POWER CONNECTIONS
9	GROUND TERMINAL
9	INPUT LEVEL ADJUSTMENTS
10	TAE-8450 FRONT PANEL FACILITIES
10	GENERAL CONTROL SECTION
12	INPUT SELECTION SECTION
13	TONE CONTROL SECTION
14	METER FUNCTION SECTION
15	OPERATING INSTRUCTIONS
15	INITIAL OPERATION
16	PROGRAM SELECTION
16	SOUND ADJUSTMENTS
16	NOTES ON MIC USE
17	USING THE METERS FOR AUDIO MEASUREMENTS
17	CARTRIDGE CHECKS
18	TAPE RECORDER CHECKS
18	ACOUSTIC CHARACTERISTICS CHECK
19	CARE OF YOUR EQUIPMENT
19	TROUBLE CHECKS
19	CLEANING
19	REPACKING FOR SHIPMENT
20	TECHNICAL DATA
20	BASIC DESIGN OF THE TAE-8450
20	THE PEAK PROGRAM METER
22	THE PRECISION STEP ATTENUATOR
23	BLOCK DIAGRAM
24	SPECIFICATIONS
26	OWNER'S TEST DATA

Do not throw away the TAE-8450 carton and the associated material; they will come in handy if you ever have to transport or ship your set. Inspect your TAE-8450 immediately after unpacking. If any sign of damage is found, consult your local Sony dealer.

## PRECAUTIONS

Correct installation and proper operation contribute both to your safety and to the continued trouble free operation of your new TAE-8450. Make sure that your installation and operating procedures comply with these requirements.

- Operate the TAE-8450 only on 120 V ac 60 Hz.
- Should any liquid or foreign objects fall into the cabinet, unplug the set and have it checked before operating.
- Good air circulation is essential to prevent internal heat build-up in the TAE-8450. Place the set in a location with adequate air circulation. Don't place the set on soft surfaces such as a rug or blanket that would block the ventilation holes on the bottom.
- Don't place anything on top of the cabinet. The top ventilation holes must be unobstructed for the proper operation of the TAE-8450 and to prolong the life of its components.
- Don't install the TAE-8450 in a location near heat sources such as radiators or air ducts, or in a place subject to direct sunlight, excessive dust, mechanical vibration or shock.
- Unplug the set from the wall outlet if it is not to be used for an extended period of time.
- To disconnect the cord, pull it out by the plug. Never pull the cord itself.
- While making connections, be sure to unplug the set and to turn the power switch off.
- When the set is not used, turn the power off.

## WARNING

To avoid electrical shock, do not open the cabinet.  
Refer servicing to qualified personnel only.

To prevent fire or shock hazard, do not expose the set to rain or moisture.

# LOCATION OF PARTS AND CONTROLS

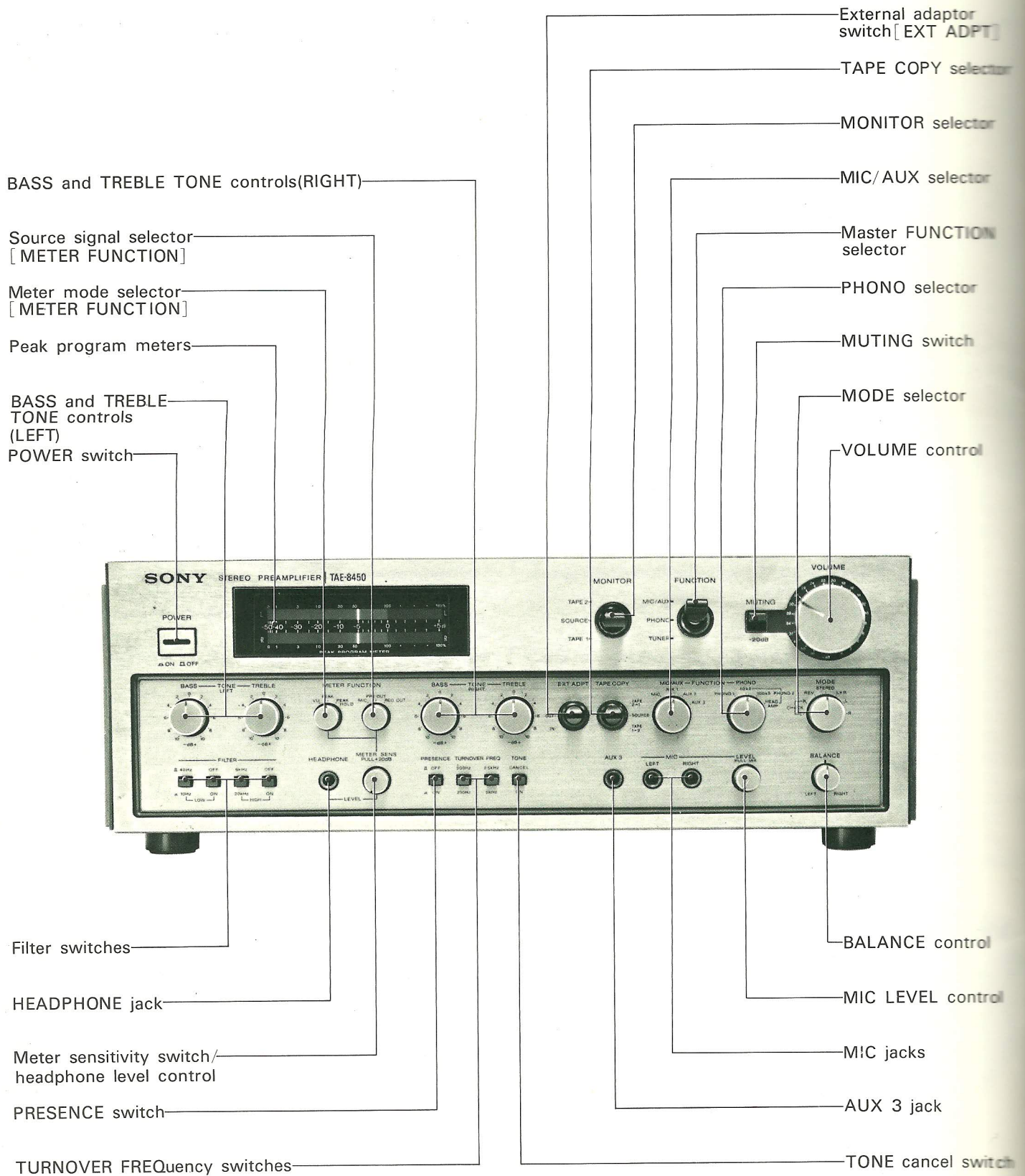

HEAD AMP IMPEDANCE selector  
 By setting the front panel  
 PHONO selector to HEAD AMP,  
 the PHONO 2 inputs  
 are connected to the head amp circuit.

PHONO SENSITIVITY switches

LEVEL ADJUST controls

AC OUTLETS

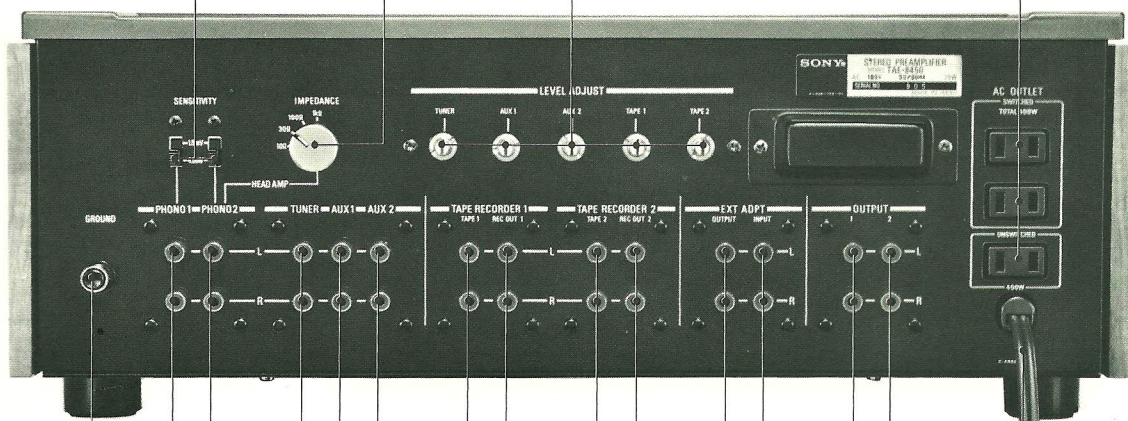

GROUND terminal

PHONO (1 and 2) inputs

TUNER inputs

AUX (1 and 2) inputs

Ac power cord

Preamp OUTPUT (1 and 2) jacks

External adaptor jacks [EXT ADPT]

TAPE RECORDER (1 and 2) jacks

# TAE-8450 REAR PANEL FACILITIES

## CONNECTION NOTES

To assure correct matching at the input and output terminals of your audio system, refer to the table of "SPECIFICATIONS" on page 24, and to the specifications given in the instruction manuals provided with the components you wish to connect to the TAE-8450. Generally the output level of a signal source (phono cartridge, tape recorder, etc.) should be equal to or slightly greater than the sensitivity of the corresponding input. Also the output impedance of a signal source should be considerably lower than the impedance of the corresponding input. For example, a tape recorder having an output level and impedance of 250 mV and 10 kΩ respectively can be connected to the TAE-8450 TAPE inputs which are rated at 150 mV and 50 kΩ.

For all program source input and output connections use a low-capacitance type shielded cable. Keep the cables as short as practicable, avoiding horizontal runs. Excessively-long runs (over 6 feet) tend to reduce the high frequency response, while horizontal runs are susceptible to power line hum pickup.

When using the supplied cables, be sure to connect the red plug to the Right [R] jack and the remaining one to the Left [L]. The cable connectors should be fully inserted into the jacks. A loose connection may cause hum and noise.

If reconnections are made, be sure to lower all source level controls and turn off the TAE-8450 to avoid possible speaker damage.

Insert the shorting plugs (supplied) for muting the PHONO 1 and PHONO 2 input terminals when these inputs are not in use.

When using the supplied connecting cord (with binaural plug), be sure to connect the white phono plug to the left channel, and the red phono plug to the right channel.

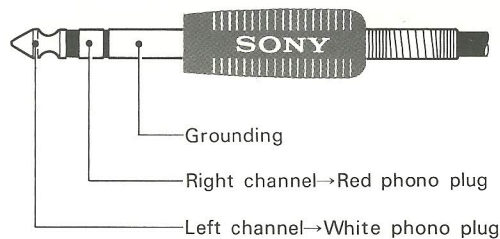

## CONNECTION DIAGRAM

### EXT ADPT

INPUT	150 mV	50 kΩ
OUTPUT		10 kΩ

### TAPE RECORDER 1 · 2

TAPE 1 · 2	150 mV	50 kΩ
REC OUT 1 · 2		1 kΩ

### PHONO 1 · 2

PHONO 1	1.5 mV	50 kΩ
PHONO 2	4.5 mV	50 kΩ/100 kΩ
HEAD AMP	0.16 mV	10 Ω/30 Ω/100 Ω/1 kΩ

### TUNER, AUX 1 · 2 · 3

TUNER	150 mV	50 kΩ
AUX 1 · 2 · 3		

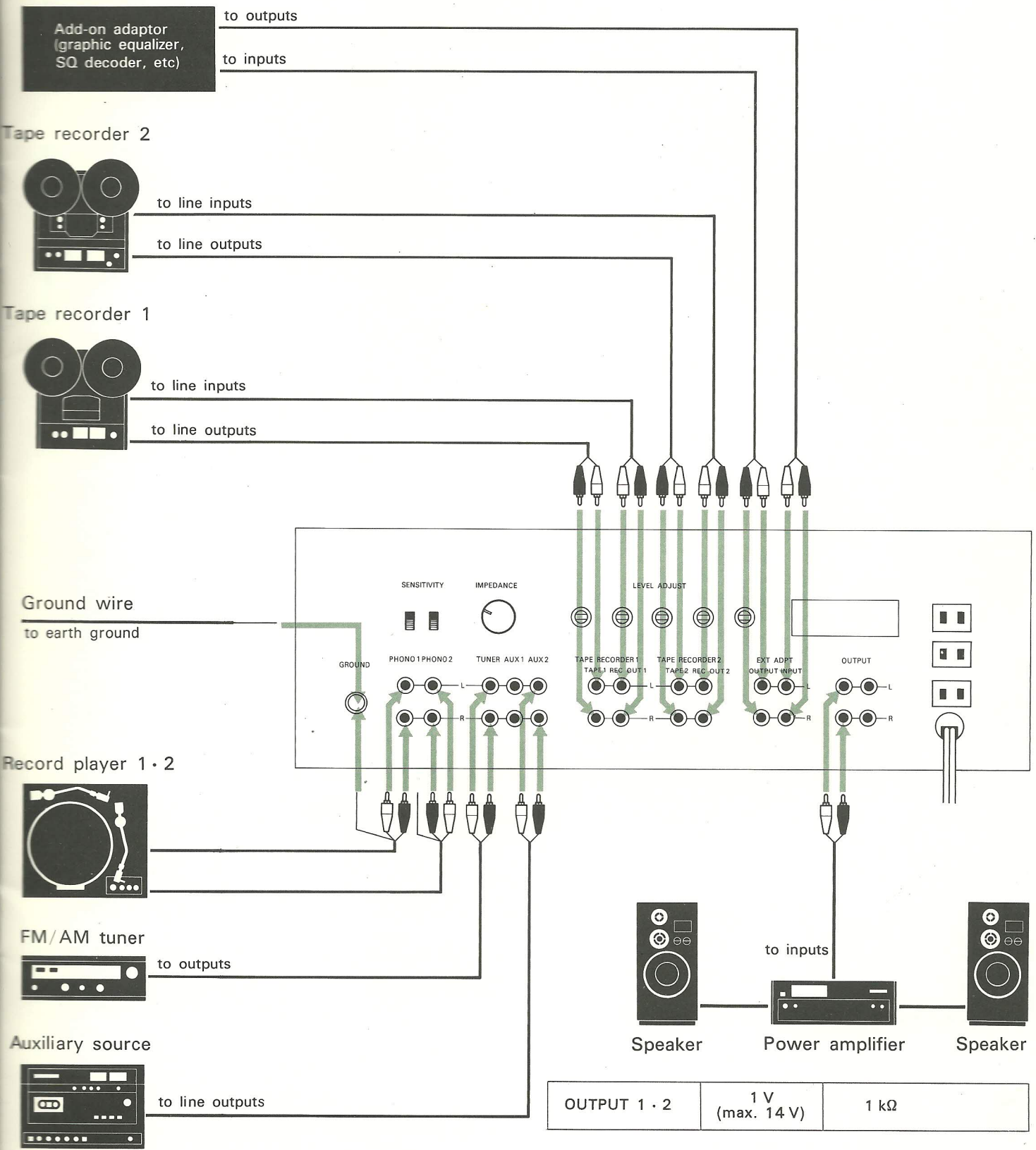

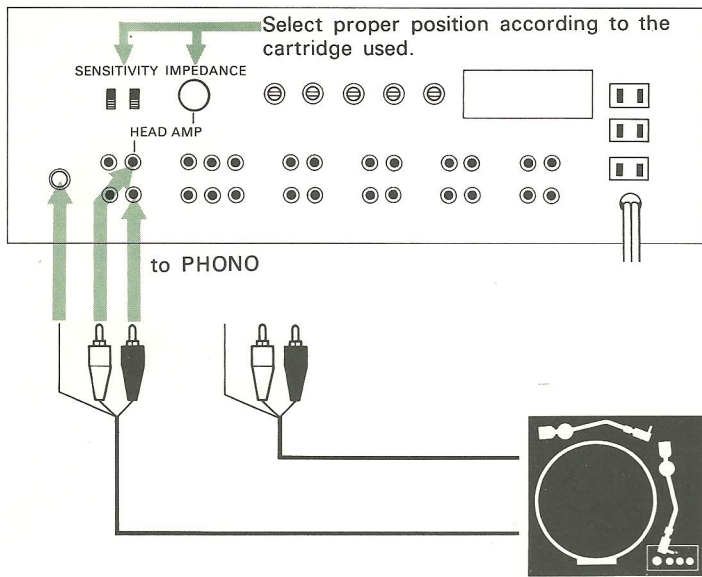

Insert the shorting plugs into the unused PHONO inputs.

## RECORD PLAYERS

The TAE-8450 can accept two phonographs equipped with any type of magnetic cartridge (moving magnet, moving coil and induced magnet type) on the market. Select the most suitable amplifier inputs for your cartridge, depending on the output and impedance specified in the manual supplied with the cartridge. If they are odd values, a higher value setting is suggested.

**PHONO 1:** Set the associated phono SENSITIVITY switch to either 1.5 mV or 4.5 mV to match the output level of the cartridge connected. These inputs have an input impedance of 50 kΩ. Use the PHONO 2 jacks to operate with cartridges requiring other input impedances.

**PHONO 2 (high level input use):** With the front panel PHONO selector set to a PHONO 2 position, these jacks operate similarly to the PHONO 1 jacks, providing an input sensitivity selection of 1.5 mV or 4.5 mV. The input impedance can be set to 50 kΩ or 100 kΩ by this front panel PHONO selector.

**HEAD AMP use at PHONO 2:** With the PHONO selector set to HEAD AMP, the PHONO 2 jacks operate as phono HEAD AMP inputs having 0.16 mV sensitivity and will accept a very low-output moving coil cartridge. An input impedance of 10 Ω, 30 Ω, 100 Ω or 1 kΩ can be selected by the rear panel HEAD AMP IMPEDANCE selector.

### CAUTION

The PHONO selector should not be reset from PHONO 1/ PHONO 2 to HEAD AMP while the system is powered. Similarly do not move the HEAD AMP IMPEDANCE selector or the SENSITIVITY switches while operating. If it is necessary to reset these selectors in an operating system, be sure to turn the volume all the way down to prevent accidental speaker damage.

## TUNER

Connect the line outputs of your tuner to the TUNER inputs. The AUX (1, 2 or 3) inputs also accept tuner outputs. The TUNER and AUX (1 and 2) input sensitivities are semifixed and adjustable. Refer to "INPUT LEVEL ADJUSTMENTS" on next page.

## TAPE RECORDERS

Two pairs of TAPE RECORDER connectors (1 and 2) are provided. They will serve for direct tape duplication or for making two recordings simultaneously. The signals applied to the REC OUT jacks are determined by the front panel TAPE COPY selector setting (refer to "TAPE COPY selector" on page 12). For the TAPE input sensitivity adjustment refer to next page.

## OTHER INPUT SOURCES

The AUX 1, AUX 2 and AUX 3 jacks have been provided for connecting various input sources such as a cassette player, additional tuner, record player equipped with a ceramic or crystal cartridge, etc. The AUX 3 jack on the front panel is convenient for connecting an input source for temporary use. For this connection, use the binaural-plug cord supplied.

The microphone and headphone connections are described on page 11.

### Connection diagram of a quadraphonic sound setup

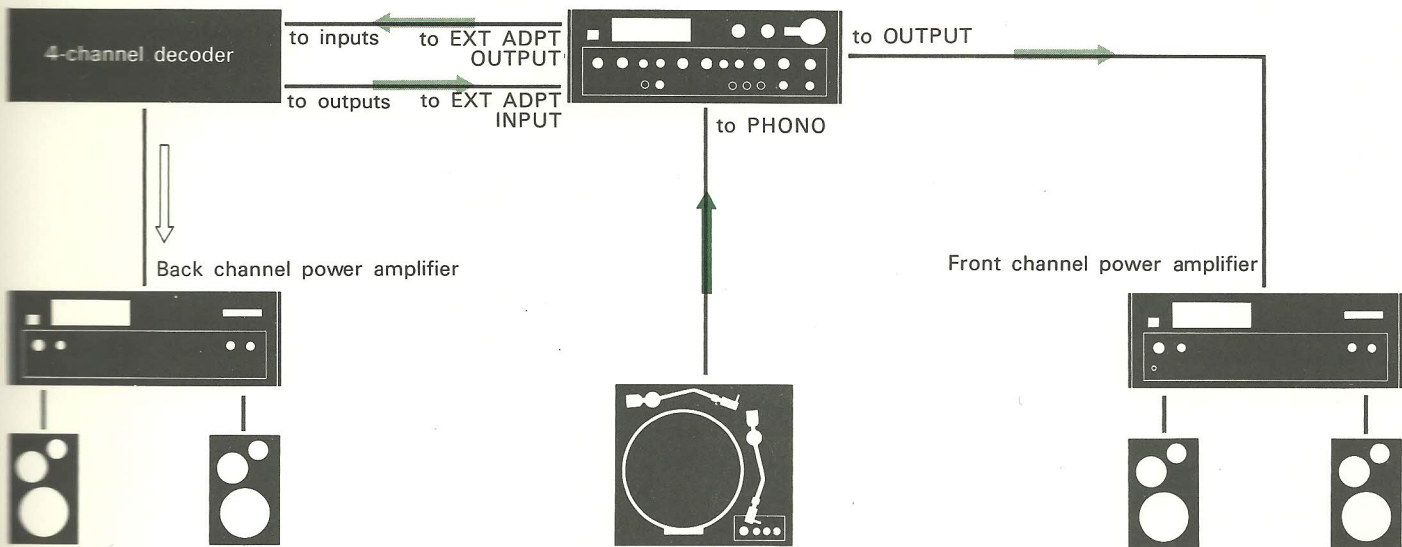

## EXTERNAL ADAPTOR CONNECTORS

These jacks accept an add-on adaptor such as a graphic equalizer, speaker equalizer, SQ adaptor (for a quadraphonic sound setup), or a tape recorder; connect the EXT ADPT. OUTPUT jacks to the inputs of the add-on equipment and the EXT ADPT INPUT jacks to the outputs of the equipment. Note: When using these jacks, be sure to set the front panel EXT ADPT switch to IN. When not in use, set it to OUT. If these precautions are not observed, the signal path is not completed and no sound will be heard.

## POWER AMPLIFIERS

Connect the TAE-8450 OUTPUT jacks (1 or 2) to the input jacks of the power amplifier. The rated output level is 1.0 V. When using the HEADPHONE jack, the OUTPUT 2 jacks are disconnected, but the OUTPUT 1 jacks remain live. When the TAE-8450 feeds program material to two sound systems, use OUTPUT 1 for the remote sound system, and OUTPUT 2 for the local system. In this way you can use the HEADPHONE jack without affecting the remote sound system.

## POWER CONNECTIONS

Before making any form of power connection, make sure the TAE-8450 POWER switch is OFF. Then you can plug the TAE-8450 line cord into the electrical outlet.

Receptacles on the rear of the chassis provide a convenient source of ac power for other system components. The SWITCHED outlets are controlled by the front panel POWER switch, and the total power consumption of all equipments plugged into these outlets must not exceed 400 watts. The UNSWITCHED outlet is not controlled by the POWER switch, and this outlet also supplies ac power up to 400 watts (maximum).

## GROUND TERMINAL

To prevent hum be sure to connect the ground wire of the player to the GROUND terminal. If hum still exists it may be helpful to connect the GROUND terminal to the plate screw of an ac outlet or directly to earth via a ground rod.

## INPUT LEVEL ADJUSTMENTS

To eliminate the need to reset the volume control when switching between program sources, the TAE-8450 has semi-fixed LEVEL ADJUST controls for TUNER, AUX 1, AUX 2, TAPE 1 and TAPE 2 inputs. Balance input levels as follows:

1. Set the MODE selector to L+R.
2. Listen to each program source and find the one with the lowest volume. Use this as your standard source.
3. Turn all LEVEL ADJUST controls fully counterclockwise except for the standard source input (Step 2). Turn the LEVEL ADJUST control of the standard source fully clockwise.
4. Keep the input selectors (MONITOR and FUNCTIONS) set to the source chosen in Step 2, and establish a comfortable listening level by turning the VOLUME control. Use this level as a standard for balancing the input levels.
5. Compare the volume level of other sources by switching the input selectors (MONITOR and FUNCTIONS) back-and-forth between the standard source and the other sources, and adjust their LEVEL ADJUST controls until the same sound level is obtained from each source. The meters will be helpful in these adjustments.

Note: Keep the VOLUME control at the original setting (Step 4) while these adjustments are being made. Use similar program sources for these adjustments.

# TAE-8450 FRONT PANEL FACILITIES

This section describes the operation and function of each facility on the front panel of the TAE-8450. For clarity, these are grouped into four functionally related sections, as follows.

## GENERAL CONTROL SECTION (on pages 10 and 11)

- POWER switch
- VOLUME control
- MUTING switch
- MODE selector
- BALANCE control
- MIC jacks (L and R)
- MIC LEVEL control
- HEADPHONE jack
- HEADPHONE LEVEL control (dual function)
- AUX 3 jack

## INPUT SELECTION SECTION (on page 12)

- MONITOR selector
- Master FUNCTION selector
- PHONO selector
- MIC/AUX selector
- EXT ADPT switch
- TAPE COPY selector

## TONE CONTROL SECTION (on page 13)

- BASS TONE controls(L and R)
- TREBLE TONE controls(L and R)
- TURNOVER FREQUENCY switches
- TONE cancel switch
- PRESENCE switch
- LOW FILTER switch
- HIGH FILTER switch

## METER FUNCTION SECTION (on page 14)

- The Peak Program Meters
- METER FUNCTION (left, meter mode selector)
- METER FUNCTION (right, source signal selector)
- METER SENS PULL +20 dB switch (dual function)

## GENERAL CONTROL SECTION

### POWER switch

Turns the operating power on or off. The switch lights with a soft green glow.

### VOLUME control

This precisely matched attenuator control regulates the overall sound level. Note that the "0" indication (the fully clockwise position) means that the volume control provides zero attenuation (full gain amplification). Counterclockwise rotation from "0" to "-34" position lowers the volume in "2 dB" steps, that change in level being considered to be the minimum detectable by the human ear. Adjust the volume while observing the Peak Program Meter. If the preamp output level exceeds 0 dB (1.0 V), which is the reference input sensitivity of modern power amplifiers, the optical pointer of the meter turns to red.

Note: To prevent inadvertent speaker damage, lower the volume each time you turn on or shut down the system.

### MUTING switch

When depressed the sound level is decreased 20 dB. This switch is useful when you lower the phono cartridge onto the disc or when you wish to use the telephone. Also, this switch permits obtaining the direct output of the phono equalizer if so required. To do so, depress the switch (and the 20 dB flat amplifier is disconnected), set the TONE cancel switch to CANCEL, both HIGH and LOW FILTER switches to OFF, and the PRESENCE switch to OFF.

**GENERAL CONTROL SECTION**

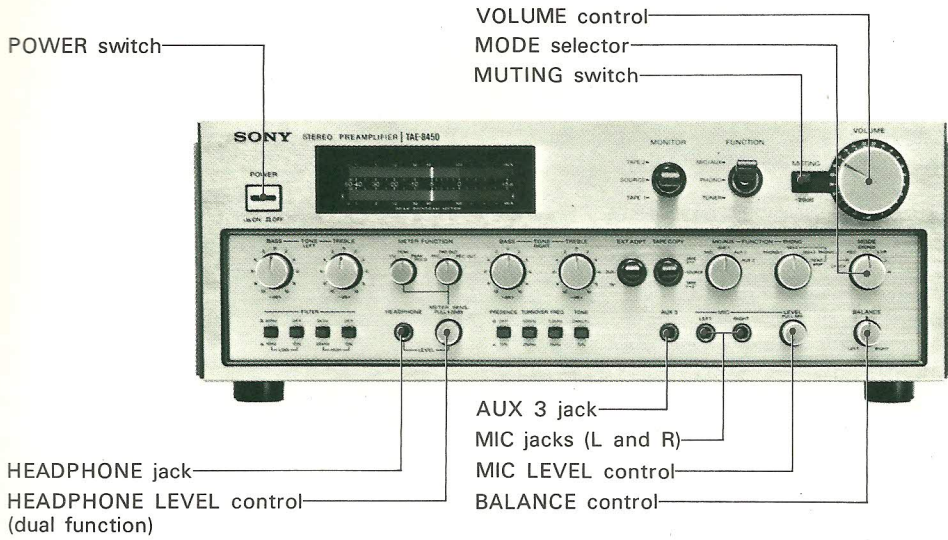

**MODE selector**

Determines the mode of the program reproduced at the OUTPUT 1, 2 and HEADPHONE jacks.

MODE selector setting	Input → Output	Use
CHECK L	L (left) → L R (right) → R	To check left channel output
CHECK R	L → L R → R	To check right channel output
Reverse (REV)	L → R R → L	To reverse right and left stereo sound
STEREO	L → L R → R	Normal stereo sound
L+R	L → L R → R	Mono sound
Left	L → L R → R	To amplify a monaural input source
Right	L → L R → R	

This selector has no effect upon the REC OUT (1 and 2) and EXT ADPT OUTPUT jacks.

**BALANCE control**

Regulates the level of either the left or right channel without changing the total sound volume.

**MIC jacks (L and R) and LEVEL control**

These jacks accept either low or high impedance microphones. To control the sensitivity of the mic amp, pull and turn the associated knob. To use only mic, set the MIC/AUX selector to MIC, master FUNCTION selector to MIC/AUX, and MONITOR selector to SOURCE. With other settings, the mic signal is mixed with the line signal path. On mixing play, the line program level is reduced.

When the mic is not used, keep the LEVEL knob depressed so that the mic signal is internally cut off.

Note :

- If you set the right side METER FUNCTION knob to MIC, during mic play, the meters directly read out the mic amp output, but the mic signals are not supplied to the OUTPUT jacks.

- The input signal at the LEFT MIC jack connects to both left and right channels when only the LEFT jack is plugged in.

**HEADPHONE jack and LEVEL control (dual function)**

This jack accepts any low or high impedance stereo headphones. The associated knob is a dual-function knob which regulates the headphone level when turned and decreases the sensitivity of the Peak Program Meter by 20 dB when pulled out. For meter sensitivity switch use, refer to page 14.

Note : When this jack is used the OUTPUT 2 jacks are cut off.

**AUX 3 jack**

Accepts a binaural phone plug to permit a front panel connection of any suitable auxiliary signal source. It is activated by the MIC/AUX selector.

### INPUT SELECTION SECTION

MONITOR selector  
 TAPE COPY selector  
 EXT ADPT switch

MIC/AUX selector  
 Master FUNCTION selector  
 PHONO selector

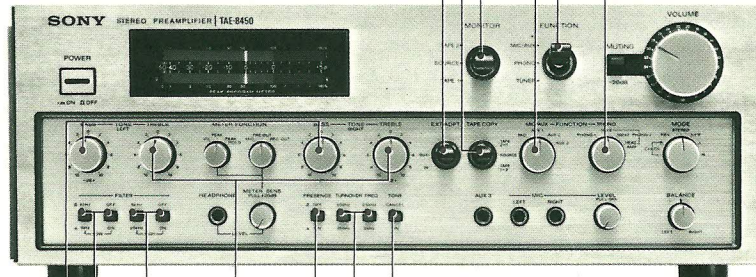

### TONE CONTROL SECTION

BASS TONE controls  
 (L and R)  
 LOW FILTER switches  
 HIGH FILTER switches

TONE cancel switch  
 TURNOVER FREQUENCY switches  
 PRESENCE switch  
 TREBLE TONE controls(L and R)

## INPUT SELECTION SECTION

### MONITOR selector

TAPE 1 . . . . .Tape connected to the TAPE RECORDER 1 jacks  
 TAPE 2 . . . . .Tape connected to the TAPE RECORDER 2 jacks  
 SOURCE . . . . .For all other program sources, set the selector to this position, and set the master FUNCTION selector to the proper mode.

### Master FUNCTION selector

MIC/AUX . . . . .For mic or auxiliary program, set the selector to this position, and set the MIC/AUX selector to the desired input source.

PHONO . . . . .For disc programs, set the selector to this position and set the PHONO selector to the proper mode.

TUNER . . . . .For the off-the-air program connected to TUNER inputs.

### PHONO selector

PHONO 1 . . . . .Disc program connected to the PHONO 1 inputs.  
 PHONO 2 -50 kΩ, -100 kΩ . . . . .Disc program connected to the PHONO 2 inputs; select the suitable impedance (50 kΩ or 100 kΩ) according to the cartridge instructions.

PHONO 2 HEAD AMP . . . . .To use a low-level moving-coil cartridge connected to PHONO 2 inputs.

### MIC/AUX selector

MIC . . . . .To amplify **only** mic signal

AUX 1, 2, 3 . . . . .For the program connected to the corresponding numbered AUX inputs.

### External Adaptor Switch [EXT ADPT]

Normally this switch is OUT. When connecting an add-on adaptor such as a graphic equalizer, SQ adaptor, etc. to the EXT ADPT jacks, set the switch to IN.

Note: No sound will not be heard if you set this switch to IN without connecting some device to the EXT ADPT jacks.

### TAPE COPY selector

Selects the signal applied to the REC OUT 1 and REC OUT 2 jacks. Normally keep this selector at the center position (SOURCE); a PHONO, TUNER, AUX or MIC program selected by the associated function selectors is applied to both REC OUTputs. For direct tape dubbing, use the TAPE 1 → 2 or 2 → 1 position; with TAPE 1 → 2 setting, TAPE 1 signal appears at REC OUT 2 jacks, and with TAPE 2 → 1 setting, TAPE 2 signal appears at REC OUT 1 jacks. Tape dubbing is made independently of the sound reproduction which is selected by the function selectors.

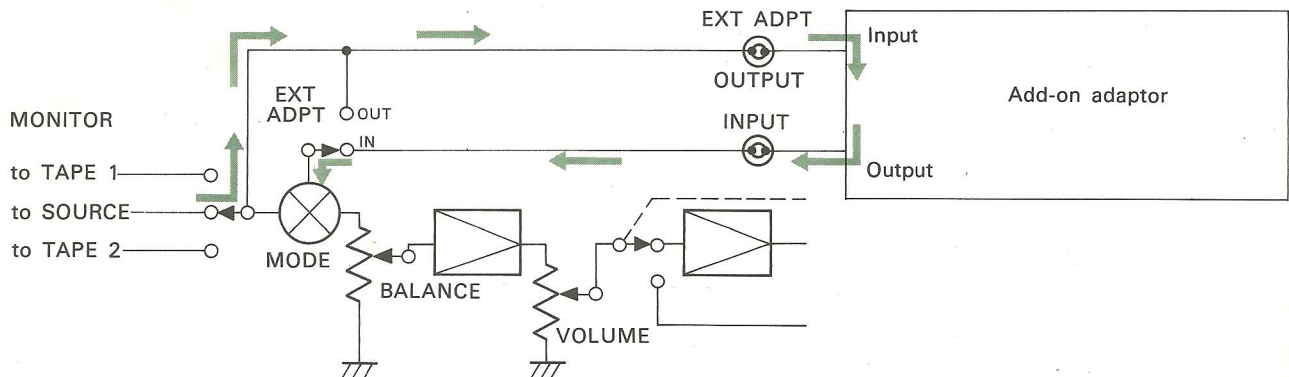

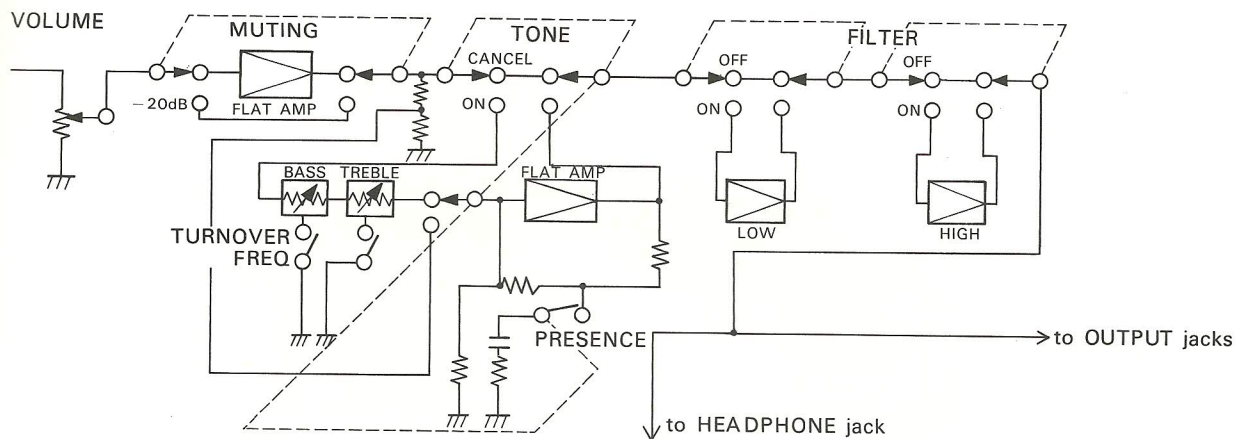

## TONE CONTROL SECTION

### BASS TONE controls(L and R)

These alter the bass response  $\pm 10$  dB in 2 dB steps. Turn clockwise to increase response, counterclockwise to decrease response. The center position provides a flat response.

### TREBLE TONE controls (L and R)

These alter the treble response  $\pm 10$  dB in 2 dB steps. Turn clockwise to increase response, counterclockwise to decrease response. The center position provides a flat response.

### TURNOVER FREQUENCY switches

These switches select the frequency point at which the bass (or treble) tone control begins to take effect, so that you can change the bass (or treble) extremes with less effect on the mid-range; TREBLE selects 2.5 kHz (released) or 5 kHz (depressed), and BASS selects 500 Hz (released) or 250 Hz (depressed)

### TONE cancel switch

**CANCEL** (released)... Bass and treble tone control circuits are disconnected from the signal path and an absolutely flat frequency response\* is obtained regardless of the BASS and TREBLE control settings.

**ON** (depressed)... The BASS and TREBLE TONE controls work normally.

\* The response is still subject to the action of the HIGH and LOW filters and the PRESENCE switch, and these must of course be in their OFF positions for a flat response.

### PRESENCE switch

When reproducing a vocal program (especially female vocal), depress this switch to ON. A mid-range equalization network (3.5 dB boost at 1 kHz) works to emphasize the impression of the vocalist.

Note: This switch works independently of the TONE cancel switch.

### LOW and HIGH FILTER switches

ON/OFF switches and cut-off frequency selectors are provided. With the ON/OFF switch released (OFF), the associated FILTER circuit is disconnected from the signal path and has no effect on the frequency response. With the switch depressed (ON), the associated filter operates to attenuate the response above the selected HIGH points of 9 kHz or 20 kHz, or below the selected LOW points of 10 Hz or 40 Hz, at a 12 dB/octave rate, so that unwanted noise components are substantially reduced. Select the desired cutoff frequency with the associated switch:

**LOW 10 Hz (depressed)**... If subsonic noise components are present from the turntable, tape recorder motor, etc., the audible range frequencies may be modulated and cause irritating intermodulation distortion. This subsonic filter is ideal for eliminating such possible causes of IM distortion without affecting the audible range frequencies, and also prevents speaker damage caused by inadvertent dc content signal flow.

**LOW 40 Hz (released)**... Low frequency noise below 40 Hz, such as the rumble created by turntables, record changers, or warped records is reduced.

**HIGH 9 kHz (released)**... High frequency noise above 9 kHz, such as the surface noise of records or tapes when reproducing old or poor quality recordings, or high frequency distortion in records or tapes, is reduced.

**HIGH 20 kHz (depressed)**... If the source program contains extreme high frequency noise, fm stereo pilot signal interference, bias leakage of recorders, etc., this filter preserves the tweeter unit (especially a super-tweeter) from accidental damage. The filter reduces supersonic response by 12 dB/octave while having no effect on the audible range.

## METER FUNCTION SECTION

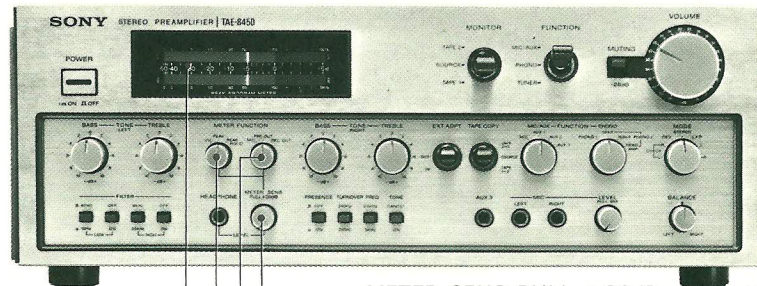

—METER SENS PULL + 20dB switch (dual function)  
 —METER FUNCTION (right, source signal selector)  
 —METER FUNCTION (left, meter mode selector)  
 —The Peak Program Meters

## METER FUNCTION SECTION

### The Peak Program Meters

You can monitor the MIC, PRE OUT, and REC OUT signals in the desired modes of peak program, peak hold, and VU readings, over the  $-50$  dB to  $+5$  dB range that is critical for truly professional monitoring. The pointer light turns to red beyond 0 dB (1.0 V) reading to alert you that the preamp output level exceeds the reference sensitivity of the power amplifier. With Peak Program Monitoring you can operate the connected power amplifiers or tape recorders within their maximum input capability without causing any clipping. This precision meter will also serve for measuring the performance of cartridges, tape heads, and room acoustics with laboratory accuracy. The meter sensitivity can be reduced 20 dB by the associated dual-function knob.

### METER FUNCTION (left, meter mode selector)

**VU**... Provides an approximate VU operation which indicates the average level of complex musical waveforms. This position is especially suited for monitoring relative levels for channel balancing or mixing-level adjustment.

**PEAK**... Operates as a Peak Program Meter indicating the instantaneous peak of the input signal which, unless monitored, could overload the input sensitivities of the connected power amplifiers or tape recorders. The Peak Program Meter response is designed to follow a fast signal rise time of 1 msec and to have a slow decay time of 1.0 sec for accurate readings without excessive pointer fluctuations.

**PEAK HOLD**... Operates as a Peak Program Meter but in this position the meter holds the indication of the highest peak for a much longer time.

**Note:** Do not turn on the power during PEAK HOLD mode. If you do, the meter may hold a false signal level caused by switching transients generated at the meter drive amplifier.

### METER FUNCTION (right, source signal selector)

**MIC**... The mic amp output signal level is directly indicated. Use this position for a room acoustic check. Note that this

position breaks the mic signal path in the amplification chain, so that the mic signals are not applied to all preamp outputs. Refer to "ACOUSTIC CHARACTERISTICS CHECK" on page 18.

**PRE OUT**... The preamp OUTPUT signal level is indicated. Since the reference input sensitivity of modern power amplifiers is generally rated at 1.0 V, adjust the preamplifier volume so that the pointer does not exceed the 0 dB (1.0 V) position. If the reference input sensitivity of the connected amplifier is higher, you can decrease the meter sensitivity 20 dB by pulling the associated METER SENS switch. In such a case, the meter will turn to red at a signal level of 10 V (the pointer will read 0 dB). The maximum usable output level of the TAE-8450 is 14 V.

**REC OUT**... The REC OUTput signal level is indicated. The PEAK or PEAK HOLD indication of the REC OUT signal is essential for record level adjustment; observe the relative readings of the Peak Program Meter on the preamplifier and the VU on the recorder. Even if the VU meter reading does not reach 0 VU, the complex musical waveforms may instantaneously exceed the threshold level of the recording amplifier of the tape recorder and cause distortion, so always use the Peak Program Meter as the primary reference.

**Note:** In some cases, the reference level of the VU meter on the recorder may not coincide with that of the TAE-8450 meter (0 dB = 1.0 V).

### Meter Sensitivity Switch [METER SENS PULL + 20 dB]

This is a dual function control (see "headphone LEVEL control" under GENERAL CONTROL SECTION on page 11). This knob decreases meter sensitivity by 20 dB when pulled out and the true reading becomes  $-30$  dB to  $+25$  dB. Any output level is thus actually 20 dB higher than the reading indicated. This feature is useful when operating conditions with particular equipment result in an annoying "in the red" operation.

**Note:** If you pull this knob during PEAK HOLD mode use, it will take some time for the meter to register the true values.

# OPERATING INSTRUCTIONS

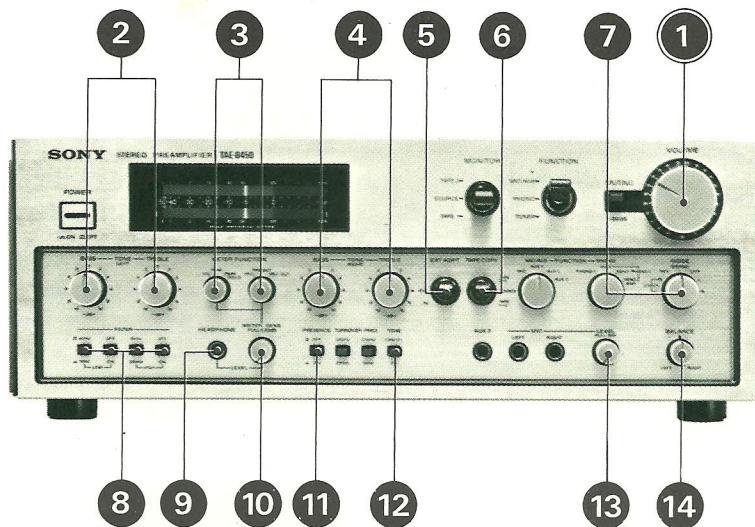

## INITIAL OPERATION

As a preliminary to initial operation, check that the POWER switch is released (OFF) and plug the TAE-8450 into a suitable power outlet.

Before proceeding to any type of operation, set the controls and switches as follows. The controls are listed in the order of panel layout from left to right.

- |                     |  |
|---------------------|--|
| 1. VOLUME           | -at or near minimum position                                 |
| 2. TONES (LEFT)     | -both BASS and TREBLE set to zero                            |
| 3. METER FUNCTIONS* | -left knob to <b>PEAK</b> , and right knob to <b>PRE OUT</b> |
| 4. TONES (RIGHT)    | -both BASS and TREBLE set to zero                            |
| 5. EXT ADPT*        | - <b>OUT</b>   |
| 6. TAPE COPY*       | - <b>SOURCE</b>  |
| 7. MODE*            | - <b>STEREO</b>  |
| 8. FILTERS          | -both LOW and HIGH switches released (OFF)                   |
| 9. HEADPHONE        | -no phones plugged in  |
| 10. METER SENS      | -depressed   |
| 11. PRESENCE        | -released (OFF)  |
| 12. TONE CANCEL     | -released (CANCEL)   |
| 13. MIC LEVEL*      | - <b>depressed</b>   |
| 14. BALANCE         | -center  |

\* During normal operation these knobs should be kept as listed above. If you want to change their settings, refer back to the corresponding items of the "TAE-8450 FRONT PANEL FACILITIES" on pages 11, 12 and 14 to check the function of the new position.

Now depress the POWER switch to ON. Before operating the controls on the TAE-8450, allow approximately 3 seconds for warm up.

After you have become familiar with the operation of the preamplifier, you will find that most of the controls will remain at the same position, and very little manipulation will be required in the course of normal operation as listed in the "PROGRAM SELECTION" on next page.

However, a simple operating habit is worth developing—lower the VOLUME each time you turn on or shut down your system and there is no possibility that you or someone else will "blast" or injure the speakers when the system is turned on.

## PROGRAM SELECTION

Program	MONITOR	Upper panel master FUNCTION	Lower panel FUNCTIONS
Record playing	SOURCE	PHONO	PHONO 1, PHONO 2 or PHONO HEAD AMP*1
Fm/a-m tuner		TUNER	Any position
Auxiliary sources		MIC/AUX	AUX 1, 2 or 3
MIC sound only			MIC
Line-and-mic mixing*2		Proper position for the desired line program (phono, tuner or aux)	
Tapes	TAPE 1 or 2	Any position	

\*1: For record playing observe the proper IMPEDANCE and SENSITIVITY switch settings (refer to page 8).

\*2: For mixing tape and mic programs, reconnect the tape recorder outputs to the AUX inputs.

## SOUND ADJUSTMENTS

Now your TAE-8450 is ready for operation. Turn the VOLUME control clockwise while observing the meters (for meter functions, refer back to page 14). Adjust the BALANCE, TONE, FILTERS and PRESENCE switches to your preference. Use the MUTING switch if required. For mic amplification or line-and-mic mixing, be sure to read the following "NOTES ON MIC USE".

## NOTES ON MIC USE

- To activate the mic signal path, be sure to pull out the MIC LEVEL control and adjust the volume by turning the MIC LEVEL and VOLUME controls. When this knob is depressed the mic signal path is shut off.
- During mic amplification and mixing, be sure to keep the right METER FUNCTION knob at the PRE OUT or REC OUT position. With MIC setting (this position should be used only for room acoustic check), the mic sound will be shut off.
- The extended dynamic range of the mic amp assures distortion-free amplification in normal mic use. But if the mic signal level is extremely high, possible mic amp distortion can be checked as follows: Set the right METER FUNCTION knob to REC OUT. Pull out the METER SENS switch to extend the meter range. Pull and turn the MIC LEVEL knob fully clockwise. If the PPM meter reads over  $-2$  dB (with the METER SENS switch pulled out), the mic amplifier is overloaded and distorting. In such a case lower the MIC LEVEL setting until the meter reads less than  $-2$  dB.
- During mixing, the mic level can be controlled with the MIC LEVEL control and the overall mixing volume can be controlled with the VOLUME control.

# USING THE METERS FOR AUDIO MEASUREMENTS

The accurate Peak Program Meters are useful for measuring the frequency response or channel separation of cartridges, for frequency response measurements and azimuth correction of tape heads, and for checking the room acoustics. Blank graph papers are furnished on page 26 of this booklet to record your test results.

When making cartridge and tape head checks, be sure to turn the power amplifier volume control all the way down to protect the speakers from accidental damage (use headphones).

The TAE-8450 VOLUME control should be kept at one setting for the duration of a particular test.

The TONE cancel switch should be set to CANCEL, and the FILTER and PRESENCE switches should be set to OFF to reproduce the actual response of your sound sources.

## CARTRIDGE CHECKS

The use of a RIAA test record is recommended, since the reproduction characteristic of the TAE-8450 is the inverse of the RIAA standard recording characteristic.

When using a record based on a standard other than RIAA, compensate the test curve for the difference between the RIAA reproduction characteristics and the standard on which the record is based. For details on compensation, refer to the instructions supplied with the record.

### Frequency Response Check

While measuring frequency response, set the METER FUNCTION knobs to PEAK and PRE OUT.

1. Adjust the VOLUME control so that the meter indicates 0 dB for a 1 kHz tone reproduction. Then, reproduce the series of frequency tone bands and read the meters. Plot each output value on graph paper (furnished on page 26 in this manual). Do this for each channel.
2. The RIAA test record is cut to reproduce uniform output (0 dB) from band to band. If there are any variations in output, it will be measured as a deviation from 0 dB level.
3. If the cartridge has very low output and the reading for a 1 kHz reproduction does not reach 0 dB, or if the peak of the frequency response curve goes over +5 dB, set the standard level at a readable position.

### Channel Separation Check

Use a test record that contains left and right channel tones on different bands. When using the PHONO 2 jacks, select proper impedance.

Set the METER FUNCTION knobs to PEAK and PRE OUT.

Set the BALANCE control fully counterclockwise. The left channel PPM meter is to be used.

#### ● Crosstalk from LEFT to RIGHT

1. Reproduce a band which contains only the left channel.
2. Set the MODE selector to STEREO and adjust the VOLUME control so that the left meter reads 0 dB.
3. Move the MODE selector to REV and the left meter will show the crosstalk value from LEFT to RIGHT. Plot the crosstalk value at each frequency.

#### ● Crosstalk from RIGHT to LEFT

1. Reproduce a band which contains only the right channel.
2. Adjust the VOLUME control so that the left-channel meter reads 0 dB (the MODE selector should be placed at REV).
3. Move the MODE selector to STEREO, and the left meter will show the crosstalk value from RIGHT to LEFT. Plot the crosstalk value at each frequency.

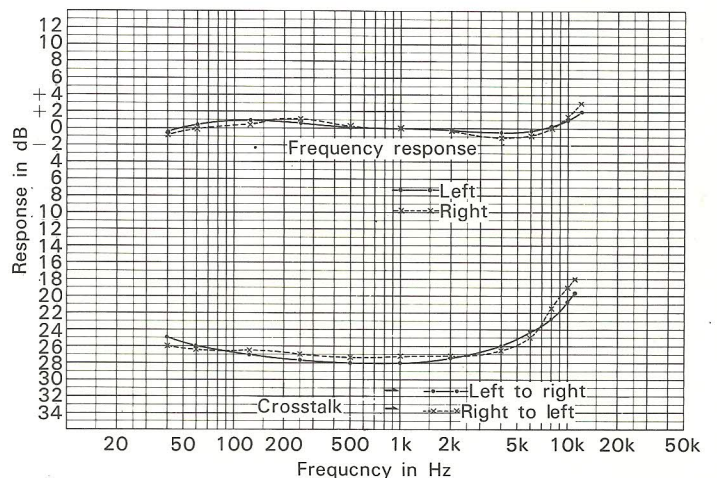

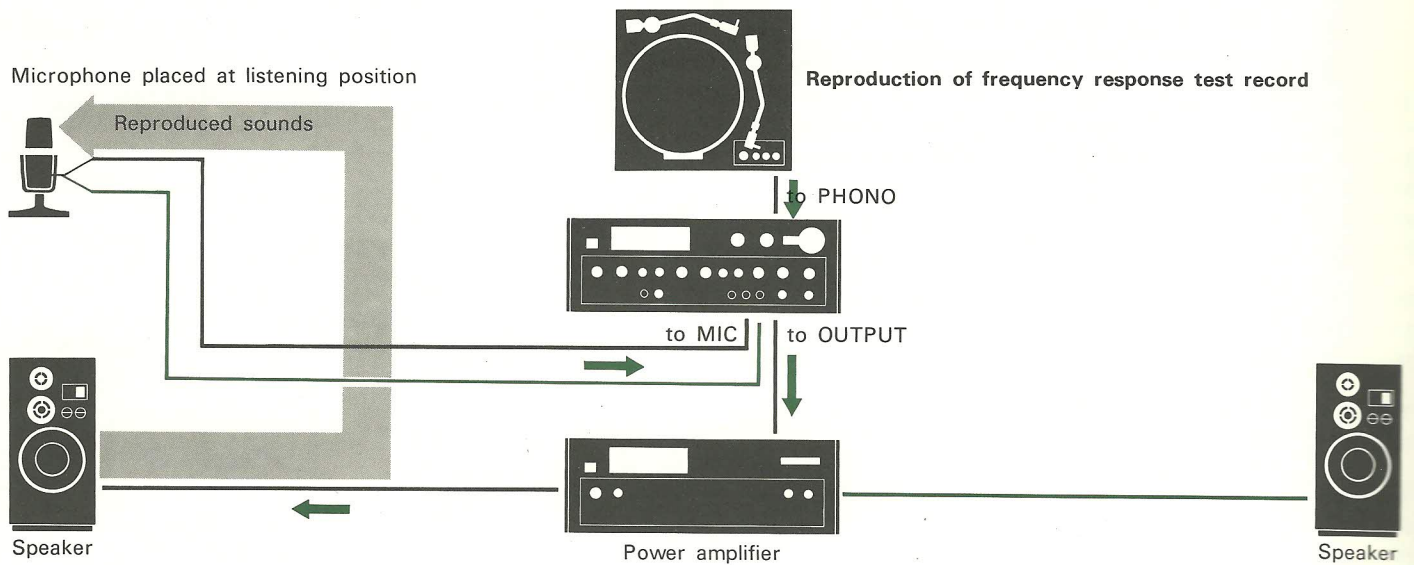

## TAPE RECORDER CHECKS

Use the NAB standard test tape.  
Set the METER FUNCTION knobs to PEAK and PRE OUT.

### Head Azimuth Adjustment

1. Connect the tape recorder output to the TAPE inputs.
2. Use a test tape that contains high frequency tones for azimuth correction. Set the VOLUME control so that the meters show an adequate level for easy reading.
3. While playing the gap-azimuth adjustment tape, slowly rotate the azimuth adjustment screw of the playback head to maximum output level.

### Frequency Response Check

After obtaining the correct azimuth adjustment, check the frequency response of the tape recorder. Use a tape which contains a series of tones.

1. Play back a 700 Hz tone. Adjust the VOLUME control so that the meters indicate 0 dB (the recorded level of the 700 Hz tone is -10 dB).
2. Then reproduce the series of frequency tones and read the meters for each band. Plot each output value on graph paper.

## ACOUSTIC CHARACTERISTICS CHECK

By means of a mic and a suitable test record the acoustic characteristics of your sound reproduction system (including room acoustics) can be checked.

1. Connect a mic to the TAE-8450 and place the mic at your usual listening position.
2. Set the right METER FUNCTION knob to MIC, and set the MONITOR and FUNCTION selectors properly for record playing.
3. Play the test record through the speakers as usual, and adjust the VOLUME to your preference.
4. The reproduced sound will be picked up by the connected mic. While holding the MIC LEVEL control depressed, turn it so that the meter indicates 0 dB reading at 1 kHz.
5. Reproduce the series of frequency tones and read the meter at each band. Plot each value on the graph paper. Compensate the values obtained for the frequency characteristics of the mic.
6. If each value plots 0 dB, the overall acoustic characteristics (including cartridge, preamplifier, power amplifier, speakers, and listening room) are flat. If the curve shows some variation, there are frequency response deviations.

To determine the acoustic condition of the room alone, compensate the curve for the frequency characteristic of the cartridge and the anechoic response of the speaker.

# CARE OF YOUR EQUIPMENT

## TROUBLE CHECKS

If some trouble arises with the operation of the TAE-8450, return to "INITIAL OPERATION" on page 15 for the basic setting of each switch and control. Then check the following chart. It will help in isolating any trouble which you may have with the TAE-8450.

If the trouble persists after you have made these checks, consult your Sony dealer.

The page numbers indicate where additional information may be found.

No audio and the POWER lamp not lit	Check that the ac power cord is plugged into a working outlet.
No audio but the POWER lamp lights.	Check the EXT ADPT switch setting (page 12). Check the settings of MONITOR, FUNCTION, PHONO or MIC/AUX controls (page 12). Check source equipment connections (page 8).
Low sound level	Set the MUTING switch to OFF.
Unbalanced left and right volume	Adjust the BALANCE control. Check the level control settings of the power amplifier.
Unbalanced level between TUNER, TAPE and AUX inputs	Use the appropriate input LEVEL ADJUST control (page 9).
No sound during mic use or no mixing	Pull and turn the MIC LEVEL knob. Set the right METER FUNCTION knob to PRE OUT or REC OUT (page 14).
No recording of source program	Set the TAPE COPY selector to SOURCE.
No tone control adjustment	Set the TONE cancel switch to ON.
Too low meter reading	Depress the dual function switch of METER SENS.
Speakers work but meter inoperative (except for mic playing)	Set the right METER FUNCTION knob to PRE OUT or REC OUT (page 14).
Disc program sound level is too low or high and distorted	Change the PHONO SENSITIVITY switch setting.
Reversed left and right sound	Check MODE selector setting.
Severe hum or noise	Use shielded connecting cord. Keep connecting cords away from transformers or motors, and at least 10 feet from TV sets and fluorescent lights.
Rustling sound	Make secure connections. Wipe the plugs and jacks with a cloth lightly dampened with methanol.

## CLEANING

Clean the cabinet, panel and knobs periodically with a soft cloth. If finger prints, food and beverage stains, etc. are difficult to remove, use a cloth moistened with a mild soap solution. Do not use any type of scouring powder, abrasive pad or solvent.

## REPACKING FOR SHIPMENT

When shipping the unit for repair work or to another location, the unit should be repacked in the original carton and packing material just as before.

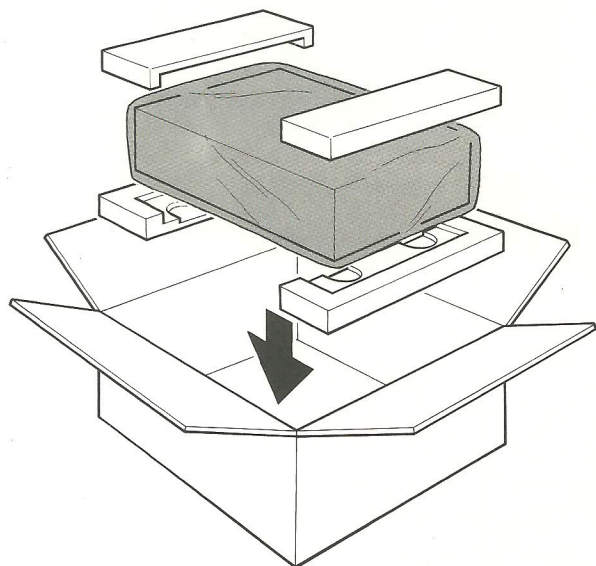

## TECHNICAL DATA

### BASIC DESIGN OF THE TAE-8450

#### The Unit Amplifier

The foundation upon which the design of the TAE-8450 is based is a newly developed "unit amplifier". These are used throughout the preamplifier in the equalizer, flat amplifier and tone control amplifier stages. Using direct-coupled circuitry with a high degree of negative feedback, these building block amplifiers have been developed to the ultimate, and provide a flat frequency response from dc to 100 kHz, with exceptionally low levels of transient and phase distortion, and a wide dynamic range with a gain of 20 dB. The harmonic and intermodulation distortion is immeasurably low.

In combination, these characteristics result in the outstanding performance delivered by the TAE-8450.

#### Low Noise Head Amp Stage

The head amp stage uses newly-developed low noise NPN transistors which provide an especially superior signal-to-noise ratio when driven by a low impedance signal source. Because of this inherent characteristic, this circuit has great noise reduction advantages when used with low level and low impedance cartridges such as those of the moving coil type.

#### Accurate Phono Equalization

The equalizer block consists of two stages; one covers the frequencies below 1 kHz and utilizes a large amount of negative feedback for equalization. The other covers the frequencies above 1 kHz and utilizes an RC network for equalization. This two-stage construction results in very accurate equalization at the low and high ends, extremely low harmonic and IM distortion, and high input capabilities. The use of a unit amp allows direct connection of phono cartridges to the equalizer stage, obviating the need for input capacitors. This presents a constant impedance to the cartridge over its complete operational range, and prevents any degradation of the inherent cartridge response.

#### Two Stage Phono Equalization

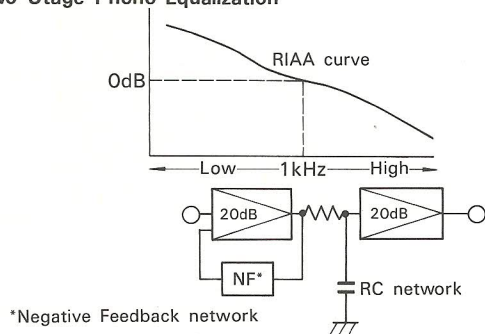

### THE PEAK PROGRAM METER

The advantages of a peak reading program meter are well known in the audio field, but its application up to now has been limited to expensive equipment such as recording studio mixers or broadcast station consoles, because of cost and complexity. However, the Sony engineering staff has been able to adopt this type meter to the new TAE-8450 preamplifier by developing a uniquely designed optical Peak Program Meter which combines professional accuracy with a relatively simple and economical design. Since such a meter indicates all instantaneous peaks in the complex input waveform, the system can be monitored to assure that no overload distortion occurs at any time.

The TAE-8450 provides a choice of preamp output, recording output and mic-amp output readings, and a choice of Peak, Peak Hold and VU type readings. The meter response covers the wide range from -50 dB to +5 dB and the calibration is approximately evenly spaced for easy reading. For higher level indications, the meter sensitivity can be reduced 20 dB by the associated knob.

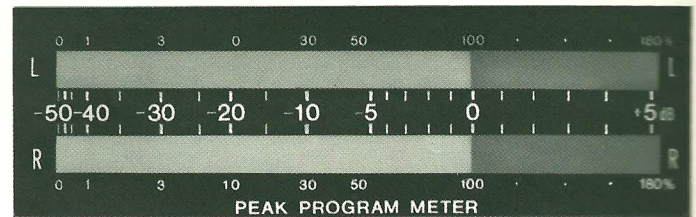

The following figure shows the block diagram of the meter. The input signal is applied to the log-amp which amplifies the signal in a logarithmic fashion to extend the meter response range for ease of reading. Then it goes to the peak detecting circuit which reads both the positive and negative peaks of complex waveforms and selects the highest one. This stage consists of differential amplifiers. The last stage holds the peaks and drives the meter according to the time constants which are selected by the meter mode selector (the left knob under METER FUNCTION).

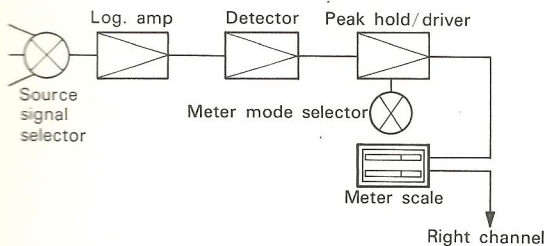

The following figure shows an optical diagram of the meter. After passing through the slit, the light beam is converged on the fixed mirror, then reflects to the meter mirror. Since the meter-mirror angle is controlled by the drive-coil in response to the input signal level, this means that the input signal level is converted to a moving light beam which is projected onto the meter scale and acts as an inertia-free optical pointer.

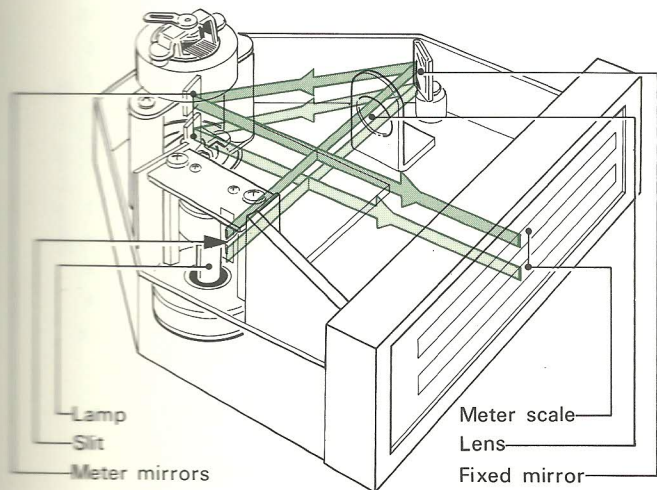

The following figures show the response characteristics in the PEAK and VU modes. Note the response time of each meter. When a 1.0 V signal of 1 millisecond is applied, in the PEAK mode, the meter reads 0 dB (1.0 V) almost instantaneously, while the VU mode can not respond to such transient peaks. When the pulse continues for a certain duration of time as shown in the Figure (300 msec pulse applied), the VU mode reads steady state value at the end of the signal. Thus, as shown in the trace, the PEAK mode is ideal for monitoring transient peaks, and the VU mode is ideal for monitoring average levels for channel balancing or mixing level adjustments.

#### Response Characteristics in the PEAK and VU mode

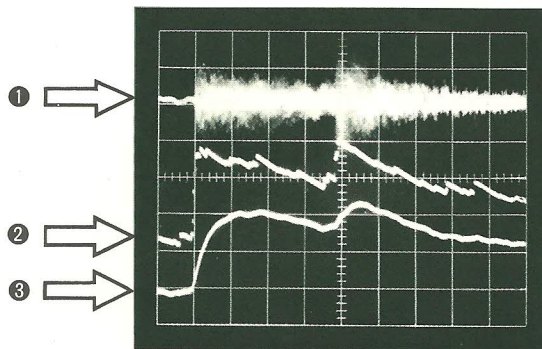
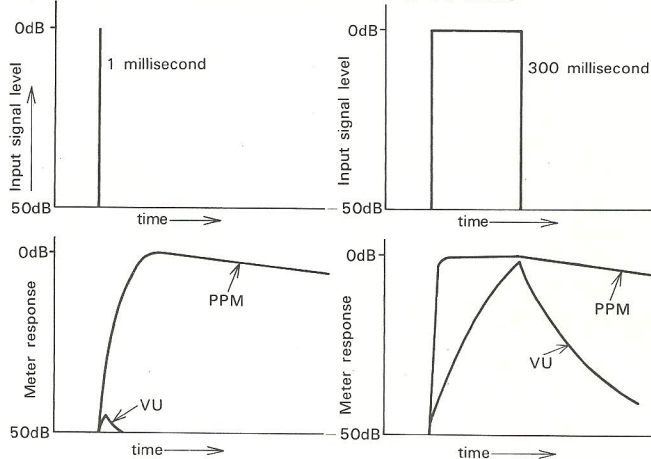

- ① Waveforms of piano sound (from Chopin Scherzo No. 2, B-minor)
- ② PPM response
- ③ VU response

Photo at direct output of PPM drive amplifier

# THE PRECISION STEP ATTENUATOR

To utilize the dynamic range of a preamplifier to the fullest extent, an accurate gain control as well as Peak Program Monitoring is essential. The TAE-8450 step attenuator volume control has been developed to meet this requirement, featuring the use of heavily silver-coated contactors and proven register-printing techniques. This attenuator controls the level from full (at 0 attenuation) to infinitesimal (at -50 dB attenuation) See Figure below. From 0 dB to -34 dB each step provides a 2 dB level change. This is considered to be the minimum loudness change detectable by the human ear. The precision construction provides a deviation of less than 0.5 dB, and  $\pm 0.5$  dB gang error between L and R channels. In addition the 20 dB flat amplifier can be bypassed by depressing the associated muting switch. This facility will also be useful when the direct output of the phono equalizer is desired.

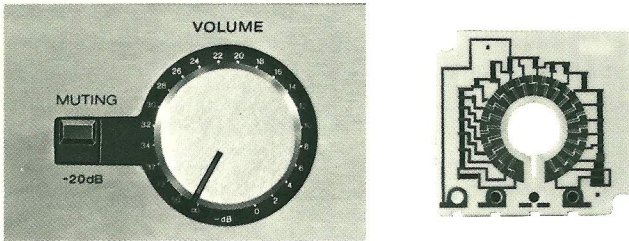

TAE-8450 Step-attenuator Volume Control

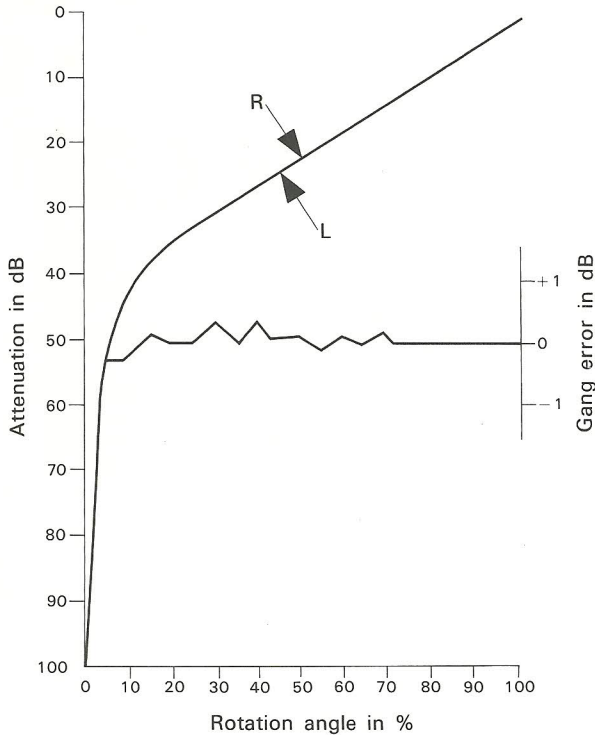

Conventional Volume Control

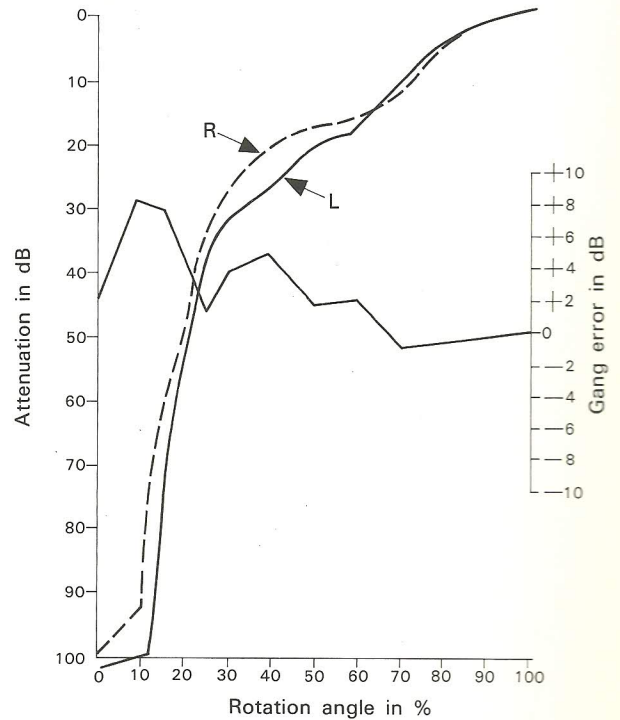

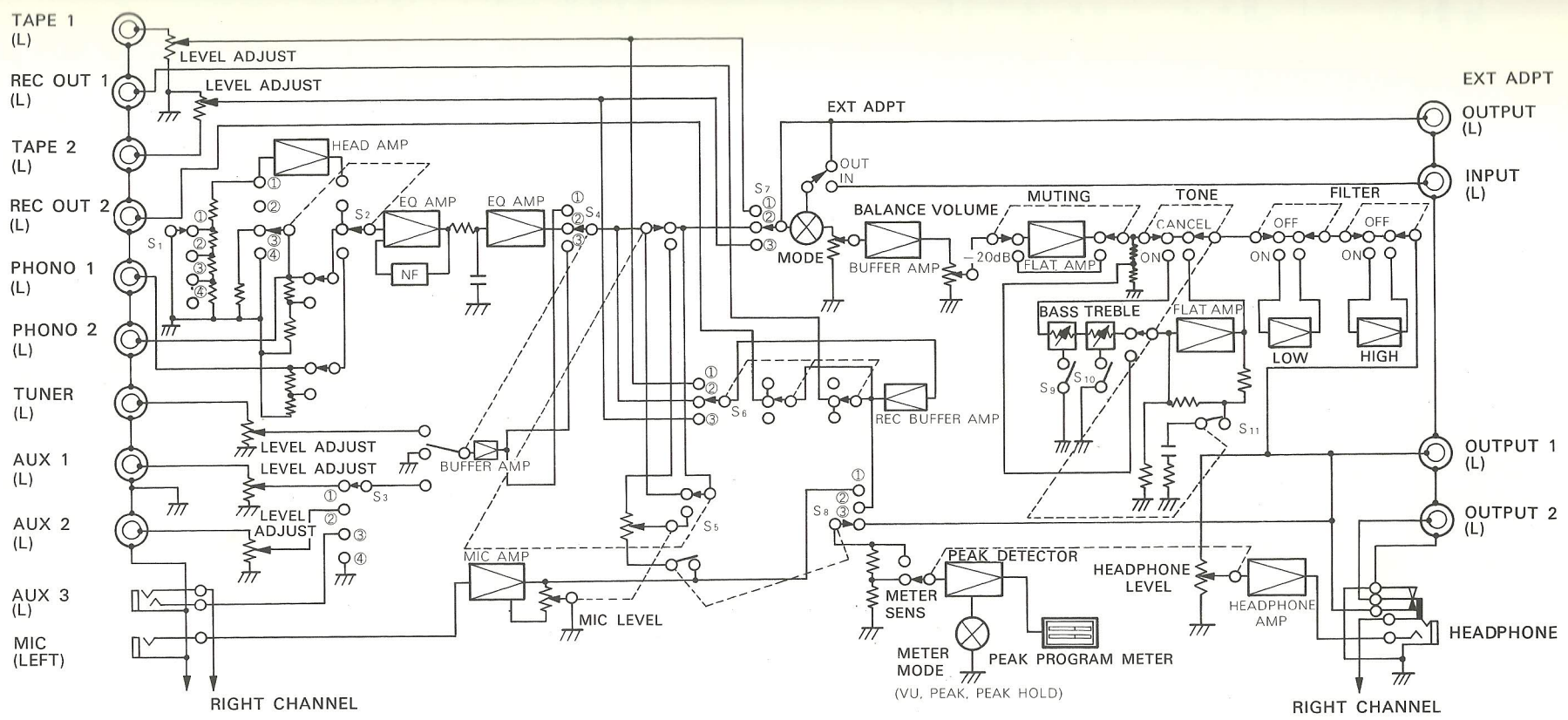

- |  |                             |                               |                                |                                |                                 |                               |
|--|-----------------------------|-------------------------------|--------------------------------|--------------------------------|---------------------------------|-------------------------------|
| <b>S<sub>1</sub>: HEAD AMP IMPEDANCE</b> | <b>S<sub>2</sub>: PHONO</b> | <b>S<sub>3</sub>: AUX/MIC</b> | <b>S<sub>4</sub>: FUNCTION</b> | <b>S<sub>5</sub>: PULL MIX</b> | <b>S<sub>6</sub>: TAPE COPY</b> | <b>S<sub>7</sub>: MONITOR</b> |
| ① 10Ω                                    | ① HEAD AMP                  | ① AUX 1                       | ① TUNER                        |                                | ① TAPE 1→2                      | ① TAPE 1                      |
| ② 30Ω                                    | ② 100kΩ                     | ② AUX 2                       | ② PHONO                        |                                | ② SOURCE                        | ② SOURCE                      |
| ③ 100Ω                                   | ③ 50kΩ                      | ③ AUX 3                       | ③ MIC/AUX                      |                                | ③ TAPE 2→1                      | ③ TAPE 2                      |
| ④ 1kΩ                                    | ④ PHONO 1                   | ④ MIC                         |                                |                                |                                 |                               |
- 
- |                                      |  |                                 |
|--------------------------------------|--|---------------------------------|
| <b>S<sub>8</sub>: METER FUNCTION</b> | <b>S<sub>9-10</sub>: TURNOVER FREQ</b> | <b>S<sub>11</sub>: PRESENCE</b> |
| ① MIC                                |  |                                 |
| ② REC OUT                            |  |                                 |
| ③ PRE OUT                            |  |                                 |

# SPECIFICATIONS

Inputs :

	SENSITIVITY *	IMPEDANCE	MAXIMUM INPUT CAPABILITY (THD 0.1%)	S/N (weighting network, input level)
PHONO 1	1.5 mV 4.5 mV	50 kΩ	140 mV 400 mV	70 dB (A, 1.5 mV)
PHONO 2		50 kΩ/100 kΩ		
(HEAD AMP)	0.16 mV	10 Ω, 30 Ω, 100 Ω, 1kΩ	13 mV	60 dB (A, 0.16 mV)
MIC	0.16 mV	50 kΩ	1.2 V	50 dB (B, 0.16 mV)
TUNER	150 mV	50 kΩ		90 dB (A, 150 mV)
AUX 1 · 2 · 3				
TAPE 1 · 2				
EXT ADPT				

\* The sensitivities of TUNER, AUX 1, AUX 2, TAPE 1, TAPE 2, and MIC are adjustable.

Outputs :

	OUTPUT VOLTAGE	IMPEDANCE
REC OUT 1 · 2	150 mV (max. 14 V)	1 kΩ
HEADPHONE	0.5 V (8 Ω headphone) 6 V (10 kΩ headphone)	100 Ω
OUTPUT 1 · 2	1 V (max. 14 V)	1 kΩ
EXT ADPT	150 mV	10 kΩ

Voltage amplification : (at 1 kHz)

INPUTS \ OUTPUTS	REC OUT 1 · 2	HEADPHONE	EXT ADPT (OUTPUT)	OUTPUT 1 · 2
PHONO 1 (1.5 mV)	40 dB	51 dB	40 dB	58 dB
PHONO 2 (1.5 mV)				
HEAD AMP	60 dB	71 dB	60 dB	78 dB
MIC	58 dB	69 dB	58 dB	76 dB
TUNER	0 dB	11 dB	0 dB	18 dB
AUX 1 · 2 · 3				
TAPE 1 · 2				
EXT ADPT (INPUT)				

Harmonic distortion: Less than 0.03% at rated output, 1 kHz

Intermodulation (IM) distortion:

(50 Hz: 7 kHz=4:1) Less than 0.05% at rated output

Frequency response: PHONO 1.2 RIAA equalization curve  $\pm 0.2$  dB

MIC 20 Hz - 20 kHz  $\begin{matrix} +0 \\ -3 \end{matrix}$  dB

TUNER

AUX 1.2.3  
TAPE 1.2  
EXT ADPT ) 10 Hz - 100 kHz  $\begin{matrix} +0 \\ -1 \end{matrix}$  dB

Tone controls:

(7) steps, each 2 dB

BASS control  $\pm 10$  dB at 50 Hz (TURNOVER FREQUENCY 250 Hz)

$\pm 10$  dB at 100 Hz (TURNOVER FREQUENCY 500 Hz)

TREBLE control  $\pm 10$  dB at 10 kHz (TURNOVER FREQUENCY 2.5 kHz)

$\pm 10$  dB at 20 kHz (TURNOVER FREQUENCY 5 kHz)

Filters:

LOW 12 dB/octave below 10 Hz or 40 Hz

HIGH 12 dB/octave above 9 kHz or 20 kHz

Presence control:

+3.5 dB at 1 kHz

Residual noise:

Less than 70  $\mu$ V (with VOLUME set to minimum, TONE flat, FILTERS OFF, PRESENCE OFF)

**Peak Program Meter (at PEAK mode)**

Frequency response: 30 Hz - 30 kHz  $\begin{matrix} +0 \\ -3 \end{matrix}$  dB

Response range: -50 dB - +5 dB (0 dB=1 Vrms) (With the METER SENS switch pulled . . . -30 dB - +25 dB)

Response time: 1 millisecond at PEAK mode

General

System:

Head amplifiers: direct coupling circuits using 1 low-noise NPN+2 PNP transistors.

Equalizer amplifiers: Each channel employs a unit amp which includes differential amplifiers of 2 FETs+2 PNP transistors, a buffer amp of 1 FET+1 PNP transistor, and a regulated power supply of 2 FETs.

Flat amplifiers: Each channel employs a unit amp similar to that of the equalizer amp.

Headphone amplifiers: pure complementary direct coupling circuit using 1 IC.

Mic amplifiers: 1 IC

Meter amplifiers: log amplifier using 1 Dual-FET+1 PNP transistor,

a rectifier circuit of 1 Dual-FET+2 PNP transistors,

a peak-hold/meter-drive circuit of 4 NPN+1 PNP transistors

Power requirements:

120 V ac, 50/60 Hz

Power consumption:

20 watts

Air outlets:

2 switched 400 watts, 1 unswitched 400 watts

Dimensions:

17  $\frac{3}{8}$  (w)  $\times$  6  $\frac{3}{4}$  (h)  $\times$  13  $\frac{3}{8}$  (d) inches

Weight:

26 lb (net)

31 lb 5 oz (in shipping carton)

Supplied accessories:

Connecting cords (pin plugs to pin plugs) 2

Connecting cord (binaural phone plug to pin plugs) 1

Shorting plugs 4

Design and specifications subject to change without notice.

# OWNER'S TEST DATA

These pages of blank graph paper may be used for recording the results of personal checks of various components used in association with the TAE-8450 preamplifier.

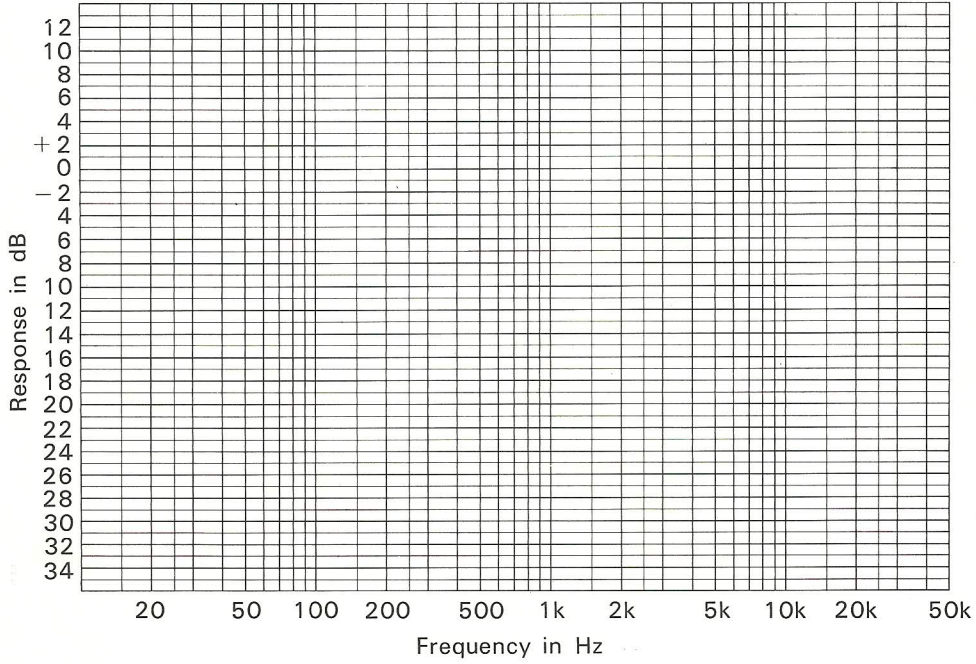

Subject :  
Test record or tape :  
Equipment :  
Date :

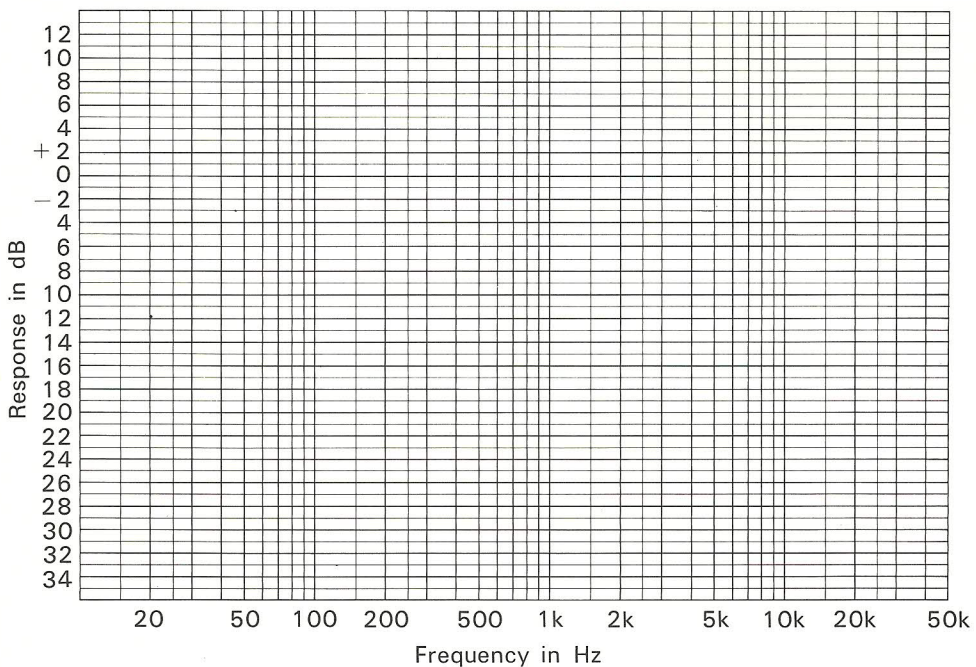

Subject :  
Test record or tape :  
Equipment :  
Date :

# NOTE

TAE-8450

Your TAE-8450 is factory-preset at 220 volts ac.  
To operate on the voltages other than 220 volts ac, reset the voltage selector on the rear panel as follows:  
Be sure that the ac power cord is disconnected from the power supply before proceeding.

- ① Loosen the arrow-marked screw on the selector cover, and remove the other screw.
- ② Unplug the selector and reinsert it firmly with the arrow mark pointing to the proper voltage figure.
- ③ Replace the selector cover.

Please disregard the sentence "Operate the amplifier only on 120 volts ac 60 Hz (described on page 3 in the manual)".

Some of the specifications (described on page 25) are changed as follows:

Power requirements 100, 120, 220 or 240 volts ac, adjustable,  
50/60 Hz  
Power consumption 22 watts

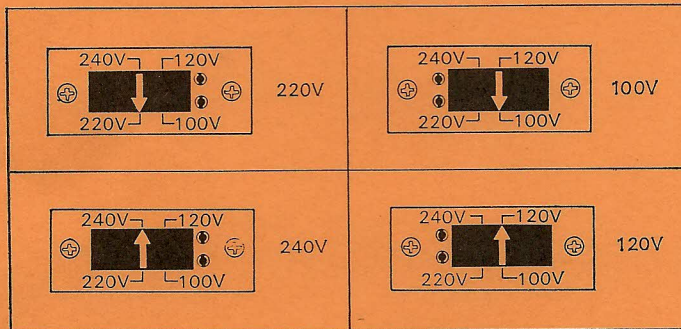
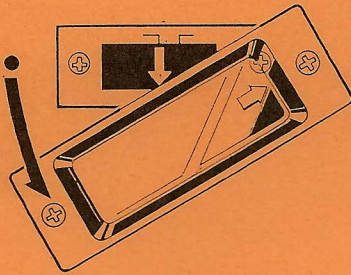

STEREO PREAMPLIFIER TAE-8450

SONY®

VISUAL INSPECTION OK

SERIAL NO. 400008

PLAYING TEST OK

INSPECTOR S. Miyazawa

ELECTRICAL TEST

	FREQUENCY RESPONSE		SENSITIVITY (1 kHz)		S/N (IHF)		HARMONIC DISTORTION (Rated output)	
	L	R	L	R	L	R	L	R
PHONO 1			Less than		75.0 dB	75.0 dB	0.023%	0.026%
PHONO 2	RIAA		1.5 mV	<u>OK</u>	75.5 dB	75.0 dB	0.023%	0.026%
(HEAD AMP)		<u>OK</u>	0.16 mV	<u>OK</u>	64.0 dB	64.0 dB	0.023%	0.026%
MIC	20 Hz		0.16 mV		55.0 dB	55.0 dB		
	-0.8 dB	-0.6 dB						
PEAK PROGRAM METER INDICATION	20 kHz							
	-1.2 dB	-1.5 dB						
AUX 1, AUX 2, AUX 3, TAPE 1, TAPE 2, TUNER EXT. ADPT	30 Hz		150 mV		95.0 dB	95.0 dB	0.016%	0.016%
	-2.7 dB	-2.5 dB						
	30 kHz							
	-1.9 dB	-1.9 dB						
	10 Hz							
	-0.1 dB	-0.1 dB						
	100 kHz							
	-1.0 dB	-1.0 dB						

# TAE-8450 SIGNAL-FLOW DIAGRAM



FM/AM TUNER

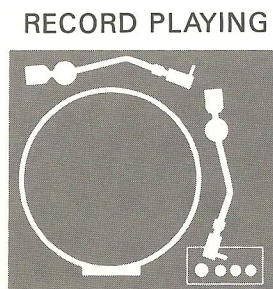
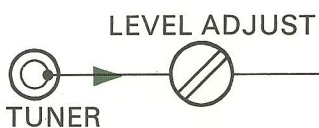

RECORD PLAYING

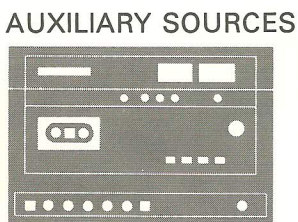
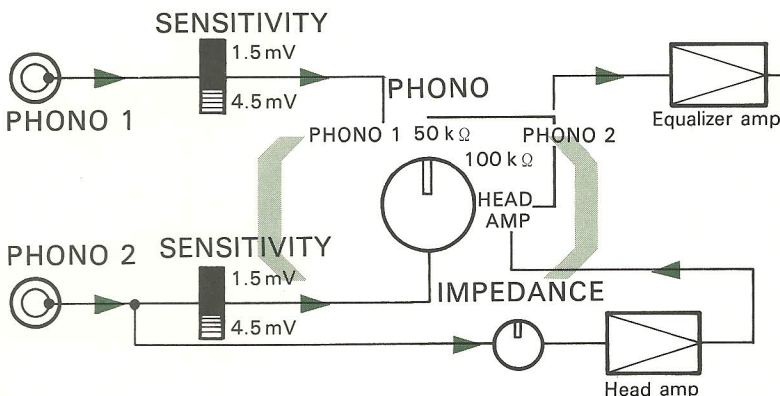

AUXILIARY SOURCES

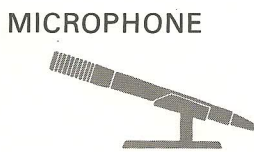
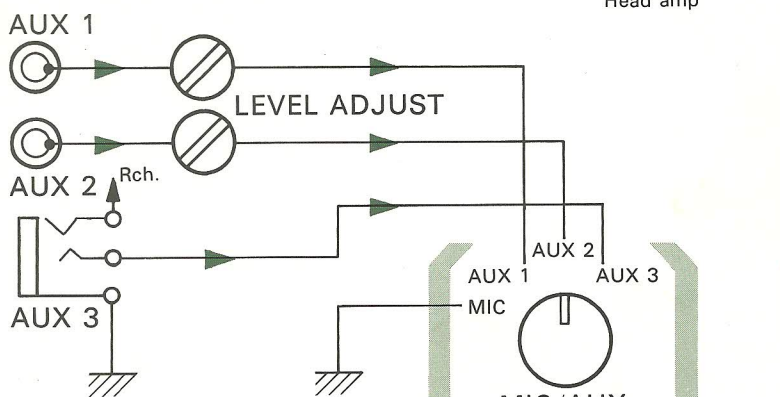

MICROPHONE

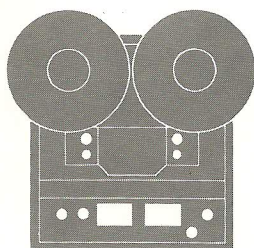

TAPE PLAYBACK OR RECORDING

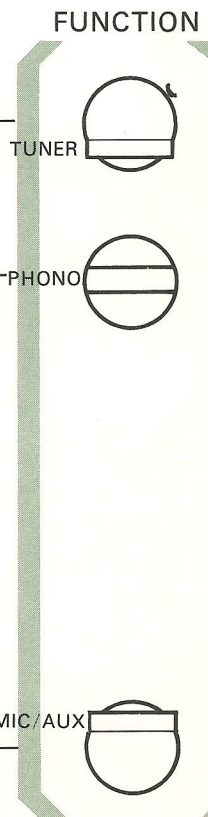
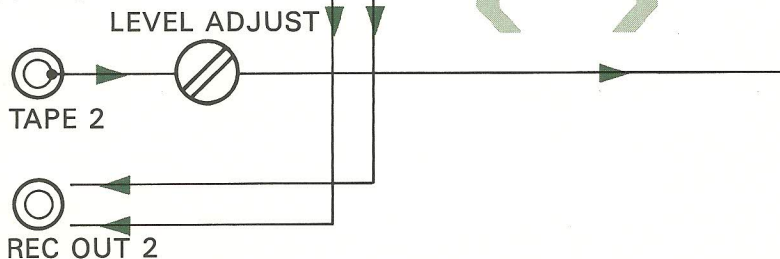
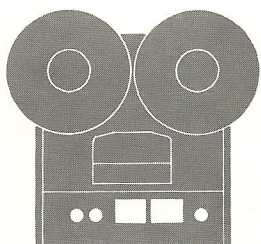
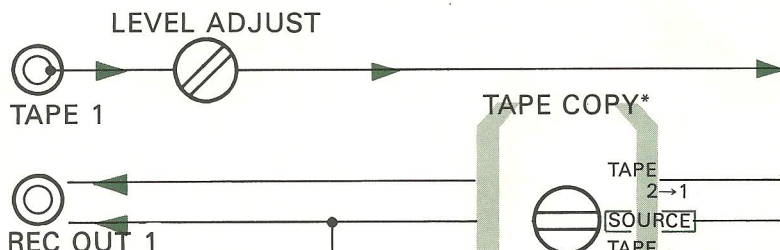

This signal-flow diagram, a simplified version of the block diagram in the instruction manual, will help you understand how the TAE-8450 works from inputs up to outputs.

Switches marked \* should be usually set to the  position. Before changing the position of these switches, be sure to familiarize yourself with their functions as described in the manual.

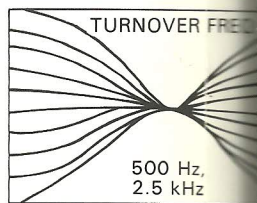
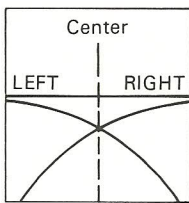
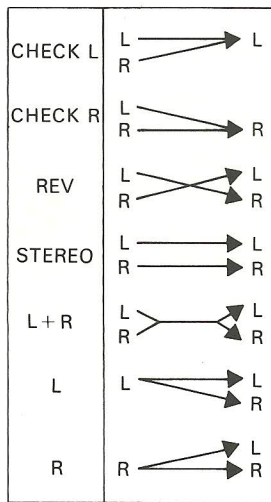
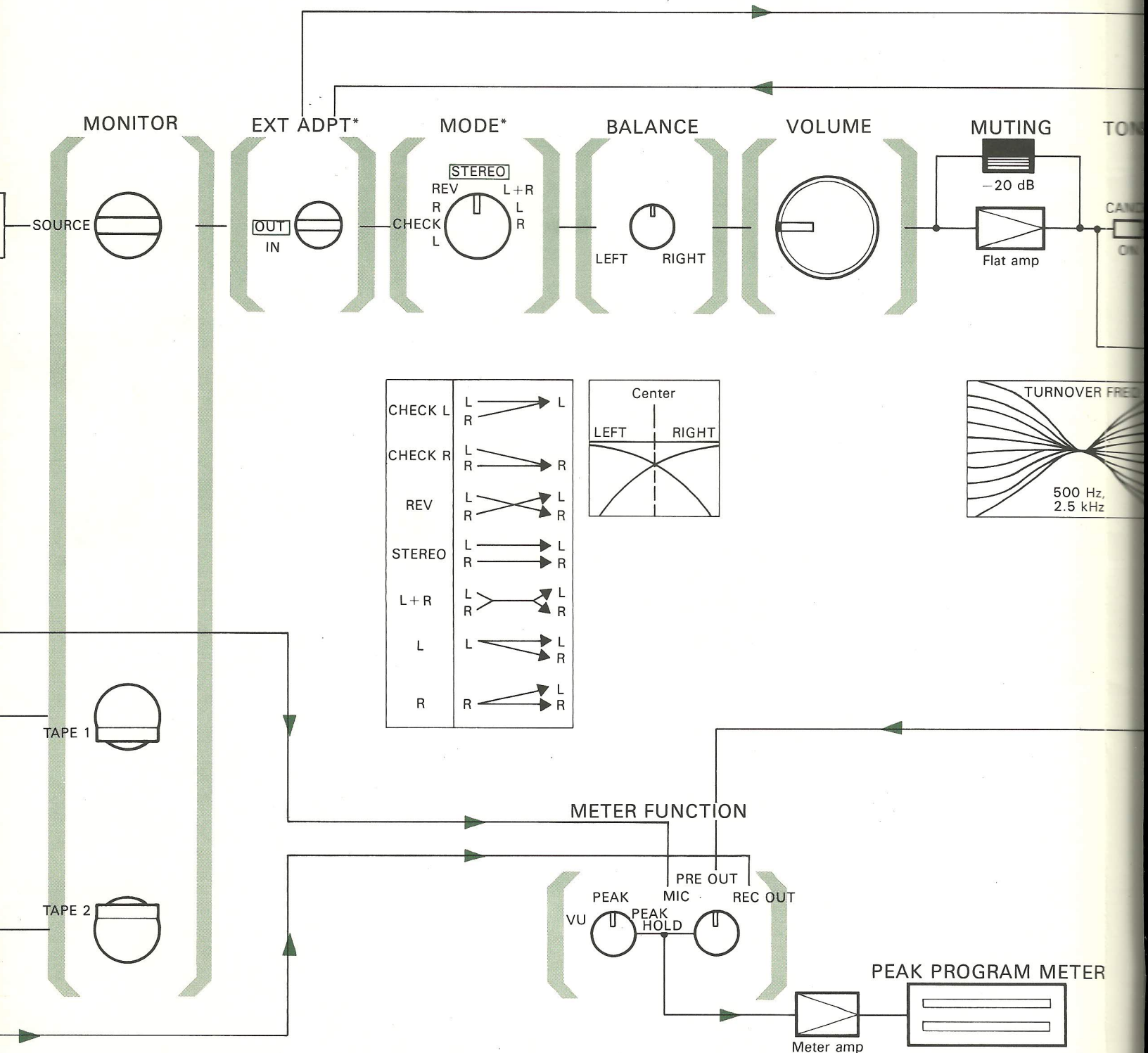

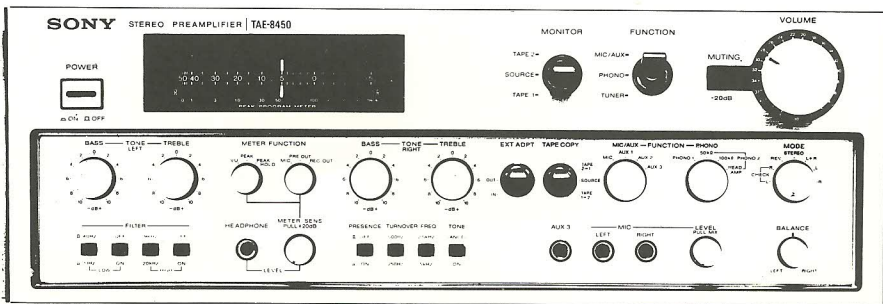
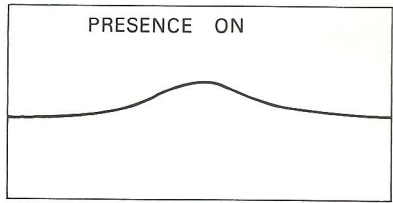
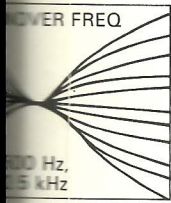
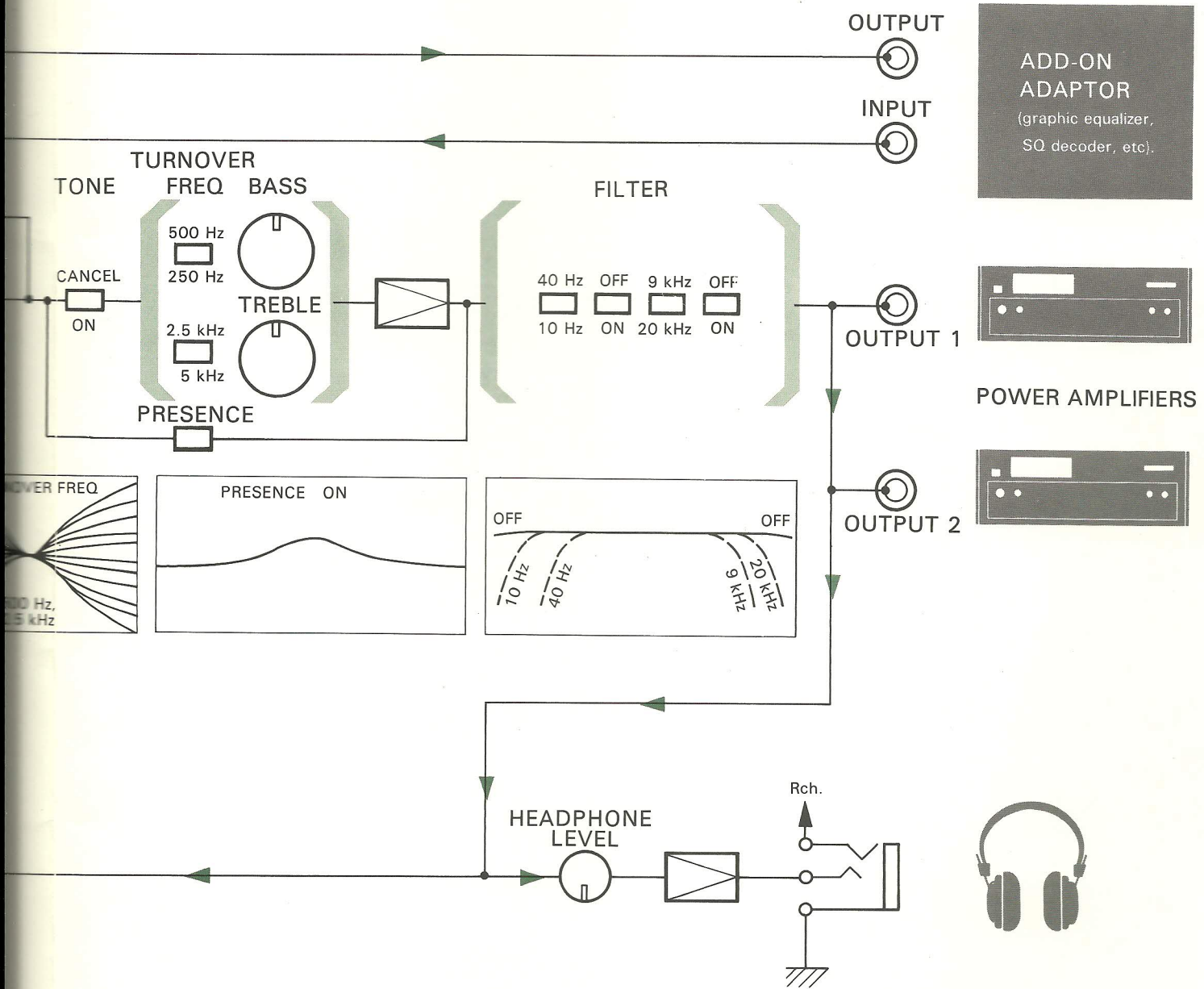

**ADD-ON ADAPTOR**  
(graphic equalizer, SQ decoder, etc.)

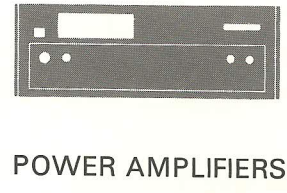

Sony Corporation  
3-793-766-21 (1)  
Printed in Japan ©