



For more Hi-Fi manuals and set-up information  
please visit [www.hifiengine.com](http://www.hifiengine.com)

SONY®

SOLID STATE  
**STEREO AMPLIFIER**  
**TA-3200F**

OWNER'S INSTRUCTION MANUAL

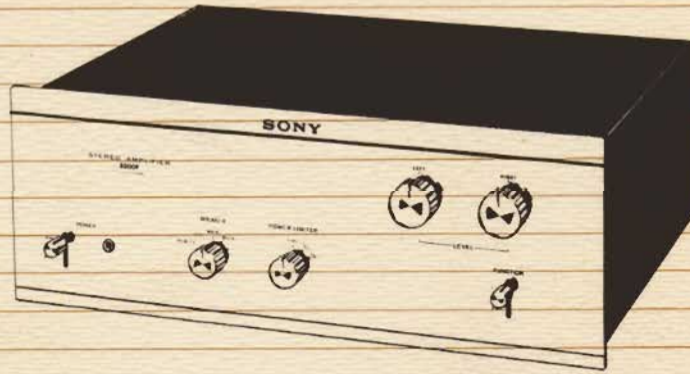

The SONY TA-3200F is an amplifier designed for professionals and those discriminating audiophiles who wish to build a true-fidelity sound-reproduction system. The TA-3200F has 100 watts of rated power output which can drive any speaker system with plenty of reserve for difficult passages. The use of the direct coupling circuit at the speaker output and the selected high-performance silicon transistors provides superior damping factor, extended flat frequency response, and unprecedented low distortion.

Each unit has been thoroughly checked and tested before its delivery to you.

Please take the time to read through this manual completely, so that you can become familiar with the TA-3200F's features and capabilities. Keep this booklet handy for future reference.

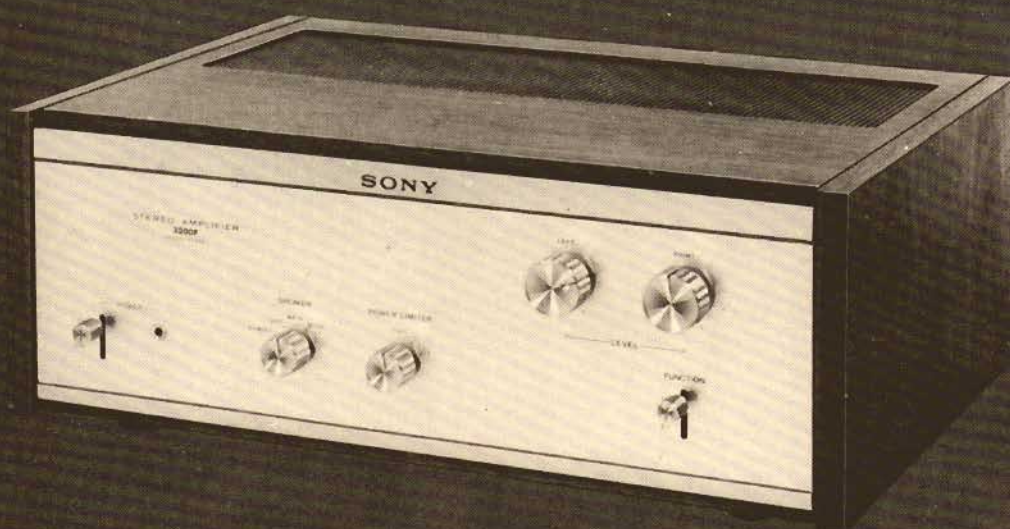

## TABLE OF CONTENTS

<b>PREPARING FOR USE</b> .....	2
UNPACKING .....	2
WARRANTY .....	2
SYSTEM CONNECTIONS .....	2
CUSTOM MOUNTING .....	5
<b>OPERATING INSTRUCTIONS</b> .....	6
LOCATION AND FUNCTION OF CONTROLS AND CONNECTORS .....	6
USING THE TA-3200F IN YOUR STEREO SYSTEM .....	7
<b>CARE OF YOUR EQUIPMENT</b> .....	10
CLEANING .....	10
FUSE REPLACEMENT .....	10
REPACKING FOR SHIPMENT .....	10
<b>TECHNICAL DATA</b> .....	10
TECHNICAL DESCRIPTION.....	10
TECHNICAL SPECIFICATIONS .....	11
OPERATING CURVES .....	12

## PREPARING FOR USE

### UNPACKING

All SONY equipment comes to you carefully packed in cartons designed to withstand the rigors of shipment. Do not throw the carton or associated packing material away; they will come in handy if you ever have to transport or ship the TA-3200F.

Inspect your TA-3200F immediately for signs of damage incurred in transit. If damage has occurred, consult your local SONY dealer for further instructions. Once again, save all packing material; it will substantiate your damage claim.

### WARRANTY

An application for free 3-year factory service warranty is included with the TA-3200F. Fill in the application and mail it within 10 days of the date of purchase.

## SYSTEM CONNECTIONS

No doubt you have already decided on a location for your TA-3200F. However, before going ahead with the installation, make sure that your choice of location agrees with the following list of DO's and DON'T's.

**DO** allow at least one inch clearance around the TA-3200F for ventilation.

**DO** allow sufficient room behind the TA-3200F so you can make connections to the rear panel without disrupting your entire setup.

**DON'T** remove the chassis cover. Refer servicing to qualified personnel.

**DON'T** place the TA-3200F in direct sunlight, or near radiators, hot-air ducts, or any other source of heat. The TA-3200F must not be operated where the room temperature is over 110°F. Similarly, don't place it in any area subject to freezing temperatures or excessive moisture.

**DON'T** place the TA-3200F on any soft surface which may block the bottom ventilation holes. Similarly, don't place anything on top of the cabinet which might block the top ventilation holes.

**DON'T** connect the TA-3200F to power sources other than 117 volts, 60 Hz (cycles) ac. Do not operate the unit where the line voltage is higher than 128 volts.

**DON'T** make connections with the power turned on.

After you have found a suitable location for your unit, you can begin making the basic connections described in the following paragraphs. Refer to the overall-system connection diagram while making these connections.

### Input Connections

Each INPUT terminal accepts the output signal of a preamplifier or a channel-dividing preamplifier. Use low-capacitance shielded cable for input connections. Keep the cables as short as possible.

To use the supplied pin plug, see the illustration below.

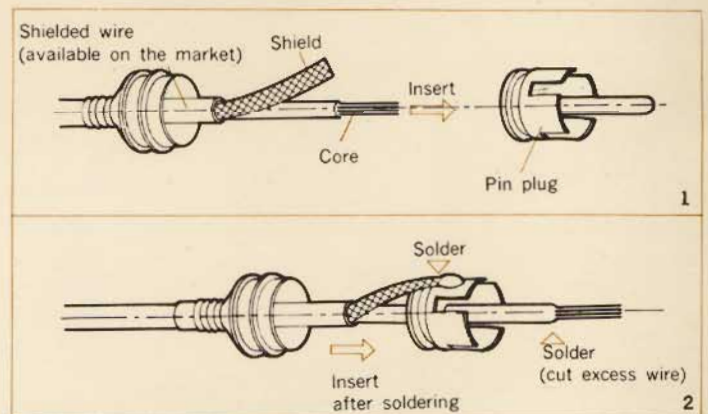

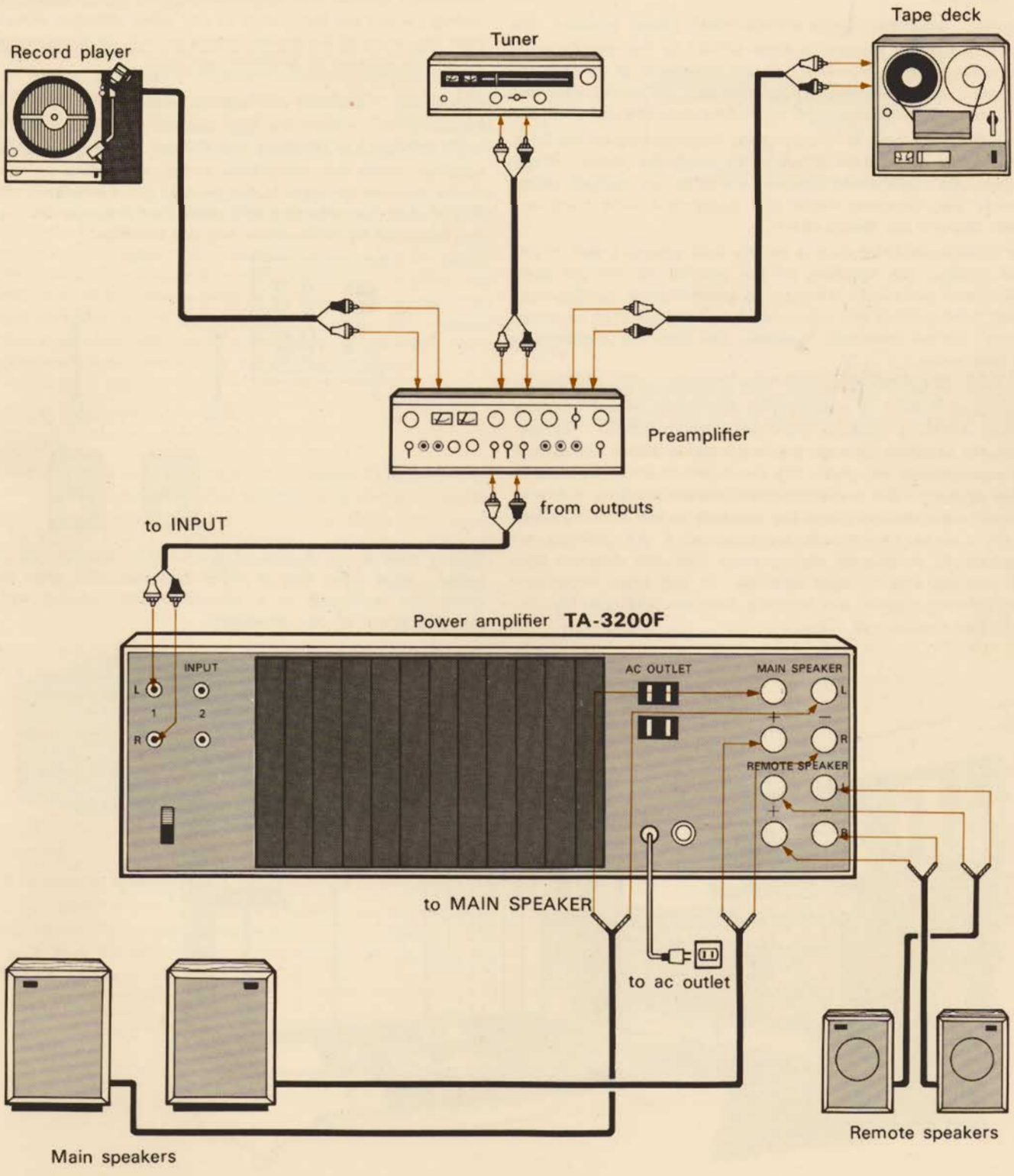

### Speaker Connections

The TA-3200F can drive two speaker systems, main and remote, simultaneously or independently. Both systems are turned on or off with the SPEAKER selector on the front panel. The speakers connected to these terminals should have an impedance of 4-16 ohms.

**Location** In many home-entertainment stereo systems, the choice of speaker location is often limited by the existing furniture arrangement. However, if rearrangement is possible, or you wish to furnish the area specifically for stereo listening, here are a few suggestions for optimizing your listening pleasure. Setup your speakers in a large room having a rug on the floor. If the room has heavy drapery, so much the better. Rugs, drapery, and upholstered furniture minimize the multiple reflections of high-frequency sound that occur in a bare room and which degrade the stereo effect.

The usual speaker location is on the floor against a wall. If you must position the speakers off the ground, do not put them higher than eye-level. Because of psychological conditioning, sound coming from the vicinity of the ceiling gives an unnatural feeling. Corner locations, however, are ideal for emphasizing the bass notes.

The distance between the right- and left-channel speaker system in a stereo system is important to the stereo effect. Closely-spaced speakers produce minimum stereo effect. Widely-separated speakers produce maximum stereo effect, although if the separation is too great, the unnatural "hole-in-the-middle" effect appears. The proper distance between speakers is directly related to the distance from the speakers to the listening areas. In most cases, fine results are obtained if the speakers are separated by an amount slightly more than the distance from the listening area to each speaker. In any case, experiment with different speaker and listening locations until you find the setup that pleases you most.

**Cable Type** The type of wire used to connect the speakers to the amplifier is not critical in most home stereo systems. Ordinary dual-conductor lamp cord is often used for this purpose. Ordinary 18-gauge lamp cord is fine for short runs. However, 14- to 16-gauge wire may be needed for long runs to low-impedance speakers to prevent excessive power losses in the wiring. If you use lamp cord or any other stranded wire, make sure that none of the strands separates from its group and shorts across the speaker or amplifier terminals.

**Connection** Connect your speaker system to the MAIN SPEAKER terminals. Connect the right and left speakers to the RIGHT and LEFT speaker terminals respectively. To properly phase the speakers, make the connections so that the positive (+) terminal of the speaker connects to the positive (+) terminal of the TA-3200F, and the remaining lead of the cord connects the negative (-) terminals on the speaker and the amplifier.

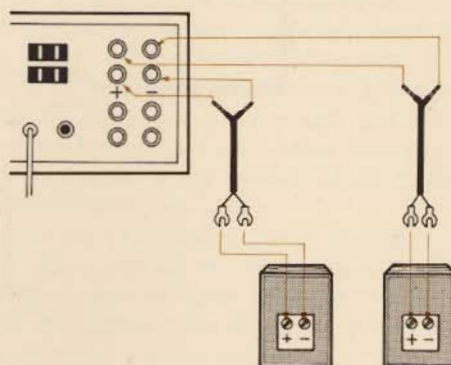

This is easy to do if one of the wires in a lamp cord pair is coded. Most lamp cord is coded by means of a ridge molded along one conductor, or a colored thread included with the stranded wires of one conductor.

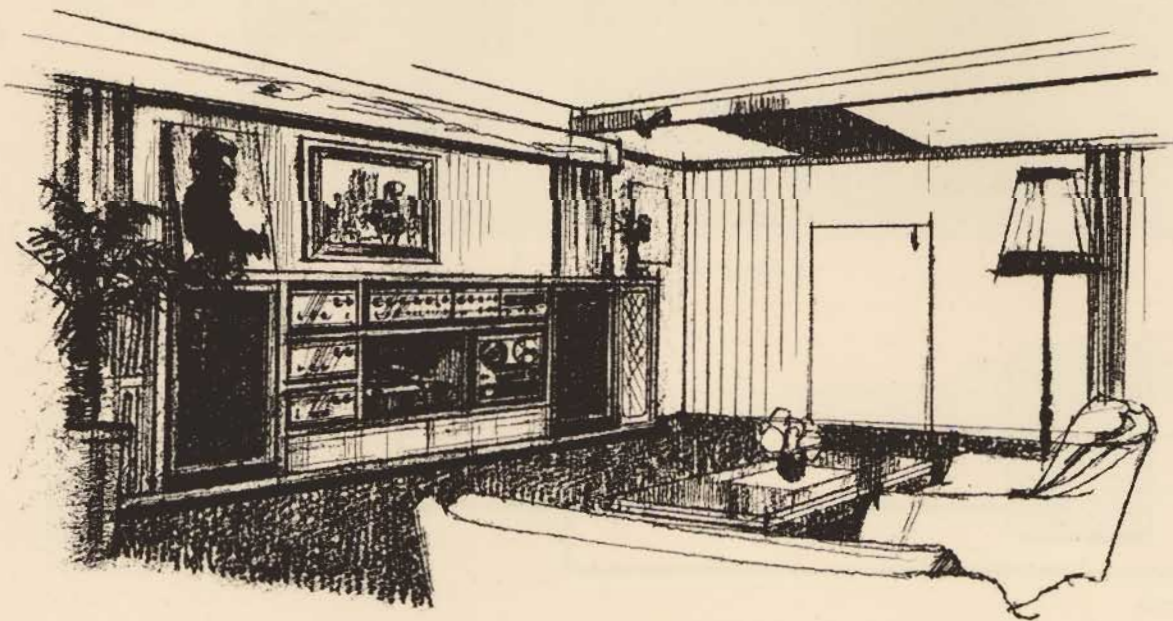



If you are also using remote speakers, connect them to the REMOTE SPEAKER terminals as described previously. Push the top of the speaker terminal and insert a speaker wire into the slot at the upper left of the terminal. Release the top, and the connection is made instantly. To disconnect just push the top again and pull out the speaker wire.

#### Power Connections

Before making any form of power connection, make sure the TA-3200F's POWER switch is set to OFF. Then you can plug the TA-3200F's line cord into the electrical outlet. Once again, let us remind you that the power source must be 117 volts, 60 Hz ac.

Female outlets on the rear apron of the chassis provide a convenient source of ac power for any of your other system components. Equipment plugged into the SWITCHED outlet need not have a power switch; the POWER switch on the TA-3200F controls the ac power to this outlet. Equipment plugged into the UNSWITCHED outlet must have its own power switch; the POWER switch on the TA-3200F does not control the ac power to this outlet. The total power consumption of all equipments plugged into these outlets must not exceed 300 watts.

#### CUSTOM MOUNTING

##### TAC-1 Case

The complete line of SONY Stereo High-Fidelity Components are styled with the same simple but elegant lines so that complete systems can be assembled with a truly unitized appearance. The TA-3200F, the TA-2000 Preamplifier, and the ST-5000FW Tuner are the same size. Therefore, each can fit into a handsome walnut case Model TAC-1, available as an optional accessory.



##### MB-5 Mounting Bracket

If the TA-3200F is to be mounted in a cabinet, use the mounting bracket Model MB-5 (optional accessory). The opening in the cabinet's panel should conform to the dimensions given in the illustration.

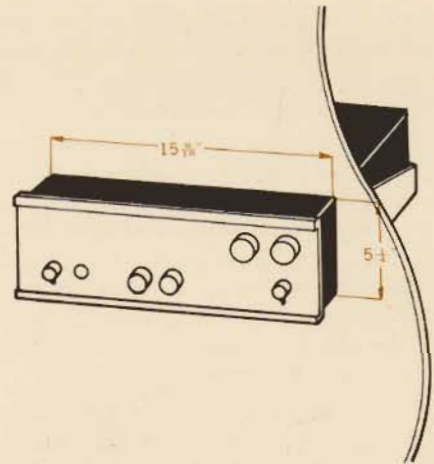

##### Note :

Although the TA-3200F dissipates comparatively little heat. However, take care in the installation that ventilation holes are not blocked and that air can circulate freely around the amplifier.

# OPERATING INSTRUCTIONS

## LOCATION AND FUNCTION OF CONTROLS AND CONNECTORS

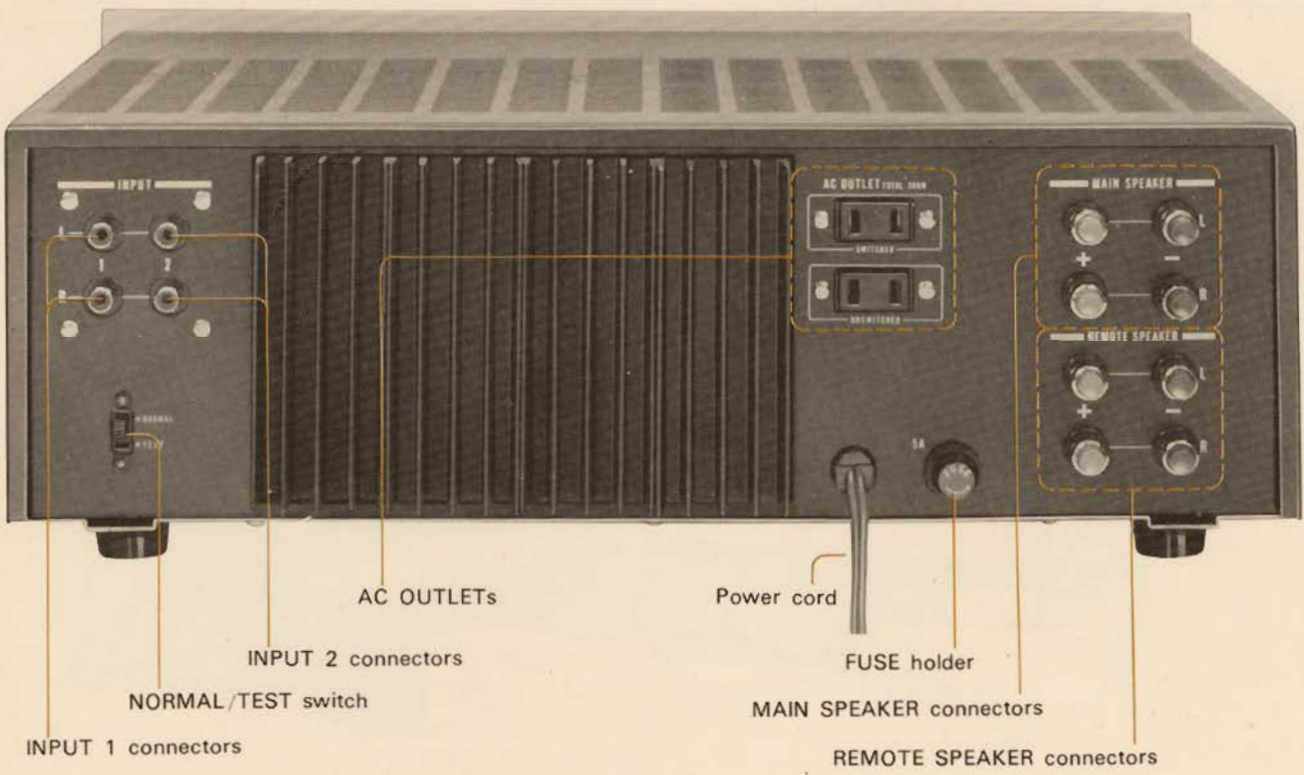
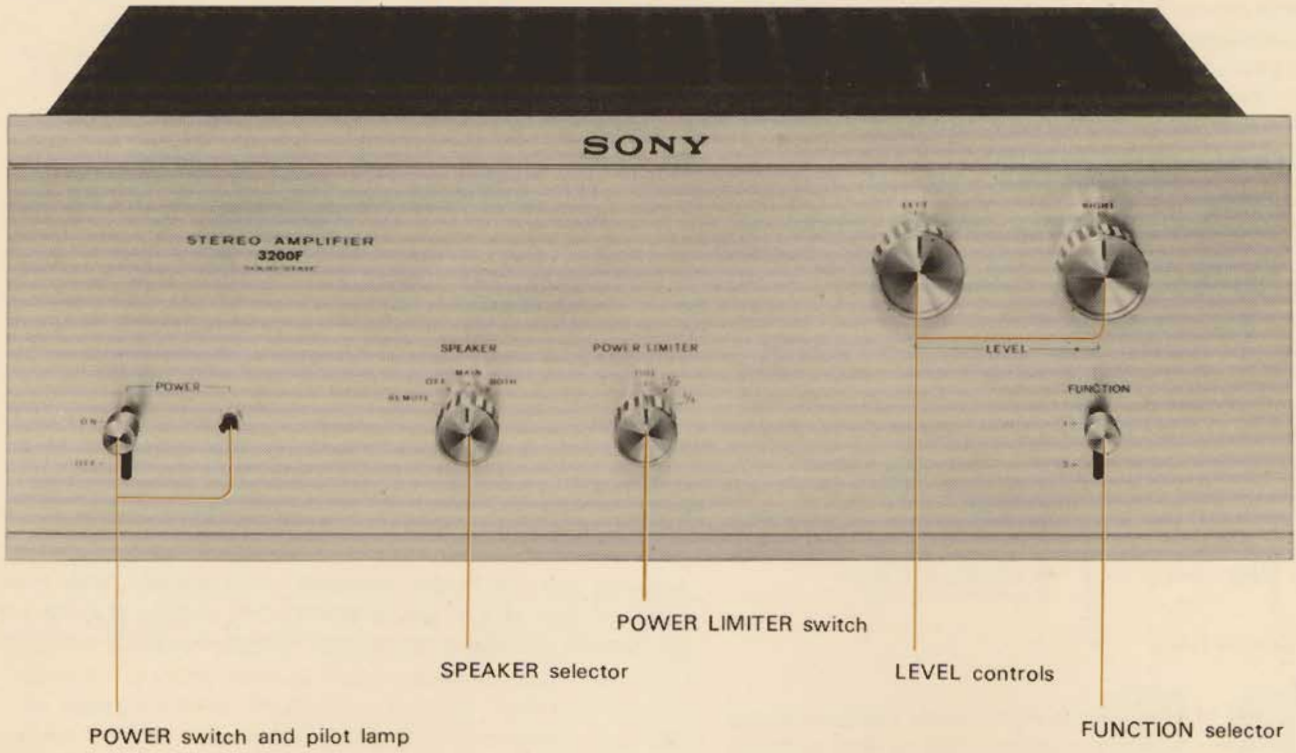

Before attempting to operate your TA-3200F, you will be wise to learn the function and location of the controls, connectors, and other parts mentioned in the operating instructions. The locations are shown in the illustration, and the functions are described below.

#### POWER Switch and Pilot Lamp

Turns the operating power on or off. The pilot lamp lights when the power is on.

When the POWER switch is turned off, the input signal is simultaneously shorted.

#### SPEAKER Selector

Switches the main and remote speakers in or out of the system.

#### POWER LIMITER Switch

The TA-3200F delivers FULL,  $\frac{1}{2}$  or  $\frac{1}{4}$  (per channel) of rated output power. Select the output level according to the power-handling capacity of your speaker system.

#### LEVEL Controls

These controls will be helpful:

- For balancing the sound volume.
- When using a preamplifier which has too high an output level.
- For balancing the output level of each power amplifier in a multichannel-amplification system.

#### FUNCTION Selector

Instantaneous selection of INPUT 1 and INPUT 2 is made with this selector switch.

#### NORMAL/TEST Switch

For normal use set the switch to NORMAL; in this position inaudible frequencies lower than 30 Hz are attenuated at the rate of 6 dB/octave to prevent IM distortion\* at the speaker.

\* If the program signal contains some extremely low frequencies, the pitch of audible frequencies may be affected by the excessive movement of the diaphragm caused by inaudible low frequencies.

For frequency response tests of the TA-3200F or for reproducing frequencies lower than 30 Hz, set the switch to TEST. The TA-3200F will provide flat frequency response to 5 Hz.

#### USING THE TA-3200F IN YOUR STEREO SYSTEM

It is very difficult to obtain faithful reproduction of the full frequency audio range with a single cone-type speaker, because of IM distortion, interference distortion, and/or poor transient characteristics and directivity. The usual solution is to separate speakers for each frequency range. In this system, a crossover network is placed between the power amplifier and the speaker system. The network divides frequencies into 2 or 3 bands for reproduction through the most suitable speakers—a woofer for low frequency, a squawker (mid-range) for medium frequency, and a tweeter for high frequencies.

High-quality speaker systems of this type now on the market are precisely designed and usually have a smooth overall response. However, this type of speaker system may not give full satisfaction to the perfectionist because of the following:

1. Inferior transient characteristics caused by the inductors and capacitors of the crossover network.
2. The crossover frequencies cannot be changed easily.
3. Speaker efficiencies may differ. If the efficiency of the mid-range and high-range speakers is inferior to the low-range speaker, an attenuator is then used with the low-range speaker and the damping factor deteriorates.
4. If the impedance of the cone type speaker changes with the frequency, the crossover network may not work as designed and may cause dips and peaks in the frequency response.

For those who require a more critical sound reproduction system, or wish to combine speakers to suit their personal taste, the Multichannel Amplification System (described on next page) is recommended.

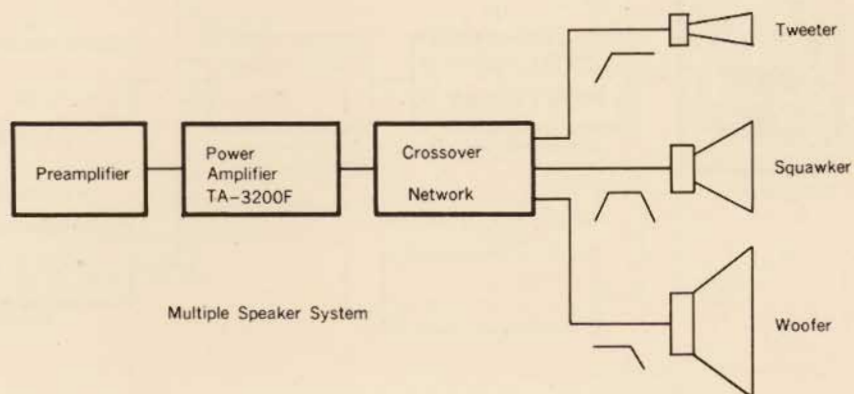



### Multichannel Amplification System

A far superior way of dividing the frequency ranges is to make the division to three separate power amplifiers, rather than at the output of a single power amplifier.

A Multichannel Amplification System consists of a preamplifier, a channel dividing preamplifier and three power amplifiers.

This system provides the following advantage :

1. Accurate crossover frequencies. The cut-off characteristics can be determined regardless of the impedance characteristics of the speakers.
2. Only resistors and capacitors are used to make the crossover network, thus an easy change in crossover frequency can be effected.
3. Level control can be done independently in each frequency range.
4. Damping factor is not affected.

The SONY Stereo Power Amplifiers, TA-3200F, are recommended for use as the power amplifier units in multichannel system. Your nearest SONY dealer will make effective suggestions to set up this system.

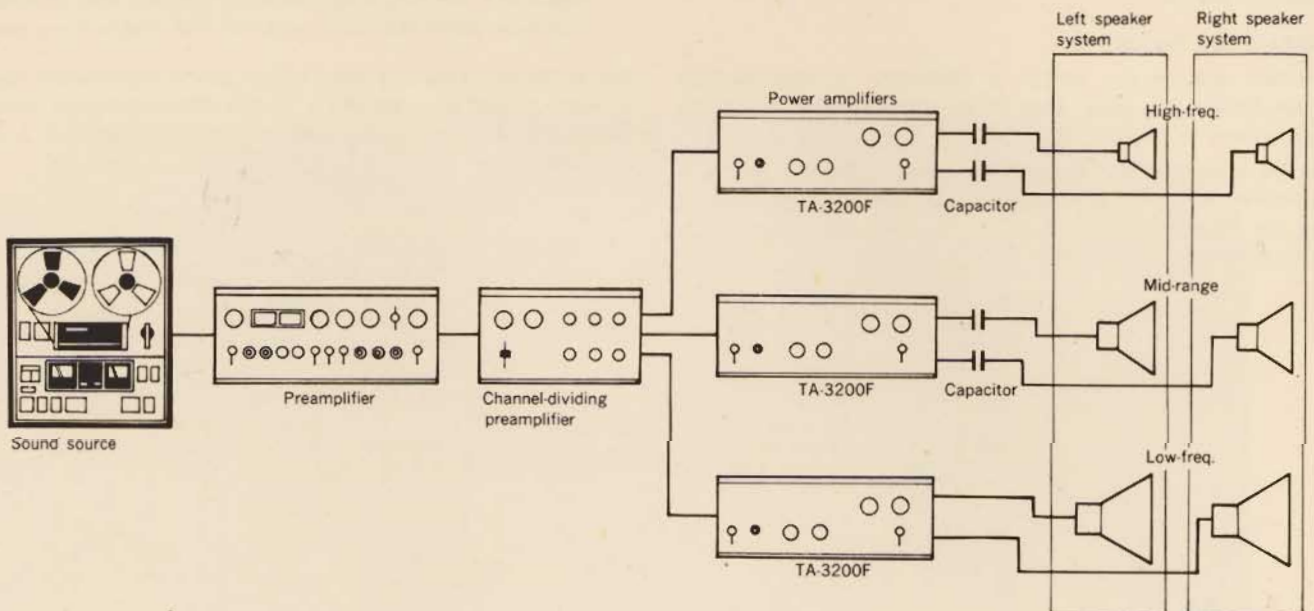

Powerful low-frequency transients occurs if you plug in the connecting cords to the high- and/or mid-range power amplifiers without turning down the LEVEL controls on these amplifiers. This may damage the high- and/or mid-range speakers if they are directly connected to the amplifiers. To avoid this accidental damage, it is advisable to place capacitors between the high- and mid-range power amplifiers and the respective speakers as illustrated. Metallized paper capacitors, metallized mylar capacitors, or oil capacitors are recommended.

Suitable capacitance values can be determined by using the following diagram, where the vertical axis represents crossover frequency (Hz), the horizontal axis represents capacitor value ( $\mu\text{F}$ ), and the slanted lines represent the speaker impedances.

For example, when using a 16 ohm speaker and setting the crossover frequency at 1.2 kHz, the proper capacitor value as shown by the dotted lines is 17  $\mu\text{F}$ .

When the value indicated by the diagram is an odd value, use the nearest standard value. The cutoff frequency is one octave lower than the crossover frequency. Frequencies lower than the cutoff frequency are attenuated at the rate of 6 dB/octave. In the above example the cutoff frequency is 600 Hz.

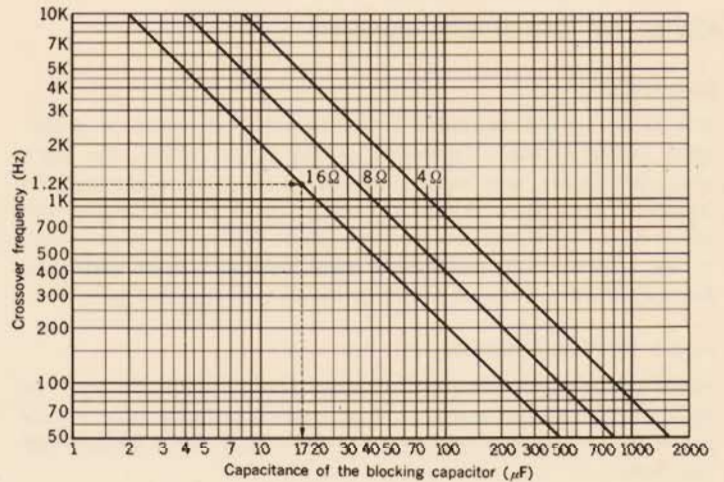

### Use of the FUNCTION Selector

Instantaneous selection of INPUT 1 or 2 is possible with the FUNCTION selector. This feature is convenient for comparing two signal sources or two preamplifiers, or for comparing a multi-channel amplification system and an ordinary full-range system, as shown below.

Note:

When the TA-3200F's FUNCTION selector is set to INPUT 1, you will also have to cut the drive to the channel dividing preamplifier

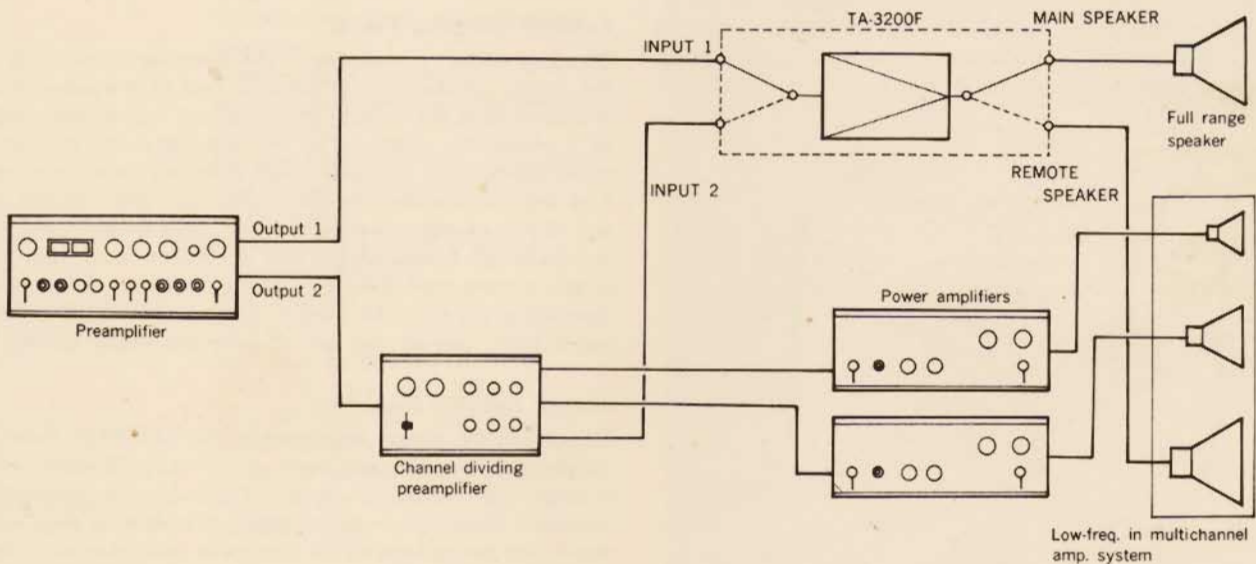



## CARE OF YOUR EQUIPMENT

### CLEANING

The finish on the TA-3200F's front panel and knobs is practically indestructible. However, greasy finger prints, the kid's chocolate candy, and similar household annoyances can mar the beauty of your unit. These can be cleaned up by wiping the panel and knobs with a soft clean cloth moistened with water. If this is ineffective, use a soft cloth saturated with methanol. Do not use any type of scouring powder or abrasive pad.

### FUSE REPLACEMENT

Fuses occasionally blow for no other reason than old age. In case the TA-3200F suddenly goes dead it is likely that a fuse has blown. You can replace the blown fuse with 5 ampere 125 volt fuse.

Simply flip the POWER switch to OFF, then unplug the TA-3200's line cord. Unscrew the fuse-holder cap in a counter-clockwise direction until it and the fuse can be removed. Then, pull out the old fuse, insert a new one in the fuse-holder cap, and screw them back into the fuse holder. After doing this, plug the TA-3200F's line cord into the ac receptacle and flip the POWER switch to ON.

### CAUTION

**If the fuse blows again,  
contact your SONY dealer.**

### REPACKING FOR SHIPMENT

The TA-3200F's original shipping carton and packing material (which we asked you to save) is the ideal container for shipping the unit for repair work, or simply to another location. However, to achieve the maximum protection, the TA-3200F must be repacked in this material precisely as before. The proper repacking procedure is as shown in the illustration.

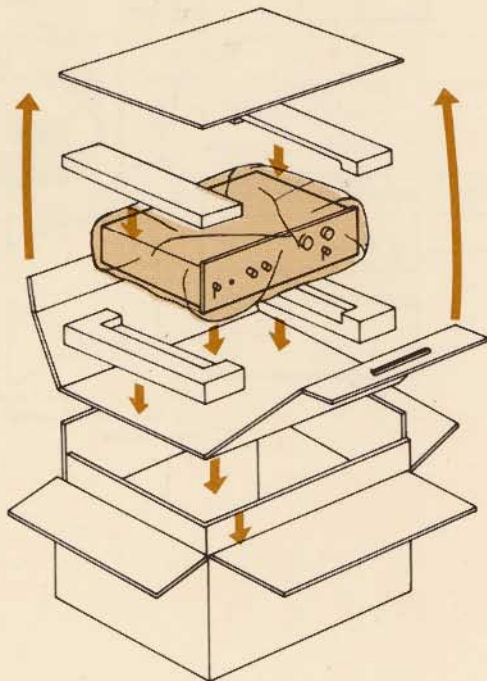

## TECHNICAL DATA

### TECHNICAL DESCRIPTION

#### Direct Output Coupling

Conventionally designed SEPP OTL (Single-Ended Push-Pull Output-Transformerless) amplifiers use a coupling capacitor between the output transistors and speakers. Enormous capacitors are required for good low-frequency response and low power dissipation. Even so, frequency response is poor at very low frequencies and the capacitor must dissipate large amounts of power during high-power operation. This not only wastes power but also shortens the equipment life.

In the TA-3200F, balanced positive and negative power supplies permit direct coupling between speakers and output transistors. This improves the frequency response, provides high power output and full damping factor at low frequencies, and makes the equipment more reliable.

#### Extended Frequency Range

To amplify the audible range of frequencies with the lowest possible distortion, a great amount of negative feedback should be applied. Furthermore, frequency response should remain flat over a frequency range that is several times wider than the audible range.

The TA-3200F uses silicon transistors having high cutoff frequencies to obtain extremely flat frequency response up to 30 kHz without the help of negative feedback. Therefore, when 40 dB of negative feedback is applied to each circuit, the frequency response is flat within +0 dB, -2 dB between 5 Hz-200 kHz.

#### Superior Damping Factor

Damping factor—a measure of the amplifier's ability to control the motion of the speaker cone—is one of the essential factors in determining the quality of the sound reproduced (especially as it affects the clearness of the low-frequency portion of the audio spectrum). To obtain high damping factor and maintain it at low frequencies, the TA-3200F uses direct output coupling and heavy negative feedback. The result is that using the IHF standards of measurement and an 8-ohm load, the damping factor is more than 200 from 20 Hz to 1 kHz, and is still more than 50 at 20 kHz. This value, coupled with very low distortion, yields truly phenomenal sound over the entire audible range.

#### Lowest Possible Distortion

The silicon transistors employed in the TA-3200F have a high cutoff frequency ( $f_T$ ) and high current amplification ratio ( $h_{FE}$ ) through their operating range. There are no transformers to introduce distortion or deterioration of frequency response. As a result, the percentage of IM distortion and harmonic distortion has reached an unprecedented low; it is less than 0.1% at 100 watt output.



## TECHNICAL SPECIFICATIONS

Dynamic power output: (IHF)	320 watts/8 ohms 500 watts/4 ohms
Continuous RMS power output: (Less than 0.1% THD)	At 1 kHz 110+110 watts/8 ohms 130+130 watts/4 ohms Both channels driven simultaneously
	At 20 Hz-20 kHz 100+100 watts/8 ohms Both channels driven simultaneously
Power bandwidth: (IHF)	5 Hz-35 kHz
Harmonic distortion: (20 Hz-20 kHz)	Less than 0.1% at rated output Less than 0.05% at 1 watt output
IM distortion:	Less than 0.1% at rated output Less than 0.03% at 1 watt output
Frequency response:	5 Hz-200 kHz $\begin{matrix} +0 \\ -2 \end{matrix}$ dB (at 1 watt output, NORMAL/TEST switch set at TEST) NORMAL setting cuts low frequencies below 30 Hz by 6 dB/octave.
S/N ratio:	110 dB, short-circuited
Residual noise:	Less than 0.003 $\mu$ watt/8 ohms
Damping factor:	170/8 ohms, at 1 kHz
Inputs:	Sensitivity 1.4 volts (for rated output) Impedance: 75k ohms Two pairs of inputs equipped with level controls.
Outputs:	Accept 4-16 ohm speakers. Equipped with two pairs of speaker outputs.
System:	All silicon-transistor stereo power amplifier Direct output coupling Quasi-complementary symmetry circuit (SEPP OTL) Equipped with transistor protection and speaker protection circuits.
Semiconductors:	31 transistors 41 diodes (including 1 silicon- controlled rectifier)
Power requirements:	117 volts ac
Power consumption:	160 watts
Ac outlets:	Switched 1, Unswitched 1 Total 300 watts
Dimensions:	15 $\frac{3}{4}$ (w) $\times$ 5 $\frac{7}{8}$ (h) $\times$ 12 $\frac{3}{4}$ (d) inches
Weight:	30 lbs 10 ozs (net) 36 lbs 14 ozs (in shipping carton)
Supplied accessories:	Phono plugs (4) Polishing cloth (1)

Design and specifications subject to change without notice.

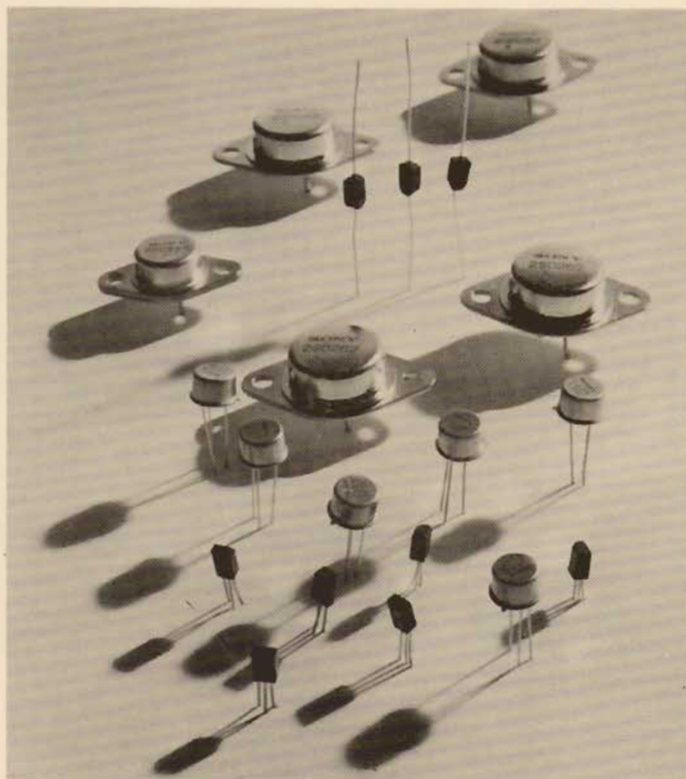

## OPERATING CURVES

### Frequency Response

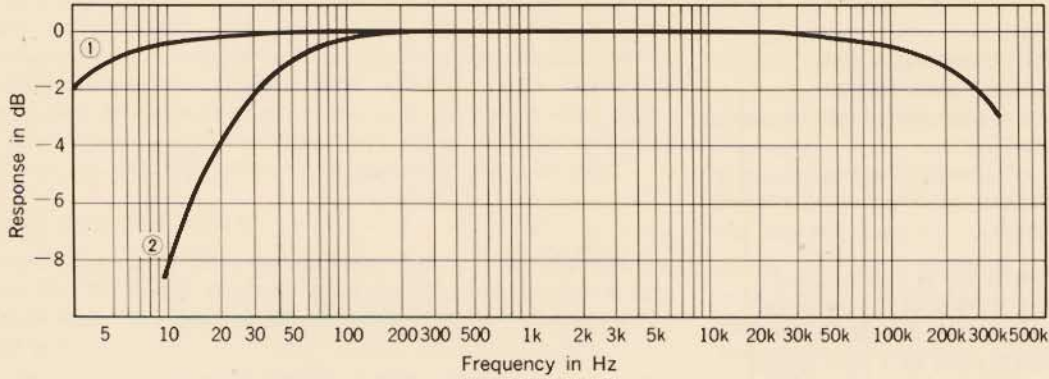

Output: 1 watt (0 dB on graph)  
 Load impedance: 8 ohms  
 LEVEL controls: maximum output  
 NORMAL/TEST switch:  
     curve ① in TEST position  
     curve ② in NORMAL position

### Power Output vs. Harmonic Distortion

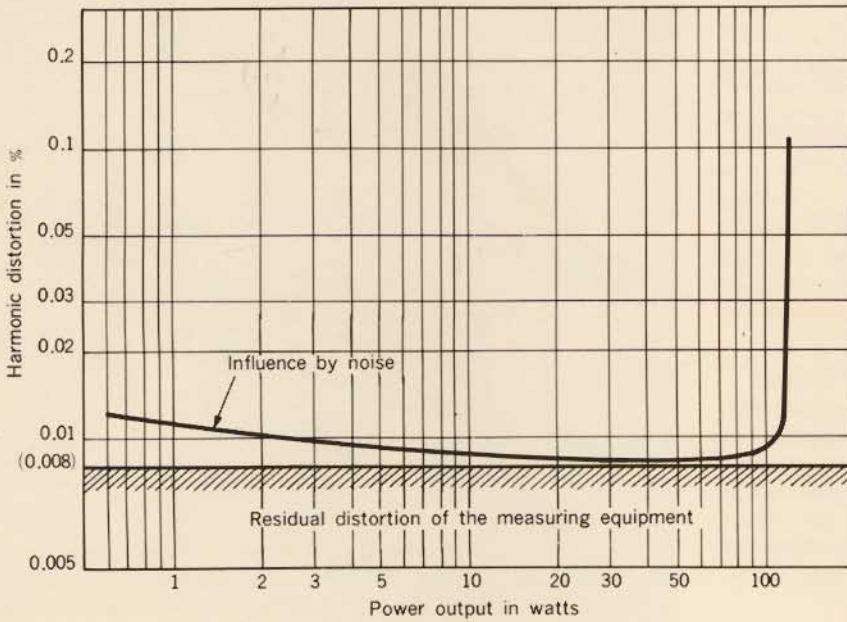

1 kHz input signal  
 Measured with both channels operating  
 Load impedance: 8 ohms  
 LEVEL controls: maximum output  
 NORMAL/TEST switch: TEST position  
 POWER LIMITER switch: FULL position

**Power Output vs. IM Distortion**

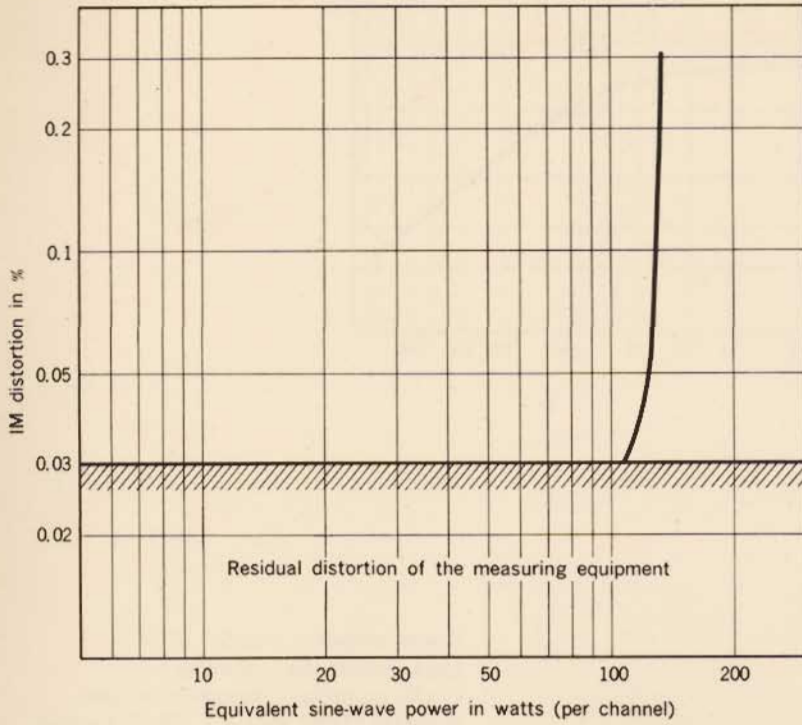

60 Hz and 7 kHz input signals :  
 4 : 1 amplitude ratio  
 Load impedance : 8 ohms  
 NORMAL/TEST switch : TEST position  
 POWER LIMITER switch : FULL position  
 Measured with both channels driven to equal output levels.

**Frequency Response vs. Harmonic Distortion**

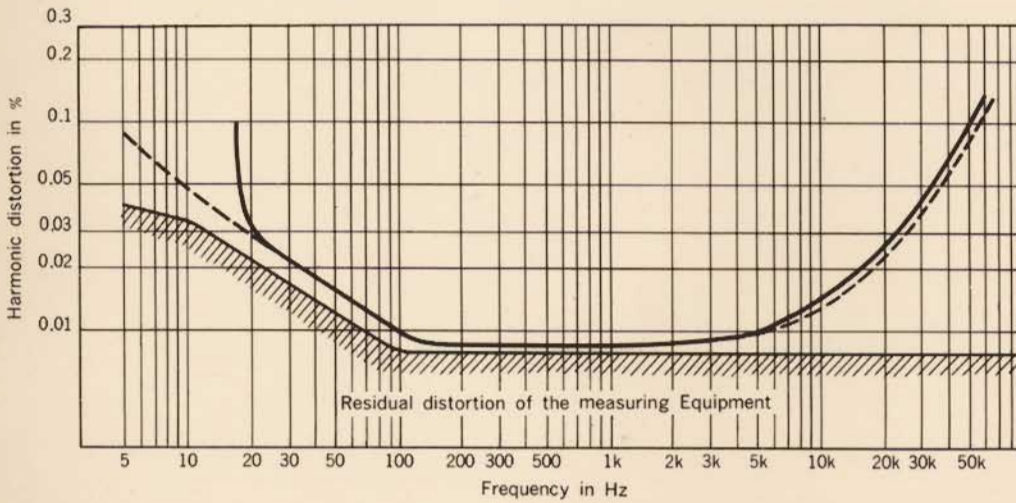

Curve : — output 100 watts constant  
 ..... output 50 watts constant  
 (without speaker protection circuit)  
 Load impedance : 8 ohms  
 Measured with both channels operating  
 LEVEL controls : maximum output  
 NORMAL/TEST switch : TEST position  
 POWER ILMITER : FULL position



### Frequency Response vs. Damping Factor

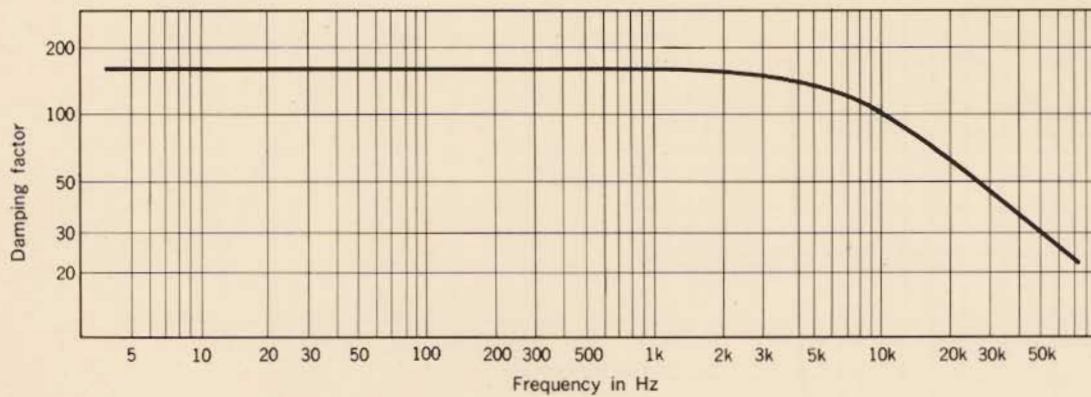

Power output : 1 watt  
Load impedance : 8 ohms  
LEVEL controls : maximum output  
NORMAL/TEST switch : TEST position  
POWER LIMITER switch : at FULL position

