

SPECIFICATIONS

GENERAL

Power Requirements: 120 V ac, 60 Hz (US model)
110, 120, 220 or 240 V ac adjustable,
50 or 60 Hz (UK, AEP model)

Power Consumption: 18 W (US, AEP model)
23 W (UK model)

Dimensions: Approx. 430 (w) x 170 (h) x 320 (d) mm
17 (w) x 6 $\frac{3}{4}$ (h) x 12 $\frac{1}{8}$ (d) inches
including projecting parts and controls

Weight: Approx. 7 kg, 15 lb 7 oz (net)
Approx. 8.2 kg, 18 lb 2 oz (in shipping carton)

TUNER SECTION

Tuning Range: 87.5 – 108 MHz

Antenna Terminals: 300 Ω , balanced
75 Ω , unbalanced coaxial input

Intermediate Frequency: 10.7 MHz

Sensitivity at 50 dB Quieting: 3.4 μ V, new IHF 15.9 dBf (mono) } (US model)
39 μ V, new IHF 37.1 dBf (stereo) }

Sensitivity at 46 dB Quieting: 3.4 μ V, new IHF 15.9 dBf (mono) } (UK, AEP model)
(40 kHz dev.) 39 μ V, new IHF 37.1 dBf (stereo) }

Usable Sensitivity: IHF 1.5 μ V, S/N: 26 dB (40 kHz dev.)
new IHF 8.8 dBf
(UK, AEP model)
IHF 1.7 μ V, new IHF 9.8 dBf

Frequency Response: 40 Hz–12.5 kHz $\begin{matrix} +0.3 \\ -0.8 \end{matrix}$ dB (UK, AEP model)
30 Hz – 15 kHz $\begin{matrix} +0.2 \\ -1.5 \end{matrix}$ dB

Selectivity:

| | NORMAL | NARROW |
|---------|--------|--------|
| 200 kHz | — | — |
| 300 kHz | — | 65 dB |
| 400 kHz | 55 dB | 85 dB |

Capture Ratio: 1.0 dB (NORMAL), 1.2 dB (NARROW)

AM Suppression Ratio: 60 dB

Image Response Ratio: 120 dB

IF Response Ratio: 120 dB

Spurious Response Ratio: 120 dB

RF Intermodulation: 80 dB

Sub-carrier Product Ratio: 70 dB

Muting Threshold: Approx. 5 μ V

Output Level: FIXED 750 mV, 4 k Ω
(75 kHz dev.)
VARIABLE 0 to 1.2 V, 0.2 k Ω at max. position

CAL TONE: 50% modulation (37.5 kHz dev.),
400 Hz

Limiting Threshold: 1.0 μ V, new IHF 5.4 dBf
(UK, AEP model)

S/N Ratio: 79 dB (mono) } (US model)
(40 kHz dev.) 74 dB (stereo) }
74 dB (mono) } (UK, AEP model)
69 dB (stereo) }

Harmonic Distortion: (40 kHz dev.)

| | mono | | stereo | |
|--------|--------|--------|--------|--------|
| | NORMAL | NARROW | NORMAL | NARROW |
| 100 Hz | 0.08% | 0.2% | 0.15% | 0.4% |
| 1 kHz | 0.08% | 0.2% | 0.15% | 0.4% |
| 10 kHz | 0.08% | 0.2% | 0.3% | 0.6% |

IM Distortion:
(40 kHz dev.)

| | mono | | stereo | |
|--|--------|--------|--------|--------|
| | NORMAL | NARROW | NORMAL | NARROW |
| | 0.08% | 0.2% | 0.15% | 0.4% |

Separation:

| | NORMAL | NARROW |
|--------|--------|--------|
| 100 Hz | 43 dB | 40 dB |
| 1 kHz | 45 dB | 40 dB |
| 10 kHz | 40 dB | 35 dB |



SONY

SERVICE MANUAL

MODEL IDENTIFICATIONS

— Specification Label —

• US model

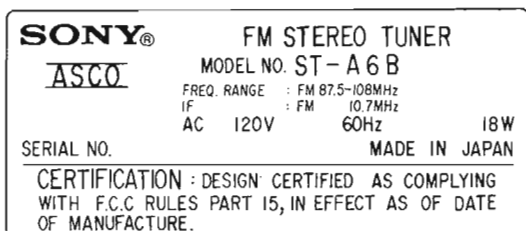

• AEP model

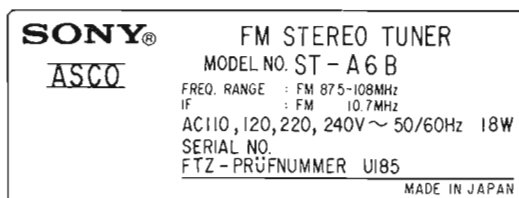

• UK model

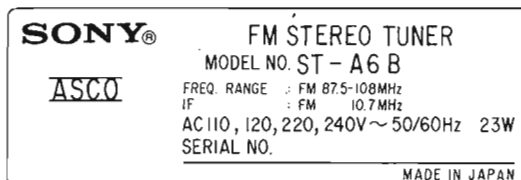

1-1. CIRCUIT DESCRIPTION

OUTLINE

The ST-A6B FM tuner has been designed to satisfy the demands of the more discriminating FM listeners. The major circuits are outlined below.

1. Front-End Section

Refer to Fig. 1-2 for the block diagram of the front-end. The input signals from the antenna are applied to a double-tuning circuit (L101, CV101, L102, and CV102) where the unwanted frequencies are effectively removed. See Fig. 1-1 for the band-pass characteristics curve.

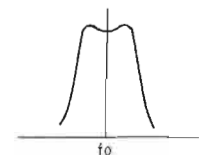

Fig. 1-1

Signals which pass through the double-tuning circuit are amplified by the RF-stage dual-gate MOS FET (Q101) having high-gain and low-noise RF amplification performance with low crossmodulation distortion in VHF band.

The signals amplified by Q101 are then fed to the 2-stage double-tuning circuit where only those signals very close to the center frequency (f_0) are passed to the FM mixer (Q102). This mixer uses a dual MOS FET having a remote cut-off characteristic to reduce RF crossmodulation distortion*.

When the input signal is then applied to the 2nd gate of Q102, and the local oscillator signal to the 1st gate, an IF signal is obtained in the 10.7 MHz resonator circuit which is the load of the drain circuit. This IF signal is then applied to the IF amplifier stage (Q103).

Even in high grade front-ends, the local oscillator circuit is important. In the ST-A6B, the local oscillator is integrated together with the tuning capacitor for greater operational stability and excellent frequency-accuracy. A buffer amplifier is also inserted into this circuit to prevent the local oscillator from having undesirable effect by the mixer, and thereby ensuring high quality reception even with large input signals. In addition, the ST-A6B is provided with a 7-ganged tuning capacitor which results in an extremely good image rejection.

* RF crossmodulation distortion: if there are two strong broadcasting waves received in close proximity to each other, for example, at 93.8 MHz and 94.6 MHz, a carrier at 93.0 MHz ($93.8 \text{ MHz} \times 2 - 94.6 \text{ MHz}$) will be modulated by undesired strong signal. And this will result in distortion if the desired station is at 93.0 MHz.

2. IF Amplifier and Detector Stages (see Fig. 1-3)

The IF signal from the front-end passes through CF201 (solid-state filter), is amplified by the FM IF amplifier stage (Q201–Q204), and then applied to the automatic IF bandwidth selector circuit (described later). This circuit decides whether the input signal should be passed through a second solid-state filter stage (CF202 and CF203) or not, according to the strength of the signal. The signal, which passes through CF202 and CF203 or does not pass through them, is then applied to a 5-stage differential amplifier (IC201) where the signal amplitude is sufficiently limited. The signal is then applied to the ratio detector circuit, demodulated, and converted into an AF signal (or composite stereo signal).

3. Stereo Decoder and AF Amplifier Stages (See Fig. 1-4)

The ST-A6B is equipped with a PLL IC (IC301) to obtain the AF signal (stereo) from the composite stereo signal. Since the stereo decoding (demodulation) in this type utilizes a switching signal locked to a pilot signal included in the composite stereo signal, this decoder assures high stability and reliability. The AF signals separated into left and right channels by IC301 appear at terminals ④ and ⑤, and passes through buffer amplifier Q303/Q302 and then through low-pass filters LPF501 and LPF551 where any remaining unwanted signal components are removed. Following a final amplification in the Q501/Q502 (Q551/Q552) AF amplifier, the output signals are then fed to the FIXED and VARIABLE output terminals.

4. Muting Circuit and CAL TONE

Muting of unwanted switching noises etc. is achieved via reed relays inserted in the output circuit. In addition, the ST-A6B also incorporates an oscillator circuit (Q701) used for recording level calibration purposes. When the SELECTOR switch is set to the CAL TONE position, a 400 Hz sine wave signal appears at the output terminals.

ST-A6B

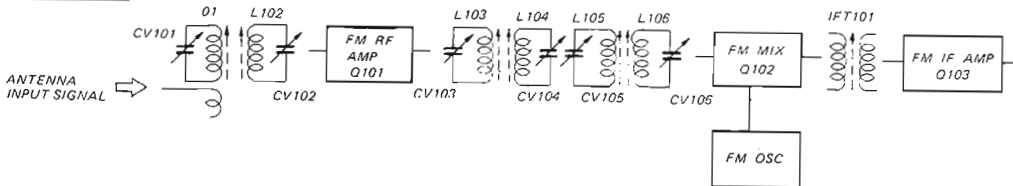

Fig. 1-2

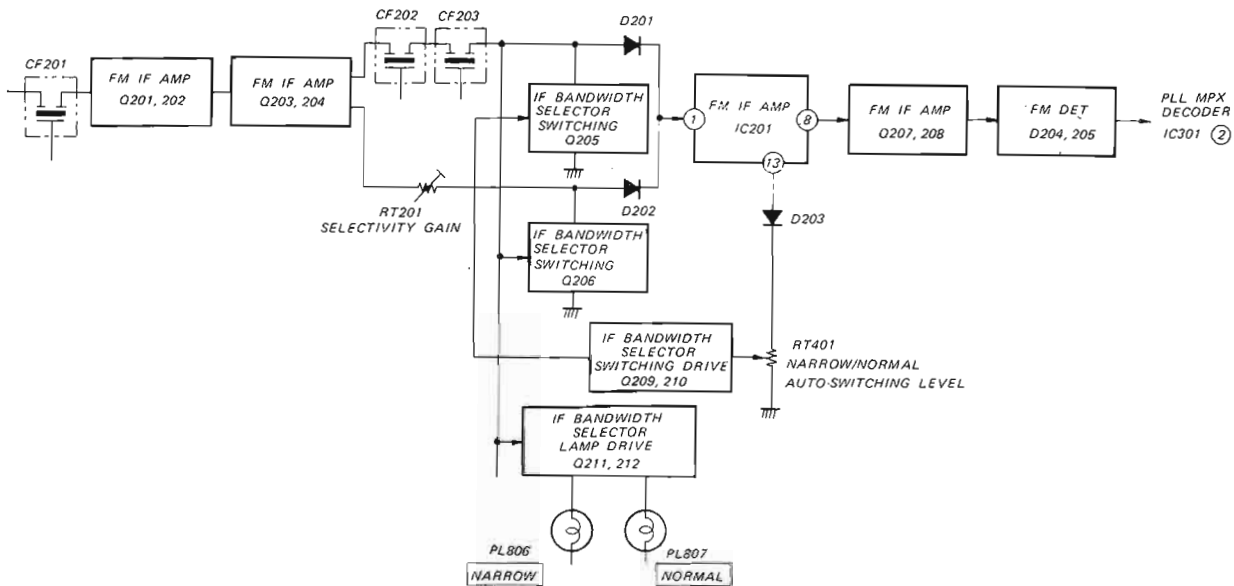

Fig. 1-3

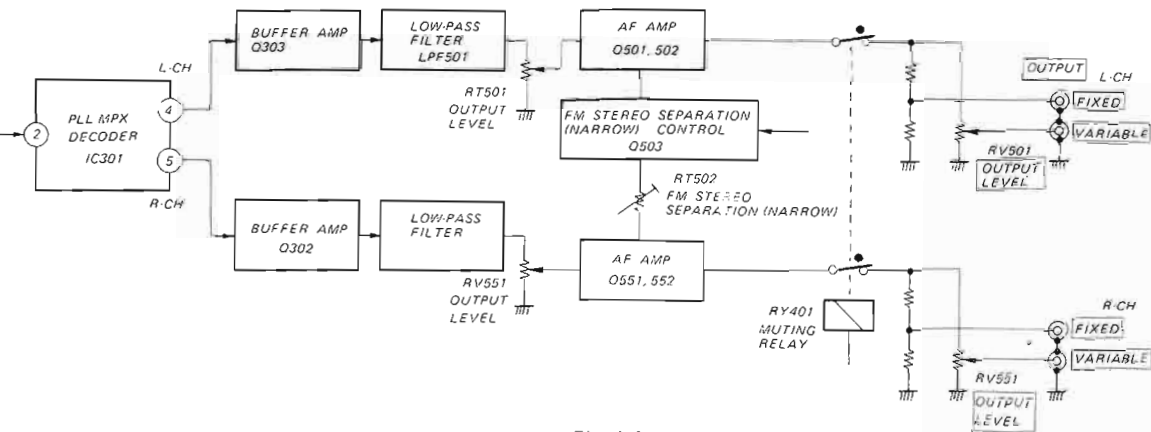

Fig. 1-4

The automatic IF bandwidth selector and muting circuits are described below in a little more detail.

Automatic IF Bandwidth Selector Circuit

The increase in the number of FM stations has presented a problem in the form of adjacent channel interference. This interference can be eliminated by employing a much narrower band width in the IF amplifier stage, but only by sacrificing the quality of sound. That is, narrow IF band width causes increase in distortion and loss of stereo separation.

For this reason, a switching between narrow and wide bandwidth has been used. While the wide bandwidth (normal) permits good quality reception (low distortion, high stereo separation), the narrow bandwidth (narrow) permits good reception of weaker broadcasts by avoiding interference of adjacent stations.

The band selector switch in the ST-A6B has two positions AUTO and NARROW. In the AUTO position, the selector circuit will switch over automatically to the normal side for broadcasting station whose strength exceeds a certain practical level, but to the narrow side for the station whose strength is below that level. When switched over to normal, relatively strong broadcasts are reproduced with very little distortion and high stereo separation. In the narrow position, relatively weak stations are

received free of interference from adjacent stations. Consequently, the selector switch is left in the narrow position during tuning, and switched over to the normal side if the strength of the tuned station is above a level around 30 dB μ /m.

In the NARROW position, a selectivity as high as 80 dB is employed to eliminate any adjacent channel interference.

The switching operation is described as follows:

1) When receiving a weak or no signal (see Fig. 1-5)

No meter-drive voltage will appear at terminal ⑬ of IC201. Consequently, there will be no voltage applied to the base of Q209, which will therefore turn OFF, and result in Q210 turning ON. Since no voltage will be applied to the base of Q205, this transistor will also turn OFF, resulting in diode D201 being biased in the forward direction. The signal is therefore applied to IC201 via CF202 and CF203 (narrow) (see routes ① to ③).

Q206 will turn ON due to the voltage applied to its base, thereby turning D202 OFF by cutting OFF the forward bias. The normal side signal will

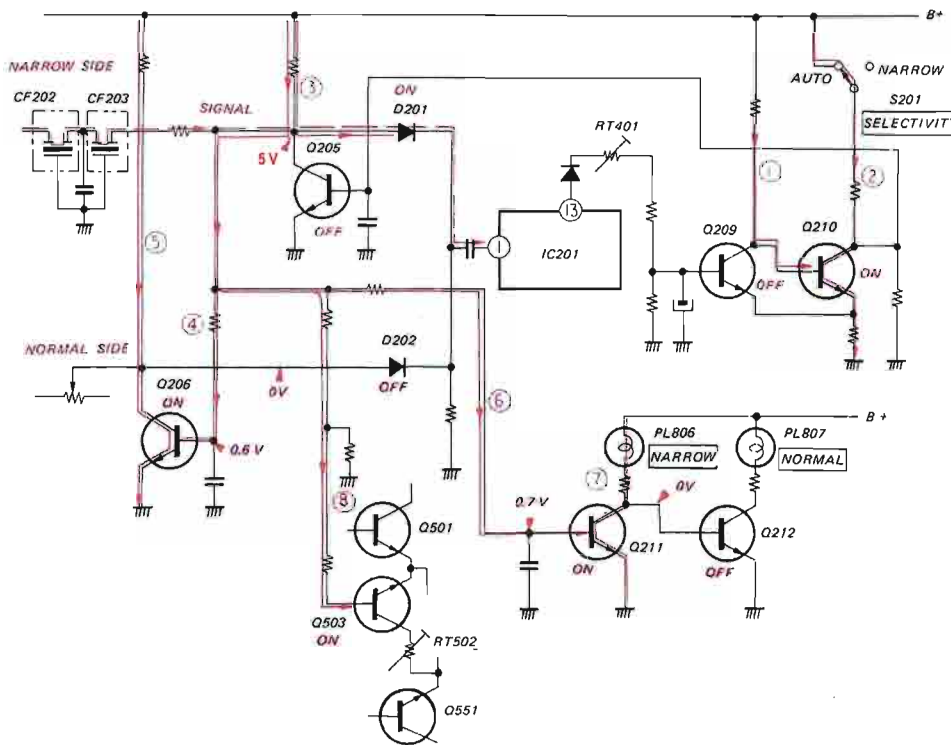
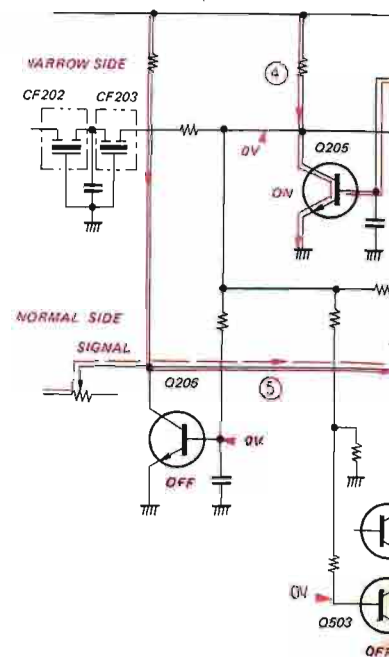

Fig. 1-5



therefore be shunted by Q206, and obstructed by D202 which is kept OFF (see routes ④ and ⑤). Q211 will also turn ON because of the voltage applied to its base, resulting in the NARROW indicator lamp PL806 turning ON (see routes ⑥ and ⑦). Q503 turns ON for the same reason, thereby connecting the emitters of Q501 and Q551, permitting optimum stereo separation to be adjusted by RT502 (see route ⑧).

2) When receiving a strong signal (antenna input level in excess of 30 dB μ). see Fig. 1-6.

A meter-drive voltage will appear at terminal ⑬ of IC201, resulting in turning Q209 ON due to the voltage applied to its base. Q210 will then turn OFF, and Q205 turns ON due to the voltage applied to its base, while D201 remains OFF since no forward biasing is applied. Consequently, the narrow side signal will be shunted out by Q205, and obstructed by D201 (see routes ① to ④).

At the same time, Q206 will turn OFF due to no voltage applied to its base, but D202 will turn ON by the forward biasing. Therefore, the normal side signal will be applied to IC201 (see route ⑤). Furthermore, since there is no voltage applied to the base of

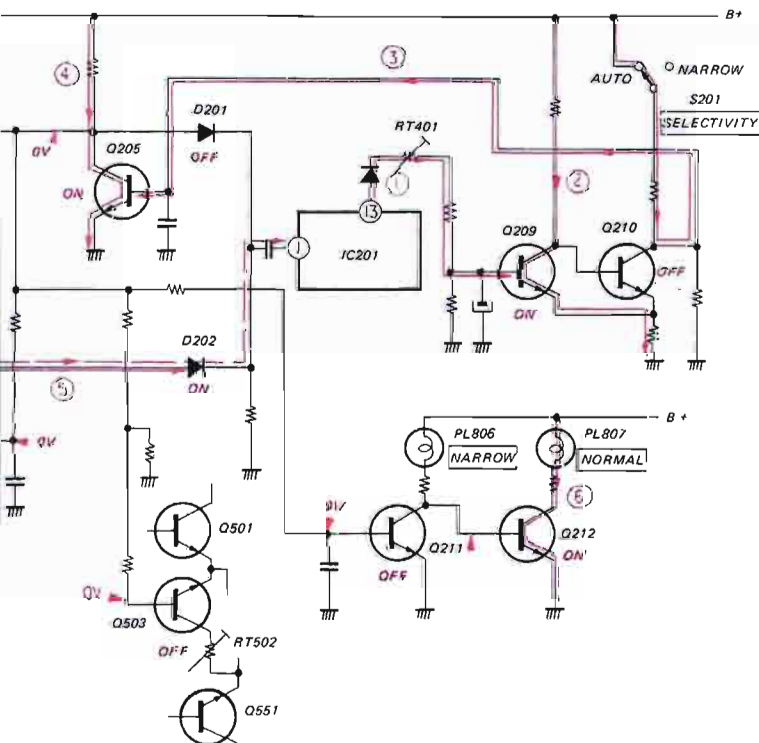

Fig. 1-6

Q211, this transistor will turn OFF, while Q212 turns ON, and the NORMAL indicator lamp PL807 subsequently turns ON (see route ⑥).

And since there is also no voltage applied to the base of Q503, this transistor will turn OFF, thereby disconnecting the Q501 and Q551 emitters to ensure optimum stereo separation during normal.

Muting Circuits

1) When receiving no signal (MUTING switch ON) (see Fig. 1-7 and Fig. 1-8)

With no voltage appearing at terminal ⑬ of IC201, Q404 will turn OFF. But a voltage will appear at terminal ⑫, and this will combine with the Q404 collector voltage (see Fig. 1-8) to be applied to the base of Q402. Q402 will thus turn ON, and Q403 will turn OFF, thereby stopping the muting relay current. This relay will therefore energized to cut off the output of any signals (see routes ① to ④).

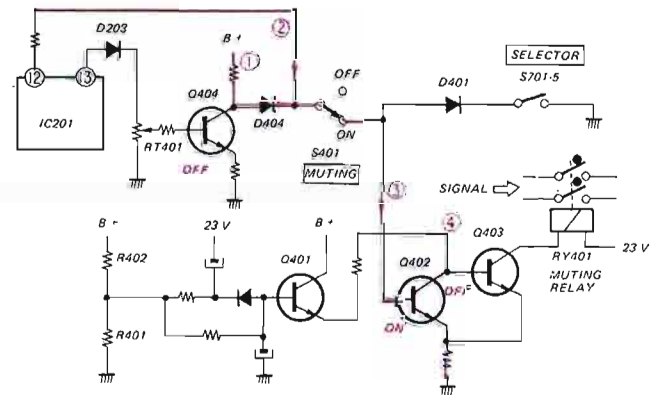

Fig. 1-7

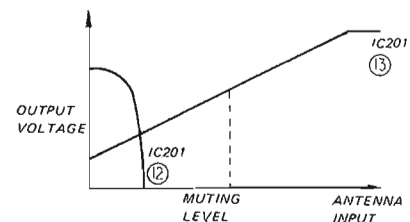

Fig. 1-8

2) When a signal whose level exceeds the muting level is applied to the antenna terminals (see Fig. 1-8 and Fig. 1-9)

Since a voltage will appear at terminal ⑬ of IC201, Q404 will turn ON. But there will be no voltage appearing at terminal ⑫ of this IC (see Fig. 1-8). Therefore, Q402 will turn OFF (with no voltage applied to its base), and Q403 will turn ON, resulting in a current flowing through the muting relay. This relay will thus energized and the audio signal will be applied to the output terminals (see routes ① to ③).

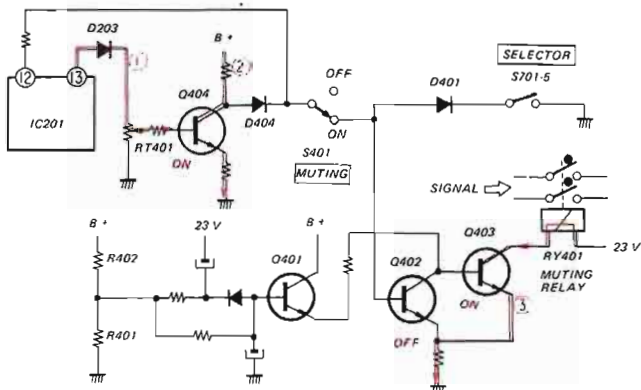

Fig. 1-9

3) When the SELECTOR switch is switched over to the CAL TONE position (see Fig. 1-9 and Fig. 1-10)

The cathode of D401 will be grounded via S701-5, thereby turning Q402 and Q403 OFF, and the muting relay is energized, resulting in the CAL TONE signal (400 Hz) being applied to the output terminals.

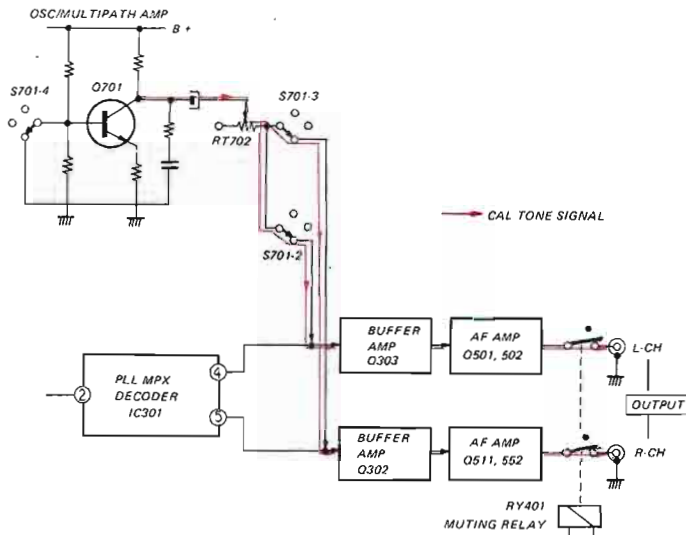

Fig. 1-10

4) Muting at POWER switch ON/OFF (see Fig. 1-11)

*When POWER switch is turned ON

Q401 will remain OFF while C401 is being charged up (approx. 2 seconds, the R408/C401 time constant). Q403 will also remain OFF, the muting relay is de-energized, thereby cutting off the output of any signals. This muting continues during the main circuit warms up, thereby eliminating the unwanted noise in initial starting up.

*When POWER switch is turned OFF

The positive-side voltage of C402 decreases rapidly, resulting in discharging C402 via D402. The Q401 base voltage will thus be reduced, the transistor turning OFF when the voltage decreases below 0.6 V. Q403 will then turn OFF also, resulting in de-energizing the muting relay. Switching noise at this time is thereby completely muted.

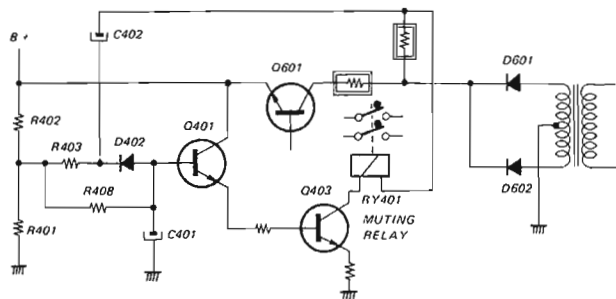

Fig. 1-11

5) Muting at detuning a station (see Fig. 1-7)

This muting is related with the voltage on terminal ⑫ of IC201. When detuning a station, this voltage changes as shown in Fig. 1-12. Once outside the muting range, the voltage on terminal ⑫ is applied to the base of Q402, thereby turning Q402 ON, and turning Q403 OFF. The muting relay is also energized, resulting in the muting of the output sound.

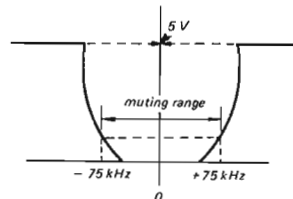

Fig. 1-12

ELECTRICAL ADJUSTMENTS

FM stereo signal

Carrier frequency: 98 MHz
 Deviation: main channel 400 Hz,
 33.75 kHz deviation (45%)
 sub-channel 38 kHz,
 33.75 kHz deviation (45%)
 pilot 19 kHz,
 7.5 kHz deviation (10%)

FM monaural signal

Carrier frequency: 98 MHz
 Modulation: 400 Hz, 75 kHz deviation (100%)

CAUTION

The ceramic filters (CF201, 202, 203 in the FM IF circuit are selected according to their specified center frequencies and color-coded as shown. Check the color code of the filters to identify the same center frequency when replacing any of these filter.

FM IF Ceramic Filters

color code

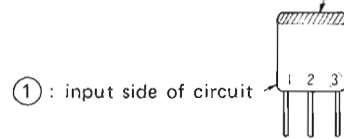

| Color | Specified Center Frequency |
|--------|----------------------------|
| black | 10.64 MHz |
| blue | 10.67 MHz |
| red | 10.70 MHz |
| orange | 10.73 MHz |
| white | 10.76 MHz |

Note: If the color code of new ceramic filter is different from that of used one, be sure to adjust the secondary side core (IFT202 blue) of discriminator transformer.

DISCRIMINATOR TRANSFORMER ADJUSTMENT

Setup:

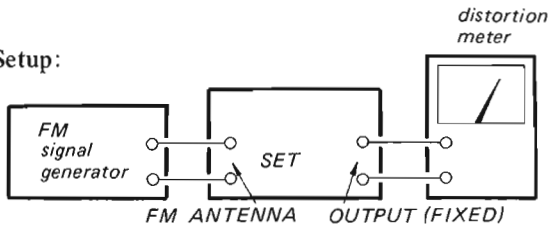

FM Signal Generator Setting:

Carrier frequency: 98 MHz
 Modulation: 400 Hz, 75 kHz deviation (100%)
 Output level: 1 mV (60 dB)

Procedure:

1. Primary-Side

- 1) Set the MODE switch to MONO.
- 2) Set the SELECTIVITY switch to AUTO.
- 3) Tune the set to 98 MHz and adjust the primary-side core (white) of IFT201 for minimum reading on the distortion meter.

2. Secondary-Side

- 1) Set the SELECTIVITY switch to NARROW.
- 2) Detune the set.
- 3) Adjust the secondary-side core (blue) of IFT202 for zero center on the TUNING meter.

3. Repeat the above steps 1 and 2 several times.

IFT201 (primary: white)

IFT202 (secondary: blue)

— tuner/power supply board —

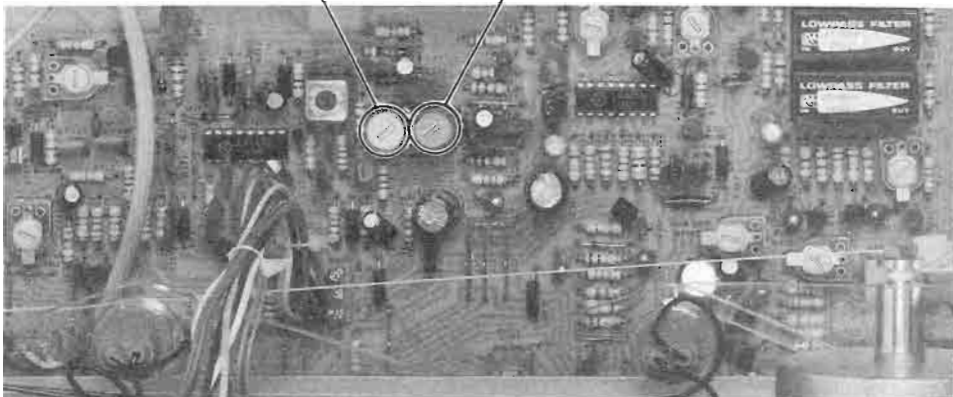

19 kHz ADJUSTMENT

A) With Frequency Counter

Setup:

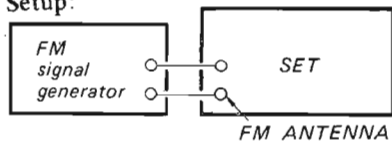

FM Signal Generator Setting:

- Carrier frequency: 98 MHz
- Modulation: no modulation
- Output level: 1 mV (60 dB)

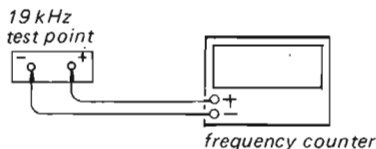

Procedure:

1. Tune the set to 98 MHz.
2. Adjust RT301 for 19 kHz \pm 100 Hz on the frequency counter.

B) Without Frequency Counter

Procedure:

1. Tune the set to the FM stereo broadcasting signal.
2. Turn RT301 clockwise or counterclockwise and note the lighting-up range of STEREO lamp.
3. Secure RT301 at the center in lighting-up range of both turns as shown below.

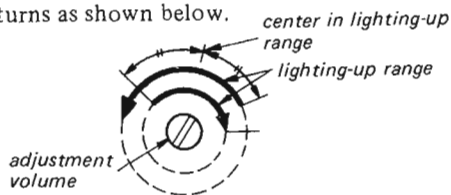

GAIN ADJUSTMENT FOR SELECTIVITY CHANGE

Setup:

- MODE switch: MONO
- SELECTIVITY switch: NARROW

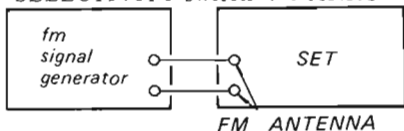

FM Signal Generator Setting:

- Carrier frequency: 98 MHz
- Modulation: no modulation
- Output level: 100 μ V (40 dB)

Procedure:

1. Tune the set to 98 MHz.
2. Note the LEVEL meter reading.
3. Set the SELECTIVITY switch to AUTO.
4. Adjust RT201 for the same LEVEL meter reading as in step 2.

– tuner/power supply board –

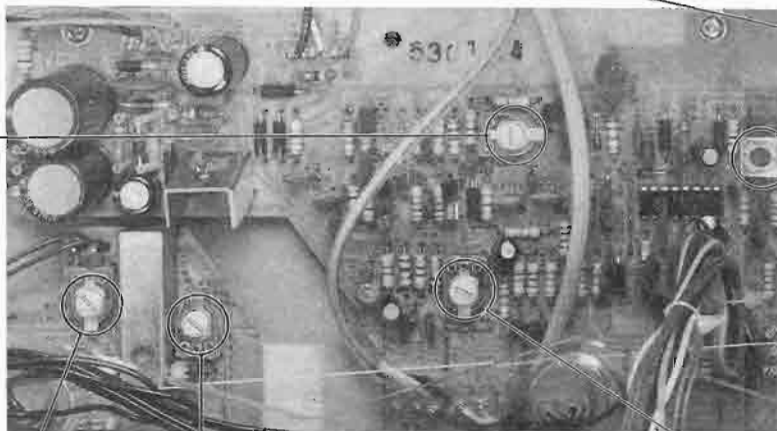

RT201

RT702

RT701

RT301

CAL TONE ADJUSTMENT

Setup:

- SELECTOR switch: CAL TONE
- VTVM

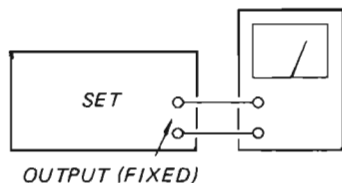

Procedure:

Adjust RT702 for -6 dB (0.39 V) on the VTVM.

Note: Oscillation Frequency: 400 Hz

METER LEVEL ADJUSTMENT

Setup :

- SELECTIVITY switch: NARROW



FM Signal Generator Setting:

- Carrier frequency: 98 MHz
- Modulation: no modulation
- Output level: 3.16 mV (70 dB)

Procedure:

Tune the set to 98 MHz and adjust RT701 for the pointer deflection of '4.8' on the LEVEL meter.

FM STEREO SEPARATION ADJUSTMENT

Setup:

MODE switch: STEREO
SELECTIVITY switch: AUTO

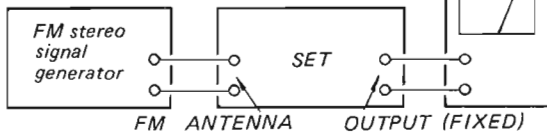

FM Stereo Signal Generator Setting:

Carrier frequency: 98 MHz
Output level: 1 mV (60 dB)
Mode: Stereo
Audio (400 Hz) Mod: 33.75 kHz (45 %)
Pilot (19 kHz) Mod: 7.5 kHz (10 %)

Procedure:

| FM stereo signal generator modulated channel | VTVM connection | VTVM reading |
|--|-----------------|--|
| L-CH | L-CH | (A) |
| R-CH | L-CH | (B) Adjust RT302 for minimum reading. |
| R-CH | R-CH | (C) |
| L-CH | R-CH | (D) Adjust RT302 for minimum reading. |

1. Difference between (A)-(B) and (C)-(D) should be less than 2 dB. If not, readjust RT302.
2. Set the SELECTIVITY switch to NARROW.
3. Adjust RT502 so that both separations (A)-(B) and (C)-(D) are in the same value and maximum.

TEST POINT

RT302

RT502

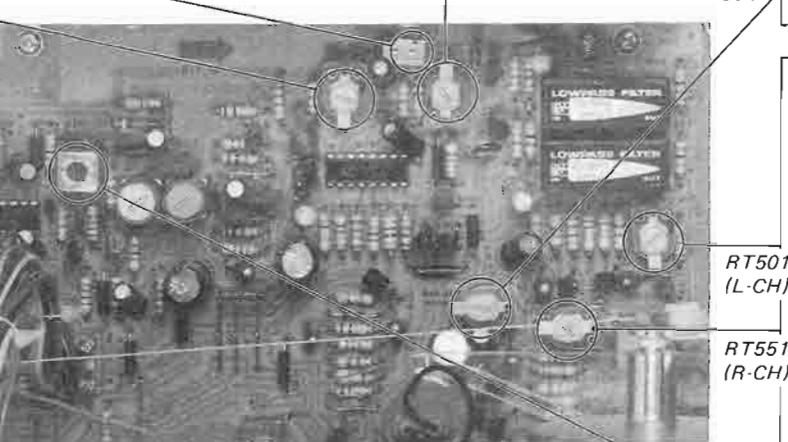

OUTPUT LEVEL ADJUSTMENT

Setup:

SELECTIVITY switch: AUTO

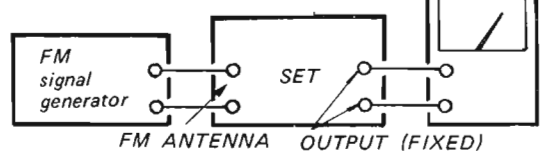

FM Signal Generator Setting:

Carrier frequency: 98 MHz
Modulation: 400 Hz, 75 kHz deviation (100 %)
Output level: 1 mV (60 dB)

Procedure:

Adjust RT501 (L-CH) and RT551 (R-CH) for 0.775 V (0 dB) reading on the VTVM.

RT401

T201 (RED)

NARROW/NORMAL AUTO-SWITCHING LEVEL ADJUSTMENT

Setup:

MODE switch: MONO
SELECTIVITY switch: AUTO

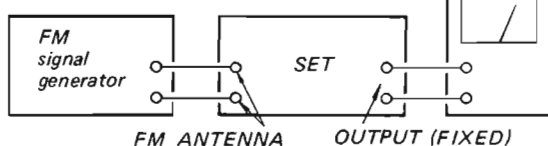

FM Signal Generator Setting:

Carrier frequency: 98 MHz
Modulation: 400 Hz, 75 kHz deviation (100 %)
Output level: 100 μ V (40 dB)

Procedure:

1. Tune the set to 98 MHz.
2. Adjust RT401 so that the lamp indication is changed from NORMAL to NARROW at the moment when the output of FM signal generator is changed to 30 dB (31.6 μ V).

MUTING RANGE ADJUSTMENT

Setup:

MODE switch: MONO
SELECTIVITY switch: AUTO
MUTING switch: ON

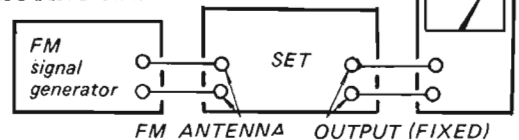

FM Signal Generator Setting:

Carrier frequency: 98 MHz
Modulation: 400 Hz, 75 kHz deviation (100 %)
Output level: 1 mV (60 dB)

Procedure:

1. Tune the set to 98 MHz.
2. When the TUNING knob is turned counterclockwise and clockwise to detune the set from the signal, adjust T201 (RED) for 0 V reading on the VTVM at the same deflection on the TUNING meter.

SECTION 4 DIAGRAMS

4-1. MOUNTING DIAGRAMS —FM Front-End Board—

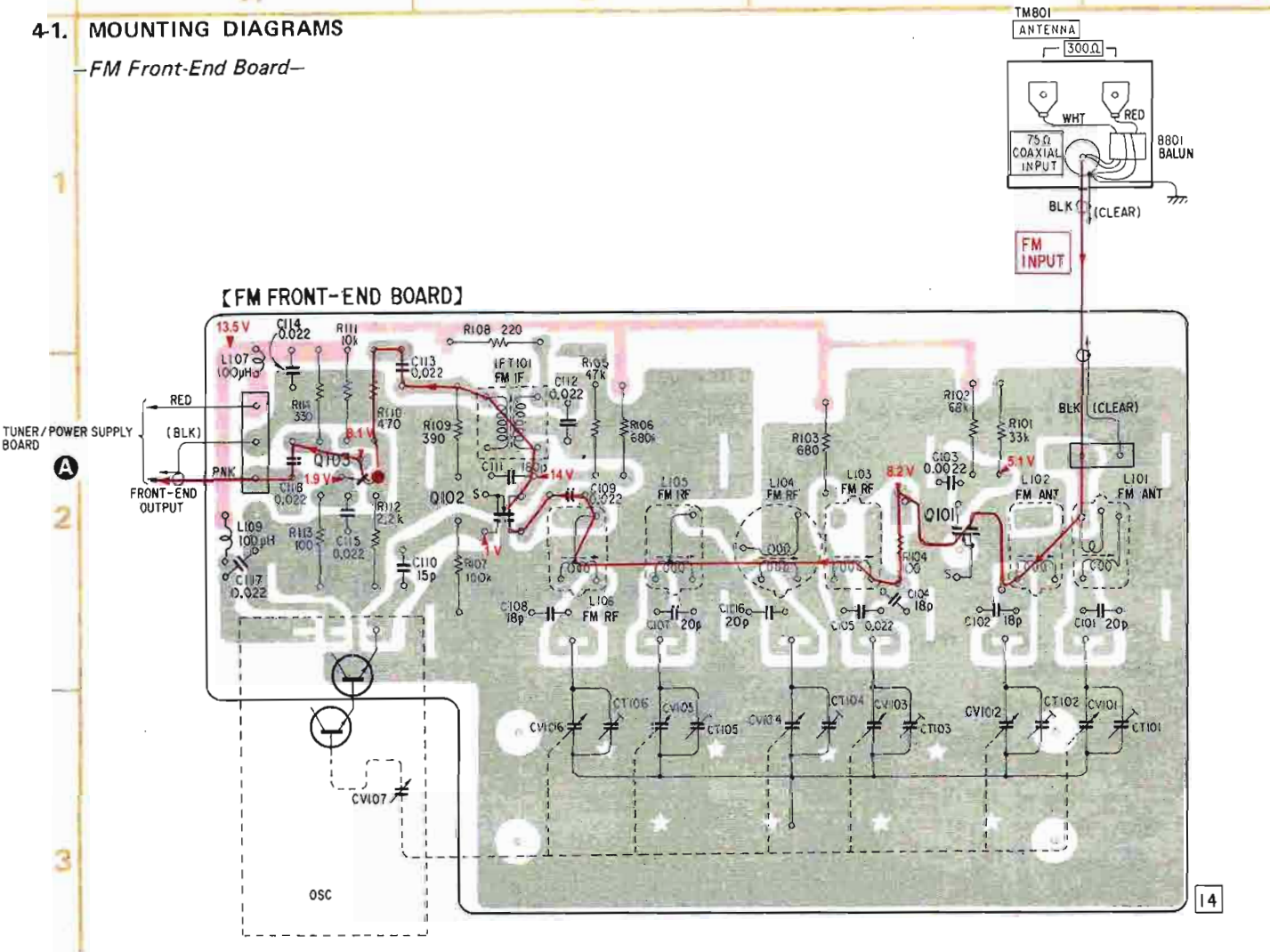

- Color code of sleeving over the end of the jacket.

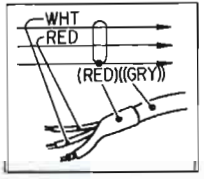

- : parts extracted from the component side.
- : FM signal path.
- : B+ pattern.
- Voltages are dc with respect to ground unless otherwise noted.
- Readings are taken under no-signal conditions with a VOM (20 kΩ/V).
- Voltage variations may be noted due to normal production tolerances.

4-2. MOUNTING DIAGRAMS

— Tuner/Power Supply, Switch, OSC/Multipath Amp Board —

Replacement Semiconductors.

For replacement, use semiconductors except in ().

Q101: 3SK37
Q102: 3SK64

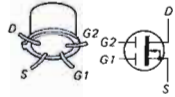

Q103, 208: 2SC1364
Q205, 206
Q209-213
Q301-303
Q401-404
Q501-503
Q551, 552

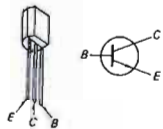

Q201-204, 2SC403C (2SC403)
Q207
Q701: 2SC1636

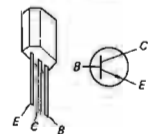

Q601: 2SC1061

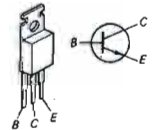

IC201: LA1230
IC301: LA3350

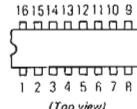

D201-203
D401-404
D701-703
D204-207: 1T22AM (1T22A)
D601, 602: 10E2

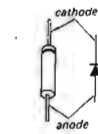

D603: EQB01-16 (EQA01-16R)

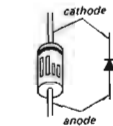

- Color code of sleeving over the end of the jacket.

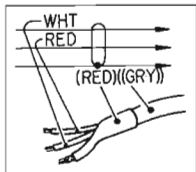

- ○ : parts extracted from the component side.
- : B + pattern
- Signal Path
 - : FM
 - : L-CH audio
 - : R-CH audio
- Voltages are dc with respect to ground unless otherwise noted.
- Readings are taken under no-signal conditions with a VOM (20 kΩ/V).
- no mark : S201 (SELECTIVITY) NARROW
S401 (MUTING) OFF
S501 (MODE) STEREO
S701 (SELECTOR) SIGNAL
- [] : S701 (SELECTOR) CAL TONE
- { } : S401 (MUTING) ON
- < > : FM STEREO

- Voltage variations may be noted due to normal production tolerances.

[TUNER/POWER SUPPLY BOARD]

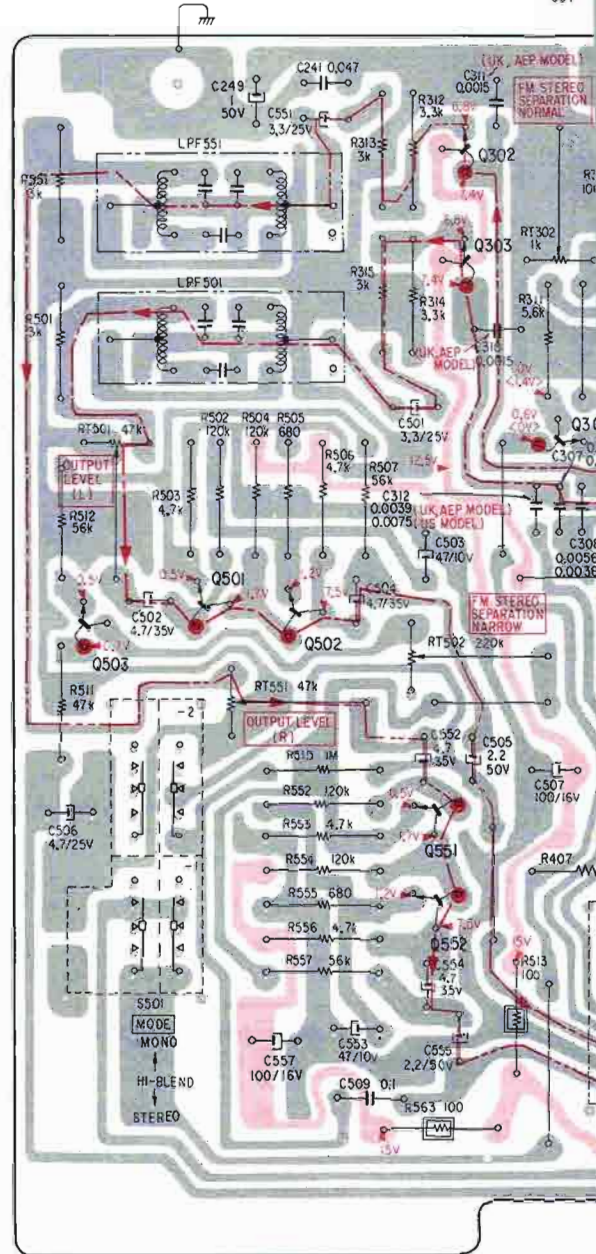

| | | | | | |
|----|-----|-----|-----|-----|-----|
| Q | | | | 551 | 302 |
| IC | 503 | 501 | 502 | 552 | 303 |
| D | | | | | 301 |

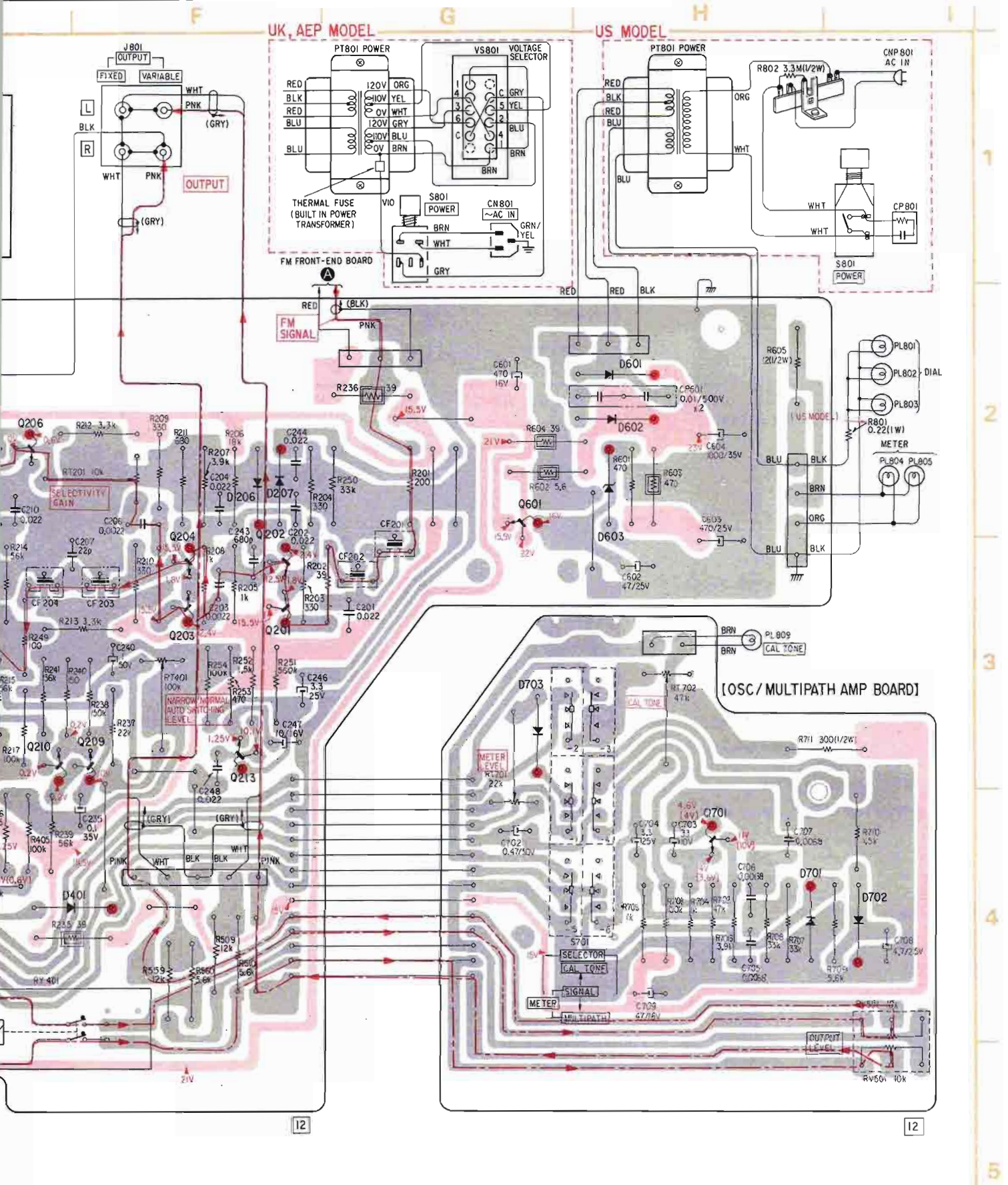

| | | | | | | | | | | | | |
|-----|-----|-----|-----|-----|-----|-----|-----|-----|-----|-----|-----|----|
| 206 | 210 | 209 | 204 | 203 | 202 | 201 | 213 | 206 | 207 | 601 | 701 | Q |
| 401 | | | | | | | | | | 703 | 601 | IC |
| | | | | | | | | | | | 602 | D |
| | | | | | | | | | | | 603 | |
| | | | | | | | | | | | 701 | |
| | | | | | | | | | | | 702 | |

4-2. SCHEMATIC DIAGRAM

