

NATIONAL
Sears
TRAINING

division 61

LXI Stereo

SOURCE 564

SERVICE TRAINING 80-61S-1B



DEPT. 707-1 CHICAGO
PRINTED IN THE U.S.A. 8-80

TABLE of CONTENTS

Page 1	Technical Specifications
3	Operating the Receiver
5	Radio Operation
6	SECTION I — Block Diagram
7	SECTION II — Gating
10	SECTION III — Tuner Board
15	SECTION IV — Phase-Locked Loop
16	SECTION V — Synthesizer Logic, Memory Scan, & LED Display Boards
20	SECTION VI — Function Switch & Indicator Boards
21	SECTION VII — Audio Switch, Pre-amp & Equalizer Boards
22	SECTION VIII — Amp/Power Supply Board
25	Schematics & Printed Circuit Board Layouts
57	Alignment Procedures
60	Troubleshooting Charts

TECHNICAL SPECIFICATIONS

FM TUNER SECTION

Usable Sensitivity for 30 dB IHFM	Mono	2.2 μ V
	Stereo	6.5 μ V
50dB Quieting Sensitivity	Mono	6.5 μ V
	Stereo	50 μ V
Harmonic Distortion (1100 μ V, 1kHz, 100% Modulation)	Mono	0.3 %
	Stereo	0.5 %
Signal-to-Noise Ratio	Mono	65 dB
	Stereo	60 dB
Selectivity (Alternate Channel)		65 dB
Image Rejection		75 dB
IF Rejection		90 dB
Stereo Separation		40 dB
Capture Ratio		1.5 dB

AM TUNER SECTION

Usable Sensitivity	300 μ V/m
Selectivity (at 1 MHz, \pm 10 kHz)	35 dB
Image Rejection	50 dB
IF Rejection	40 dB
Signal to Noise Ratio	50 dB

POWER AMPLIFIER SECTION

Minimum continuous RMS sine wave power per channel from 20 Hz to 20 kHz with no more than 0.2 % total harmonic distortion into an 8 ohm load.	75 Watts
Sensitivity	
Phono	2 mV
Aux	150 mV
Tape-1, Tape-2, Rec.Out	150 mV
Signal-to-Noise	
Phono	65 dB
Aux	75 dB
Tape-1, Tape-2, Monitor	75 dB
Frequency response \pm 1 dB	
Phono	30 Hz — 15 kHz
Aux	20 Hz — 20 kHz
Tape-1, Tape-2	20 Hz — 20 kHz
Graphic equalizer control range (50 Hz, 250 Hz, 1 kHz, 4.5 kHz, 15 kHz)	\pm 10 dB
Loudness Contour at 100 Hz	8 dB
at 10 kHz	4 dB

GENERAL

Power Requirement	120 V AC \pm 10 %, 60 Hz, 170 W
Overall Cabinet Dimensions	Width 460 mm (18-1/8 in.) x Height 150 mm (5-7/8 in.) x Depth 432 mm (17 in.)

NICKEL CADMIUM RECHARGEABLE BATTERY SPECIFICATIONS

1. Trade Name	: Sanyo Cad-Nic Battery
2. Type	: 4N-100AAS
3. Rate	Power : 90 mA/H
	Voltage : 1.2 V/Cell
Final Discharge Voltage	: 1.0 V/Cell
Charge Current	: Maximum 3.3 mA
Charge Voltage	: 1.35—1.50 V/Cell
Charge Time	: 42—48 hours
Weight	: 40 gr.
Temperature	: 0—45°C.....Charge
	—20—60°C.....Discharge
	—30—35°C.....Preserve

4. General Characteristic Specifications

4-1. Open Circuit Voltage	More than 1.25 V/Cell	: 2 Weeks after completely charging
4-2. Power	More than 300 minutes	: Time when it is 1.0 V/Cell, discharging with 18 mA current after completely charging.
4-3. Exhausted Power	More than 180 minutes	: Time the same as time mentioned above after 500 times of 6 hours charge with 11 mA and 2 hours discharge 23 mA.

OPERATING THE RECEIVER

This section briefly describes the operating control functions. For a step by step explanation of each function refer to Pages 6, 7 and 8.

- LOW FILTER**
If feedback or rumble occurs when using phono, push LOW FILTER switch to the in (ON) position to attenuate this noise. Normally this switch should be in the out (OFF) position.
- HIGH FILTER**
Press this switch in to reduce scratch noise from old records, noisy tape recordings, or FM broadcasts. Normally, the switch should be in the out (OFF) position.
- MONO MODE**
Press this switch to play a mono device connected to the AUX jacks, or to hear a stereo program monoaurally on a single extension speaker.
- LOUDNESS**
Push the LOUDNESS CONTOUR switch in (ON) or out (OFF) as desired. Setting the switch in will restore tonal body and brilliance at low volume levels.
- FUNCTION INDICATORS**
Indicate program source, AM, FM, FM MPX, PHONO, or AUX.

- FM MUTING**
Push this switch in (ON) to reduce interstation noise while tuning an FM broadcasts. For receiving a distant or weak signal station, set the switch to the out (OFF) position.

- PHONES**
For private listening insert STEREO HEADPHONES.

- GRAPHIC EQUALIZER**
Adjust the five controls to provide the sound you prefer.

- TONE DEFEAT**
Push this switch in to defeat the graphic equalizer and to obtain flat frequency response from the amplifier. Push the switch to the out position to restore the graphic equalizer operation.

- SPEAKERS**
Set SPEAKERS switch to A or B or A + B positions, depending on the rear terminals to which your speaker system is connected. Use the PHONES position to turn off your speakers and to listen privately through headphones.
Note: The PHONES jack operates in all positions of the switch. If only one pair of speakers is connected, they will not function if this switch is set for A + B.

- AM/FM CENTER CHANNEL**
Indicates the receiver is tuned to the center of an AM or FM signal.
- AM/FM SIGNAL STRENGTH**
The number of lights indicates the relative strength of the signal.
- FREQUENCY DISPLAY**
Displays the frequency to which the receiver is tuned.
- MHz/kHz INDICATORS**
Indicates the units to be used when reading the frequency display. MHz for FM or kHz for AM.

- FM STEREO INDICATOR**
With the FUNCTION switch in the FM MPX position, this light indicates an FM stereo is being received.
- FREQUENCY SWITCH INDICATORS**
Indicates which of the frequency switches has been selected.
- MEMORY INDICATOR**
Indicates the memory is ready for the entry of a frequency.

- AUTO SCAN UP/DOWN**
Press this switch to start automatic scanning of the tuning frequency up (Right end) or down (Left end).
- SCAN HOLD**
Press this switch to stop the auto scan operation after the desired station is tuned in.

- MANUAL TUNING SLOW UP/DOWN**
Press this switch to manually change the frequency at slow rate up (Right end) or down (Left end).

- MANUAL TUNING FAST UP/DOWN**
Press this switch to manually change the frequency at fast rate up (Right end) or down (Left end).

- MEMORY SWITCH**
Press this switch to ready memory for an entry.

- FREQUENCY SWITCHES**
1. Press one of the switches to store a frequency.
2. Press one of the switches to recall a previously stored frequency.

- TAPE MONITOR**
The TAPE MONITOR switch has priority over the FUNCTION SELECTOR. Keep this switch on the SOURCE position to use the FUNCTION SELECTOR. When you wish to listen to a tape deck connected to TAPE 1 jacks, set this switch to the "1" position. For listening to a tape deck connected to TAPE 2 jacks, set this switch to the "2" position. For duplicating (recording on TAPE 2 from TAPE 1), set the switch to "1 → 2" position.

- BALANCE**
Turn this control either towards LEFT or RIGHT for the best stereo effect.
- VOLUME**
Adjust for desired sound level.

- POWER SWITCH**
Press the POWER button to the in position to turn the set on. Press to the out position to turn the set off. When the power is switched on, a special protection circuit keeps the speakers disconnected for a few seconds to prevent speaker damage.

- RECORD OUT**
Plug a third tape deck into this jack for recording.

- FUNCTION**
Selects the desired program source.
 - AM — AM broadcasts.
 - FM — FM mono broadcasts.
 - FM MPX — FM stereo broadcast.
 - PHONO — Phonograph records, if you have connected a record player to the PHONO jacks.
 - AUX — External source connected to AUX jacks.

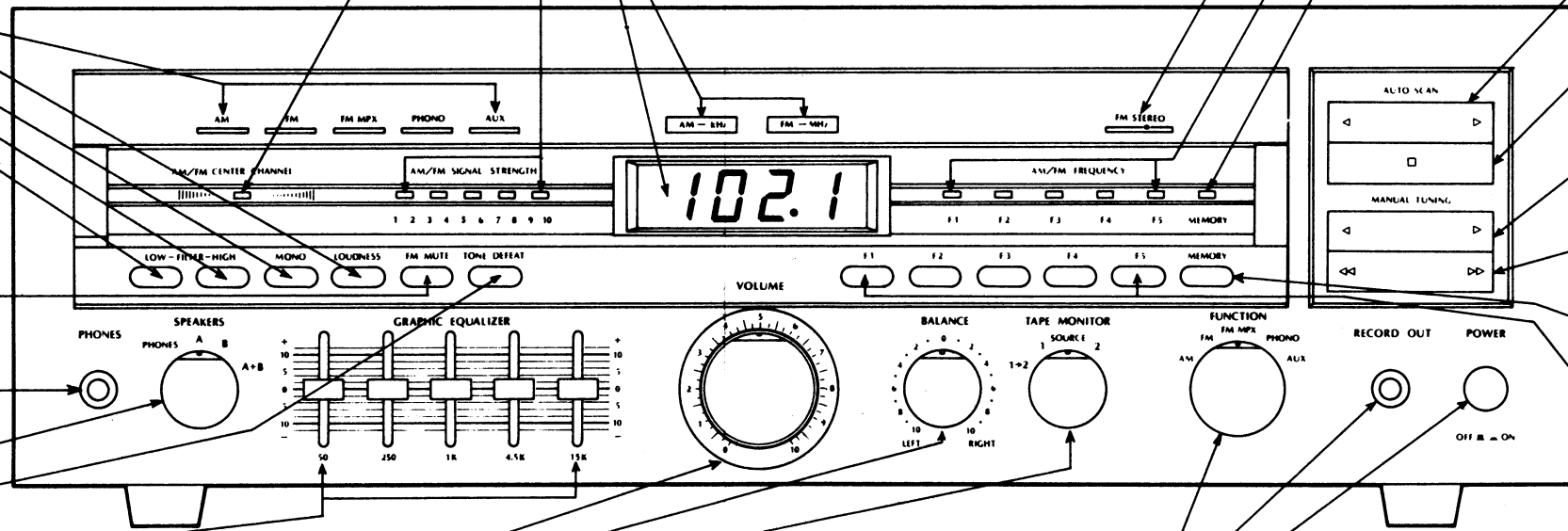

RADIO OPERATION

AM RECEPTION

With the speakers connected properly and the power supply cord plugged into an AC outlet;

1. Set the FUNCTION switch to the AM position.
2. Select the desired speakers with SPEAKERS switch.
Do not place the SPEAKERS switch in a position where no speakers are connected. Also do not use the A + B position unless both the A and B speaker pairs are connected.

MANUAL TUNING

1. Press the left or right end of the MANUAL TUNING FAST UP/DOWN switch. The tuning frequency, which is displayed on the front panel, will go up or down at a fast rate.
As the desired station's broadcasting frequency is approached, release the switch.
2. Press the left or right end of the MANUAL TUNING SLOW UP/DOWN switch. The tuning frequency will change up or down at a slow rate. When the desired frequency is reached, release the switch.

AUTO SCAN TUNING

1. Push the left or right end of the AUTO SCAN UP/DOWN switch. The tuning frequency will continue to change up or down. As a station is tuned in, the auto scan will hold the frequency for 5 seconds, then will continue to scan.
2. When the desired station tuned during the auto scan operation, press the SCAN HOLD switch to stop the auto scan.
3. To resume the auto scan operation, press the AUTO SCAN UP/DOWN switch.

MEMORY TUNING

1. Using the AUTO SCAN or MANUAL TUNING switch, obtain the desired station frequency on the display.
2. Press the MEMORY switch. The MEMORY SWITCH indicator should come on to indicate the memory is ready for the entry.
3. Press any of the F1 through F5 FREQUENCY switches into which you wish to enter the frequency.
The FREQUENCY SWITCH indicator for the switch pressed, should come on to indicate the frequency being displayed is stored in that particular switch position.
NOTE: The FREQUENCY SWITCH must be pressed within 5 seconds after the MEMORY switch is pushed. If the MEMORY indicator has gone out to indicate the 5 seconds have past, repeat Steps 2 and 3 above.
4. To enter additional frequencies into the memories, repeat Steps 1 through 3 above.
5. To tune the receiver to one of the frequencies in memory, press the FREQUENCY switch in which your desired station frequency is stored. The FREQUENCY switch indicator for the FREQUENCY switch being pressed will come on to indicate the receiver is now tuned to the recalled frequency, which is being displayed on the front panel.
NOTE: Do not press the MEMORY switch to recall the stored frequency.
6. To change a frequency in memory, ignore the previous frequency and repeat Steps 1 through 4 above.
NOTE: This receiver contains a back-up battery to maintain the frequencies stored in the memories in case of loss of power.

FM RECEPTION

1. Set the FUNCTION switch to the FM MPX position.
2. Follow the steps in MANUAL TUNING, AUTO SCAN TUNING, or MEMORY TUNING under AM RECEPTION.
3. The number of lights lit in the AM/FM SIGNAL STRENGTH indicator is a guide to the relative strength of the FM signal.
4. If the FM station being tuned is broadcasting a stereo program, the FM stereo indicator will light.
5. If the FM station sounds noisy and the FM STEREO indicator blinks due to insufficient signal strength, turn the FUNCTION switch to the FM position.
6. If you wish to eliminate the interstation noise while you are tuning, push the FM MUTE switch in, but for receiving a distant or weak FM station, leave the switch in its outer position to utilize the maximum sensitivity of this receiver.

AUDIO CONTROLS

With the receiver tuned to a desired AM or FM station as described above;

1. Adjust the VOLUME control for the desired listening level.
2. Turn the BALANCE control to the LEFT or RIGHT for the best stereo effect.
3. Set the five GRAPHIC EQUALIZER controls to adjust the frequency response of your receiver to best suit the acoustic characteristics of your listening room.
The advantage of the GRAPHIC EQUALIZER over conventional tone controls is that with each of the five controls it is possible to control the audio frequency response in narrow and distinct sections.
The frequency sections controlled by the five slide controls have been chosen to yield the maximum control action within the audio frequency range.
50Hz ____ The 50Hz control is very useful to enhance low bass notes as in organ music, and it also offers the possibility of making corrections when a deficiency in bass exists, caused by either a listening room with poor acoustic properties like bass absorbing curtains, carpets and furniture, or by a component part of your system like speaker, cartridge or record or tape with a poor bass response.
250Hz ____ The 250Hz control will allow you to vary the upper bass frequencies.
1kHz ____ The 1kHz control is the presence control and can be used very effectively to emphasize, bring out front, or de-emphasize vocalists.
4.5kHz ____ The 4.5kHz control will add brilliance and clarity to brass instruments and violin.
15kHz ____ The 15kHz control can be used to make up for missing high frequencies absorbed by the environment and to add a natural crispness to music.
4. You may push the LOUDNESS switch in to restore tonal body and brilliance at low sound level. This function can be used with or without the GRAPHIC EQUALIZER. To defeat the GRAPHIC EQUALIZER, push the TONE DEFEAT switch in.

SECTION I — BLOCK DIAGRAM

This receiver system is basically the same design functionally as the typical super-heterodyne receiver system currently being repaired by field service personnel. It is important to keep this in mind during any servicing procedure.

A general description of each of the circuit sections, shown in Figure 1-1, follows:

TUNER BOARD

The Tuner Board contains the AM and FM tuner, 1.F., and detector circuitry, including the multiplex decoder. The AM and FM local oscillators are varactor tuned, so the AM and FM tuning voltages from the Synthesizer Logic Board are input to the Tuner Board. AM and FM oscillator buffered outputs from the Tuner Board let the Synthesizer Logic Board monitor the tuned frequency of the receiver for reference. Mute and stop signal transactions between the Tuner and Synthesizer Logic Boards let the Synthesizer Logic Board know when a station has been properly tuned in and control muting of the detected audio on the Tuner Board. Manual muting of the detected audio on the Tuner Board can be done for interstation noise or weaker stations via the FM MUTE switch on the Audio Switch Board. Signal strength voltage is output to the electronic signal strength meter on the Function Indicator Board. Audio output is directed to the Function Switch Board. The Tuner Board receives power from the Function Switch Board.

MEMORY SCAN BOARD

The Memory Scan Board simply mounts and provides connection to the switches which allow manual control of the tuning system on the Synthesizer Logic Board.

LED DISPLAY BOARD

The LED Display Board contains the memory lamp LED's and the frequency read-out display. These displays are driven by the Synthesizer Logic Board to reflect the current operating status of the tuning system.

FUNCTION SWITCH BOARD

The Function Switch Board receives power from the Amplifier and Power Supply Board, provides switching and power necessary to the tuner board to obtain AM, FM, or FM multiplex operation, and supplies power to the Function Indicator Board. The Function Switch Board receives audio from either the Tuner Board or external phono and tape inputs, and directs them to the Audio Switch Board and tape output jacks, according to the settings of the function and tape monitor switches. The function switch board provides logic levels to the Synthesizer Logic Board which determine the operating mode appropriate to the program source.

SYNTHESIZER LOGIC BOARD

The Synthesizer Logic Board receives its power from the Voltage Regulator Board, and its commands from the user via the switches on the Memory Scan Board and the Function Switch Board. Signals from the Tuner Board inform the Synthesizer Logic Board that an AM or FM station is properly tuned. The correct DC tuning voltages are provided by the Synthesizer Logic Board to the Tuner Board in order to tune the stations programmed by the user. The Synthesizer Logic Board signals its current status to the user via the LED Display Board.

GRAPHIC EQUALIZER CONTROL BOARD

The Graphic Equalizer Control Board simply mounts and provides connections to the five dual-level controls for the equalizer amplifiers on the Audio Pre-Amp Board. The Graphic Equalizer Control Board does not contain the R-L-C networks necessary for equalization, but does provide connection to those components, which are located on the Graphic Equalizer Coil Board.

GRAPHIC EQUALIZER COIL BOARD

Contains the coils and RC networks which, when combined with the controls on the Graphic Equalizer Control Board and the equalizer amplifiers on the Audio Pre-Amp Board, make up the total circuitry necessary for the graphic equalizer feature.

AMPLIFIER AND POWER SUPPLY BOARD

The signal from the Audio Pre-Amp Board is directed to the Amplifier and Power Supply Board which contains the power amplifiers, overload protection circuitry, and the main power supplies. Audio output is directed to the Speaker Select Board through a relay controlled by the overload protection circuitry.

VOLTAGE REGULATOR BOARD

The Voltage Regulator Board provides all the regulated supply voltages for the Synthesizer Logic Board and the +B supply for the auto-scan stop circuitry on the Tuner Board. In addition, it provides power to the memory system and a standby battery system which maintains power to the memory portion of the circuitry in the event of power interruption so that the preset station memory will not be lost.

FUNCTION INDICATOR BOARD

The Function Indicator Board contains the five Signal Strength LED's. These are driven by an IC, which converts the analog signal strength information from the Tuner Board to a digital signal which is encoded to light a number of LED's relative to the signal strength of the station being received. The Function Indicator Board receives power from the Function Switch Board for the signal strength indicator drive circuitry and for the appropriate function indicator lamps.

AUDIO SWITCH BOARD

The Audio Switch Board receives the audio signal from the Function Switch Board and directs it to the Audio Pre-Amp Board. The Audio Switch Board also mounts and provides connection to the low and high filter, mono, loudness, FM mute, and tone defeat switches. The front panel record output jack is driven by the emitter followers on the Audio Switch Board.

AUDIO PRE-AMP BOARD

The Audio Pre-Amp Board contains the amplification and buffering needed for the graphic equalizer section, and receives power directly from the Amplifier and Power Supply Board. The equalizer amplifier sections on this board are bypassed if the tone defeat switch on the Audio Switch Board is used. The audio signal from the Audio Switch Board is otherwise passed through the equalizer amplifiers, which modify the tone of the audio signal according to the equalizer control settings, and sent to the Amplifier and Power Supply Board.

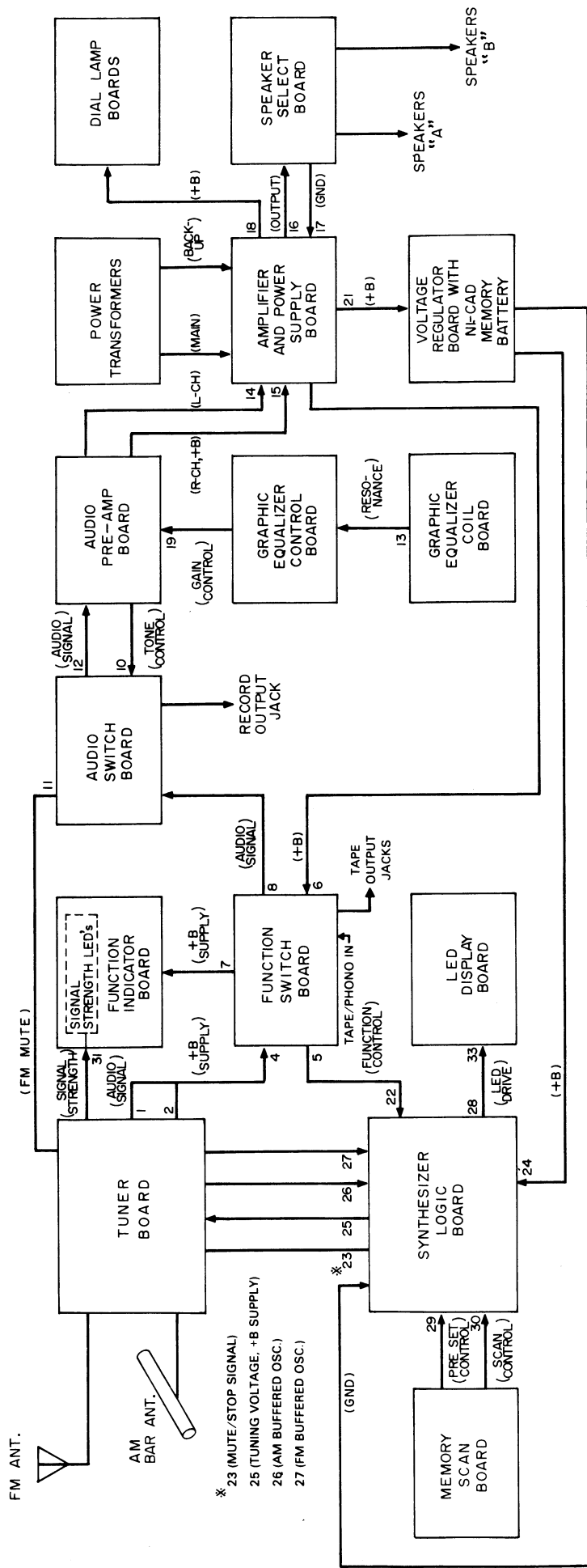

FIGURE 1-1. BLOCK DIAGRAM

SECTION II — GATING

Of the logical building blocks available to digital circuit designers, gates are some of the most commonly used. This receiver employs four basic types of gates. Please note that in all of the logic used in this design, a logical "high" or "one" is approximately +5 volts, and a logical "low" or "zero" is approximately zero volts.

DIODE "OR" GATE

The diode "OR" gates used in this receiver appear in the configuration shown in Figure 2-1. They very simply provide that either or both of two circuits may provide a "high" or +5 volt input condition to produce a "high" or +5 volt output condition. Note that if either or both of the inputs are at the +5 volt level, the diode(s) are forward biased and they therefore conduct. As they will have about a 0.6 volt drop across them when conducting, the gates output level will be about 4.4 volts.

DIODE "OR" GATE TRUTH TABLE

A	B	OUT
0	0	0
0	1	1
1	0	1
1	1	1

SILICON DIODES REQUIRE AT MIN. 0.6 VOLTS FORWARD BIAS TO TURN THEM ON

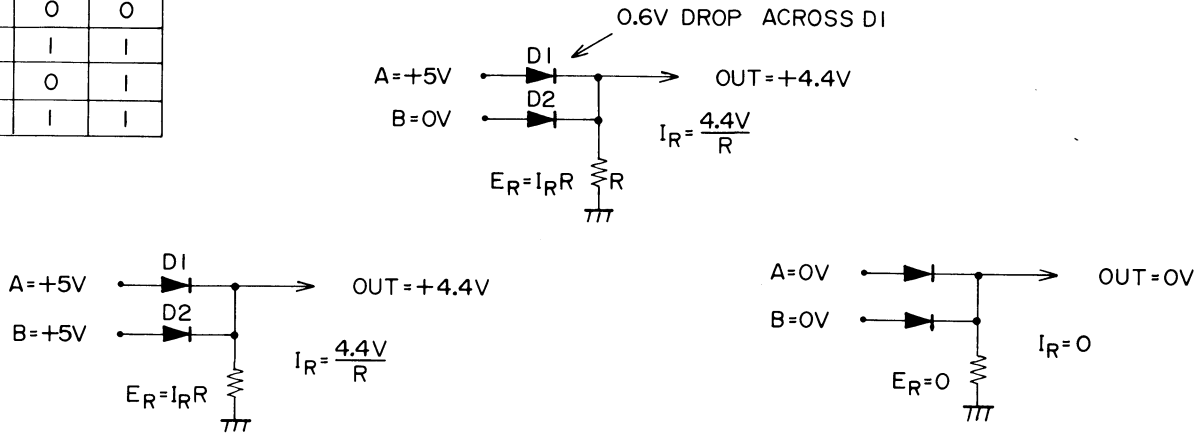

FIGURE 2-1. "OR" GATE

"AND" GATE

The "AND" Gates used in this receiver are packaged in fours, they are then referred to as "QUAD AND GATES".

They appear in the schematic for this receiver as shown in Figure 2-2. They provide that there will be no "5 volt" output unless both inputs are "high".

a

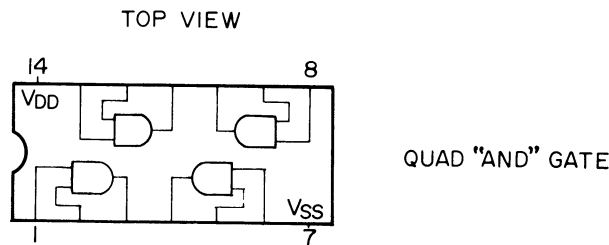

b

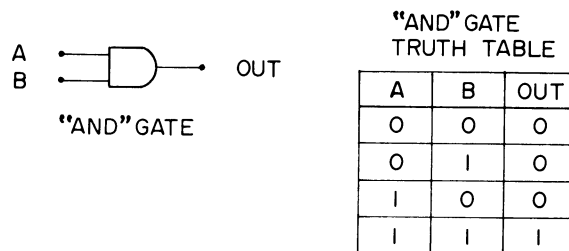

FIGURE 2-2. "AND" GATE

INVERTER

The INVERTER is the simplest gate of all, a "high" input results in a "low" output and vice versa.

The inverters used in this receiver are typically employed in packages of seven. (Figure 2-3)

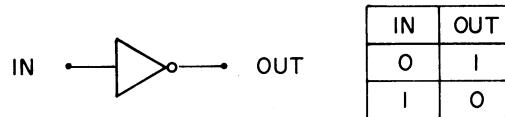

FIGURE 2-3. INVERTER

NOT AND, $\overline{\text{AND}}$, OR "NAND" GATES

The "NOT" or inverse function is applied here to the "AND" gate, to result in the "NAND" gate. It is the equivalent of an "AND" gate, followed by an inverter.

Its truth table can be seen in Figure 2-4 to have an output column which is just the opposite of that for the "AND" gate for the same sets of inputs.

a

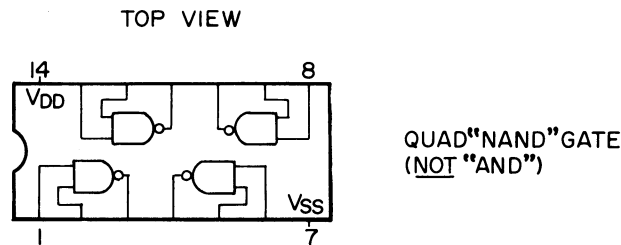

b

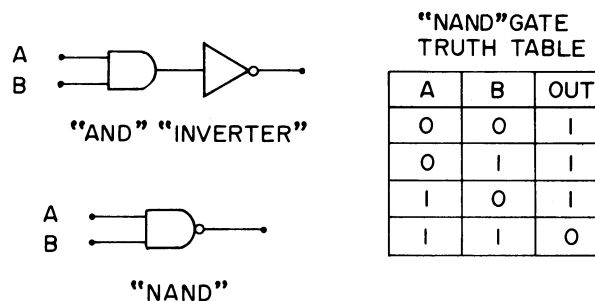

FIGURE 2-4. "NAND" GATE

SECTION III — TUNER BOARD

FM TUNER

The FM Tuner is a straightforward superheterodyne design with varactor tuning. The only departure from the usual circuitry is that this FM tuner provides several output signals not normally produced by component stereo receiver FM tuners. A buffered FM oscillator signal is provided to the Synthesizer Logic Board for reference, mute drive is used to control a center channel indicator and manual muting, and a DC level proportional to FM signal strength is output to signal strength display circuitry on the Function Indicator Board. Refer to the Tuner schematic on page 25.

Varactor tuning is provided by adjusting the DC FM tuning voltage at terminal J3 of the tuner circuit board which in turn determines the capacitance of identical varactor diodes D1 through D4. D1 and D2 respectively tune the input and output tuned circuits of the FET RF amplifier Q1 over a frequency range of from 88.1 to 107.9 MHz. Similarly, D3 tunes the input circuit of the mixer, Q2. D4 is used to tune the oscillator, Q3 over a frequency range of from 98.8 to 118.6 MHz such that for any given tuned RF/mixer frequency it will be 10.7 MHz higher. The oscillator signal is fed to the base of the mixer (Q2) from the anode of D4 through C13.

Oscillator signal is also coupled from the emitter of Q3 through C25 to the base of the buffer, Q4. The buffered oscillator output is then taken from the emitter of Q4 and directed to J6 for use in the synthesizer circuitry.

The I.F. signal is routed from the collector of the mixer (Q2), through the 10.7MHz ceramic filters (CF1 and CF2) to Q5, and from there to pin 1 of IC1 after passing through another ceramic filter, CF3.

IC1 further amplifies and detects the signal. However, there are also many other functions performed by IC1 — refer to Figure 3-1.

A muting input (pin 5) allows muting during automatic scan between stations, and provides for the option of manually muting any signal not strong enough to provide acceptable reception.

Note that IC1 also provides a unique mute output signal.

It is a DC level which becomes "low" in response to a properly tuned signal of specific strength. It appears at pin 12 of IC1 and is the second of the two output signals not normally produced by component stereo receiver FM tuners; a "low" signifies "good signal," a "high" results in muting.

The "good signal" output of IC1 pin 12 is used to control two features. It is applied to the base of Q11 which, if made "low," causes the circuitry to stop scanning if it is in the automatic scan mode. (This also results in causing the AM/FM CENTER CHANNEL lamp to be turned on). The second function of this output is that it can, if "high" (about +5 volts) provide for the option of manually muting any weak signal. On a weak signal, IC1 pin 12 is "high" — if the front panel mute switch (S9 on audio switch board) is on, this +5 volt level is applied via the mute switch to one input of the diode "OR" gate comprised of D13 and D15. The "high" output of this gate is applied to the "mute" input (pin 5) of IC1 and thereby mutes the weak FM signal.

Pin 13 of IC1 provides a DC output proportional to FM signal strength and is used for two purposes. It determines the mute level, or size of signal determined to be too weak for useable reception as adjusted by SVR 1. It also is applied to an analog-to-digital converter-decoder/lamp driver circuit (IC701 on the function indicator board) which converts signal strength to an indication, by number of lamps, on a scale of from zero to five lamps, of the signal strength of the tuned FM signal. Finally, the FM section includes a multiplex circuit, contained in IC2. See Figure 3-2. IC2 will normally attempt to decode an FM stereo signal into its respective left (pin 4) and right (pin 5) channels. It is disabled from doing so by application of +5 volts to pin 12, the "DISABLE" input. This input is controlled by the diode "OR" gate comprised of D10 and D11. A "weak signal" indication of +5 volts from IC1 pin 12 via D10 or a "MONO" indication of +5 volts from the function switch via D11 will disable the multiplex chip IC2, and mono reception will result.

AM TUNER

The AM Tuner is also a varactor-tuned superhet (see Figure 3-3). Tuning voltage applied to varactor diodes D5 and D6 controls the frequency of both the RF Amplifier and oscillator. The RF amplifier, oscillator, IF amplifier and AGC amplifier functions are all contained within IC3. Note that a portion of the oscillator signal is taken from pin 5 of IC3 and applied to the Buffer (Q13). From there it is sent to the Synthesizer Logic Board for other uses.

The amplitude of the I.F. signal leaving pin 7 is dependent on signal strength. Therefore, it can be used to develop a signal strength lamp indication and control scanning, as well as be used in the audio channel.

Refer to the Tuner Schematic on page 25. The signal from IC3, pin 7 is detected by D16 and coupled to the base of Q7 through R77 and C75. The signal is also sent from pin 7 to the 455KHz transformers T5 and T6 and from there to the base of Q8. It is amplified by Q8, and detected/doubled by detector/doubler D17 and D18. Detector/doubler D17-D18 produce an AM signal strength-dependent DC voltage at the top of SVR 5 (AM SIGNAL INDICATION ADJUSTMENT) and SVR 6 (AM AUTO SCAN STOP ADJUSTMENT). The variable output of SVR 5 is applied out J27 to the A-to-D converter (IC701 on the Function Indicator Board) which in turn results in LED signal strength indication. The variable output of SVR 6 is applied to Q9/Q10 which, if Q10 is turned "off," causes the circuitry to stop scanning in the automatic scan mode. This is accomplished, as it was in FM, by the fact that if either the AM "stop scan" transistor Q10 or the FM "stop scan" transistor Q11 is turned "off" (Output made "high" or +5 volts) its output, via diode "OR" gate D20/D21 will turn on Q12 and produce the "low" stop scan level "SQU" as well as drive the AM/FM channel indicator lamp "on" (see Figure 3-1.)

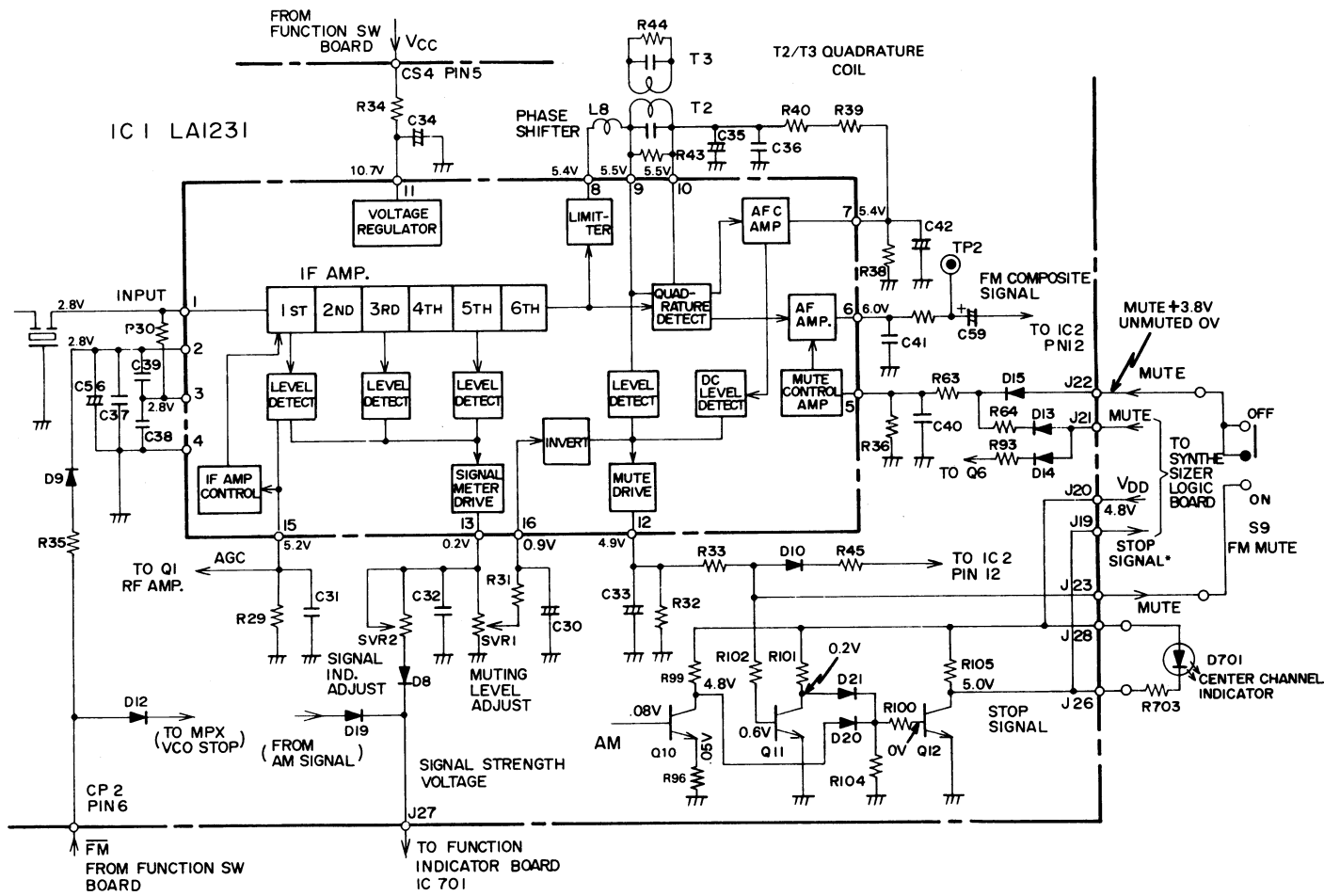

*SEARCH STOP 4.5V 0V

FIGURE 3-1. FM IF AMP & DETECTOR

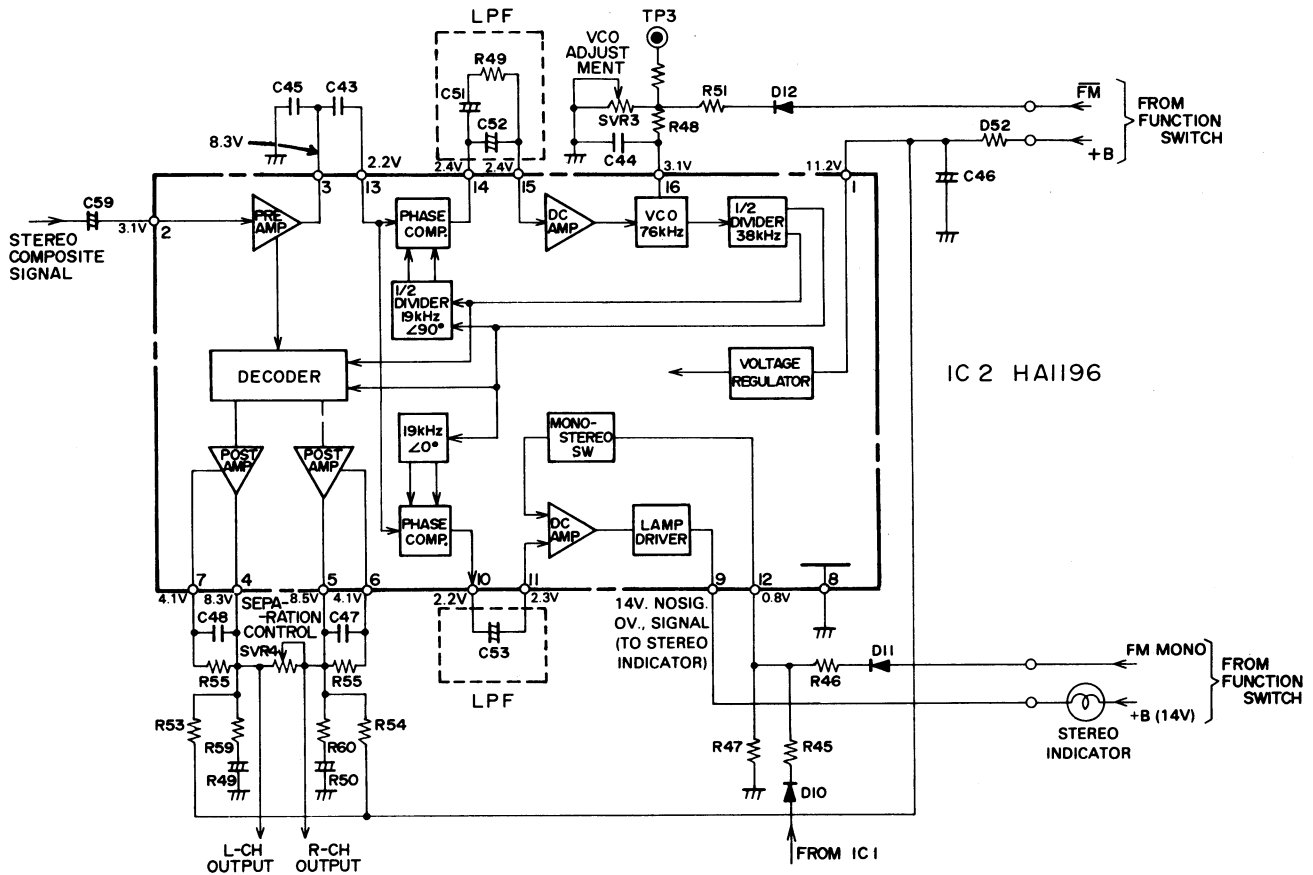

FIGURE 3-2. FM MULTIPLEX DECODER

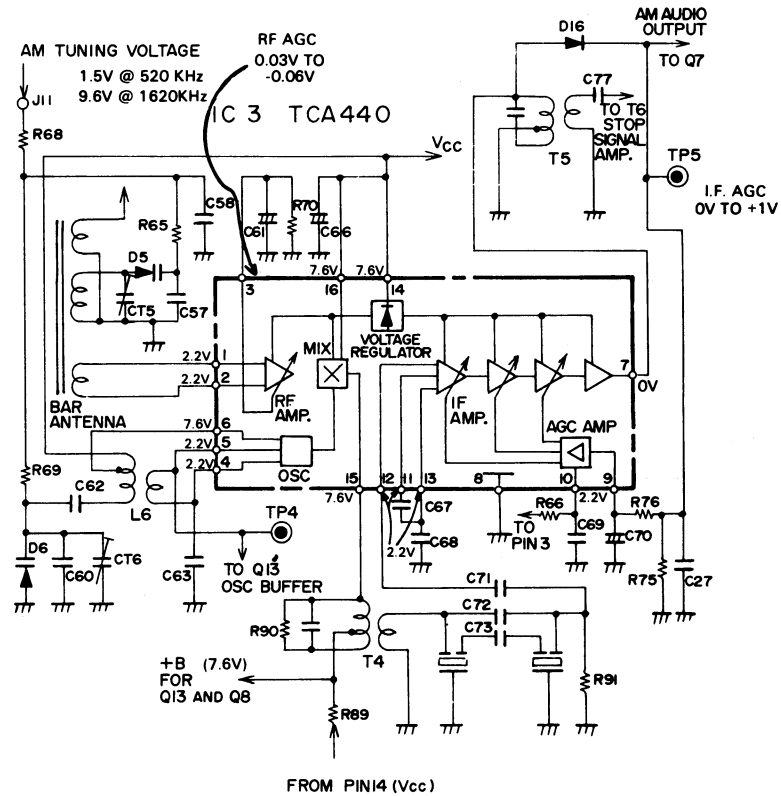

FIGURE 3-3. INTERNAL BLOCK DIAGRAM OF IC3

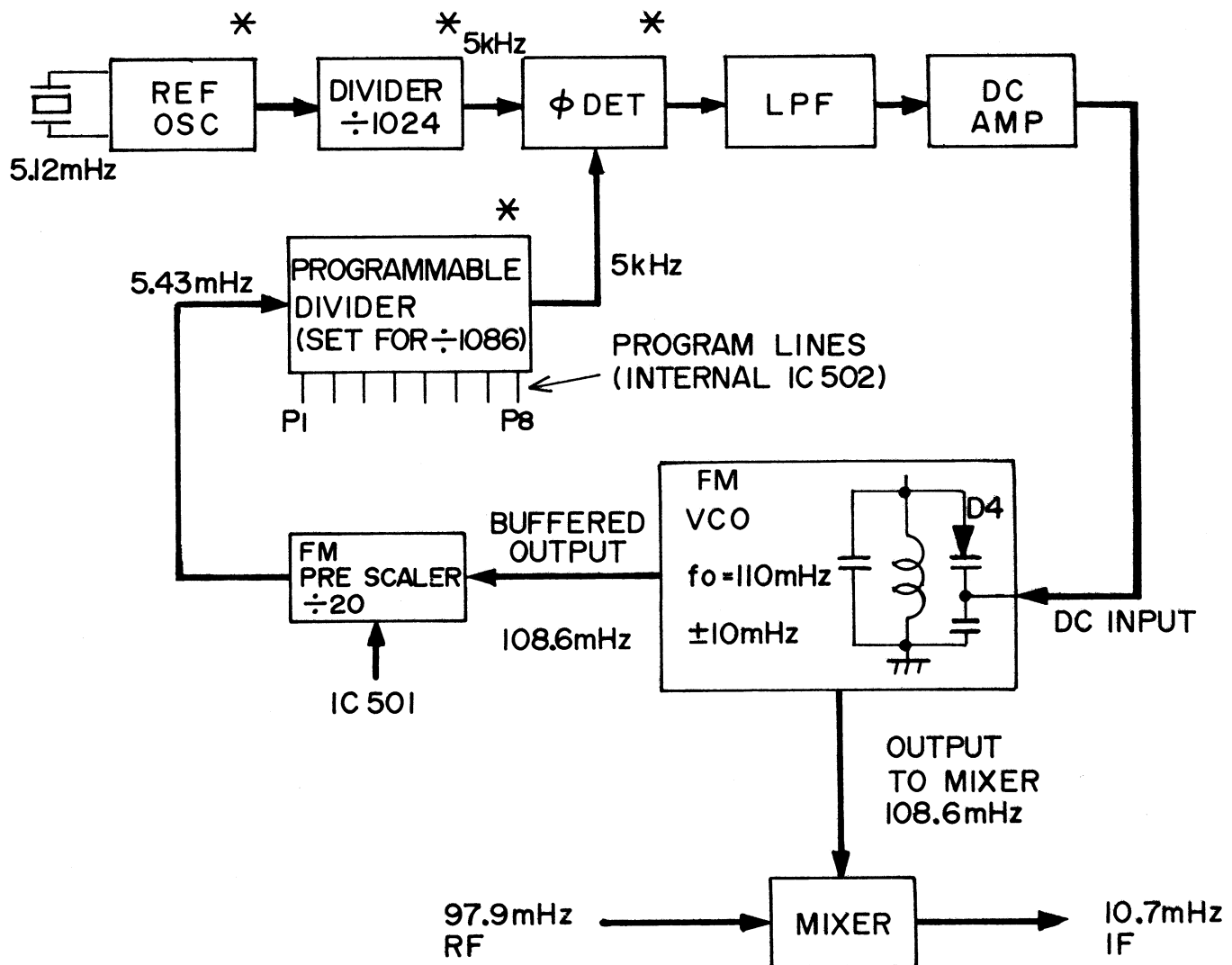

FIGURE 4-1. PHASE-LOCKED LOOP

SECTION IV — THE PHASE-LOCKED LOOP

The 9259 LXI SERIES receiver employs Phase-Locked Loop Circuitry. The term "Phase-Locked Loop" (PLL) is widely applied to various chips and circuits, however, rarely would the entire loop be found all in one place, or, all on one chip. Success in servicing PLL circuitry depends on understanding the basic circuit concept and on locating all of the separate blocks that make up the complete loop. Please refer to Figure 4-1. The example shown is for FM operation. The blocks marked with an asterisk (reference oscillator, divider, phase detector, and a programmable divider) are all inside the 28-pin LSI (large scale integration) chip IC502. IC502 is located on the shielded Synthesizer Logic Board. The LSI, low-pass filter, DC Amplifier and FM pre-scaler will be found on the Synthesizer Logic Diagram (Part A).

The crystal-controlled reference oscillator, divided by a factor of 1024, provides a highly-stable 5kHz. reference. The phase detector determines the "coherence" or degree of synchronism, between the FM VCO (FM local oscillator) and the reference. The FM VCO is designed to be free-running at about 110MHz., and is tuned to the exact frequency desired by varactor diode D4. When the frequency of the FM VCO (after being divided by the pre-scaler and programmable

divider) and the 5kHz reference are equal, and the relative phase angle between them is constant, the phase-locked loop is said to be "in lock." The divider is shown programmed for a divide ratio of 1086. The divide ratio is established inside IC502 when the tuning scan is stopped at 97.9MHz, or a memory button is depressed which recalls the displays 97.9. When 97.9 (divide-by 1086) is first selected, the FM VCO may not be operating at 108.6MHz (the FM VCO frequency needed to produce 10.7MHz mixer output with 97.9MHz RF). Then, an error signal is generated by the phase detector and fed to the low-pass filter (LPF). The error voltage is initially a "beat note" equal to the frequency difference between the 5kHz reference and the divided-down FM VCO.

This is detected and amplified by the "charge pump" or "DC amplifier" and applied to the DC control input to the VCO in such a polarity as to drive the VCO frequency toward the frequency of the input signal. Finally, the beat note is "nulled" and the error signal is just a DC voltage proportional to the phase difference between the VCO and the reference. When the DC voltage is minimized, "lock" is achieved. The VCO is "phase-locked" to the input signal.

Using the divider scheme, we can obtain many crystal-controlled frequencies from one crystal oscillator and a phase-locked loop.

SECTION V — SYNTHESIZER LOGIC, MEMORY SCAN, AND LED DISPLAY BOARDS

SYNTHESIZER LOGIC BOARD

In detail, the operations on this board are extremely complex, due to the internal functions of IC502. Fortunately, no explicit details of the various controllers and memories within IC502 are necessary for service considerations.

A rough block diagram and a pin configuration diagram are included for reference purposes in Figures 5-3 and 5-4. Refer to the Synthesizer Logic Diagrams (Parts A and B) among the Technical Data Sheets at the back of this manual for reference during the discussion of this section, and Figure 5-1 located on the next page, which gives a simplified view of the functions of the logic, memory scan, and LED display boards.

IC502 TUNING SYSTEM

It should be noted that the controller within IC502 determines all tuner functions of this design. The only control over these functions is that afforded by the front panel controls either directly, or indirectly through logic in IC's 505, 506 and 507. These control signals are applied to the only control input to the tuning circuitry, input port, K1-K2-K3. This would seem to limit the capability of the chip to only eight commands in a 1-2-4 sequence from 0-0-0 through 1-1-1.

This is not the case however, because IC502 is structured within to interpret a given command in a different way, depending on the time period during which the command is given. There are six time periods to consider (see Figure 5-2), D1 through D6. There are then 48 possible commands that could be interpreted by IC502. Not all of them will be used in this receiver. When the receiver is first turned on in either AM or FM/MPX functions, IC502 is alerted via the function switch, D503, and "AND" gate 1-2-3 (pins 1, 2 and 3) in IC505 whether AM or FM is selected (during time period D6). IC502 then recalls from within its memory the last station listened to in that mode.

In addition to the last station selected, memory circuitry within IC502 also stores frequencies (divide ratio) for five each AM and FM stations. IC502 programs its divider circuitry for the divide ratio which results in the desired station's frequency to be selected by the tuner. It is important to remember here that the phase lock loop, which includes the tuner's oscillator, will tune to a frequency which is totally dependent on the dividing ratio of the programmable divider which is inside IC502 and whose divide ratio is controlled from within IC502.

The only effect external controls (via input port K1-K2-K3) have is to indicate that the divide ratio is the desired one and to stop, or that it is not the desired one and to change the divide ratio.

MEMORY SCAN CIRCUITRY

There are fourteen switches on the memory scan board. They are interconnected either directly or through diode "OR" gates to provide nine signals of either zero or +5 volts to the logic board. The inputs to the board are combinations of VDD (+5 volts) and the timing pulses D1

through D4. The outputs from the memory scan board are to the programming input port K1-K2-K3 of IC502, and to the logic gates IC505, IC506 and IC507 on the synthesizer logic board.

Outputs of the logic gates are either time dependent (switches connected to timing pulses D1 through D4) or they are time independent (switch connected to VDD).

A simple example upon which to base the explanation of the interaction between the memory scan switches and circuitry, and the LSI IC502, is as follows:

Depress frequency switch F2. You have connected line D3 to line K2. At time D3, K2 will then be high, K1 and K3 low. You have thereby requested IC502 to set the divide ratio to that stored for F2. All other control functions are developed in a similar fashion, some depending upon logic gates IC506, IC507 and IC508, and some not.

Note that gates "1-2-3, 4-5-6, 8-9-10" on IC507 are wired as a low-frequency (0.5 second period) square-wave generator or oscillator. If a "fast scan" control panel button is pushed, only the appropriate DIRECTION is signalled. For example +5 volt output at the "UP" output terminal is directed to K1 via gate "8-9-10" in IC506 during D1 if "Manual Fast Up" switch is depressed. A fast scan of frequencies upward is thereby provided. If a "Slow scan" control panel button is pushed however, the DIRECTION signal is gated with the LOW FREQUENCY OSCILLATOR to produce an interrupted DC level and thereby a slow scan. To summarize, when any of the switches on the memory scan board are depressed, the appropriate memory or scan mode is thereby selected.

LED DISPLAY

Refer again to Figure 5-1. Remember that there are the six timing pulses D1 through D6 which were previously discussed and which are referred to as digit driver outputs of IC502. D1 through D4 provide a common connection to the rightmost through the leftmost LED frequency display digits respectively. Now there are 24 segments in the frequency display including the decimal point. This would normally require 24 connections to the display plus one common connection for a total of 25.

Because of the fact that only one digit is displayed at a time (the right-most only during D1, the second from right during D2,) only 12 leads are required to actuate the display. There are eight segment driver outputs in addition to the four digit driver outputs used. The digits selected during each time interval are determined inside IC502 as a function of the current divide ratio. Then, at the time appropriate to the segment driver outputs, the appropriate segments of each digit are turned on, one digit after another, for 400 micro-seconds and are turned off 3200 micro-seconds (refer back to Figure 5-2). Similarly, if one of the stored frequencies has been selected, its appropriate indicator LED will be actuated by appropriate segment driver S1, 2, 3, 4 or 5 during time period D6, and the decimal point, in the FM mode, is actuated by the segment driver output S8 during time period D5.

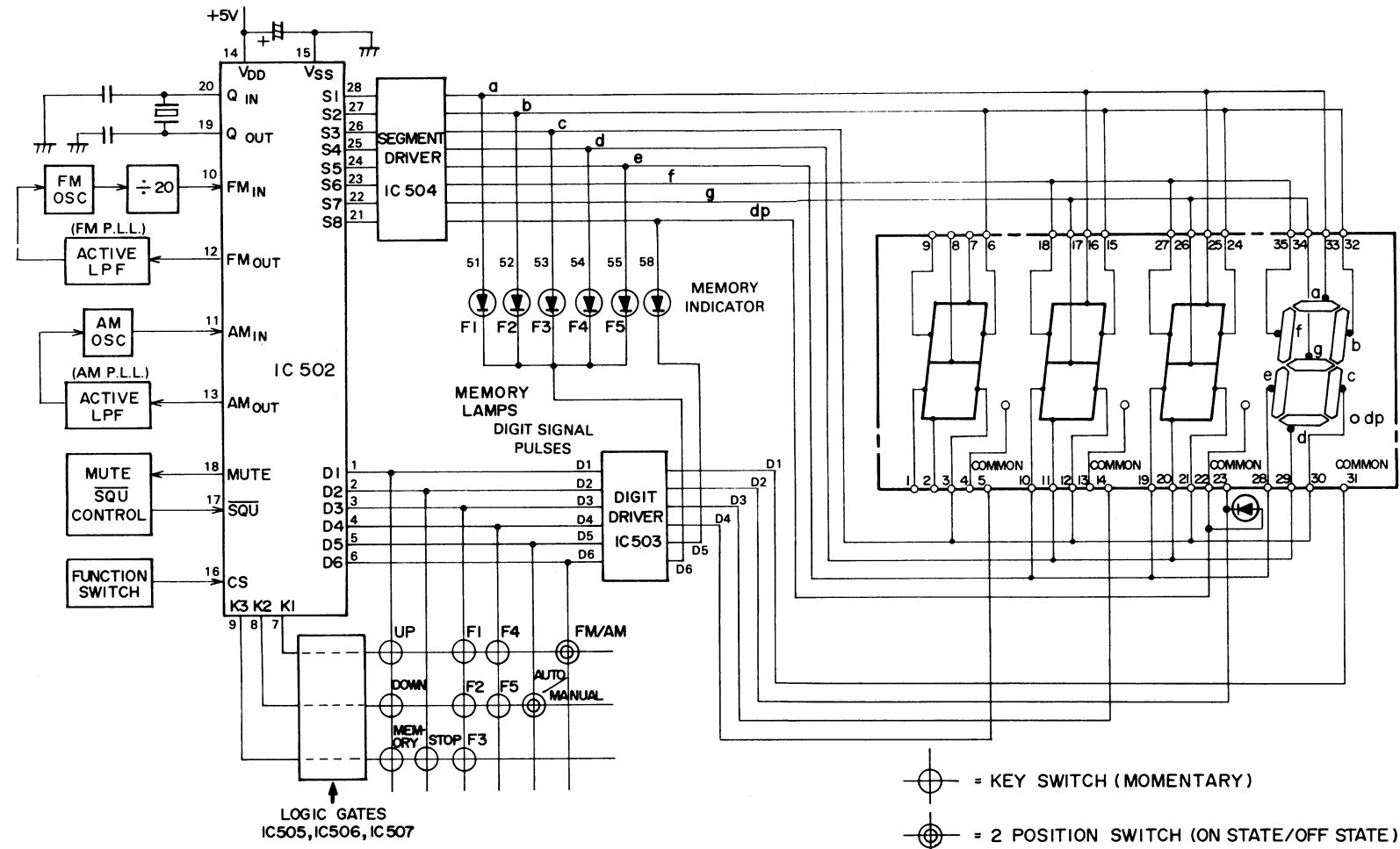

FIGURE 5-1. SYNTHESIZER LOGIC SYSTEM

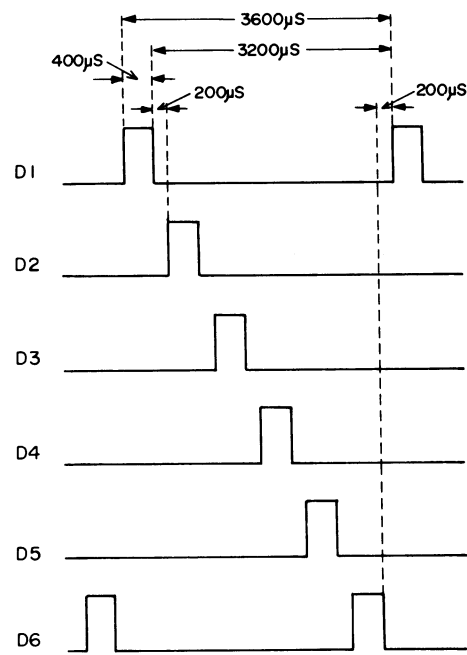

FIGURE 5-2. TIMING CHART OF DIGIT SIGNAL

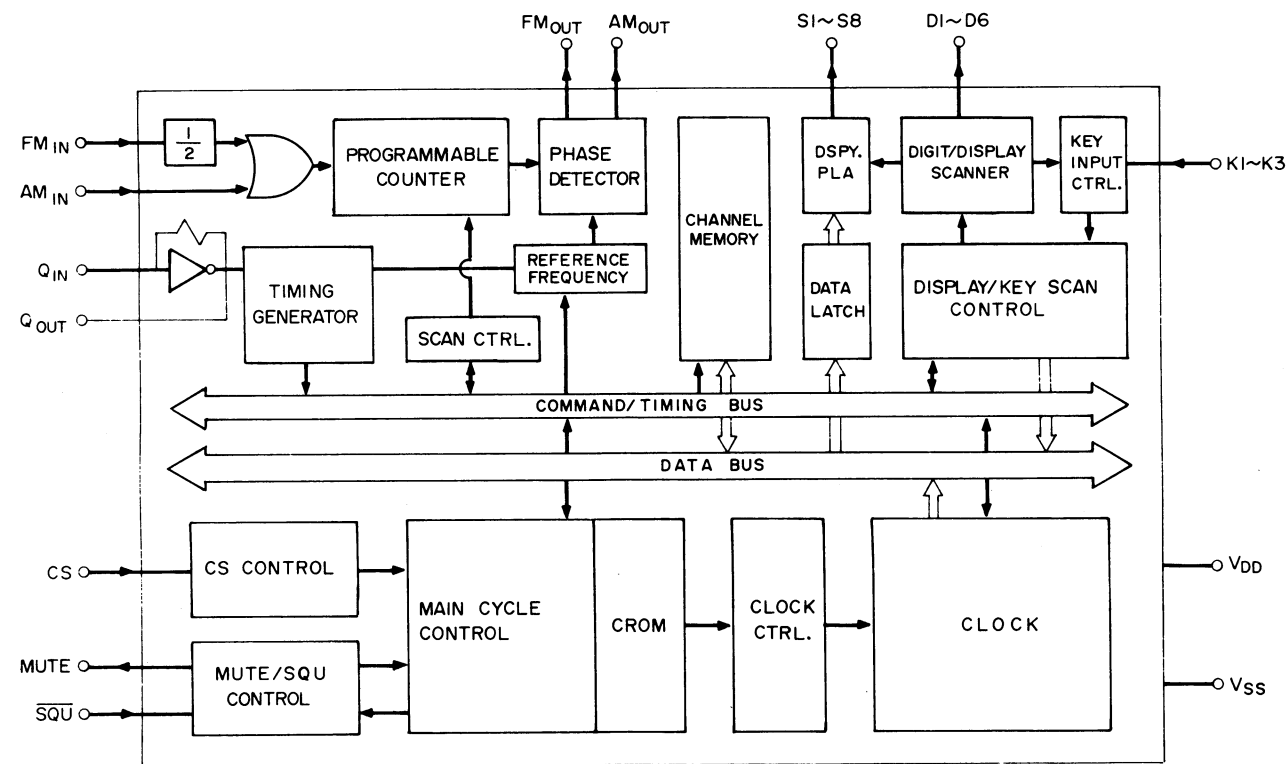

FIGURE 5-3. SC3162 BLOCK DIAGRAM (IC502)

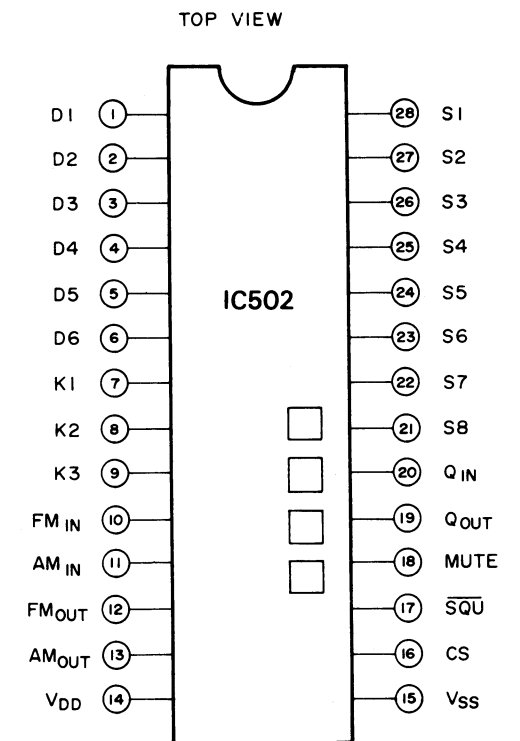

FIGURE 5-4. SC3162 PIN CONFIGURATION

SECTION VII — AUDIO SWITCH, PRE-AMP, AND EQUALIZER BOARDS

EQUALIZER

Please refer to Figure 7-1. It is an example schematic of a 50 Hz graphic equalizer based on circuitry located on the audio pre-amp board, and on the graphic equalizer control and coil boards. Now, at resonance, a series resonant circuit is a short circuit. Note that when the wiper of the equalizer is moved toward the junction of emitter resistors R5 and R6, a 10 micro-Farad capacitor C3, is placed in parallel with R6. This decreases negative feedback for the transistor and thereby increases its gain at 50 Hz.

Moving the wiper toward the junction of collector resistors R3 and R4 however, bypasses or decouples the 3300 ohm portion of the collector load at the resonant frequency, thereby decreasing gain at resonance.

The remainder of the circuitry on these boards will be recognized as the typical emitter followers, loudness, and filter circuitry.

Note that the mono/stereo switch is a pre-amp ganging switch and has no effect on the tuner circuitry.

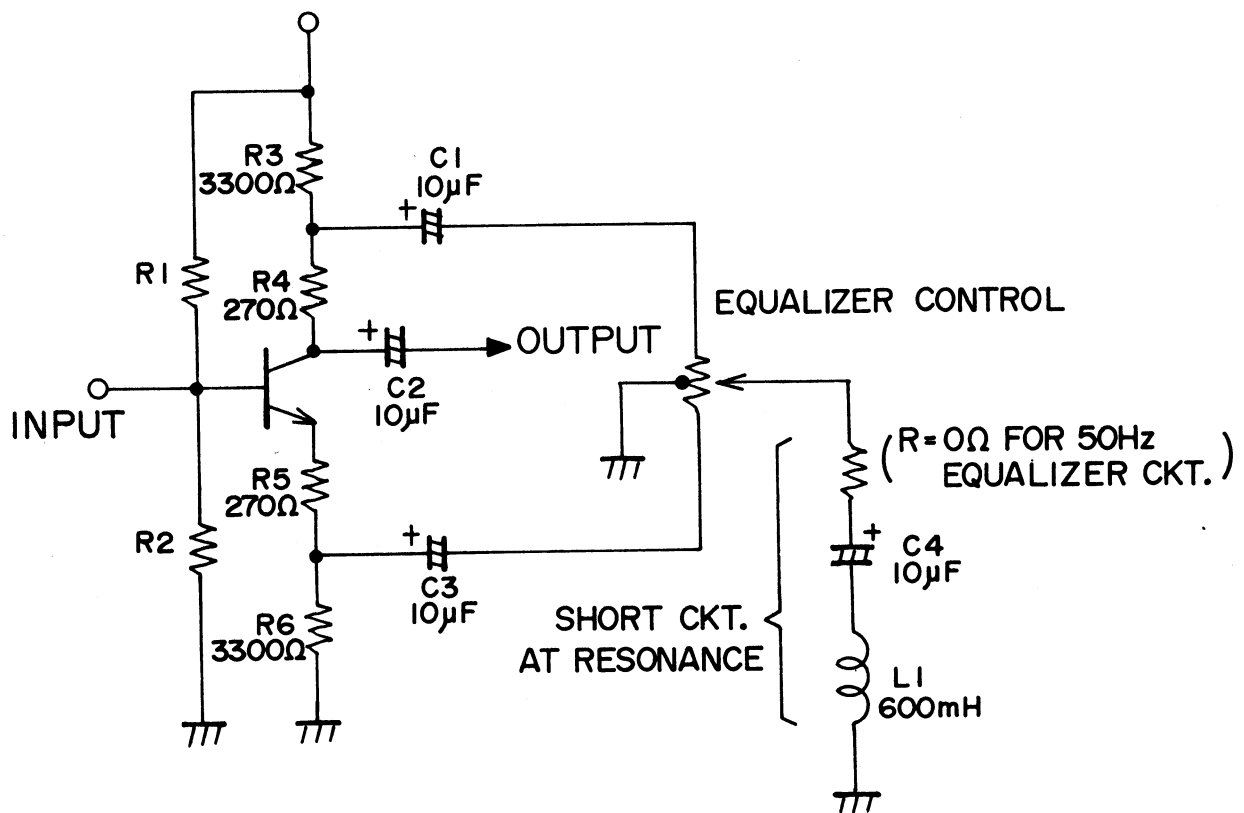

**FIGURE 7-1. GRAPHIC EQUALIZER
(50Hz COMPONENTS ONLY SHOWN)**

SECTION VIII — AMP/POWER SUPPLY BOARD

NOTE: Refer to the Amp/Power Supply Schematic on pages 51 and 52.

AMPLIFIER

The amplifier section is very straightforward and consists of pre-driver transistors Q301 and Q302, driver IC301, and power amplifier IC's 302 and 303. The schematic of Figure 8-1 shows the internal circuitry of the IC's and the signal path through them. The amplifier output is connected to the speakers via relay RY301 and the front panel "SPEAKERS" switch S2 (see Speaker Select Switch board). If two speaker systems are connected to this receiver, they become connected in series in the "A + B" position of S2. If only one speaker system is connected, there will be no sound in the "A + B" position. If relay RY301 is released, all speakers are disconnected from the amplifier. Relay RY301, driven by IC304, comprises a "SPEAKER PROTECTION" circuit which protects not only the speakers, but also protect the amplifier itself.

SPEAKER PROTECTION CIRCUIT

Referring to Figure 8-2, note that inside IC304 there is a "NOR" gate with inputs A, B, and C. A "NOR" gate is simply an "OR" gate followed by an inverter.

Since an "OR" gate provides a "high" output if any or all inputs are "high" or +5 volts, and a "low" or zero volts output if all inputs are "low", it follows that the output from "NOR" gate A-B-C will be "high" as long as all three inputs are low or zero (see truth table in Figure 8-2). The high output from the NOR gate is used to cause the relay driver to be turned ON and pull in relay RY301 to connect the speakers. If any of the inputs A, B, or C goes high however, the output of the NOR gate goes low, and the relay driver is turned off. This drops relay RY301 and disconnects the speakers. There are four functions to be considered when discussing the speaker protection circuitry — there are inputs to the NOR gate and the fourth relates to biasing the relay driver.

RELAY DRIVER BIAS

To prevent undesired "popping" or "thumping" noises during turn-on, relay RY301 is prevented from pulling in until all other circuit time constants have settled to the correct levels. This is done by supplying the bias to the relay driver (IC304 pin 8) through a long time constant network (R361-C382) to keep the relay driver off for several seconds after turning on the receiver.

AC DETECTOR

Conversely, when power is turned off, it is desirable to disconnect the speakers right away. This is done by sensing for the presence of AC power. A DC level provided by D351-R358-C379 to the input (IC304 pin 5) of the AC detector circuit, causes the output of the DC detector circuit to be at a logical "low" level. Then, If power to the receiver is turned off, the DC level at pin 5 goes to zero, the AC detector output goes high, and the speakers are disconnected.

DC OFFSET DETECTOR

The DC offset detector provides a logical low at its output as long as its input (IC304 pin 4) stays within a range of plus or minus 1.2 volts DC. If that voltage range is exceeded, as sensed through R337 and R338 due to an output IC imbalance or failure, then the output of the DC offset detector goes high and the speakers are disconnected.

OVERLOAD PROTECTION

Overload protection is provided using a latch circuit, whose input is at pin 6 of IC304.

When the receiver is first turned on, the latch output is always low. If the voltage at the latch input ever exceeds 1.2 volts DC, it latches its output to a logical high condition and the speakers are disconnected. Receiver power must then be turned off for a few moments in order to restore operation.

The voltage input to the latch circuit is that developed across resistor "RL" and is a function of the collector current of Q353. If the voltage across either R329 or R330 becomes great enough to turn on either Q303 or Q304, Q353 will be turned on via diode or gate D301-D302.

Turning on Q353 in this way increases the voltage across RL to greater than 1.2 volts thereby tripping the latch and disconnecting the speakers.

POWER SUPPLY

The power supply section consists of the usual rectification and voltage regulation circuitry. One unusual feature however, is the provision for continuation of power to IC502 in the event of power interruption (up to several days) so that the preset station memory will not be lost. Specifications for the NiCad battery (mounted on the voltage regulator board) are given on page 2.

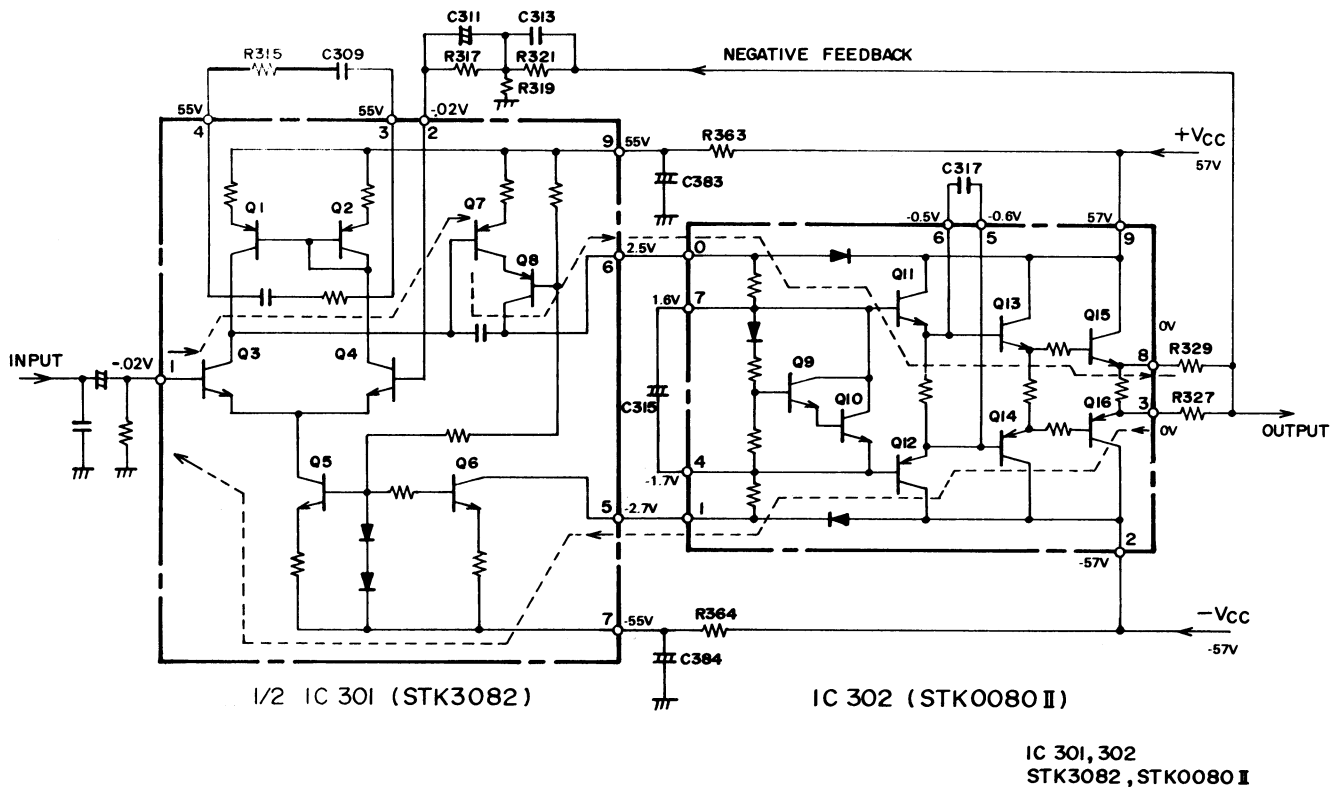
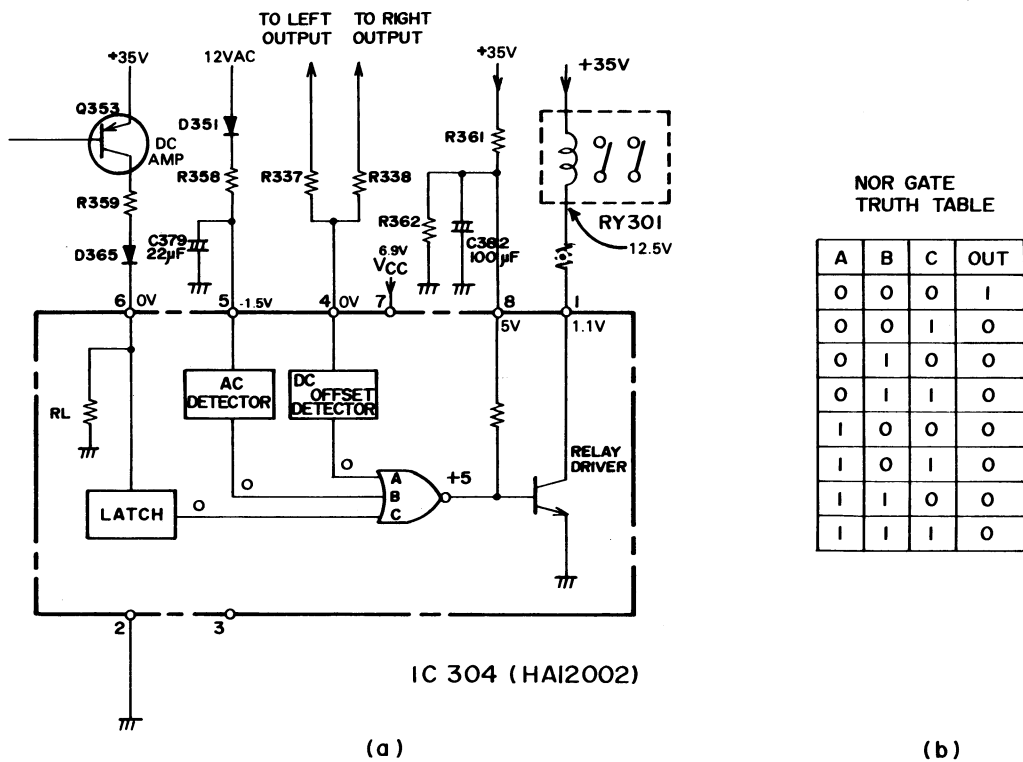

FIGURE 8-1. POWER AMP SECTION



NOR GATE TRUTH TABLE

A	B	C	OUT
0	0	0	1
0	0	1	0
0	1	0	0
0	1	1	0
1	0	0	0
1	0	1	0
1	1	0	0
1	1	1	0

FIGURE 8-2. SPEAKER PROTECTOR

*3.4V @ 88.1MHz
9.6V @ 107.9MHz

564.92590900

MODEL NO 564.92590900

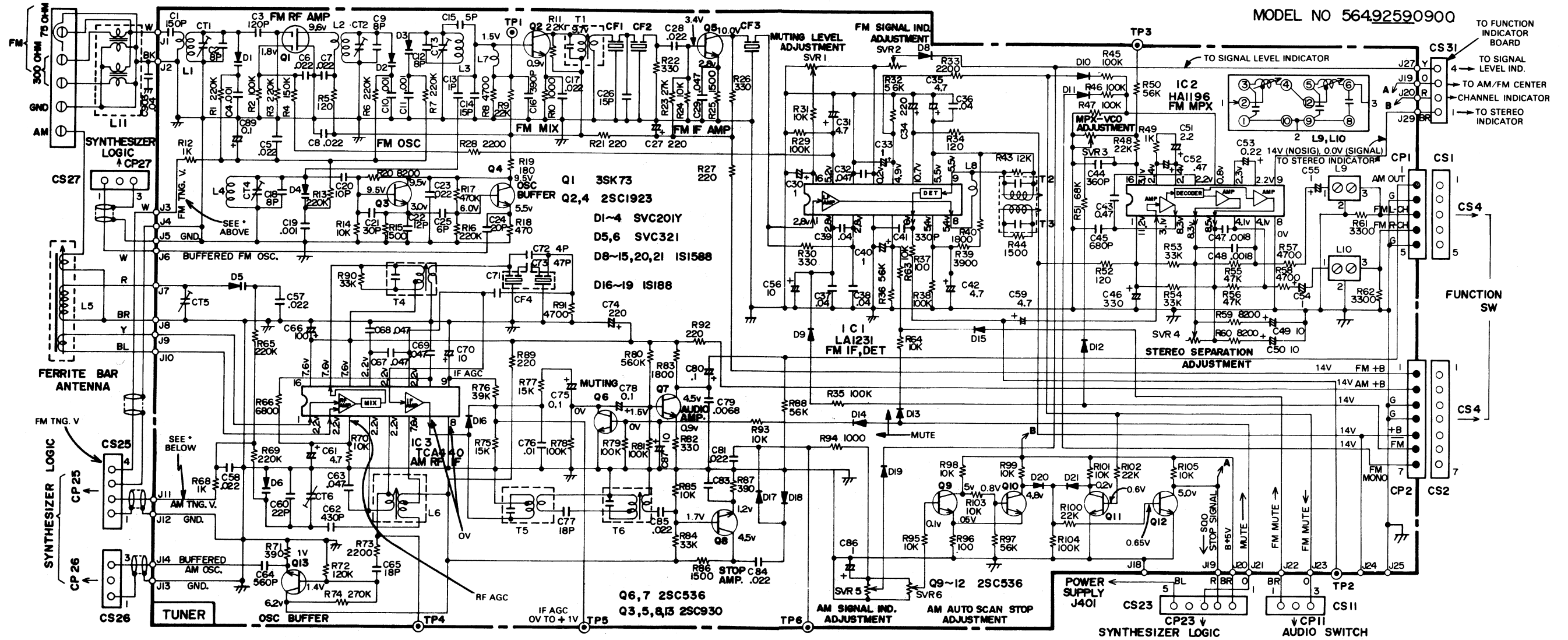

*1.5V @ 520KHz
9.6V @ 1620KHz

MODEL No. 564.92590900
TUNER

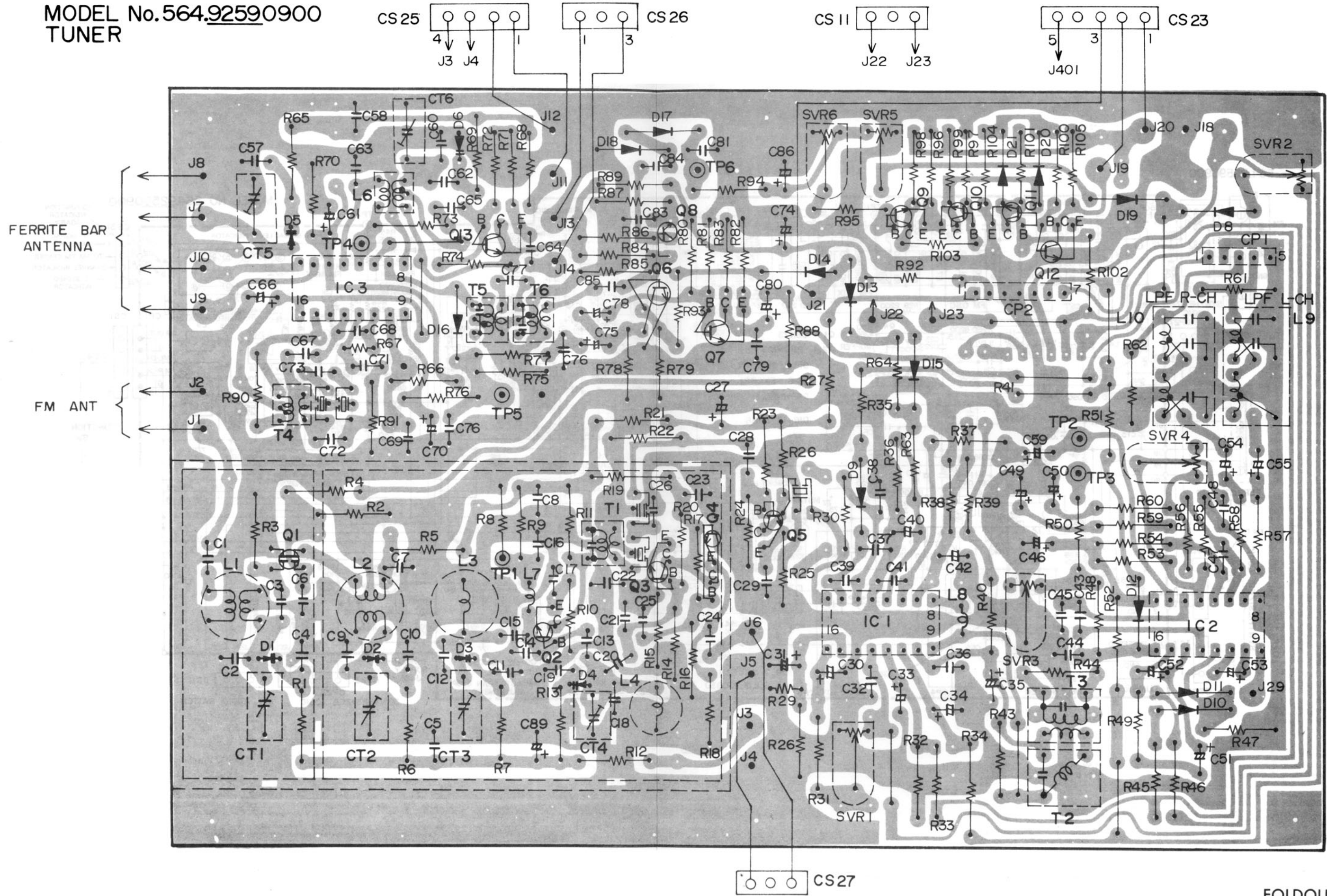

FOLDOUT

FERRITE BAR ANTENNA

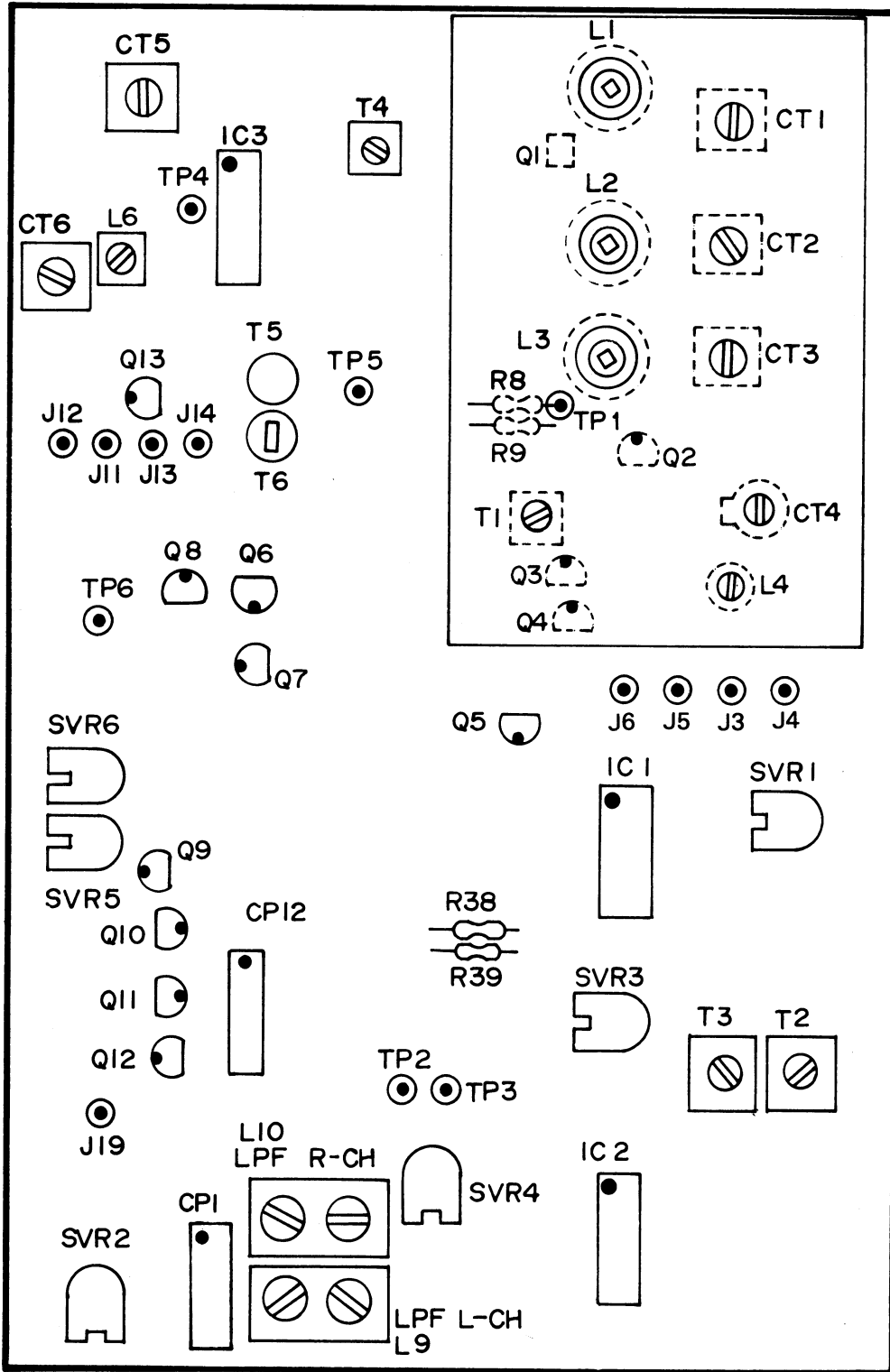
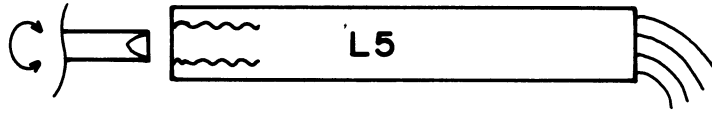

NOTE

- INDICATES PIN 1 ON IC AND CONNECTOR SYMBOLS, COLLECTOR ON TRANSISTOR SYMBOL.

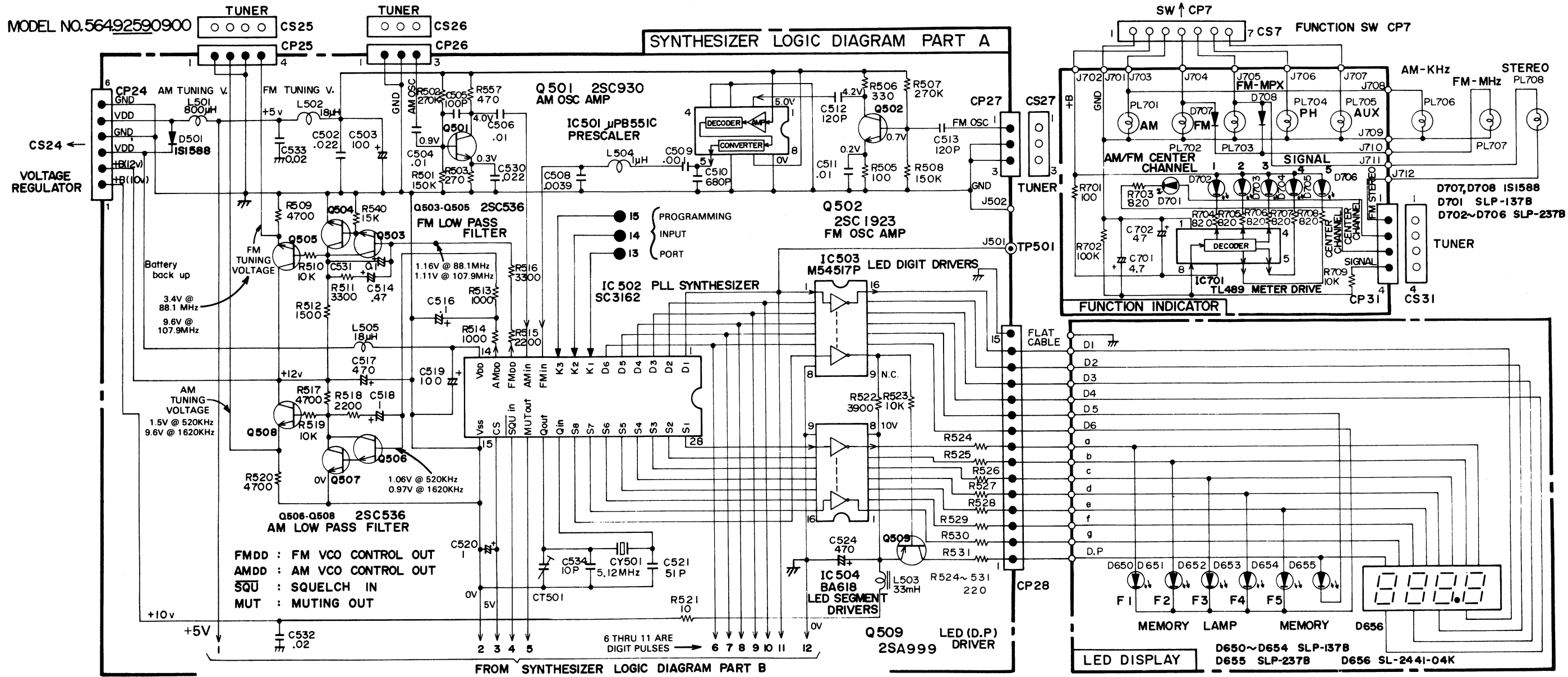

MODEL NO. 564.92590900

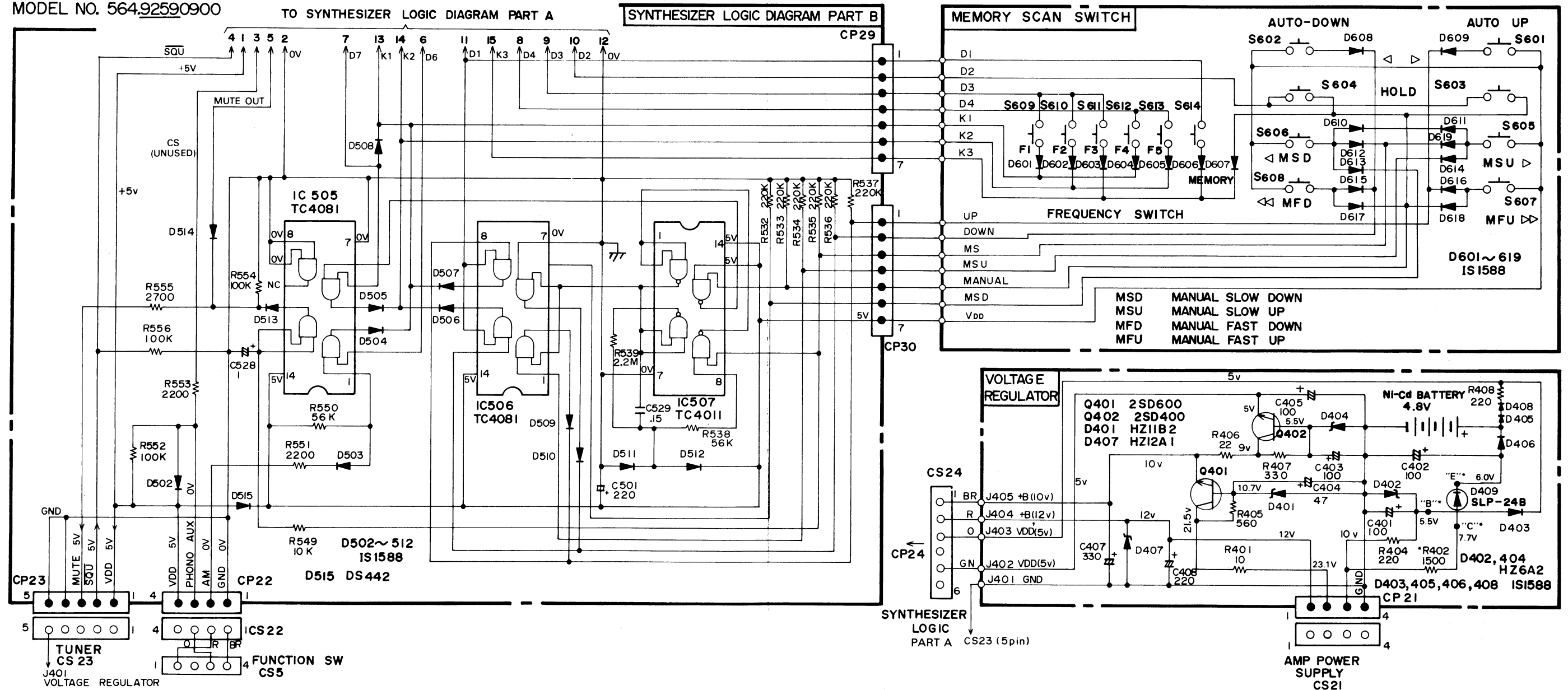

C, *E,* AND *B* REFER TO COLLECTOR, EMITTER, AND BASE OF Q403. IN EARLIER VERSIONS, Q403 WAS USED INSTEAD OF D409, AND R402 WAS 1800 OHMS, NOT 1500.

FOLDOUT

MODEL No. 564.9259 0900

SYNTHESIZER LOGIC P.C.BOARD
BOTTOM VIEW

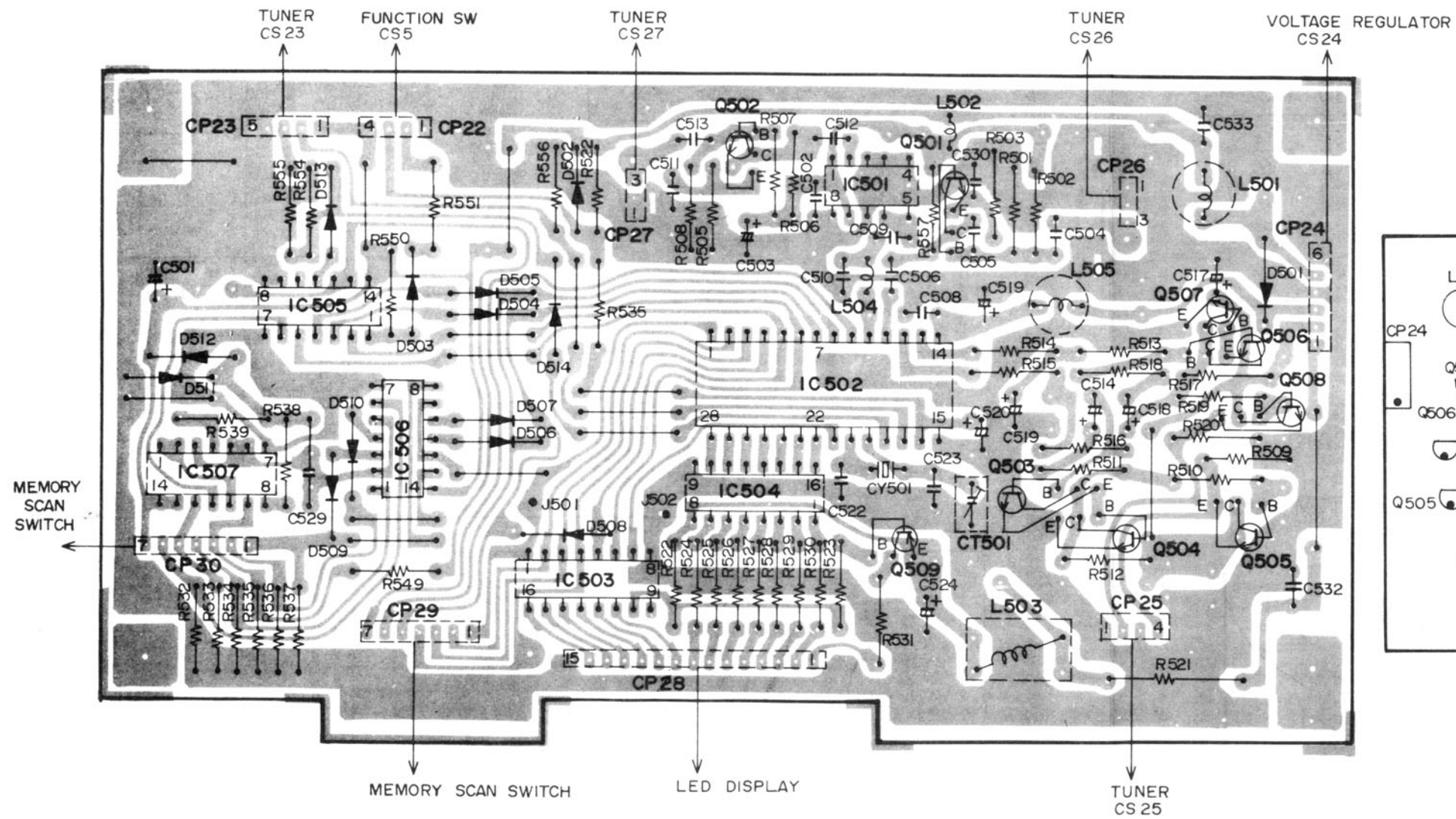

TOP VIEW

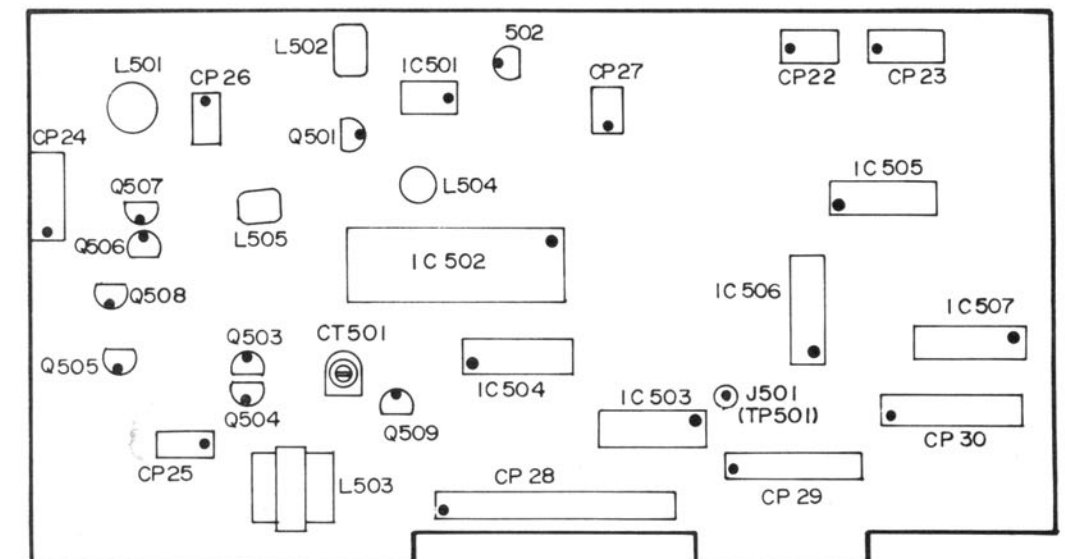

NOTE

● INDICATES PIN 1 ON IC AND CONNECTOR SYMBOLS, COLLECTOR ON TRANSISTOR SYMBOL.

MODEL No. 564.92590900

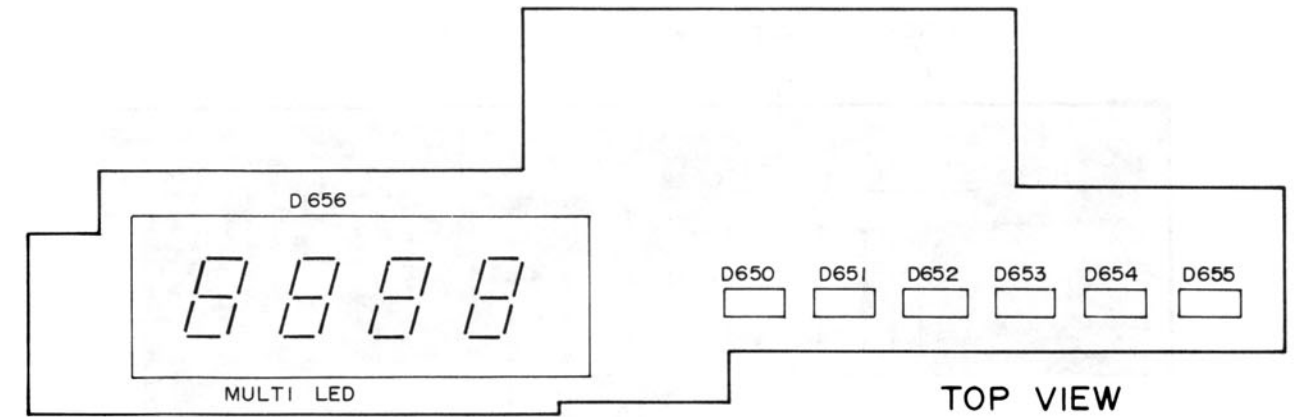
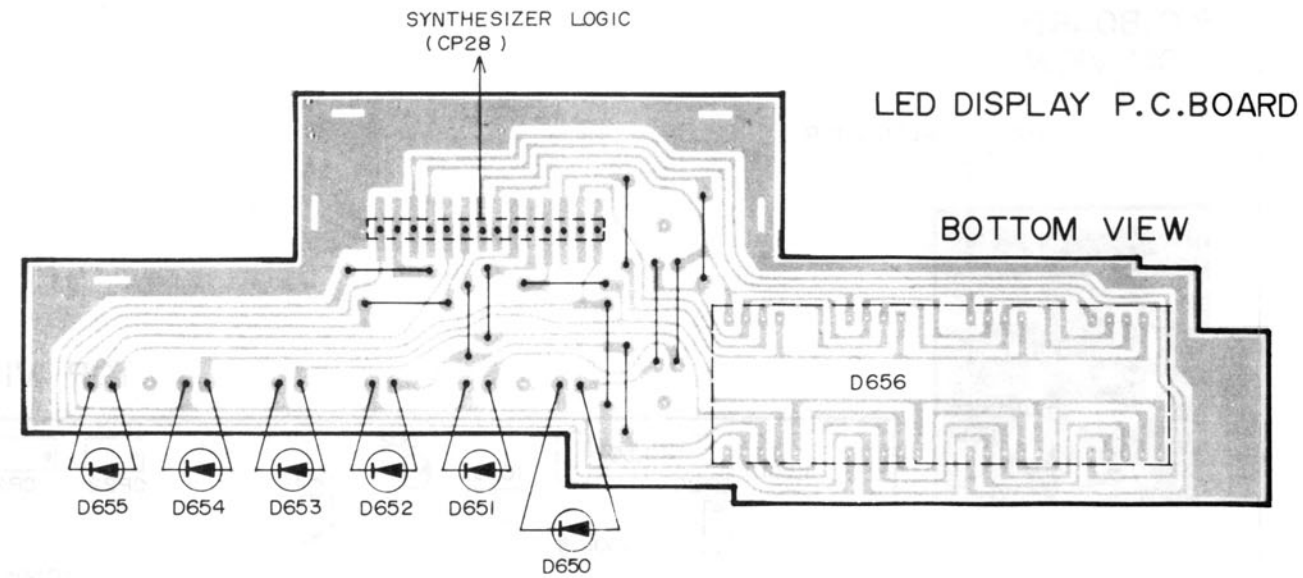

NOTE

● INDICATES PIN1 ON IC AND CONNECTOR SYMBOL, COLLECTOR ON TRANSISTOR SYMBOL.

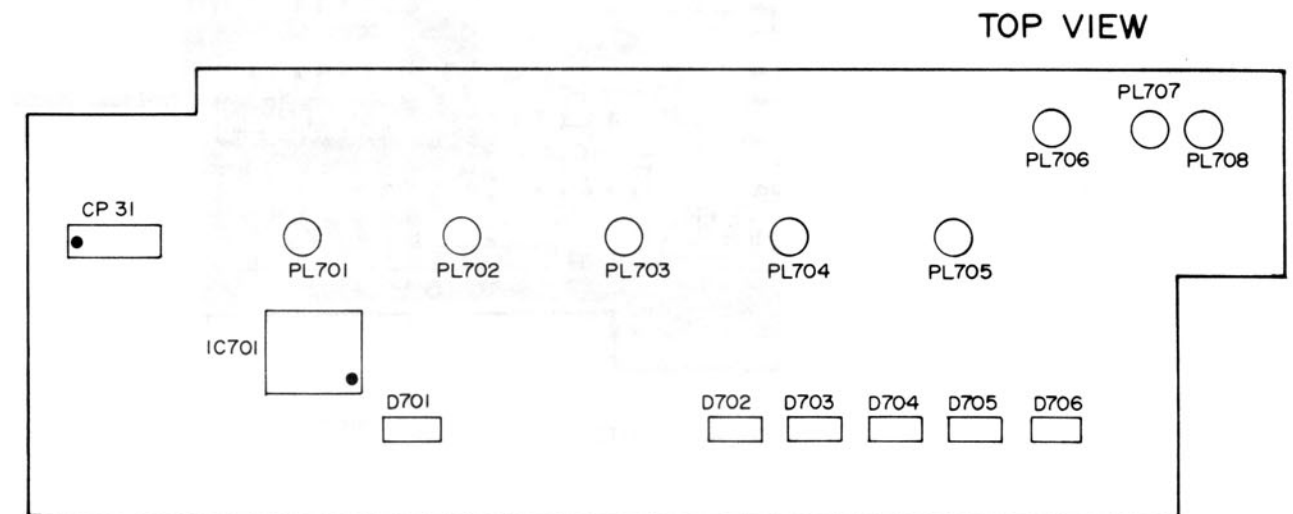
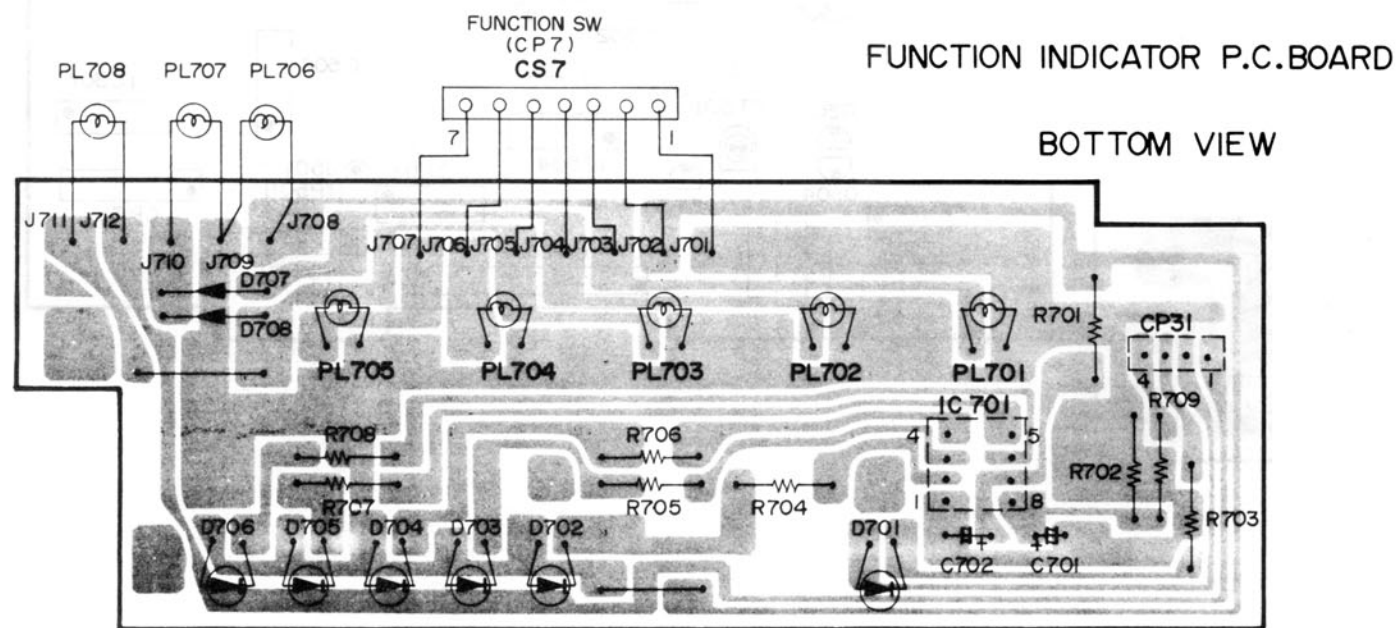

FOLDOUT

MODEL NO. 564.92590900

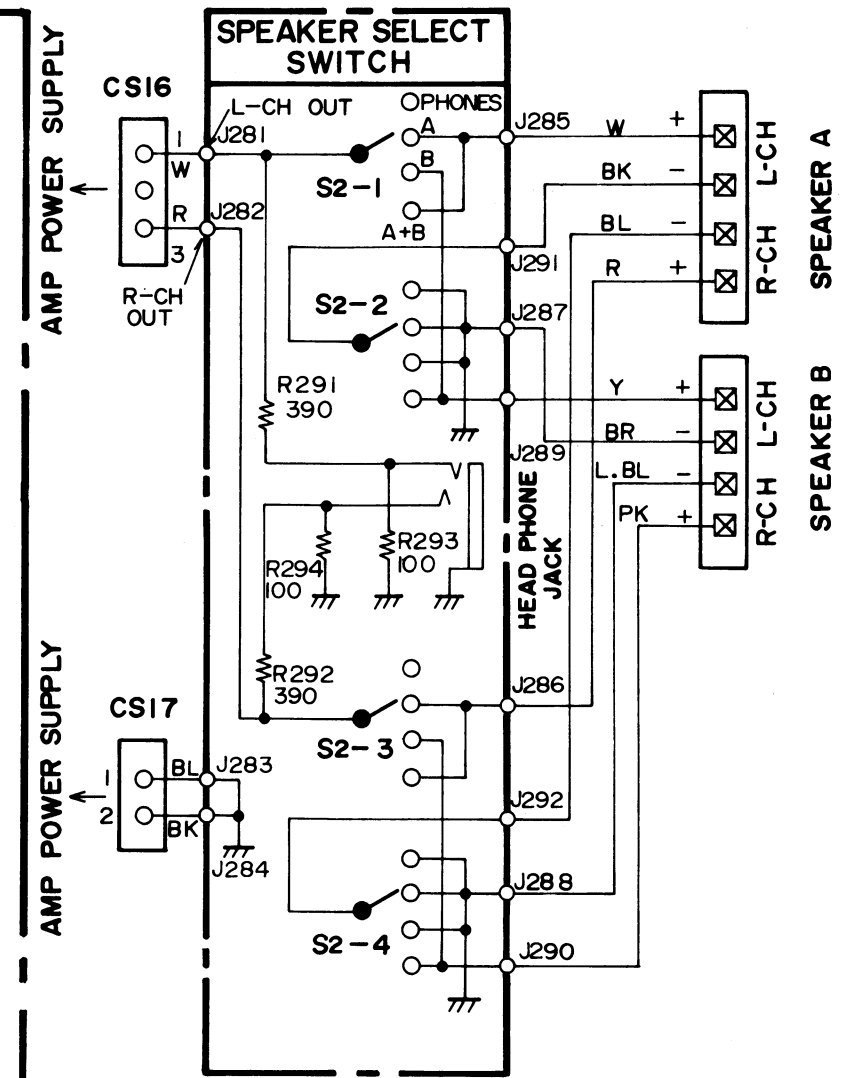
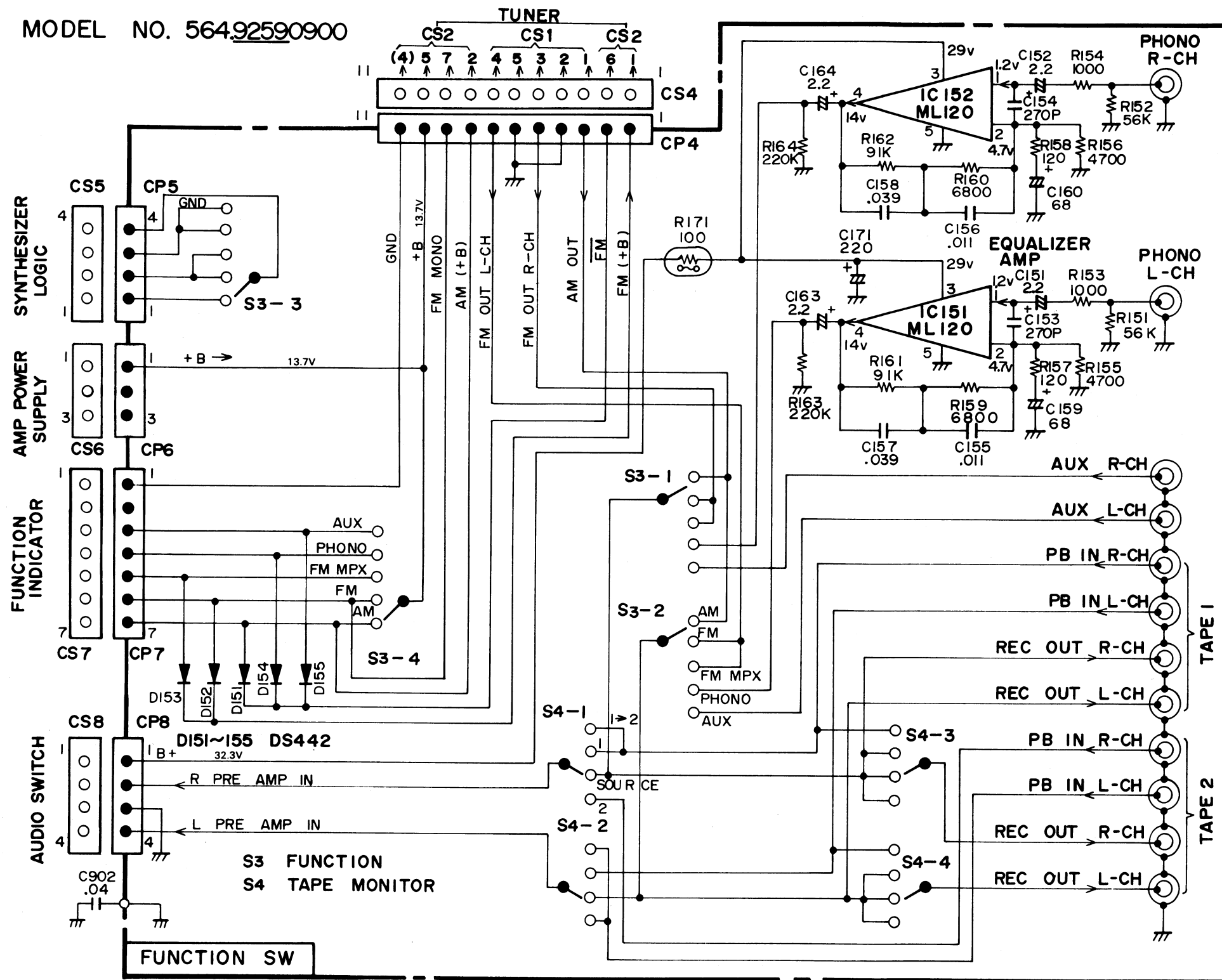

- NOTES**
1. ALL RESISTANCES ARE 1/4W, UNLESS NOTED OTHERWISE. VALUES ARE IN OHMS. ($\kappa=10^3, M=10^6$)
 2. ALL CAPACITOR VALUES ARE IN μF UNLESS OTHERWISE NOTED $P=10^{-6}\mu F$. (mm Fd)
 3. VOLTAGE READINGS TO COMMON GROUND ARE MEASURED WITH V.T.V.M. UNDER NO SIGNAL.

MODEL No. 564.9259 0900

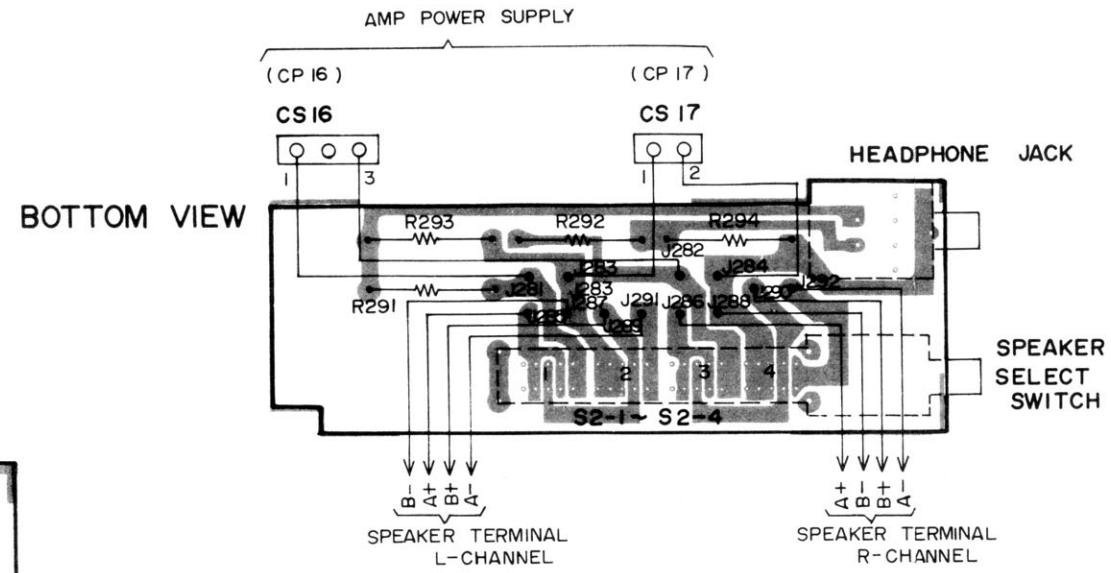

SPEAKER SELECT SWITCH P.C.BOARD

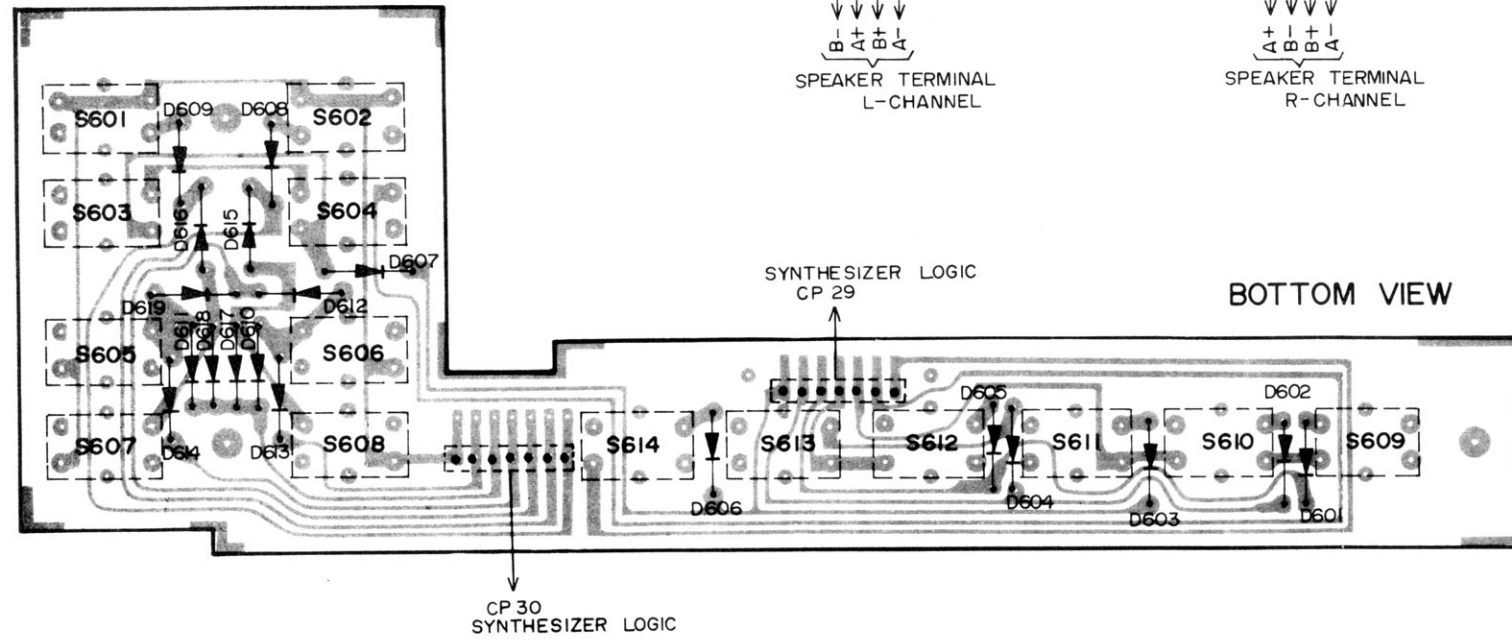
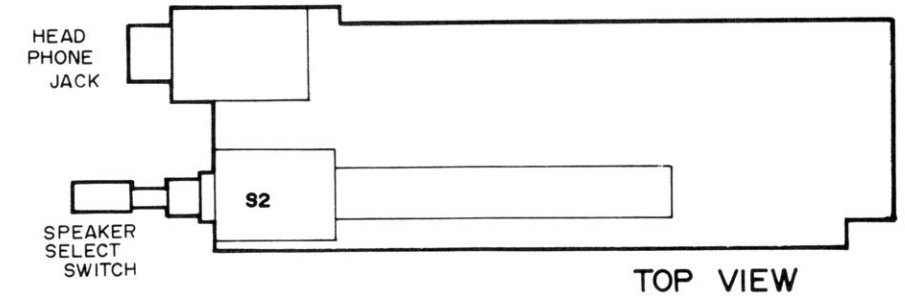

MEMORY & SCAN SWITCH P.C.BOARD

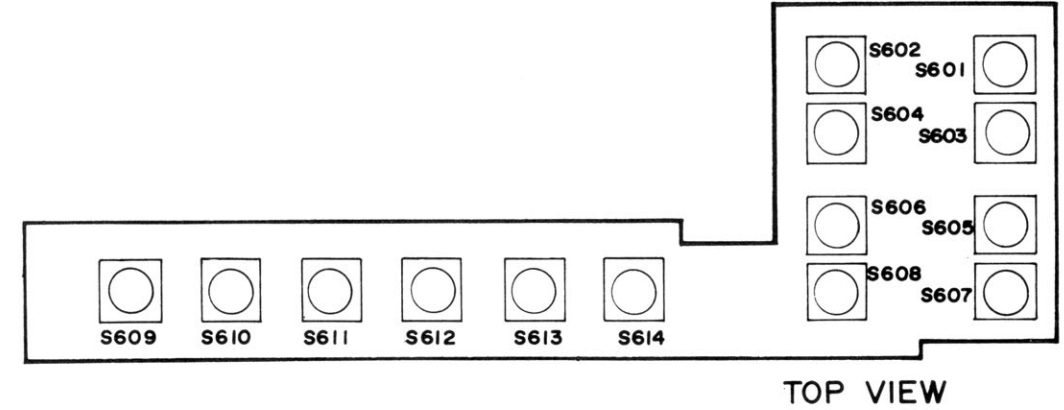

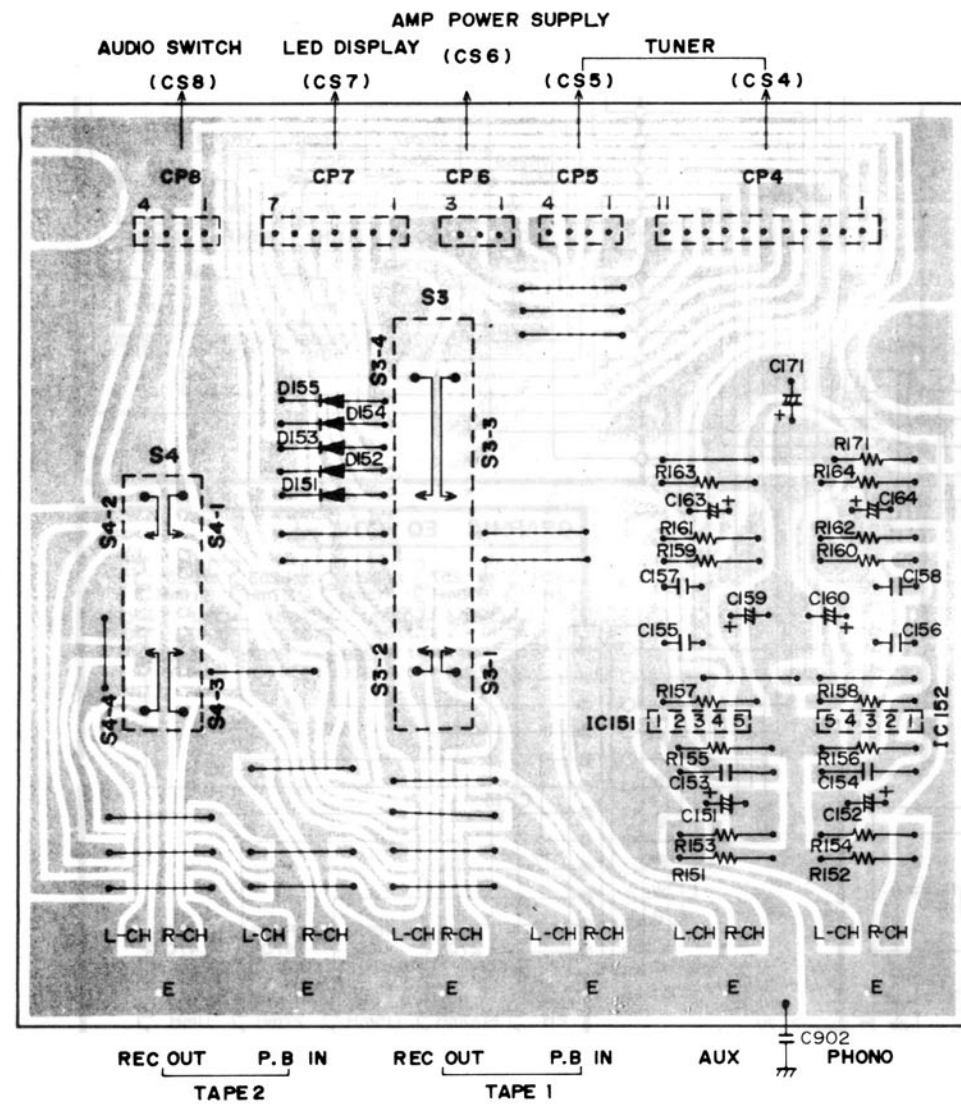

BOTTOM VIEW

FUNCTION SW P.C.BOARD

TOP VIEW

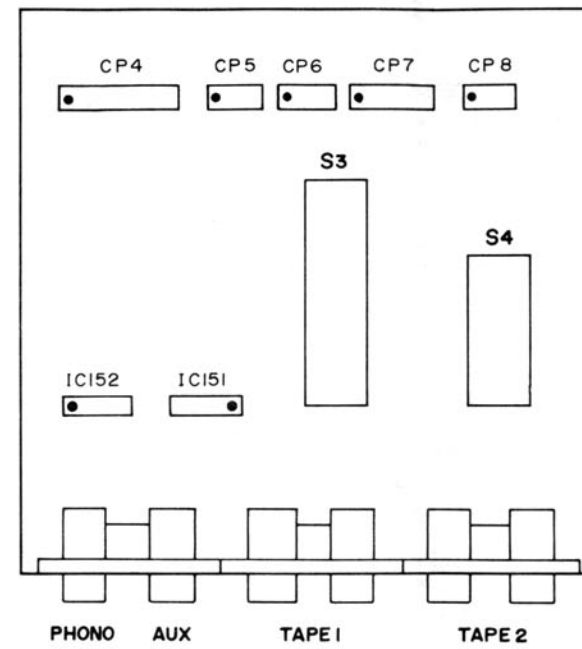

NOTE
 ● INDICATES PIN 1 ON IC AND CONNECTOR SYMBOLS, COLLECTOR ON TRANSISTOR SYMBOL.

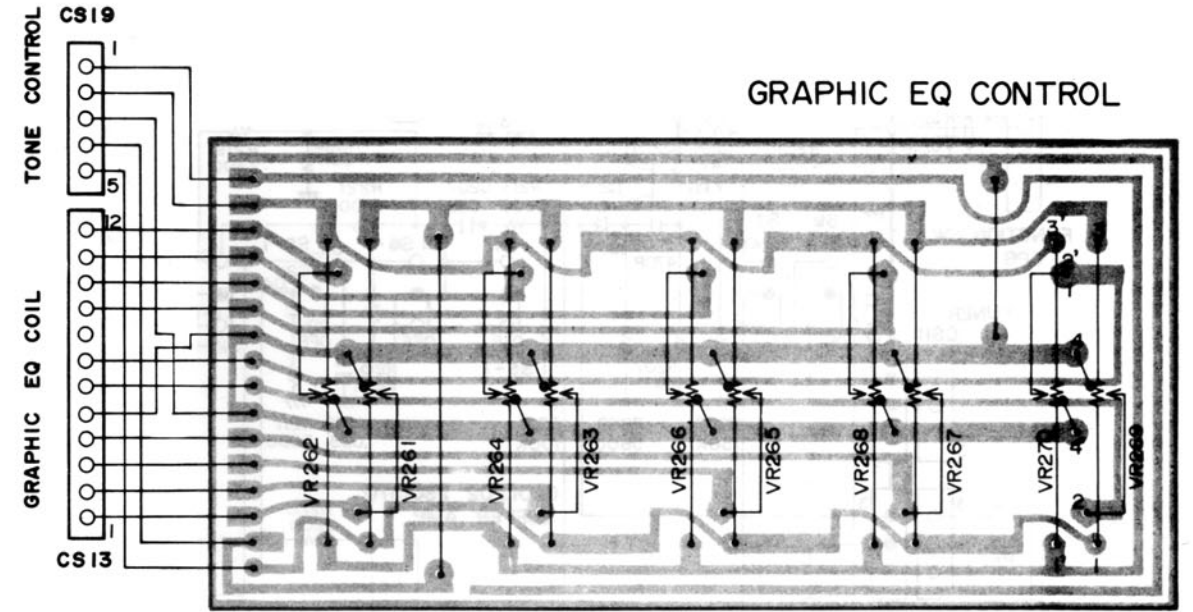

BOTTOM VIEW

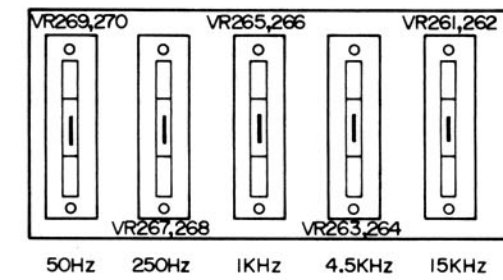

TOP VIEW

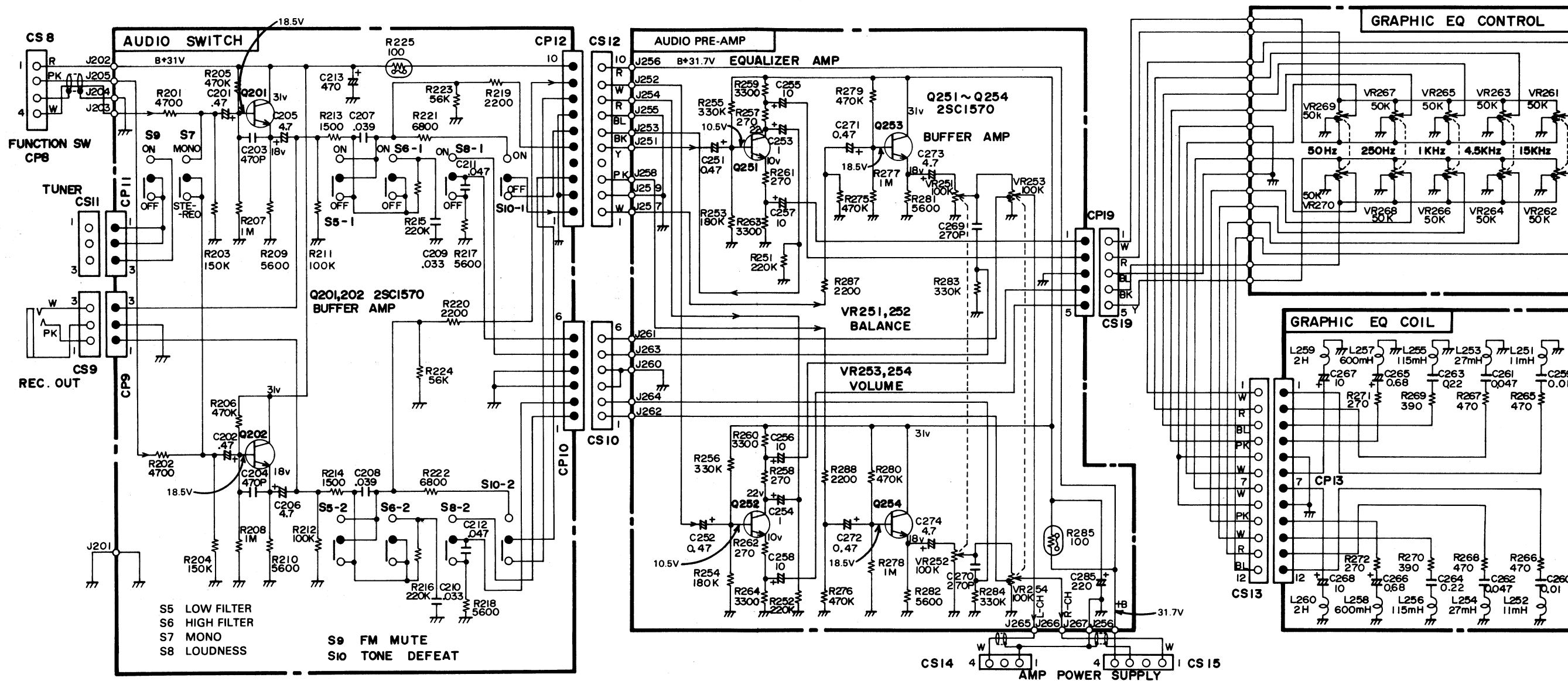

FOLDOUT

MODEL NO. 564.92590900

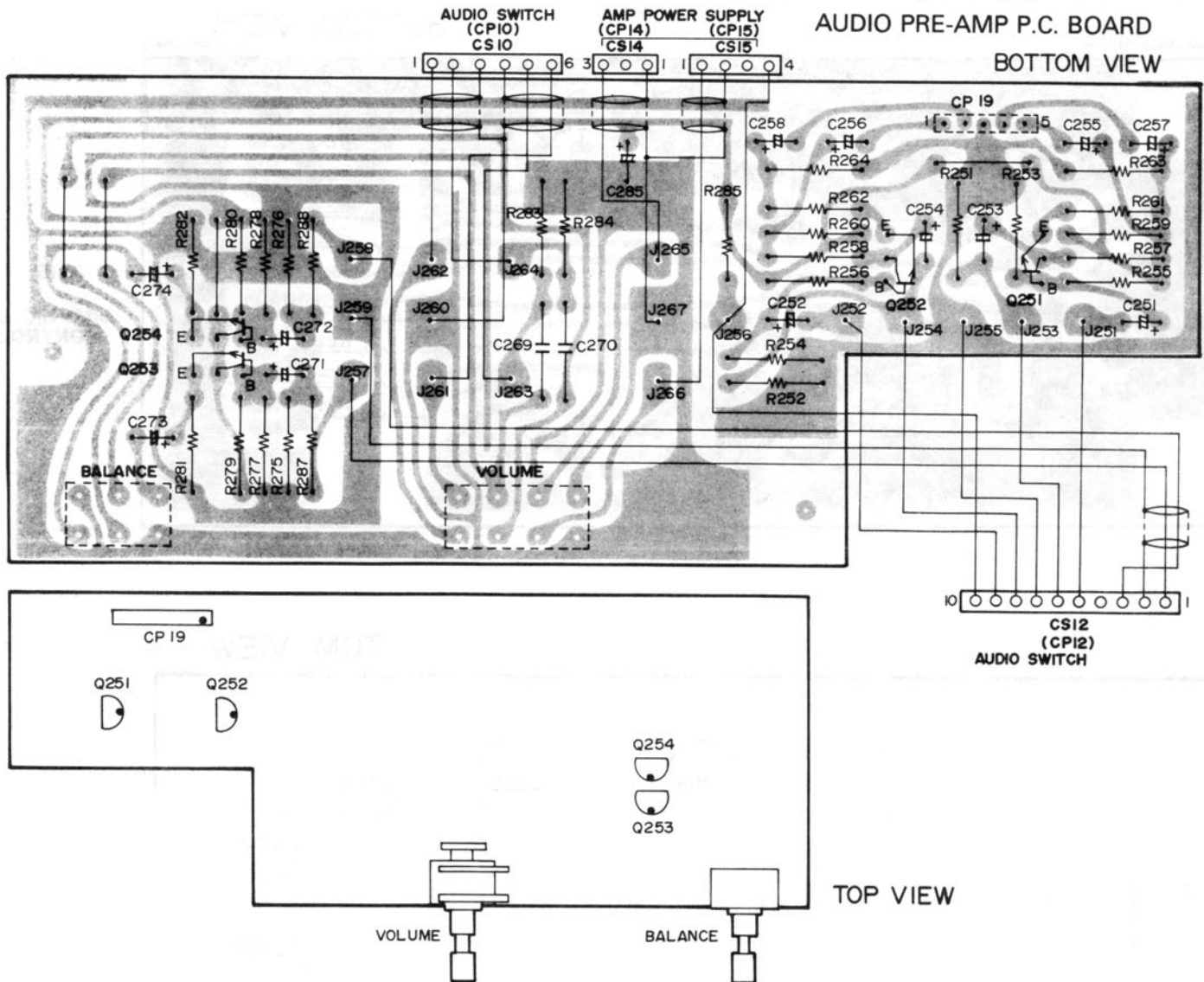

GRAPHIC EQ COIL P.C.BOARD

BOTTOM VIEW

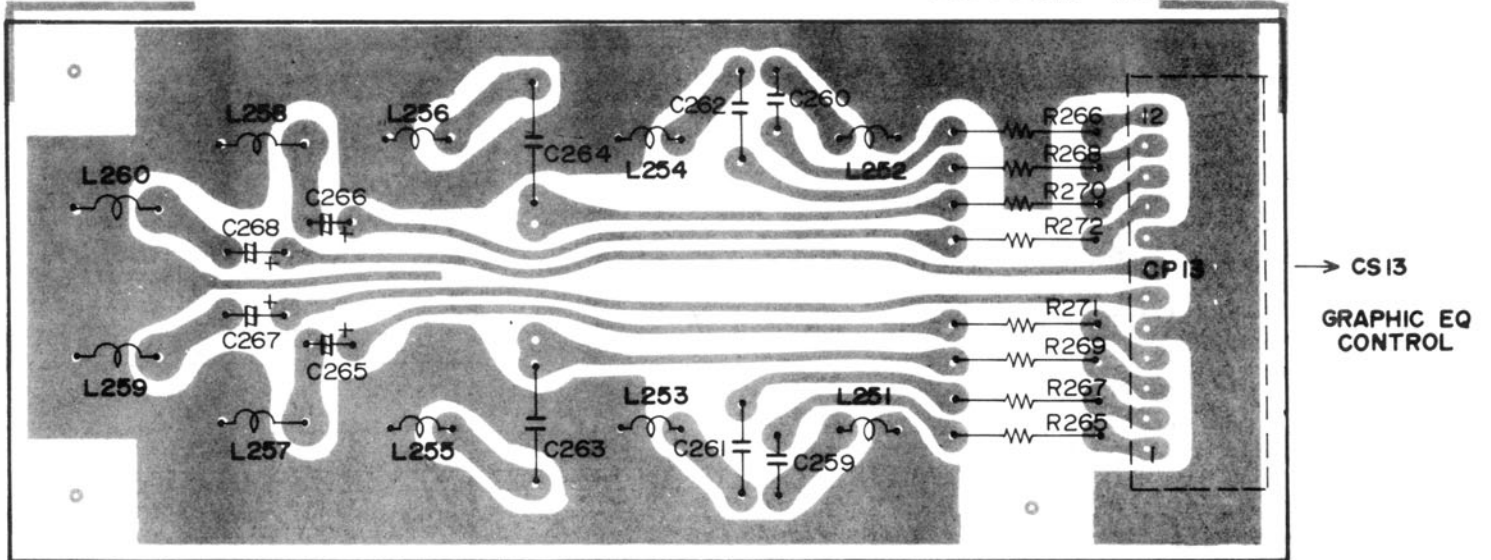

TOM VIEW

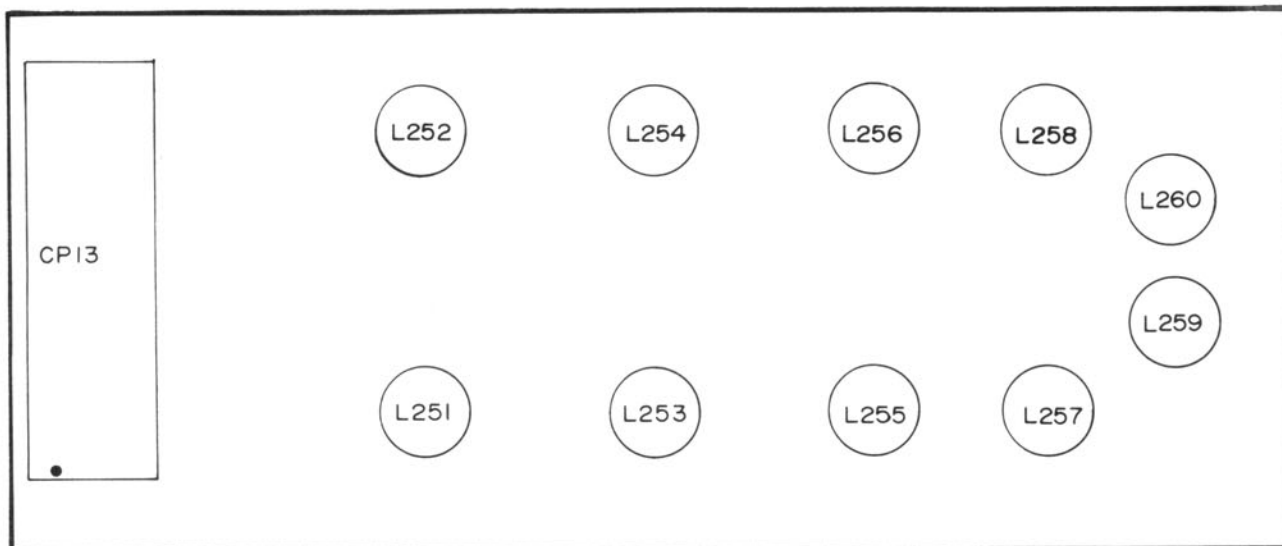

MODEL No. 564.92590900

VOLTAGE REGULATOR P.C.BOARD
BOTTOM VIEW

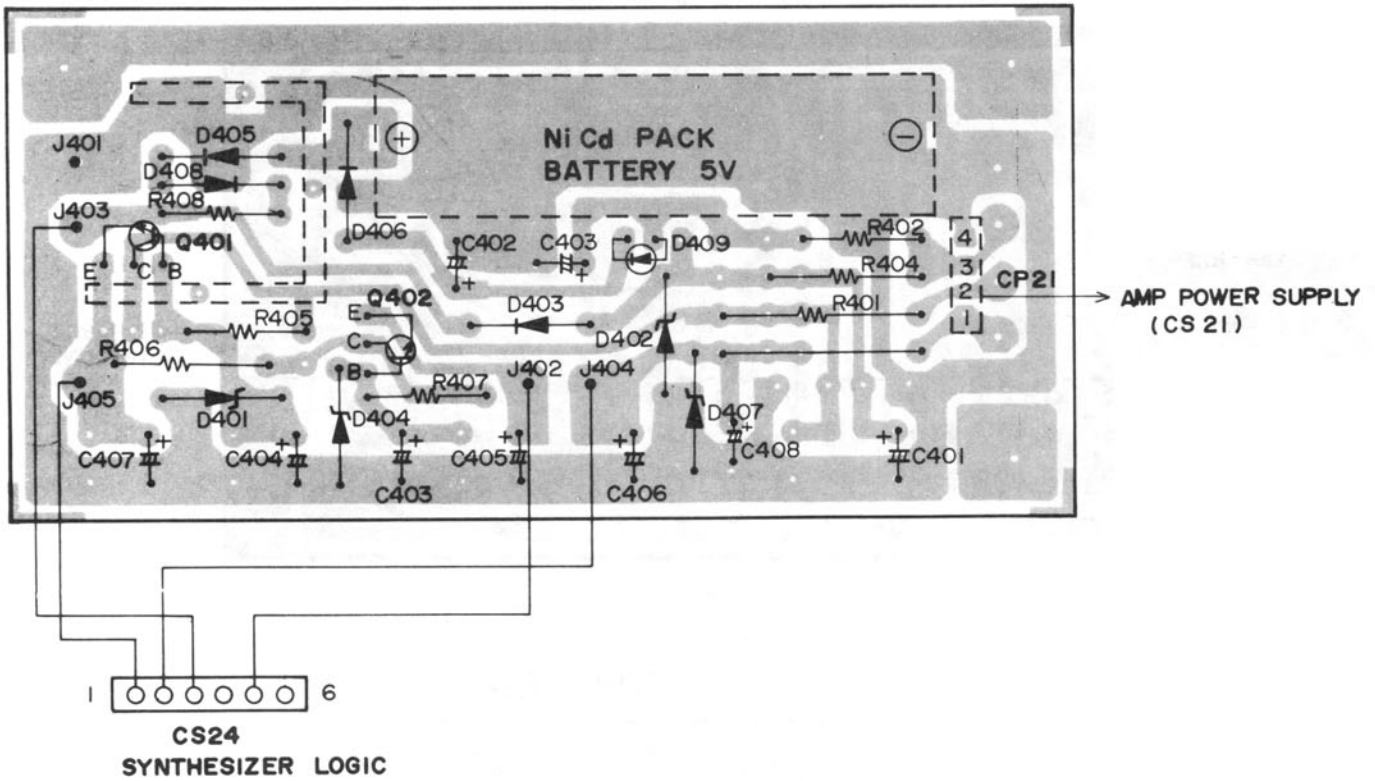

TOP VIEW

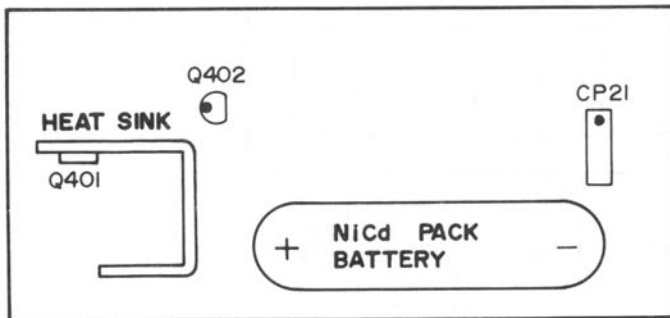

NOTE

- INDICATES PIN 1 ON IC AND CONNECTOR SYMBOLS, COLLECTOR ON TRANSISTOR SYMBOL.

AUDIO SWITCH P.C. BOARD BOTTOM VIEW

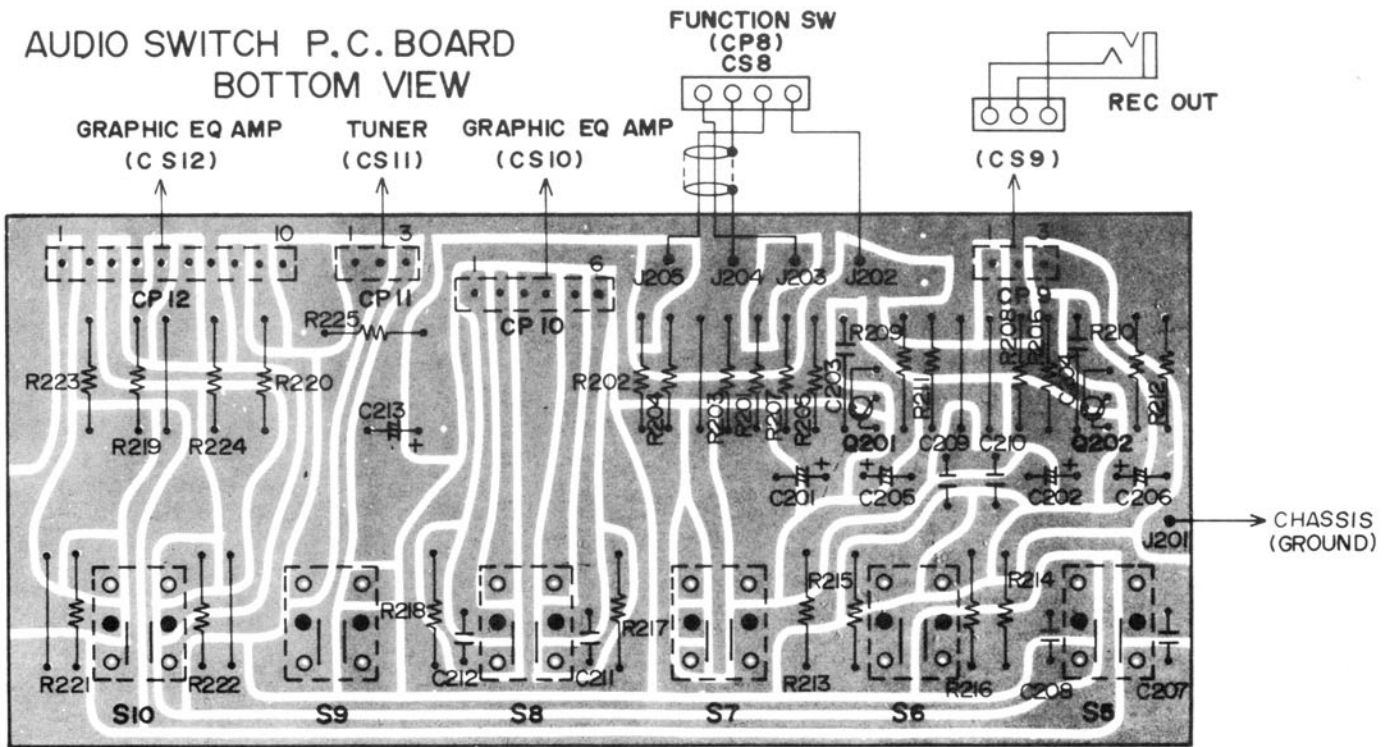

TOP VIEW

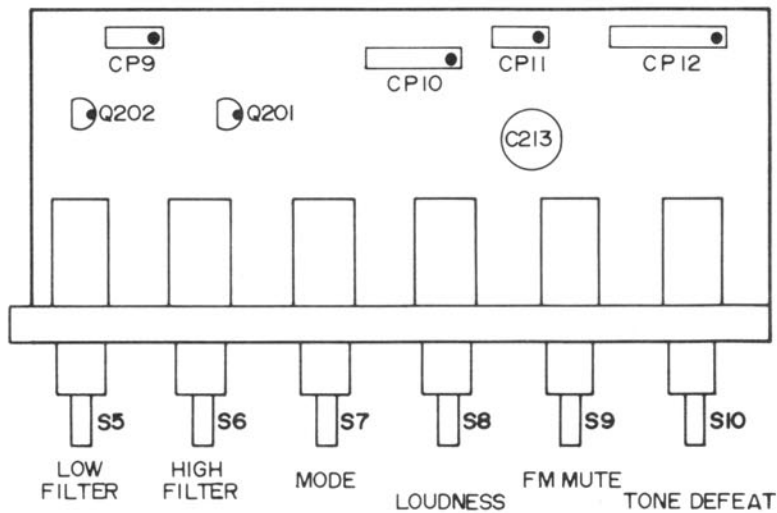

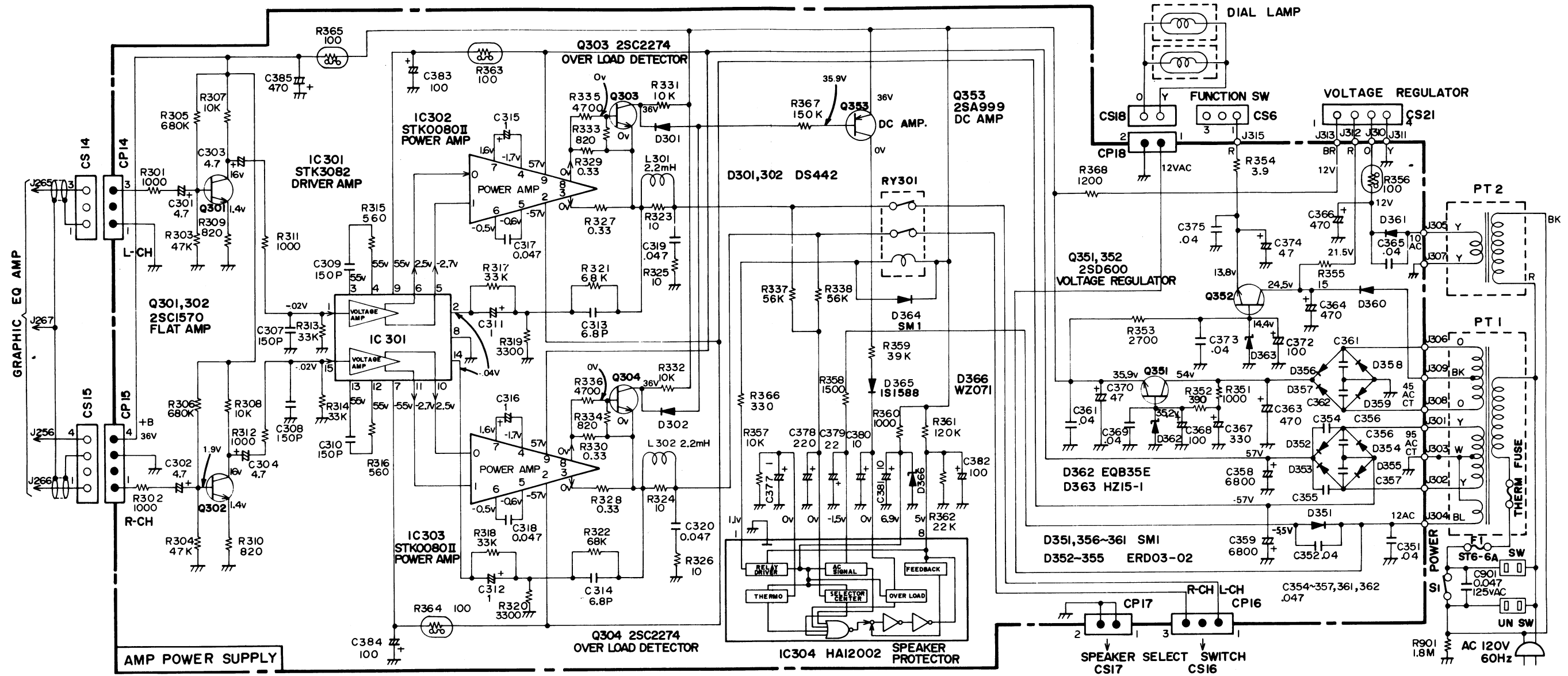

MODEL No.564.92590900

AMP POWER SUPPLY P.C.BOARD

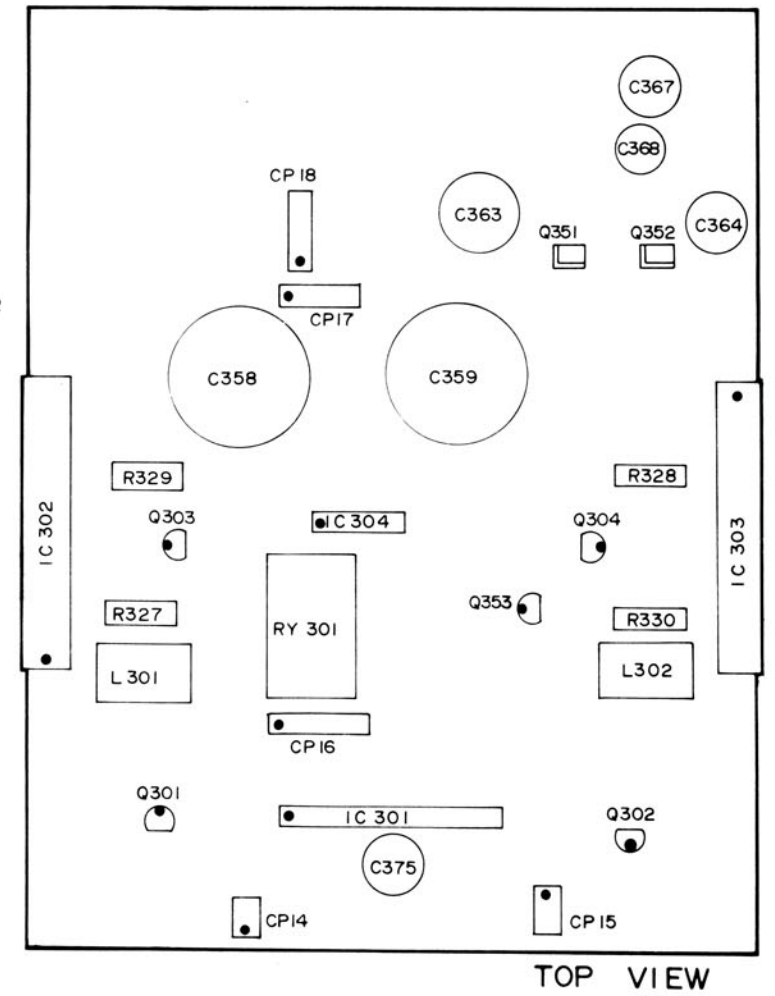
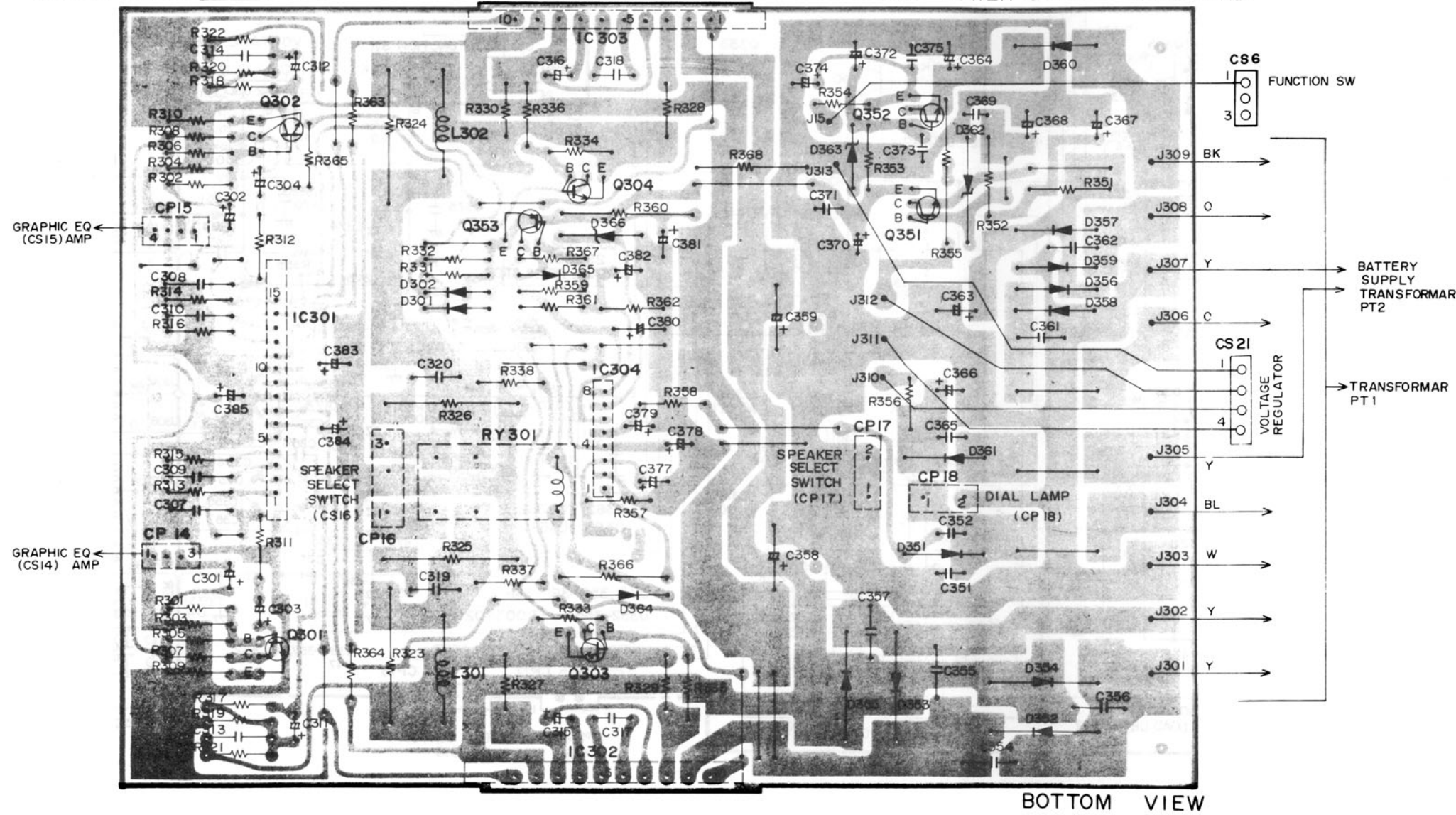

NOTES

- INDICATES PIN 1 ON IC AND CONNECTOR SYMBOLS, COLLECTOR ON TRANSISTOR SYMBOL.

MODEL No. 564.92590900
PARTS LAYOUT TOP VIEW

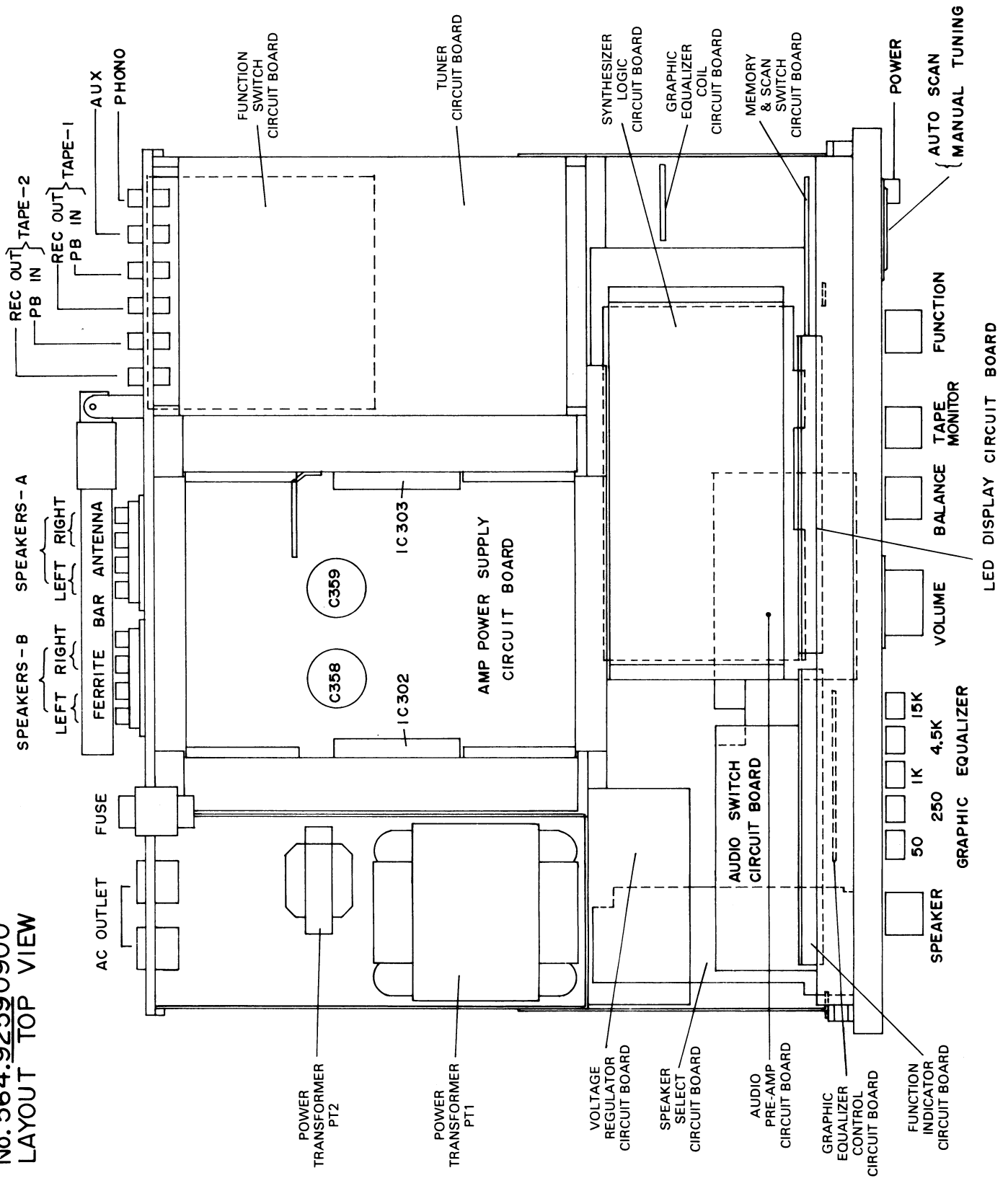

MODEL 564.92590900

ALIGNMENT PROCEDURES

AM ALIGNMENT

INSTRUMENTS AM IF Sweep Generator, AM RF Signal Generator, VTVM, and Oscilloscope.

NOTE Place the controls and switches in the following positions unless otherwise instructed.

Function—AM position
 Balance—0 (center)
 Tone defeat—ON (inner) position

Volume—0 (minimum)

Tape Monitor—SOURCE

FM Mute, Loudness, Mono, High and Low Filters—OFF (outer) position, Speakers—A position where a pair of test speakers are connected. Keep the input signal level as low as possible to avoid the AVC action.

AM IF ALIGNMENT

Step	Generator Connection	Input Signal	Test Equipment Connection	Adjustment
1.	Sweep Generator to TP4 Thru a 0.02 mfd ceramic capacitor	450 kHz	Oscilloscope to TP5	Tune T4 for highest and most symmetrical IF response. See Figure 1.
2.			Oscilloscope to TP6	Tune T6 for highest and most symmetrical IF response. See Figure 1.
3. Repeat above steps until no further change is noted in any of the AM IF adjustment.				

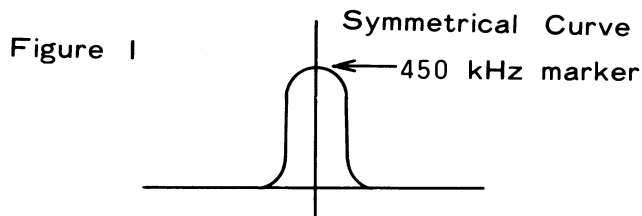

CRYSTAL OSCILLATOR ADJUSTMENT

1. Set the FREQUENCY display to 1,000kHz by manual tuning.
2. Connect frequency counter across J14 and J13 (ground).
3. Adjust CT501 for 1450.0kHz reading on the counter.

AM RF ALIGNMENT

Step	Generator Connection	Input Signal	Receiver Dial Setting	Test Equipment Connection	Adjustment
1.	No Connection	No Signal	520 kHz	Connect VTVM across J11 and ground	Adjust L6 for more than 1.15V DC.
2.		No Signal	1,620 kHz		Adjust CT6 for more than 9.3V DC.
3.	Loop Ant.	600 kHz, 1,000Hz, 30% mod. 300 μ V/m	600 kHz	Connect VTVM's in parallel with the test speakers. Adjust VOLUME Control for 2V reading on the VTVM's.	Tune L5 for max output.
4.		1,400 kHz, 1,000 Hz, 30% mod. 300 μ V/m	1,400 kHz		Tune CT5 for max output.
5. Repeat above steps until no further change is noted in any of the AM RF adjustment.					

AM SIGNAL STRENGTH INDICATOR ADJUSTMENT

Step	Generator Connection	Input Signal	Receiver Dial Setting	Adjustment
1.	Loop Ant.	1,000 kHz, 1,000 Hz, 30% mod. 5 mV/ m	1,000 kHz	Adjust SVR5 for 4 lighted LED's in the Signal Strength Indicator.

AM SIGNAL SCAN LEVEL ADJUSTMENT

Step	Generator Connection	Input Signal	Receiver Dial Setting	Test Equipment Connection	Adjustment
1.	Loop Ant.	1,000 kHz, 1,000 Hz, 30% mod. 1mV/ m	1,000 kHz	Connect VTVM across J19 and ground.	Adjust SVR6 for 4.5V~5.5V DC.

FM ALIGNMENT

INSTRUMENT FM IF Sweep Generator, Stereo Signal Generator, FM Generator, VTVM, and Oscilloscope.

NOTE Place the FUNCTION switch in the FM position.
Leave all other selectors and switches in the positions as under NOTE of AM ALIGNMENT unless otherwise instructed.

FM IF ALIGNMENT

Step	Generator Connection	Input Signal	Test Equipment Connection	Adjustment
1.	Sweep Generator to TPI	10.7MHz	Oscilloscope to TP2	Adjust T1, T2, and T3 for highest and most symmetrical "S" curve. See Figure 2.

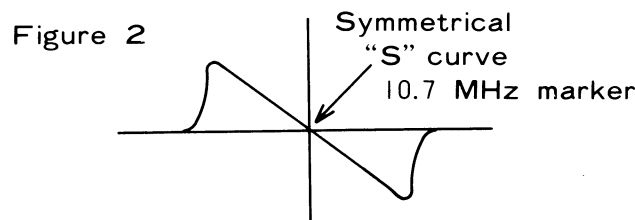

FM RF ALIGNMENT

Step	Generator Connection	Input Signal	Receiver Dial Setting	Test Equipment Connection	Adjustment
1.	No Connection	No Signal	88.1MHz	Connect VTVM across J3 and ground	Adjust L4 for more than 2.6V DC.
2.		No Signal	107.9MHz		Adjust CT4 for more than 9.3V DC.
3.	Dummy Antenna See Figure 3.	90.1 MHz 1000Hz 100% mod.	90.1 MHz	Connect VTVM's in parallel with the test speakers Adjust VOLUME Control for 2V readings on the VTVM's	Tune L1, L2, and L3 for maximum reading
4.		106.1 MHz 1000 Hz 100% mod.	106.1 MHz		Tune CT1, CT2, and CT3 for maximum reading
5. Repeat above steps until no further change is noted in any of the AM RF adjustment.					

Figure 3

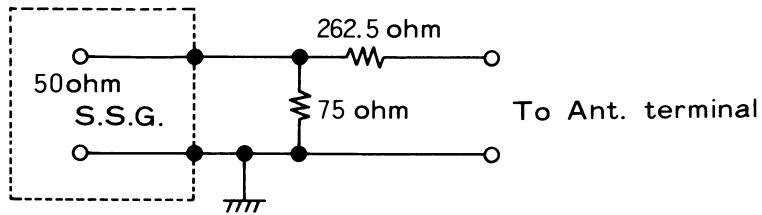

FM SIGNAL STRENGTH INDICATOR ADJUSTMENT

Step	Generator Connection	Input Signal	Receiver Dial Setting	Test Equipment Connection	Adjustment
1.	Dummy Antenna See Figure 3.	98.1 MHz, 1,000 Hz, 100% mod. 10 μ V	98.1 MHz		Adjust SVR2 for 1 lighted LED in the Signal Strength Indicator

FM. MUTING LEVEL ADJUSTMENT

Step	Generator Connection	Input Signal	Receiver Dial Setting	Test Equipment Connection	Adjustment
1.	Dummy Antenna See Figure 3.	98.1 MHz, 1,000 Hz, 100% mod. 10 μ V	98.1 MHz	Connect VTVM across J19 and ground	Adjust SVR1 for more than 4.5V DC.

FM MPX ADJUSTMENT (See Figure 4.)

NOTE: The FM IF Alignment must be completed before attempting this FM MPX adjustment. Poor IF alignment will result in poor FM MPX adjustment.

Place the FUNCTION selector switch in FM MPX position.

Step	Generator Connection	Input Signal	Stereo Signal Generator	Receiver Dial Setting	Test Equipment Connection	Adjustment
1.	No Connection	No Signal	No Signal	Any setting where no external signal received. Place MUTE Switch On (inner) position if necessary.	Connect frequency Counter to TP3	Adjust SVR3 for 76 kHz on the counter.
2.	Thru dummy Ant. See Figure 3.	98.1 MHz 1mV	19kHz, 10% mod. 1kHz 90% mod. Right channel only	98.1 MHz	Connect VTVM's in parallel with the test speakers, or 8 ohm dummy loads.	Adjust VOLUME Control for 2V on the Right VTVM. Then adjust SVR 4 for minimum (less than 50mV) on the Left VTVM.
3.			19kHz, 10% mod. 1kHz 90% mod. Left channel only			Adjust VOLUME Control for 2V on the Left VTVM. Then adjust SVR 4 for minimum (less than 50mV) on the Right VTVM.
4. Repeat the Steps 2 and 3 until the minimum readings on the both channels are balanced.						

Figure 4

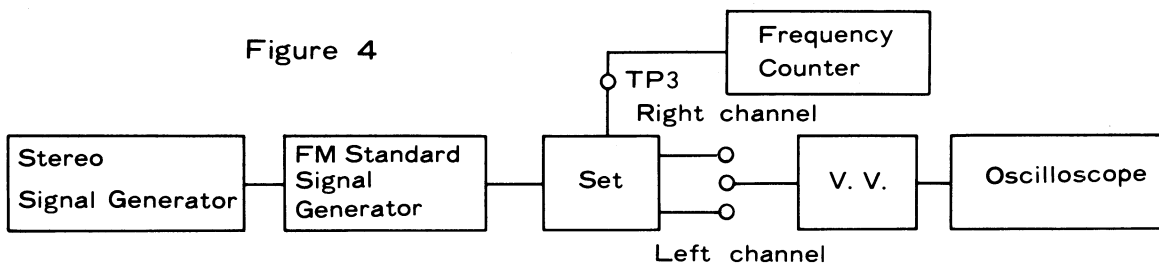

A. NO SOUND

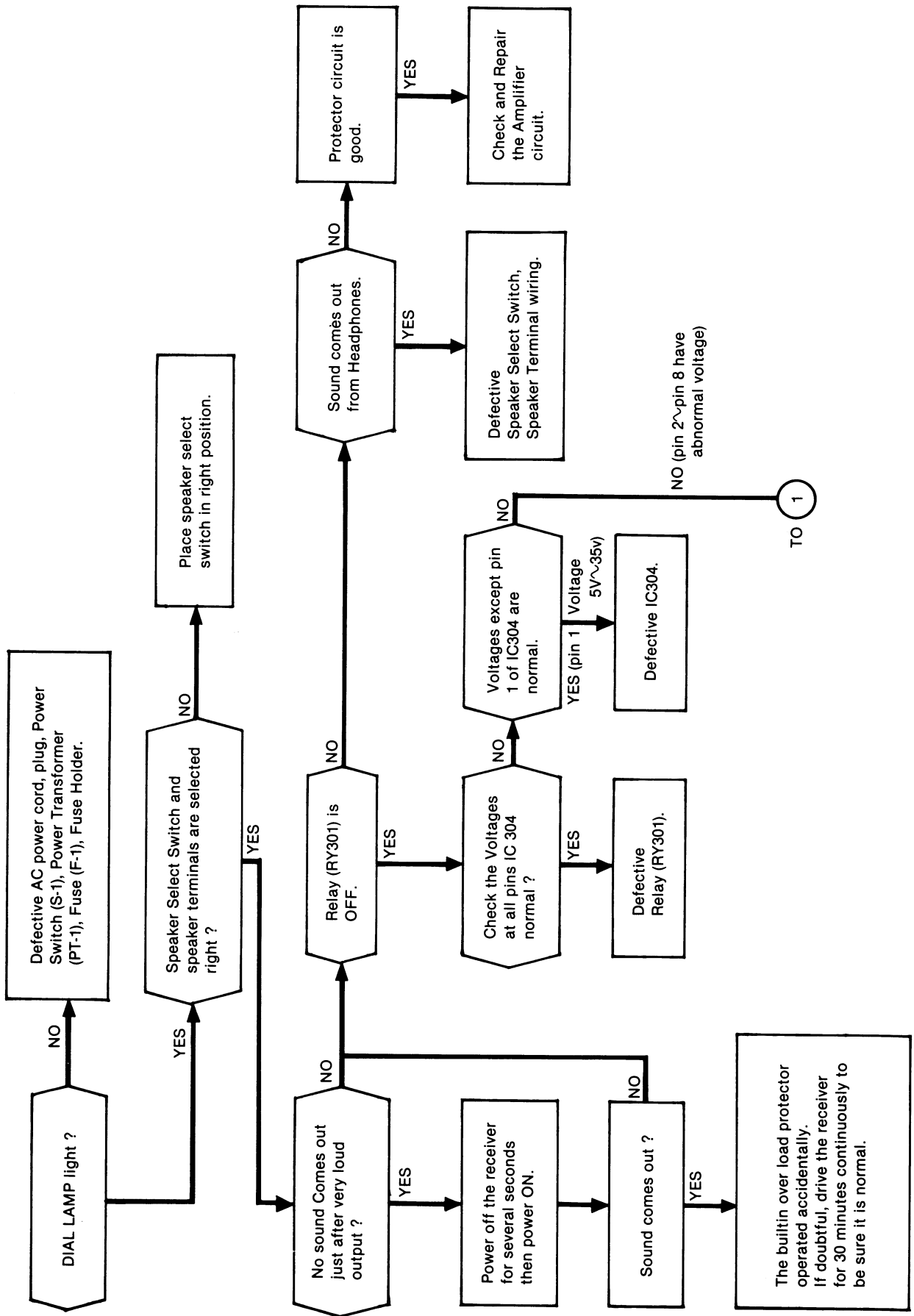

A. NO SOUND (continued)

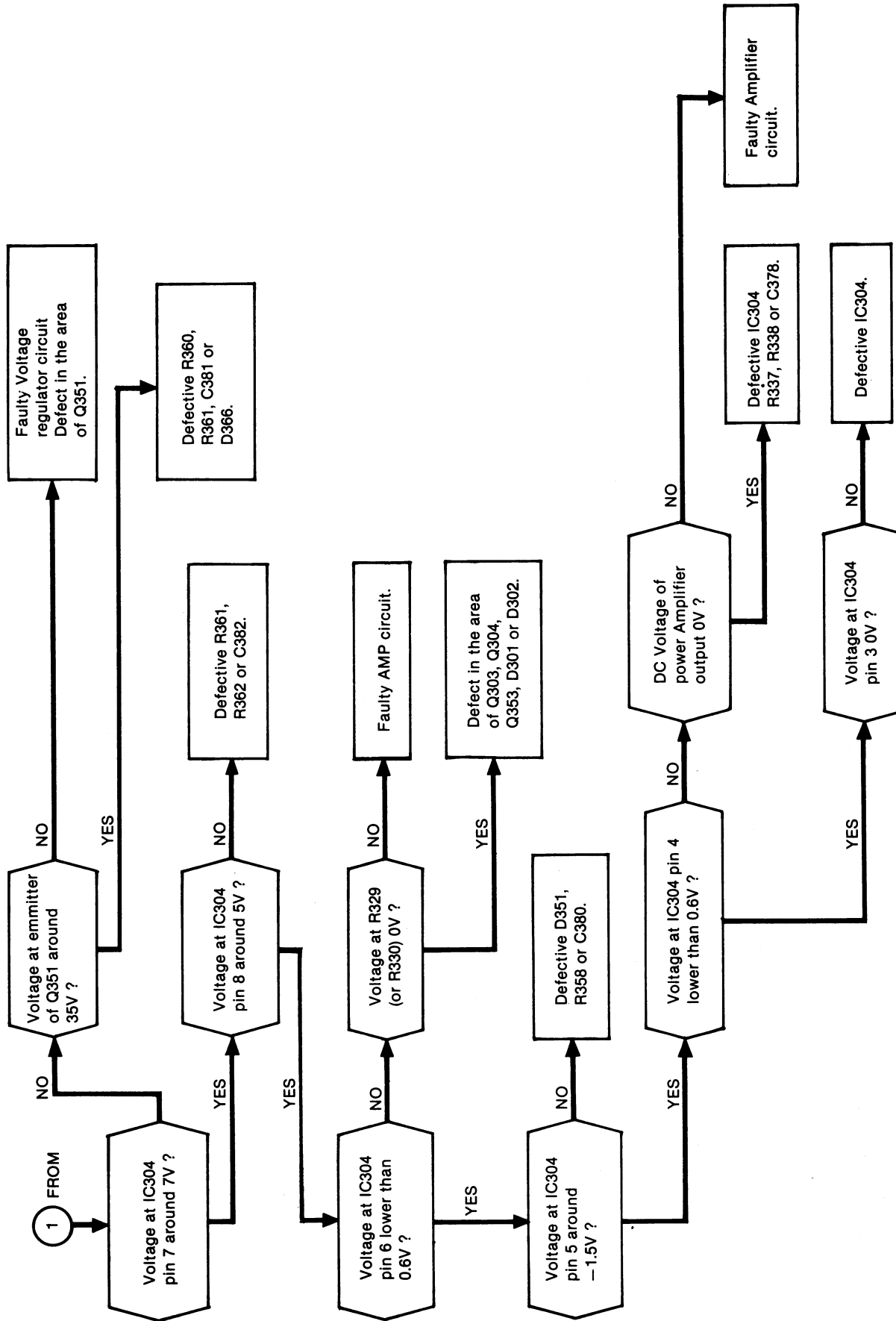

B. NO RADIO (AM and FM)
 (Follow chart C or D if
 either of AM or FM is
 good)

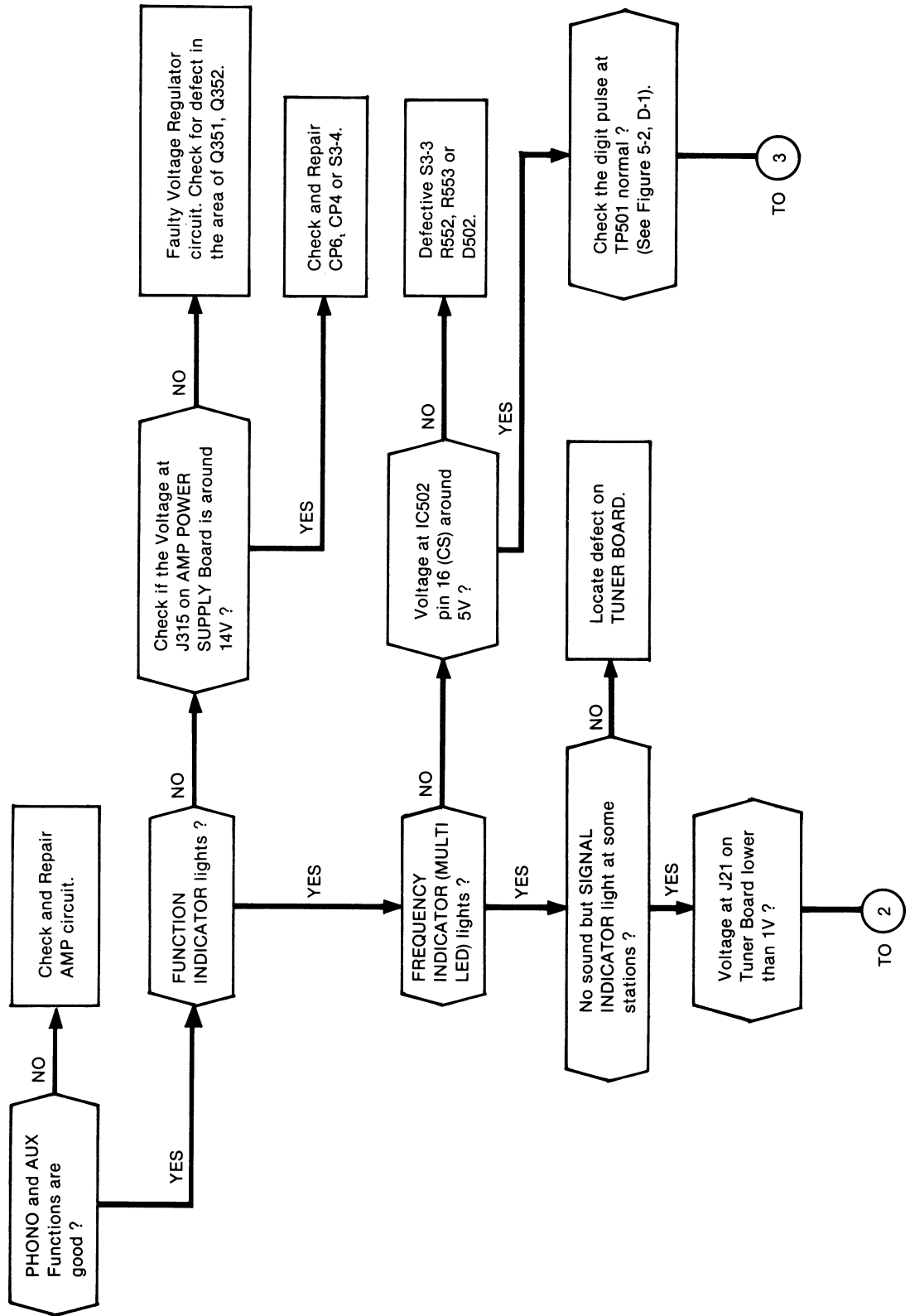

B. NO RADIO (AM and FM)
(continued)

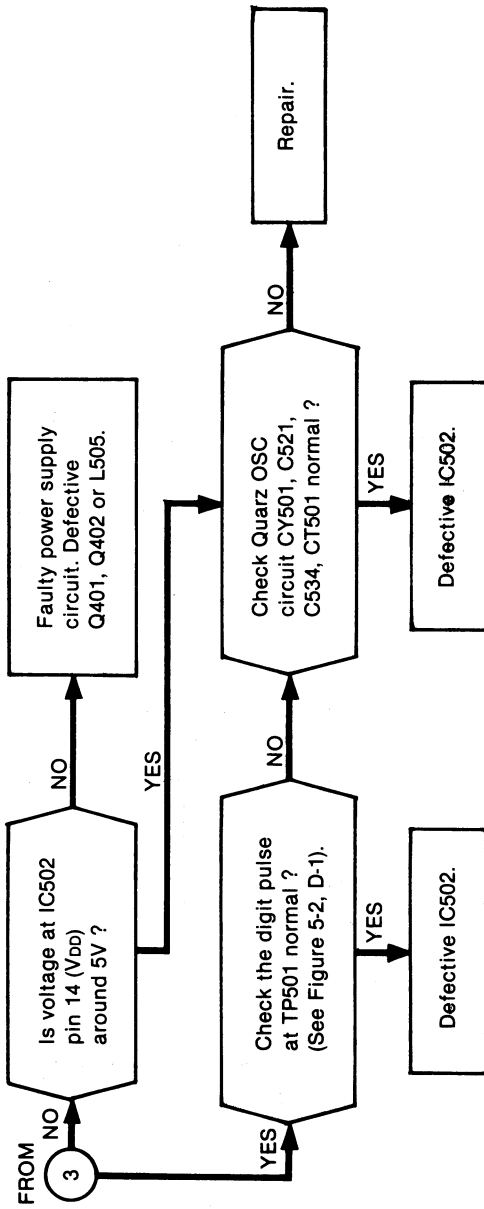
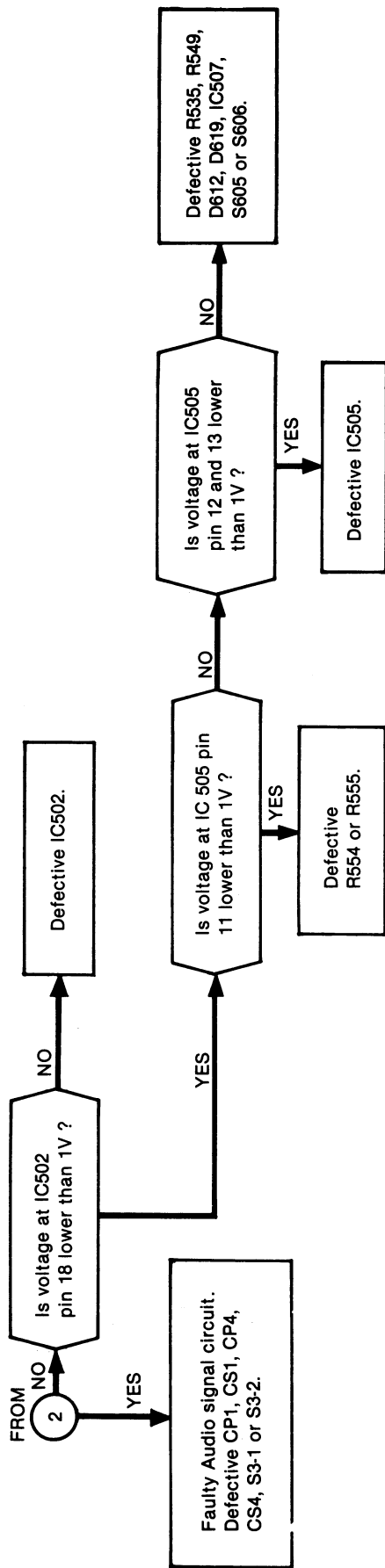

C. NO AM RADIO (GOOD FM RADIO)

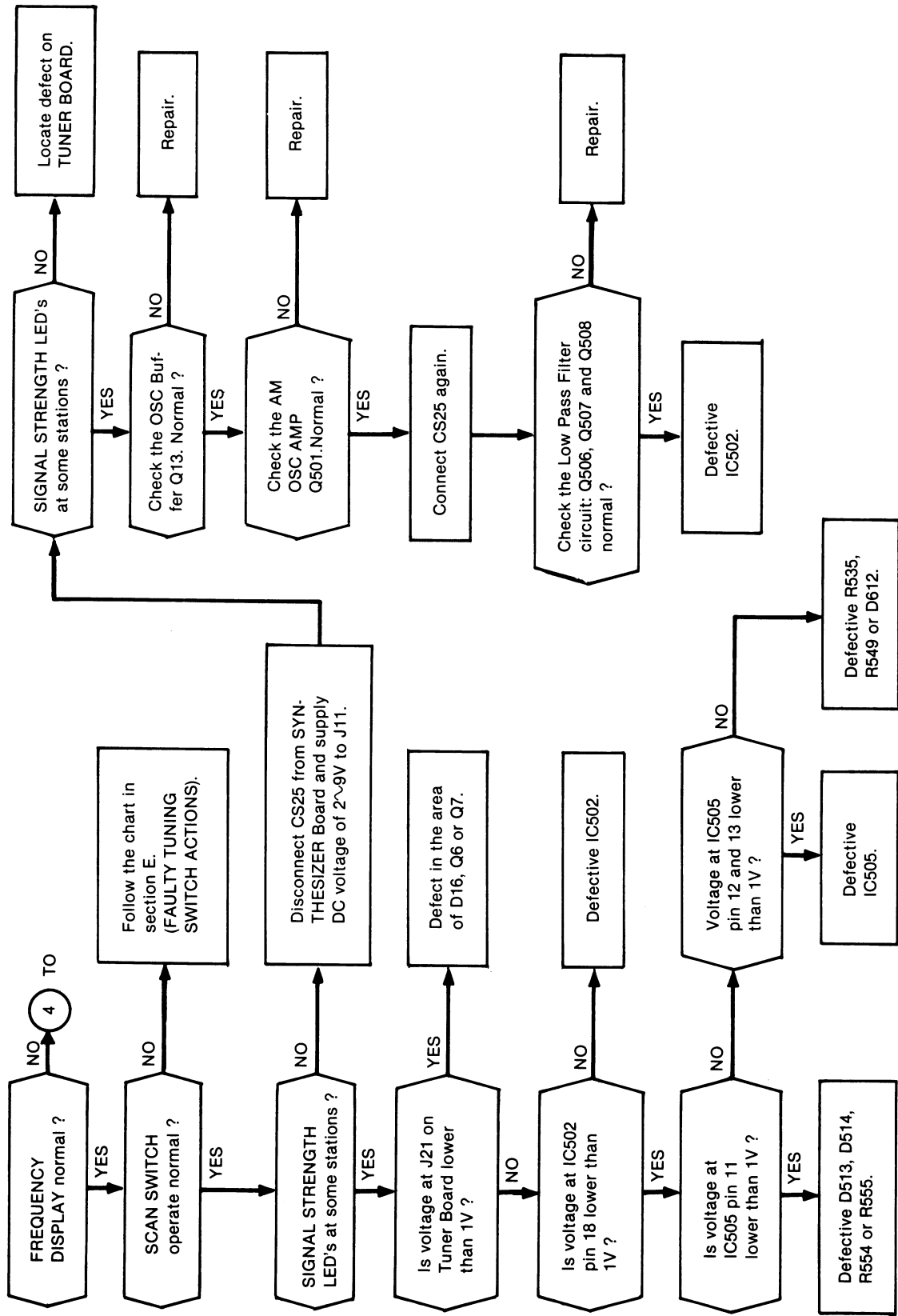

C. NO AM RADIO (Continued)
(GOOD FM RADIO)

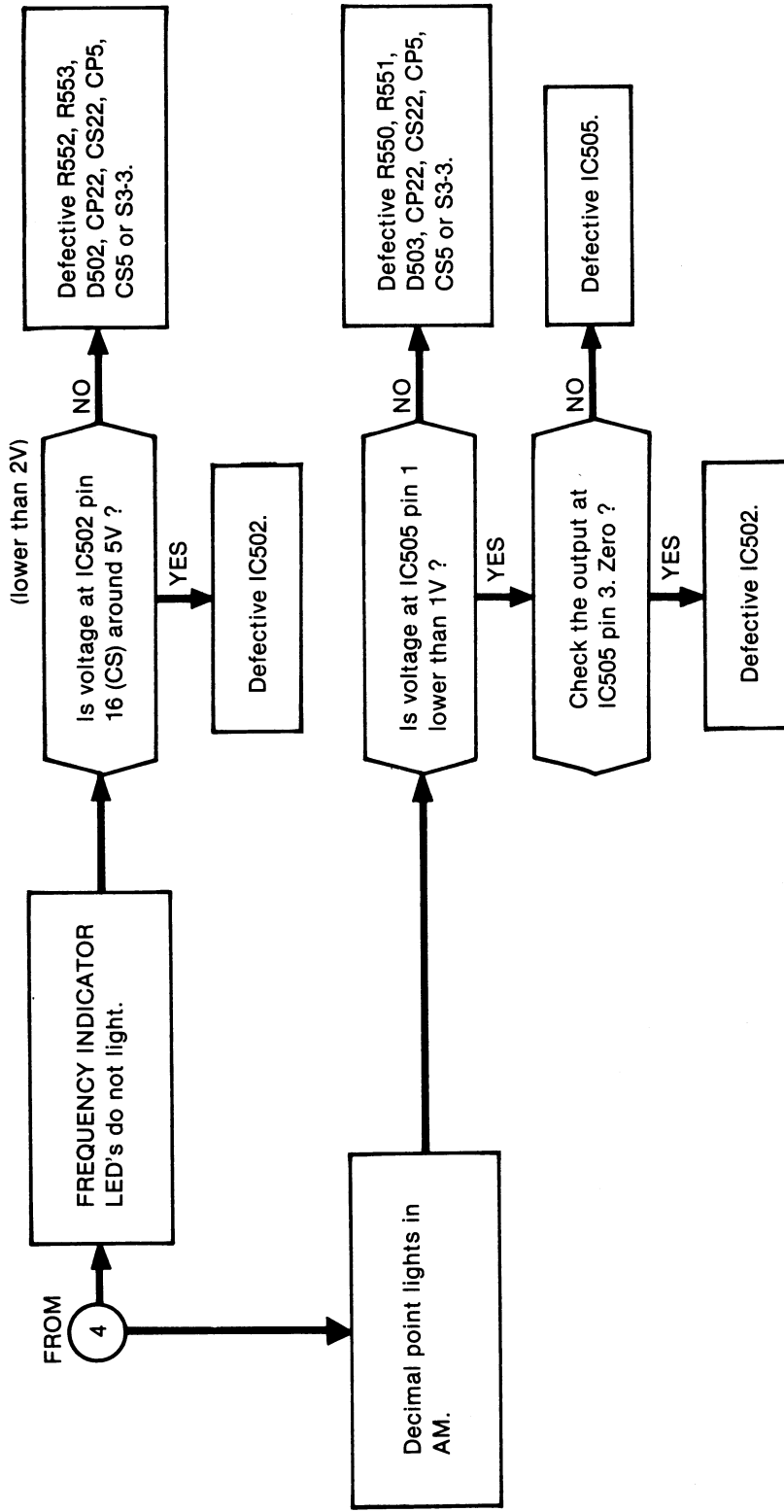

D. NO FM RADIO
(GOOD AM RADIO)

[CHECK ON FM FUNCTION, NOT FM MPX.]
[OFF the FM MUTE SWITCH.]

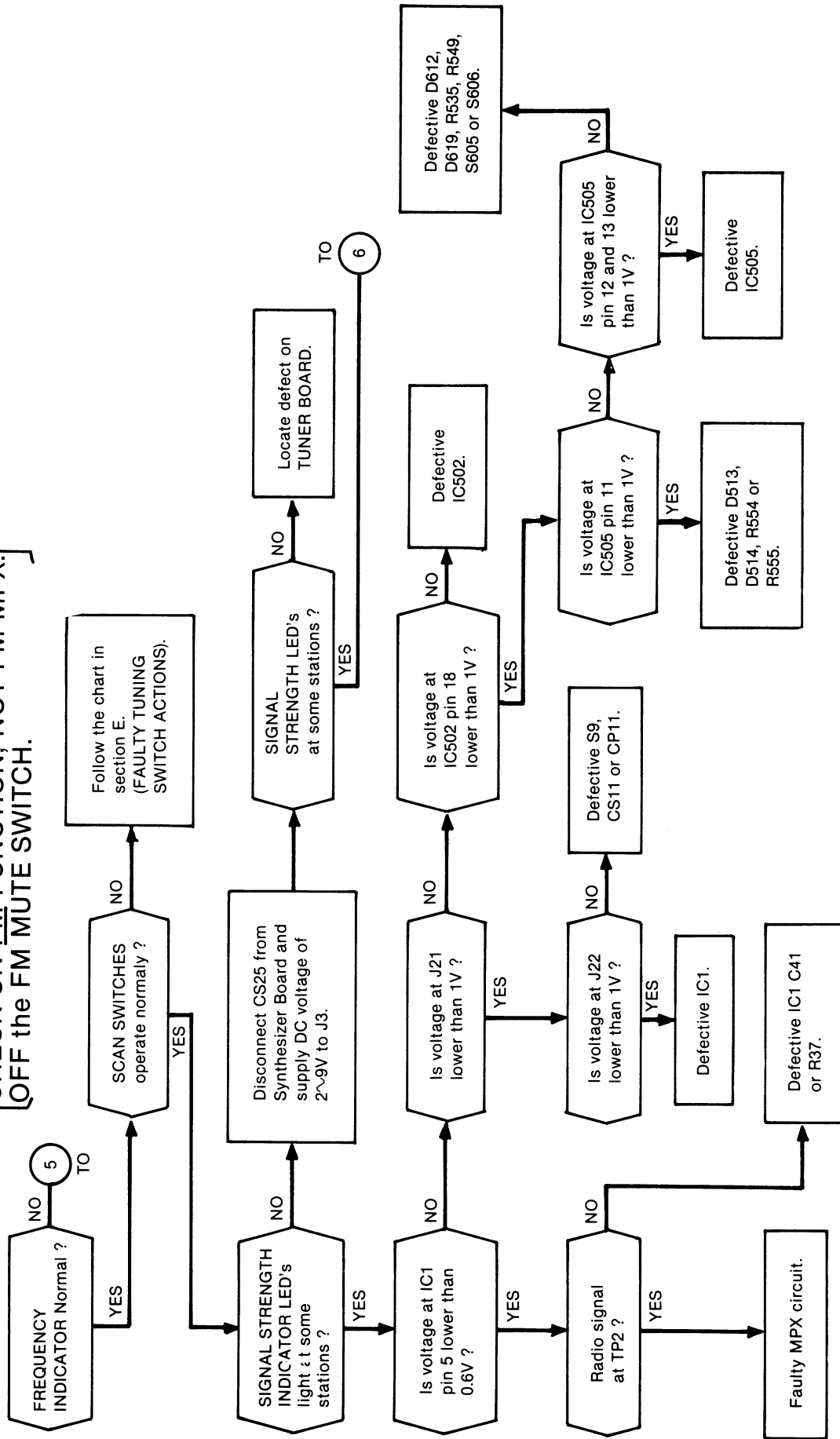

D. NO FM RADIO (Continued)

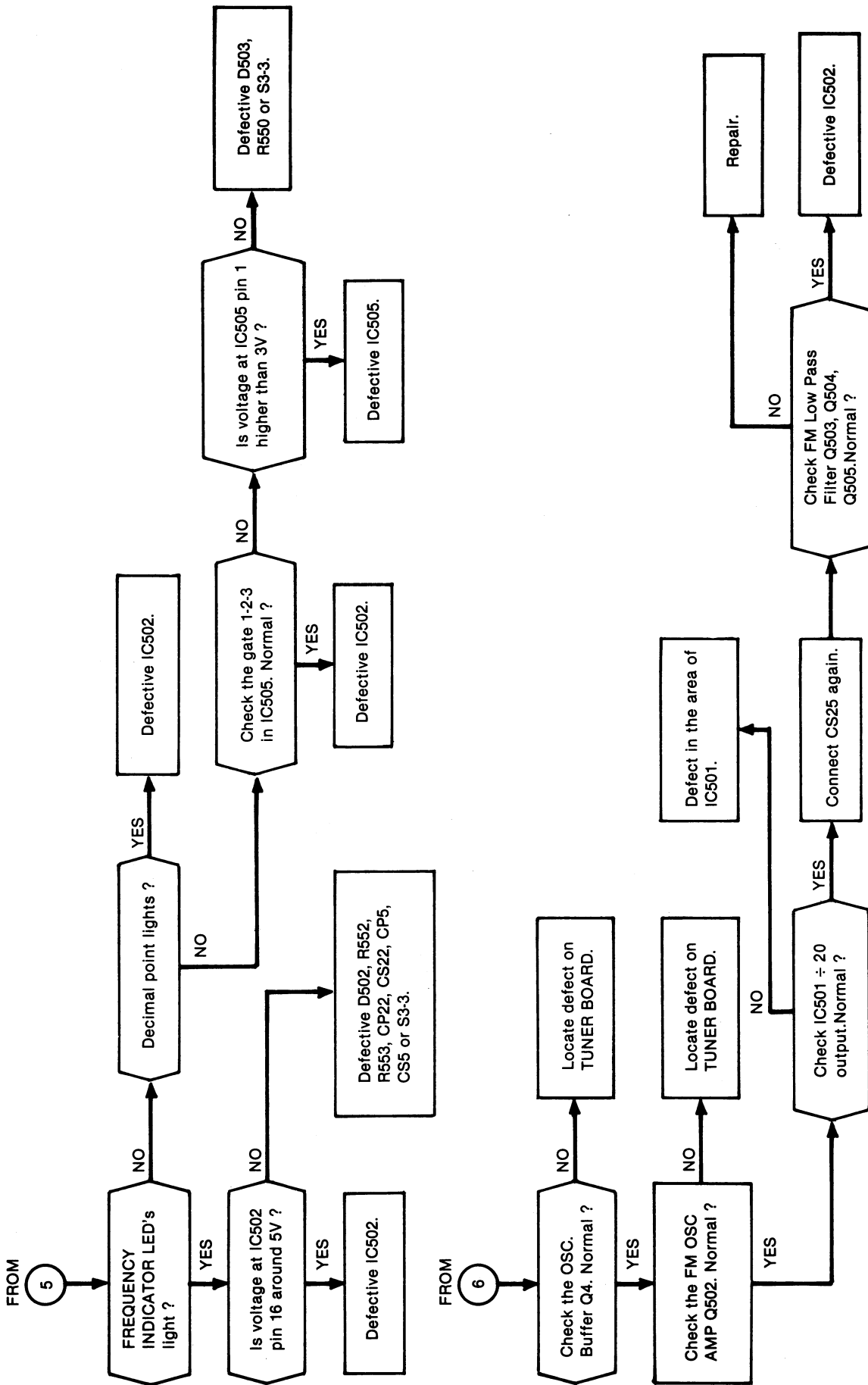

E. FAULTY TUNING SWITCH ACTIONS

E-1

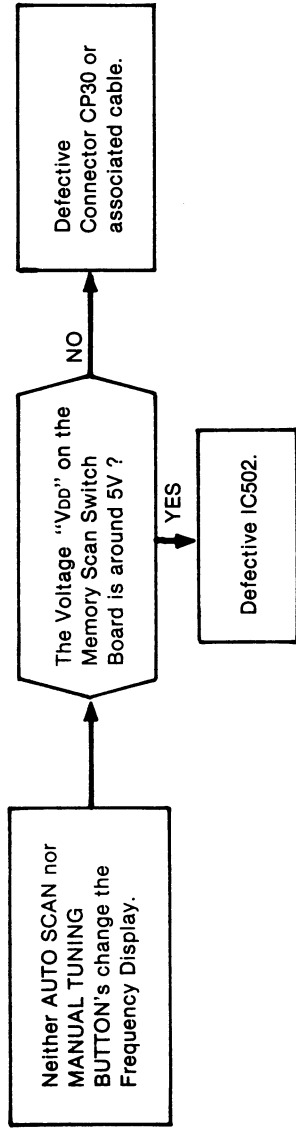

E-2

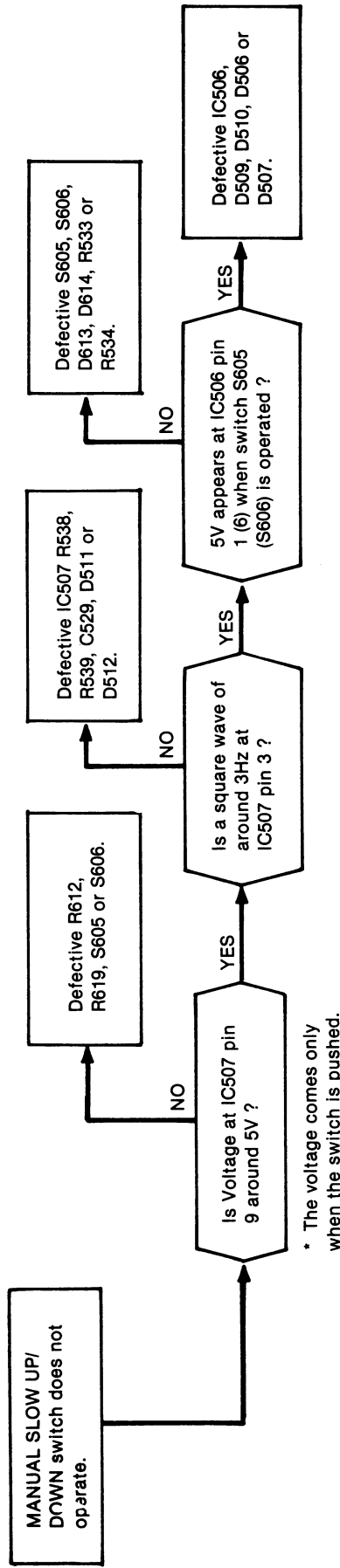

E-3

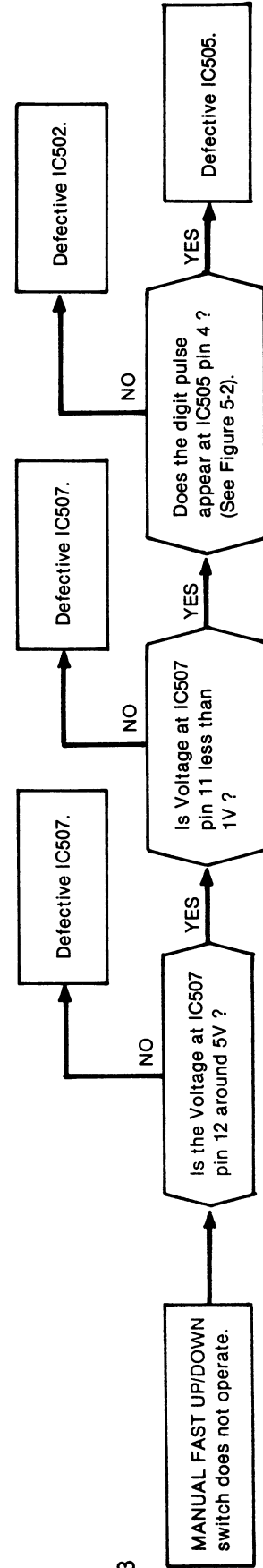

E. FAULTY TUNING SWITCH ACTIONS (Continued)

E-4

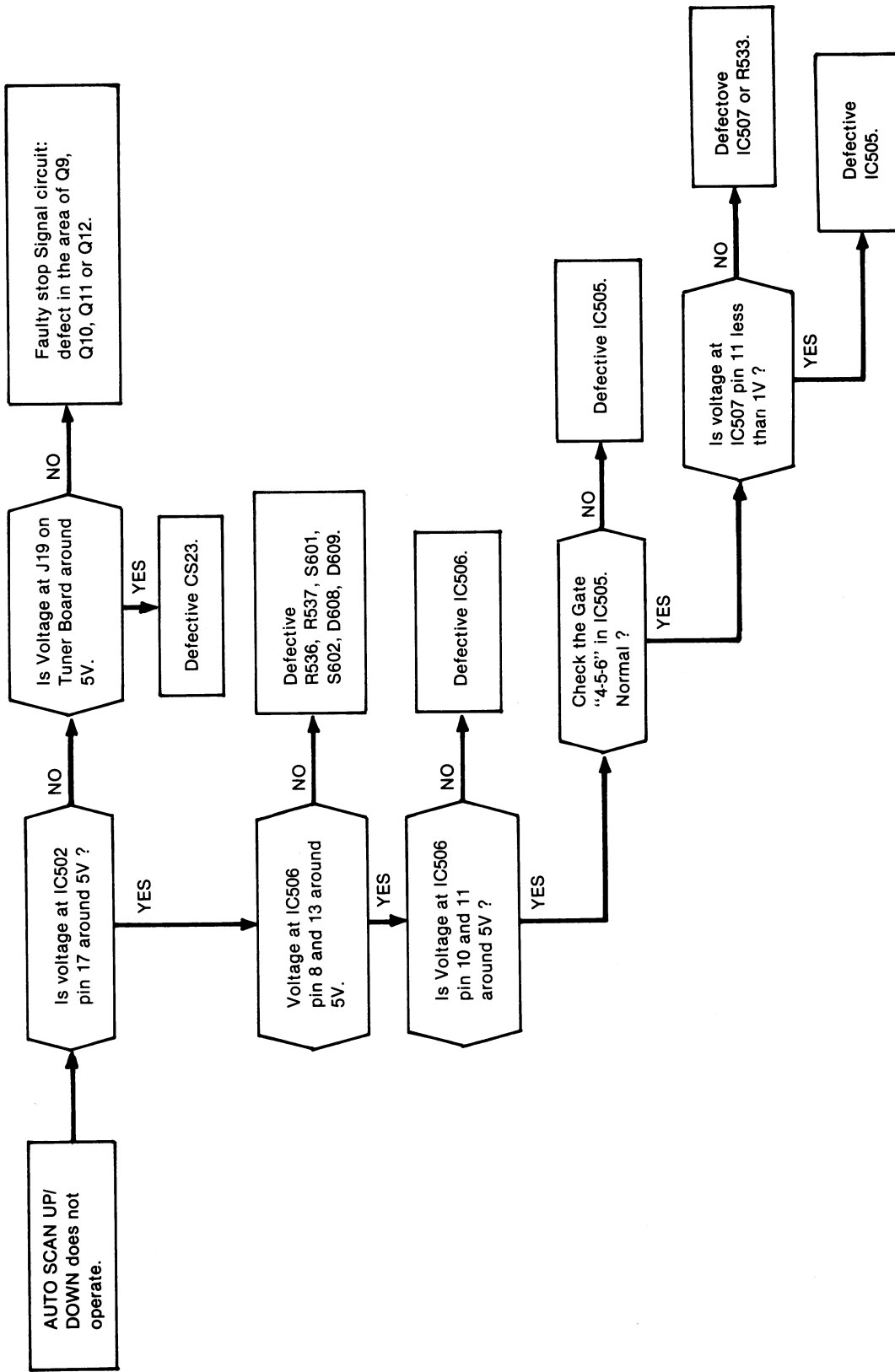

**F. FAULTY AUTO SCANNING
(DO NOT STOP AT ANY STATION)**

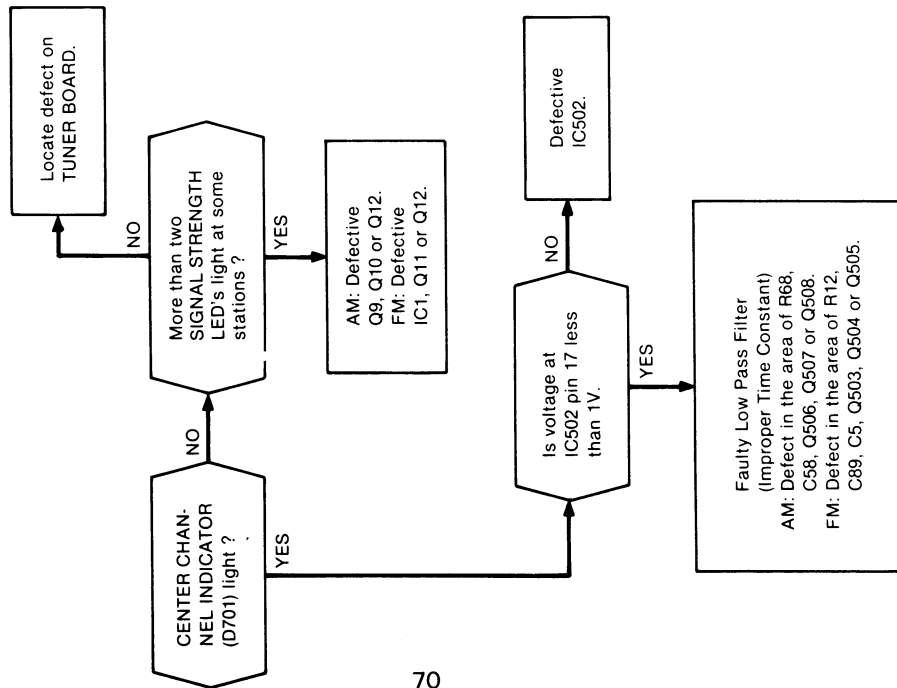

**G. FAULTY FREQUENCY DISPLAY
(OTHERWISE PROPER RADIO OPERATION)**

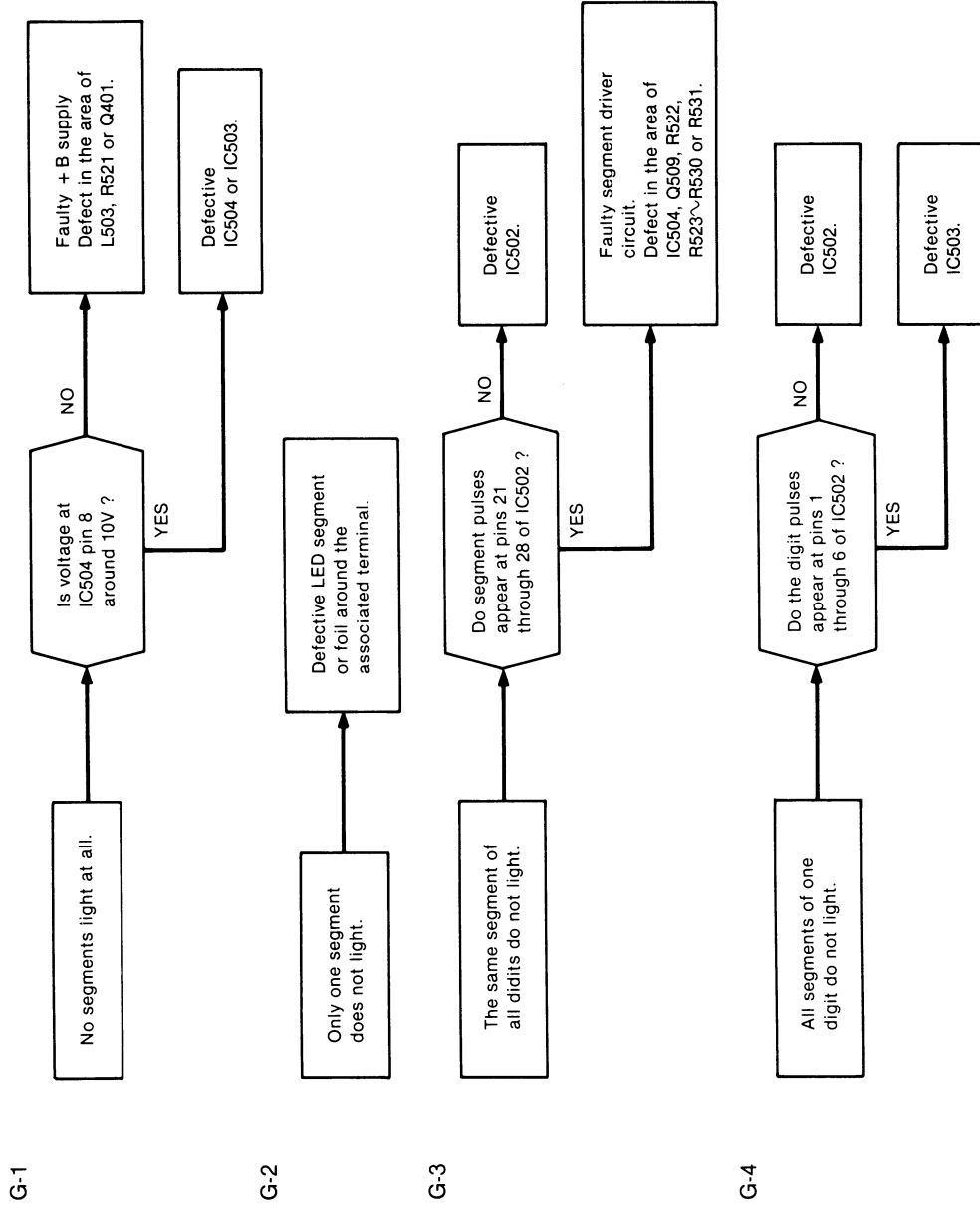

H. FAULTY MEMORY PRESET

H-1

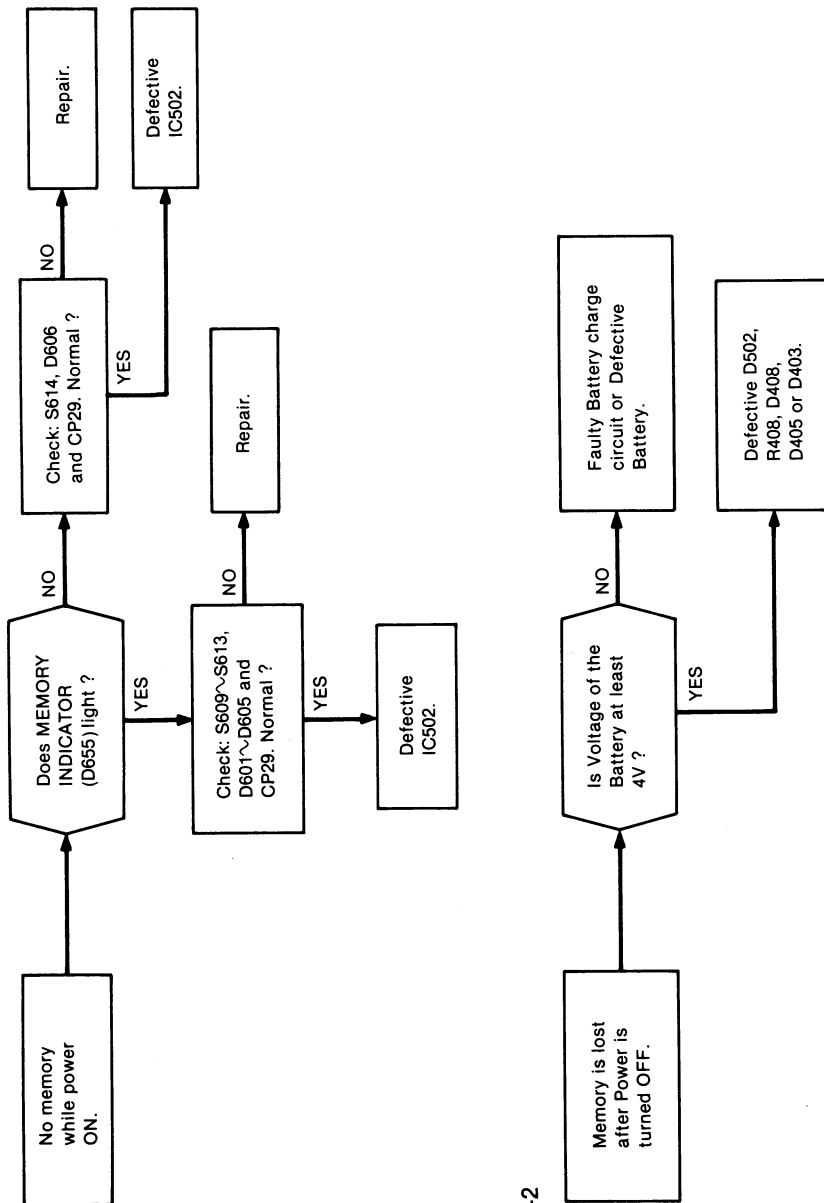

H-2

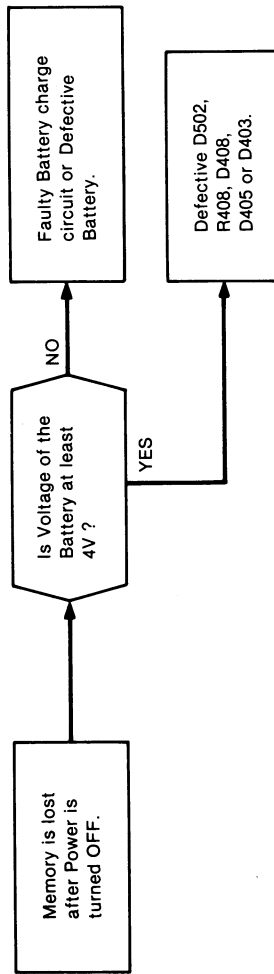

* Disconnect the power cord.

I. NOISE IN AUTO OR MANUAL FAST SCANNING MODE (GOOD FM MUTE)

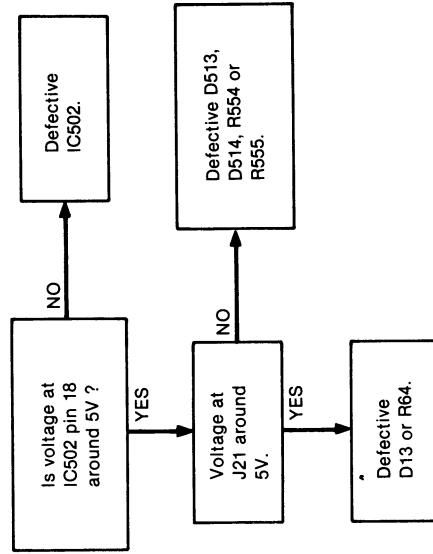

NATIONAL
Sears
TRAINING