



JCX 2600K



SANYO HIGH-FIDELITY STEREO RECEIVER

OPERATING INSTRUCTIONS

LIMITED WARRANTY TO ORIGINAL PURCHASER

RECEIVERS

This Sanyo Product is warranted against manufacturing defects in materials and workmanship for the period specified:

PARTS	LABOR
2 YEARS	2 YEARS

Sanyo will repair or replace (at our option) at no charge, any part(s) found to be defective during the warranty period.

This warranty period starts on the date of purchase by the original consumer.

The warranty repairs must be performed at a Sanyo Authorized Service Station. A list of the Sanyo Authorized Service Centers can be obtained from the dealer, or from

Sanyo Electric, Inc.
1200 W. Artesia Blvd., P.O. Box 5177, Compton, CA 90220
(213) 537 - 5830

OBLIGATION OF THE ORIGINAL OWNER

1. The dealer's original dated bill of sale must be retained as a proof of purchase and must be presented to the Sanyo Authorized Service Station.
2. Transportation to and from the service center is the responsibility of the customer.

EXCLUSIONS OF THE WARRANTY

The warranty does not cover accident, misuse, fire, flood and other Acts of God, incorrect line voltage, damage caused by improper installation, labor cost of removing or reinstalling of the product for repairs, improper or unauthorized repair, cartridge and stylus, antenna, broken or marred cabinet, when applicable; 50/60 cycle/60/50 cycles conversions, missing or altered serial numbers and customer adjustments that are not covered in the instruction book. This warranty is valid only on products purchased and used in the United States of America.

EFFECTIVE JULY 4, 1975

MARCH 1976

ATTENTION

For your protection in the event of theft or loss of this product, please fill in the information requested below:

Model No. _____ Serial No. _____
(Located on back or bottom side of unit)

Date of Purchase _____ Purchased Price _____

Where Purchase _____

WARNING: TO PREVENT FIRE OR SHOCK HAZARD, DO NOT EXPOSE THIS APPLIANCE TO RAIN OR MOISTURE.

DESCRIPTION

The SANYO JCX 2600K High-fidelity Stereo Receiver is especially designed for musical entertainment with ease of operation and trouble-free performance. For full enjoyment

and the versatility of this receiver, read the following operating instructions to familiarize yourself with it.

CONNECTIONS

Speaker Connections (Fig. 1)

The receiver provides terminals for two separate speaker systems. The two speaker systems arrangement enables you to select whatever speaker systems are needed for proper reproduction or to enjoy reproduction in the other room. The speaker terminals will accept speakers of 4 to 16 ohms impedance. If you intend to play the two speaker systems A and B simultaneously, 8 to 16 ohms impedance speakers should be employed. The speaker lead wires should be connected to the speaker terminals with the proper polarity. The red terminals are (+) positive and black terminals are (-) negative.

NOTE: Under wrong polarity connection, proper stereo reproduction can not be obtained.

When using at maximum continuous power with 4 ohms speaker per channel or two 8 ohms speakers in parallel per channel, the thermal fuses in the power transformers may be blown to protect the receiver from damage.

The speaker lead wires should be placed as far away as possible from the external ferrite bar antenna to avoid noisy AM reception.

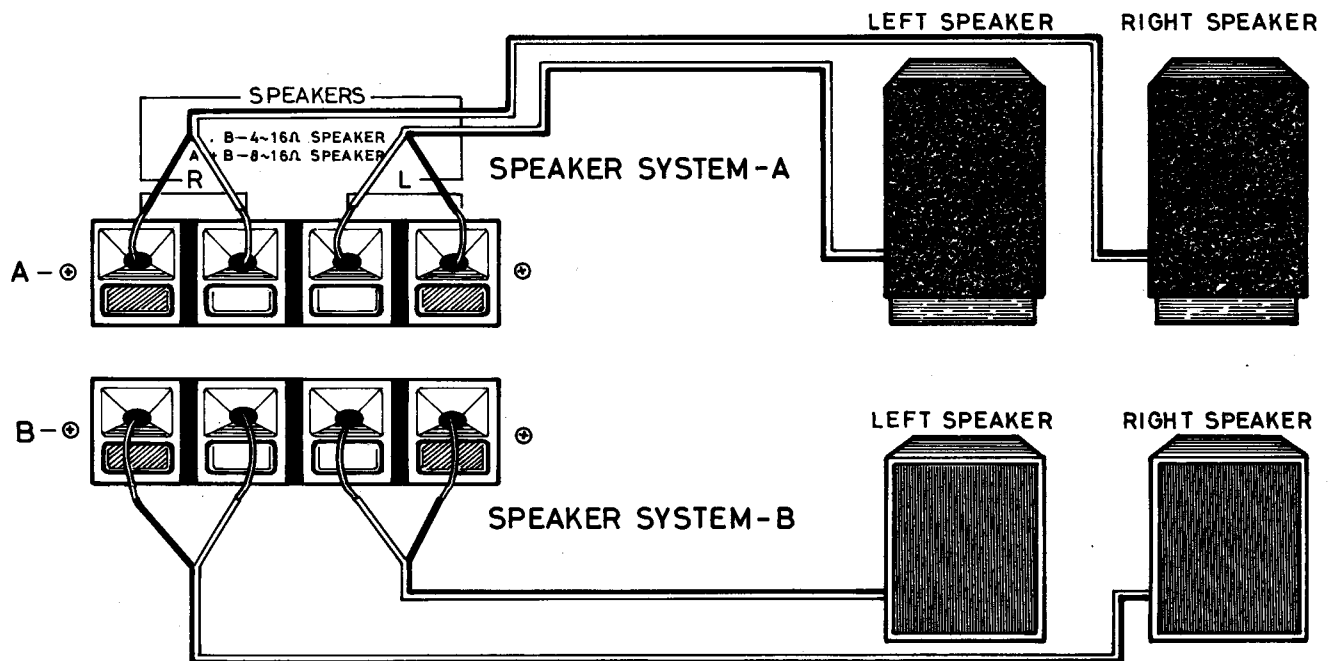
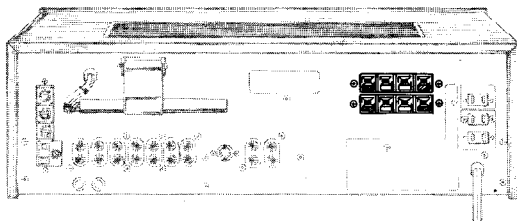

Fig. 1

1. Strip off the insulation of speaker lead wire about 1/2" from the end of it (Fig. 2).
2. Twist the strands for easy connection.
3. While pushing back the button of terminal, insert the strand into the jaw and then release the button.

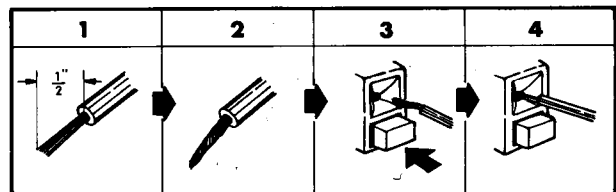

Fig. 2

Antennas (Fig. 3)

To obtain satisfactory radio reception of broadcasts, suitable indoor or outdoor antenna connections may be required. The outdoor antenna location is one of the most important factors,

because broadcasts conditions may vary from place to place. Also be careful that the place selected will have no interference or noise problems.

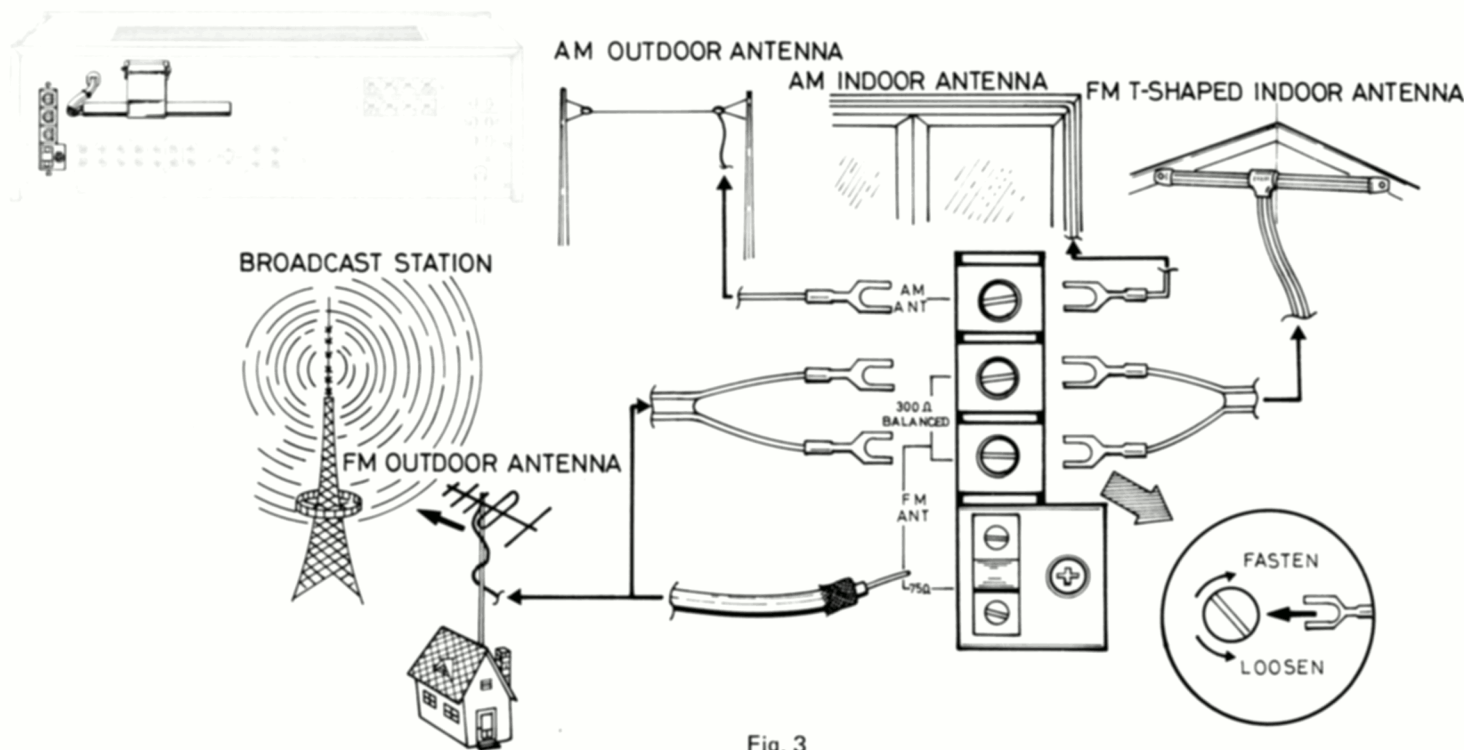

Fig. 3

AM Antenna

In your local area, with the ferrite bar antenna is satisfactory to receive local broadcasts. Move it as shown in Fig. 4. If the reception with external ferrite bar antenna is unsatisfactory, the indoor or outdoor external antenna installation will be necessary. Connect insulated, flexible, single-conductor wire (which may be obtained from an electrical parts dealer) to AM ANT. terminal and run it in a straight line along a non-metallic wall or under a rug for an indoor installation. If further improved reception is required, outdoor antenna should be employed. Consult your dealer.

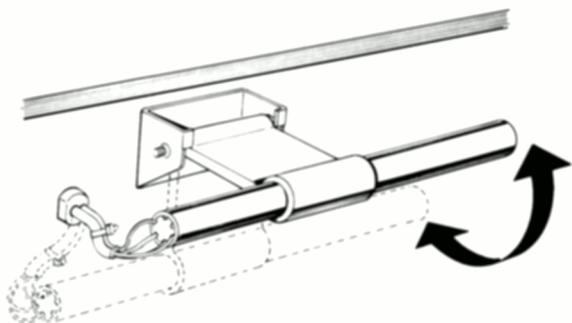

Fig. 4

FM Antenna

In your local area, with the supplied T-shaped indoor antenna is satisfactory to receive local broadcasts. Reception in a fringe

area or in a steel frame building will require an outdoor antenna, especially for effective, noise-free FM-stereo reception.

Near by a busy thoroughfare, industrial area, automotive ignition system or electrical machinery interference noise can possibly enter through the antenna cable. To avoid these interferences, coaxial cable should be used instead of 300-ohm twin lead (Fig. 5). It may be obtained from a electrical parts dealer and it should be connected to the 75-ohm terminals of FM ANT. The antenna cable should be as short as possible for noise-free reception.

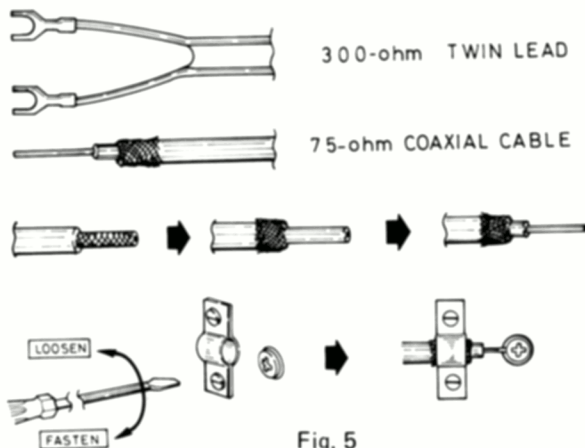

Fig. 5

Jacks (Fig. 6)

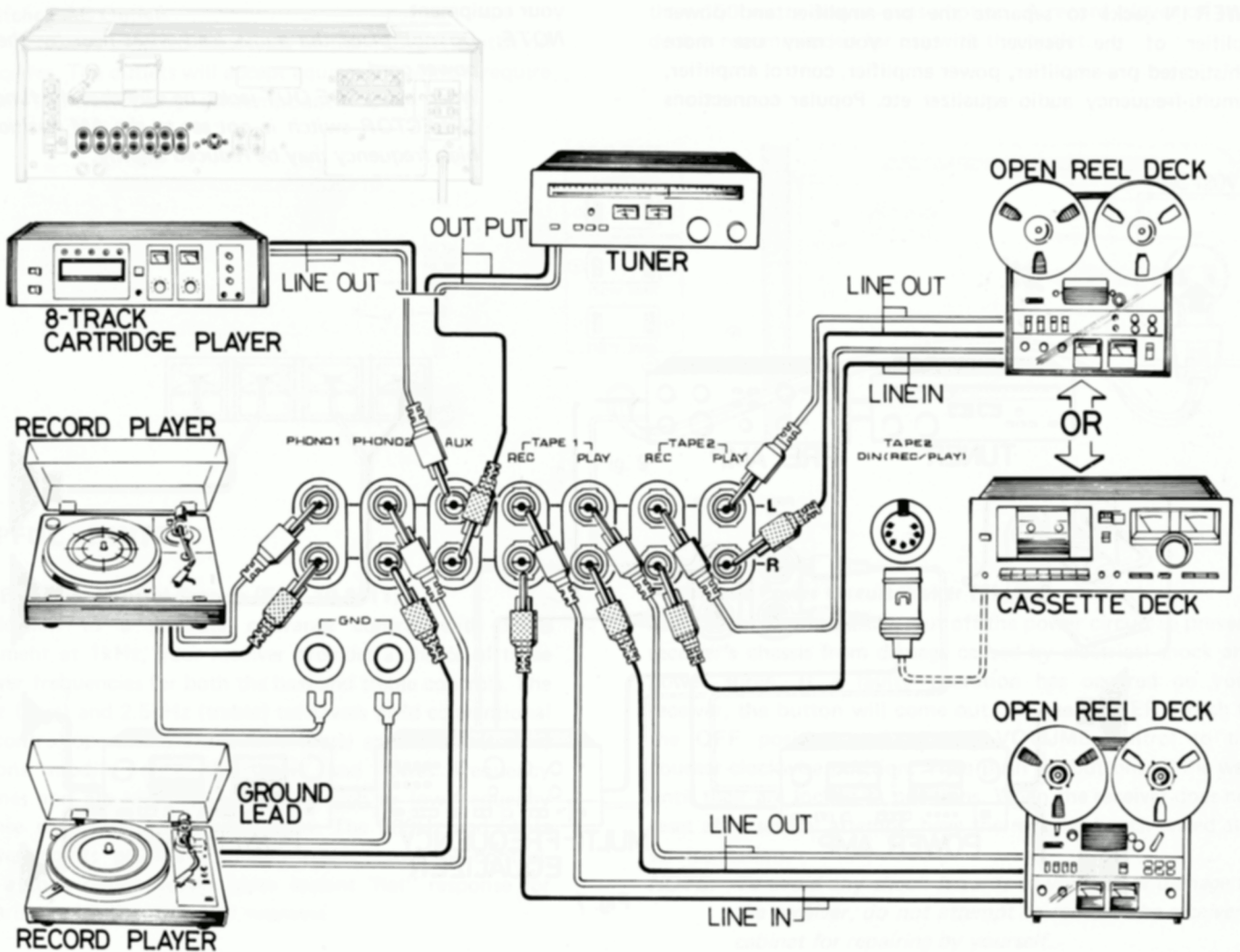

Fig. 6

PHONO 1 & PHONO 2

The two pairs of PHONO jacks enable the use of two stereo record players using magnetic cartridges. Your first record player should be connected to PHONO 1 and second one to PHONO 2 jacks. If the record player has a ground lead with spade or hook lug, connect its free end to the GND terminal. This may be effective for hum-free record playback.

NOTE: The Moving Magnet (MM) and Induced Magnet (IM) type cartridges should be employed. Other type cartridges such as Moving Coil (MC) type are not recommended.

AUX

These jacks are provided for furthering the versatility of the receiver with auxiliary sources, such as an 8-track cartridge player, TV sound tuner or other music source.

TAPE 1, TAPE 2 & TAPE 2 (DIN REC/PLAY)

These TAPE jacks will permit you to connect two tape decks at the same time, one to the TAPE 1 jacks and another to either TAPE 2 or TAPE 2 (DIN) jacks. A tape deck which provides DIN jack may be connected to TAPE 2 (DIN REC/PLAY) jack. When one tape deck has been connected to TAPE 2 (DIN) jack, another have to be connected to TAPE 1 jacks, if desired. These jacks permits you to record from one program source to another. Also two tape decks respectively can record simultaneously and duplicate from one tape deck to another through the receiver. Connect REC jacks of the receiver to LINE IN jacks of the tape deck for recording and connect PLAY jacks of the receiver to LINE OUT jacks of the tape deck for playback through the receiver. If your tape deck provides the DIN (REC/PLAY) jack, connect the TAPE 2 (DIN REC/PLAY) jack of receiver to the DIN (REC/PLAY) jack of your tape deck for recording and playback through your receiver.

NOTE: Proper stereo operation is not obtained if the connections are wrong.

PRE OUT & POWER IN (Fig. 7)

These jacks provide furthering the ability of receiver. Remove the two jumper plugs conjunctive between the PRE OUT and POWER IN jacks to separate the pre-amplifier and power amplifier of the receiver in turn you may use more sophisticated pre-amplifier, power amplifier, control amplifier, or multi-frequency audio equalizer etc. Popular connections

are shown in Fig. 7 and further more detailed connections should be followed with the instruction manual provided with your equipment.

NOTE: Do not place the audio lead wires near by the AC power cord.

When using PRE OUT jacks, be sure that the function SELECTOR switch is not set to the AM position or high frequency may be reduced slightly.

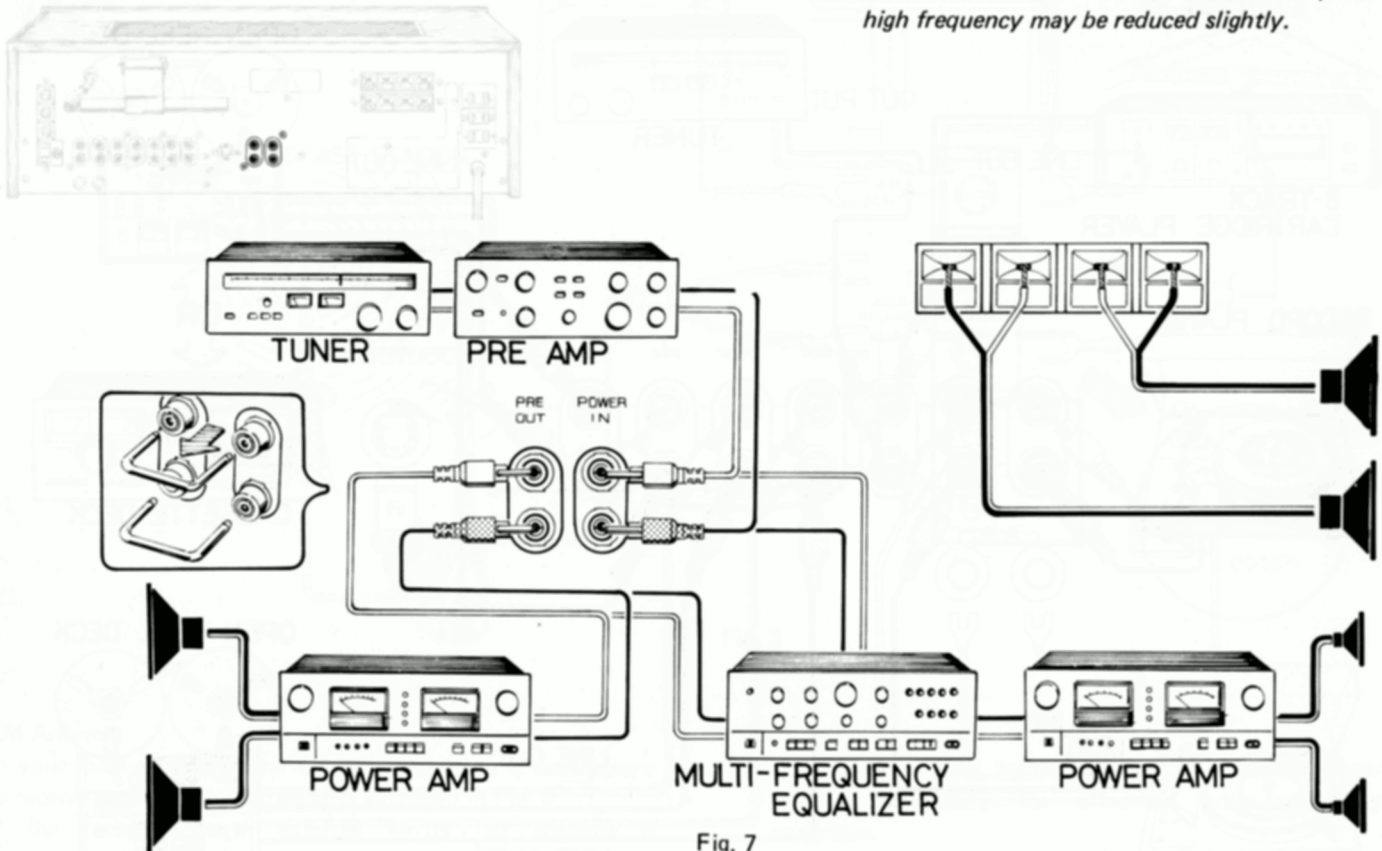

Fig. 7

PHONES (Fig. 8)

Provided for private listening with an optional stereo headphone (low impedance). The headphone jack will accept 1/4" plug. For headphone listening, the speaker switches A and B should be set to the OFF position if disconnection of the external speaker systems is so desired. Before plugging in the headphone, the volume control should be set in the maximum counter-clockwise position to avoid damage to your ears and headphone. Then increase the listening sound level slowly with volume control set to your preference.

MICROPHONE (Fig. 8)

Provided for use the receiver as a public address system with an optional microphone (low impedance). The jack will accept 1/4" plug. Plug the microphone into the MIC jack. Before plugging in the microphone, set the VOLUME control to the maximum counter-clockwise position.

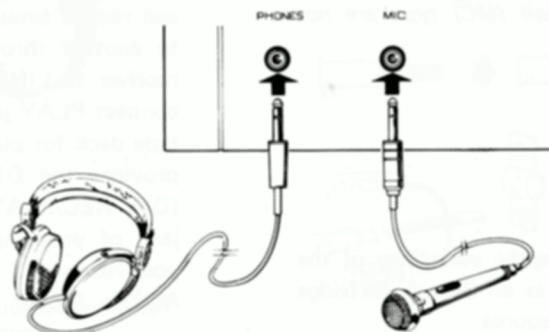

Fig. 8

Power (Fig. 9)

AC Power Cord

Plug the attached power cord to the AC 120V 60Hz outlet.

Unswitched AC Outlets

Power is always supplied regardless of the POWER switch on the receiver. The outlets will accept equipments which require less than 150 watts power consumption.

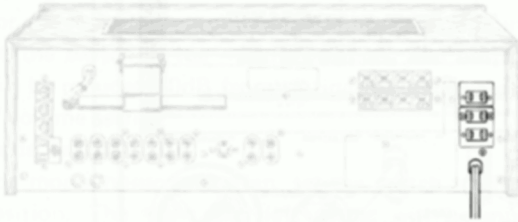

Switched AC Outlet

Power is turned on or off by the POWER switch on the receiver. The outlet will accept equipment which requires less than 150 watts power consumption. A record player or tape deck is recommended for use with this outlet.

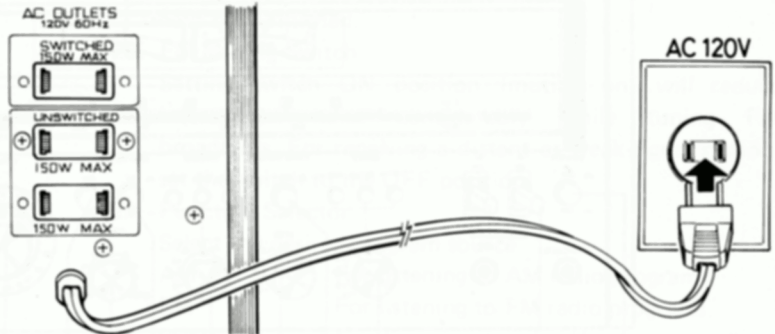

Fig. 9

HELPFUL HINTS

Tone Equalizer Control System (Figs. 10 & 11)

In addition to a separate midrange control with ± 5 dB adjustment at 1kHz, your receiver provides a choice of three turnover frequencies for both the bass and treble controls. The 400Hz (bass) and 2.5kHz (treble) turnovers yield conventional tone control operation. The 100Hz (bass) and 10kHz (treble) positions modify only the upper and lower frequency extremes and are ideal for correcting high or low frequency response rolloff in a speaker system. The 200Hz and 5kHz turnover points provide an intermediate range of control, while a tone defeat switch gives instant 'flat' response for comparison with the corrected response.

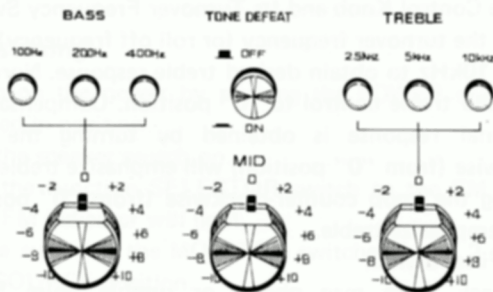

Fig. 10

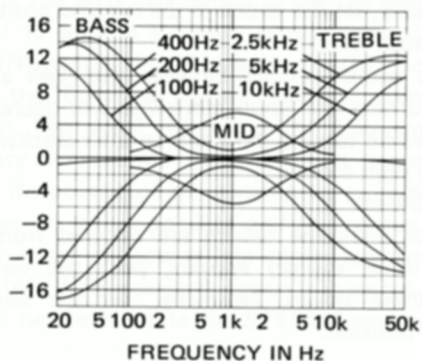

Fig. 11

Automatic Power Circuit Braker (Fig. 12)

This braker automatically shut off the power circuit to prevent receiver's chassis from damage caused by electrical shock and power surge. If a faulty operation has occurred on your receiver, the button will come out. Set the POWER switch to the OFF position and set the VOLUME control to the counter-clockwise position. Then push the buttons all the way until their are locked in positions. When the receiver does not reset after several attemps, have the receiver bench tested at a service station.

NOTE: To avoid any shock hazards to yourself or damage to the receiver, do not attempt to remove the receiver's cabinet for repairing by yourself.

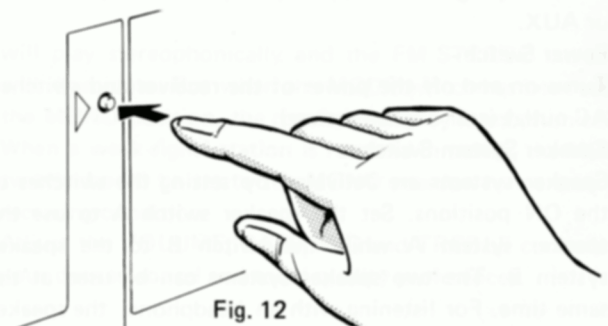

Fig. 12

Protection Circuit

When the power is on, the sounds will not appear for several seconds. This is simply due to the protection circuit which protects speakers from possible damage caused by electric shock, etc. Furthermore, when the receiver is being operated in a extreme hot or ill-ventilated area, the sound will also disappear automatically by means of this amplifier protection circuit. So be sure that the receiver is always placed in cool and well-ventilated area. The sound will come on again soon after the receiver becomes cool. But if the receiver still remains inoperative, consult your local SANYO Service Station.

CONTROLS AND THEIR FUNCTIONS (Fig. 13)

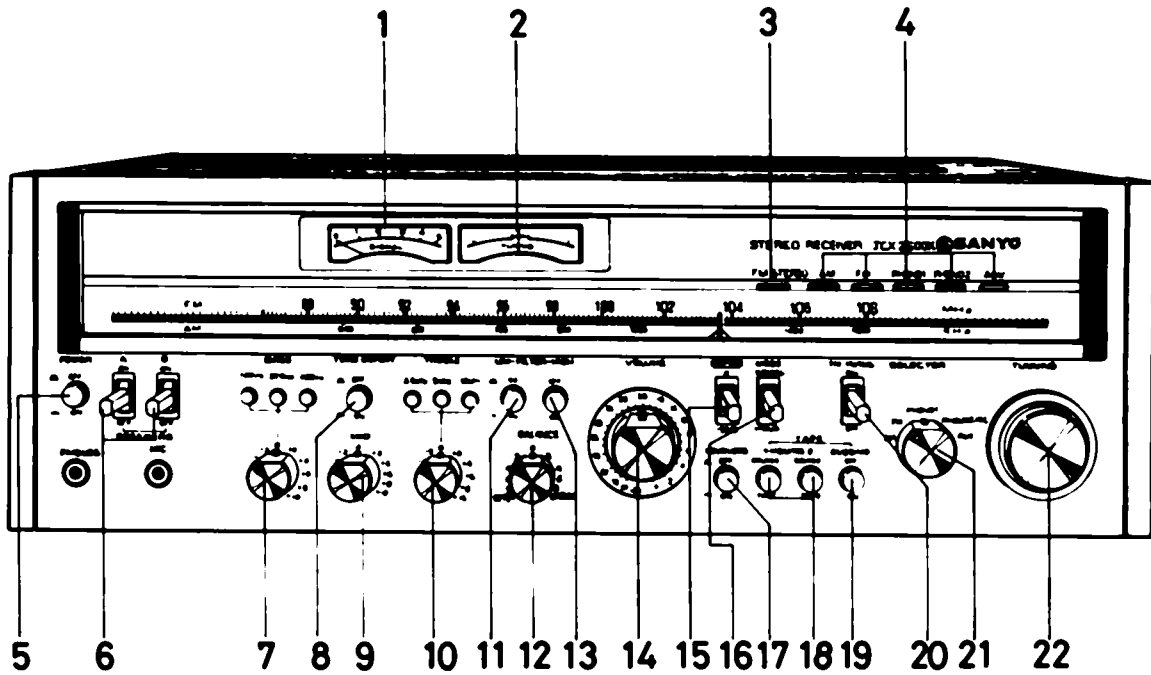

Fig. 13

1. AM-FM Signal Meter

Indicates receiving strength condition of AM and FM broadcasts.

2. FM Tuning Meter

Indicates FM accuracy tuning condition only. Tune in a FM station by centering pointer within the center segment of the meter.

3. FM Stereo Indicator

Indicates that the FM stereo broadcast is being received.

4. Function Indicators

Indicates program source, AM, FM, PHONO 1, PHONO 2 or AUX.

5. Power Switch

Turns on and off the power of the receiver and switched AC outlet (rear of the receiver).

6. Speaker System Switches

Speaker systems are activated by setting the switches to the ON positions. Set the speaker switch A to use the speaker system A while the switch B to the speaker system B. The two speaker systems can be used at the same time. For listening with an headphone, the speaker switches should be set to the OFF positions.

7. Bass Control Knob and Its Turnover Frequency Switches

Select the turnover frequency (or roll off frequency) 100, 200 or 400Hz to obtain desired bass response. Normally, keep the bass control to "0" position. Compensation of tonal response is obtained by turning the knob clockwise (from "0" position) for emphasized bass, while turning the knob counter-clockwise (from "0" position) will demphasize the bass response of your sound system.

8. Tone Defeat Switch

Natural sound (non-adjusted tone frequency response) is

obtained by simply pushing the switch to its locked in position.

9. Mid Range Control Knob

Normally, keep the mid control to "0" position. Compensation of tonal response is obtained by turning the knob clockwise (from "0" position) will emphasize mid range frequency while turning the knob counter-clockwise (from "0" position) will demphasize mid range frequency.

10. Treble Control Knob and Its Turnover Frequency Switches

Select the turnover frequency (or roll off frequency) 2.5k, 5k or 10kHz to obtain desired treble response. Normally, keep the treble control to "0" position. Compensation of tonal response is obtained by turning the knob clockwise (from "0" position) will emphasize treble while turning the knob counter-clockwise (from "0" position) will demphasize treble.

11. Low Filter Switch

Feedback from mag phono or rumble noise (which occurred from worn record, motor of the record player or other source) appears, push the switch to attenuate this noise. Normally, set the switch in the released position.

12. Balance Control Knob

Adjusts the sound balance between the right and left speakers. Turning the knob clockwise will decrease the left sound while turning the knob counter-clockwise will decrease the right sound.

13. High Filter Switch

If scratch or hiss-noise (which are occurred from worn record or other source) appears, push the switch to attenuate these noises. Normally, set the switch in the released position.

14. Volume Control Knob

The output sound level is indicated with "dB". Adjust the right and left output sound levels. Turning the knob clockwise will increase the output level while counter-clockwise will decrease output level. Before operating the function SELECTOR or turning on the power, the volume control should be set in the maximum counter-clockwise position to avoid damage.

15. Muting Switch

For reducing the output sound temporarily and instantly, set the switch to the -20dB position. The output sound will be reduced 20dB from setting volume level regardless of volume setting.

16. Mode Switch

For monophonic operation, set the switch to the MONO position. The right and left sound will be mixed and reproduced from both speakers. For stereophonic operation, set the switch to the STEREO position. The right and left sound source will be separately reproduced from right and left speakers.

17. Loudness Control Switch

LOUDNESS control compensates the loss of high and low frequencies when listening at low volume levels. When switched on, it will emphasize lower and higher frequencies.

18. Monitor Switches

For tape deck playback, set the switch to the TAPE position. The MONITOR switch has priority than the

function SELECTOR. When the tape deck is connected to TAPE 1 jacks use the MONITOR-1 switch while TAPE 2 jacks to the MONITOR-2 switch.

19. Dubbing Switch

For duplicating, push the switch to the ON position. When two tape deck have been connected, dubbing from TAPE 1 deck to TAPE 2 and vice versa are possible. The switch should be set to the OFF position after dubbing has been finished.

20. FM Muting Switch

Setting switch ON position (muting on) will reduce interstation noise considerably while tuning FM broadcasts. For receiving a distant or weak-signal station, set the switch to the OFF position.

21. Function Selector

Select the desired program source

AM For listening to AM radio programs.

FM For listening to FM radio programs.

PHONO 1 For listening to your first record player connected to PHONO 1 jacks.

PHONO 2/MIC For listening to your second record player connected to PHONO 2 jacks or for using the microphone.

AUX For listening to your equipment utilizing AUX jacks.

22. Tuning Control Knob

Turn the knob for tuning in any AM or FM broadcast stations.

OPERATIONS

FM Listening

1. Turn on the power by pushing the POWER switch to its locked-in position.
2. Set the speaker switch on.
3. Set the function SELECTOR switch to the FM position. The FM indicator will light.
4. Make sure that the MONITOR switches 1 and 2 are set to the SOURCE position.
5. Set the MODE switch to MONO or STEREO position as desired.
6. Set the FM MUTING switch to the ON position, but if you intend to tune in a distant station (weak-signal), the FM MUTING switch should be set to the OFF position.
7. Turn the TUNING control knob to tune in a desired station. The signal meter and FM tuning meter helps you for easy and accurate tuning. The best reception is obtained when the pointer of the signal meter deflects to the highest number as far as possible and the pointer of the tuning center meter deflects within center segment of the meter (Fig. 14). If the received station is in stereo and the MODE switch has been set to the STEREO position, the receiver

will play stereophonically and the FM STEREO indicator will illuminate. But when the MODE switch has been set to the MONO position, the receiver will play monophonically. When a weak-signal station is received in stereo, the MODE switch should be set to the MONO position to increase the receiving condition.

8. Adjust the VOLUME, BASS, MID and TREBLE controls to your desired sound and tonal quality preferences.



Fig. 14

AM Listening

1. Turn on the power by pushing the POWER switch to its locked-in position.
2. Set the speaker switch on.
3. Set the function SELECTOR switch to the AM position. The AM indicator will light.
4. Make sure that the MONITOR switches 1 and 2 are set to the SOURCE positions.
5. Turn the TUNING control knob to tune in a desired station. The best reception is obtained when the pointer of the signal meter deflects to the highest number as far as possible.
6. Adjust the VOLUME, BASS, MID and TREBLE controls to your desired sound and tonal preferences.

NOTE: If these control knobs are set to maximum clockwise position, noise may occur. In this case, reduce the volume and tone.

Record Playback

NOTE: Be sure that the microphone is disconnected from the MIC jack when you want to play a record player connected to PHONO 2 jacks.

1. Turn on the power by pushing the POWER switch to its locked-in position.
2. Set the speaker switch on.
3. Set the function SELECTOR switch to the PHONO 1 or PHONO 2/MIC position. The PHONO 1 or PHONO 2 indicator will light.
4. Make sure that the MONITOR switches 1 and 2 are set to the SOURCE positions.
5. Set the MODE switch to the STEREO position.
6. Place a record on the record player and operate it as you would normally.
7. Adjust the VOLUME, BASS, MID and TREBLE controls to your desired sound and tonal preferences.

NOTE: The VOLUME control should be set to maximum counter-clockwise position until stylus of your record player set on the record.

Tape Deck Operations

Playback

1. If the tape deck to be played is connected to TAPE 1 jacks, set the MONITOR-1 switch to the TAPE position or if the tape deck is connected to TAPE 2, set the MONITOR-2 switch to the TAPE position. Setting of the MONITOR switch to the TAPE position will make the function SELECTOR switch inoperative.
2. Turn the tape deck to playback mode.
3. Adjust the VOLUME, BASS, MID and TREBLE controls to your desired sound and tonal preferences.

NOTE: To obtain satisfactory tone quality, do not set the function SELECTOR to the AM position.

Recording

1. Set the function SELECTOR switch to your desired source that will be recorded. For preparation of recording source, make sure that the MONITOR switches 1 and 2 are set to the SOURCE positions. The output level and tone from REC jacks or DIN jack are fixed and the VOLUME, TREBLE, MID and BASS controls will not affect the output signal.
2. Turn the tape deck to the record on mode.

NOTES: Two tape decks connected to TAPE 1 and 2 jacks can be recorded at the same time if you want.

For use with a 3-head type tape deck, the sound just recorded with 3-head tape deck is capable of being played back by setting the MONITOR switch to the TAPE position.

Duplication (Fig. 15)

This unit provides a duplication facility which can be performed both ways from tape deck 1 to tape deck 2 and vice versa.

1. Push the DUBBING switch to the ON position.
2. To duplicate from TAPE 1 to TAPE 2 (or TAPE 2 to TAPE 1), turn the tape deck 1 (or tape deck 2) to the playback mode, and the tape deck 2 (or tape deck 1) to the record mode. Then the duplication may be obtained.
3. Set the MONITOR-2 switch to the TAPE (or MONITOR-1 to the TAPE) position for monitoring.

NOTE: The DUBBING switch should be set to the OFF position when you have finished.

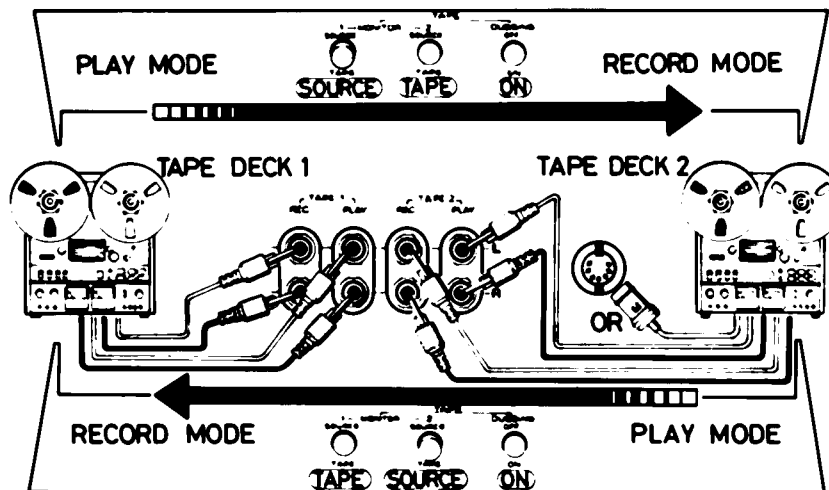

Fig. 15

Microphone Operation

1. Turn the VOLUME control to maximum counter-clockwise position.
2. Plug an optional microphone in the MIC jack. This will automatically disconnect the PHONO-2 circuit.
3. Turn on the power by pushing the POWER switch to its locked-in position.
4. Set the function SELECTOR switch to PHONO 2/MIC position.
5. Adjust the VOLUME, TREBLE, MID and BASS control knobs to your desired sound and tonal preferences.

NOTE: Do not close the microphone to the speaker and reduce the output sound as much as possible or the howling will occur.

MAINTENANCE

• Power Switch

After using the receiver, turn off the power by re-pushing the POWER switch.

• Placing the Receiver

Never place the receiver in the vicinity of extreme hot areas such as radiator or direct sunlight and also it should not be placed in a moist environment, following this advice will result in saving the receiver from damage. Placing receiver in a well ventilated area is strongly recommended.

Do not put anything on the receiver.

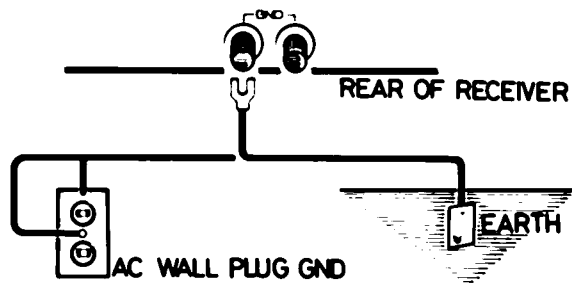

Fig. 16

Auxiliary Equipment Playback

1. Set the function SELECTOR switch to the AUX position. The AUX indicator will light.
2. Set the speaker switch on.
3. Make sure that the MONITOR switches 1 and 2 are set to the SOURCE position.
4. Operate the equipment as you would normally.
5. Adjust the VOLUME, BASS, MID and TREBLE controls to your desired sound and tonal preferences.

• Cleaning the Receiver

To keep the control panel and cabinet looking clean and beautiful, simply wipe with a soft, freshly laundered cloth moistened with plain lukewarm water.

• Grounding (Fig. 16)

For better performance, ground the receiver with ground wire if necessary.

• Hex. Wrench (Fig. 17)

In case the VOLUME, BALANCE, TREBLE, MID, BASS or TUNING control knob comes loose, insert the supplied hex. wrench into the hole on the knob and fasten the screw securely.

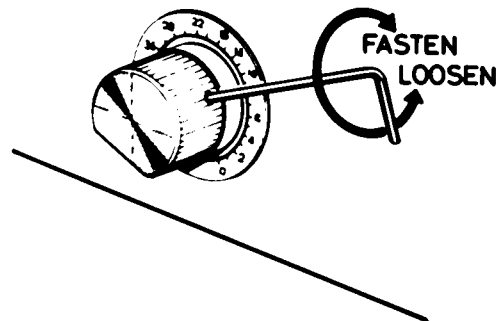

Fig. 17

SPECIFICATIONS

Power Amplifier Section

Continuous minimum sine wave RMS power output per channel at 8 ohms from 20Hz to 20kHz with no more than 0.1% harmonic distortion.

Total harmonic distortion	85 Watts No more than 0.06% (1kHz 1W 8 ohms)
Frequency response	10Hz to 80kHz +0dB -1dB
Input sensitivity/Impedance	1V/50k ohms
Damping factor	50
Hum and noise ratio (IHF, short-circuited A network)	100dB

Pre-Amplifier Section

Input sensitivity and impedance	
Phono 1	2.5mV/50k ohms
Phono 2	2.5mV/50k ohms
Mic.	6.5mV/50k ohms
AUX.	150mV/50k ohms
Tape Play 1	150mV/50k ohms
Tape Play 2	150mV/50k ohms
Tape Play 2 (DIN)	150mV/50k ohms
Total harmonic distortion	No more than 0.06% (1kHz 1V output)
Phono overload level at 0.1% distortion	
Phono 1	300mV
Phono 2	300mV
Output level	
Tape Rec 1	150mV
Tape Rec 2	150mV
Tape Rec 2 (DIN)	30mV/80k ohms
Pre out	1V/2.2k ohms
frequency response	
Phono 1 RIAA 30Hz-15kHz	±0.2dB
Phono 2 RIAA 30Hz-15kHz	±0.2dB
Aux. 20Hz-30kHz	±0.2dB
Tape Play 20Hz-30kHz	±0.2dB
Tone control response	
Bass at 100Hz (T.O.) 400Hz	±10dB
Treble at 10kHz (T.O.) 2.5kHz	±10dB
Mid range at 1kHz	±5dB
Low filter response	30Hz (12dB/oct.)
High filter response	8kHz (6dB/oct.)

Loudness control response

Volume set -30dB position at 100Hz	+10dB
Volume set -30dB position at 10kHz	+4dB
Hum and noise ratio (IHF, short-circuited A network)	
Phono 1	70dB
Phono 2	70dB
Aux.	90dB
Tape Play	90dB

FM Tuner Section

Frequency range	88 - 108MHz
Usable sensitivity	
at Mono	1.8μV (10.3dbf)
Signal-to-noise ratio (at 65dbf)	
at Mono	73dB
at Stereo	68dB
Harmonic distortion (at 65dbf)	
at Mono	0.15%
at Stereo	0.2%
AM suppression (30% 400Hz AM)	60dB
Spurious response	90dB
Alternate channel selectivity	80dB
Image rejection at 90MHz	85dB
IF rejection at 98MHz	100dB
Capture Ratio	1.0dB
Stereo separation at 1kHz	43dB
Muting Threshold	4.5μV
Antenna input	300 ohms balanced 75 ohms unbalanced

AM Tuner Section

Frequency range	525 - 1620kHz
Sensitivity	280μV/m
Signal-to-noise ratio	55dB
Image rejection	65dB
IF rejection	80dB
Selectivity	33dB
Antenna	External ferrite bar antenna

General

Power requirements	AC: 120V, 60Hz
Power consumption	350W
Dimensions	21-11/32" W x 7-3/16" H x 16-9/16" D (540 x 183 x 420 mm)
Weight	Approx. 40 lbs. 13 ozs. (18.5kg)

SPECIFICATIONS ARE SUBJECT TO CHANGE WITHOUT NOTICE.



SANYO ELECTRIC INC.

1200 W. ARTESIA BLVD.

P. O. BOX 5177

COMPTON, CA 90220

Printed in Japan

141-6-410T11000