

# SCHEMATIC DIAGRAM

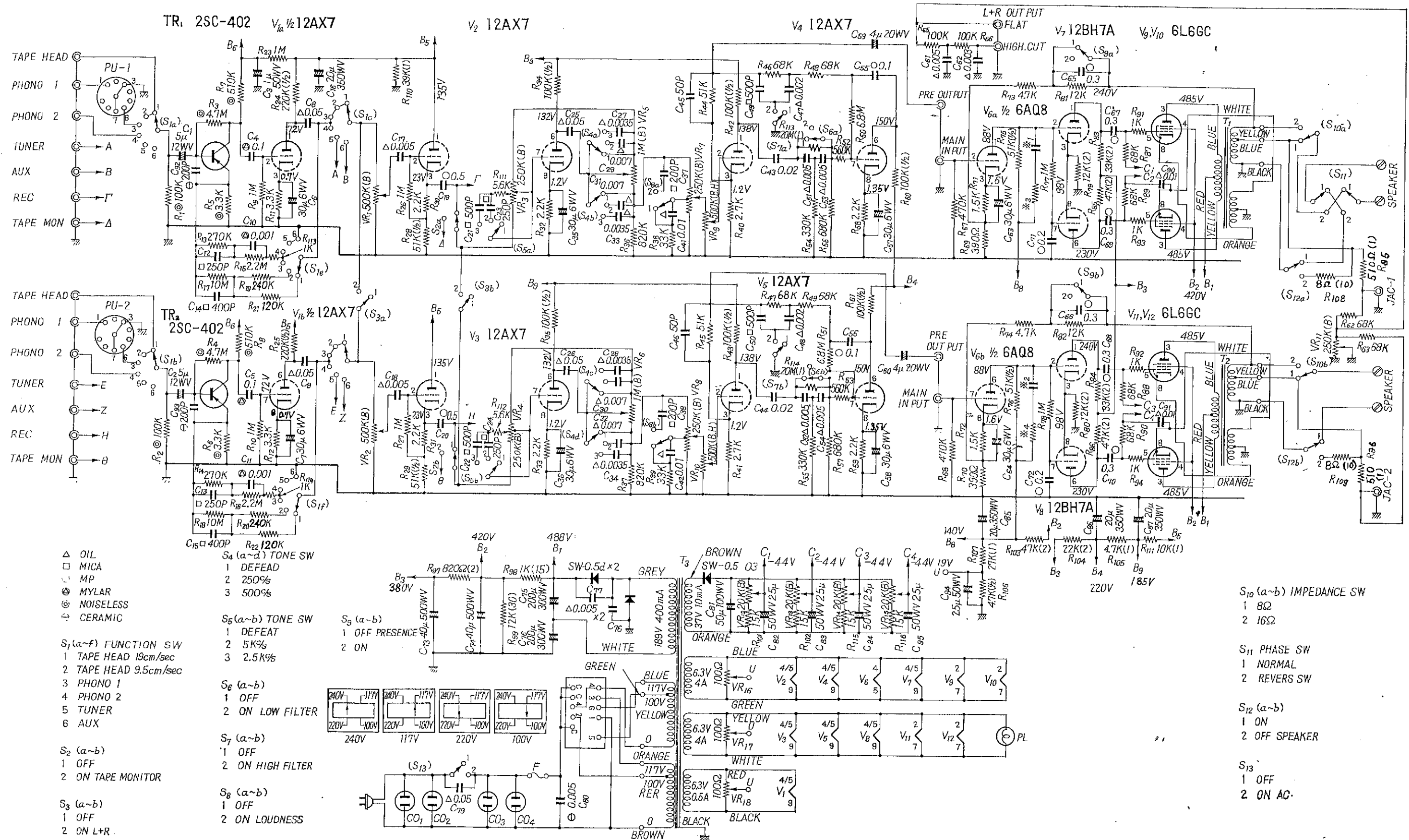

- △ OIL
- MICA
- MP
- ⊙ MYLAR
- ⊙ NOISELESS
- CERAMIC

- S<sub>1</sub>(a-f) FUNCTION SW
- 1 TAPE HEAD 19cm/sec
  - 2 TAPE HEAD 9.5cm/sec
  - 3 PHONO 1
  - 4 PHONO 2
  - 5 TUNER
  - 6 AUX

- S<sub>2</sub>(a-b)
- 1 OFF
  - 2 ON TAPE MONITOR

- S<sub>3</sub>(a-b)
- 1 OFF
  - 2 ON L+R

- S<sub>4</sub>(a-d) TONE SW
- 1 DEFEAD
  - 2 250%
  - 3 500%

- S<sub>5</sub>(a-b) TONE SW
- 1 DEFEAT
  - 2 5K%
  - 3 2.5K%

- S<sub>6</sub>(a-b)
- 1 OFF
  - 2 ON LOW FILTER

- S<sub>7</sub>(a-b)
- 1 OFF
  - 2 ON HIGH FILTER

- S<sub>8</sub>(a-b)
- 1 OFF
  - 2 ON LOUDNESS

- S<sub>9</sub>(a-b)
- 1 OFF PRESENCE
  - 2 ON

- S<sub>10</sub>(a-b) IMPEDANCE SW
- 1 8Ω
  - 2 16Ω

- S<sub>11</sub> PHASE SW
- 1 NORMAL
  - 2 REVERS SW

- S<sub>12</sub>(a-b)
- 1 ON
  - 2 OFF SPEAKER

- S<sub>13</sub>
- 1 OFF
  - 2 ON AC