

OPERATING INSTRUCTIONS & SERVICE MANUAL

AM/FM STEREO RECEIVER

SANSUI 3300



Sansui

SANSUI ELECTRIC CO., LTD.

Congratulations on joining the thousands of proud, satisfied owners of quality stereo components from Sansui, the audio specialist.

In many ways, the 3300 is a culmination of Sansui's long experience and arduous research in the design and manufacture of quality audio equipment. Its tuner section features an FET-equipped sensitive FM frontend and a ceramic filter and IC-equipped FM IF amplifier for exceptional selectivity and superb tonal quality. Its amplifier section is a masterpiece designed, tested and proven to bring out every delicate shade of original sound most faithfully, whatever the program source. In addition, it is equipped with virtually all switches, controls, inputs and outputs that you would ever need to enjoy today's most advanced high fidelity sound reproduction.

So that you can take maximum advantage of its versatility and high performance, may we suggest that you read this manual once carefully? Our past servicing records indicate that most requests for servicing were simply a result of wrong operation. Should you ever encounter an apparent fault of the receiver (such as the absence of sound), please examine the various required connections and your operating procedure once by consulting this manual.

CONTENTS

SWITCHES AND CONTROLS	3, 4
SETTING UP YOUR 3300	5
RADIO RECEPTION	6
PLAYING RECORDS/USING A MICROPHONE	7
UPGRADING YOUR STEREO (4-CHANNEL STEREO SYSTEM/ELECTRONIC CROSSOVER SYSTEM)	8
RECORDING AND PLAYBACK BY TAPE DECKS.....	9, 10
NOISE REDUCTION SYSTEM	11
SIMPLE MAINTENANCE HINTS	12~14
GENERAL TROUBLESHOOTING CHART	15, 16
SPECIFICATIONS	17
SCHEMATIC DIAGRAM	18~21
DISASSEMBLY PROCEDURE	22
TEST POINTS	23
ALIGNMENT	24~26
PRINTED CIRCUIT BOARDS AND PARTS LIST	27~38
OTHER PARTS AND THEIR POSITION ON CHASSIS...	39~40

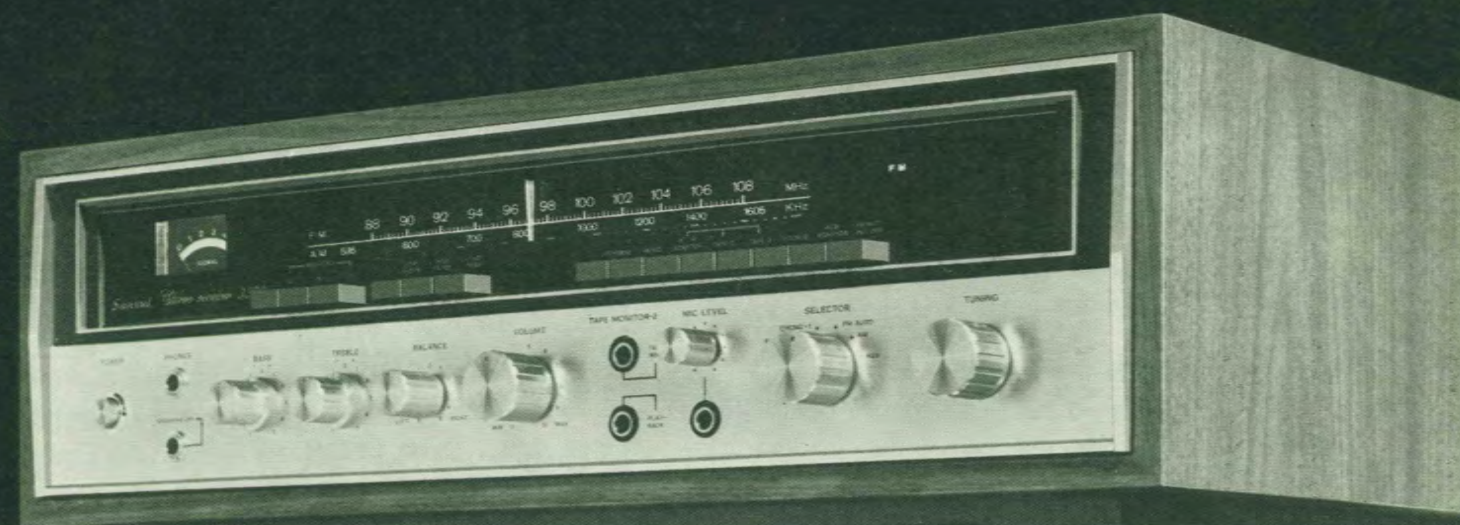

SWITCHES AND CONTROLS

Speaker Selector Buttons

Let you select any pair or a combination of any two pairs of speaker systems out of the three pairs you can connect on the receiver's rear panel. To protect the amplifier, the C pair will not function if you push all three buttons simultaneously.

Signal Meter

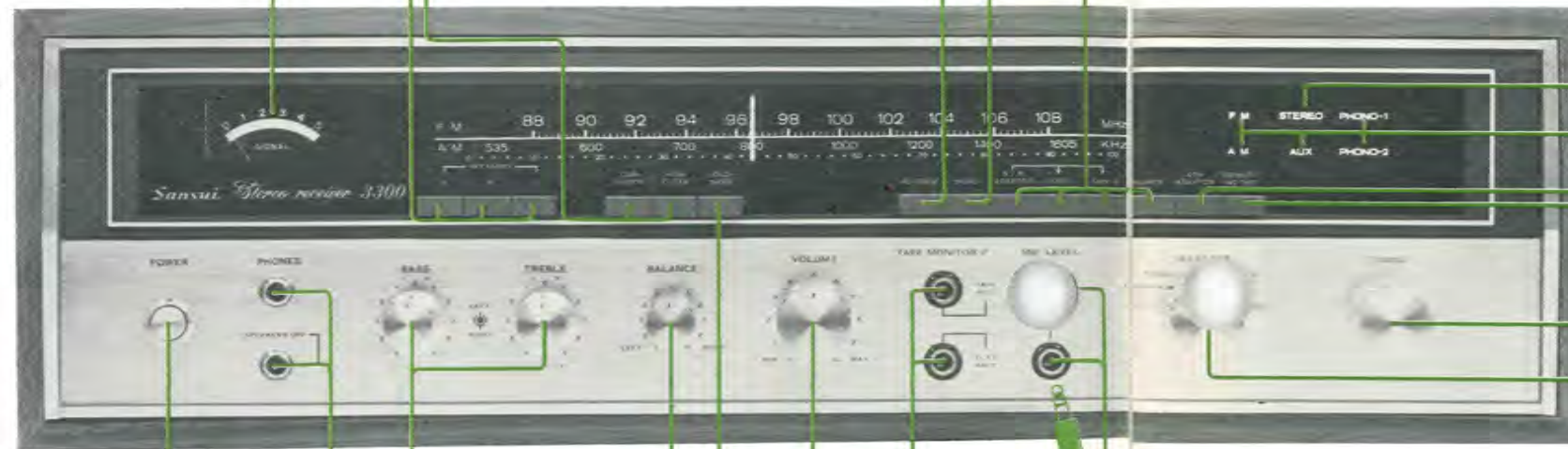

Power Switch

Push it once to turn on power, once more to turn off. It also controls the AC outlet marked SWITCHED on the rear panel.

Headphone Jacks

Accommodate two stereo headphone sets for monitoring or private listening. The upper jack lets you hear reproduced sound both from the speaker systems and the headphone set, while the lower one cuts off the sound from speaker systems so you can listen quietly with headphones only.

Tone Controls

The BASS control adjusts the receiver's low-end response, and the TREBLE control its high-end response. Turn clockwise to emphasize the lows and highs, respectively. On each control, the knob part controls the left channel, while the ring in the back controls the right channel.

Noise Filter Switches

Push the LOW switch to cut off such low-frequency noise as the motor rumble of a turntable, and the HIGH switch to cancel such high-frequency noise as you may hear from a worn record or in a broadcast and any tape hiss. Be sure to keep both switches off if no such noise exists.

Reverse Switch

Push to reverse the left and right channel signals during stereo operation.

Balance Control

Loudness Switch

If desired, push to emphasize the highs and lows when listening at low volume levels. The mechanism of human hearing is such that the high and low notes seem greatly enfeebled at low listening levels.

TAPE MONITOR-2 Jacks

Part of the same second tape record/playback circuit that gives the TAPE-2 pin jack terminals on the rear panel, these jacks let you connect a tape deck on the front panel. To record into a tape deck, connect to the TAPE REC jack. To reproduce, connect to the PLAYBACK jack. Push the TAPE-2 button to reproduce a recorded tape or monitor a recording as you make it on a tape deck so connected.

Volume Control

Mono Switch

Push to hear in mono whatever program source you may have set the receiver to reproduce.

Tape Monitor Switches

Push the TAPE-1 or TAPE-2 tape monitor switch to monitor or reproduce a recording on a tape deck.

See page 11 for explanations of the N.R. ADAPTOR and SOURCE Switches.

Microphone Jack and Volume Control

Insert a microphone into the jack, then adjust its sound volume with this specialized volume control. You can mix the sound from the microphone with any of the program sources chosen on the Selector Control. The over-all sound volume so mixed can then be controlled with the Volume Control.



FM Stereo Indicator

Illuminates when the set is tuned in on an FM station broadcasting in stereo.

Function Indicators

4-Channel Adaptor Switch

If you connect a 4-channel adaptor to the 3300 and make other necessary connections, you will be able to upgrade this 2-channel stereo receiver to hear 4-channel stereo sound by pushing this switch (refer to page 8). Otherwise, be sure to keep it off.

FM Muting Release Switch

The built-in FM muting circuit is constantly at work to eliminate the inter-station noise commonly heard during FM tuning. Use this switch to cancel that circuit when you are trying to tune in a weak station.

Tuning Knob

Selector Control

Turn to an appropriate position to hear the desired program source.

PHONO-2: Selects the turntable connected to the PHONO 2 inputs on the rear panel.

PHONO-1: Selects the turntable connected to the PHONO 1 inputs.

FM AUTO: To hear FM broadcasts, whether stereo or mono. When the broadcast signal changes from mono to stereo, the receiver automatically switches to stereo reception. The FM Stereo Indicator will then glow in red to indicate the condition.

AM: To hear regular AM (MW) broadcasts.

AUX: To reproduce whatever program source is connected to the AUX inputs on the rear panel. (Connect a crystal or ceramic cartridge or the audio outputs of a TV set to the AUX inputs.)

SETTING UP YOUR 3300

Before you insert the 3300's power cord into a wall AC outlet, be sure to make the following preparation.

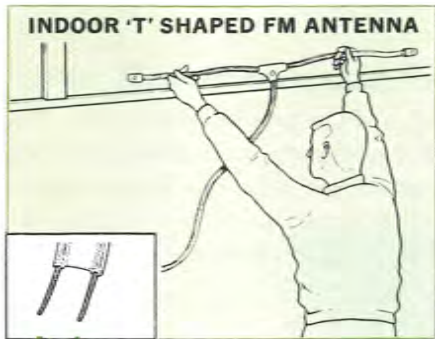

FM Antenna: Connect the T-shaped feeder cable antenna supplied to the receiver's FM-300Ω terminals. Adjust the receiver for FM reception and stretch the antenna to a full 'T' shape, then change its height and direction until the best reception is obtained.

AM Bar Antenna: AM reception is obtained simply by pulling the built-in AM ferrite bar antenna away from the set.

Speaker Systems: Connect your speaker systems to the SPEAKERS terminals on the receiver's rear panel, taking care not to confuse the left and right, plus and minus terminals on both ends. Should you wish to drive two pairs of speaker systems simultaneously, they should all have an impedance of 8 ohms or more.

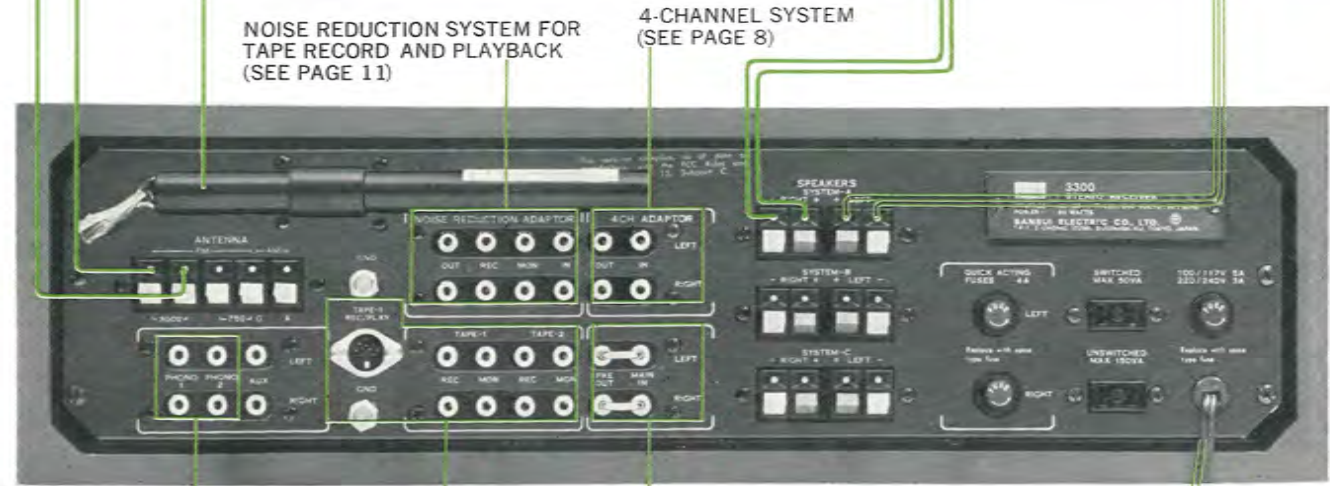
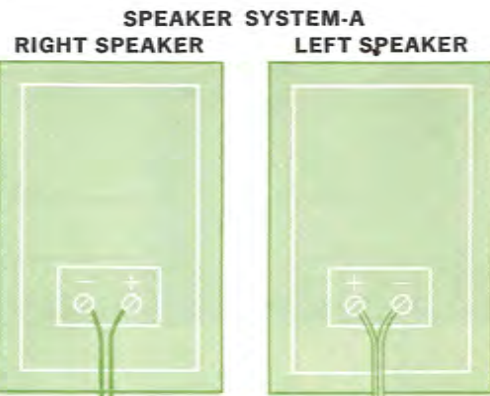

RADIO RECEPTION

FM/AM Reception

1. Turn the Selector Control to FM AUTO or AM, whichever you may wish to hear.
2. Select the desired FM or AM station by turning the Tuning Control. The station is correctly tuned in when the Signal Meter pointer has swung as far to the right as possible.

If the FM station received is broadcasting in stereo, the FM Stereo Indicator will illuminate.

For Better FM/AM Reception

In areas remote from broadcast stations or blocked by such obstacles as mountains and large buildings, the T-shaped feeder cable FM antenna and built-in AM ferrite bar antenna alone may sometimes fail to give you sufficiently clear reception. If this happens, resort to the following measures.

Outdoor FM Antenna

Install a commercially available FM outdoor antenna with at least five to seven elements. While such antenna may be connected to the receiver either with 300-ohm balanced feeder cable or 75-ohm unbalanced coaxial cable (see illustration), the use of the latter is recommended because of its better signal transmission capability, if your budget allows. In addition, an impedance matching transformer may be sometimes required, and this should be found out at the time of purchase. After connecting the antenna, adjust its direction so as to obtain the best reception while actually listening to your favorite FM station.

Outdoor AM Antenna

Connect the polyvinyl wire supplied to the AM-A antenna terminal on the receiver's rear panel, then extend it outside a window or on the roof.

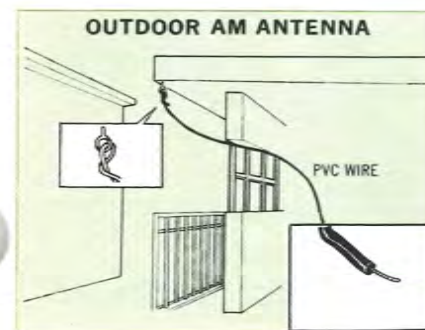
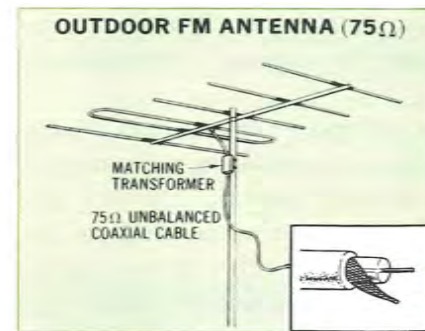
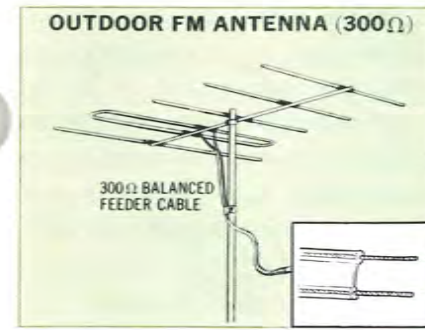

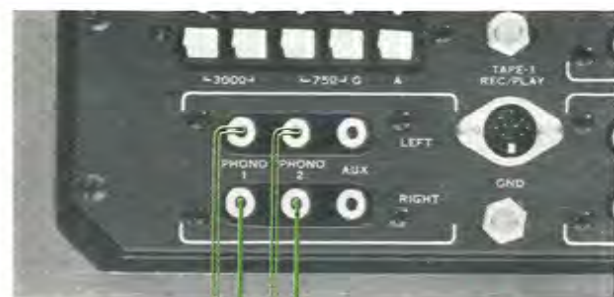

TURNTABLE (2)



TURNTABLE (1)

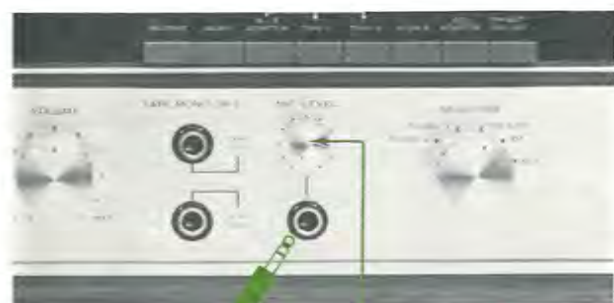

MIC LEVEL CONTROL



MICROPHONE (High Impedance)

Connecting Turntables

As your 3300 is equipped with two phono input circuits, you may connect two turntables or employ two different tonearms. These turntables or tonearms should each be equipped with a magnetic cartridge.

Playing Records

1. Set the Selector Control to PHONO-1 or PHONO-2, depending on which input circuit you are using.
2. Switch on the turntable, adjusting it for the right speed of the record to be played.
3. Start playing the record.
4. Use the various controls and switches on your 3300 to suit your personal taste and room acoustics.

Using a Microphone

Connect a high-impedance ($10k\Omega$ or more) microphone to the microphone jack on the receiver's front panel. You can mix the sound picked up by the microphone with any program source selected on the Selector Control, and hear the mixture out of the speaker systems and/or record it into a tape deck. The sound volume is adjusted with the MIC LEVEL Control and Volume Control.

Caution:

1. If you wish to use a low-impedance (e.g., 600Ω) microphone, connect it to the receiver via an impedance matching transformer (commercially available).
2. If you raise the microphone volume in an acoustically reflective room, loud oscillating noise may be emitted from the speaker systems. This is a phenomenon called howling and is no fault of the receiver. It can be corrected either by lowering the volume with the MIC LEVEL Control, directing or moving the microphone away from the speaker systems.

4-Channel Stereo System

The sound we daily hear is a mixture of the sound that reaches your ears straight from the sound source—be it a musical instrument, a jet, a man's mouth or what have you—and the 'indirect sounds' that arrive at your ears only after they are reflected off various surfaces, such as walls, ceiling and so forth.

Four-channel recordings are made using two microphones in the front of the concert hall and two in the rear (to simplify the explanation). The 'indirect sounds' with their complicated waveforms are mainly picked up by the two microphones in the rear, and reproduced out of the two rear speakers in a 4-channel stereo set-up for greatly enhanced 'ambience' effects. The effect is almost as if the original live performance were re-played right in your own room.

This new approach can now be yours simply by adding certain equipment—mainly, a Sansui 4-channel rear amplifier and a second pair of speaker systems—to your 2-channel stereo system.

Connection of such a rear amplifier or 4-channel adaptor is easy. Just connect the 4CH ADAPTOR OUT terminals of your 3300 with the input terminals of such rear amplifier or 4-channel adaptor, then connect its 4CH ADAPTOR IN terminals with the output terminals of such unit.

To operate the rear amplifier or 4-channel adaptor so connected, push the 4CH ADAPTOR Switch on the receiver's front panel, and otherwise follow its manufacturer's instructions. Electrically, the 4CH ADAPTOR OUT and IN terminals possess the same functions as the TAPE REC and MON terminals, respectively.

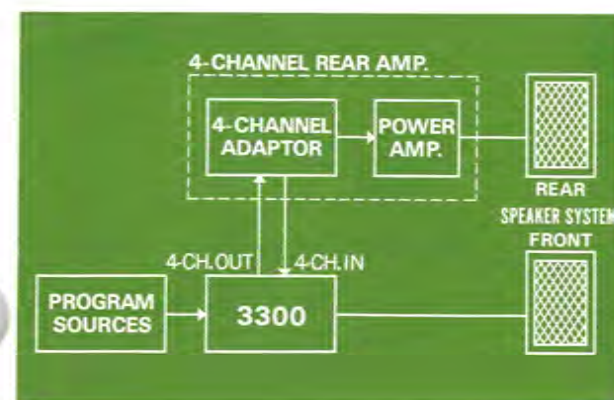

Electronic Crossover System

The electronic crossover system is recognized by many audiophiles as a means of maximally enhancing the fidelity of reproduced sound, for these reasons:

1. It enables the tweeters, midranges and woofers to be driven by separate power amplifiers. So you can make optimum use of speakers of different impedances and efficiencies, and power amplifiers with different output capacities and tone qualities.
2. It eliminates the need for the conventional LC type crossover network. With the electronic crossover divider, the amplifier's damping factor is no longer affected and you can set crossover frequencies as you like.

Electronic Crossover System Using the 3300

The preamplifier and power amplifier sections of your 3300 can be disconnected for independent usage, the latter section being available for driving a separate speaker in an electronic crossover system. To build such a system, you will need an electronic crossover unit, and at least one or two additional power amplifiers (depending on whether your speaker systems are two-way or three-way).

Connection is not all that difficult. First remove the Pre-Main Connectors uniting your 3300's preamplifier outputs and power amplifier inputs. Then just connect the preamplifier outputs to the input terminals of the electronic crossover unit, which divides the input signals into high, medium and low range(s) (or channels). Finally, couple the receiver's power amplifier inputs and the additional power amplifier(s) to the separate output terminals of the electronic crossover unit, feeding their outputs separately into individual speakers, as illustrated below.

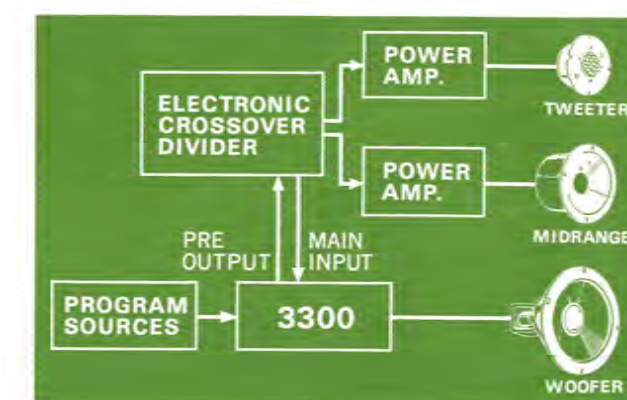

RECORDING AND PLAYBACK BY TAPE DECKS

Connecting Tape Decks

Your 3300 is provided with the following facilities for tape recording and playback:

For a first tape deck

Recording: TAPE-1 REC pin jacks on the receiver's rear panel.

Playback: TAPE-1 MON pin jacks on the same rear panel.

Recording & playback: TAPE-1 REC/PLAY DIN socket, also on the rear panel.

(The REC and MON pin jacks and the DIN socket must not be used simultaneously.)

For a second tape deck

Recording: TAPE-2 REC pin jacks on the receiver's rear panel, or TAPE MONITOR-2 TAPE REC phone jack on its front panel.

Playback: TAPE-2 MON pin jacks on the rear panel, or TAPE MONITOR-2 PLAYBACK phone jack on the front panel.

(Connecting a tape deck to the front-panel TAPE MONITOR-2 phone jacks automatically disables the rear panel TAPE-2 pin jacks.)

For a third tape deck

Recording: 4CH ADAPTOR OUT or NOISE REDUCTION ADAPTOR OUT pin jacks

Playback: 4CH ADAPTOR IN or NOISE REDUCTION ADAPTOR IN pin jacks

Recording by a Tape Deck

1. Set the receiver's Selector Control to the program source you wish to record. Use a microphone if necessary.

2. Start the tape deck in the recording mode.

3. To monitor the sound being recorded, push the receiver's TAPE-1 or TAPE-2 tape monitor switch, whichever circuit is accommodating the tape deck you are using.

Playback by a Tape Deck

1. Push the receiver's TAPE-1 or TAPE-2 tape monitor switch, whichever circuit is accommodating the tape deck you are using.

2. Start the tape deck in the playback mode.

3. Use the various controls and switches on the receiver to suit your personal taste and room acoustics.

Recording from One Tape Deck into Another

It is suggested that you use the tape deck connected to the TAPE-1 circuit for playback, and the one connected to the TAPE-2 circuit for recording. To record from the first tape deck into the second, proceed as follows:

1. Push the TAPE-1 tape monitor switch of the receiver.
2. Start the second tape deck in the recording mode.
3. Now start the first tape deck in the playback mode.

Note:

1. To reproduce a recorded tape on a tape deck connected to the TAPE-1 pin jacks on the receiver's rear panel, push the TAPE-1 tape monitor switch



DIN CABLE

RECORD
PLAYBACK

TAPE DECK (1)

NOTE: Do not use the TAPE-1 REC/PLAY terminals and DIN Connector Socket simultaneously.

on the front panel. Similarly, if you use the TAPE-2 or 4CH ADAPTOR or NOISE REDUCTION ADAPTOR jacks, push the corresponding switch on the front panel to obtain the playback function.

2. To 'monitor' a recording means to reproduce a recording as you make it to check on the quality of the recorded sound. This is only possible if the tape deck is equipped with separate erase, record and playback heads.

3. The DIN socket marked TAPE-1 REC/PLAY on the rear panel combines both the recording and playback terminals, and can be used only if your tape deck is equipped with an identical socket.

4. The SOURCE switch on the receiver's front panel is for use when you connect a noise reduction adaptor to the receiver (see page 11).

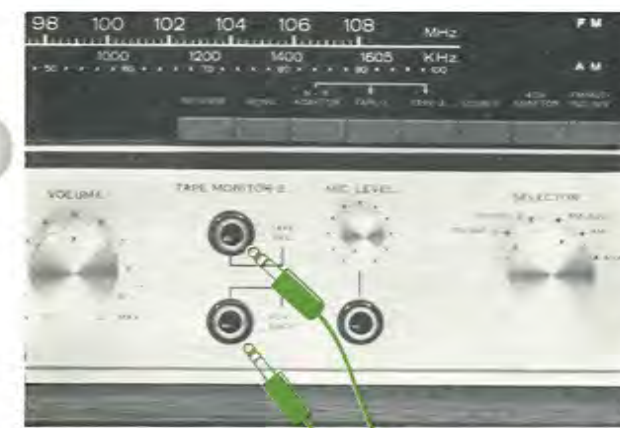

PLAYBACK RECORD

TAPE DECK (2)

NOTE: Do not use the TAPE MONITOR-2 TAPE REC, PLAYBACK phone jacks and TAPE-2 REC/MON pin jacks simultaneously.

Noise Reduction System

A noise reduction system, as its name indicates, is designed to reduce various types of noise commonly generated during tape recording or playback. The most annoying of such noise is the so-called tape hiss, which is heard over the entire audio spectrum of recorded sound and which is almost inherent in tape recording.

While different kinds of noise reduction system have been proposed by different manufacturers, they are almost always designed to dilute this unpleasant tape hiss. The most recent innovation in this field is called the Dolby Noise Reduction System, which already seems to have won worldwide recognition as one of the most effective yet devised.

As tape hiss and other types of noise invariably increase in quantity as the tape speed slows down, the effect of reducing noise by a noise reduction adaptor is particularly great when such adaptor is incorporated into a cassette tape deck.

Construction of a Noise Reduction System

Output signals delivered at the receiver or amplifier's tape recording terminals are fed through the recording noise reduction unit in a noise reduction adaptor (abbreviated as n.r. adaptor hereafter), then recorded into a tape by a tape deck. For playback, the output signals given at the tape deck's playback or output terminals are fed through the playback noise reduction unit of the adaptor and into the receiver or amplifier's tape monitor or input terminals. A block diagram of a typical noise reduction system is presented below.

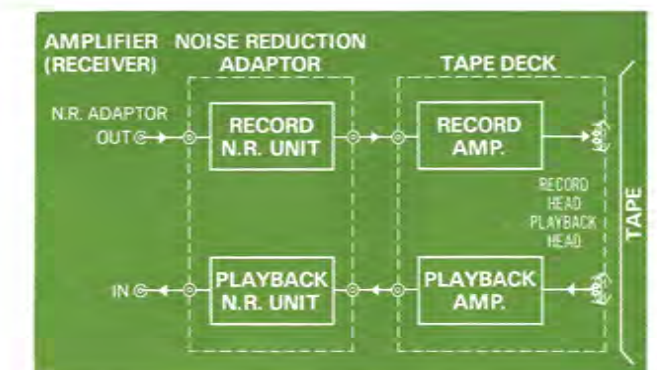

Connecting a Noise Reduction Adaptor

A n.r. adaptor is normally connected to both an amplifier or receiver and a tape deck.

In the case of your 3300, however, merely connect such adaptor to the receiver. The tape decks connected to the receiver's TAPE-1 and/or TAPE-2 terminals can then be made to assume noise reduction effects simply by pushing the N.R. ADAPTOR Switch on the receiver's front panel. When reproducing, push the appropriate tape monitor switch.

The four pairs of N.R. ADAPTER jacks on your 3300's rear panel have functions as explained below. Make correct connections by referring to the operating instructions supplied by the manufacturer of your n.r. adaptor.

OUT: Possess the same function as the receiver's recording (output) terminals.

Connect these jacks with the inputs of your n.r. adaptor so those signals will flow into that unit.

REC: Connect these jacks with the recording outputs of the n.r. adaptor. (Usually, connections are made between the recording outputs of the n.r. adaptor and the recording (input) jacks of a tape deck, instead.)

MON: Connect these jacks with the playback inputs of the n.r. adaptor. (This connection replaces the one usually made between the playback inputs of the adaptor and the playback (output) jacks of the tape deck.)

IN: Possess the same function as the receiver's monitor or playback (input) terminals.

Connect these jacks with the outputs of the adaptor, so those signals will be properly amplified by the receiver for reproduction out of speaker systems.



Recording through a N.R. Adaptor

1. Set the receiver's Selector Control to the program source you want to record. Or use a microphone and/or appropriate tape monitor switch as needed.

2. Push the receiver's N.R. ADAPTOR Switch.

3. Engage your n.r. adaptor in the recording mode.

4. Start the tape deck in the recording mode.

5. To monitor the sound being recorded, push the receiver's TAPE-1 or TAPE-2 tape monitor switch, whichever circuit is accommodating the tape deck you are using.

Note:

1. To monitor the sound you are recording on a two-head tape deck (with a combined record/play head) and/or a single-circuit n.r. adaptor (with a combined record/playback n.r. unit), or to compare that sound with the original before recording sound, push the SOURCE Switch on the front panel.

2. If you want to copy an already recorded tape from one tape deck into another via your n.r. adaptor, connect the playback (output) jacks of the first (used for playback) tape deck to the receiver's AUX jacks, then turn the receiver's Selector Control to AUX. Then merely follow steps 2 to 5 explained above.

Playback through a N.R. Adaptor

1. Push the receiver's TAPE-1 or TAPE-2 tape monitor switch, whichever circuit is accommodating the tape deck you are using.

2. Push the receiver's N.R. ADAPTOR Switch.

3. Engage your n.r. adaptor in the playback mode.

4. Start the tape deck in the playback mode.

NOISE REDUCTION ADAPTOR

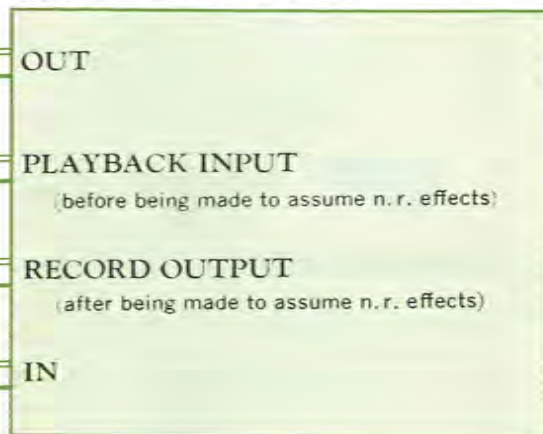

Quick Check List of Wrong Operations

If you have already confirmed that all the connections are correct and completely made, but if no sound is still heard from the speaker systems, go down the check list below once to see if you haven't made any of these simple mistakes:

1. Have you turned on the Power Switch?

2. Have you turned the Selector Control to the desired function?

3. Have you pushed the correct Speaker Selector Button(s)?

4. Are the Tape Monitor Switch(es) or N.R. ADAPTOR Switch not pushed down, though you don't want to reproduce a tape?

5. Is the 4CH ADAPTOR Switch not pushed down, though you are not using a 4-channel rear amplifier or adaptor?

6. Is the Volume Control properly turned up?

Rear-Panel AC Outlets

Of the two AC outlets provided on the rear panel, the one marked 'SWITCHED' is controlled by the front-panel Power Switch. The other, marked 'UNSWITCHED', is always 'live' and independent of the Power Switch. They have a power capacity of 50VA and 150VA respectively, and it is extremely dangerous to connect equipment with bigger power requirements. Before connecting any equipment to either outlet, make certain its power requirement does not exceed its power capacity limit. The voltage supplied at these AC outlets is the same as the power supply voltage used.



About the Place of Installation

The wooden cabinet of the 3300 is designed so that any heat radiated inside will effectively escape through it. Proper care should therefore be taken of the dissipation of such heat if you wish to place something on top of the receiver or place it inside a closed box, etc. Above all, avoid placing it where it may be exposed to direct sunlight.

Howling and Hum

Take care never to place a turntable on or too near a speaker system, or the vibration produced by the speaker system is transmitted and causes an oscillating phenomenon called howling. It is best to keep these components completely separated, but if this is impossible, place a thick cushion between them.

Humming, in contrast, is a phenomenon caused by incomplete or incorrect turntable-receiver connections. Should this occur, check to see if all connections are completely made and if the connecting wires are sufficiently thick. Hum noise may sometimes be eliminated by connecting the grounding lead of the turntable to the GND terminal on the rear panel of your 3300.

When Connecting a Turntable, etc.

To connect a turntable, tape deck and so forth, it is strongly recommended to use thick, shielded cables with minimal distributed capacitance and to keep them as short as possible.

To solder the pin plugs supplied as accessories onto such shield cables, refer to the illustration below.

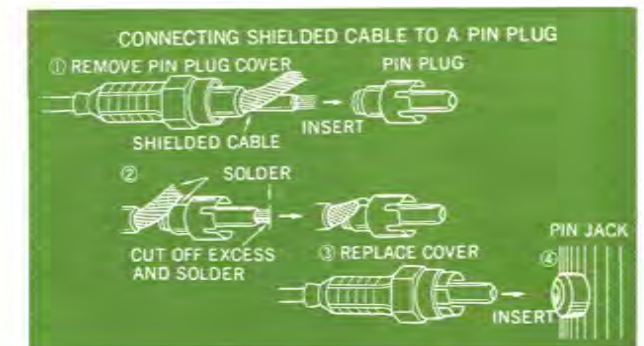

SIMPLE MAINTENANCE HINTS

Should the Power Fuse Blow

If no Selector Indicator should glow and the receiver simply remains dead even after you have turned on its Power Switch, it is possible that its power fuse has blown. If this happens, disconnect the power cord from the wall AC outlet at once and examine the power fuse on the receiver's rear panel. If you find it blown, replace it with a new glass-tubed fuse of the rated capacity. Never use a fuse of a different capacity or a piece of wire, even as a stop-gap measure, or serious danger could result.



About the Quick-Acting Fuses

When a Selector Indicator is glowing, if no sound comes out of either or both of the speaker systems, examine their connections and your operating procedure once. If nothing is wrong with them, it is possible that the quick-acting fuse or fuses protecting the power transistors have blown. If this should happen, disconnect the power cord from the wall AC outlet immediately and check the four quick-acting fuses on the rear panel. If you find any of them blown, discover and eliminate the cause of the blowout, then replace it with a new 4-ampere quick-acting fuse supplied. Probable causes of the blowout include excessively large input signals and a short-circuit at the speaker terminals.



Grounding

Any noise picked up by the connecting cables can be effectively grounded by connecting a piece of PVC (polyvinyl chloride) or enameled wire to the GND terminal on your receiver's rear panel, attaching a small copper plate or carbon rod to the other end and burying it deep underground. The grounding leads of other equipment in your stereo system may be connected to the same terminal to ground the entire system at once.

If you have connected an external AM antenna to the receiver, it is advisable to ground it as well.

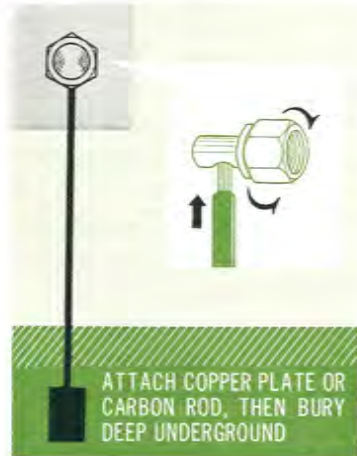

Voltage Adjustment

Your 3300 is adjusted to operate at the correct power supply voltage of your area prior to shipment from our factory. If you move after purchasing it or send it as a gift to a friend living in an area where the voltage is different, it may be necessary to adjust its Voltage Selector. To adjust it, remove the two screws securing the name plate on the receiver's rear panel, then set the arrow mark on the Voltage Selector Plug to the correct voltage indication (100, 117, 220 or 240 volts).

Also, it may be necessary to replace the power fuse as well whenever the voltage has changed. For operation at 100-117 volts, use a 5-ampere fuse. For operation at 220-240 volts, use a 3-ampere one.



117V (POWER FUSE 5A)

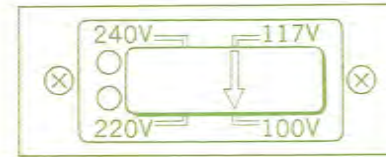

100V (5A)

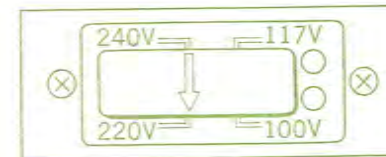

220V (3A)

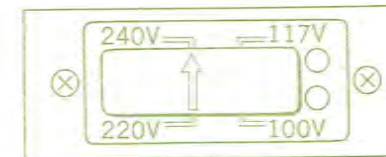

240V (3A)

About Servicing

Should anything ever go wrong with your 3300, or if you have any question about it, please contact the Sansui dealer from whom you purchased it or your nearest Authorized Sansui Service Station.

Accessory List

1. FM ANTENNA	1
2. AM ANTENNA	1
3. PIN PLUGS	4
4. BUTTERFLY BOLTS	2
5. WASHERS	2
6. POLISHING CLOTH	1
7. QUICK-ACTING FUSES (4A)	2
8. OPERATING INSTRUCTIONS AND SERVICE MANUAL	1
9. OPERATING INSTRUCTIONS SHEET	1

GENERAL TROUBLESHOOTING CHART

If the receiver is otherwise operating satisfactory, the more common causes of trouble may generally be attributed to the following:

1. Incorrect connections or loose terminal contacts. Check the speakers, turntable, tape deck, antenna and power cord.
2. Improper operation. Before operating any audio com-

ponent, be sure to read its manufacturer's instructions.

3. Improper location of audio components. The proper positioning of components, such as speakers and turntable, is essential to maximum stereo enjoyment.

4. Defective audio components.

The chart below lists some other common causes of malfunction and what to do about them.

PROGRAM	SYMPTOM	PROBABLE CAUSE	WHAT TO DO
AM, FM or MPX reception	A. Constant or intermittent noise heard at times or in certain areas	* Discharge or oscillation caused by electrical appliances, such as fluorescent lamp, TV set, D.C. motor rectifier or oscillator	* Attach noise limiter to electrical appliance producing noise, or attach it to receiver's power source
		* Natural phenomena, such as atmospherics, statics or thunderbolts	* Install outdoor antenna and ground receiver to raise S/N ratio
		* Insufficient antenna input due to ferroconcrete wall or long distance from station	* Reverse power cord plug/receptacle connections * If noise occurs at certain frequency, attach wave trap to input * Keep receiver at proper distance from other electrical appliances
AM reception	A. Noise heard at particular time of day, in certain area or over part of dial	* Peculiar to AM broadcasts	* Install antenna for maximum antenna efficiency. See RADIO RECEPTION in operating instructions booklet * In some cases, noise can be eliminated by grounding receiver or reversing power cord plug/receptacle connections
	B. High-frequency noise	* Interference by adjacent stations or beat interference * TV set too close to stereo system	* Such noise cannot be completely eliminated by adjusting receiver, but it is advisable to turn Treble Control counterclockwise, or turn on High Filter * Keep TV set at proper distance from stereo system
FM reception	A. Noisy	* Poor noise limiter effect or too low S/N ratio due to insufficient antenna input	* Install FM antenna (supplied) for maximum signal strength * If this does not prove effective, use exclusive FM outdoor antenna. If using TV antenna for both TV and FM with divider, make sure TV reception is not affected * Excessively long lead-in wire of antenna may cause noise
		Note: FM reception is affected considerably by transmission conditions of station, such as power and antenna efficiency. So you may receive one station quite well while receiving another station poorly	
		B. Series of pop noise	* Ignition noise caused by starting of nearby automobile engine
	C. Tuning noise between stations	* Results from nature of FM reception * FM Muting Release switch depressed	* Release FM Muting Release switch * Ditto

PROGRAM	SYMPTOM	PROBABLE CAUSE	WHAT TO DO
FM-MPX reception	A. Noise heard during FM-MPX reception but inaudible during FM mono reception	* Weaker signal because service area of FM-MPX broadcast is only half that of FM mono broadcast	* Orient antenna for maximum antenna input * Switch on High Filter and/or turn Treble Control counterclockwise
	B. Channel separation deteriorates during reception	* Excessive heat	* Circulation of room air is important. Be sure through receiver is well ventilated
	C. Stereo indicator blinks on and off	* Interference	* Indicator is not faulty; adjust VR ₄₀₂
Record playing or tape playback	A. Hum or howling	* Turntable placed directly on speaker * Wire other than shielded cable used * Loose terminal contact * Shielded cable too close to power cord, fluorescent lamp or other appliances * Nearby amateur radio station or TV transmission antenna	* Place cushion between turntable and speaker cabinet or place them away from each other * Connecting shielded cables should be as short as possible * Turn on Low Filter and turn Bass Control counterclockwise * Consult nearest governmental or municipal office regulating use of radio waves
		B. Surface noise	* Worn or old record * Worn phono stylus * Phono stylus is dusty * Improper stylus pressure

SPECIFICATIONS

AMPLIFIER SECTION

POWER OUTPUT

IHF MUSIC POWER: 165W (4 Ω) at 1,000Hz
110W (8 Ω) at 1,000Hz

CONTINUOUS RMS POWER (each channel driven):
65/65W (4 Ω) at 1,000Hz
45/45W (8 Ω) at 1,000Hz

CONTINUOUS RMS POWER (both channels driven):
36+36W (8 Ω) at 1,000Hz

CONTINUOUS RMS POWER (both channels driven
at rated distortion, 20 to 20,000Hz): 28+28W (8 Ω)

TOTAL HARMONIC DISTORTION

POWER AMP. ONLY: less than 0.4% at rated output

PRE-AMP. ONLY (PHONO to pre output):
less than 0.5% at rated output
(AUX to pre output):

less than 0.2% at rated output

OVER-ALL (PHONO to power output):
less than 0.4% at rated output

INTERMODULATION DISTORTION

(60Hz: 7,000Hz=4:1 SMPTE method)

(AUX to power output):
less than 0.4% at rated output
(Power amp. only): less than 0.4% at rated output

POWER BANDWIDTH (IHF): 15 to 35,000Hz

FREQUENCY RESPONSE

OVER-ALL (AUX to power output):
20 to 40,000Hz +1dB, -2dB

POWER AMP. ONLY: 20 to 40,000Hz +0.5dB, -1.5dB

LOAD IMPEDANCE: 4 to 16 ohms

DAMPING FACTOR: Approximately 30 at 8 Ω load

CHANNEL SEPARATION: (at rated output, 1,000Hz)

PHONO OVER-ALL: better than 50dB

AUX OVER-ALL: better than 50dB

POWER AMP ONLY: better than 60dB

HUM AND NOISE (IHF)

PHONO: better than 70dB

AUX: better than 80dB

POWER AMP. ONLY: better than 90dB

INPUT SENSITIVITY: (at rated output, 1,000Hz)

PHONO: 2.5mV (50k ohms)

AUX: 150mV (50k ohms)

MIC: 4mV (10k ohms)

TAPE MONITOR (Pin) (DIN): 150mV (50k ohms)

NOISE REDUCTION ADAPTOR: 150mV (50k ohms)

4-CH ADAPTOR: 150mV (50k ohms)

POWER AMP. INPUT: 800mV (100k ohms)

OUTPUT

TAPE REC (Pin): 150mV (50k ohms)

(DIN): 30mV (100k ohms)

PRE-AMP. OUTPUT: 800mV (100k ohms)

MAX: 4V

TONE CONTROLS

BASS: +12dB, -12dB at 50Hz

TREBLE: +12dB, -12dB at 10kHz

FILTERS

LOW FILTER: -10dB, at 50Hz (6dB/oct)

HIGH FILTER: -10dB, at 10kHz (6dB/oct)

LOUDNESS: +10dB at 50Hz, +8dB at 10kHz

FM TUNER SECTION

TUNING RANGE: 88 to 108MHz

SENSITIVITY (IHF): 1.9 μ V

SIGNAL TO NOISE RATIO: better than 63dB

IMAGE REJECTION: better than 75dB at 98MHz

SPURIOUS RESPONSE REJECTION:

better than 90dB

SELECTIVITY: better than 60dB

IF REJECTION: better than 80dB

CAPTURE RATIO: better than 2dB

TOTAL HARMONIC DISTORTION

MONO: less than 0.5%

STEREO: less than 0.8%

FM STEREO SEPARATION: better than 35dB

ANTENNA INPUT IMPEDANCE:

300 ohms balanced, 75 ohms unbalanced

AM TUNER SECTION

TUNING RANGE: 535 to 1,605kHz

SENSITIVITY (bar antenna): 50dB/m at 1,000kHz

SELECTIVITY (\pm 10kHz): better than 20dB

IMAGE FREQUENCY REJECTION:

better than 80dB/m at 1,000kHz

IF REJECTION: better than 80dB/m at 1,000kHz

GENERAL

TAPE MONITOR 1, 2: OFF/ON

N.R. ADAPTOR: OUT/IN

SOURCE: OFF/ON

LOUDNESS: OFF/ON

FILTERS (HIGH, LOW): OFF/ON

MODE: STEREO/MONO

REVERSE: NORMAL/REVERSE

FM MUTING: ON/OFF

SPEAKERS A,B,C: OFF/ON

SELECTOR: PHONO-2/PHONO-1/

FM AUTO/AM/AUX

SEMICONDUCTORS: Transistors: 58 FET: 3

Diodes: 20 ZD: 2 IC: 1

POWER REQUIREMENTS

POWER VOLTAGE: 100V, 117V, 220V, 240V

POWER CONSUMPTION: 400VA (max.) 90Watts (rated)

DIMENSIONS: 486.5mm (19 $\frac{3}{16}$ " W,

147mm (5 $\frac{3}{16}$ " H,

355mm (14" D

WEIGHT: 16.7kg (36.8 lbs.)

SCHEMATIC DIAGRAM OF AMPLIFIER SECTION

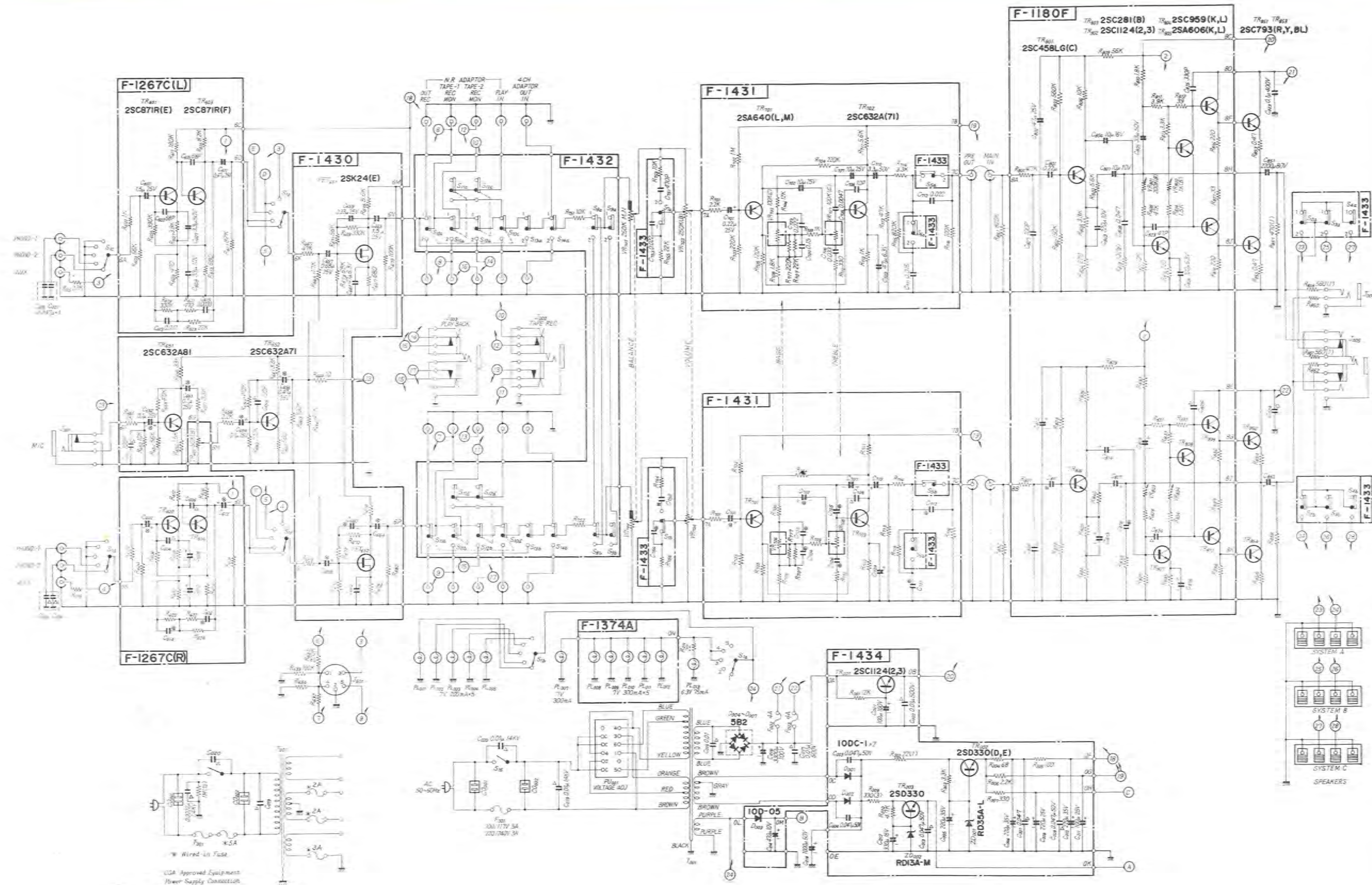

SCHEMATIC DIAGRAM OF TUNER SECTION

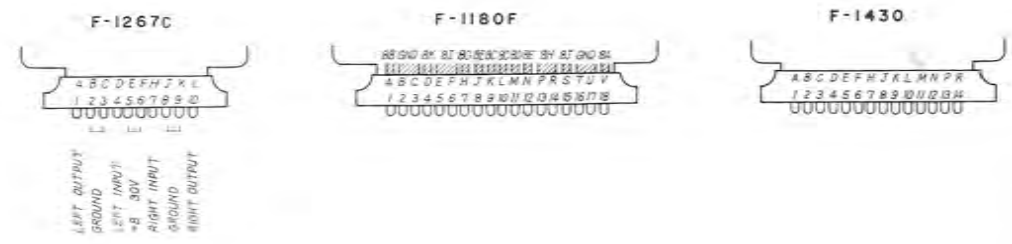
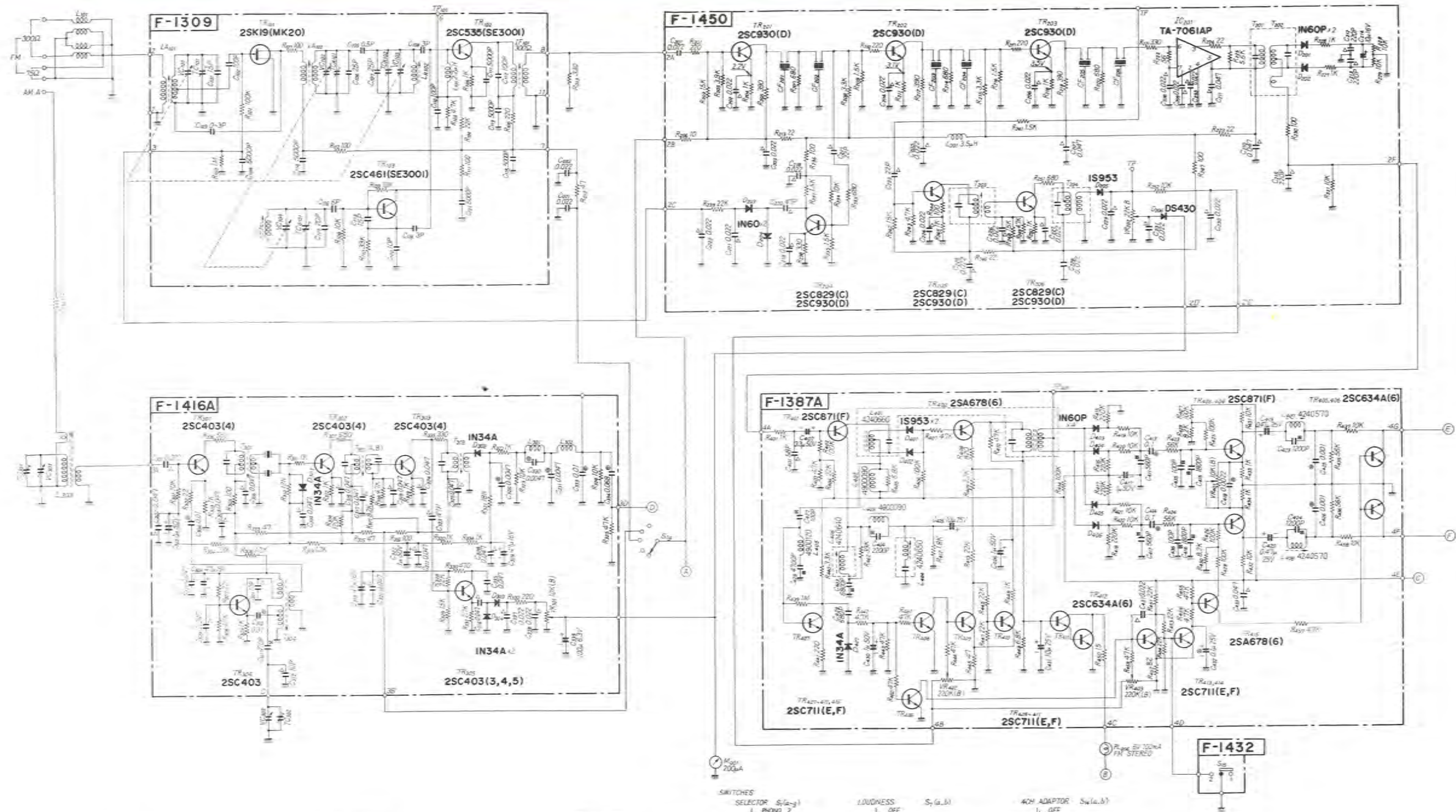

- SWITCHES**
- | | | | | | |
|---------------------------------------|-----------------|--------------|------------|-------|--------|
| SELECTOR $S_1(a, g)$ | 1. PHONO 2 | 2. PHONO 1 | 3. FM AUTO | 4. AM | 5. AUX |
| SPEAKERS A $S_2(a, b)$ | 1. OFF | 2. ON | | | |
| SPEAKERS B $S_3(a, b)$ | 1. OFF | 2. ON | | | |
| SPEAKERS C $S_4(a, b)$ | 1. OFF | 2. ON | | | |
| LOW FILTER $S_5(a, b)$ | 1. OFF | 2. ON | | | |
| HIGH FILTER $S_6(a, b)$ | 1. OFF | 2. ON | | | |
| Loudness $S_7(a, b)$ | 1. OFF | 2. ON | | | |
| REVERSE $S_8(a, b)$ | 1. NORMAL | 2. REVERSE | | | |
| MONO $S_9(a, b)$ | 1. OFF (STEREO) | 2. ON (MONO) | | | |
| NOISE REDUCTION ADAPTOR $S_{10}(a-d)$ | 1. OFF | 2. ON | | | |
| TAPE MONITOR I $S_{11}(a-d)$ | 1. OFF | 2. ON | | | |
| TAPE MONITOR $S_{12}(a-d)$ | 1. OFF | 2. ON | | | |
| SOURCE $S_{13}(a, b)$ | 1. OFF | 2. ON | | | |
| 4OH ADAPTOR $S_{14}(a, b)$ | 1. OFF | 2. ON | | | |
| FM MUTING OFF S_{15} | 1. ON | 2. OFF | | | |
| POWER S_{16} | | | | | |
- CAPACITORS**
- ▲ CERAMIC
 - MYLAR
 - STYROL
 - OIL
 - Tantalum

TEST POINTS

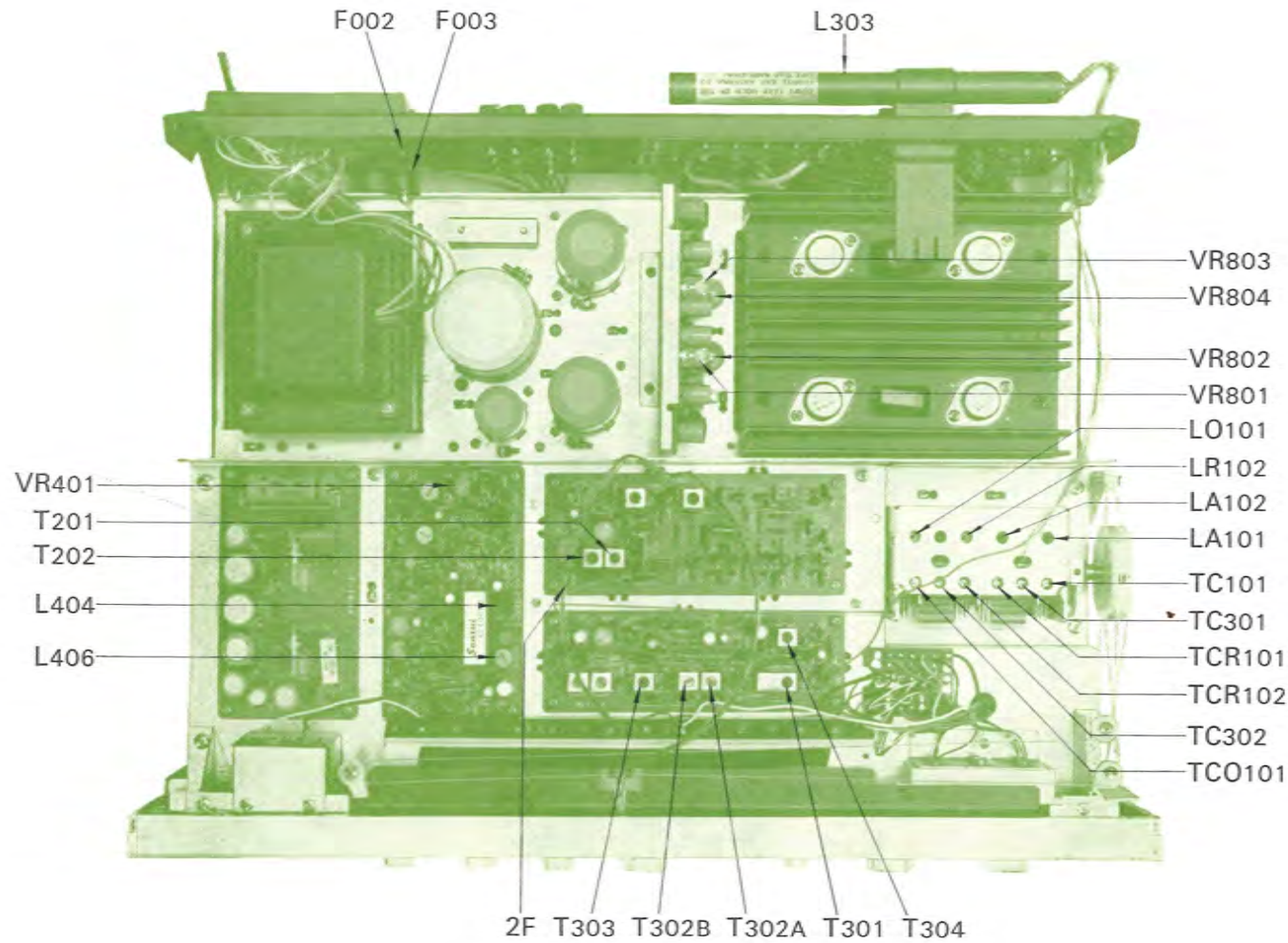

ALIGNMENT

FM ALIGNMENT PROCEDURE

NOTE: Set FM signal generator level to minimum first.

Any internal parts replacement or changes you make in the 3300 require proper alignment again, Test points, alignment procedures and schematic diagrams are given on pages 18~25.

Equipment required: 1. Sweep Generator 2. Oscilloscope 3. FM Signal Generator 4. Multiplex Stereo Generator 5. AC V.T.V.M.

STEP	ALIGN	GENERATOR	FEED SIGNAL	OUTPUT INDICATOR	DIAL SETTING	ADJUST	ADJUST FOR
1.	Discriminator	Sweep generator 10.7MHz ±200kHz	TP ₁₀₁ via 10pF ceramic capacitor	Oscilloscope is connected to 2F		FM discriminator transformer T ₂₀₁ primary and secondary	S curve
2.	O.S.C.	FM signal generator 88MHz, 400Hz 100% modulation	Antenna terminals	Oscilloscope and V.T.V.M. at output load	88MHz	O.S.C. coil LO ₁₀₁	Maximum
3.	O.S.C.	FM signal generator 108MHz, 400Hz 100% modulation	Same as above	Same as above	108MHz	O.S.C. trimmer TCO ₁₀₁	Maximum
4.	Repeat 2 and 3						
5.	RF Amp. Circuit	FM signal generator 90MHz, 400Hz 100% modulation	Same as above	Same as above	90MHz	Antenna coil LA ₁₀₁ , LA ₁₀₂ and LR ₁₀₂	Maximum
6.	RF Amp. Circuit	FM signal generator 106MHz, 400Hz 100% modulation	Same as above	Same as above	106MHz	Trimmer TC ₁₀₁ , TCR ₁₀₁ and TCR ₁₀₂	Maximum
7.	Repeat 5 and 6.						

FM DISCRIMINATOR WAVE FORM

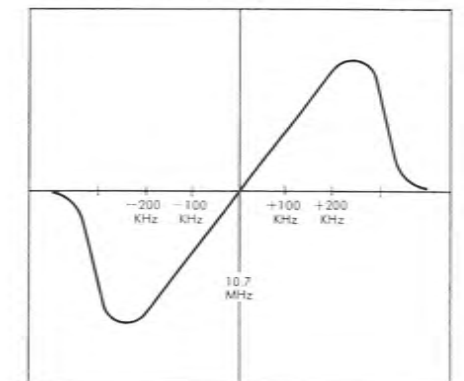

ALIGNMENT

FM MULTIPLEX ALIGNMENT PROCEDURE

Do not attempt to align Multiplex Circuit unless following equipment is available:

a. Multiplex Stereo Generator b. Oscilloscope c. AC V.T.V.M. d. Low Frequency Oscillator e. FM Signal Generator

STEP	ALIGN	GENERATOR	FEED SIGNAL	OUTPUT INDICATOR	ADJUST	ADJUST FOR
1.	Separation VR				VR ₄₀₁	Fully counter-clockwise
2.	67kHz Coil	Low frequency oscillator 67kHz	4A	V.T.V.M. and Oscilloscope at TP ₄₀₁	L ₄₀₄	Minimum
3.	Stereo separation 19kHz Coil	FM signal generator 98MHz 100% modulation Stereo signal generator — composite signal with pilot signal, left channel, 40% modulation	Antenna terminals Tune to signal	V.T.V.M. and oscilloscope at right channel output load	L ₄₀₆	Channel-R minimum
4.	Stereo separation Separation VR	Same as above	Same as above	Same as above	VR ₄₀₁	Same as above

AM ALIGNMENT PROCEDURE

NOTE: To align, set AM signal generator level to minimum.

STEP	ALIGN	GENERATOR	FEED SIGNAL	OUTPUT INDICATOR	DIAL SETTING	ADJUST	ADJUST FOR
1.	IF transformer	Sweep generator 455kHz ±30kHz	Antenna terminals	Oscilloscope and V.T.V.M. at TP ₃₀₁		I.F.T. T ₃₀₁ ~T ₃₀₃	Best IF wave form
2.	O.S.C.	AM generator 535kHz 400Hz 30% modulation	Same as above	Oscilloscope and V.T.V.M. at output load	535kHz	O.S.C. coil T ₃₀₄	Maximum
3.	O.S.C.	AM generator 1600kHz 400Hz 30% modulation	Same as above	Same as above	1600kHz	O.S.C. trimmer cap. TC ₃₀₂	Maximum
4.	Repeat 2 and 3						
5.	Antenna circuit	AM generator 600kHz 400Hz 30% modulation	Same as above	Same as above	600kHz	Ferrite bar antenna coil L ₃₀₃	Maximum
6.	Antenna circuit	AM generator 1400kHz 400Hz 30% modulation	Same as above	Same as above	1400kHz	Antenna circuit trimmer TC ₃₀₁	Maximum
7.	Repeat 5, 6						

AM IF WAVE FORM

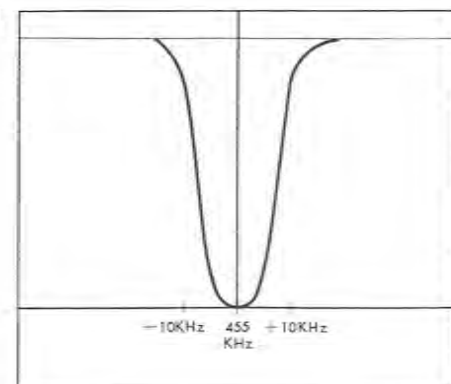

CURRENT ADJUSTMENT

STEP	SET AMMETER (TESTER) TO	WHAT TO DO	NOTE
1.		Remove F ₀₀₂ (left channel) and F ₀₀₃ (right channel)	Use ammeter with 100mA range
2.		Set VR ₃₀₂ (left and right channel) to minimum	
3.		Set Volume Control to minimum	
4.		Turn on receiver	Be sure to switch on receiver before connecting ammeter
5.	100mA range.	Connect ammeter to F ₀₀₂ as illustrated in Fig. 1	
6.		Turn VR ₃₀₂ (left channel) clockwise and adjust current to 17 to 13 mA	
7.	100mA range.	Turn off receiver and replace F ₀₀₂	
8.		Turn on receiver and connect ammeter to F ₀₀₃ as illustrated in Fig. 1	
9.		Turn VR ₃₀₂ (right channel) clockwise and adjust current to 17 to 13 mA	
10.		Replace F ₀₀₃	

OUTPUT ADJUSTMENT

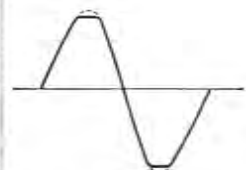
STEP	WHAT TO DO	NOTE
1.	Adjust volume control to minimum	
2.	Set oscillator to 1,000Hz and connect it to AUX input	Oscillator used should have oscillating frequency of 20 to 20,000Hz and output voltage of more than 200mV
3.	Set Selector Control to AUX	Push SPEAKERS-A Switch, then set other controls and switches as follows: Balance to CENTER Tape Monitor to OFF Tone to CENTER Others to OFF
4.	Connect 8- or 16-ohm resistor with capacity of more than 45 watts to SYSTEM-A LEFT speaker terminal	
5.	Connect oscilloscope to SPEAKER terminal	
6.	Turn on receiver and slowly raise volume. Check output at terminal by means of oscilloscope	
7.	Adjust VR ₃₀₁ (left channel) so that peak of sine wave is clipped simultaneously	
8.	Adjust right channel similarly	

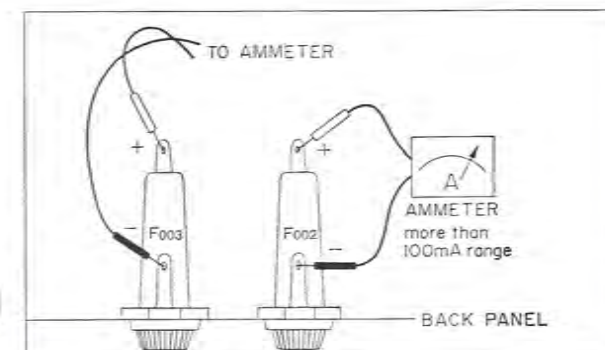

(Fig. 1) QUICK-ACTING FUSE HOLDER

PRINTED CIRCUIT BOARDS AND PARTS LIST

W: Parts No. X: Parts Name Y: Stock No. Z: Position of Parts

AM BLOCK <F-1416A>

Stock No. 7530210

W	X	Y	Z
R301	10kΩ	0101102	1 A
R302	22Ω	0101220	1 A
R303	1kΩ	0101102	1 A, B
R304	2.7kΩ	0101272	2 A
R305	100Ω	0101101	2 A, B
R306	1.2kΩ	0101122	2 B
R307	22kΩ	0101223	2 A, B
R308	4.7kΩ	0101472	1, 2 A
R309	1kΩ	0101102	2 A
R310	12kΩ	0101123	1 B
R311	1kΩ	0101102	1 B
R312	1kΩ	0101102	1 B
R313	1.2kΩ	0101122	2 B
R314	120kΩ	0101124	2 B
R315	47Ω	0101470	2 B
R316	100Ω	0101101	2 C
R317	8.2kΩ	0101822	1 C
R318	4.7kΩ	0101472	1 B, C
R319	1kΩ	0101102	1 C
R320	1kΩ	0101102	1 B, C
R321	18kΩ	0101183	2 C
R322	1kΩ	0101102	2 C, D
R323	10kΩ	0101103	1 D
R324	10kΩ	0101103	1 D
R325	47kΩ	0101473	1, 2 D
R326	560Ω	0101561	1 A
R327	680Ω	0101681	1 B
R328	22kΩ	0101223	2 B, C
R329	15kΩ	0101153	2 B, C
R330	470Ω	0101471	2 B, C
R331	2.7kΩ	0101272	2 C
R332	220Ω	0101221	2 D
R333	47Ω	0101470	2 B
R334	1kΩ	0101102	2 C
R335	330Ω	0100331	1 C
VR301	10kΩ(B) Signal Meter Adj.(AM)	1035130	2 D
C301	0.022μF $\begin{matrix} +80\% \\ -20\% \end{matrix}$ 50V CC.	0657223	1 A
C302	0.047μF $\begin{matrix} +80\% \\ -20\% \end{matrix}$ 25V CC.	0656473	1 A
C303	1μF 50V EC.	0515109	2 A
C304	0.01μF $\pm 10\%$ 50V MC.	0601107	1, 2 A
C305	0.047μF 25V CC.	0656473	1 B
C306	0.047μF $\begin{matrix} +80\% \\ -20\% \end{matrix}$ 25V CC.	0656473	1 A
C307	0.047μF 25V CC.	0656473	2 B
C308	47μF 16V EC.	0612470	2 B
C309	0.047μF $\begin{matrix} +80\% \\ -20\% \end{matrix}$ 25V CC.	0656473	2 A
C310	0.01μF $\pm 10\%$ 50V MC.	0601107	2 A
C311	470pF $\pm 5\%$ 50V SC.	0621471	2 B
C312	10pF $\pm 10\%$ 50V CC.	0660100	2 B
C313	10pF 50V CC.	0660100	2 A
C314	0.047μF 25V CC.	0656473	2 B
C315	0.047μF $\begin{matrix} +80\% \\ -20\% \end{matrix}$ 25V CC.	0656473	1 B
C317	0.047μF $\begin{matrix} +80\% \\ -20\% \end{matrix}$ 25V CC.	0656473	1 B
C318	0.047μF 25V CC.	0656473	1 C
C319	47μF 16V EC.	0512470	1 B

W	X	Y	Z
C320	0.047μF $\begin{matrix} +80\% \\ -20\% \end{matrix}$ 25V CC.	0656473	2 B, C
C321	0.047μF $\begin{matrix} +80\% \\ -20\% \end{matrix}$ 25V CC.	0656473	2 B
C322	1μF 50V EC.	0515109	2 B
C323	47pF $\pm 10\%$ 50V CC.	0660470	1, 2 C
C324	0.047μF $\begin{matrix} +80\% \\ -20\% \end{matrix}$ 25V CC.	0656473	1 C
C325	0.047μF $\begin{matrix} +80\% \\ -20\% \end{matrix}$ 25V CC.	0656473	1 C
C326	0.0047μF $\pm 10\%$ 50V MC.	0601476	1 C
C328	0.047μF $\begin{matrix} +80\% \\ -20\% \end{matrix}$ 50V CC.	0656473	2 C
C329	4.7μF 16V EC.	0512479	2 C
C330	0.0047μF 50V MC.	0601476	1, 2 D
C331	0.0047μF $\pm 10\%$ 50V MC.	0601476	1 D
C333	0.01μF $\pm 10\%$ 50V MC.	0601107	2 D
C334	0.068μF 50V MC.	0601687	2 D
C335	0.047μF 16V CC.	0656473	2 C
C336	0.047μF 16V CC.	0656473	2 C
C337	0.022μF $\begin{matrix} +80\% \\ -20\% \end{matrix}$ 50V CC.	0657223	2 C
C338	0.022μF $\begin{matrix} +80\% \\ -20\% \end{matrix}$ 50V CC.	0657223	2 D
C339	100μF 6.3V EC.	0510101	2 D
TR301		0305992	1 A
TR302	2SC403 (4)	0305992	1 B
TR303		0305992	1 C
TR304		0305991.2.3	2 A
TR305	2SC403 (3, 4, 5)	0305991.2.3	2 C
D301		0310400	1 B
D302		0310400	1 C
D303	1N34A	0310400	2 C
D304		0310400	2 C
T301	YFL-455E (Ceramic Filter)	0910180	1 A, B
T302A		4230590	1 B
T302B	AM IF Coil	4230600	1 C
T303		4230580	1 C
T304	AM OSC Coil	4220390	2 A
L301	Filter's Coil	4290200	1 D
L302		4290200	1 D
	Printed Circuit Board F-1416	2530140	

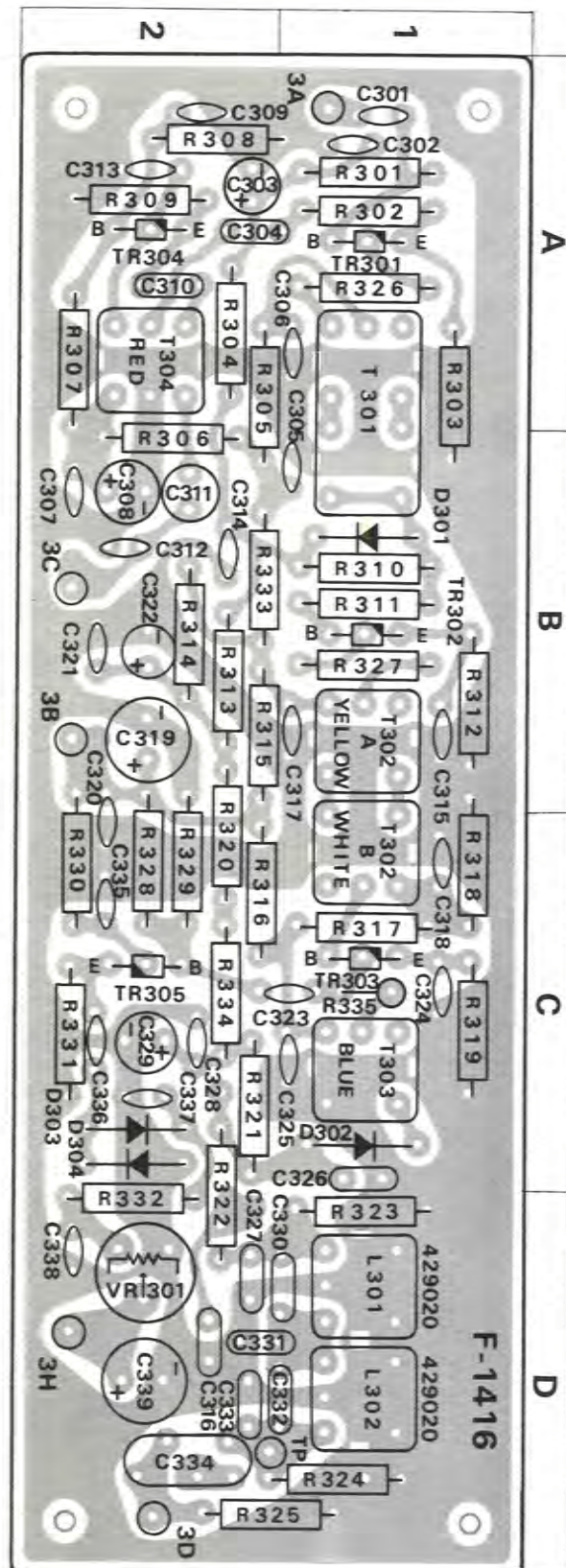

Abbreviations

- CR : Carbon Resistor
- SR : Solid Resistor
- CeR : Cement Resistor
- MFR: Metal Oxide Film Resistor
- CC : Ceramic Capacitor
- EC : Electrolytic Capacitor
- MC : Mylar Capacitor
- SC : Styrol Capacitor
- AEC: Aluminium Solid Electrolytic Capacitor
- TC : Tantalum Capacitor

PRINTED CIRCUIT BOARDS AND PARTS LIST

W: Parts No. X: Parts Name Y: Stock No. Z: Position of Parts

FM IF BLOCK (F-1450)

Stock No. 7520510

W	X	Y	Z
R201	220Ω	0100221	2D
R202	15kΩ	0100153	2D
R203	3.9kΩ	0100392	2D
R204	1kΩ	0100102	2D
R205	390Ω	0101391	2D
R206	10Ω	0100100	1D
R207	680Ω	0101681	2D
R208	3.3kΩ	0101332	2D
R209	1.5kΩ	0100152	2D
R210	220Ω	0100221	2D
R211	1kΩ	0100102	2C
R212	390Ω	0101391	2C
R213	22Ω	0101220	1C, D
R214	680Ω	0101681	2C
R215	3.3kΩ	0101332	2C
R216	1.5kΩ	0100152	2C
R217	220Ω	0101221	2C
R218	1kΩ	0100102	2C
R219	390Ω	0101391	2C
R220	680Ω	0101681	2B
R221	330Ω	0101331	2B
R222	56Ω	0100560	2B
R223	22Ω	0101220	2B
R224	22Ω	0100220	2B
R225	5.6kΩ	0100562	2B
R226	1kΩ	0100102	1A
R227	1kΩ	0100102	1A
R228	10kΩ	0100103	1A
R229	10kΩ	0100103	1A
R230	100Ω	0101101	2A
R231	10kΩ	0101103	2B
R233	680Ω	0101681	1, 2D
R234	10kΩ	0101103	1D
R235	1.5kΩ	0101152	1C, D
R236	100Ω	0101101	1C
R237	1.5kΩ	0101152	1D
R238	330Ω	0100331	1D
R239	22kΩ	0100223	1C
R241	1.5kΩ	0101152	1, 2B
R242	15kΩ	0100153	1C
R243	4.7kΩ	0100472	1C
R244	100Ω	0100101	1C
R245	1kΩ	0100102	1C
R246	22Ω	0101220	1B, C
R247	100Ω	0101101	1, 2B
R248	15kΩ	0100153	1B
R249	4.7kΩ	0100472	1B
R250	1kΩ	0100102	1B
R251	680Ω	0100681	1B
R252	10kΩ	0100103	1A, B
VR202	22kΩ(B) Signal Meter Adj. (FM)	1035150	1, 2A
C201	0.022μF	0657223	1, 2D
C202	0.022μF	0657223	2D
C203	0.022μF	0657223	1D

W	X	Y	Z
C204	0.022μF	0657223	2D
C205	0.022μF	0657223	2C
C206	0.022μF	0657223	2C
C207	0.047μF	0657473	1, 2C
C208	0.022μF	0657223	2B
C209	0.022μF	0657223	1B
C210	0.047μF	0657473	2B
C211	0.047μF	0657473	2A
C212	220 pF	0660221	1A
C213	220 pF	0660221	1A
C214	10μF	0512100	1A
C215	220 pF	0660221	2A
C217	22 pF	0660220	2D
C218	0.022μF	0657223	1D
C219	0.022μF	0657223	1D
C220	47 pF	0660470	1D
C221	0.022μF	0657223	1C
C222	0.022μF	0657223	1C
C223	22 pF	0660220	1C
C224	0.022μF	0657223	1C
C225	0.022μF	0657223	1C
C226	0.022μF	0657223	1B
C227	0.022μF	0657223	1B
C228	0.022μF	0657223	1B
C229	0.022μF	0657223	1B
C230	0.022μF	0657223	1A
C231	0.022μF	0657223	1A
C233	0.022μF	0657223	2B
TR201		0305791	2D
TR202		0305791	2C
TR203		0305791	2C
TR204		0305791	1D
TR205		0305791	1C
TR206		0305791	1B
D201	1N60P	0311060	2A
D202	1N60P	0311060	2A
D203	1N60	0310331	1D
D204	1N60	0310331	1D
D205	1S953	0311050	1B
D206	DS-430	0340090	1A
IC201	TA-7061AP	0360060	2B
CF201		0910100	2D
CF202		0910100	2D
CF203		0910100	2C
CF204		0910100	2C
CF205		0910100	2C
CF206		0910100	2C
CF207		0910100	2B
T201	Discriminating Transformer	4235750	2A, B
T202	Discriminating Transformer	4235760	2A
T203	Signal Meter Coil	4235770	1B, C
T204	Signal Meter Coil	4235780	1B
L201	Micro Inductor	4290011	1C
	Printed Circuit Board F-1450	2520320	

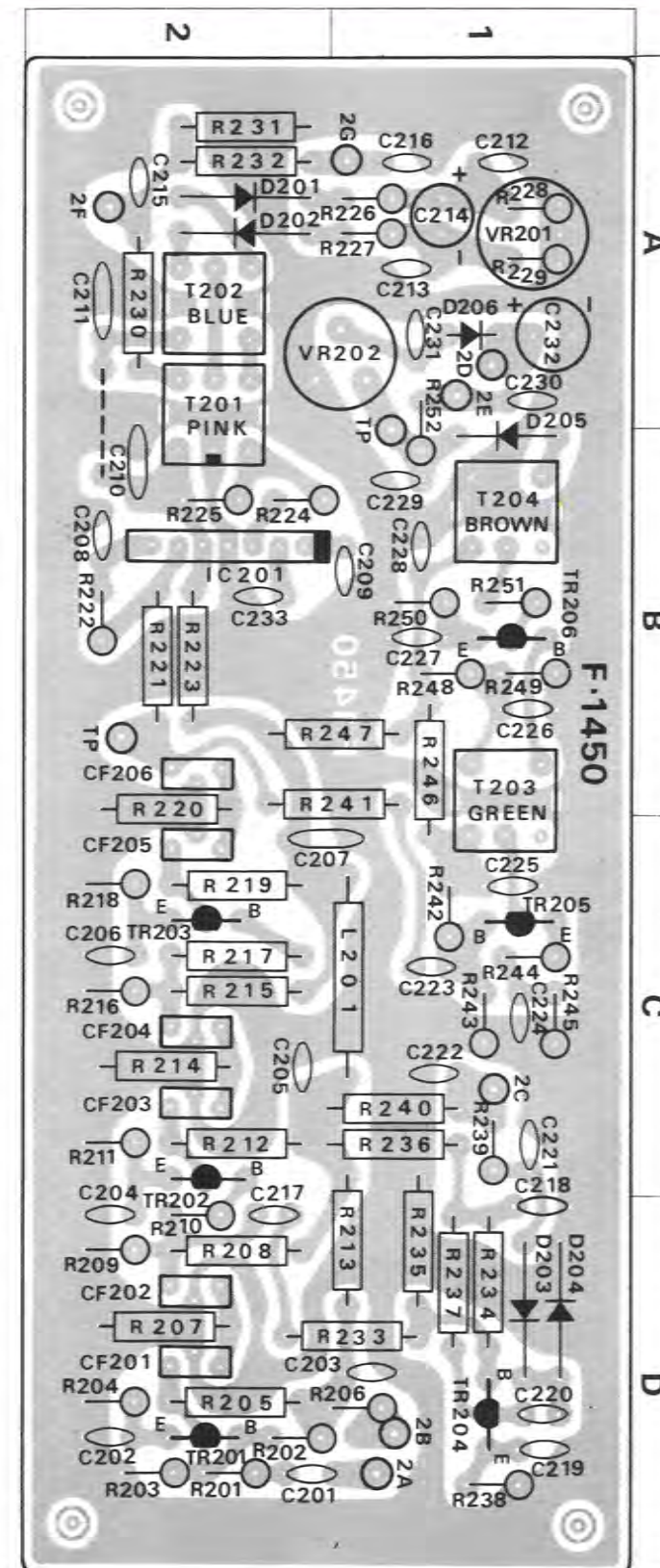

PRINTED CIRCUIT BOARDS AND PARTS LIST

W: Parts No. X: Parts Name Y: Stock No. Z: Position of Parts

FM MPX BLOCK <F-1387A>

Stock No. 7540650

W	X	Y	Z
R401	1kΩ	0100102	1 C
R402	100kΩ	0100104	1 C
R403	4.7kΩ	0100472	1 C
R404	22kΩ	0100223	1 C
R405	6.8kΩ	0100682	1 C
R406	100kΩ	0100104	1 B
R407	4.7kΩ	0100472	2 B
R408	820Ω	0100821	2 B
R409	2.2kΩ	0100222	2 B
R410	47kΩ	0100473	1 B
R412	1.8kΩ	0100182	1 B
R413	22kΩ	0100223	2 B
R414	100kΩ	0100104	2 B
R415	220kΩ	0100224	1 A, B
R416	220kΩ	0100224	1 A, B
R417	220kΩ	0100224	1 A, B
R418	220kΩ	0100224	1 A
R419	10kΩ	0100103	1 A
R420	10kΩ	0100103	1 A
R421	10kΩ	0100103	1 A
R422	10kΩ	0100103	1 A
R423	56kΩ	0100563	1 A
R424	56kΩ	0100563	1 A
R425	100kΩ	0100104	1 A
R426	100kΩ	0100104	1 A
R427	100kΩ	0100104	1 A
R428	100kΩ	0100104	1 A
R429	8.2kΩ	0100822	1 A
R430	8.2kΩ	0100822	1 A
R431	10kΩ	0100103	1 A
R432	10kΩ	0100103	2 A
R433	1kΩ	0100102	2 A
R434	1kΩ	0100102	1 A
R435	56kΩ	0100563	2 A
R436	56kΩ	0100563	2 A
R437	10kΩ	0100103	2 A
R438	10kΩ	0100103	2 A
R439	1MΩ	0100105	2 C
R440	3.3kΩ	0100332	1, 2 C
R441	220Ω	0100221	2 C
R442	4.7kΩ	0100472	2 C
R443	47kΩ	0100473	2 C
R444	47kΩ	0100473	2 B
R445	47Ω	0100470	2 C
R446	22kΩ	0100223	2 C
R447	22kΩ	0100223	2 C
R448	1kΩ	0100102	2 B, C
R449	6.8kΩ	0100682	1, 2 B
R450	15Ω	0100150	2 B
R451	22kΩ	0100223	2 B
R452	82Ω	0100820	2 B
R453	22kΩ	0100223	2 B
R454	22kΩ	0100223	2 B
R455	47kΩ	0100473	2 B
R456	4.7kΩ	0100472	2 B
R457	4.7kΩ	0101472	2 A

W	X	Y	Z
R459	47kΩ	0100473	2 B
R460	47kΩ	0100473	2 C
R461	47kΩ	0100473	2 C
R462	39kΩ	0100393	1 C
VR401	10kΩ(B) Stereo Separation Adj.	1035130	1 A
VR402	220kΩ(B) FM Stereo Indicator Adj.	1035210	2 C
VR403	220kΩ(B) Muting Adj.	1035210	2 B
C401	68 pF ±10% 50V CC.	0660680	1 C
C402	3.3 μF 50V EC.	0515339	1 C
C403	6800 pF ±5% 50V SC.	0629001	1 C
C404	2200 pF ±5% 50V SC.	0620222	1 B
C405	10 μF 25V EC.	0513100	1 B
C406	1 μF 50V EC.	0515109	2 B
C411	560 pF ±10% 50V SC.	0620561	1 A
C412	560 pF ±10% 50V SC.	0620561	1 A
C413	0.1 μF ±10% 50V MC.	0601108	1 A
C414	0.1 μF ±10% 50V MC.	0601108	1 A
C415	1800 pF ±5% 50V SC.	0620182	1 A
C416	1800 pF ±5% 50V SC.	0620182	1 A
C417	1 μF 50V EC.	0515109	1, 2 B
C418	0.0022 μF ±10% 50V MC.	0601226	2 A
C419	0.47 μF 25V AEC.	0563478	2 A
C420	0.47 μF 25V AEC.	0563478	1, 2 A
C423	1200 pF ±5% 50V SC.	0620122	2 A
C424	1200 pF ±5% 50V SC.	0620122	2 A
C425	0.001 μF ±10% 50V MC.	0601106	2 A, B
C426	0.001 μF ±10% 50V MC.	0601106	2 A
C427	100 pF ±5% 50V SC.	0620101	1 C
C428	4700 pF ±5% 50V SC.	0620472	2 C
C429	680 pF ±5% 50V SC.	0620681	2 C
C430	1 μF 50V EC.	0515109	2 C
C431	10 μF 25V EC.	0513100	2 B
C432	0.1 μF 25V TC.	0573108	2 B
C433	0.047 μF ±80% -20% 50V CC.	0657473	2 B
C435	100 pF ±5% 50V SC.	0620101	2 B
C436	100 pF ±5% 50V SC.	0620101	2 B
C437	0.022 μF ±80% -20% 50V CC.	0657223	2 B
TR401	2SC871(F)	0305472	1 C
TR402	2SA678(6)	0300291	1, 2 B
TR403	2SC871(F)	0305472	1 A
TR404	2SC871(F)	0305472	1 A
TR405	2SC634A(6)	0305891	2 A
TR406	2SC634A(6)	0305891	2 A
TR407		0305731, 2	2 C
TR408		0305731, 2	2 C
TR409	2SC711(E, F)	0305731, 2	2 C
TR410	2SC711(E, F)	0305731, 2	2 C
TR411	2SC711(E, F)	0305731, 2	2 B
TR412	2SC634A(6)	0305891	2 B
TR413	2SC711(E, F)	0305731, 2	2 B
TR414	2SC711(E, F)	0305731, 2	2 B
TR415	2SA678(6)	0300291	2 B
TR416	2SC711(E, F)	0305731, 2	2 C
D401	1S953	0311050	1 C
D402		0311060	2 B, C

W	X	Y	Z
D403	1N60P	0311060	1 B
D404		0311060	1 B
D405		0311060	1 B
D406		0311060	1 B
D407	1N34A	0310400	2 C
L401	FM MPX Coil	4240660	1 B, C
L402	Micro Inductor	4900090	1 C
L403		4900090	1 B
L404	FM MPX Coil	4240650	1 B
L405	Micro Inductor	4900120	2 C
L406	FM MPX Coil	4240640	1 C
L407		4240570	2 A
L408		4240570	2 A
	Printed Circuit Board F-1387-2	2540260	

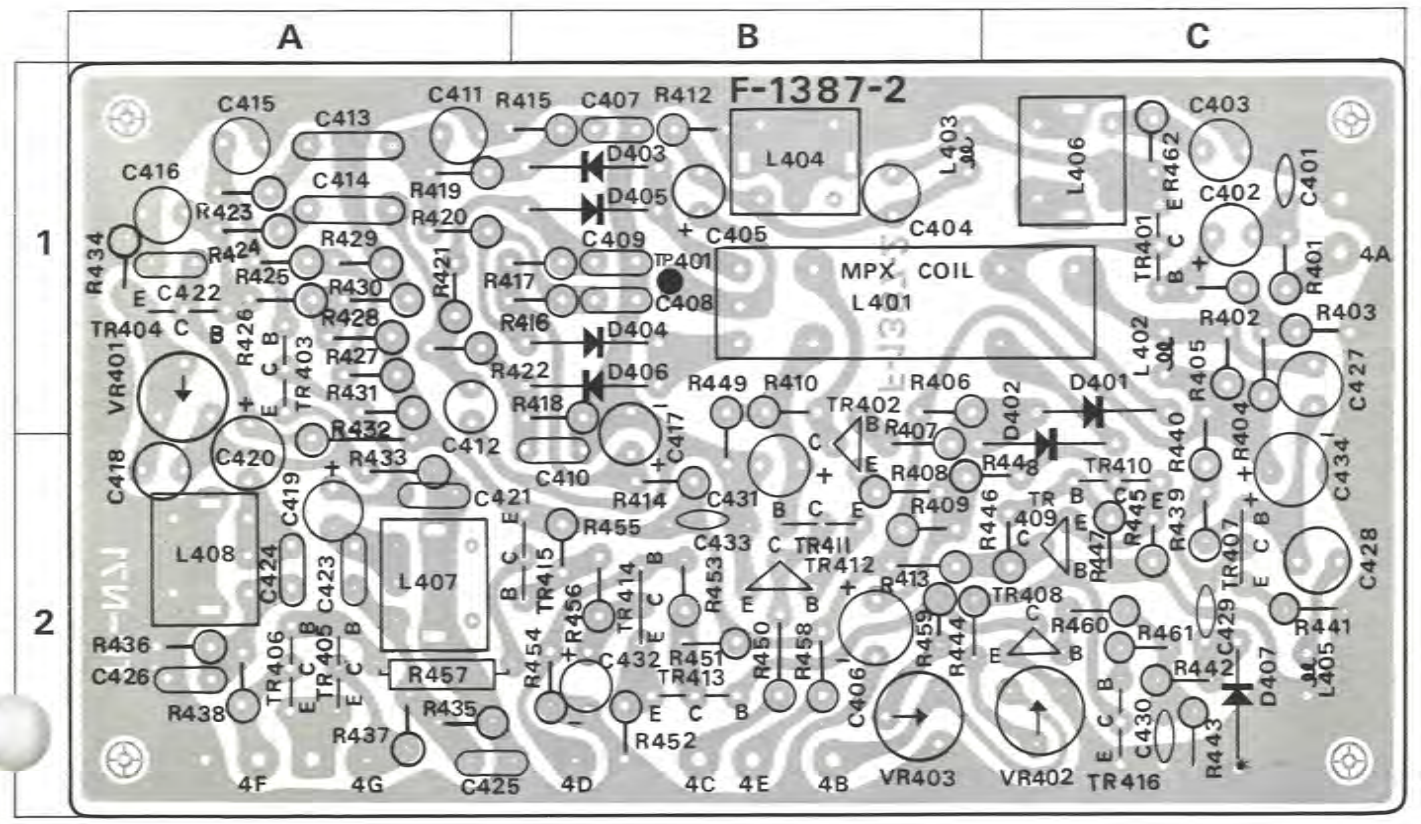

PRINTED CIRCUIT BOARDS AND PARTS LIST

W: Parts No. X: Parts Name Y: Stock No. Z: Position of Parts

EQUALIZER BLOCK <F-1267C>

Stock No. 7550380

W	X	Y	Z
R601	1kΩ	0101102	2 B
R602	1kΩ	0101102	2 A
R603	56kΩ	0101563	2 B
R604	56kΩ	0101563	2 A
R605	390kΩ	0101394	2 B
R606	390kΩ	0101394	2 A
R607	3.9kΩ	0101392	2 B
R608	3.9kΩ	0101392	2 A
R609	470Ω	0101471	1 B
R610	470Ω	0101471	1 A
R611	180kΩ	0101184	1 B
R612	180kΩ	0101184	1 A
R613	680Ω	0101681	1 B
R614	680Ω	0101681	1 A
R615	8.2kΩ	0101822	1 B
R616	8.2kΩ	0101822	1 A
R617	82kΩ	0101823	2 B
R618	82kΩ	0101823	2 A
R619	330kΩ	0101334	1 B
R620	330kΩ	0101334	1 A
R621	470Ω	0101471	1 B
R622	470Ω	0101471	1 A
R623	22kΩ	0101223	1 B
R624	22kΩ	0101223	1 A

±10% 1/4W CR.

W	X	Y	Z
C601	1.5μF	25V TC.	0573159 2 B
C602	1.5μF	25V TC.	0573159 2 B
C603	68pF		0660680 2 B
C604	68pF	±10% 50V CC.	0660680 2 A
C605	68pF	±10% 50V CC.	0660680 1 B
C606	68pF		0660680 1 A
C607	3.3μF		0515339 2 B
C608	3.3μF	50V EC.	0515339 2 A
C609	33μF		0510101 2 B
C610	33μF	10V EC.	0510101 2 A
C611	0.47μF		0573478 1 B
C612	0.47μF	25V TC.	0573478 1 A
C613	0.012μF		0601127 1 B
C614	0.012μF		0601127 1 A
C615	0.0033μF	±10% 50V MC.	0601336 1 B
C616	0.0033μF		0601336 1 A
TR601		2SC871R(E)	0305474 2 B
TR602		2SC871R(E)	0305474 2 A
TR603		2SC871R(F)	0305475 2 B
TR604		2SC871R(F)	0305475 2 A
	Printed Circuit Board F-1267		2550140

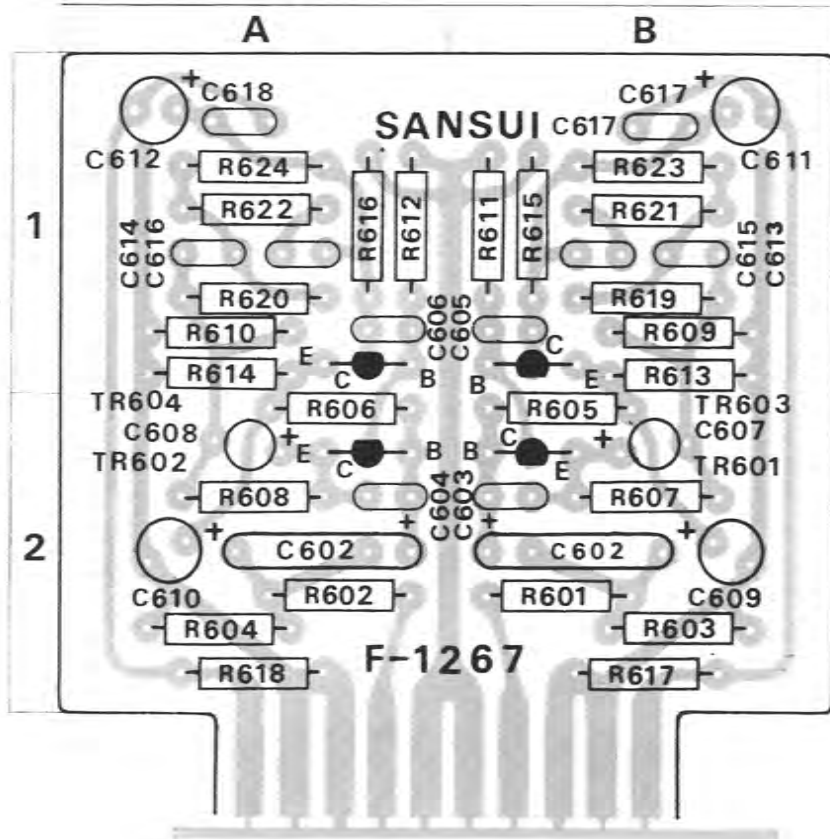

TONE & FILTER BLOCK <F-1431>

Stock No. 7560520

W	X	Y	Z
R701	2.2kΩ	0101222	1 B
R702	1MΩ	0101105	1 B
R703	220kΩ	0101224	1 B
R704	220kΩ	0101224	1 B
R705	120kΩ	0101124	1 B
R706	12kΩ	0101123	1 A
R707	22kΩ	0101223	1 A
R708	1.8kΩ	0101182	1 A
R709	1kΩ	0101102	1 B
R710	330Ω	0101331	1 B
R711	5.6kΩ	0101562	1 A, B
R712	1kΩ	0101102	1 B
R713	47kΩ	0101473	1 A
R714	3.3kΩ	0101332	1 A
R715	820kΩ	0101824	1 A
R716	100kΩ	0101104	1 A
R717	220kΩ	0101224	1 A
R718	220kΩ	0101224	1 A
C701	0.22μF	25V TC.	0573228 1 B
C702	10μF	25V EC.	0513100 1 B
C703	0.022μF		0601227 1 B
C704	0.15μF	±10% 50V MC.	0601158 1 A, B
C705	0.0047μF	±10% 50V MC.	0601476 1 B
C706	0.033μF		0601337 1 B
C707	10μF	25V EC.	0513100 1 B
C708	10pF	±10% 50V CC.	0660100 1 B
C709	47μF	6.3V EC.	0510470 1 B
C710	4.7μF	25V EC.	0513479 1 A
C711	0.015μF	±10% 50V MC.	0601157 1 A
C712	0.022μF	±10% 50V MC.	0601227 1 A
TR701	2SA640(L, M)	0300301, 2	1 B
TR702	2SC632A(71)	0305761	1 B
	Printed Circuit Board F-1431		2560500

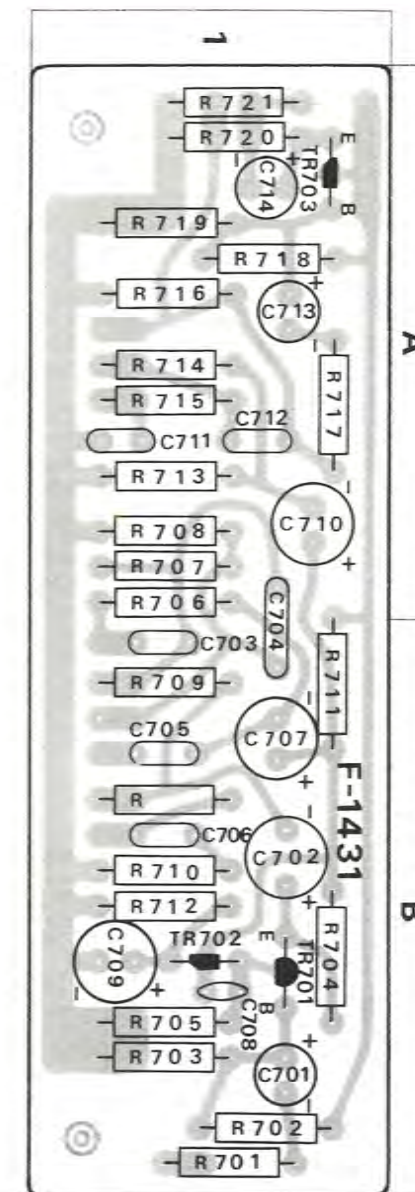

PRINTED CIRCUIT BOARDS AND PARTS LIST

W: Parts No. X: Parts Name Y: Stock No. Z: Position of Parts

DRIVER BLOCK <F-1180F> (Cont'd)

Stock No. 7570630

W	X	Y	Z
C813	220 μ F 10V EC.	0511221	1 C
C814	10 μ F 16V EC.	0512100	1 C
C815	33 μ F 50V EC.	0515330	1 B
C816	100 μ F 6.3V EC.	0510101	2 C
C817	10 μ F 50V EC.	0515100	1 B
C818	0.047 μ F $\pm 10\%$ 50V MC.	0601477	2 C
C820	47 pF	0660470	1 B
C823	47 pF	0660470	2 A
C824	47 pF	0660470	2 C
C825	330 pF $\pm 10\%$ 50V CC.	0660331	2 B
C826	330 pF	0660331	2 B
C827	100 pF	0660101	
C828	100 pF	0660101	
TR801	2SC458L(G) K5C1845	0305311	1 A
TR802	2SC1124(2, 3)	0305901, 2	1, 2 A
TR803	2SC281(B)	0305121	2 B
TR804	2SC959(K, L)	0305740, 1	2 B
TR805	2SA606(K, L)	0300210, 1	2 A
TR806	2SC458L(G) K5C1845	0305311	1 C
TR807	2SC1124(2, 3)	0305901, 2	1, 2 C
TR808	2SC281(B)	0305121	2 B
TR809	2SC959(K, L)	0305740, 1	2 A
TR810	2SA606(K, L)	0300210, 1	2 C
Printed Circuit Board F-1180			2570221

POWER BLOCK <F-1434>

Stock No. 7500650

W	X	Y	Z
R001	12k Ω $\pm 10\%$ 1/4W CR.	0101123	1 A
R002	22 Ω $\pm 10\%$ 1W CR.	0104220	1 A
R003	3.3k Ω	0101332	1 A
R004	68 Ω	0101680	1 A
R005	100 Ω $\pm 10\%$ 1/4W CR.	0101101	1 A
R006	2.2k Ω	0101222	1 B
R007	330 Ω	0101331	1 B
R009	330 Ω $\pm 10\%$ 3W CeR	0153331	1 B
R010	4.7k Ω $\pm 10\%$ 1/4W CR.	0101472	1 B
C001	100 μ F 100V EC.	0507101	1 A
C002	0.1 μ F $\pm 80\%$ 500V CC.	0659011	1 A
C003	0.047 μ F $\pm 80\%$ 50V CC.	0657473	1 A
C004	0.047 μ F $\pm 20\%$ 50V CC.	0657473	1 A
C005	220 μ F	0514221	1 B
C006	220 μ F 35V EC.	0514221	1 B
C007	0.047 μ F $\pm 80\%$ 50V CC.	0657473	1 A, B
C008	220 μ F 25V EC.	0513221	1 B
C009	0.047 μ F $\pm 80\%$ 50V CC.	0657473	1 B
C010	220 μ F 35V EC.	0514221	1 A
C011	100 μ F 25V EC.	0513101	1 B
C012	330 μ F 16V EC.	0512331	1 B
C013	0.047 μ F $\pm 80\%$ 50V CC.	0657473	1 B
C014	470 μ F 10V EC.	0511471	1 A
TR001	2SC1124(2, 3)	0305901, 2	1 A
TR002	2SD330(D, E)	0308361, 2	1 A
TR003		0308361, 2	1 B
D001,002	10DC-1	0310680	1 A
D003	10D-05	0310880	1 A
ZD001	RD35A-L	0315480	1 B
ZD002	RD13A-M	0315300	1 B
Printed Circuit Board F-1434			2500530

SWITCH (A) BLOCK <F-1432>

Stock No. 7590900

W	X	Y	Z		
R751	10k Ω	0101103			
R752	10k Ω $\pm 10\%$ 1/4W CR.				
S8	'REVERSE'	1130550	Pushbutton Switch		
S9	'MONO'				
S10	'N.R ADAPTOR'				
S11	'TAPE-1'				
S12	'TAPE-2'				
S13	'SOURCE'				
S14	'4CH ADAPTOR'				
S15	'FM MUTING OFF'				
Printed Circuit Board F-1432				2591110	

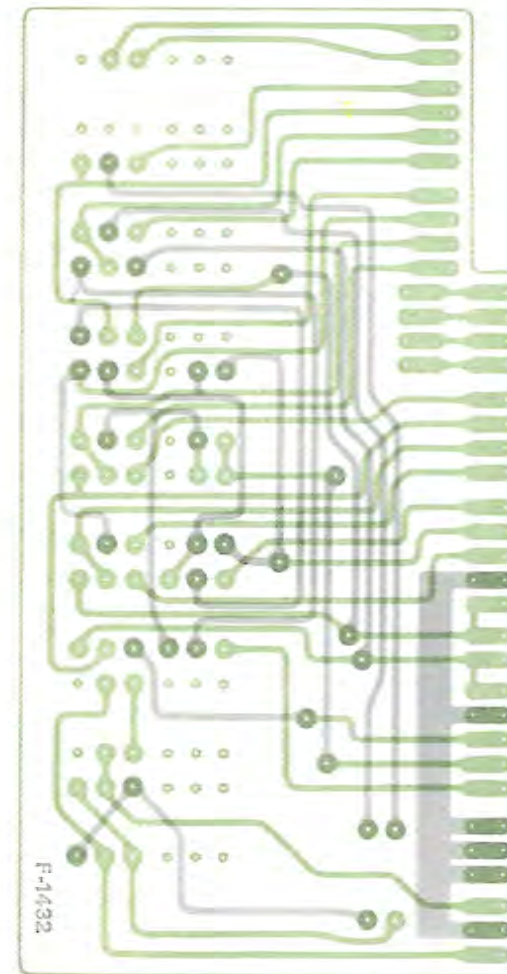

LAMP BLOCK <F-1374A>

Stock No. 7590890

W	X	Y	Z
PL008	7V 300mA Dial Indicator Lamp	0420040	
PL009		0420040	
PL010		0420040	
PL011		0420040	
PL012		0420040	
Holder			2310050
Printed Circuit Board F-1374			2590760

SWITCH (B) BLOCK <F-1433>

Stock No. 7590910

W	X	Y	Z
R753	10k Ω	0101103	
R754	10k Ω $\pm 10\%$ 1/4W CR.		
R755	22k Ω		
R756	22k Ω		
C751	470 pF $\pm 5\%$ 50V SC.	0620471	
C752	470 pF $\pm 5\%$ 50V SC.	0620471	
C753	0.022 μ F $\pm 10\%$ 50V CC.	0601227	
C754	0.022 μ F $\pm 10\%$ 50V CC.	0601227	
S2	'SPEAKERS A'	1130580	Pushbutton Switch
S3	'SPEAKERS B'		
S4	'SPEAKERS C'		
S5	'LOW FILTER'		
S6	'HIGHT FILTER'		
S7	'LOUDNESS'		
Printed Circuit Board F-1433			

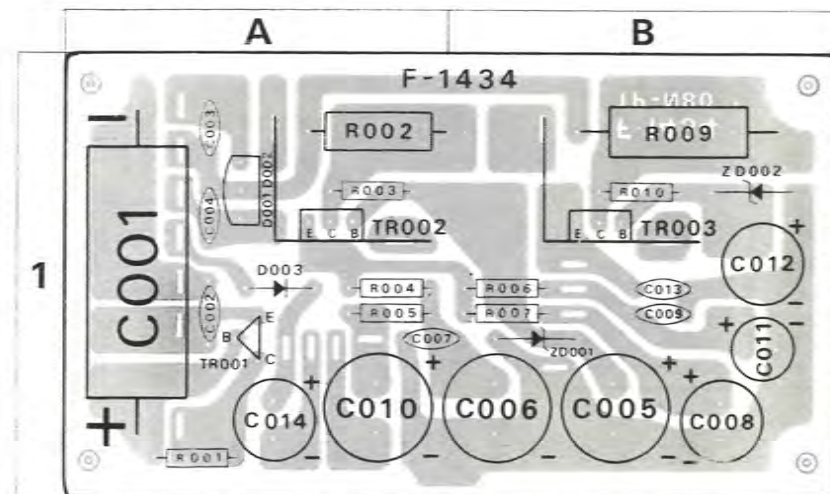
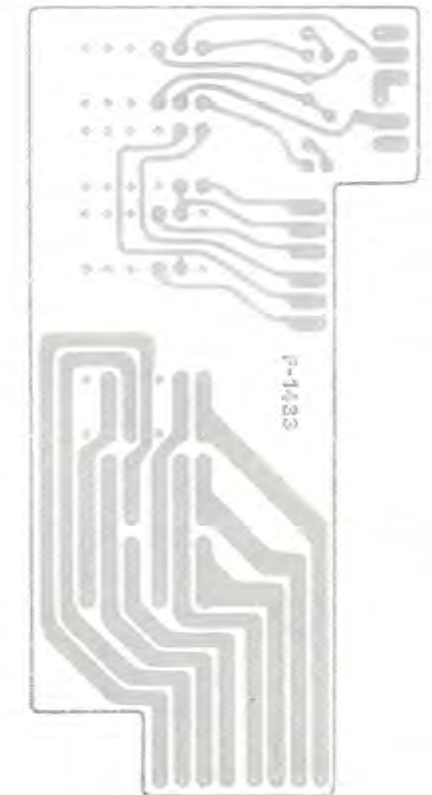

OTHER PARTS AND THEIR POSITION ON CHASSIS

W: Parts No. X: Parts Name Y: Stock No.

* Design and specifications subject to change without notice for improvements.

W	X	Y
R011	22Ω	0101220
R012	47Ω	0101470
R013	330Ω	0101331
R014	1.5kΩ	0101152
R015	2.2kΩ	0101222
R016	2.2kΩ	0101222
R631	220kΩ	0101224
R632	220kΩ	0101224
R633	100kΩ	0101104
R634	100kΩ	0101104
R851	820kΩ	0101824
R852	820kΩ	0101824
R853	0.47Ω	0153478
R854	0.47Ω	0153478
R855	0.47Ω	0153478
R856	0.47Ω	0153478
R857	470Ω	0171471
R858	470Ω	0171471
R859	560Ω	0171561
R860	560Ω	0171561
R861	560Ω	0171561
R862	560Ω	0171561
C015	0.01μF ^{+80%} / _{-20%} 500V CC.	0659011
C016	3300μF 100V EC.	0559831
C017	0.01μF ^{+80%} / _{-20%} 500V CC.	0659011
C018	1000μF 50V EC.	0559302
C019	0.01μF ^{+80%} / _{-20%} 1.4kV CC.	0657801
C020	0.01μF ^{+80%} / _{-20%} 500V CC.	0657223
C021	0.022μF ^{+80%} / _{-20%} 500V CC.	0657223
C022	0.022μF ^{+80%} / _{-20%} 500V CC.	0657223
C023	0.1μF ±10% 400V CC.	0595108
C024	0.1μF ±10% 400V CC.	0595108
C025~028	0.047μF × 4 ^{+80%} / _{-20%} 50V CC.	0800121
C851	2200μF 80V EC.	0559820
C852	2200μF 80V EC.	0559820
VR601	50kΩ(B) Mic Level Control	1005111
VR701,702	250kΩ(M, N) Balance Control	1010801
VR703,704	250kΩ(B) Volume Control	1010510
VR705,706	100kΩ(C) × 2 Bass Control	
VR707,708	100kΩ(C) × 2 Treble Control	
TR851	2SC793(R, Y, BL)	0305450,1,2
TR852		0305450,1,2
TR853		0305450,1,2
TR854		0305450,1,2
TR Socket		2030020
D004~007	5B2	0310660
T001	Power Transformer	4001110
L101	300Ω-75Ω FM Balloon	4290021
L303	AM Bar Antenna	4200380
M001		
S1	Selector Control	1104220
S16	Power Switch	1130350

W	X	Y
F001	Power Fuse 100-117V 5A 220-240V 3A	0431280 0431260
F002	Quick-Acting Fuse (Left) 4A	0433270
F003	Quick-Acting Fuse (Right) 4A Fuse Holder	0433270 2300070
PL001	7V 200mA 'PHONO 2' Indicator	0400154
PL002	7V 200mA 'PHONO 1' Indicator	0400155
PL003	7V 200mA 'FM' Indicator	0400141
PL004	7V 200mA 'AM' Indicator	0400153
PL005	7V 200mA 'AUX' Indicator	0400170
PL006	6V 100mA 'FM STEREO' Indicator	0400161
PL007	7V 300mA Signal Meter Lamp	0420040
PL013	6.3V 75mA Dial Pointer Lamp	0420020
PU001	Voltage Selector Plug Socket	2410090 2410080
PU002	Multi-Connector (For F-1267C)	2420030
PU003	Multi-Connector (For F-1180F)	2420020
PU004	Multi-Connector (For F-1430)	2420040
J001	Microphone Jack w/ switch	
J002	TAPE REC Phone Jack w/ switch	2430170
J003	TAPE PLAYBACK Phone Jack w/ switch	2430170
J004	Headphone Jack w/o switch	
J005	Headphone Jack w/ switch	2430170
J601	DIN socket	2430040
CO001	AC Outlet w/o switch	2450040
CO002	AC Outlet w/ switch FM Pack F-1309	2450040 7510340

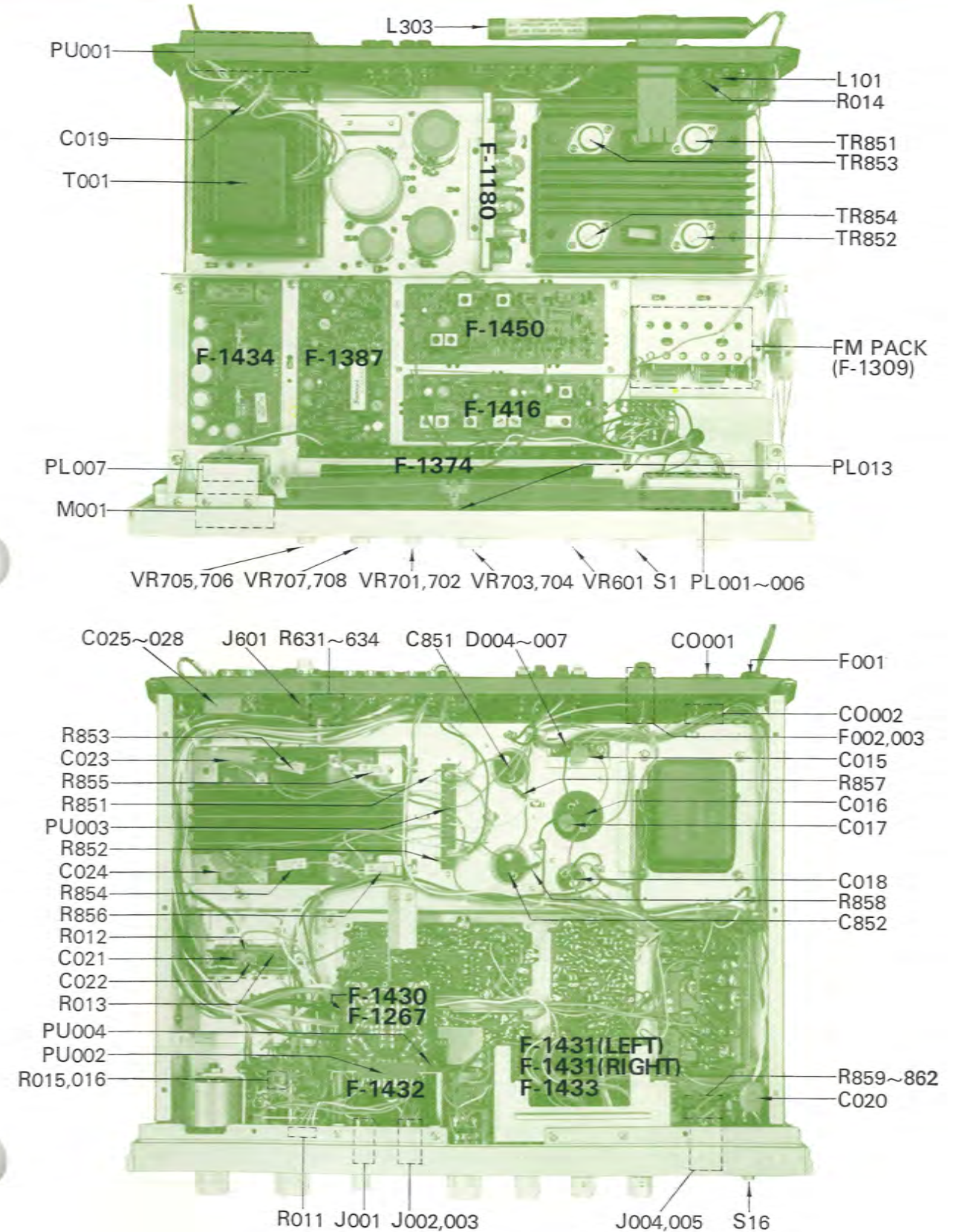



SANSUI ELECTRIC CO., LTD.
14-1, 2-chome, Izumi, Suginamiku, Tokyo 168, Japan.
TELEPHONE: (03) 323-1111 / TELEX: 232-2076

Stock No. 9207150

Printed in Japan (42020M)