



9

Technical Manual

AM/FM STEREO RECEIVER

RX-1603

ORIGINAL

CHASSIS LAYOUT (TOP VIEW)
CHASSIS-ANORDNUNG (OBERANSICHT)
INSTALLATION DE CHASSIS (VUE DE DESSUS)

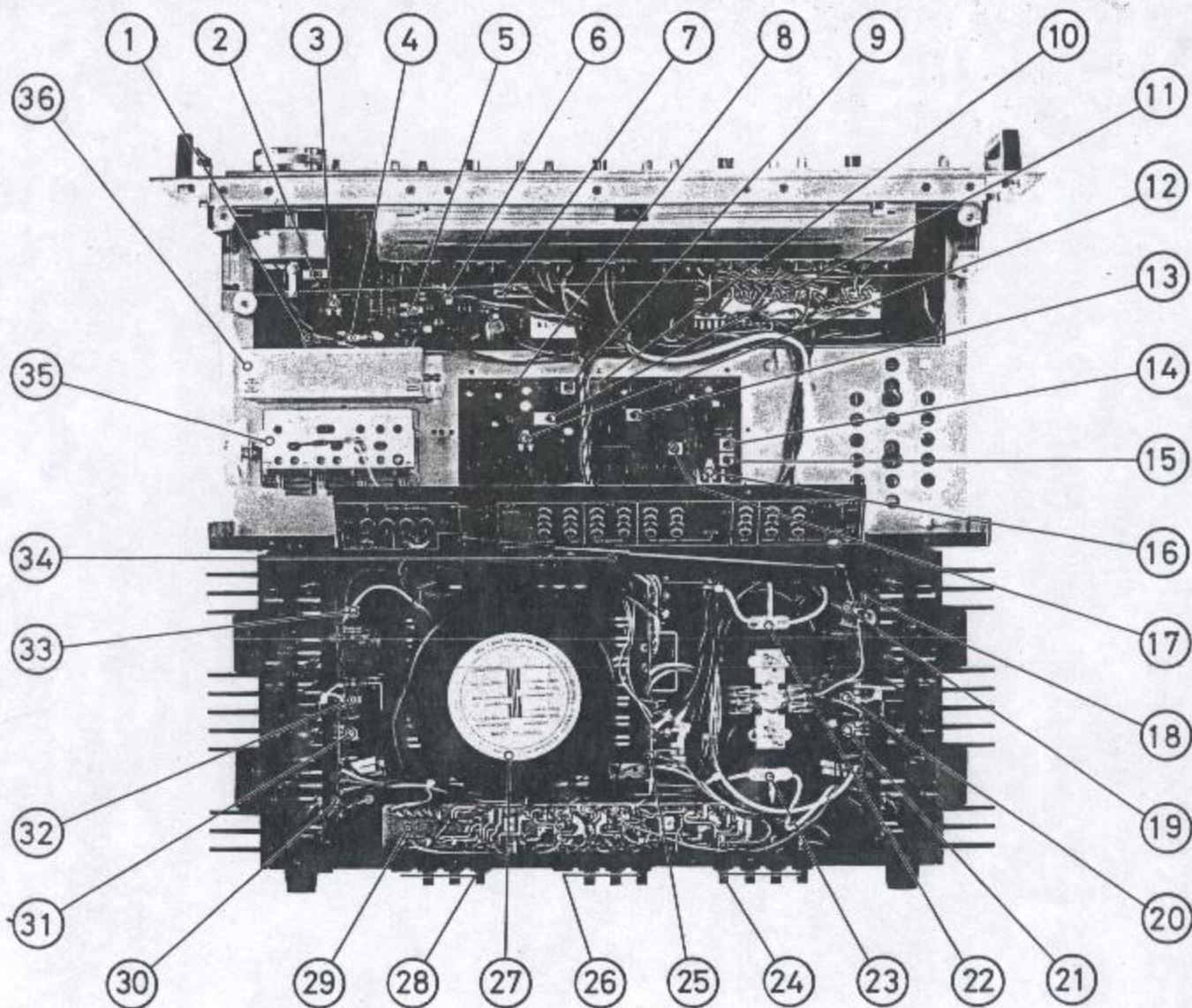

1. MPX DECODER CIRCUIT BOARD
2. FM DE-EMPHASIS (50 μ S - 75 μ S) SWITCH
3. VR301, FM AUTO-SWITCHING LEVEL ADJ
4. VR302, MPX SEPARATION ADJ
5. VR303, MPX SEPARATION (LEAKAGE) ADJ
6. VR304, FM MUTING LEVEL ADJ
7. RY301, FM MUTING RELAY
8. AM/FM IF AMP CIRCUIT BOARD
9. L103, AM OSC COIL
10. L105, AM RF COIL
11. L102, AM IFT, 1st
12. VR101, FM SIGNAL METER CAL
13. L104, AM IFT, 2nd
14. L114, FM DISC (SEC)
15. L113, FM DISC (PRI)
16. VR102, FM DISTORTION ADJ
17. L110, FM IFT
18. L-CH, MAIN AMP CIRCUIT BOARD

19. VR601, DC BALANCE ADJ, L-CH
20. VR602, BIAS ADJ, L-CH
21. VR603, OVERLOAD LEVEL ADJ, L-CH
22. C003, OB SMOOTHING CAPACITOR
23. C004, OB SMOOTHING CAPACITOR
24. SPEAKER-C TERMINAL STRIP
25. POWER SUPPLY (RECTIFIER) CIRCUIT BOARD
26. SPEAKER-B TERMINAL STRIP
27. T001, POWER TRANSFORMER
28. SPEAKER-A TERMINAL STRIP
29. SPEAKER RELAY CIRCUIT BOARD
30. R-CH MAIN AMP. CIRCUIT BOARD
31. VR603', OVERLOAD LEVEL ADJ, R-CH
32. VR602', BIAS ADJ, R-CH
33. VR601', DC BALANCE ADJ, R-CH
34. L004, AM ANTENNA COIL
35. AM/FM FRONT END
36. PHONO AMP CIRCUIT BLOCK

CHASSIS LAYOUT (BOTTOM VIEW)
CHASSIS-ANORDNUNG (UNTERANSICHT)
INSTALLATION DE CHASSIS (VUE DE DESSOUS)

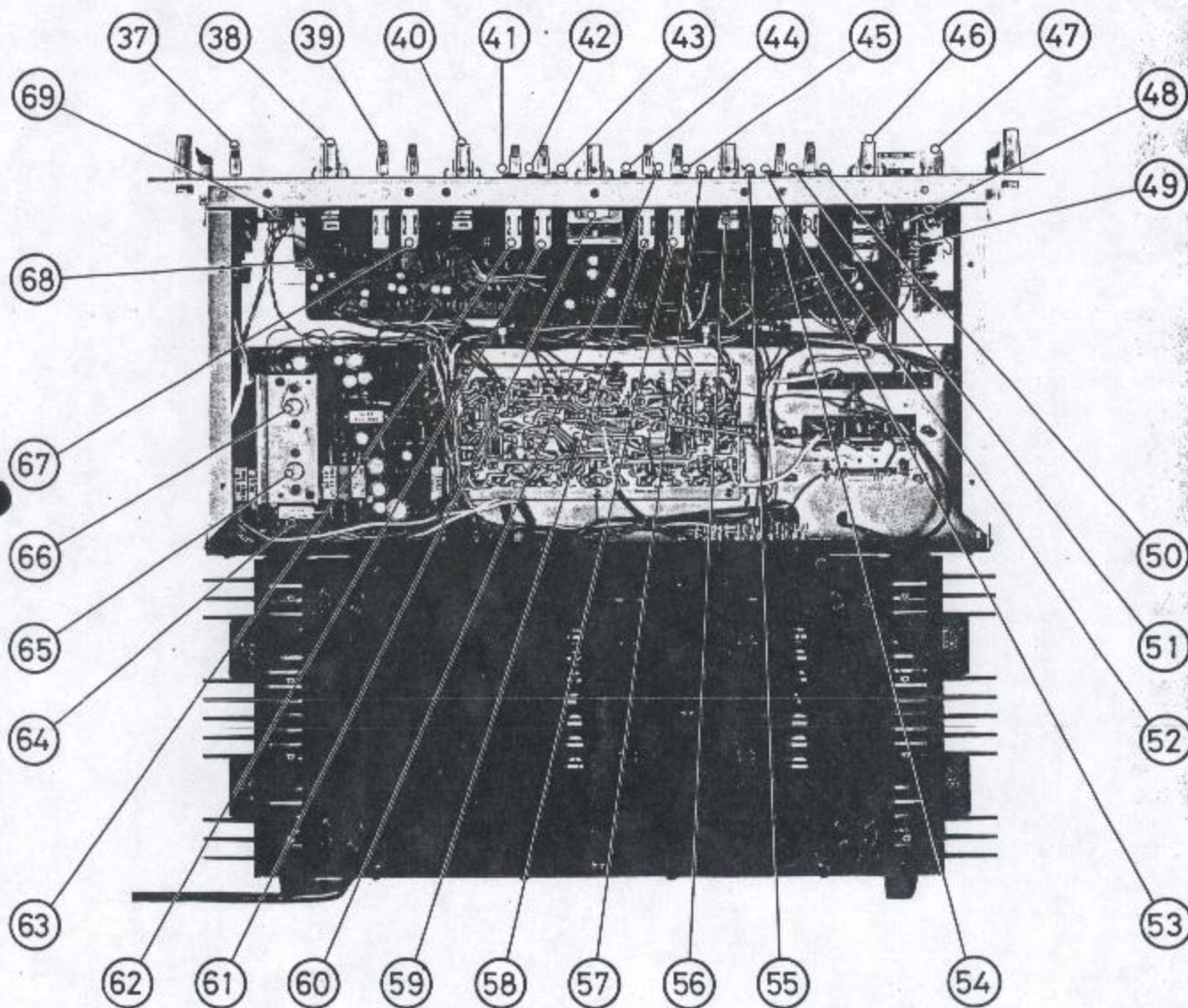

- | | |
|----------------------------------|---|
| 37. POWER SWITCH | 54. LOUDNESS SWITCH |
| 38. BASS CONTROL | 55. FM MUTING SWITCH |
| 39. BASS TURNOVER SWITCH | 56. BALANCE CONTROL |
| 40. TREBLE CONTROL | 57. FM SWITCH |
| 41. SPEAKER-A SWITCH | 58. TAPE MONITOR SWITCH |
| 42. SPEAKER-B SWITCH | 59. TAPE COPY SWITCH |
| 43. SPEAKER-C SWITCH | 60. PHONO-2 SWITCH |
| 44. PHONO-1 SWITCH | 61. MODE SWITCH |
| 45. AM SWITCH | 62. HIGH FILTER SWITCH |
| 46. VOLUME CONTROL | 63. LOW FILTER SWITCH |
| 47. MIC MIXING LEVEL CONTROL | 64. POWER SUPPLY (STABILIZER) CIRCUIT BOARD |
| 48. MIC JACK | 65. Q901, ♂B STABILIZER |
| 49. MIC MIXING AMP CIRCUIT BOARD | 66. Q902, ♂B STABILIZER |
| 50. FM DE-EMPHASIS (25μS) SWITCH | 67. TREBLE TURNOVER SWITCH |
| 51. FM MULTIPATH SWITCH | 68. TONE CONTROL CIRCUIT BOARD |
| 52. AUDIO MUTING SWITCH | 69. PHONE JACK |
| 53. FM HI-BLEND SWITCH | |

AM ALIGNMENT PROCEDURE

AM-ABGLEICH

PROCEDURE D'ALIGNEMENT AM

Instruments: AM Signal Generator and AC VTVM.

Notes: Set Function Selector switch to AM.

Input signal must be kept as low as possible to avoid AGC action.

Step	Generator		Tuning Dial Setting	Output Indicator Connected to	Adjust	Adjust for
	Coupling	Frequency				
1	Pin No. 12 (on IF board) through a 0.01 mfd capacitor.	455kHz (400Hz 30% mod.)	Non interfering at low end of scale.	AC VTVM to TAPE OUT jack.	L104 and L102 (on IF board)	Maximum reading on VTVM.
2	Test Loop Radiate signal into ferrite loopstick antenna.	600kHz (400Hz 30% mod.)	600kHz		L103 (OSC) L105 (RF) (on IF board) and L004 ANT. Coil.	
3		1400kHz (400 Hz 30% mod.)	1400kHz		CT7 (OSC), CT6 (RF) CT5 (ANT) Trim (on Front-end)	
4	Repeat steps 2 and 3 until no further improvement is noticed.					

Instrumente: AM-Meßsender und Wechselstrom-Röhrenvoltmeter

Zur Beachtung: Funktionswählschalter auf AM stellen.

Das Eingangssignal muß so klein wie möglich gehalten werden, um Ansprechen der automatischen Schwundregelung zu vermeiden.

Schritt	Meßsender		Abstimmungskalen-einstellung	Ausgangsanzeige angeschlossen an	Abgleich	Abgleich auf
	Anschluß	Frequenz				
1	Steckerstift 12 (auf ZF-Leiterplatte) über 0,01 mF-Kondensator	455 kHz (400Hz 30% moduliert)	Keine Interferenz am unteren Skalenende	Wechselstrom-Röhrenvoltmeter an Buchse TAPE OUT	L104 und L102 (auf ZF-Leiterplatte)	Maximalanzeige am Röhrenvoltmeter
2	Meßschleife. Signal in Ferritrahmenantenne einspeisen.	600kHz (400Hz 30% moduliert)	600kHz		L103 (OSZ) L105 (HF) (auf ZF-Leiterplatte) und L004 Antennenspule	
3		1400kHz (400 Hz 30% moduliert)	1400kHz		CT7 (OSZ) CT6 (HF) CT5 (Ant.) Trimmer (in der Eingangsstufe)	
4	Schritt 2 und 3 wiederholen, bis keine weitere Verbesserung eintritt.					

struments: Générateur de signal AM et voltmètre électronique (VTVM AC)

otes: Régler le commutateur de sélecteur de fonction sur AM. Le signal d'entrée doit être maintenu aussi bas que possible afin d'éviter l'action AGC.

Point	Générateur		Ecran d'accord	Indicateur de sortie connecté à	Réglage	Réglage pour
	Couplage	Fréquence				
1	Broche No. 12 (sur le plaquette IF) par l'intermédiaire d'un condensateur de 0,01mfd.	455kHz (400Hz 30% mod.)	Non interférence à l'extrémité inférieure de l'échelle.	Voltmètre électronique sur le jack TAPE OUT.	L104 et L102 (sur le plaquette IF)	Lecture maximum sur le voltmètre électronique
2	Boucle de mesure Envoie le signal sur l'antenne ferrite à boucle.	600kHz (400 Hz 30% mod.)	600kHz		L103 (OSC) L105 (RF) (sur le plaquette IF) et L004 ANT. bobine.	
3		1400kHz (400 Hz 30% mod.)	1400kHz		CT7 (OSC) CT6 (RF) CT5 (ANT) de correction (sur l'extrémité avant)	
4	Répéter les points 2 et 3 jusqu'à ce qu'il ne puisse être remarqué d'amélioration supplémentaire.					

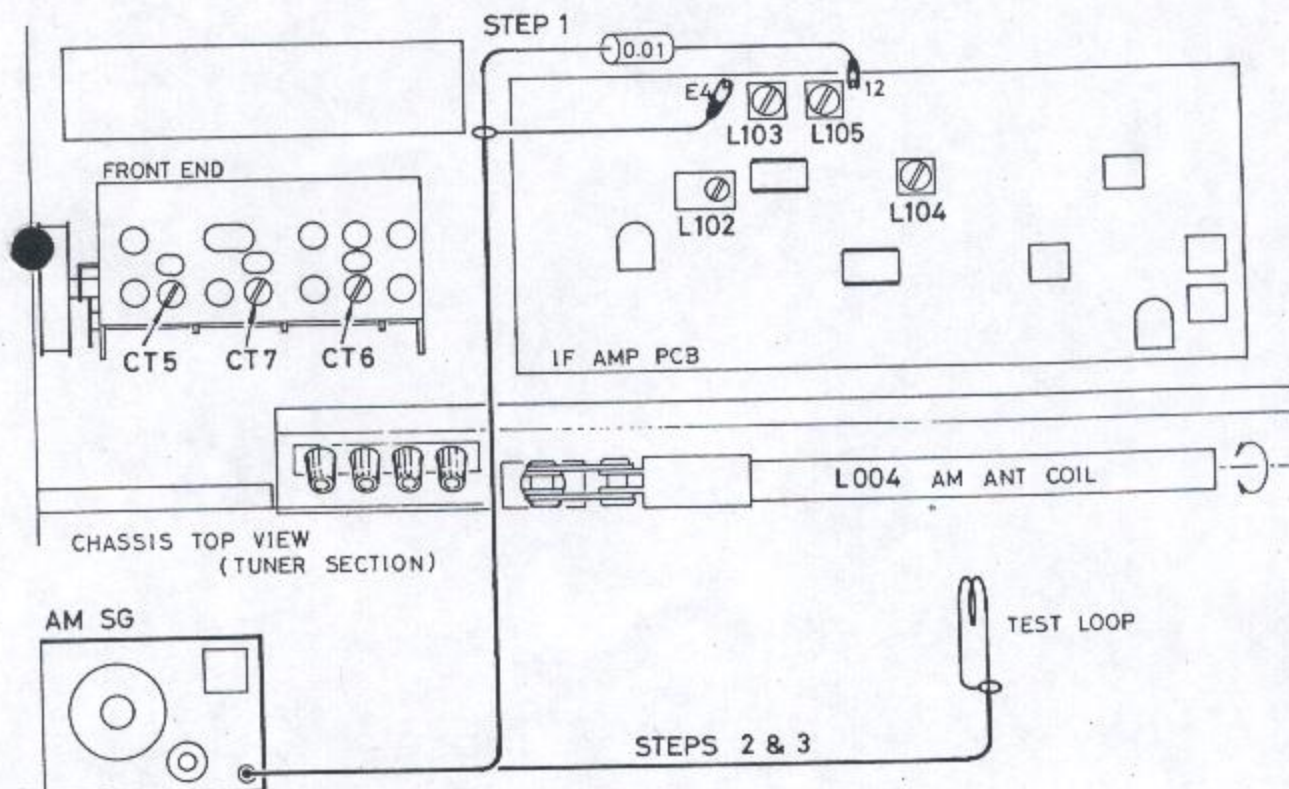
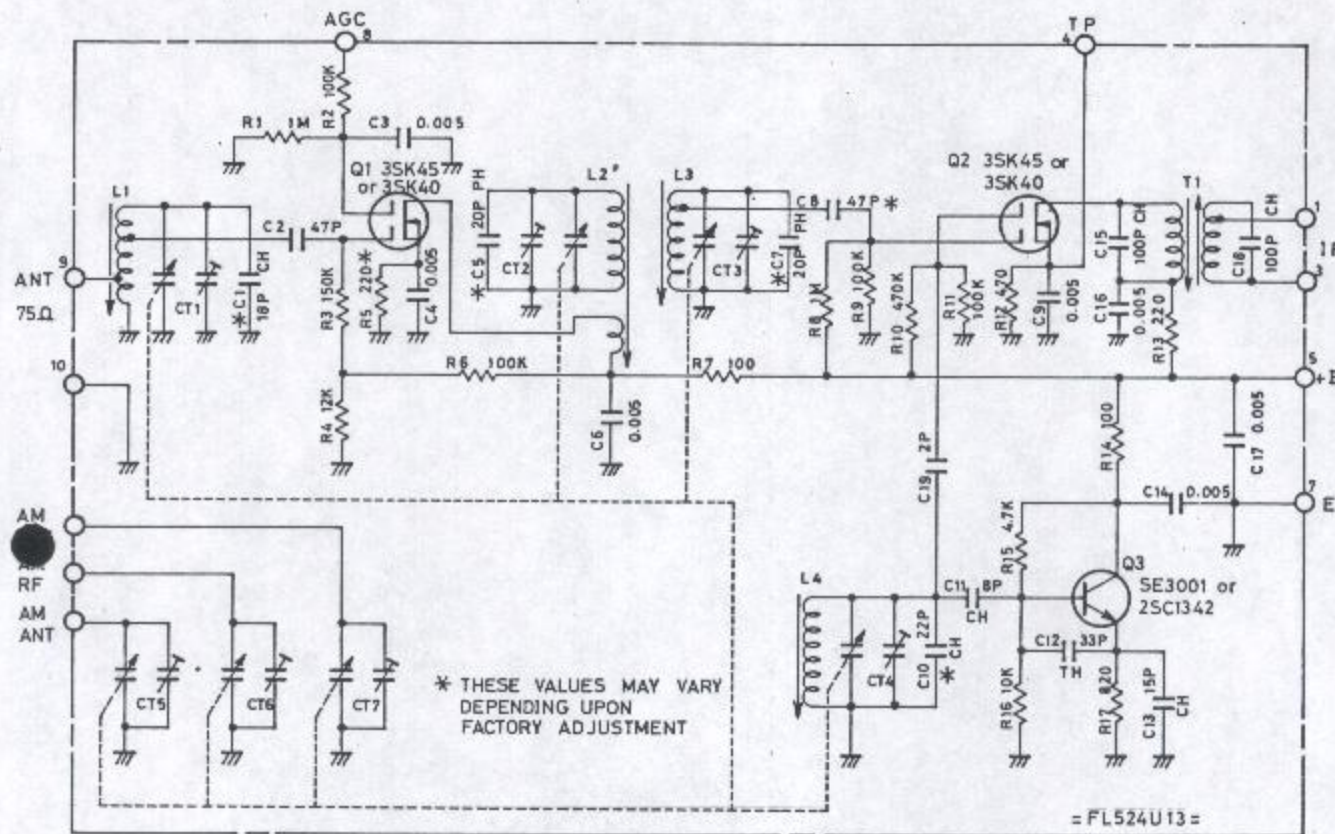
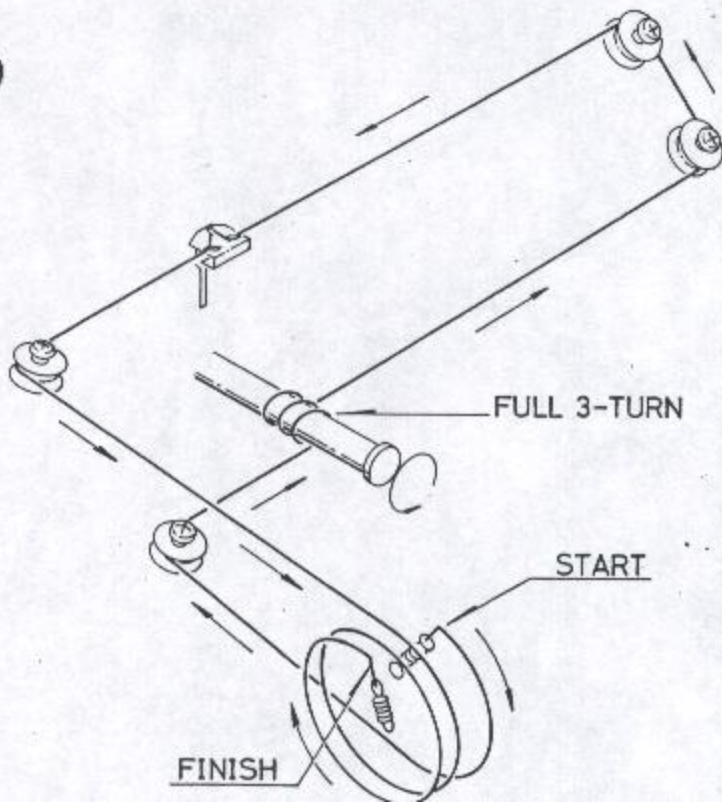

FIG. 4. AM IF AND RF ALIGNMENT HOOK-UP
 ABB. 4. MESSANSCHLUSS ZUM AM-ZF- UND AM-HF-ABGLEICH
 FIG. 4. SCHEMA DE MONTAGE D'ALIGNEMENT AM IF ET RF

FRONT END SCHEMATIC DIAGRAM EINGANGSSTUFE-SCHALTUNGSSCHEMA DIAGRAMME SCHEMATIQUE DE L'EXTREMITE AVANT



DIAL STRINGING DIAGRAM SKALENANTRIEBSSCHEMA DIAGRAMME DES CABLE D'ENTRAINEMENT



Note:
Carry out stringing with the front end set at VC minimum.

Zur Beachtung:
Antriebsseil mit dem Drehko in Minimumstellung verlegen.

Note:
Effectuer le câblage avec l'extrémité avant réglée au minimum.

REPAIR PA REPARATU LISTE DES

Schematic Location	TRANSIST
	Q101, 102, 107, 108, 301, 304, 305, 701, 905, 910, 912, 913
	Q103, 104, 105, 106, 109, 110, 111, 112
	Q302, 303
	Q401, 402, 403, 404, 501, 502, 503, 504, 505, 506, 507, 508, 509, 510
	Q405, 406, 409, 410, 601, 602, 611, 906, 911
	Q407, 409
	Q603
	Q604, 612, 613, 908
	Q605, 607
	Q606
	Q608
	Q609
	Q610
	Q702, 703, 704
	Q901, 902
	Q903
	Q904
	Q914
	Q001, 002, 003, 004, 005, 006, 007, 008
	D101, 102, 103, 104, 105, 108, 109, 110, 910
	D106, 301, 302, 303, 305, 701, 702, 703, 704, 904, 906, 912
	D111, 112
	D304
	D401, 402, 603
	D107, 601, 602, 905
	D901, 903
	D902
	D907, 908, 910
	D909
	D911
	D001, 011, 012
	D002, 003, 004, 005, 006, 007, 008, 009, 010
	D013
	IC101
	IC102
	IC301
	IC801, 802

PARTS LIST

TURTEILLISTE

DES PIÈCES DE RECHANGE

Part No.	Description
RESISTORS, DIODES AND IC'S	
301201115	2SC828, AM Audio Amp, FM Muting, Overload Protection, etc.
301201117	2SC829, FM IF Amp, etc.
301201134	2SC1327, FM MPX Audio Amp
301201156	2SC1222(E), Phono Amp, Tone Amp, etc.
301001134	2SA750-1, Phono Amp, Differential Amp, etc.
301201157	2SC1400, Phono Amp
301001142	2SA912, Main Amp Bias Compensator
301301137	2SD571, Limiter, Stabilizer, etc.
301201164	2SC1885, Predriver
301201161	2SC1628, Driver
301001138	2SA818, Driver
301201167	2SC1669, Driver
301001144	2SA839, Driver
301201155	2SC1318, Speaker Relay Driver
301201141	2SC1444, Stabilizer
301201143	2SC1509, Stabilizer, ⊕B
301001128	2SA777, Stabilizer, ⊕B
301101123	2SB605, Power Supply Relay Driver
301201166	2SC1586, Power Amp
300111008	1K188, AM Det, FM AGC Rect, etc.
300111012	TD81515
300111010	1S2473, FM Det
300313018	WZ-140, Regulator, 14V
300212008	KB-165, Temperature Compensator
300212002	KB-265, Temperature Compensator, etc.
300313013	WZ-120, Regulator, 12V
300313019	WZ-350, Regulator, 35V
300919016	SM-1-08, Rectifier
300515001	2SF656, Thyristor
300919030	S15VB, Rectifier
300414014	SEL-105RC, Mic, FM ST Ind, etc.
300414015	SEL-305GC, Function Ind.
300212010	SV-04F, Temperature Compensator
303452163	μPC1021C, AM Conv, and IF Amp
303452156	HA1137W, FM IF Amp
303452165	HA1196, FM MPX Decoder
303452164	μPC1024H, Mic Amp

Schematic Location	Part No.	Description
VARIABLE RESISTORS		
VR101, 102	510502154	50KB, FM Signal Meter Cal, FM Dist Adj
VR301, 303, 304	510502155	100KB, FM Auto-Switch Adj, Muting Adj, etc.
VR302	510502153	10KB, 19kHz Adj
VR501	525101143	100KBH x 2, Balance Control
VR502	525121137	100KBT x 2 + 100KC x 2, Volume Control
VR503, 504	525101140	50KB x 2, Treble Control, Bass Control
VR601, 602	510502145	1KB, DC Balance Adj, Bias Adj
VR603	510502146	5KB, Overload Protection Level Adj
VR801 (w/S22)	525101135	50KB, Mic Level Control with Mic Switch
COILS AND TRANSFORMERS		
L101, 106, 107, 003	226501124	RF Choke, 2μH
L102	229101183	AM IFT, 1st, 455kHz Tune
L103	223301123	AM Local Osc Coil
L104	225301127	AM IFT, 2nd, 455kHz Tune
L105	226501130	AM RF Coil
L108	228641119	AM Whistle Filter
L109, 111, 301, 901, 902, 903, 002	226501123	RF Choke, 47μH (470)
L110	226501122	FM IFT, 10.7MHz
L112	226501137	Quadrature Coil
L113	225501125	FM Disc (Pri)
L114	225501127	FM Disc (Sec)
L302	228641118	FM Low Pass Filter
L001	222391131	AM ANT Coil Ass'y
L004	226501121	FM ANT Matching Transformer
T001	205001413	Power Transformer (Multi-voltage)
	206001413	Power Transformer (220V/240V)
	204001413	Power Transformer (100V/120V)
SWITCHES		
S1	601011273	Mode Selector
S2, 7	611001238	Bass Turnover, Low Cut Filter
S3, 15	611001237	Treble Turnover, Tape Monitor
S4, 5, 6 (1 set)	614030814	Speaker Selector
S8	611001242	High Cut Filter
S9, 10, 11, 12 (1 set)	614051014	Function Selector
S14	611001245	Tape Copy
S16, 17, 18, 19 (1 set)	614040820	Muting, Multipath, etc.
S20, 21	611001241	Loudness, Audio Muting
S22	-	See VR801.
S23	611001247*	Power Supply
S24, 25	613000022	Pre-Main, Phono Sensitivity Selector
S26	613000024	FM Deemphasis 50/75μS Selector
		*611001248 for SEMKO specification.

MAIN AMP (L-CH) CIRCUIT BOARD DIAGRAM
SCHALTBILD DES HAUPTVERSTÄRKERS (L-KANAL)
DIAGRAMME DE PLAQUETTE DE CIRCUIT DE CANAL
GAUCHE DE L'AMP. PRINCIPAL

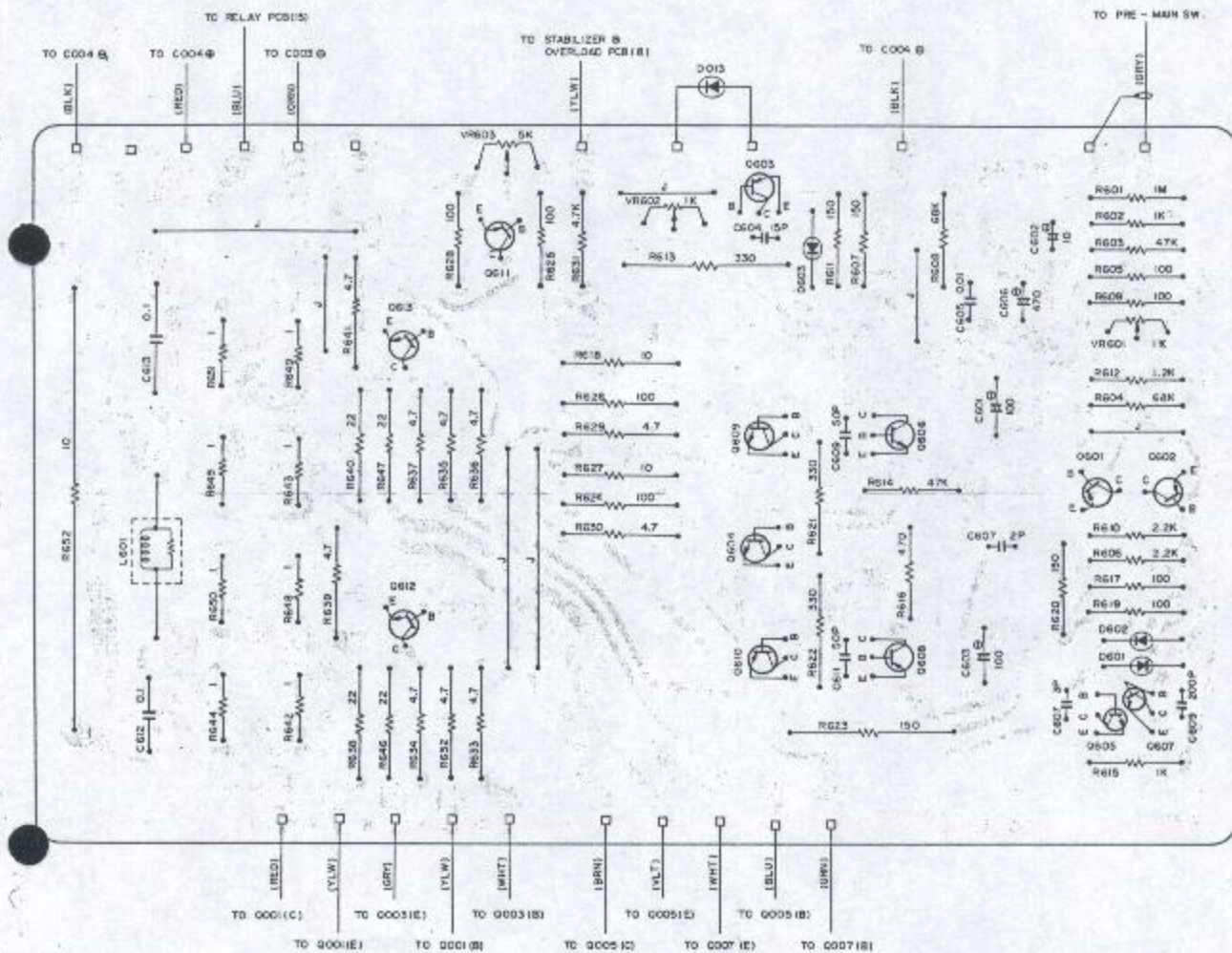

POWER SUPPLY (RECTIFIER) CIRCUIT BOARD DIAGRAM
SCHALTBILD DES NETZTEILS (GLEICHRICHTER)
DIAGRAMME DE PLAQUETTE DE CIRCUIT D'ALIMENTATION (REDRESSEUR)

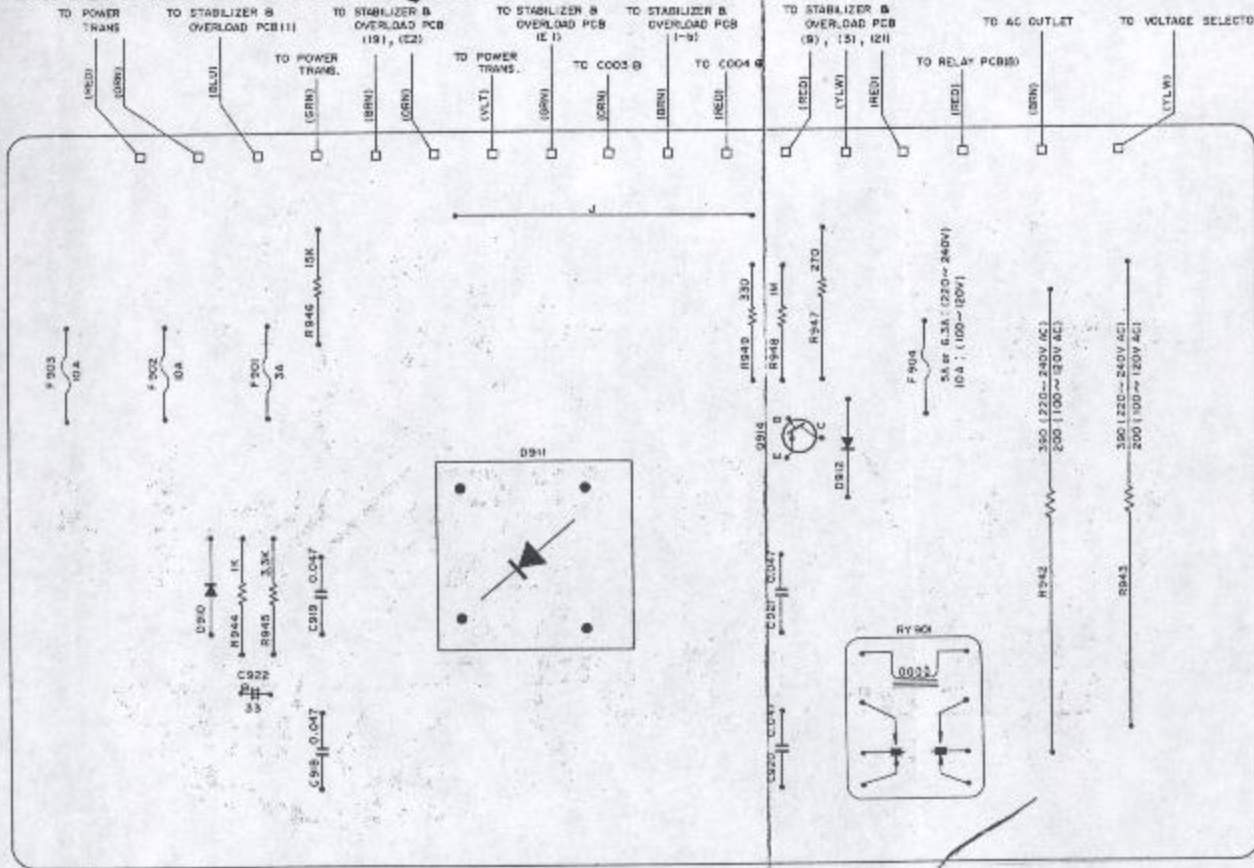

AM & FM IF CIRCUIT BOARD DIAGRAM
SCHALTBILD DES MW/UKW-ZF-VERSTÄRKERS
DIAGRAMME DE PLAQUETTE DE CIRCUIT AM & FM IF

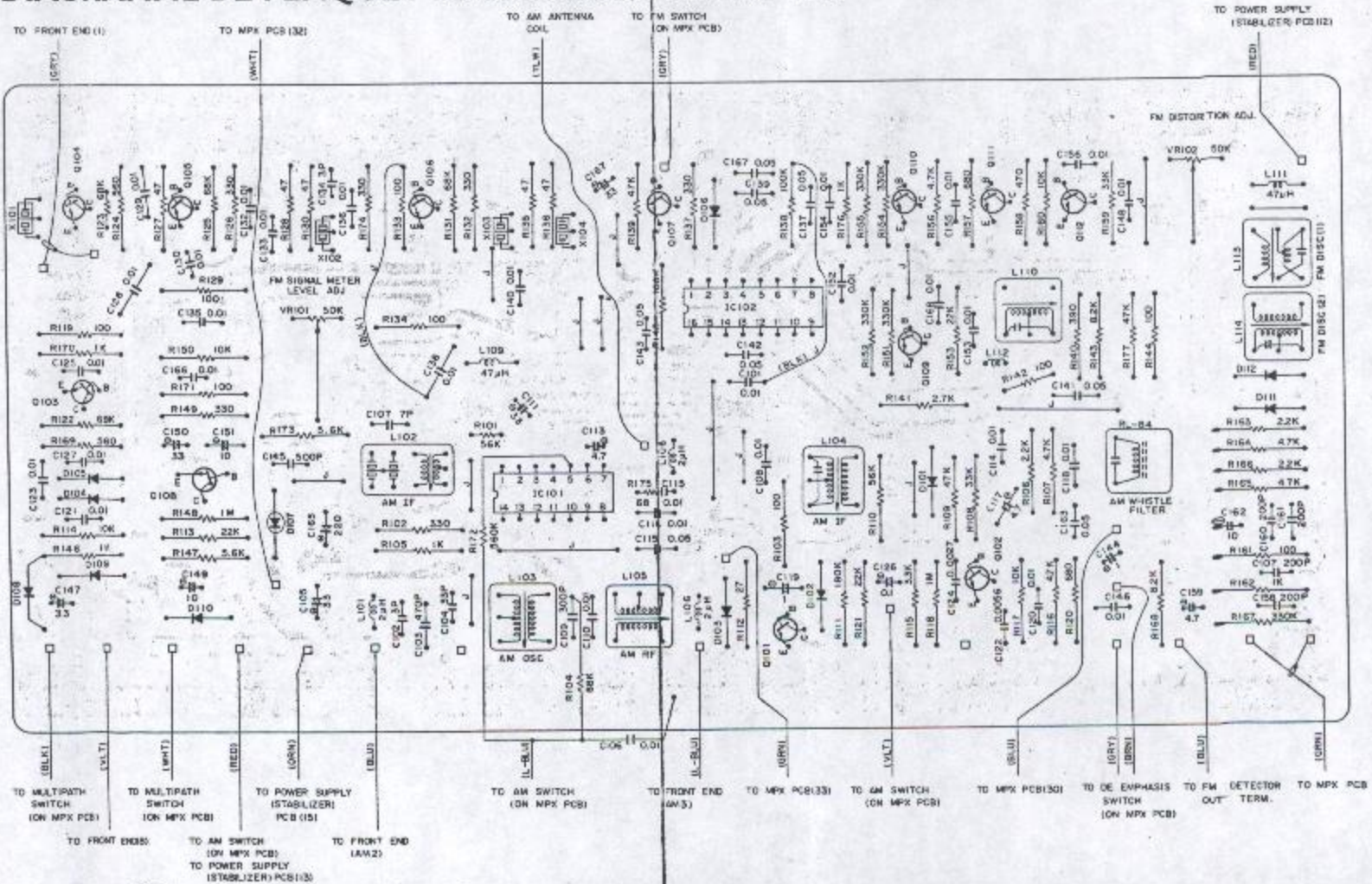

SCHEMATIC DIAGRAM SCHALTUNGSSCHEMA DIAGRAMME SCHEMATIQUE

This Schematic Diagram is applicable to the units with the following Serial No. and Serial No. beginning: NA53001 R28056

Dieses Schaltungsschema gilt für Geräte ab folgenden Seriennummern: Seriennummer, Anfang: NA53001 R28056

Ce diagramme schématique est applicable aux unités ayant le No. de série suivant. Numéro de série commençant par: NA53001 R28056

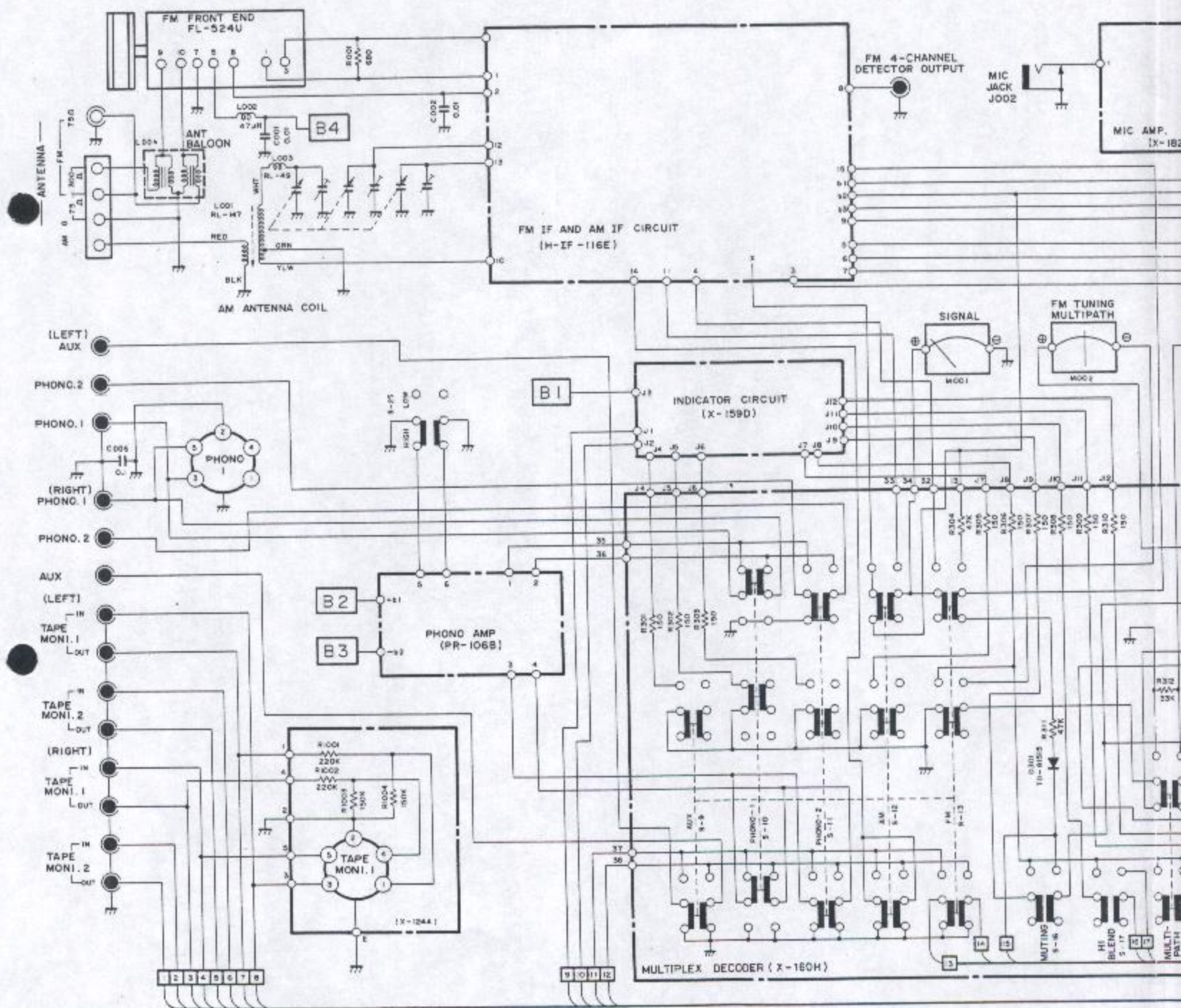

No. and onward.

suiwant.

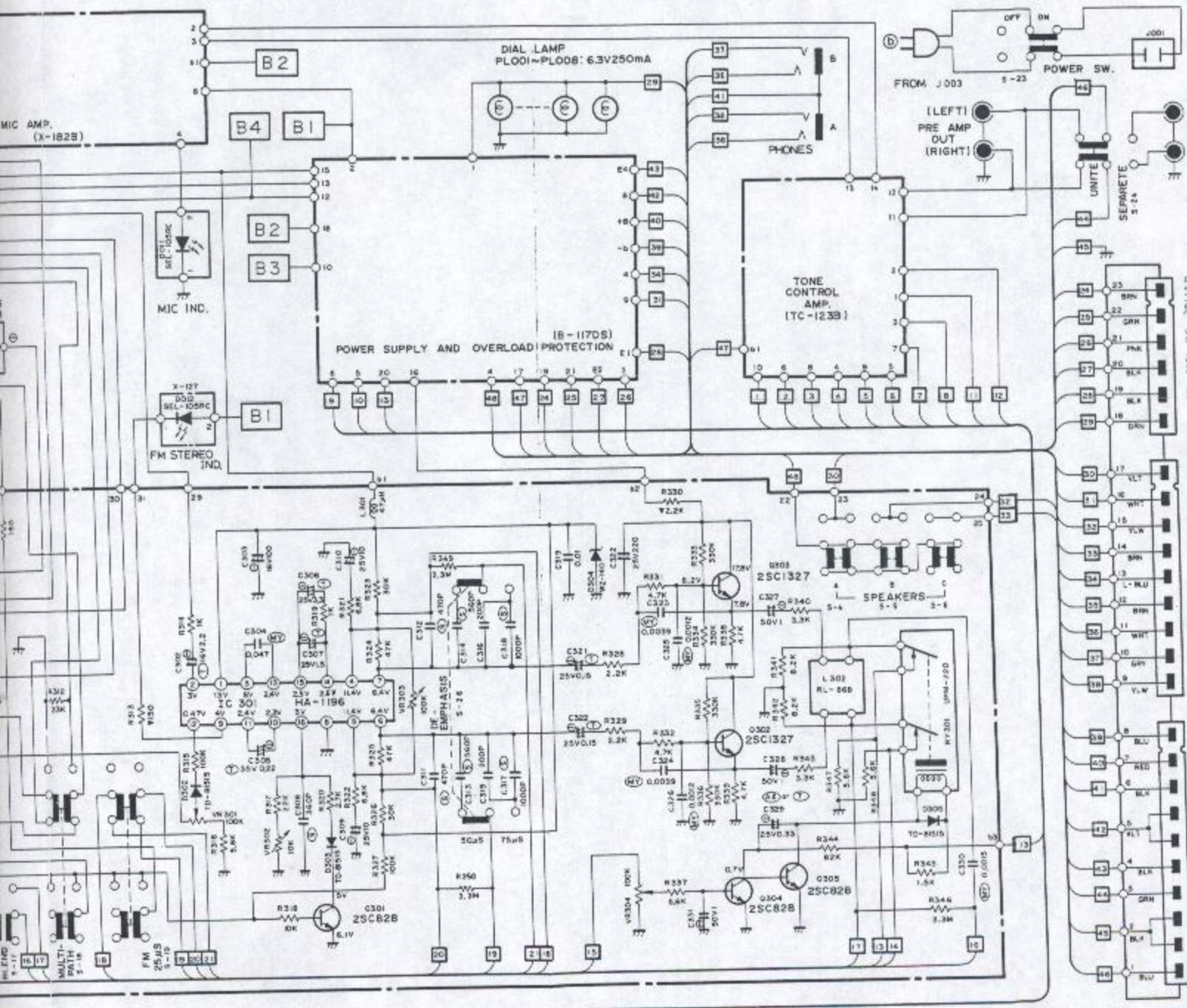

ROTEL RX-1603 TUNER / PREAMP CIRCUIT DIAGRAM

Datel PX 1603

Part - RX 1603

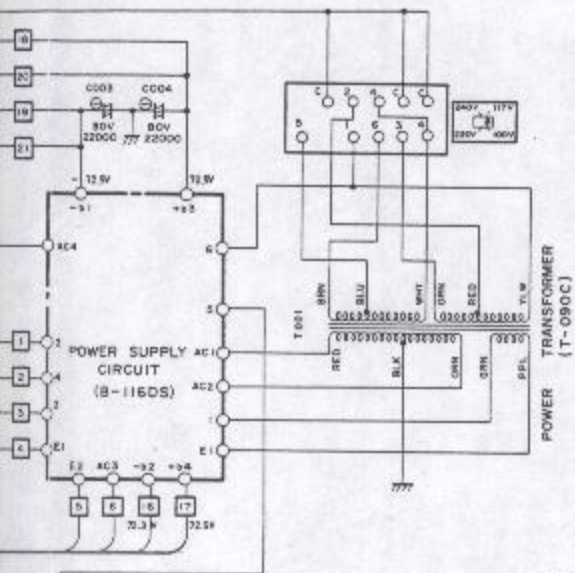

- RESISTORS**
 5% --- TOLERANCE UNLESS OTHERWISE NOTED.
 K --- KILO OHM.
 M --- MEGA OHM.
 --- COMPOSITION RESISTORS 1/2 WATT.
 NONMARK --- LOW NOISE TYPE CARBON RESISTORS 1/4 WATT.
- CAPACITORS**
 MY --- MYLAR FILM CAPACITORS.
 AL --- SINTERED ALUMINUM SOLID ELECTROLYTIC CAPACITORS (ALSIOM).
 P --- POLYESTER FILM CAPACITORS.
 T --- TANTALUM CAPACITORS.
 LN --- LOW NOISE TYPE CAPACITORS.
 E --- ELECTROLYTIC CAPACITORS.
 TC --- TEMPERATURE COEFFICIENT CAPACITORS.
 NONMARK --- CERAMIC CAPACITORS.
- UNLESS OTHERWISE NOTED IN SCHEMATIC ALL CAPACITANCE VALUES ARE EXPRESSED IN MFD.
 - VOLTAGE READINGS WITH VTVM FROM THE POINT SHOWN TO THE CHASSIS GROUND (LINE VOLTAGE 120VOLTS).
 - VOLTAGE READING MAY VARY ±20%.
 - --- POLYPROPYLENE FILM CAPACITORS.

ITEM	SCHMATIC LOCATION LAST
FM IF AND AM IF CIRCUIT	R177 C168
MULTIPLEX DECODER	R350 C331
PHONO AMP.	R438 C435
TOPE CONTROL AMP.	R596 C564
MAIN AMP.	R652 C614
RELAY CIRCUIT	R722 C702
MIC AMP.	R817 C816
POWER SUPPLY CIRCUIT	R949 C922
CHASSIS	R001 C006

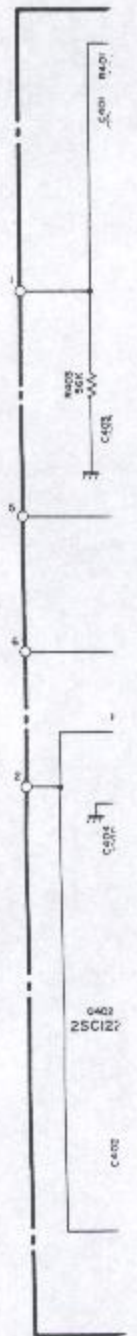
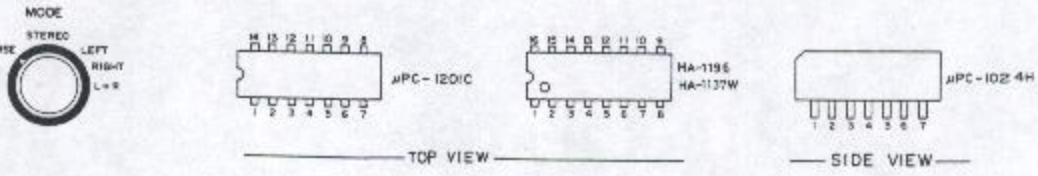
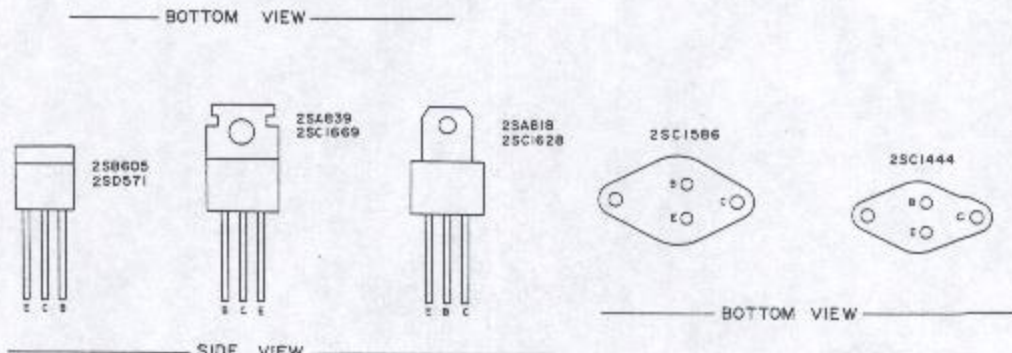
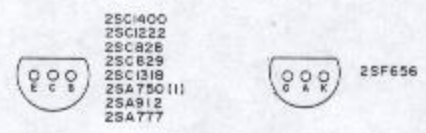
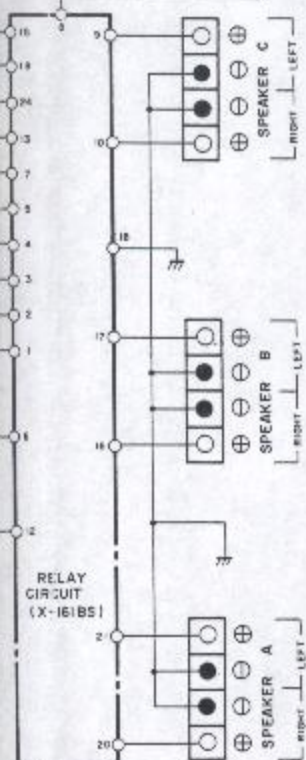

Rotel RX 1603

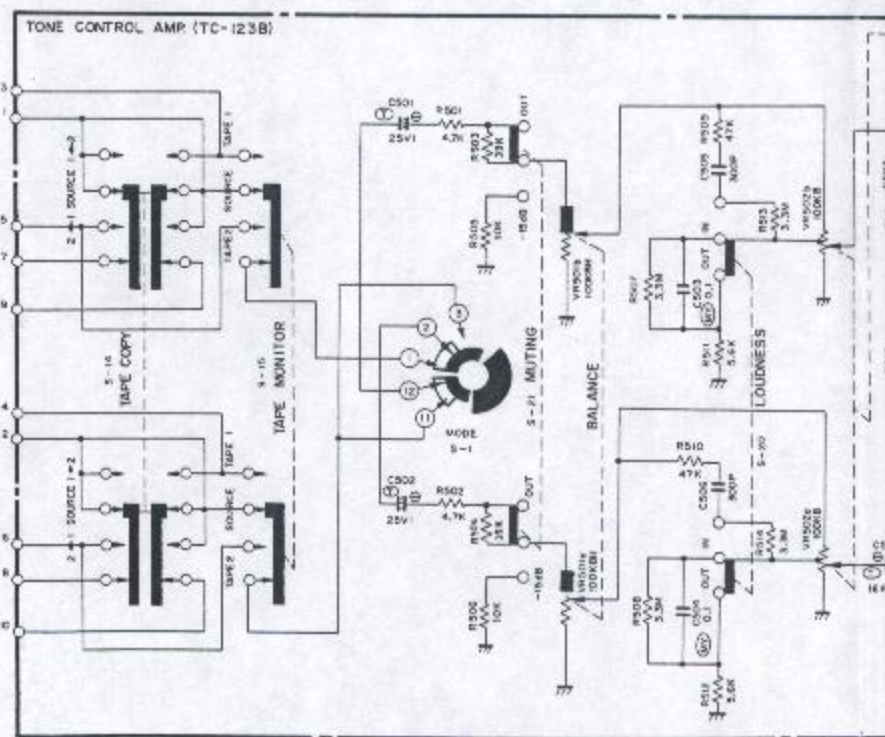
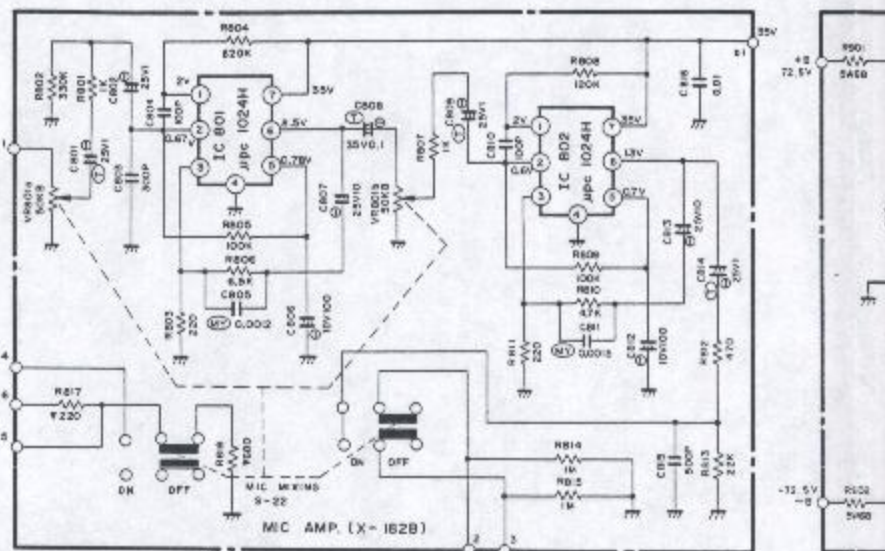
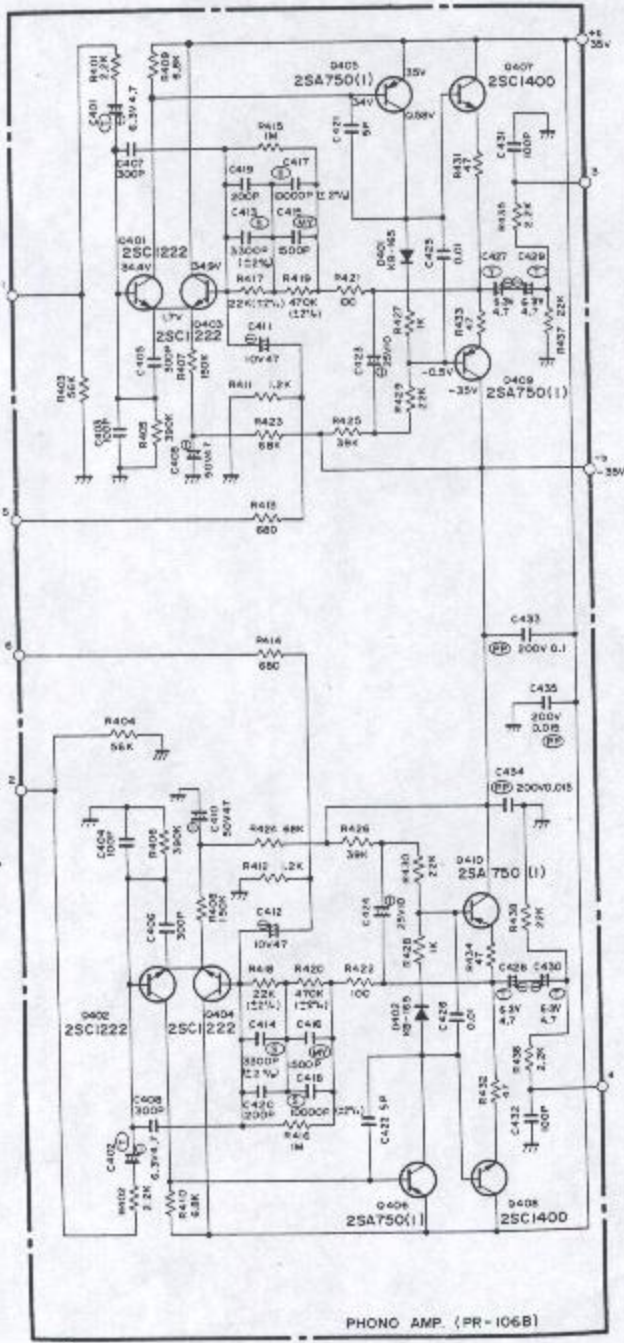

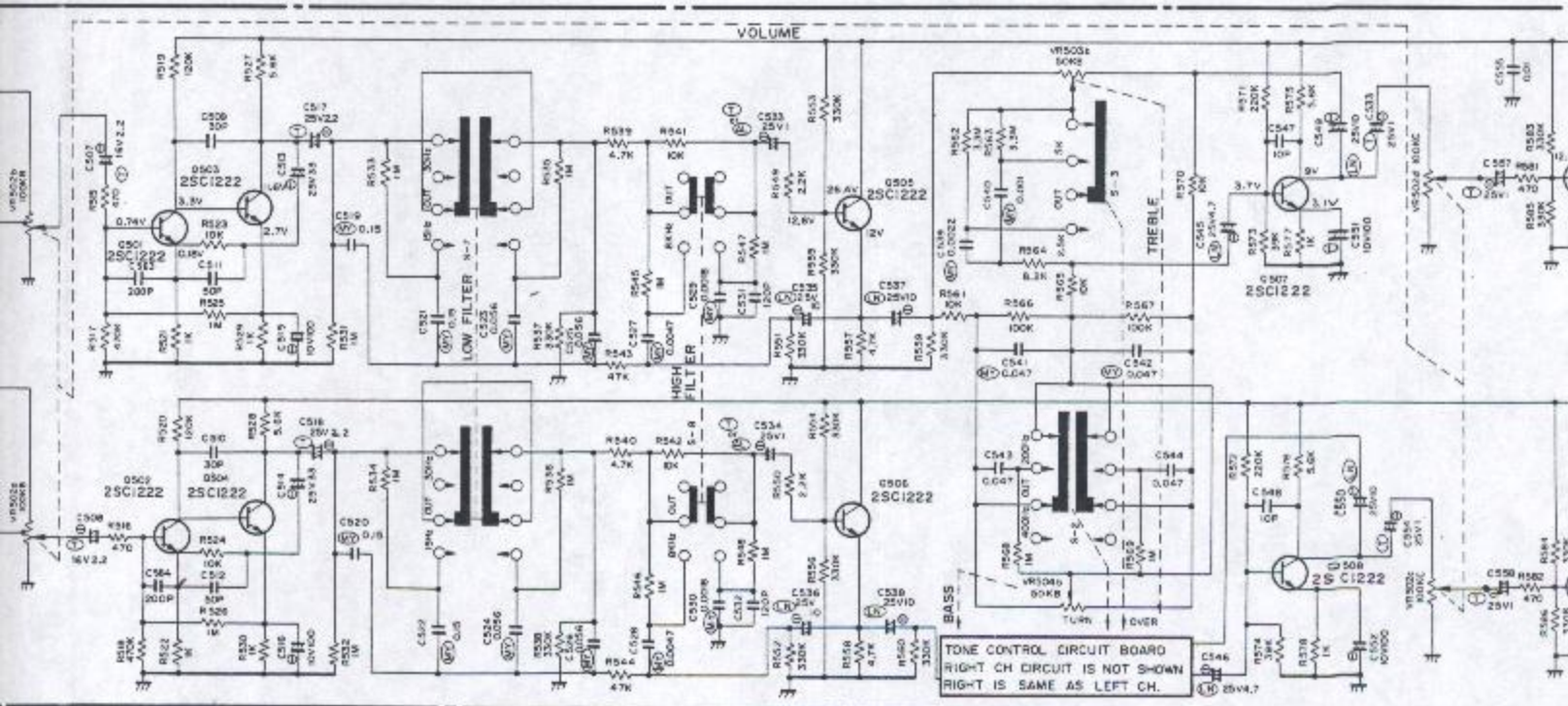
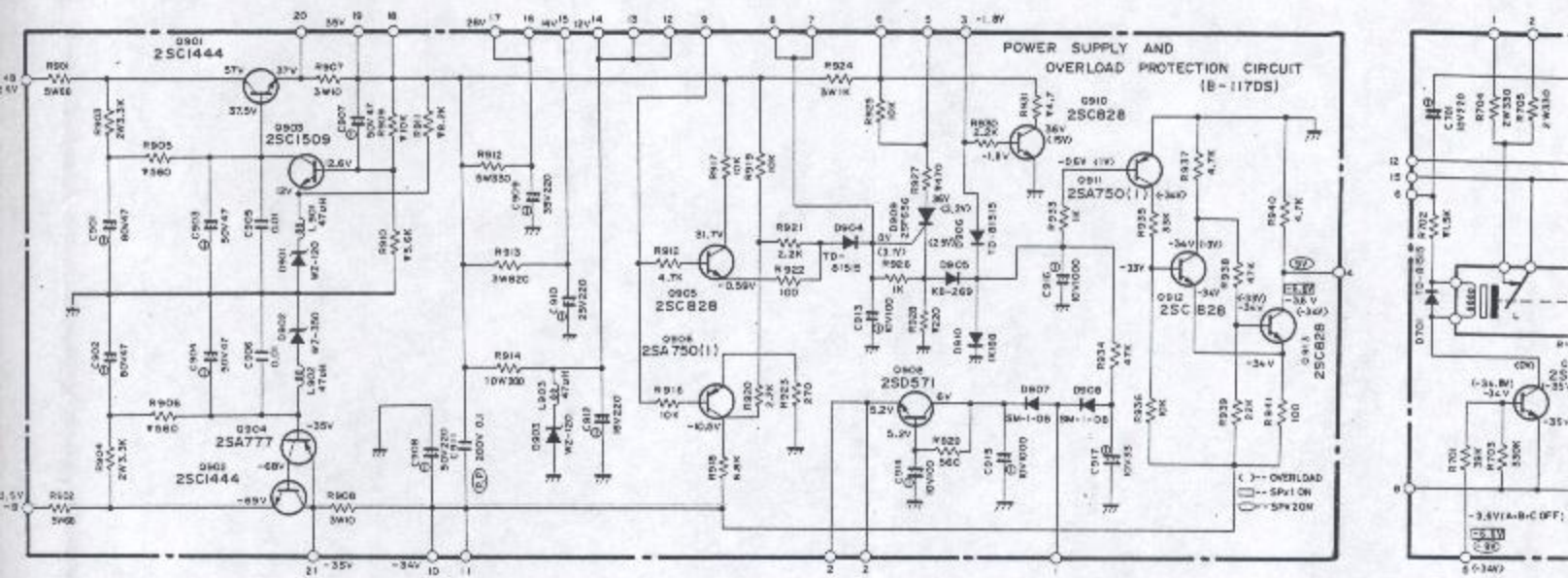

Bozel PX 160.3

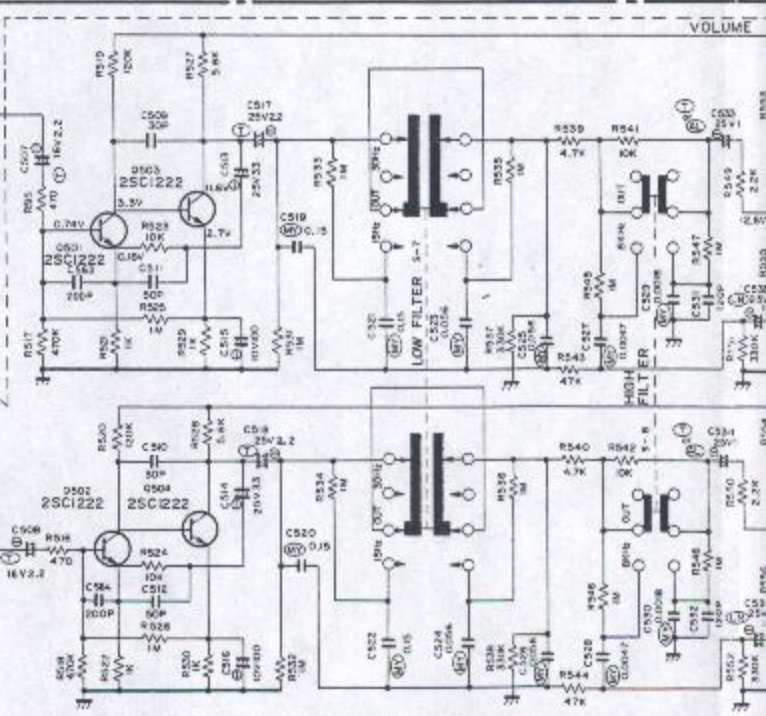
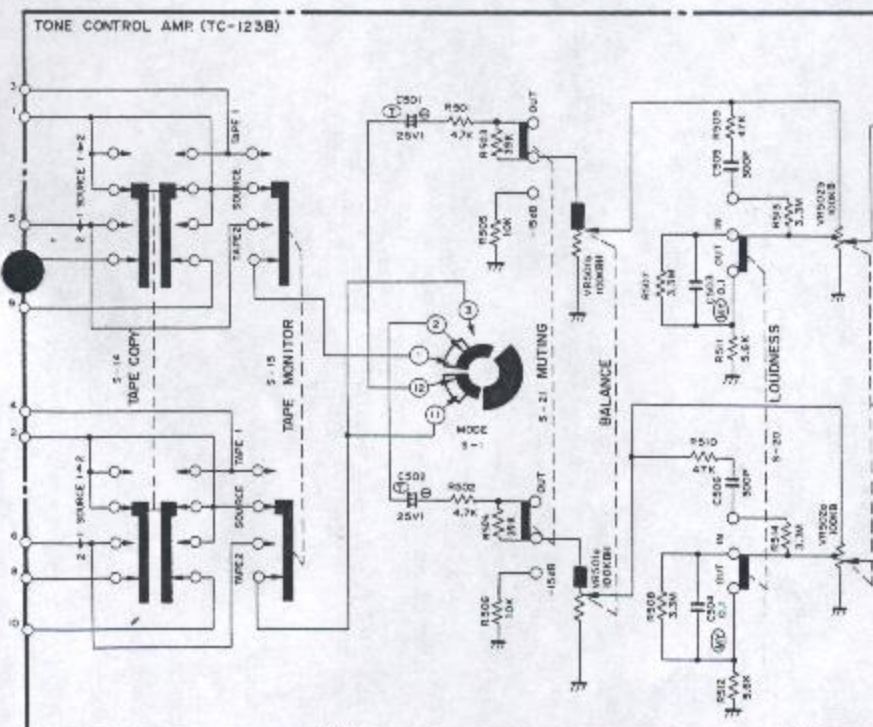
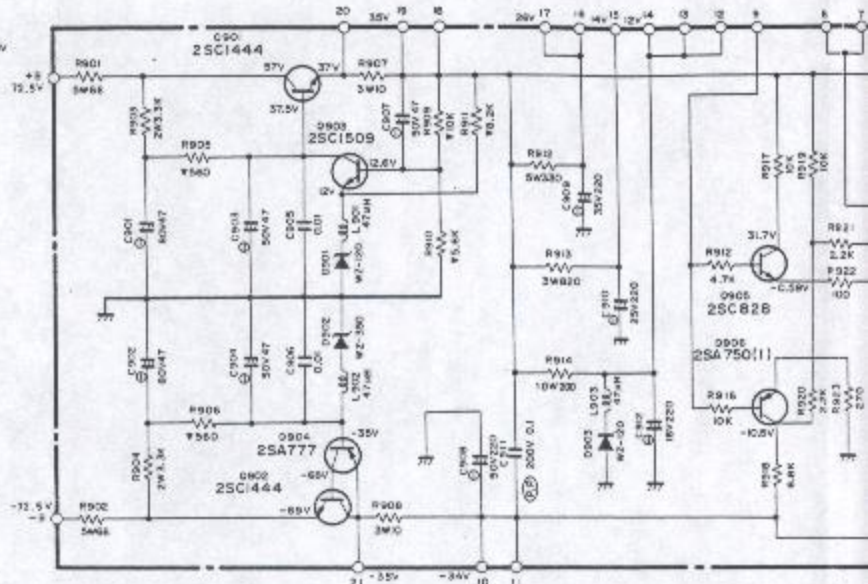
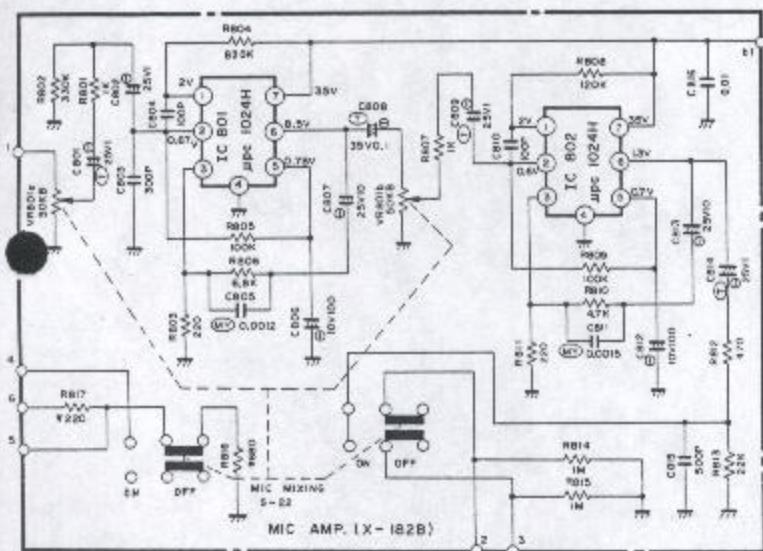

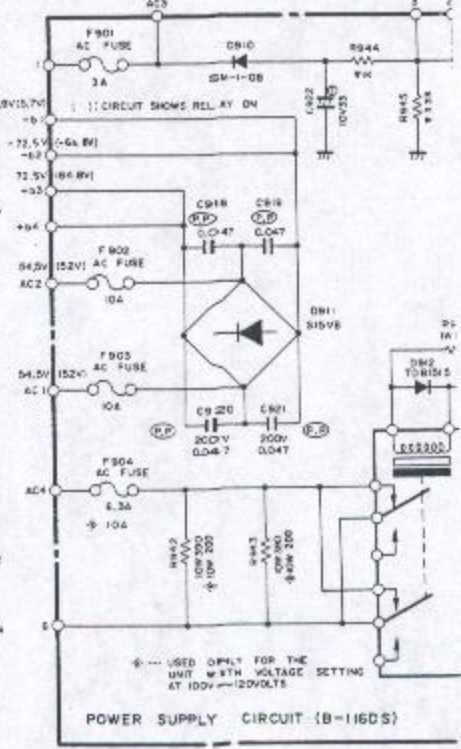
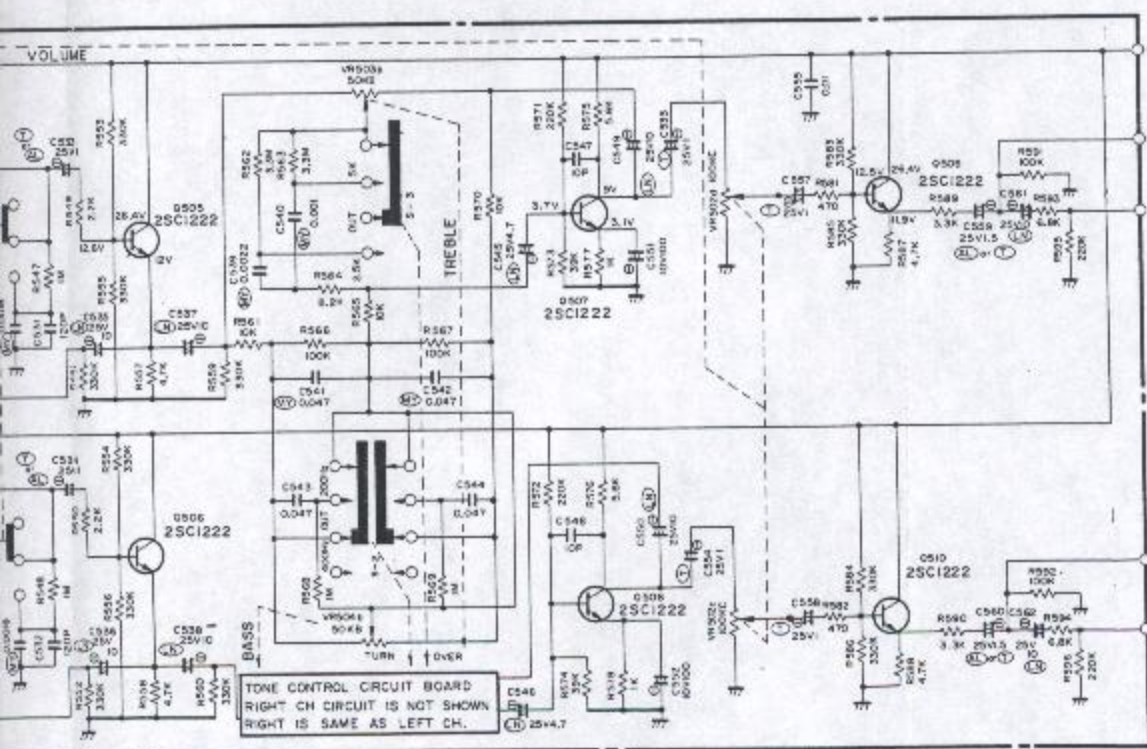
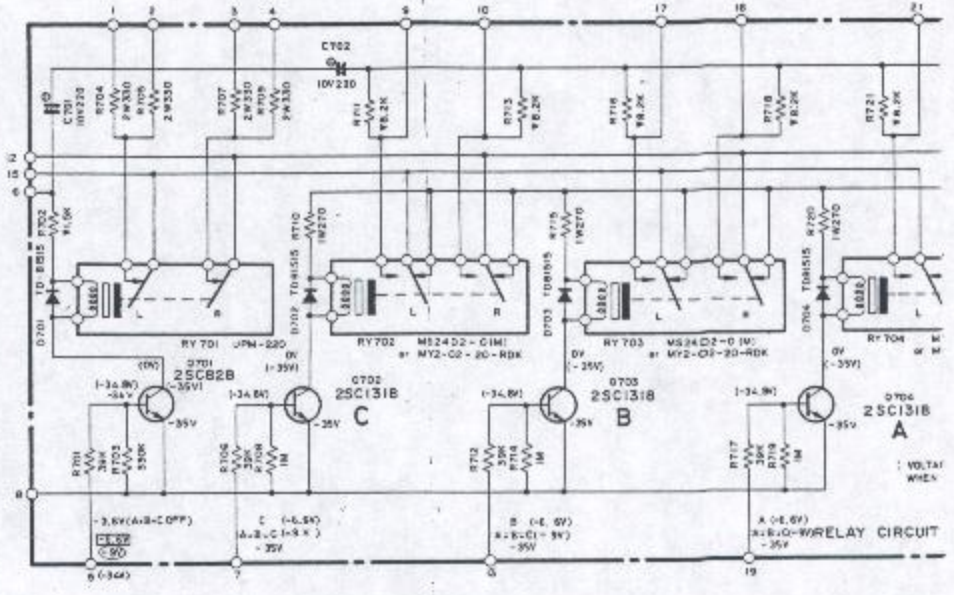
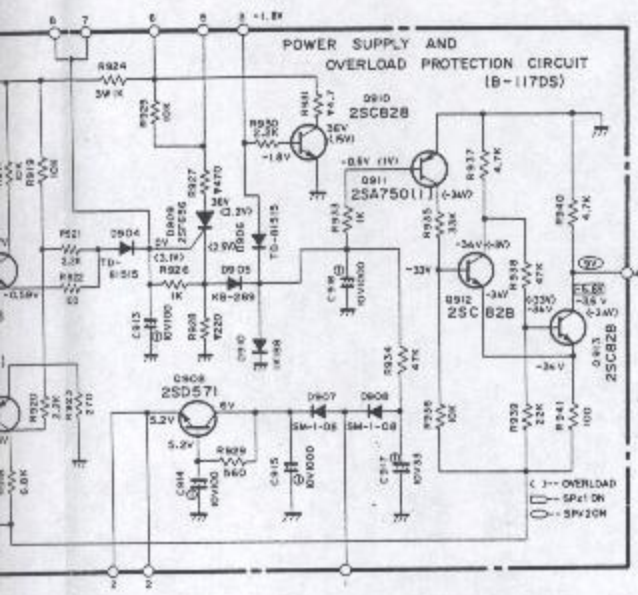

Radio PX 1603

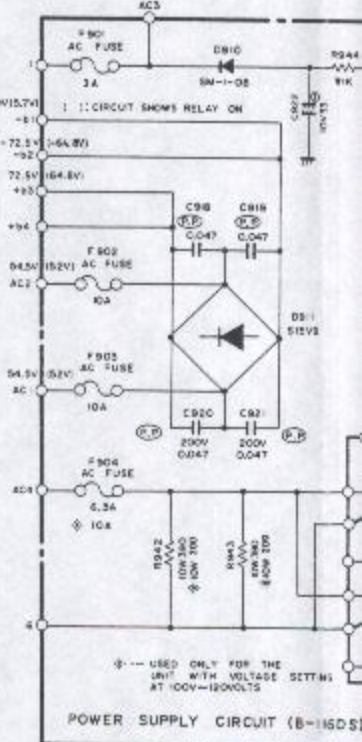
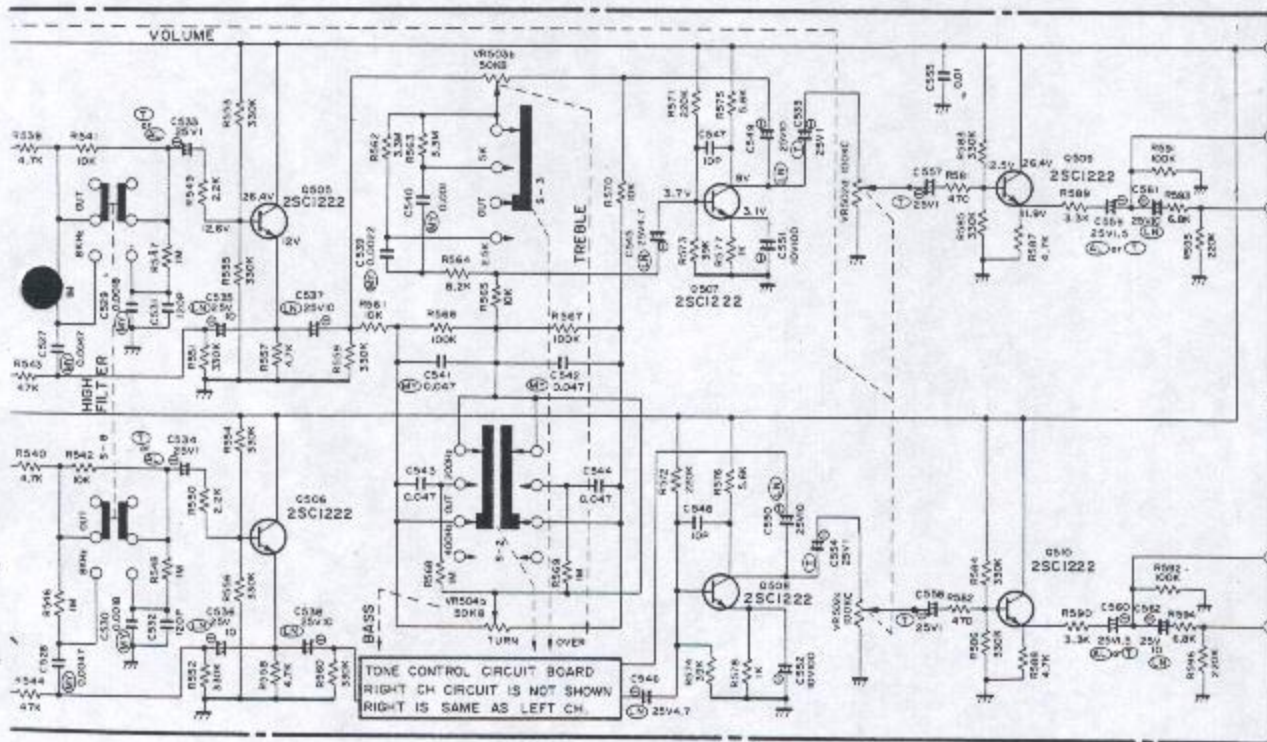
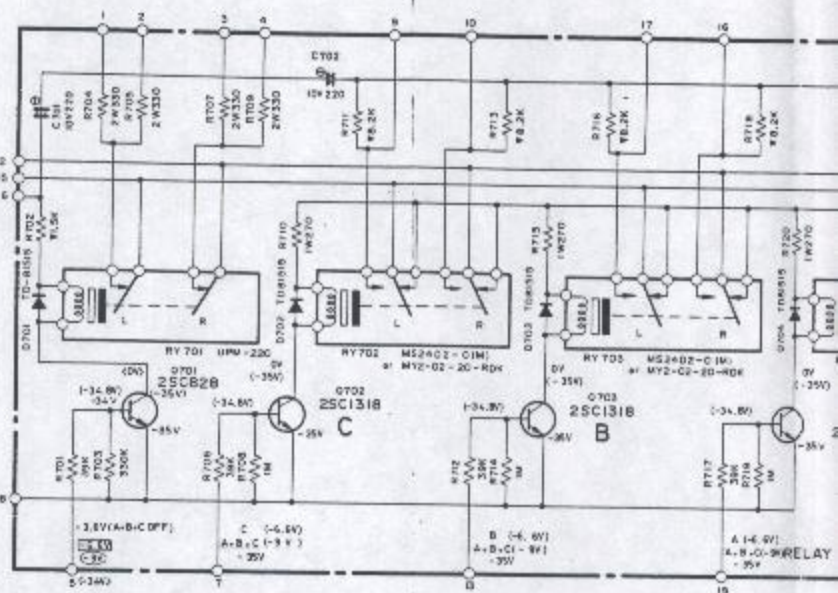
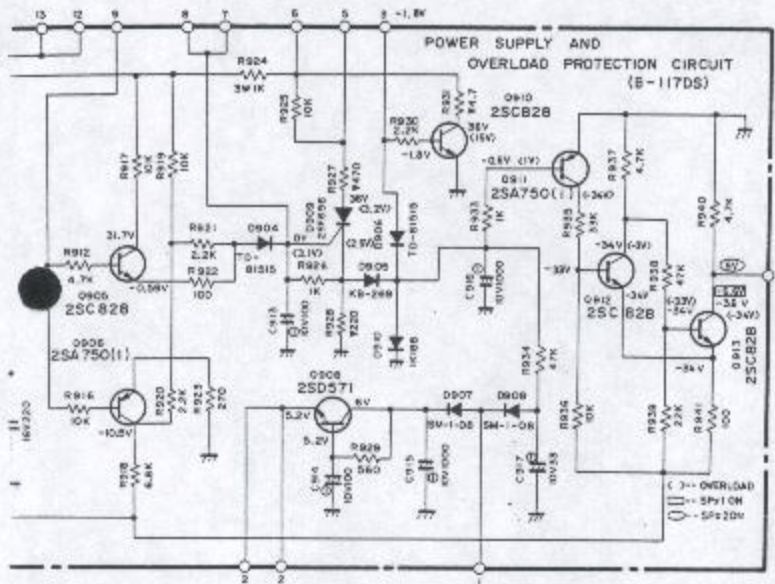

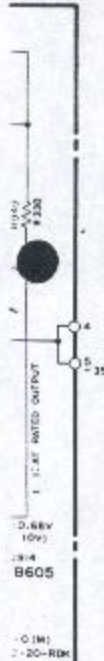
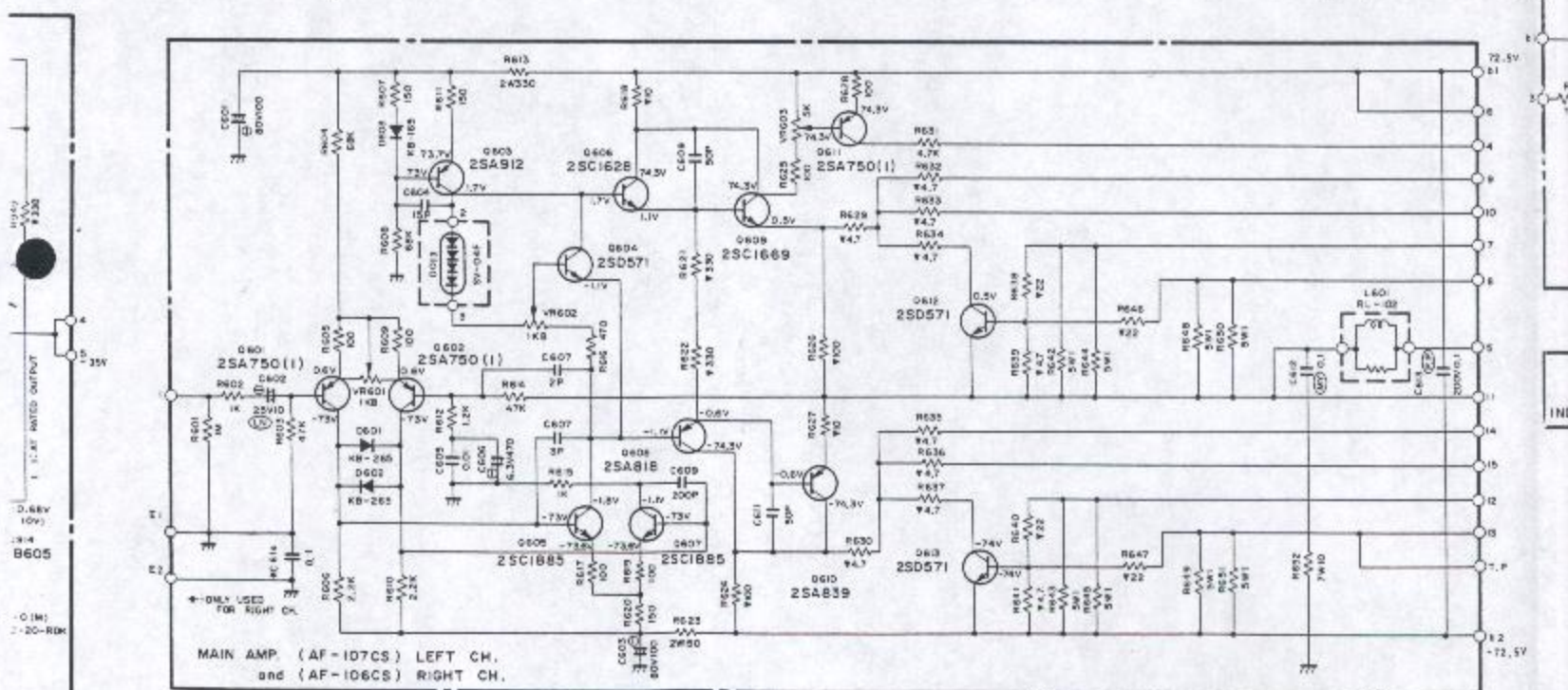
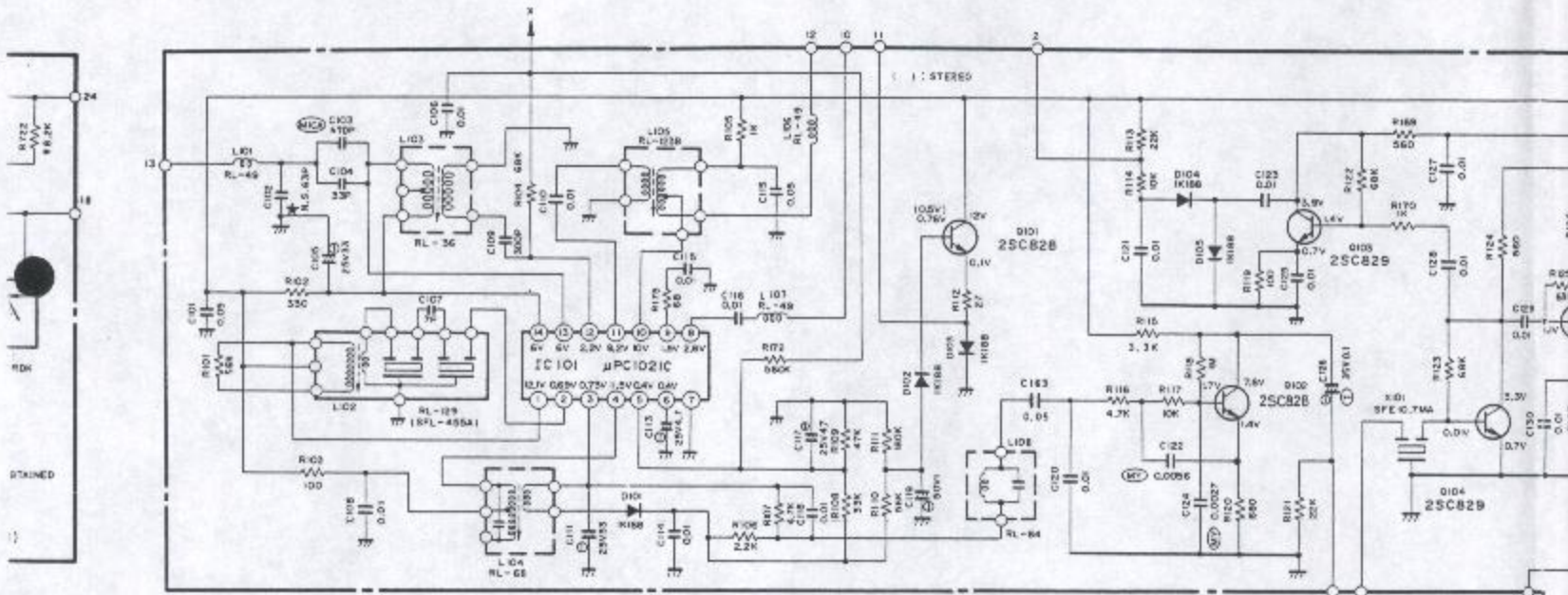

TONE CONTROL AMP CIRCUIT BOARD DIAGRAM
SCHALTBILD DES KLANGREGELVERSTÄRKERS
DIAGRAMME DE PLAQUETTE DE CIRCUIT DE CORRECTEUR DE TONALITE

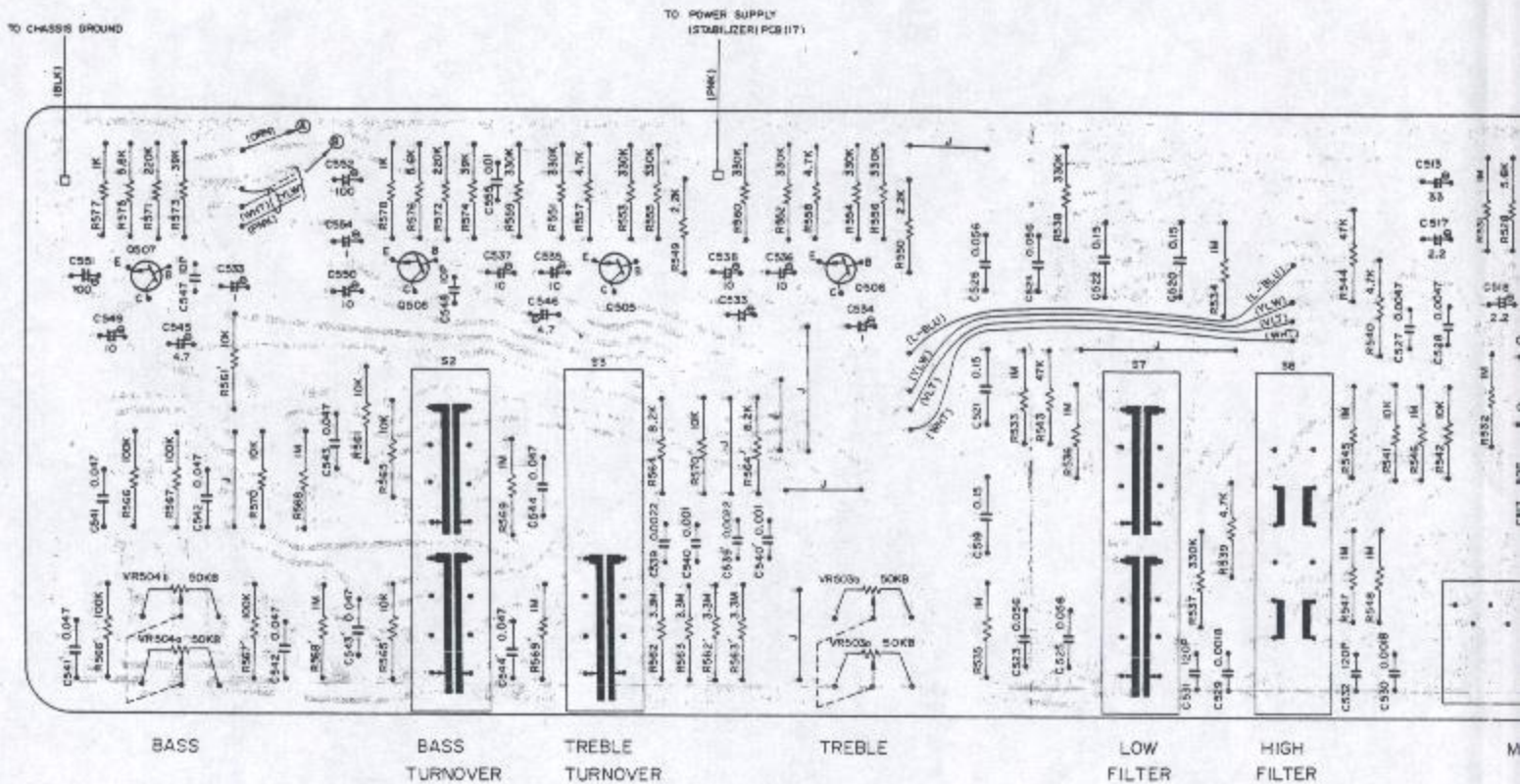

MIC MIXING AMP CIRCUIT BOARD DIAGRAM
SCHALTBILD DES MIKROFONMISCHVERSTÄRKERS
DIAGRAMME DE PLAQUETTE DE CIRCUIT D'AMP. DE MIXAGE DE MIC.

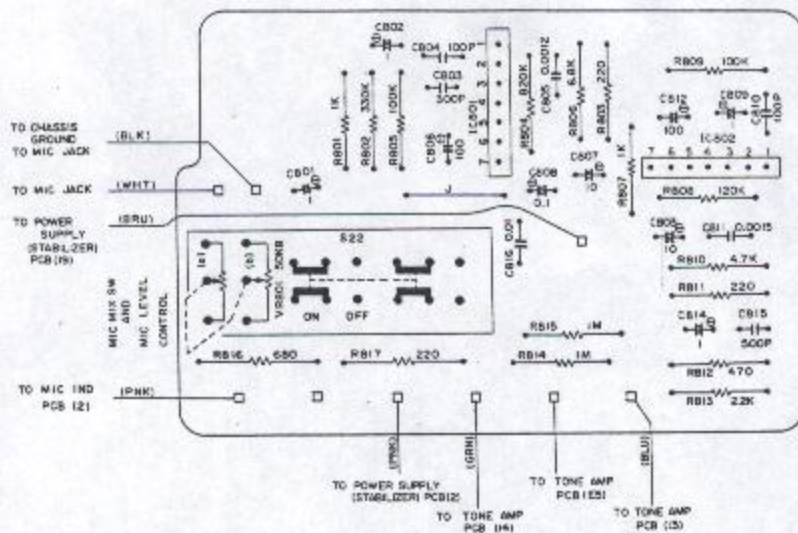

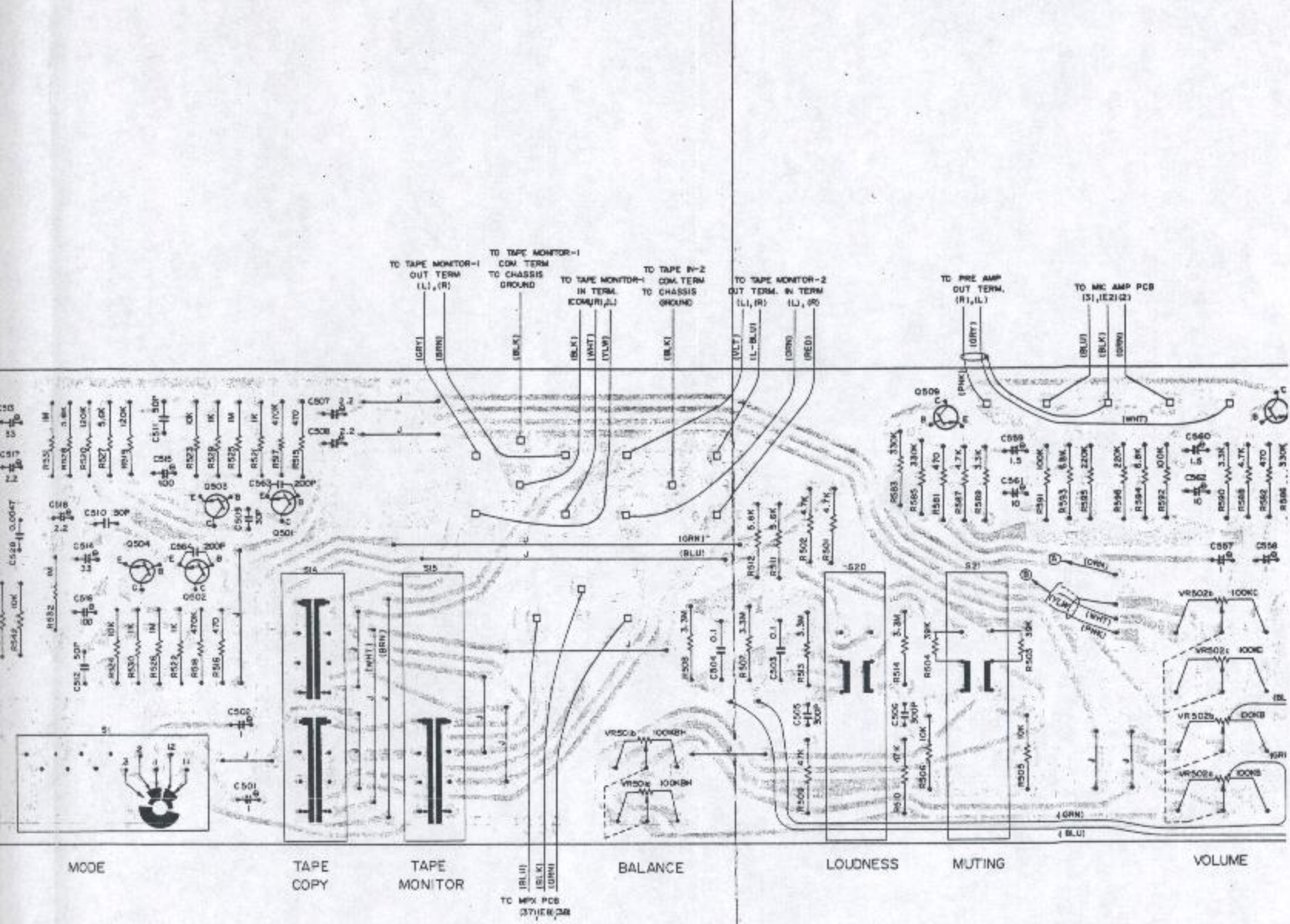

RELAY CIRCUIT BOARD DIAGRAM
RELAIS-SCHALTBILD
DIAGRAMME DE PLAQUETTE DE CIRCUIT A RELAIS

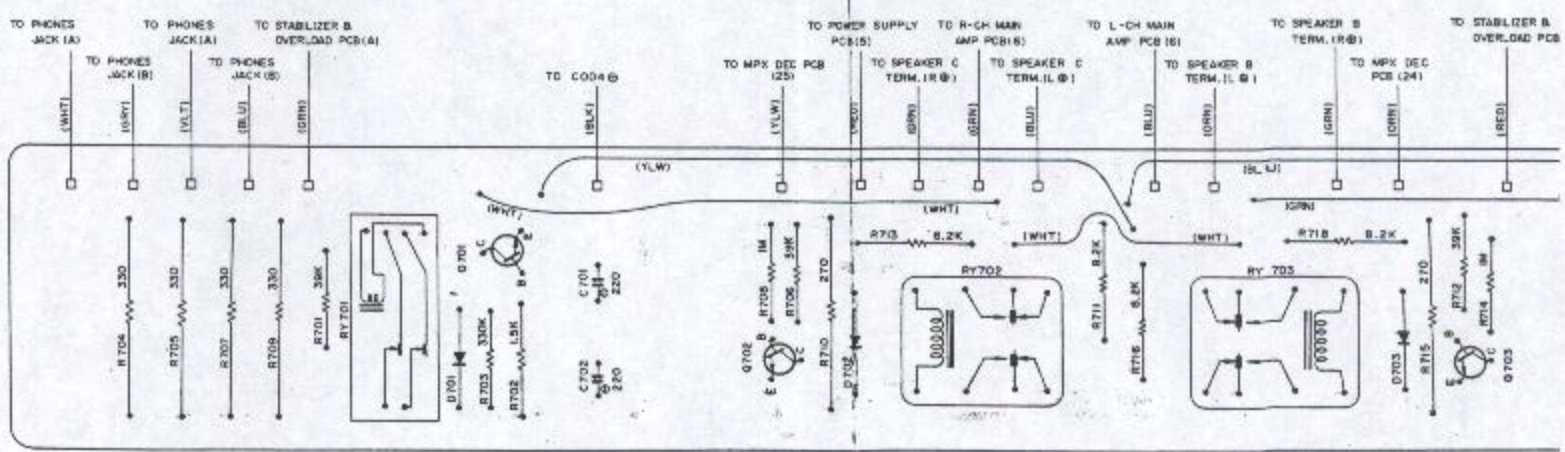

Rotel RX1603

FM MULTIPLEX DECODER AND FUNCTION SWITCH BOARD SCHALTBILD DES UKW-MULTIPLEX DIAGRAMME DE PLAQUETTE DE C DE SELECTEUR DE FONCTION

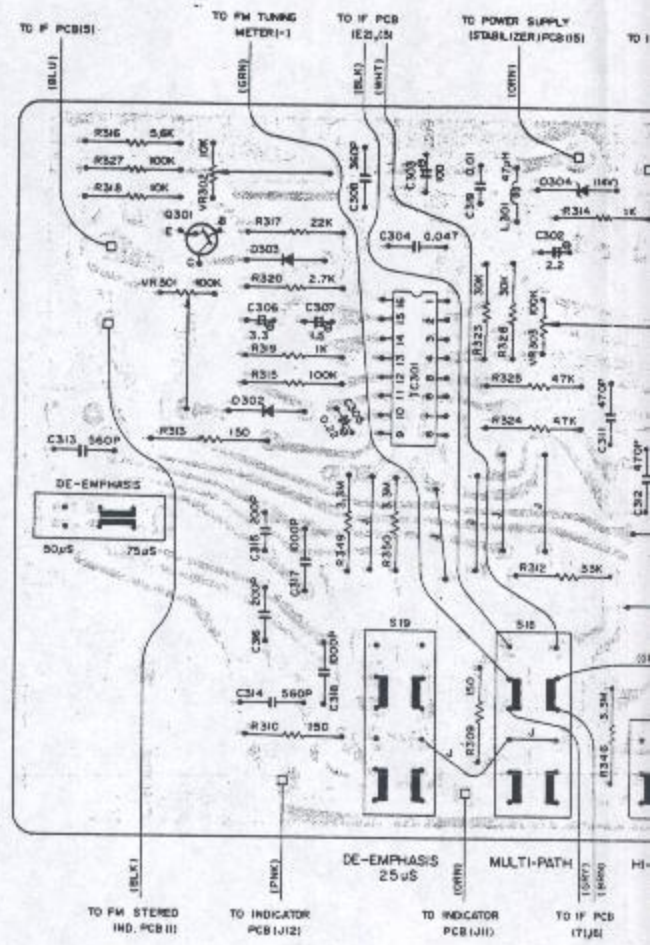
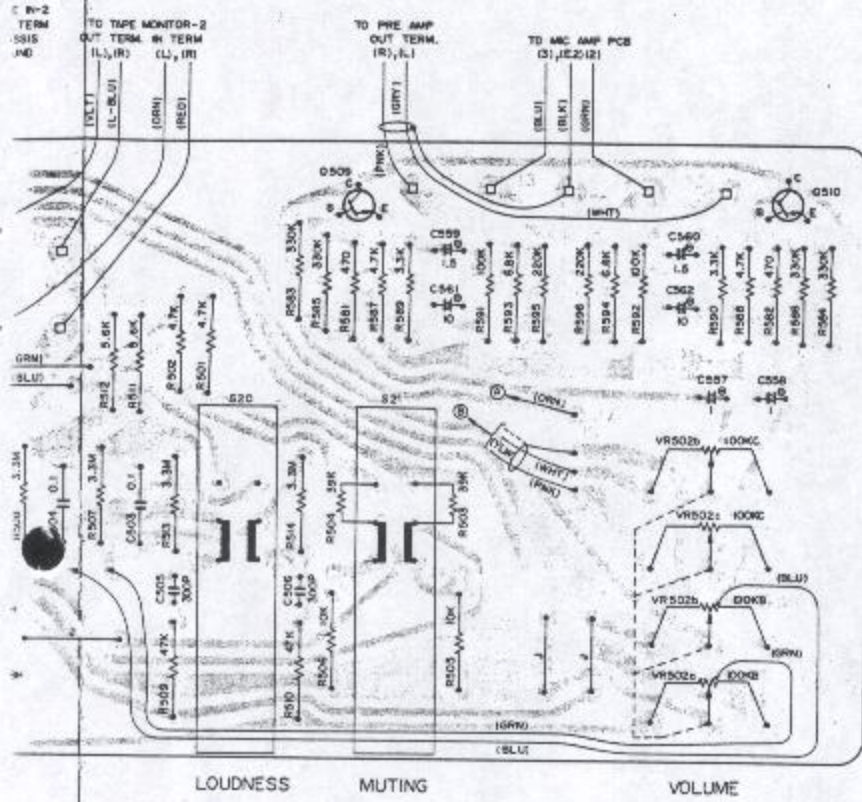

A RELAIS

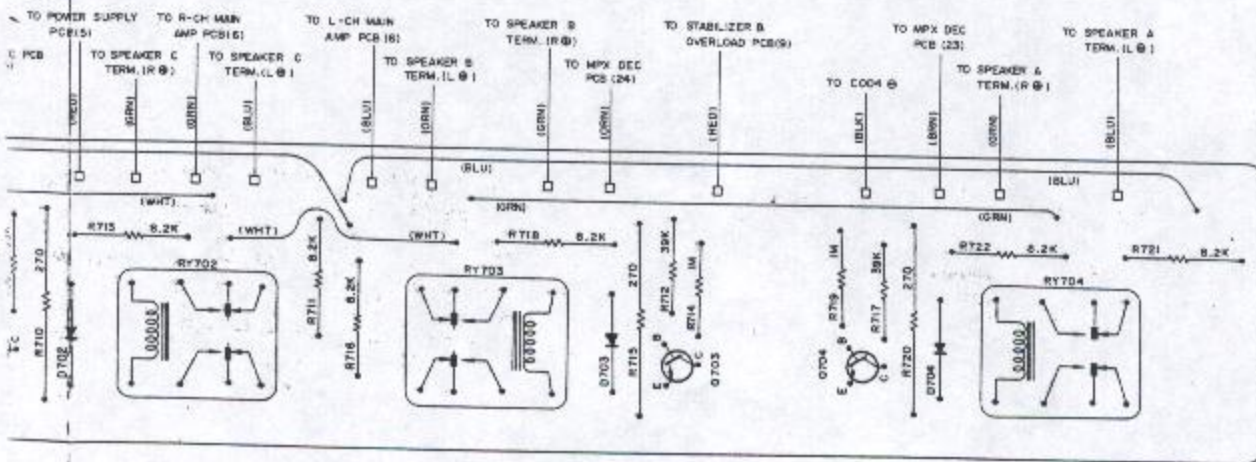

FUNCTION SELECTOR CIRCUIT BOARD DIAGRAM
MULTIPLEX-DECODERS UND FUNKTIONSWÄHLERS
DE CIRCUIT DE DECODEUR MULTIPLEX FM ET
AM

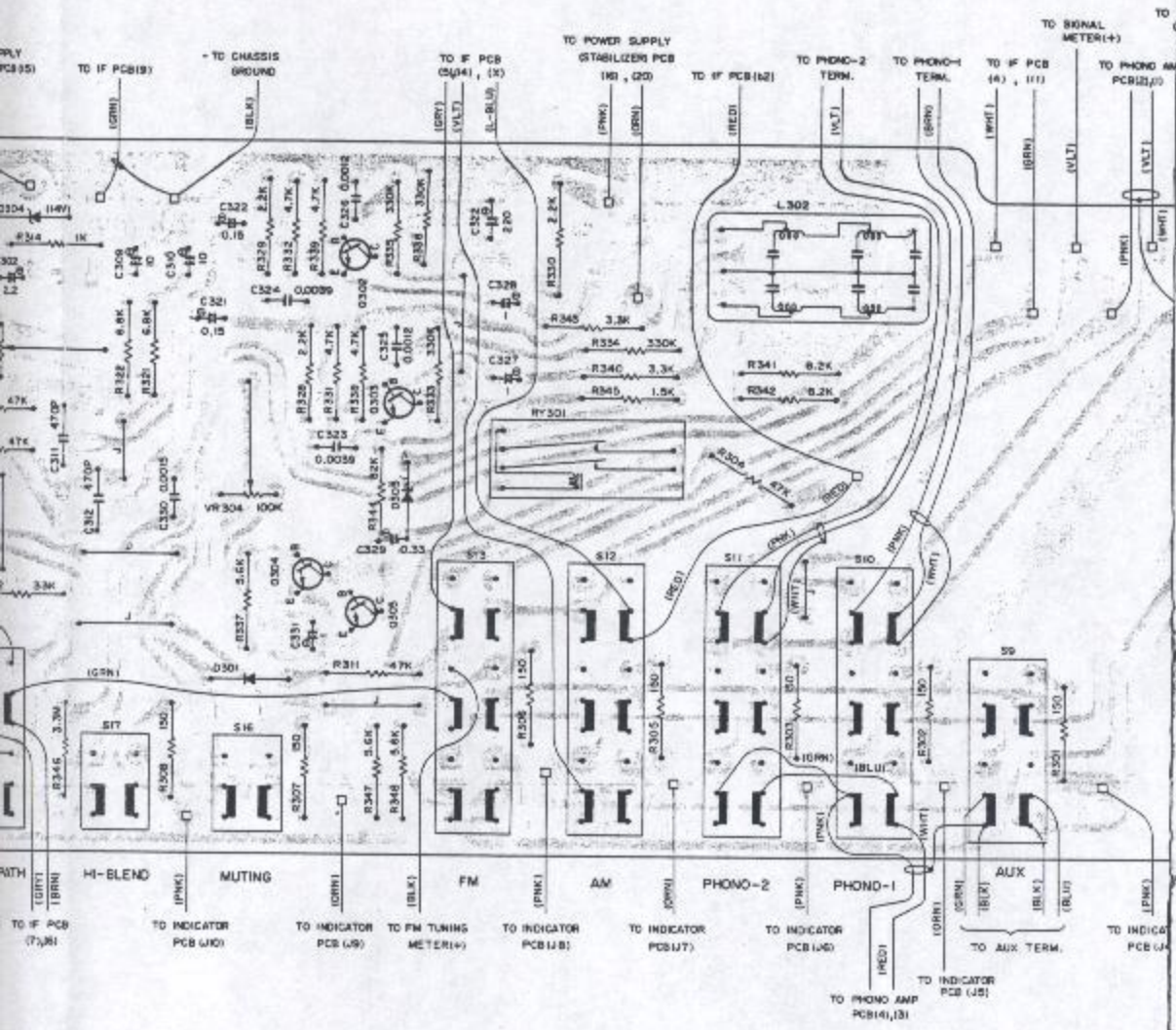

THE ROTEL C
 ROTEL ELEC
 ROTEL OF AN

Rotel RX1603

LTIPLEX DECODER AND FUNCTION SELECTOR CIRCUIT BOARD DIAGRAM

TBILD DES UKW-MULTIPLEX-DECODERS UND FUNKTIONSWÄHLERS

AMME DE PLAQUETTE DE CIRCUIT DE DECODEUR MULTIPLEX FM ET ELECTEUR DE FONCTION

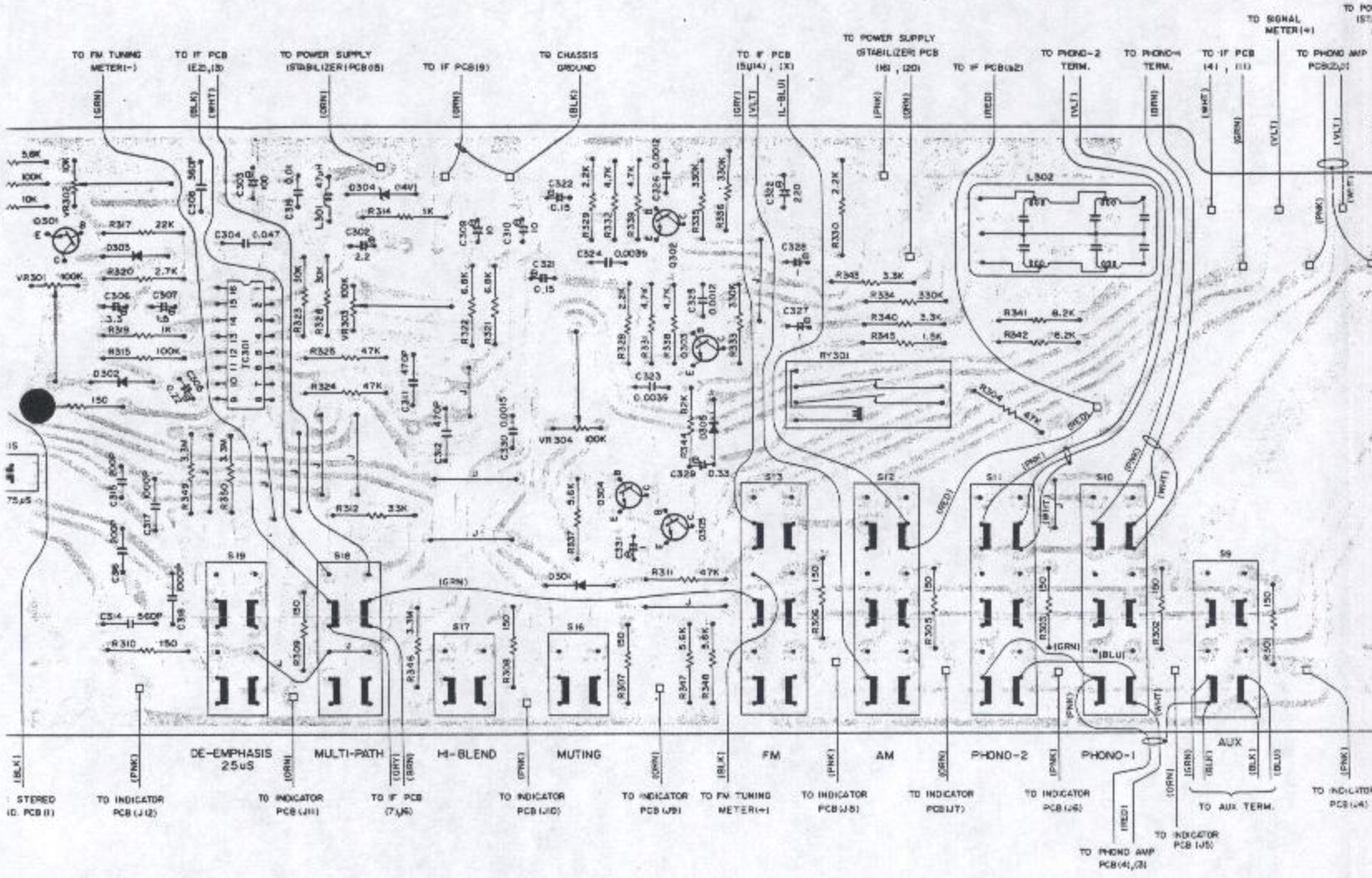

ER A
L 6

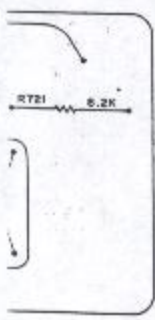

PHONO AMP CIRCUIT BOARD DIAGRAM
 SCHALTBILD DES PHONOVERSTÄRKERS
 DIAGRAMME DE PLAQUETTE DE CIRCUIT
 D'AMP. PHONO

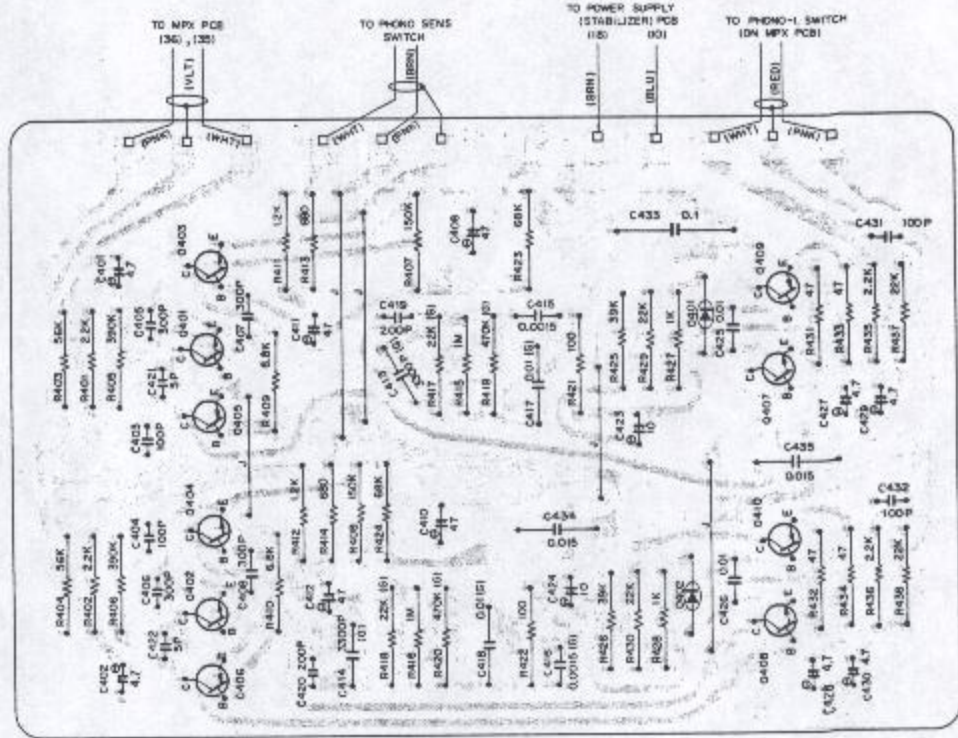
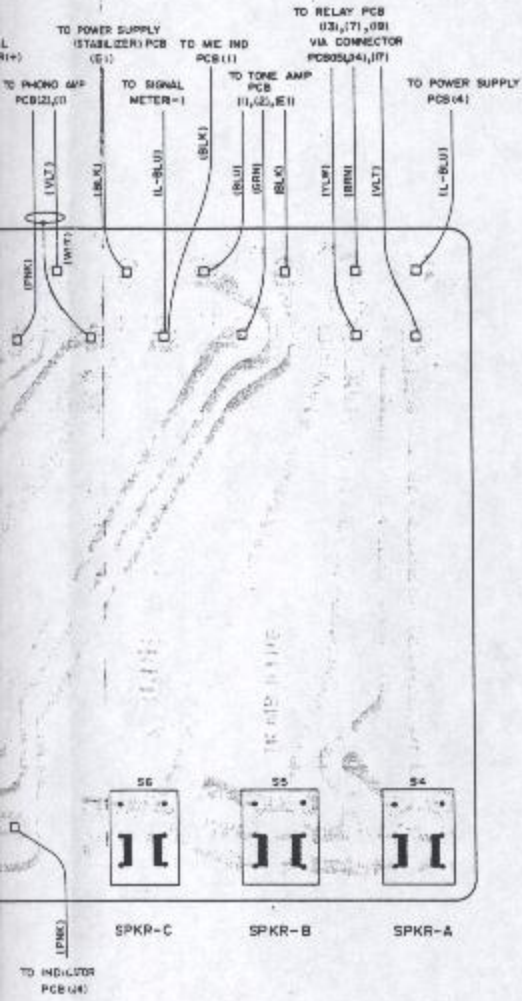

Ricel RX 1603

SCHEMATIC DIAGRAM SCHALTUNGSSCHEMA DIAGRAMME SCHEMATIQUE

AM/FM STEREO RECEIVER RX-1603

This Schematic Diagram is applicable to the units with the following Serial No. and
Serial No. beginning: NA53001
R28056

Dieses Schaltungsschema gilt für Geräte ab folgenden Seriennummern:
Seriennummer, Anfang: NA53001
R28056

Ce diagramme schématique est applicable aux unités ayant le No. de série suivant.
Numéro de série commençant par: NA53001
R28056

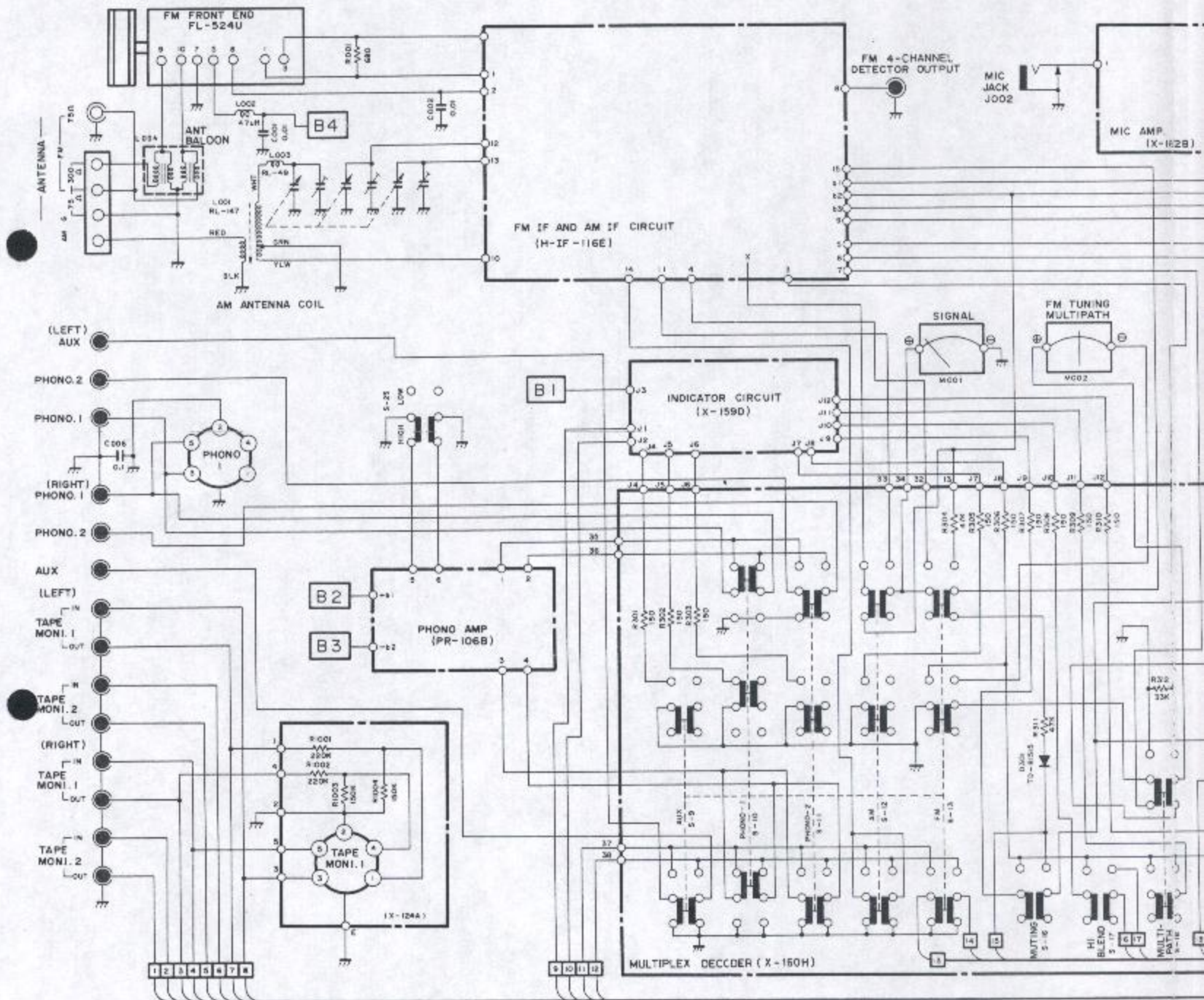

ROTEL®

Dahl Elektronik GmbH, Postfach 70 16 29, D-2000 Hamburg 70

No. and onward.

variant.

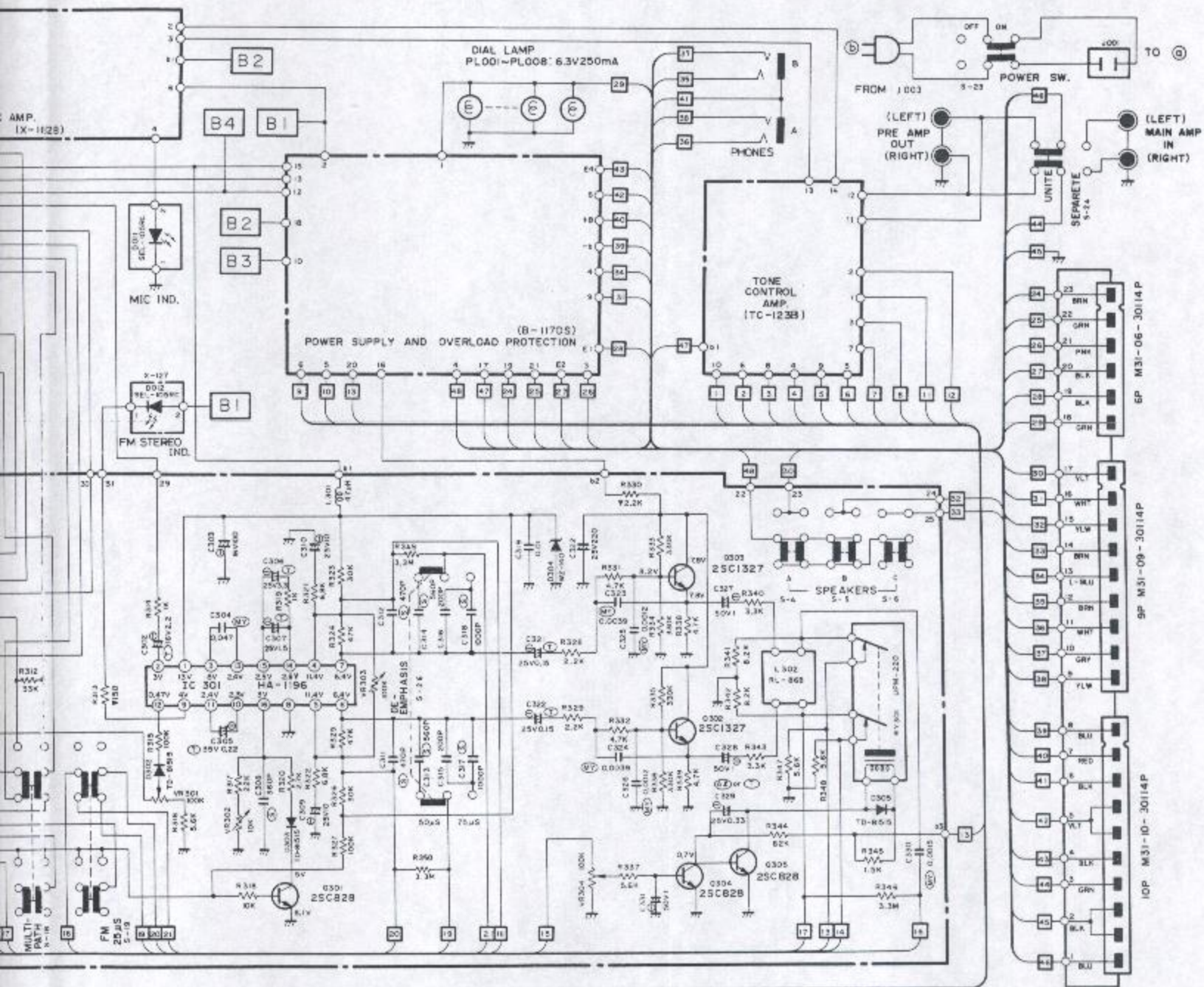

ROTEL RX-1603 TUNER / PREAMP CIRCUIT DIAGRAM.

SCHEMATIC DIAGRAM SCHALTUNGSSHEMA DIAGRAMME SCHEMATIQUE

This Schematic Diagram is applicable to the units with the following Serial No. beginning: NA53001
R28056

Dieses Schaltungsschema gilt für Geräte ab folgenden Seriennummern
Seriennummer, Anfang: NA53001
R28056

Ce diagramme schématique est applicable aux unités ayant le No. de série
Numéro de série commençant par: NA53001
R28056

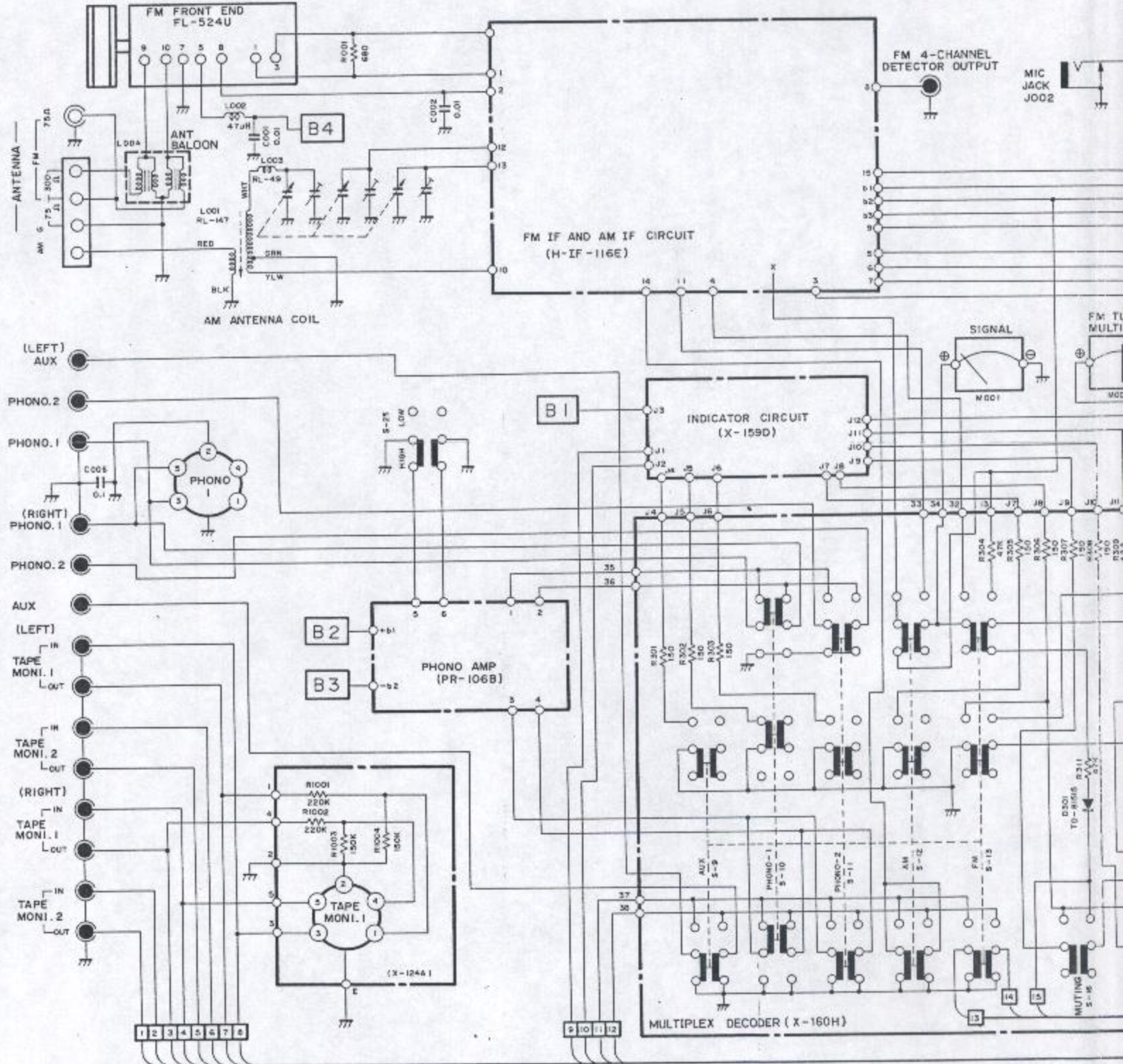

Following Serial No. and onward.

nummern:

No. de série suivant.

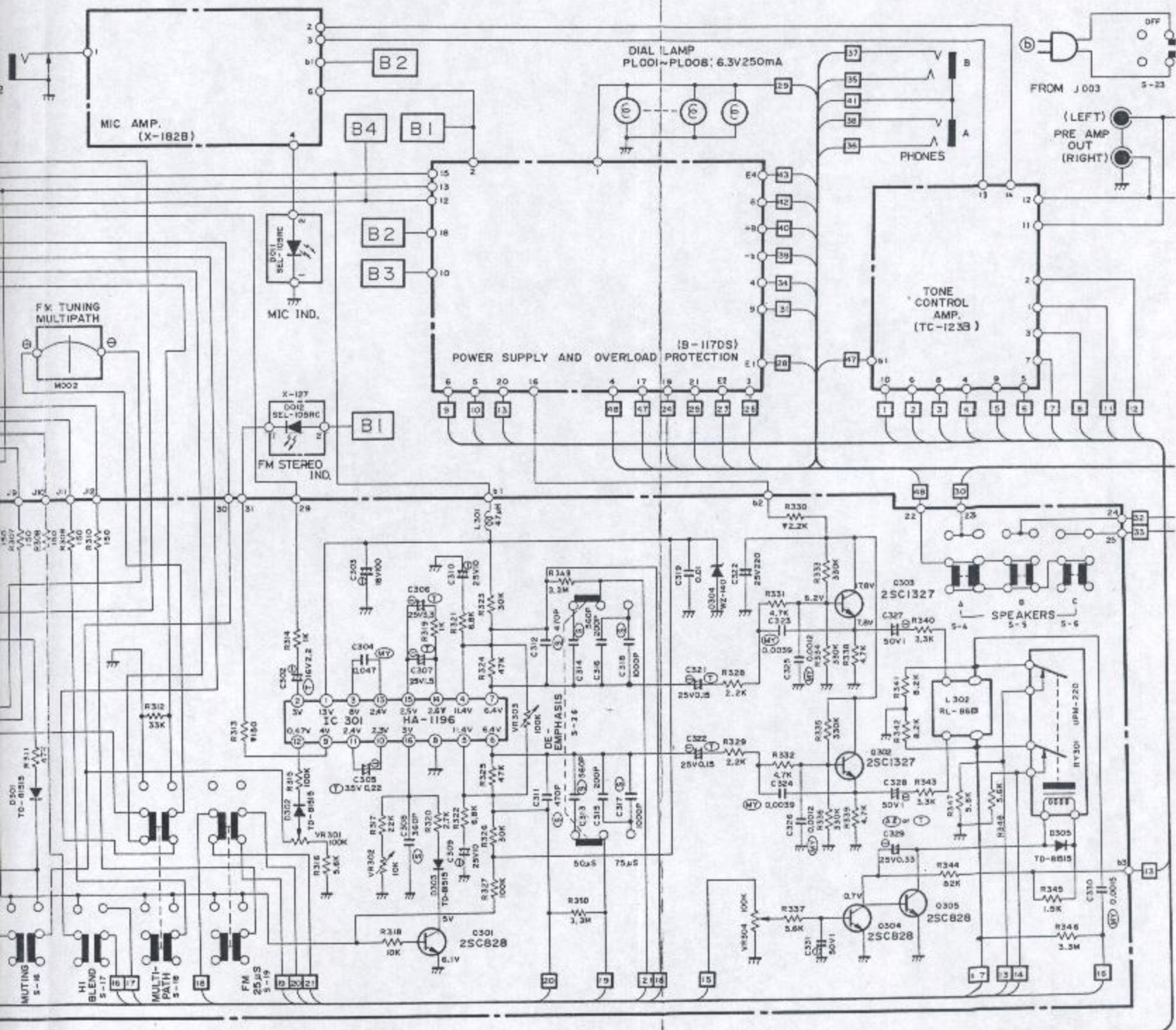

ROTEL RX-1603 TUNER / PREAMP CIF

ROTEL RX-1603 MAIN AMP.
CIRCUIT DIAGRAM

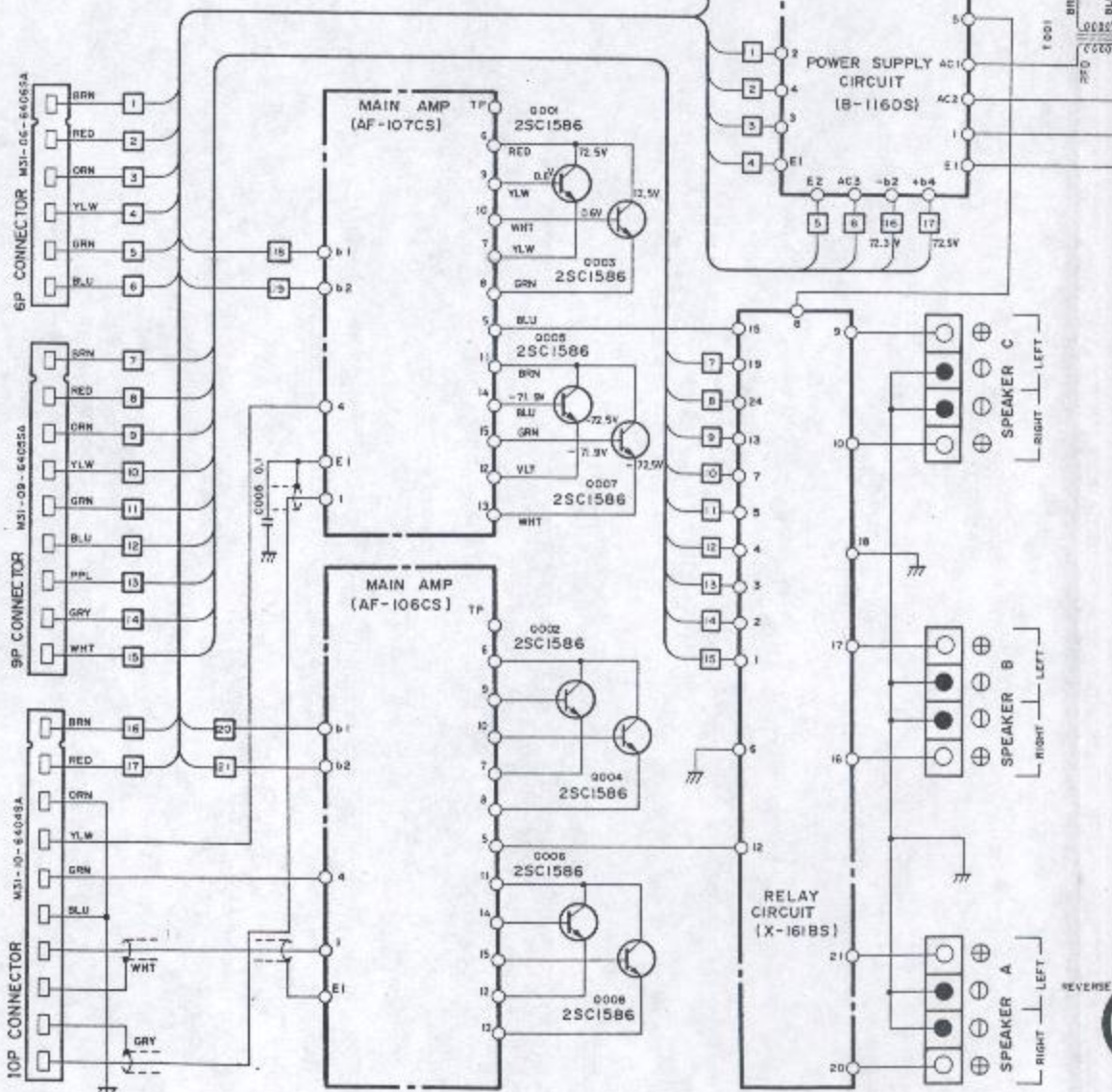
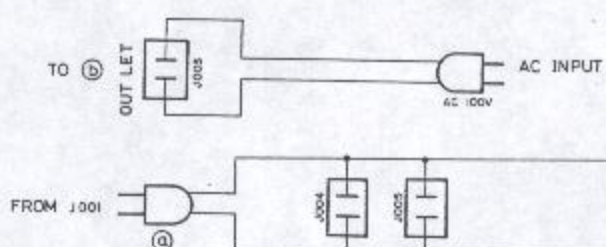
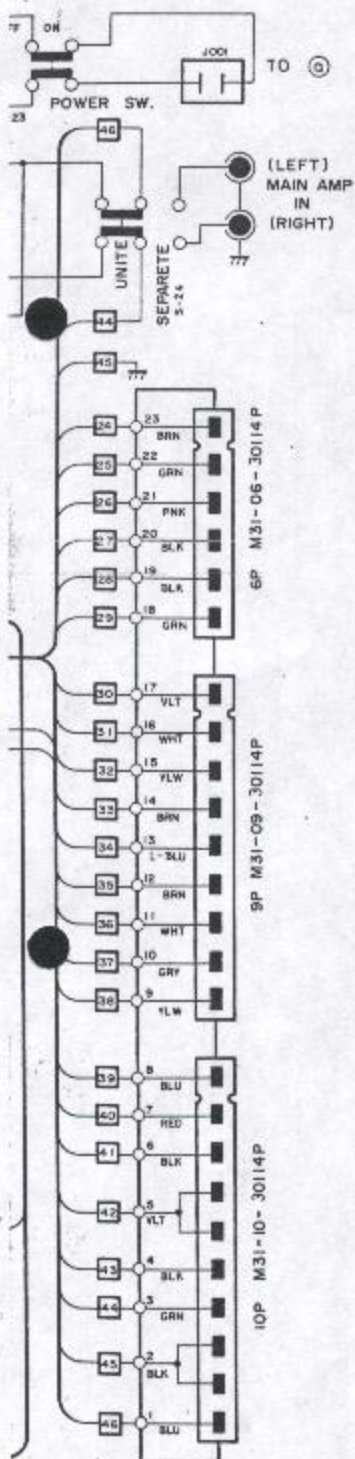

CIRCUIT DIAGRAM.

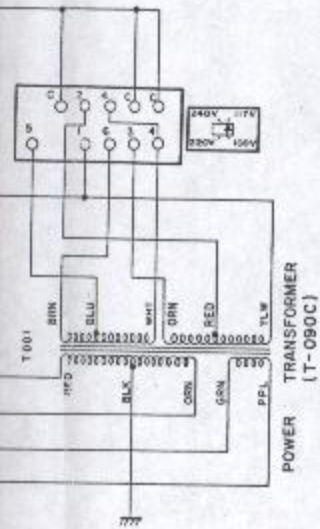

POWER TRANSFORMER (T-090C)

- 25C1400
- 25C1222
- 25C828
- 25C829
- 25C1318
- 25A750 (I)
- 25A912
- 25A777

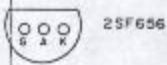

BOTTOM VIEW

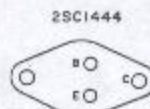
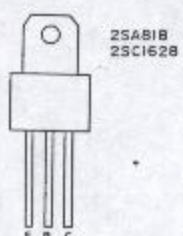
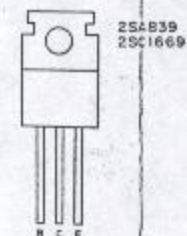
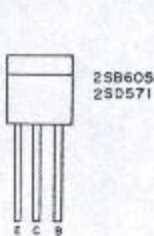

SIDE VIEW

BOTTOM VIEW

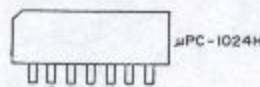
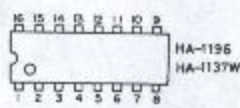
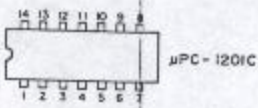

TOP VIEW

SIDE VIEW

RESISTORS

- 5% --- TOLERANCE UNLESS OTHERWISE NOTED.
- K --- KILO OHM.
- M --- MEGA OHM.
- ∇ --- COMPOSITION RESISTORS 1/2 WATT.
- NONMARK --- LOW NOISE TYPE CARBON RESISTORS 1/4 WATT.

CAPACITORS

- MY --- MYLAR FILM CAPACITORS.
- AL --- SINTERED ALUMINUM SOLID ELECTROLYTIC CAPACITORS (ALSIODN).
- S --- POLYSTYRENE FILM CAPACITORS.
- ∅ --- TANTALUM CAPACITORS.
- N --- LOW NOISE TYPE CAPACITORS.
- E --- ELECTROLYTIC CAPACITORS.
- * --- TEMPERATURE COEFFICIENT CAPACITORS.
- NONMARK --- CERAMIC CAPACITORS.
- UNLESS OTHERWISE NOTED IN SCHEMATIC ALL CAPACITANCE VALUES ARE EXPRESSED IN MFD.
- VOLTAGE READING WITH VTVM FROM THE POINT SHOWN TO THE CHASSIS GROUND (LINE VOLTAGE 120VOLT).
- VOLTAGE READING MAY VARY ±20%.
- Ⓟ --- POLYPROPYLENE FILM CAPACITORS.

ITEM	SCHEMATIC LOCATION LAST	
FM IF AND AM IF CIRCUIT	R177	C16B
MULTIPLEX DECODER	R350	C33I
PHONO AMP.	R438	C435
tone CONTROL AMP.	R596	C564
MAIN AMP.	R652	C614
RELAY CIRCUIT	R722	C702
MIC AMP.	R817	C816
POWER SUPPLY CIRCUIT	R949	C922
CHASSIS	R001	C006

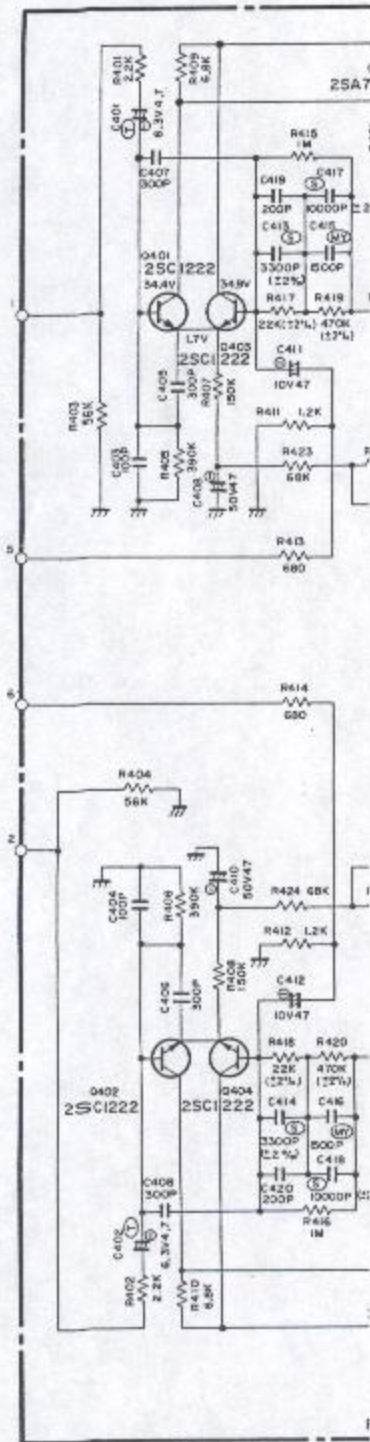

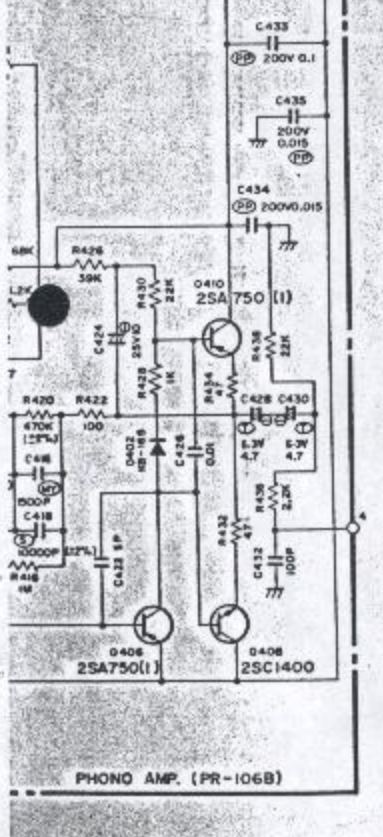
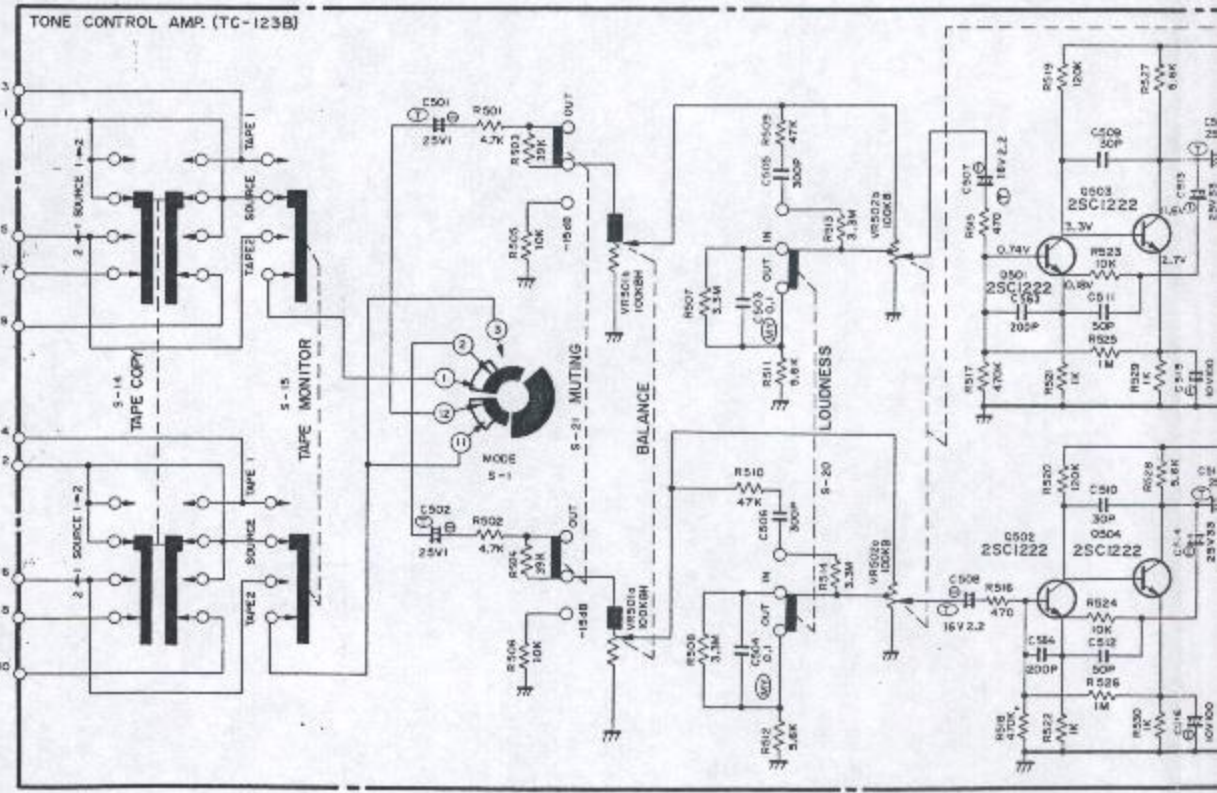
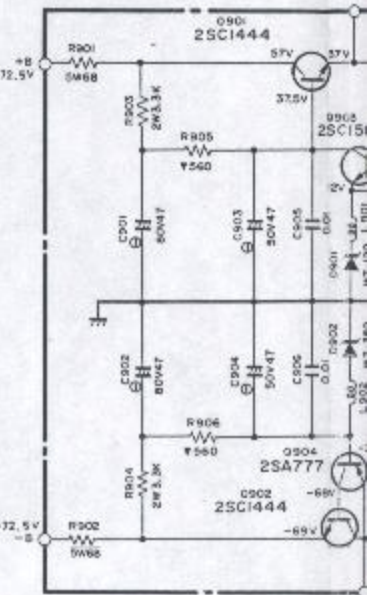
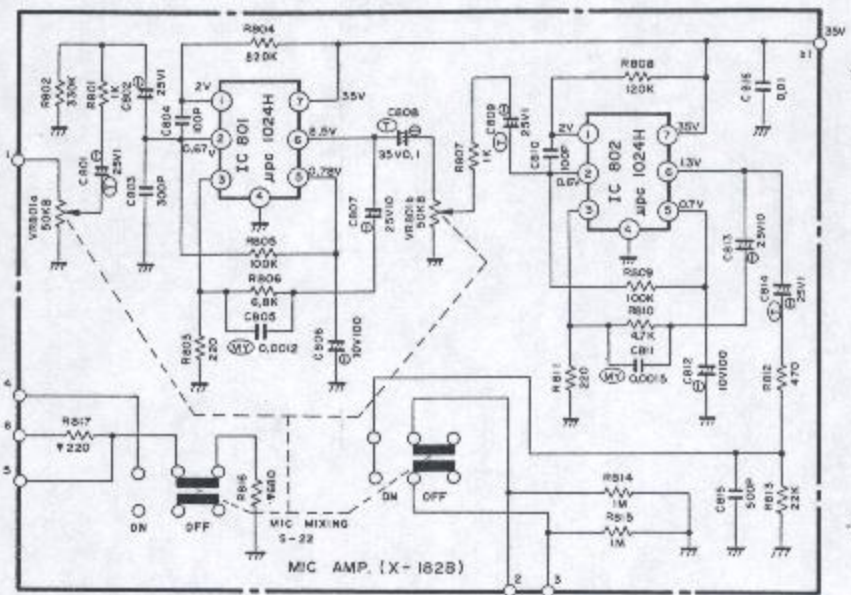
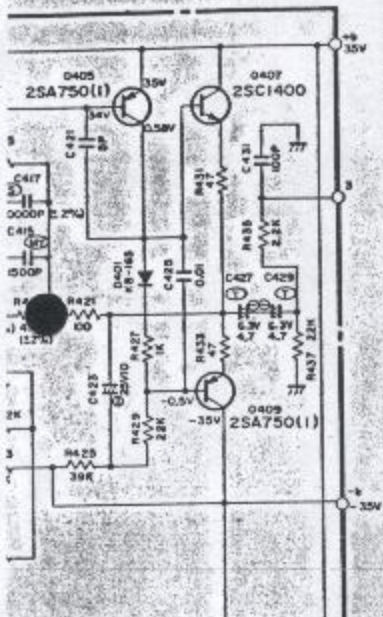

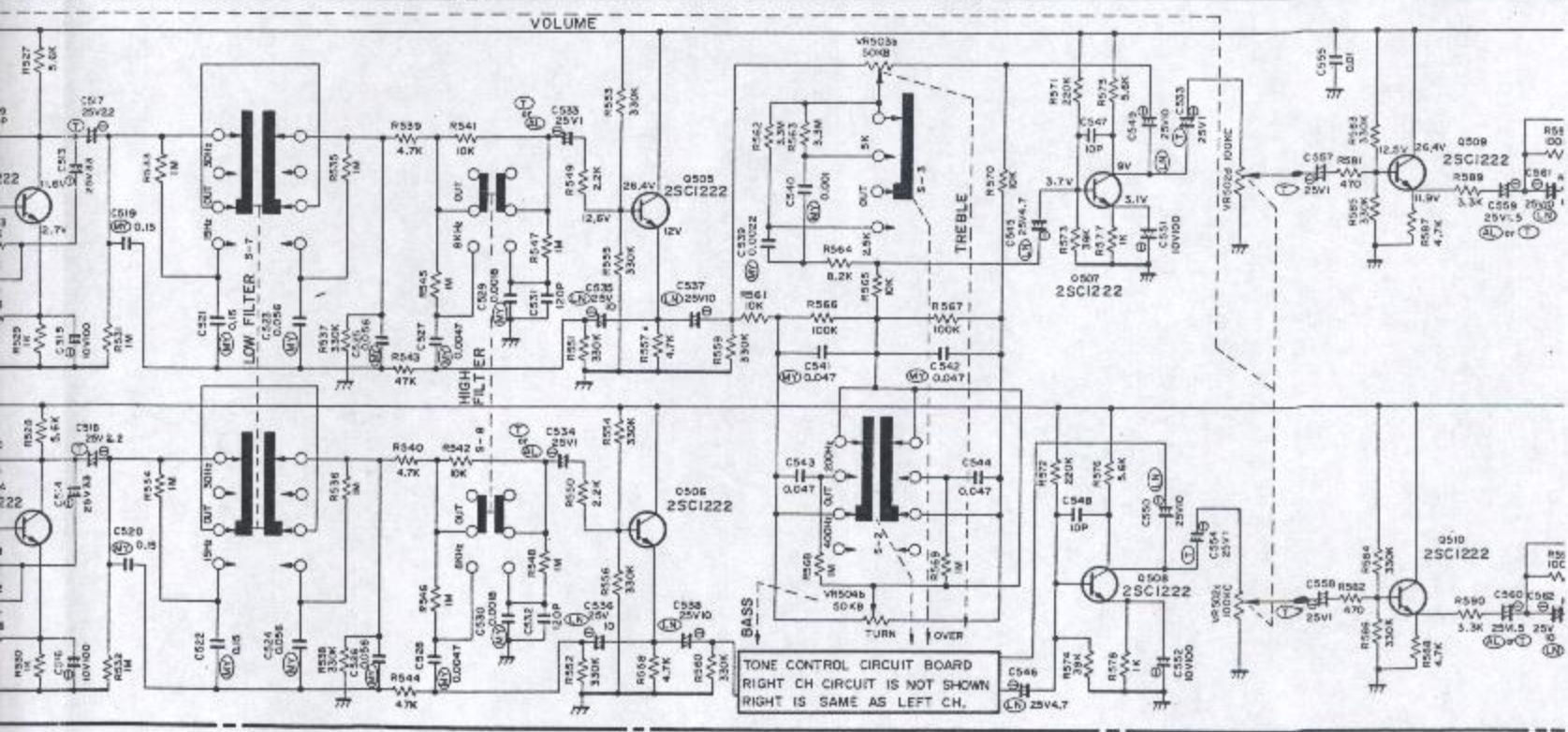
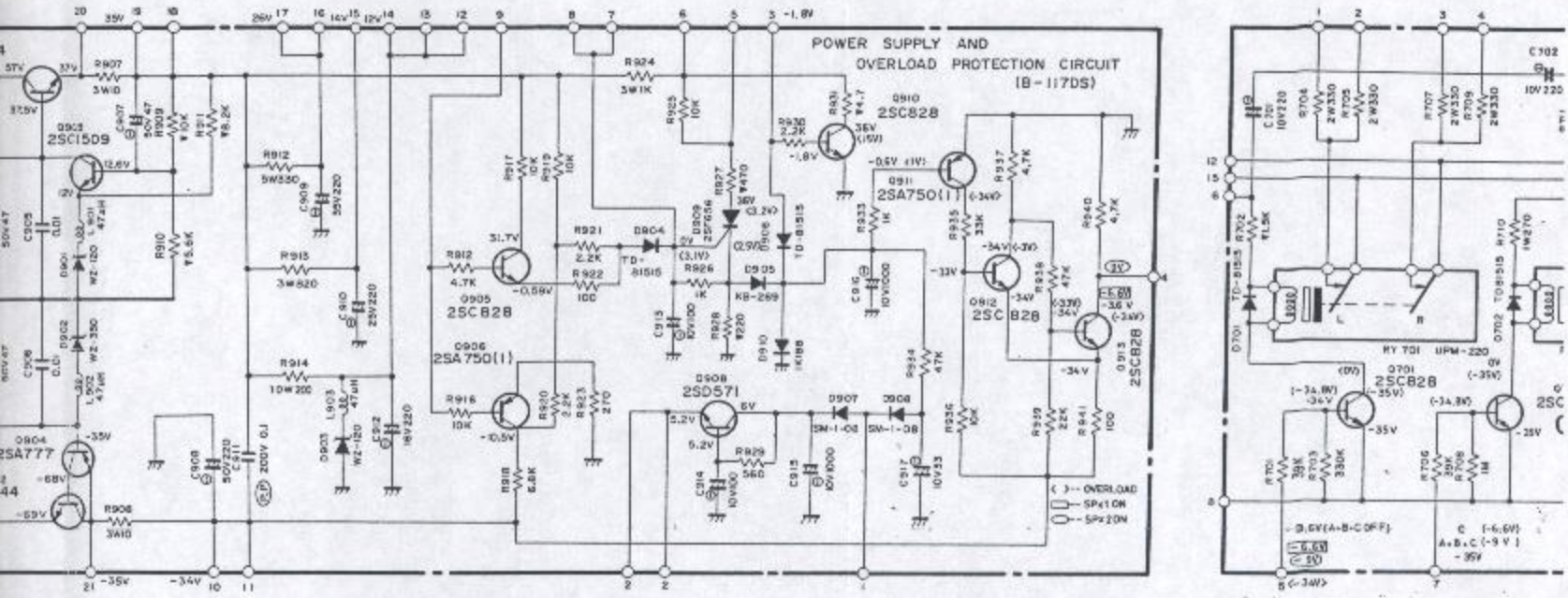

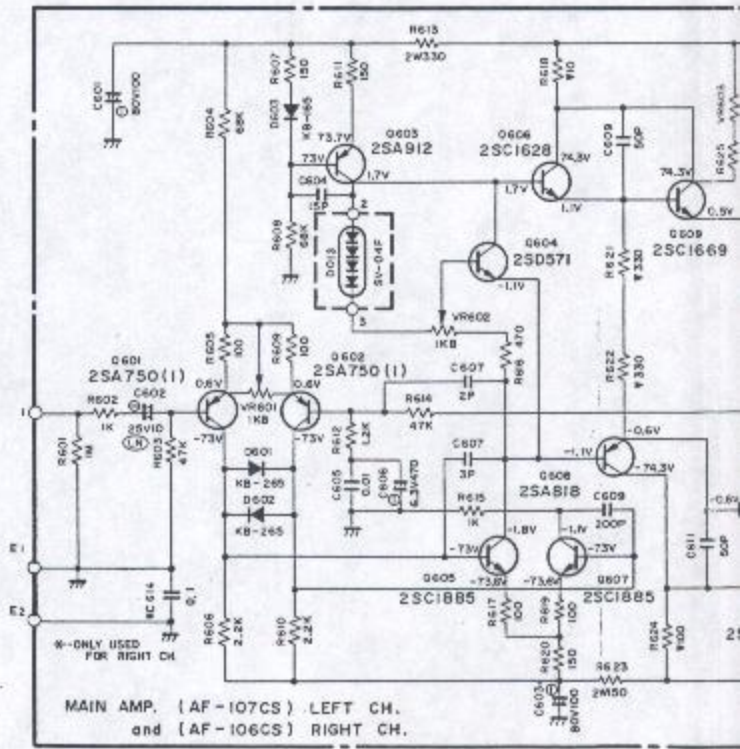
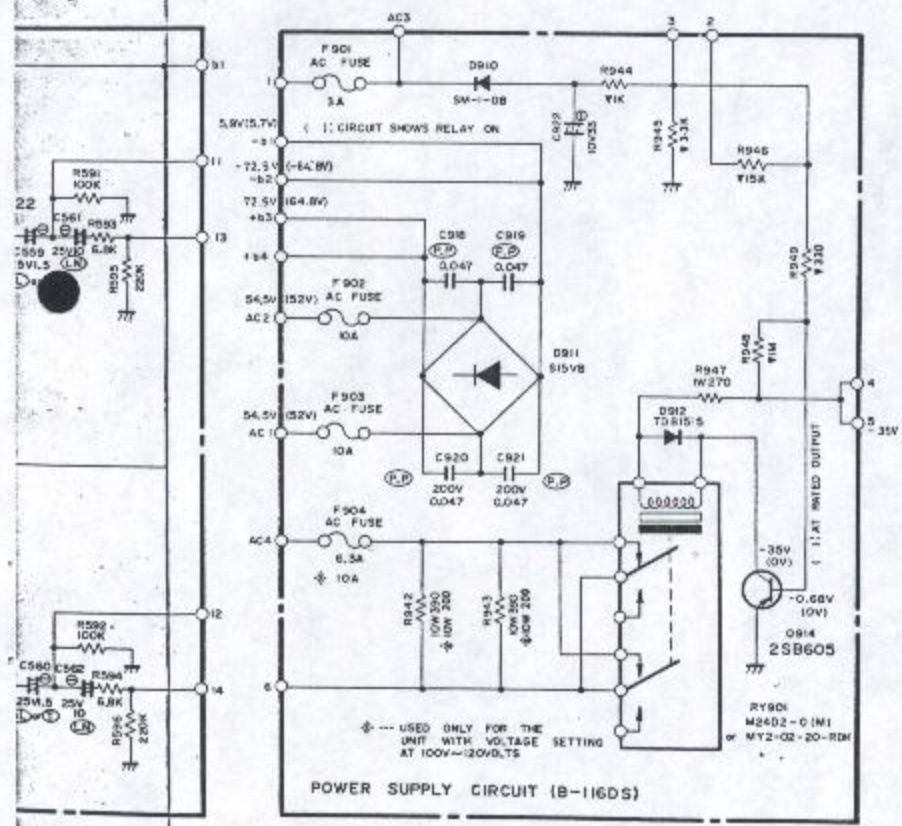
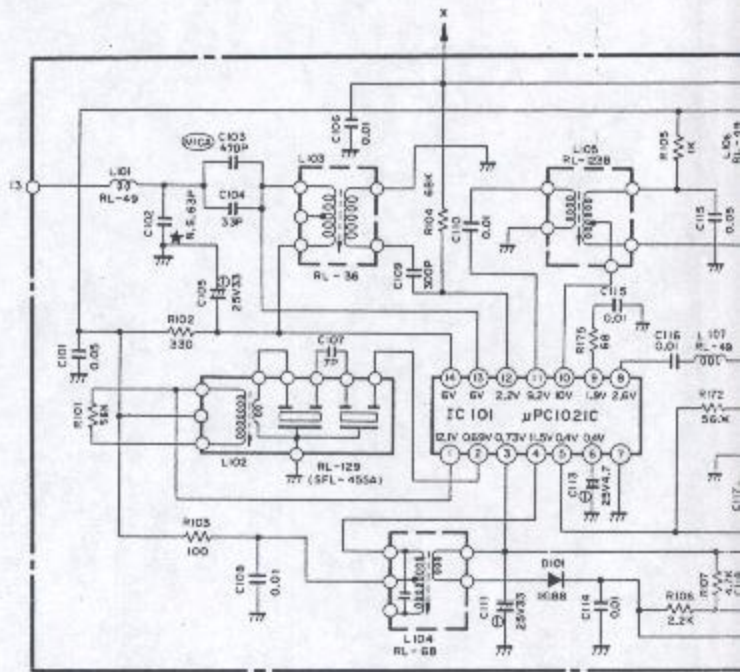
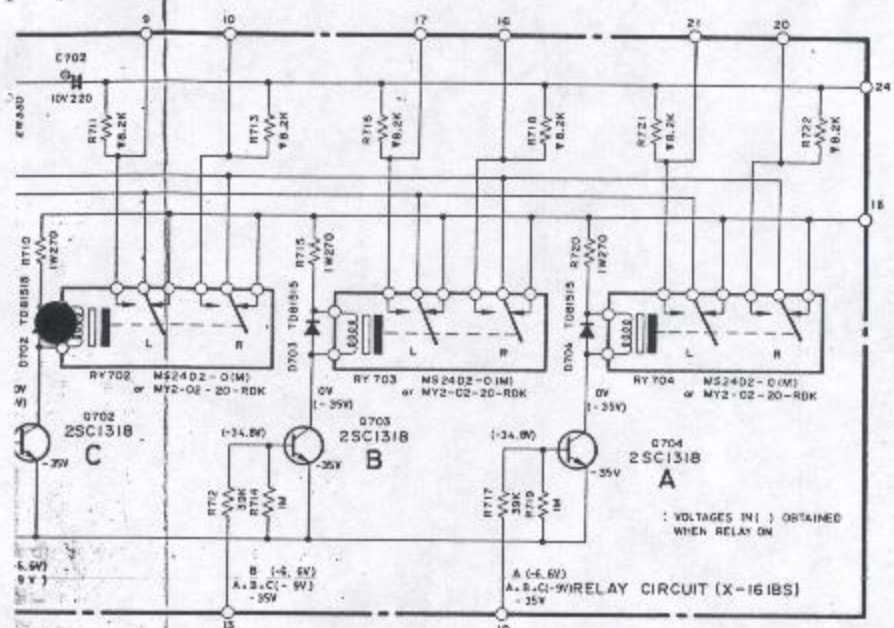

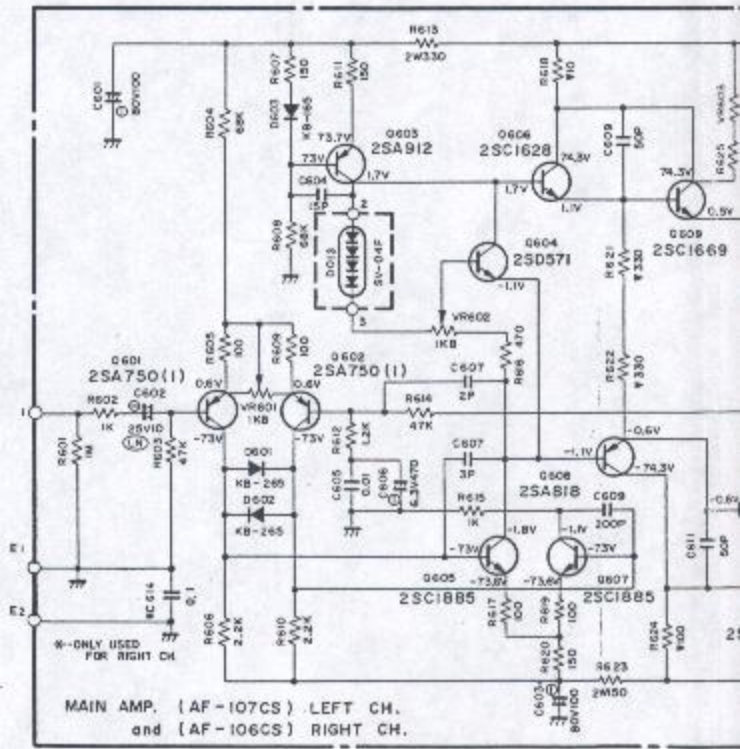
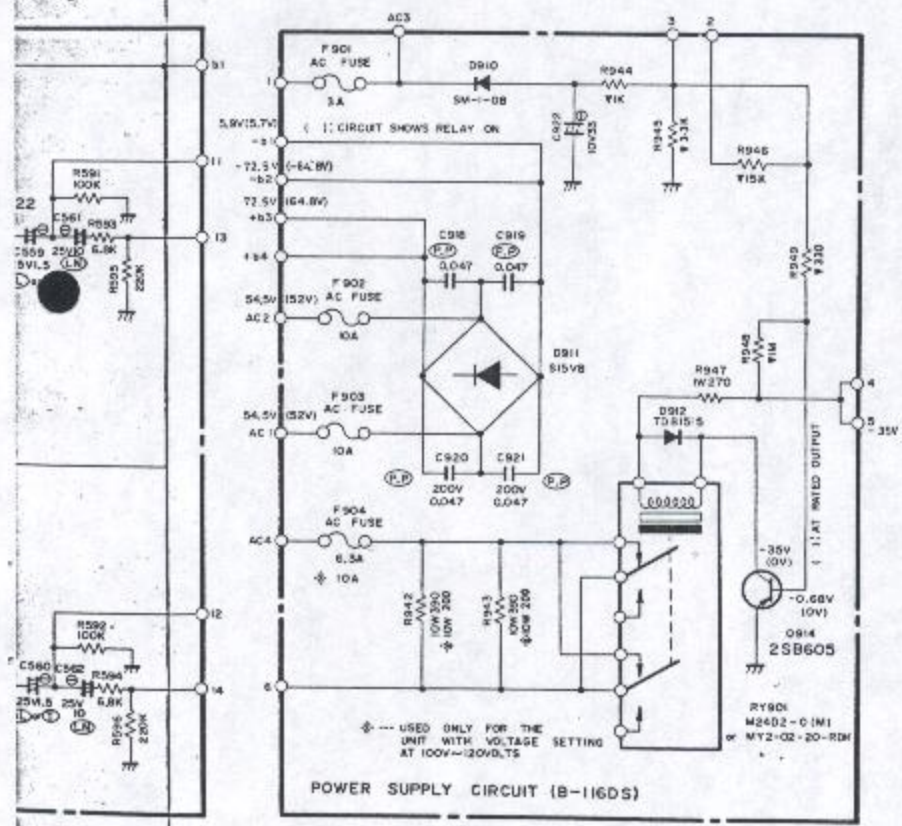
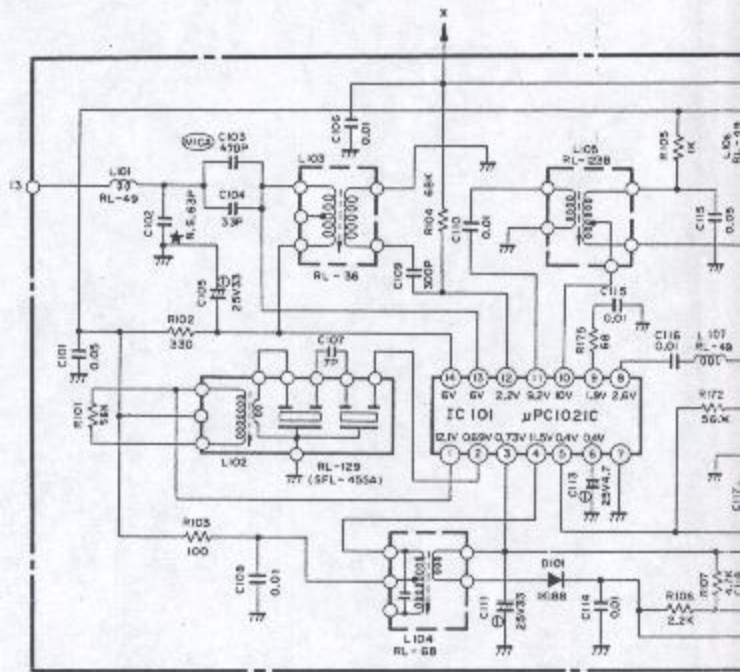
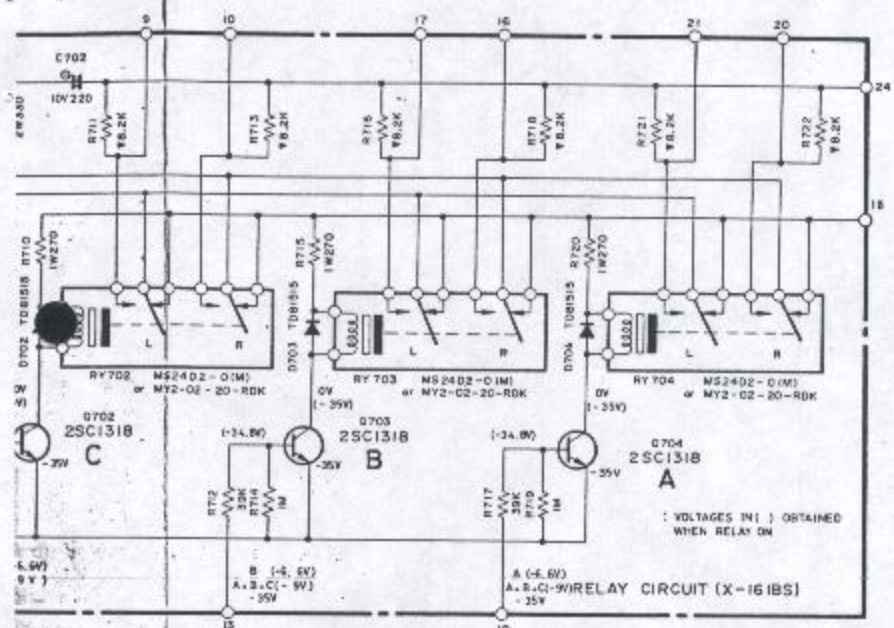

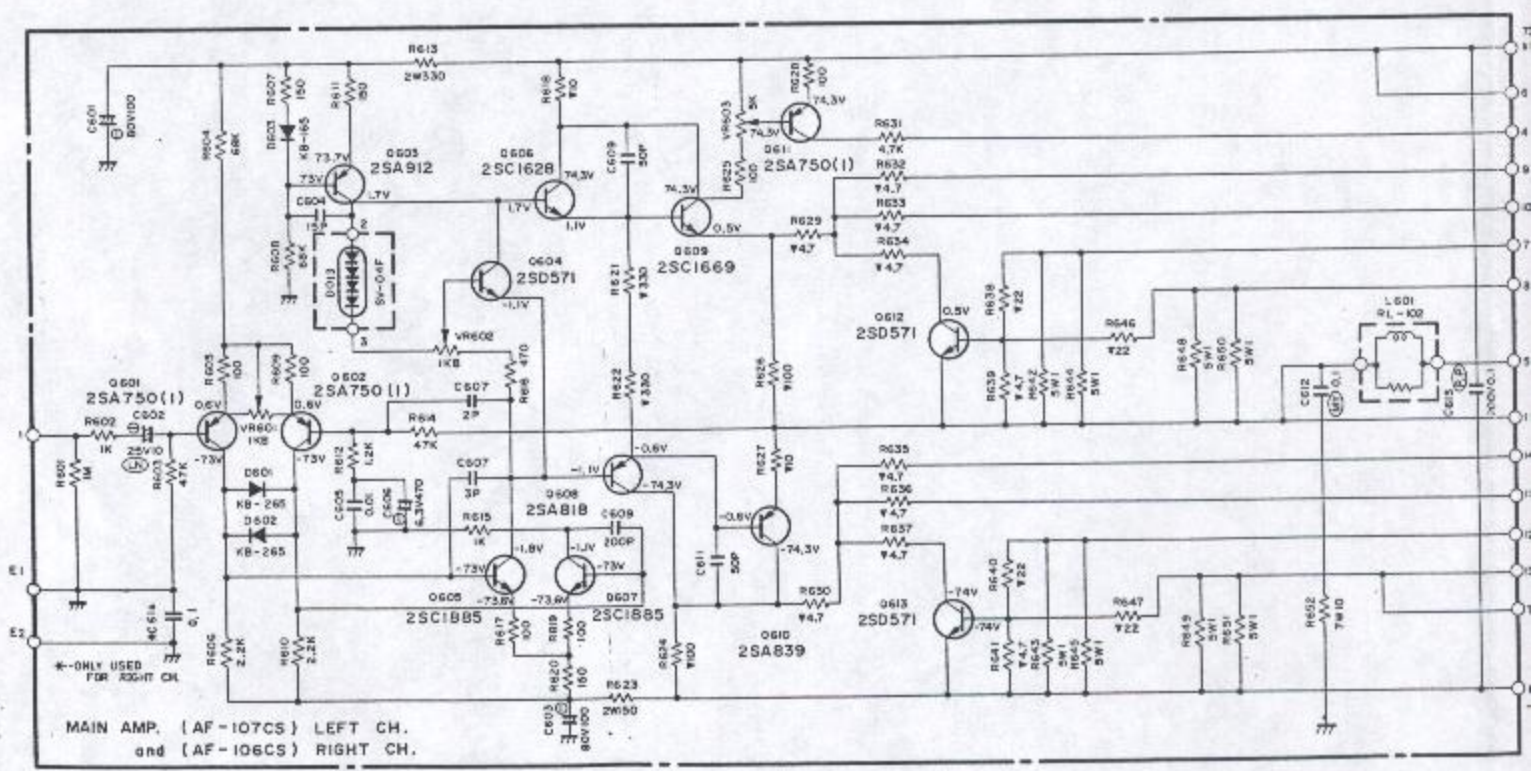
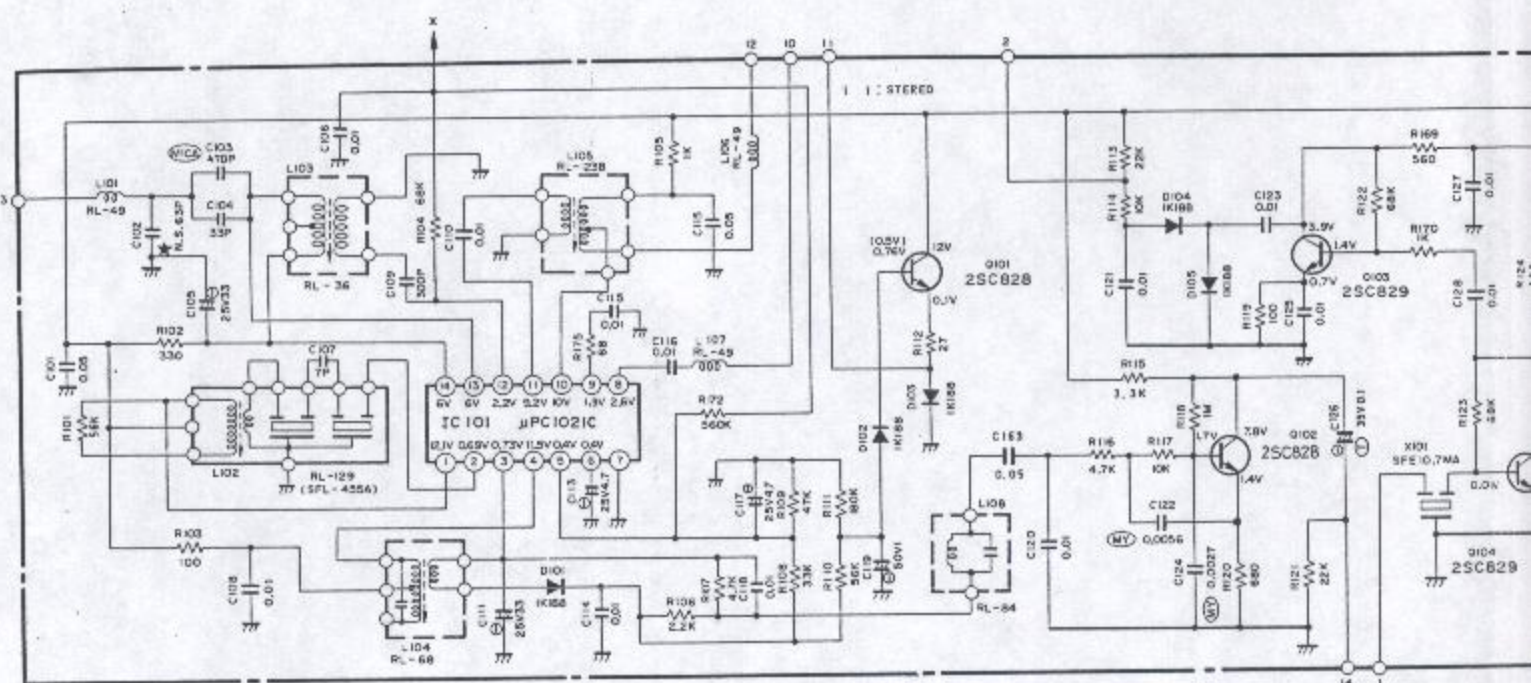

11.47
18
13
14

11.47
4
305
15W
E1
E2

(M)
20-RK

ONE CONTROL AMP CIRCUIT BOARD DIAGRAM
HALTBILD DES KLANGREGELVERSTÄRKERS
GRAMME DE PLAQUETTE DE CIRCUIT DE CORRECTEUR DE TONALITE

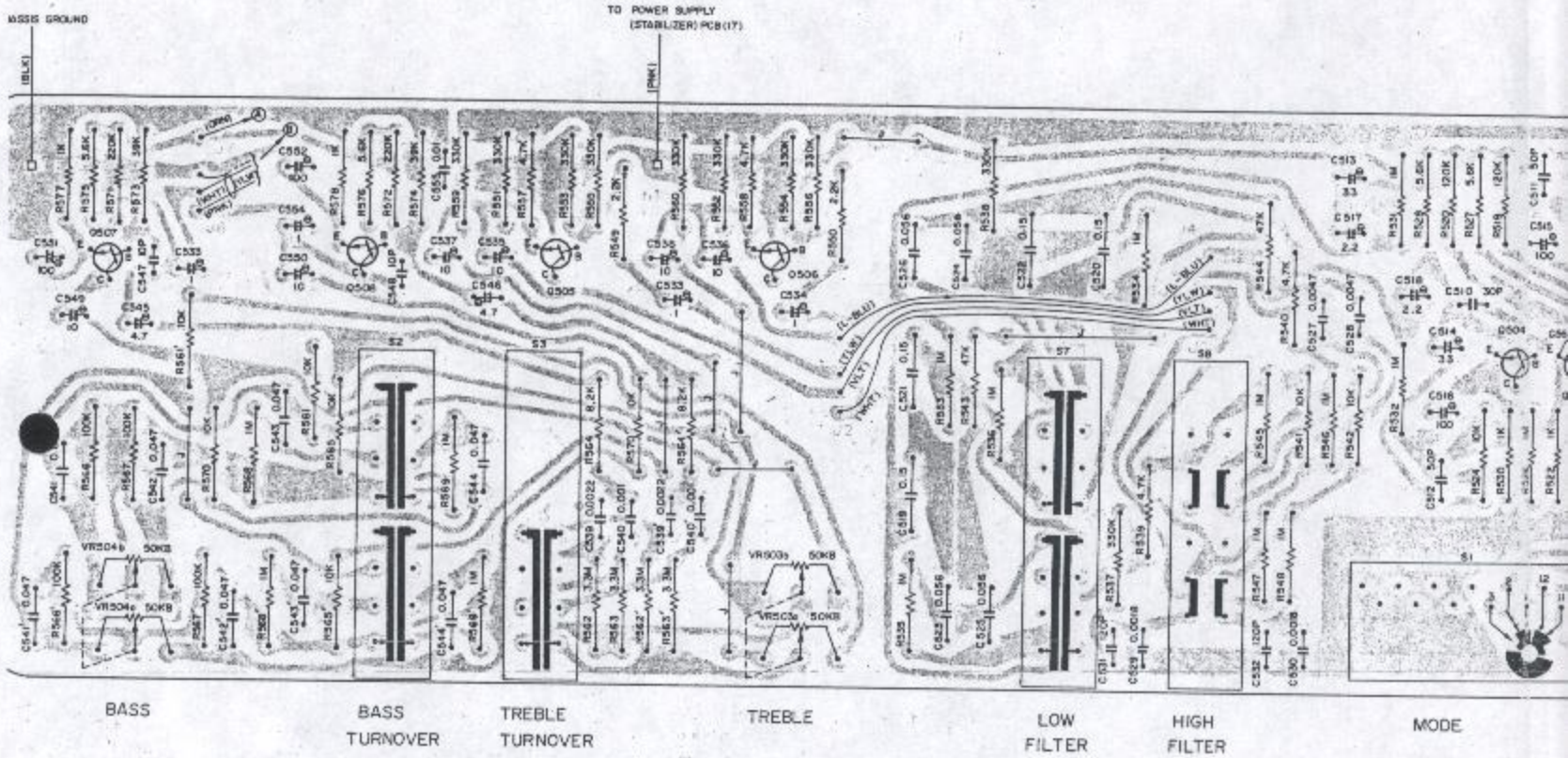

MIXING AMP CIRCUIT BOARD DIAGRAM
HALTBILD DES MIKROFONMISCHVERSTÄRKERS
GRAMME DE PLAQUETTE DE CIRCUIT D'AMP. DE MIXAGE DE MIC.

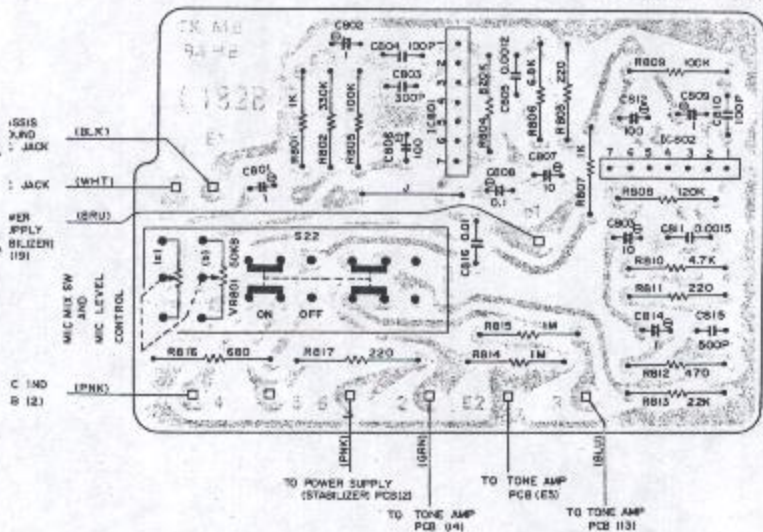

RELAY C
RELAIS-
DIAGRAM



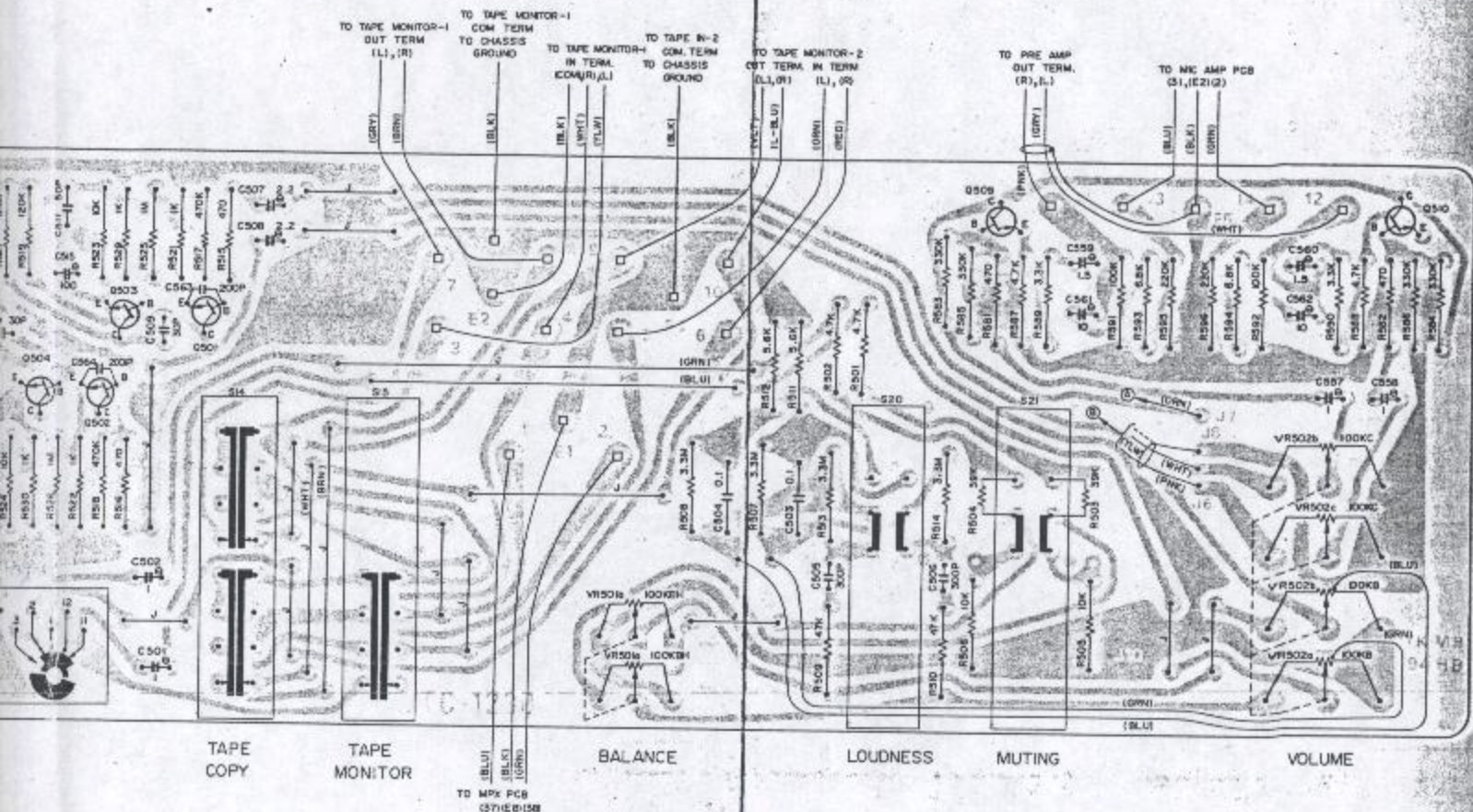

RELAY CIRCUIT BOARD DIAGRAM
 RELAIS-SCHALTBILD
 DIAGRAMME DE PLAQUETTE DE CIRCUIT A RELAIS

