

Your new Realistic TR-3000 features open reel record/playback for the ultimate in professional-type recording and tape-handling. To take advantage of the many professional features we've included in your new Deck, we urge you to take the time to read this manual carefully.

Features Include:

- Three-Head design for record monitoring and optimum frequency response. Heads are constructed of Permalloy for high wear resistance without the disadvantages of ferrite-type heads. Double-gap erase head for super quiet performance.
- Pushbutton logic-controlled tape transport allows you to switch functions instantly without tape spilling or damage.
- Solenoid operated pinch roller and reel brakes for positive, reliable operation.
- Three motor system: Frequency-generated Servo Motor maintains the capstan speed rock-steady for lowest wow & flutter. One induction motor for each reel.
- Separate bias and equalization (two-stage) for optimum quality – regardless of the tape used.
- Adjustable output control.
- Record muting switch.

For your own protection, we urge you to record the Serial Number of this unit in the space provided. You'll find the Serial Number on the back panel of the Deck.

Serial Number

**WARNING: TO PREVENT FIRE OR SHOCK HAZARD,
DO NOT EXPOSE THIS TAPE DECK
TO RAIN OR MOISTURE.**

SPECIFICATIONS

Performance Specifications

Frequency Response (Overall)

Playback [Test Tape TEAC YTT-1003 (7-1/2 ips),
YTT-1002 (3-3/4 ips)]

30 Hz – 28 kHz @ 7-1/2 ips

30 Hz – 20 kHz @ 3-3/4 ips

Signal-to-Noise Ratio (CCIR Weighted)

58 dB @ 7-1/2 ips

55 dB @ 3-3/4 ips

Cross Talk (Track-to-Track): 50 dB @ 125 Hz

Stereo Channel Separation (1 kHz): 55 dB*

Distortion (1 kHz, 0 VU): 0.9 %

Wow and Flutter (WRMS)

0.06 % @ 3-3/4 ips

Input Sensitivity

Microphone: -70 dB (0.25 mV)

Line In: -22 dB (60 mV)

Output Level

Line Out: -5 dB (0.45 V)

Headphones: -24 dB (48 mV)

Erase Ratio (1 kHz, 7-1/2 ips): 75 dB*

Rec Mute Effect (1 kHz): 73 dB*

Fast Wind Time (1800 Feet Tape): 100 sec

Take Up Motor Torque

Play: 400 gr-cm

Fast Wind: 900 gr-cm

Supply Motor Torque

Play: 250 gr-cm

Fast Wind: 70 gr-cm

General Specifications

Track System: 4 Track, 2 Channel Stereo

Head System: 3; Erase, Record and Playback

Motor System: 3; One dual-speed frequency-generated servo capstan motor. Two induction reel motors.

Tape

Reel Size: 7" (17 cm) and 5" (12 cm)

Thickness: 35 μ m

Tape Speed: 7-1/2 ips (19 cm/s) and 3-3/4 ips (9.5 cm/s)

Input Impedance

Microphone: 10 kohms or more

Line In: 50 kohms or more

Output Load Impedance

Line Out: 10 kohms

Headphones: 8 ohms

Output Level (at 0 VU): Adjustable from 0.45 Volts

Record and Playback Equalization: NAB

Bias Frequency: 100 kHz

Dimensions: 16-1/8"(W) x 12-7/8"(H) x 9-1/8"(D)
(410 x 326 x 231 mm)

Weight: 28 lbs, 11 oz (13 kg)

Power Supply: AC 120 V, 60 Hz (U.S.A., Canada)

Power Consumption: 70 W (Fast Wind Mode)

Note:

Value of "dB" refers to 0 dB = 0.775 V.

*Through a 1 kHz narrow band-pass filter.

Improvements may result in specifications or features change without notice.

TR-3000 CONTROL LOC

TAPE COUNTER: Use to aid you in locating a desired portion of a tape. The numbers are an arbitrary reference and do not represent units of time. Press the button to the right of the counter to reset it to 0000.

Reel Tables: Support the reels of tape.

Reel Holders: Provide secure mounting for reels on the reel table platform.

Tension Arms: Maintain a constant even tension on the tape.

Tape Guide Roller: Turns with the tape and eliminates wow and flutter problems.

Tape Movement and Operating Controls

REWIND Press for rapid rewind.

FAST-F Press to move tape rapidly in a forward direction.

STOP Press to stop tape movement.

PLAY Press for playback. Press simultaneously with **RECORD** for recording.

RECORD Press simultaneously with **PLAY** to set up the Deck for recording. (The red indicator light shows the deck is in the record mode.) Pressing **RECORD** only will stop all motion, preventing accidental recording.

PAUSE Temporarily stops tape motion during record or play modes. Press once to engage (a green light indicates Pause is engaged). Press again to release.

Rear Panel Connections

LINE IN (L & R): Left and Right channel inputs for recording are connected to these jacks. Use pin cord cables included in the Accessory Packet (or similar type).

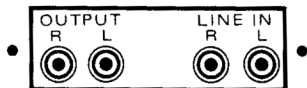

OUTPUT Terminals (L & R): Left and Right channel outputs for listening through an amplifier are connected from these jacks. Use pin patch cord cables similar to those included in the Accessory Packet.

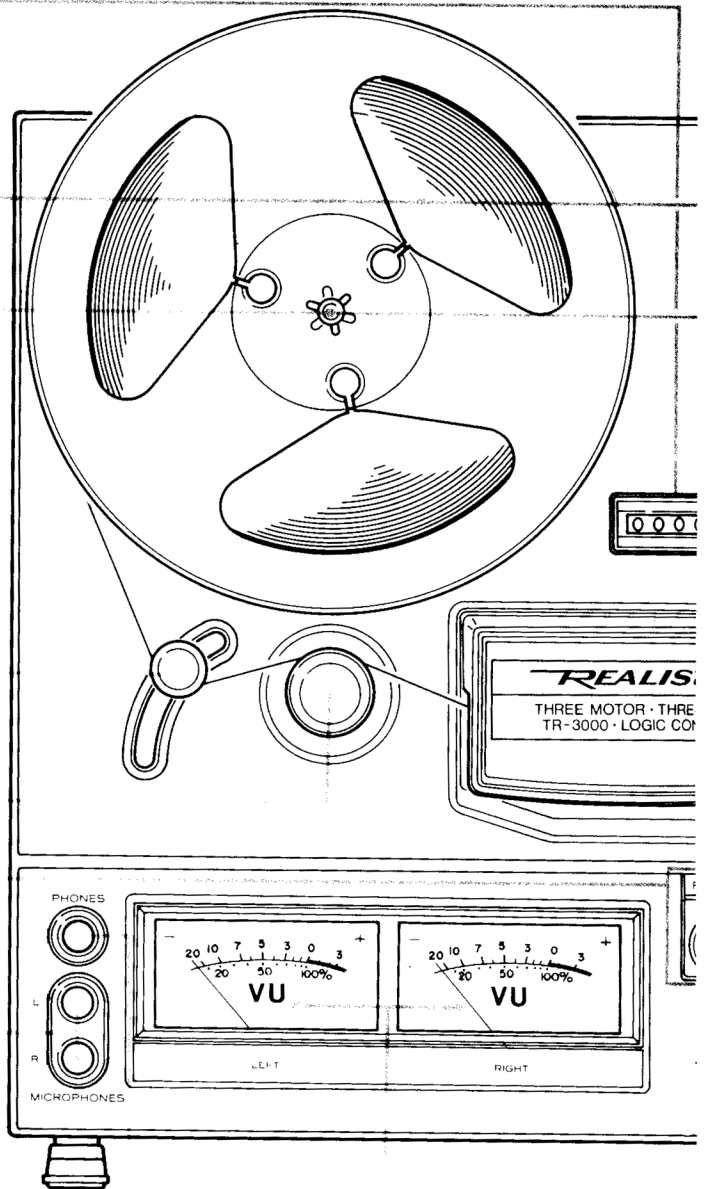

PHONES Jack: For 8-ohm stereo headphones.

MICROPHONES Input Jacks (L & R): Connections for high fidelity microphones (600 to 10,000 ohms).

VU Meters: Allow accurate level reading in either playback or record mode.

ATIONS AND FUNCTIONS

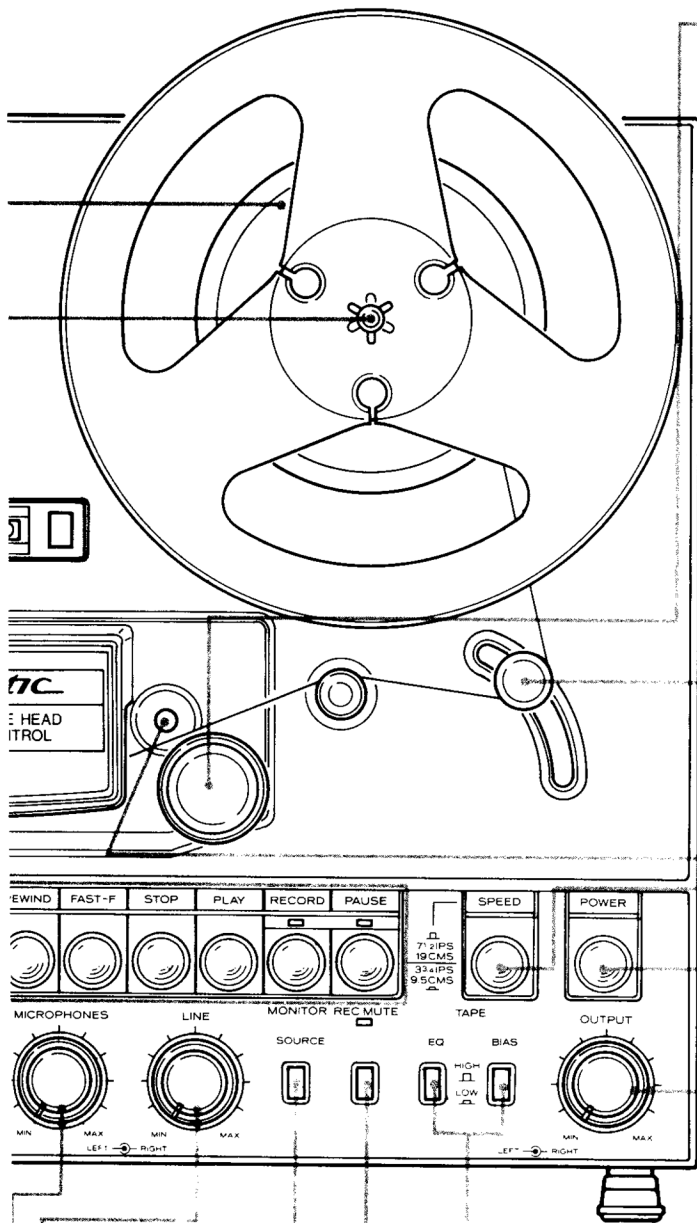

Pinch Roller: Holds the tape tightly against the capstan for uniform speed.

Shut-off Arm: The shut-off arm controls the power to the tape transport (electro-mechanical system that moves the tape). When the tape holds this arm up the capstan shaft rotates. If the tape should break or reach the end, the arm will move down and cut off power to the pinch roller solenoid; tape movement will stop, reel brakes engage and the capstan motor stops rotating.

Capstan Shaft: Drives the tape at constant speed.

Tape SPEED Push Button: This switch selects 7-1/2 ips or 3-3/4 ips tape speed. For Playback of pre-recorded tapes, press or release switch to select the speed to match the tapes. For recording, normally you'll want to use 7-1/2 ips (for the very best results, especially to increase the high frequency response). The 3-3/4 ips speed is usually used to get more tape economy when high end frequency response is not a critical consideration (such as when recording speech or background music).

POWER: Turns the Deck on and off. Press once for on (VU meters will light). Press again to turn off.

OUTPUT: Adjusts the output signal level going to your Amplifier/Receiver. Can also be used as a volume control when listening through headphones.

MONITOR Push Button: Selects the signal to be monitored. Press button in (to the SOURCE position) to hear the source input signal. Press again to release to the Tape position (button out) to hear the signal that has just been recorded on tape (or to hear playback signal).

LINE Level Controls: Use to control the signal level from a LINE input terminal (rear connection terminal) when recording sources such as a tuner, amplifier or another tape deck.

MICROPHONES Level Controls: Use to set recording input level for microphone recording.

BIAS and EQ: Different brands of tape require different levels of bias and equalization. Bias and EQ are low when the buttons are in. Leave out for high bias and EQ. (See chart-page 16.)

REC MUTE: A special feature for stopping recording without stopping tape motion during commercials, etc. While button is held in, no recording takes place (although tape is being erased). Release to resume normal recording.

HOOKING UP THE TR-3000

It's simple to connect your TR-3000 to the rest of your system. Just refer to the illustration.

CAUTION: Make sure the **POWER** switch is **OFF** and the **AC** cord is unplugged before making any connections.

Using one of the patch cords provided, connect the **Left** and **Right** **OUTPUT** jacks to the corresponding tape input jacks of your stereo **Amplifier/Receiver**.

Use the other patch cord to connect the **LINE IN** jacks to the **TAPE OUT** (or **RECORD OUT**) jacks on your **Amplifier/Receiver**.

Plug the line cord into an **AC** outlet.

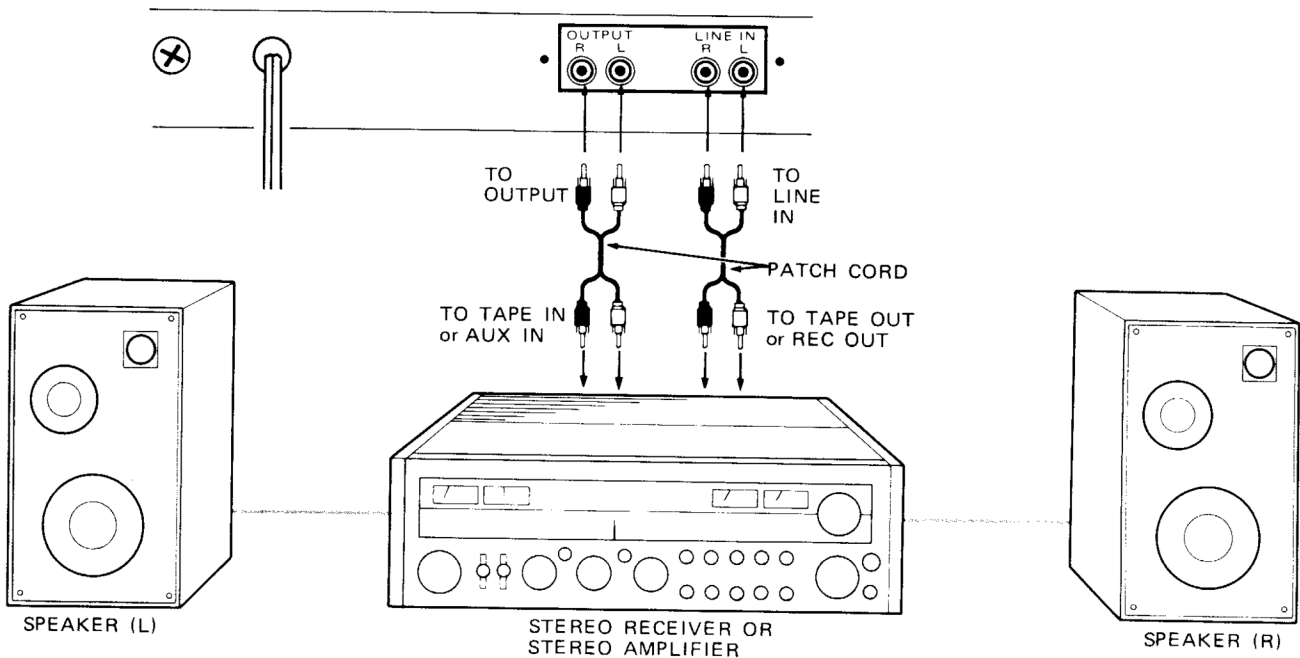

Stereo Headphones

You can use Stereo Headphones to monitor the recording process and signal, or to listen to a tape being played back. This gives you complete private monitor/listening capability. Your Radio Shack store has some very fine headphones to choose from. We strongly recommend that you obtain a pair.

To use them, just plug them into the **PHONES** jack at the front of the Tape Deck.

Microphone Connection

For "live" recordings, connect microphones to the **MICROPHONES** jacks on the front of the Tape Deck. To fully realize the dynamic range, low noise and wide frequency response of this Deck, you should use good microphones. Your local Radio Shack store has a wide selection of microphones (and other accessories). Ask your salesperson for advice on what to use.

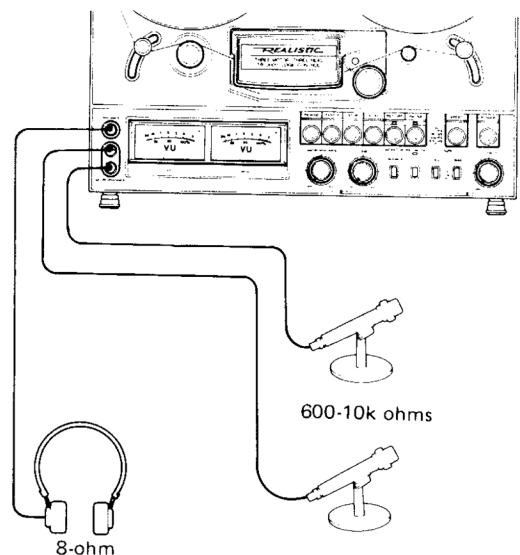

GETTING STARTED

To get the highest quality recordings with your TR-3000, we recommend you use the highest quality recording tape (such as Radio Shack SUPERTAPE® GOLD 1800; high bias).

High-output/Low-noise tapes will take advantage of the outstanding quality of your TR-3000 recording system. Avoid the long, ultra-thin tapes; they can result in stretching and "print-through" problems.

See the Tape Selection Table on page 16 for equalization and bias settings.

If you'll be using tape that has already been recorded on, the tape should be bulk-erased for the best quality. (Use the Radio Shack No. 44-210 to erase the tape **completely** in about 10 seconds.)

For normal applications, the double-gap erase head in the TR-3000 will erase all old signals.

Loading Reels

Always secure the "quick-lock" reel holders before operating the deck, to assure solid support for the tape reels.

Procedure:

1. Rotate upper section either right or left until it clicks.
2. Line up the slots on the reel with the projections on the reel holder and push the reel down until it's firmly seated.

3. Rotate upper section right or left until it clicks, locking the reel into position.

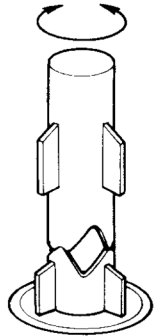

Threading the Tape

Place the full reel of tape onto the left reel table. Secure the reel holder. Place an empty take-up reel on the right reel table. Make sure the take-up reel is the same size as the full reel. (Mismatched reels are unbalanced and can upset the logic control circuit of your TR-3000, resulting in uneven breaking action.) Secure the reel holder as described above. Note that the tape must leave the full reel on the left side.

Unreel (pull out) carefully approximately 30 inches (75 cm) of tape from the supply reel. Thread this tape as shown in the illustration.

Secure the end of the tape to the take-up reel by holding the end of the tape in the slot while rotating the reel several turns CCW (counterclockwise).

Continue rotating the take-up reel until the tape is no longer loose.

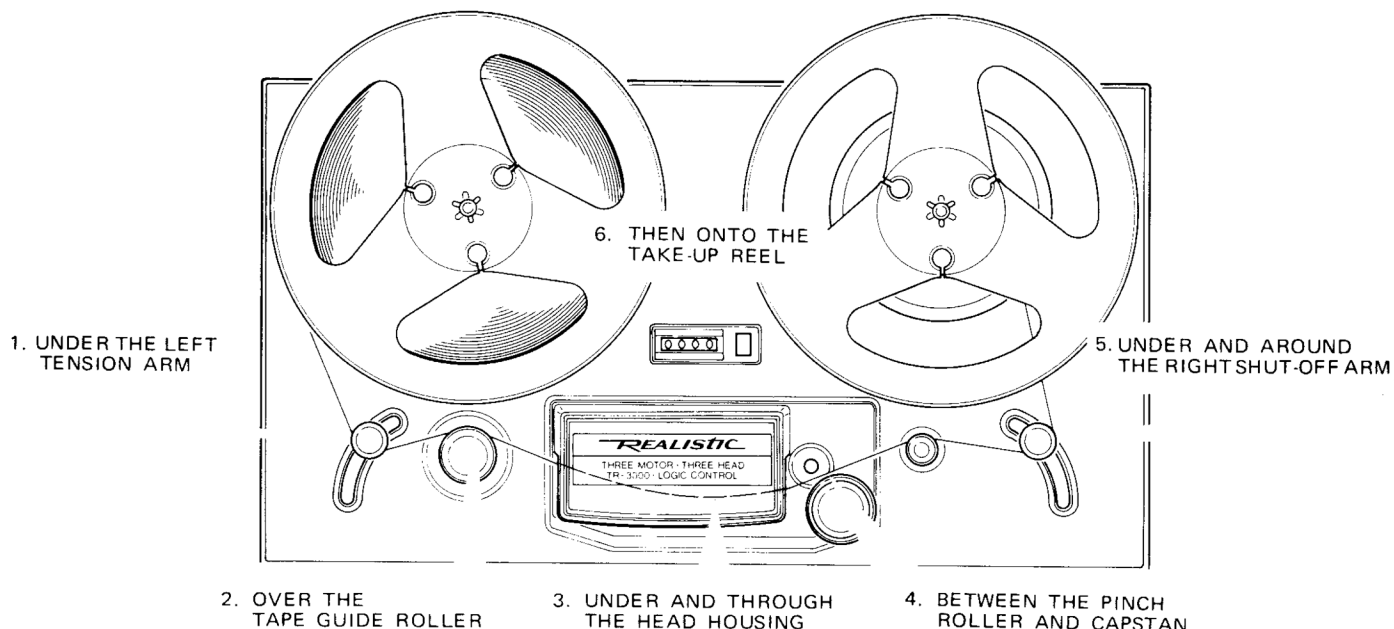

Selecting the Tape Speed

Your TR-3000 has the choice of two tape speeds: 3-3/4 or 7-1/2 ips (that's inches-per-second). For the best quality (especially for high-frequency response) use 7-1/2 ips; it also gives you a better signal-to-noise ratio and wider dynamic range.

Use 3-3/4 ips for tape economy when high-end frequency response is not a critical consideration. It's best for recording voice or background music.

Making the Recording

You can make recordings from line sources (FM, records, etc.) or from microphone(s). Signals from both sources can also be mixed.

1. Connect the Deck to an Amplifier/Receiver or plug in Microphone(s).

NOTE: When using the **MICROPHONES** jacks, one or two microphones can be used. If using one, a mono signal will be recorded on one channel (left or right).

2. Load a blank tape (see **THREADING** page 5).
3. Press the Tape Counter button (to reset counter to 0000).
4. Press **POWER** switch ON.
5. Set **SPEED** to 3-3/4 or 7-1/2 ips.
6. Set **MICROPHONES** and **LINE** input controls to MIN.

7. Set **BIAS** and **EQ** for the type of tape you're using (see chart, page 16).
8. Set **OUTPUT** control to 2-o'clock position.
9. Set **MONITOR** switch to **SOURCE** (in) position.
10. Apply the signal source (mike(s) or line).
11. Gradually turn the **MICROPHONES** or **LINE** (depending on the source) level controls for the proper channel balance and recording level. Adjust the levels so the meters swing into the red areas only on occasional peaks. (see **RECORDING HINTS** – page 9).
12. While holding down the **RECORD** button, press the **PLAY** button. (The red indicator above the button will light.)

NOTES: To temporarily stop the tape while recording, press **PAUSE**. Press again to resume recording. When you want to leave a short section of silence on the recording (such as eliminating the scratches between record selections) press and hold **REC MUTE**. As long as it is held down, no signal will be fed to the record head. To resume normal recording, release **REC MUTE**.

13. When you're finished recording, press **STOP**.

Monitoring A Recording

One of the advantages of the three-head configuration of your TR-3000 is the ability to monitor a recording while it's being made, without interrupting the recording process. Set the **MONITOR** button to its out position (Tape) and set your Amplifier/Receiver's Tape Monitor switch to **ON**. (Or use a pair of headphones connected to the **PHONES** jack.)

What you'll hear will be the actual recording . . . a split second after it's made.

NOTE: When recording from microphone(s), use headphones for monitoring. If you try to monitor through your Amplifier/Receiver, you'll end up with acoustic feedback (squealing and howling) which will ruin your recording.

External Timer Recording

Because of the logic control circuitry built into your TR-3000, you can use the Deck with an external Timer (such as Radio Shack's 63-858) to make unattended recordings.

Timer Recording

1. Set up your Receiver/Tuner for normal reception and adjust the recording level (see RECORDING, page 6).
2. Connect the power cords of both the TR-3000 and your Receiver/Tuner to the Timer outlet (use a cube-tap if necessary).

3. Refer to the Timer instruction manual and set it for the desired "on" time.

4. Press the **PLAY** and **RECORD** buttons down simultaneously. (Make sure the TR-3000 and Amplifier/Tuner switches are "on".)

At the preset time, the Timer will apply power and recording will start automatically. The TR-3000 will shut off automatically when the tape runs out; or you can set your Timer to turn off everything after the recording is finished.

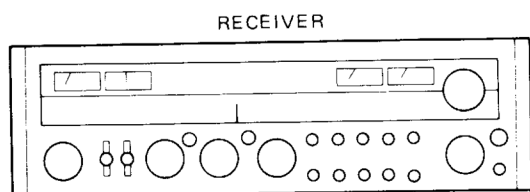

AC Line Cord

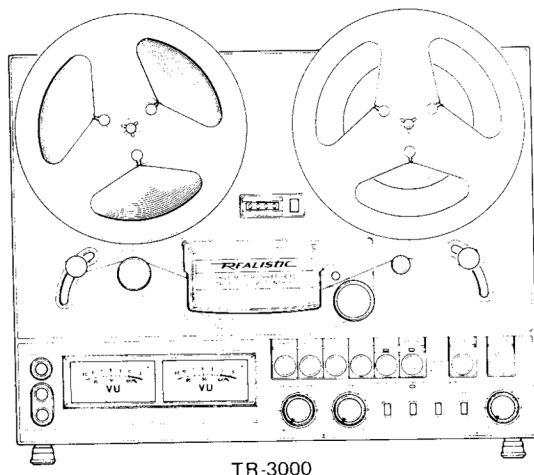

AC Line Cord

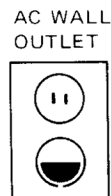
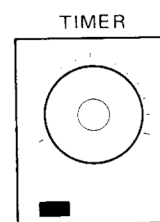

Microphone/Line Mixing

You can easily and accurately mix signals from **MICROPHONES** and **LINE** with your TR-3000. This feature is useful for mixing music and narration for slide shows, etc.

Proceed as follows:

1. Connect microphone(s) to the **MICROPHONES** jacks on the front panel. If more than two microphones are to be used, a high-quality mixer is necessary. It can be added as shown in the illustration.
2. Use Headphones to monitor the recording to prevent acoustic feedback.

3. Set the **MONITOR** button to **SOURCE**. Press **RECORD** and **PLAY**.
4. Adjust the **MICROPHONES** and **LINE** record level controls and proceed recording.

NOTE: You'll need some practice to get the best results when mixing **MICROPHONES** and **LINE**. Experiment a little. When mixing **MICROPHONES** and **LINE** best results are often obtained by keeping the **LINE** level about 25 % lower than the **MICROPHONES** level. (This prevents the music from overpowering the voice. Use Headphones to monitor the "mix".)

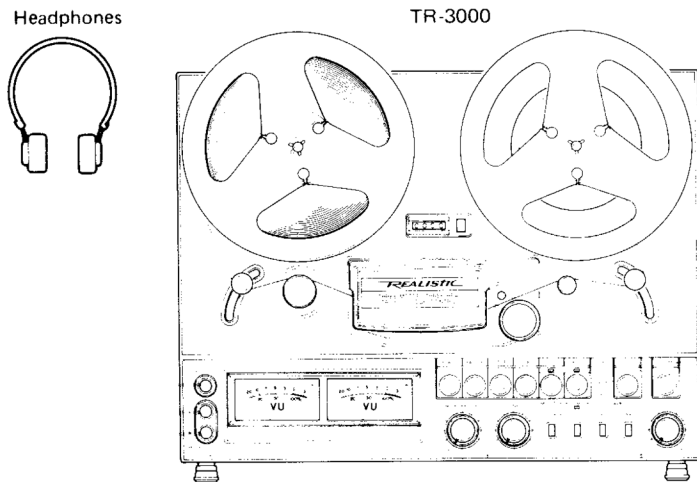

Set MIC and LINE levels to mix sources

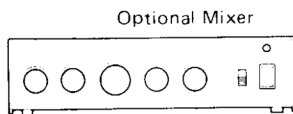

Optional Mixer

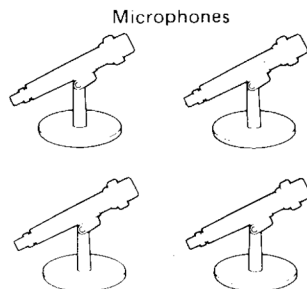

Microphones

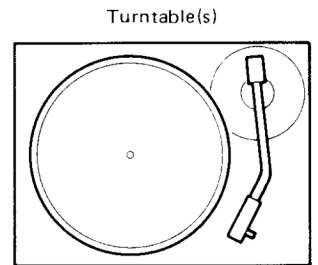

Turntable(s)

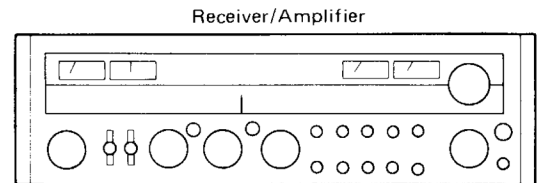

REC or TAPE OUT (Set VOLUME to minimum)

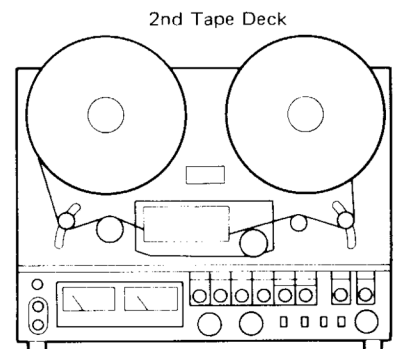

2nd Tape Deck

PLAYBACK

Playback of Pre-recorded Tapes

1. Thread the tape (see page 5).
2. Press **POWER** to turn the Deck on.
3. Press the Tape Counter button (to reset counter to 0000).
4. Since bias and equalization have no effect on playback, there is no need to concern yourself with the setting of either **BIAS** or **EQ** button.
5. Set **SPEED** switch to the appropriate position.
6. Release **MONITOR** button to the Tape position (button out).
7. Press **PLAY**. (Adjust the Volume, Tone, and Balance controls on your Amplifier/Receiver as desired.)

NOTE: The **OUTPUT Level** on the front panel of the Deck can be adjusted to match the output of the Deck with other sources (such as records, FM, etc.). Otherwise, leave it at about the middle position.

8. To temporarily stop the tape, press **PAUSE**. Press again to resume normal play.

Press **FAST-F** to move the tape rapidly forward. Press **REWIND** to move the tape rapidly in a reverse direction. The Tape Counter can be used as an aid to help you locate particular positions on the tape. The numbers are an arbitrary reference and do not reflect units of time.

To listen to tapes privately (or if you don't have an Amplifier/Receiver) plug a pair of stereo headphones into the **PHONES** jack. Volume can be adjusted by using the **OUTPUT Level** control.

You can playback mono tapes recorded on other machines in the same manner described above. Set your Amplifier/Receiver to **MONO**, otherwise you'll get sound from only one speaker.

You can also playback two-track pre-recorded stereo tapes, although you'll have to boost the **LEFT OUTPUT** a bit. (For more on two-track stereo, see **NOTES** and **APPLICATIONS**, page 13).

RECORDING HINTS

Setting the record level is the most important factor to consider in order to obtain full advantage from your tape and top performance from your Deck while keeping distortion to a minimum.

In general, the record level is set so that the VU meter pointers only occasionally swing into the red area on the right. Experience will show you that some kinds of music, especially those which contain many sharp sound peaks such as drums or cymbals, can cause distortion in the recorded signal. When setting the record level use a loud passage from the disc you're recording. Or, if you're recording off FM, set the level a little lower to leave "head-room" for the loud passages.

A VU meter is specially designed **not** to read *short* loud sounds. It's up to your judgement and experience to set the level as high as possible without distortion. Too low a level will result in audible tap hiss when the recording is played back at normal listening levels.

Warped, bent, or poorly centered tape reels can cause damage to your tapes and degrade both record and playback. Therefore, use only high quality reels. A dirty tape path can also degrade your Deck's performance sharply. (See **CARE** and **FEEDING**, page 14).

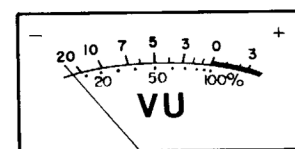

LEFT

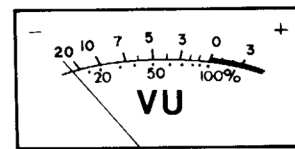

RIGHT

Microphones

Live recording with microphones is an "art" in itself, but don't be afraid to experience the excitement and fascination of making your own recordings with a pair of Realistic microphones.

Your local Radio Shack has a microphone for every purpose, from at-home recordings to live on-stage performances. Knowing the broad distinction between microphone types will help you make the right choice.

There are two basic pickup patterns: cardioid and omnidirectional.

CARDIODES pick up sound from the front in a tight pattern. They're best for stage work, music recording, and public address applications where feedback (acoustic "howling") could be a problem.

OMNIDIRECTIONALS have a circular pick-up pattern that receives sound from almost any direction (including in back of the microphone). They'll get

good sound pickup from almost anywhere in an average sized room and are especially good for making live recordings of orchestras and other large groups.

Both the Cardioid and Omnidirectional also come in two different types:

DYNAMICS are rugged and versatile, great for at-home recording and heavy-duty on-stage work where dependability is important.

ELECTRET CONDENSERS provide super-sensitive sound pickup along with a wide and flat response. The best electrets are used for critical studio work. The internal circuitry of electrets require a battery which normally lasts six to nine months.

Microphone Placement

Microphone placement for stereo recording depends on many factors, from the size of the room to the number of people recorded. Experiment with mike placement for the best fidelity and stereo effect.

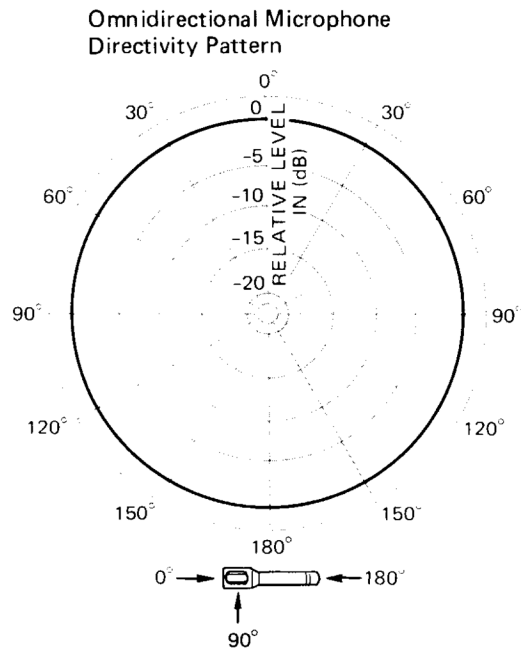
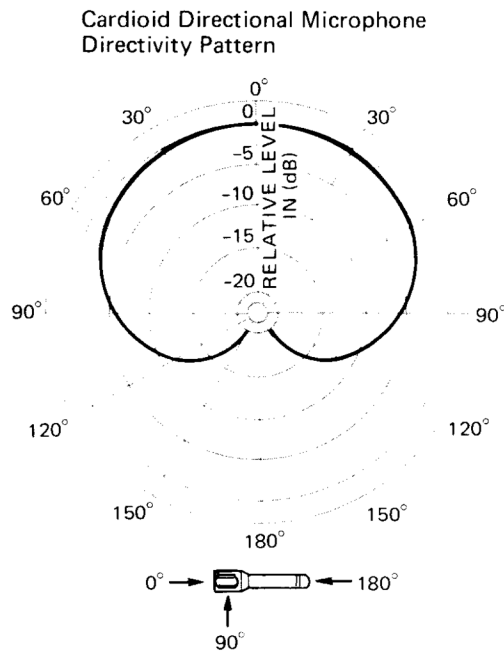

More Hints

Your local Radio Shack has a book, *Realistic Guide to Tape Recorders* which has a number of chapters covering the practical aspects of tape, recorders and accessories, plus a number of hints to enhance your enjoyment of your TR-3000 Deck. Using multiple mikes for each channel is something

you might want to get involved with as you become more advanced. A mike mixer will get you involved in advanced professional recording.

Your local Radio Shack has a wide selection of mike and tape accessories; stop by and take a look.

RADIO SHACK TAPE ACCESSORIES

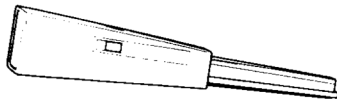

Head Demagnetizer

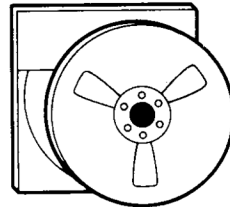

Metal Take-up Reel

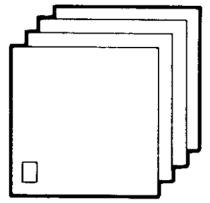

Reel Storage Cases

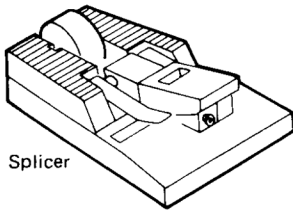

Splicer

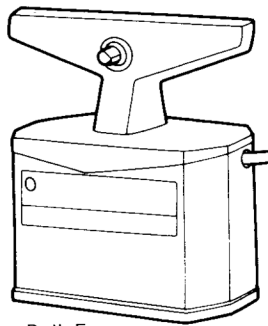

Bulk Eraser

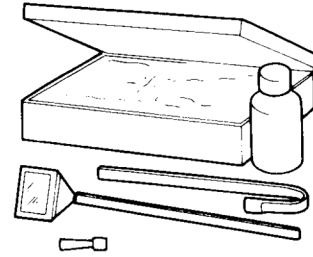

Recorder Care Kit

Dubbing

Deck-to-Deck copying of tapes (dubbing) can be done without an external Amplifier/Receiver. The **LINE OUT** jacks of the master-recorder are connected to the **LINE IN** jacks of the Recorder that will be doing the copying. You can use the standard patch cords included with your TR-3000.

The TR-3000 can be used as the "master" record with a second recorder used as the "slave". Connect the output of the TR-3000 to the input of the slave recorder. To use the TR-3000 and the second recorder in opposite roles, simply reverse the connections.

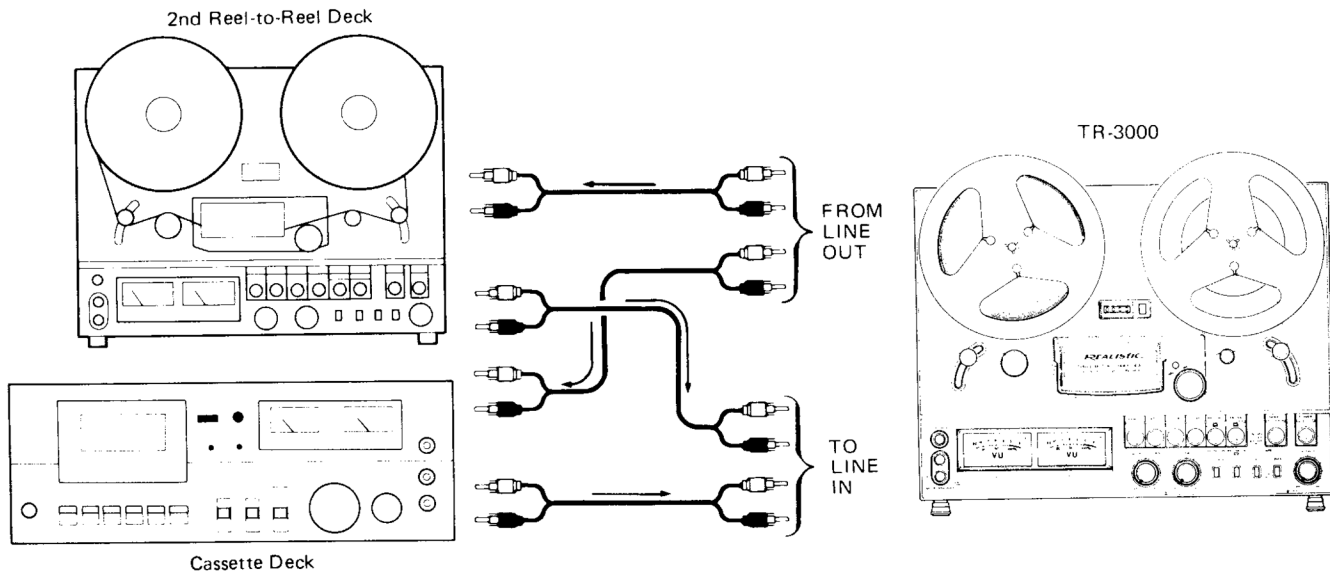

SPLICING AND EDITING

One of the biggest advantages of open reel decks is the ability to make creative recordings by eliminating or joining different segments into one tape. Reel tapes are also much easier to edit.

You can edit and splice with scissors or a razor blade, but we strongly recommend you purchase a tape splicer such as Radio Shack's 44-212 to do the most professional splicing job. Follow the instructions provided with it. You'll also need splicing tape (Catalog No. 44-1125). **Never use ordinary adhesive tape for splicing.**

For a quick editing and splicing job, you can use scissors by doing the following (**do not use scissors which are magnetized**):

1. Overlap the ends to be spliced by about 1/2" (15 mm) and align them carefully.
2. Cut through the center of the overlapped area at about a 45-degree angle.

3. Butt the ends of the tape sections together. Use a straight-edge or ruler to ensure good alignment.
4. Apply splicing tape to the shiny base side of the tape (opposite the side that touches the heads).
5. Place the splice on a flat hard surface and rub down the splicing tape with your finger or other object.
6. Trim off the excess splicing tape. Cut very slightly into the tape to remove all excess.

IMPORTANT: If you've recorded on both sides of the tape, make sure the part you splice will not spoil the recording on the other side. If you plan to do much editing, it's a good idea to record on one side of the tape only.

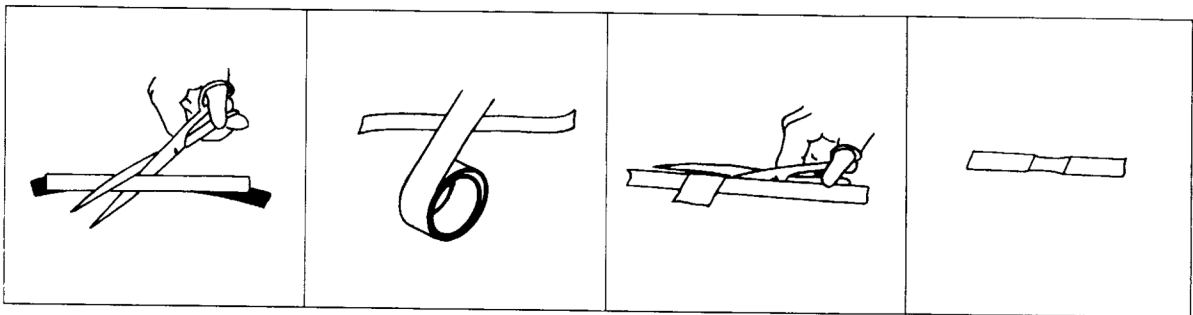

NOTES AND APPLICATIONS

4-Track Stereo Recording and Playback

A blank tape, of course, has no tracks on it. Until it's recorded, the tape can be used for any configuration of tracks. The record head determines the track configuration. If the head records the same signal

over the entire width of the tape, it's called full (or single) track. If half the tape is recorded, it's called half (or two) track. If four sections are recorded, it's called quarter (or four) track.

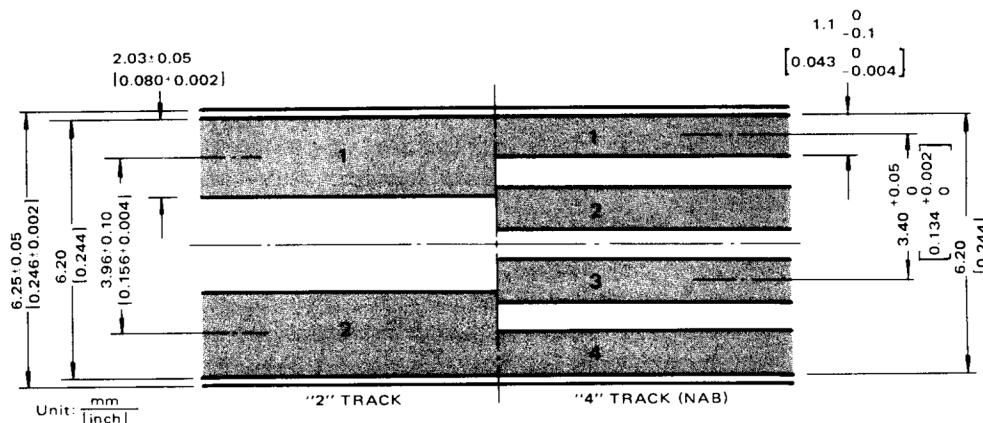

Your TR-3000 uses 4-track record/playback. In this configuration, two tracks (stereo) are recorded simultaneously. The first time the tape passes the record head, tracks 1 and 3 are used. The reels are then interchanged and the other two tracks (2 and 4) are recorded. The left channel sounds will thus be recorded on tracks 1 and 4 and the right channel sounds on tracks 3 and 2.

A 4-track deck such as your TR-3000 can replay both 4-track and 2-track tapes and from the standpoint of

compatibility has the widest range of utilization. When playing a 2-track stereo tape on your TR-3000, track number 1 will be completely covered by the head. Track number 2 will be slightly misaligned but you can enjoy normal stereo by compensating for the slight loss of track number 2 by using the **OUTPUT** control.

You can also playback 2-channel monaural tapes by rotating the right channel **OUTPUT** control to **MIN**.

4-TRACK RECORDING

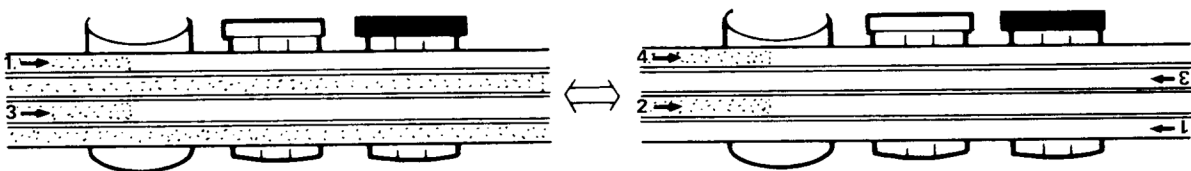

CARE AND FEEDING

Although your Tape Deck is well constructed, it's a precision electronic device with limits to be considered. To ensure a long and trouble-free life for your Deck, keep the following factors in mind when you install and operate it.

Don't operate your deck near heating equipment, on top of an Amplifier/Receiver, or in direct sunlight. Avoid any temperatures higher than 100°F (38°C).

Avoid extreme low temperatures also. Temperatures lower than 40°F (5°C) will cause lubricants to harden. Operation will be sluggish and the drive motors could be overloaded.

High humidity locations will shorten equipment life due to corrosion and possible fungus growth on printed circuit boards.

Your TR-3000 is a precision machine and as such should be protected from dust. Operation in a dusty environment will result in excessive head wear. Your tapes should be kept as dust-free as possible by always being stored in boxes.

To insure proper operation of all moving parts in your TR-3000, periodic lubrication is a must. At least once a year, you should bring your Deck into your local Radio Shack for standard lubrication and preventative maintenance by our Service Technicians. Never attempt to lubricate it yourself.

Cleaning

To get optimum performance from your Deck, it must be kept as clean as possible; dirty heads will cause a reduction in high-frequency response, irregular head wear, dropouts, and in extreme cases the Deck may not record at all.

The **most** important point in tape deck maintenance is frequent and proper cleaning of the heads and tape path including the tape guides, tape lifters, tension arms, capstan shaft and pinch (pressure) roller.

The heads should always be cleaned before making a recording, and at least once for every eight hours of use. The new tape formulations leave a gray or white residue that's often difficult to detect. Therefore, you should institute a regular cleaning schedule. (Your local Radio Shack has everything necessary to clean your Deck.)

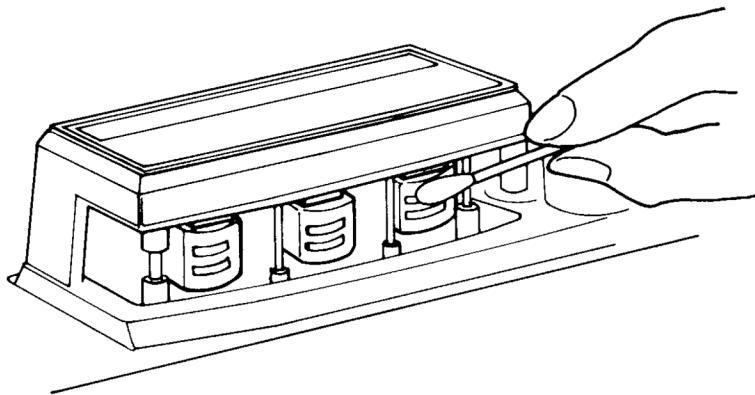

Head Demagnetization

After long periods of use, the heads may become slightly magnetized. As a result, high-frequency response will decrease, noise will develop, or in extreme cases, high-frequencies will be erased on your valuable pre-recorded tapes.

To keep your Deck operating at its original fidelity the heads should be demagnetized at least once after every 25 hours of use. Use the Radio Shack N 44-207 Demagnetizer and follow the instructions.

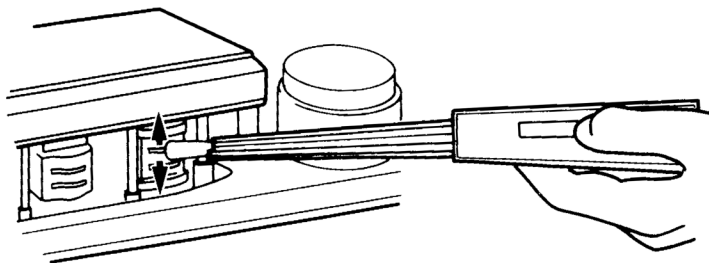

Storage and Handling of Your Tapes

Magnetic tape recordings are superior to records because, with proper care, they can be kept and replayed for many years without degradation.

During playback, the biggest danger to the recording is a magnetized or dirty point on the Deck, such as a head or capstan. (See above.)

Protect your tapes from dust. Keep them in the plastic bag and original carton they were packed in.

Protect your tapes from temperature extremes; avoid freezing temperatures, direct sunlight, and other sources of heat.

Protect your tapes from stress; tremendous pressure is built up on the inner windings of the tape. This problem is increased if the windings are irregular. Frequent starts and stops will cause uneven winding. If you're planning to store your tapes for a long period of time, it's a good idea to store them "tails-out" by storing the full take up reel and rewinding it before playing. Tapes stored after rewind often have uneven windings.

Protect your tapes from strong magnetic fields; just as a bulk eraser will erase recorded material, a strong magnet, electric motor, or coil of transformer could affect your recording.

EQUALIZATION AND BIAS

To get the widest dynamic range, best signal-to-noise ratio and flat frequency response during playback, your recordings must be made with the correct settings of **BIAS** and **EQ** switches, to match the type of tape you are using.

So you won't have to refer to the chart everytime you record a reel, it's a good idea to mark the **BIAS** and **EQ** switch settings on the reel or the tape storage box. You should realize that **BIAS** and **EQ** have no effect on playback (they only function in the record mode).

BIAS and EQ Setting Chart

Brand	Type	Switch Position	
		EQ	BIAS
REALISTIC	SUPERTAPE GOLD	HIGH □	HIGH □
AMPEX	407	LOW ▢	HIGH □
BASF	LP-35LH, LP-35LHS, LPR-35LH	HIGH □	LOW ▢
FUJI	FB	HIGH □	HIGH □
FUJI	FG	LOW ▢	HIGH □
FUJI	FM	LOW ▢	LOW ▢
MAXELL	LN	LOW ▢	LOW ▢
MAXELL	UD-XL, UD, New-LN	HIGH □	HIGH □
SCOTCH	207	LOW ▢	HIGH □
SCOTCH	212, 229	HIGH □	LOW ▢
SCOTCH	MASTER	HIGH □	HIGH □
SONY	DUAD, ULH	HIGH □	HIGH □
TDK	L Series (AUDUA)	HIGH □	HIGH □
TDK	S Series	LOW ▢	LOW ▢

If the tape you're using is not included in the list, use low BIAS and low EQualization.

Tape Timing Chart

Speed \ Length	ONE-WAY		ROUND-TRIP	
	7-1/2 ips (19 cm/s)	3-3/4 ips (9.5 cm/s)	7-1/2 ips (19 cm/s)	3-3/4 ips (9.5 cm/s)
600' (185 m)	15 mins.	30 mins.	30 mins.	60 mins.
900' (277 m)	23 mins.	45 mins.	45 mins.	90 mins.
1200' (370 m)	30 mins.	60 mins.	60 mins.	120 mins.
1800' (555 m)	45 mins.	90 mins.	90 mins.	180 mins.

IN CASE OF PROBLEMS

PROBLEM	CAUSE	CORRECTIVE ACTION
TAPE TRANSPORT		
Completely inoperative, VU Meter lamps not illuminated	Power cord loose, not connected	Connect power cord
	Fuse blown	Replace fuse; 2nd time, see Radio Shack Service Center
Capstan does not rotate (tape does not move). VU Meter lamps illuminate	Auto-shutoff arm not lifted	Correct the arm position and/or rethread the tape
Tape squeal noise	Tape rubbing reel	Reels not properly installed. Reset reels
	Pinch roller dry or tape needs lubrication (silicone)	Use tape lubricating cloth to apply silicone lubrication to the entire tape or replace the tape
PLAYBACK OPERATION		
No Sound	Disconnected Audio cord	Check and secure connections on the deck and stereo amplifier system
	MONITOR Switch mis-positioned	Place MONITOR Switch to TAPE
	OUTPUT Level too low	Increase OUTPUT Level Control
Poor sound quality	Dirty tape heads	Clean heads.
	Worn or defective tape	Replace tape
Unstable sound (Wow/Flutter, pitch changes in signal)	Pinch roller dirty	Clean
	Dirty tape path	Clean entire tape path with head cleaner
	Tape rubbing against reel	See above for tape squeal noise
RECORDING OPERATION		
Does not record, cannot hear audio at SOURCE MONITOR position. No VU Meter reading	Input cable loose or not connected	Check cord at deck and at Amplifier/Receiver
	Record Level too low	Increase Record Level controls
Does not record, cannot hear audio at TAPE MONITOR position	OUTPUT Level too low	Increase OUTPUT Level setting
	Dirty tape heads	Clean heads
Sound quality is low, dull, too much tape hiss, etc	Dirty tape heads	Clean heads
	Worn or defective tape	Replace tape
	Insufficient Record Level	Increase Record Level
	Heads or tape path magnetized	Demagnetize tape path and heads
	BIAS/EQ switches not set properly	Set BIAS/EQ switches to match tape
Distorted or garbled sound	Distortion from excessive Level	Reduce Record Level setting

If you still have problems, bring your Deck into your nearest Radio Shack. We'll get it back into working condition ASAP!

BLOCK DIAGRAM

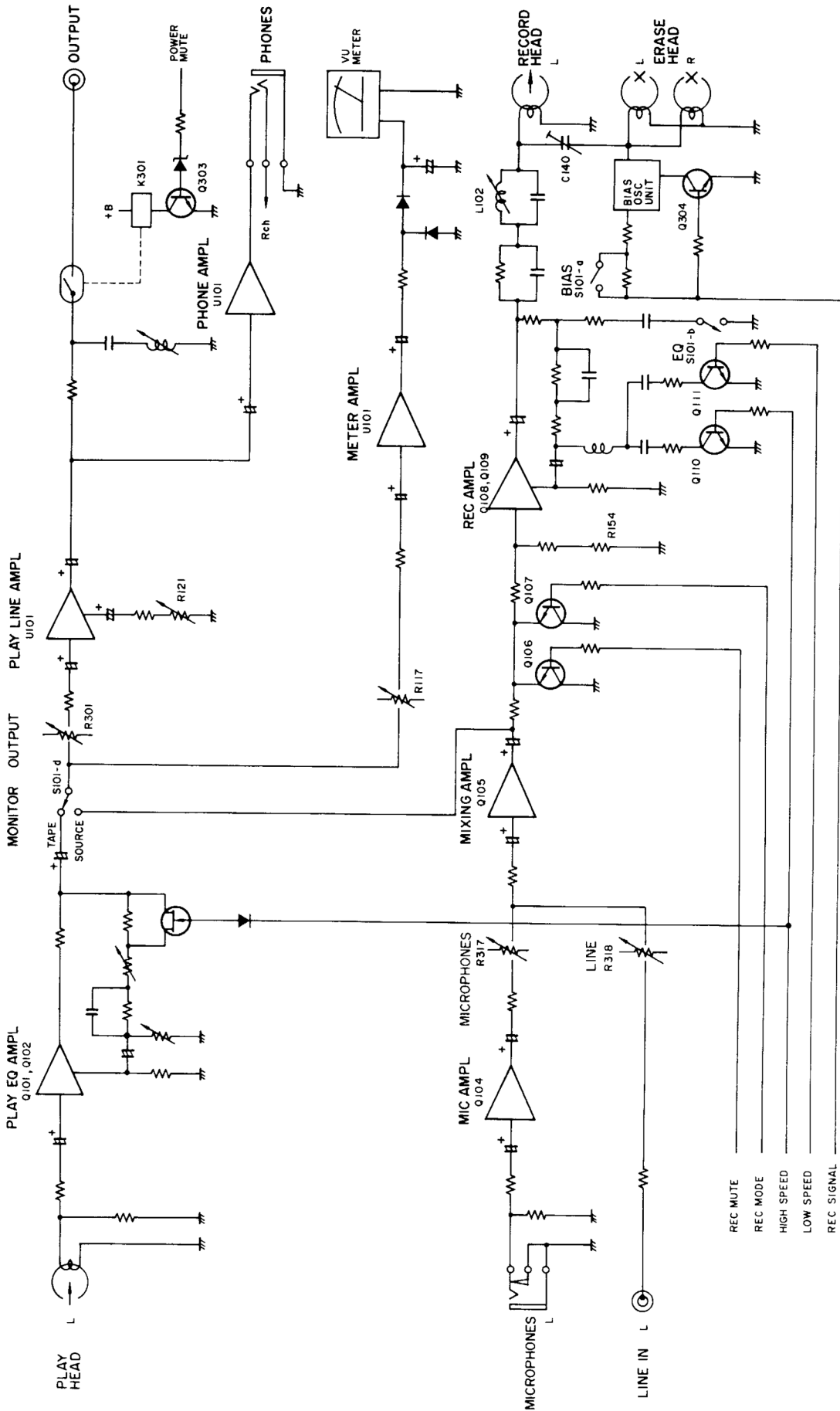

SCHEMATICS

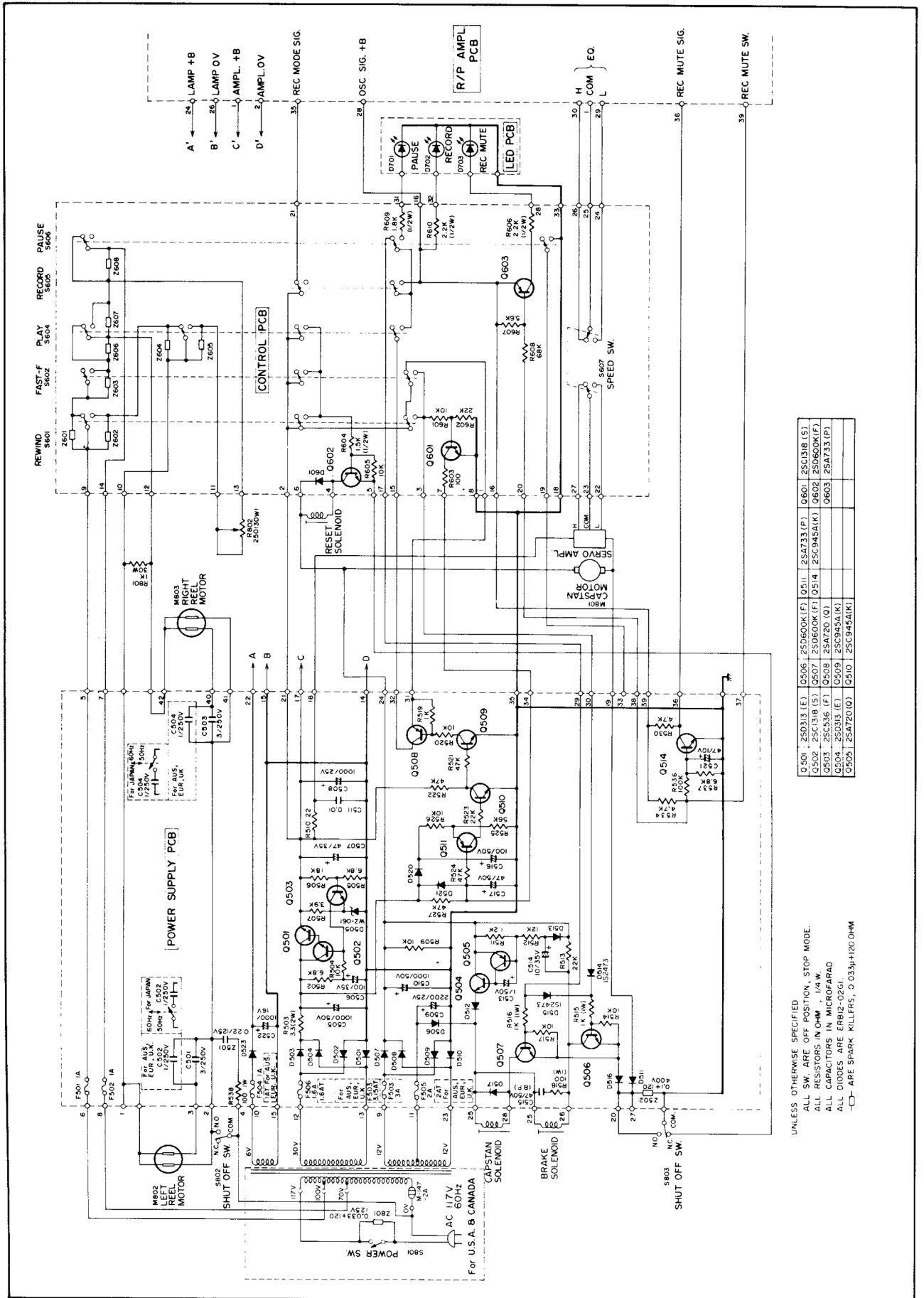

UNLESS OTHERWISE SPECIFIED
 ALL SW. ARE OFF POSITION, STOP MODE.
 ALL RESISTORS IN OHM, 1/4 W.
 ALL CAPACITORS IN MICROFARAD
 ALL DIODES ARE ERB12-02G1.
 □ ARE SPARK KILLERS, 0.033μH±10% OHM

Q501	2SD0313 (E)	Q506	2SD600K (F)	Q511	2SA1733 (P)	Q601	2SC1318 (S)
Q502	2SD0318 (S)	Q507	2SD600K (F)	Q514	2SC945AK1	Q602	2SD600K (F)
Q503	2SD0316 (F)	Q508	2SA1720 (Q)			Q603	2SA1733 (P)
Q504	2SD0315 (E)	Q509	2SC945AK1				
Q505	2SA1720 (Q)	Q510	2SC945AK1				

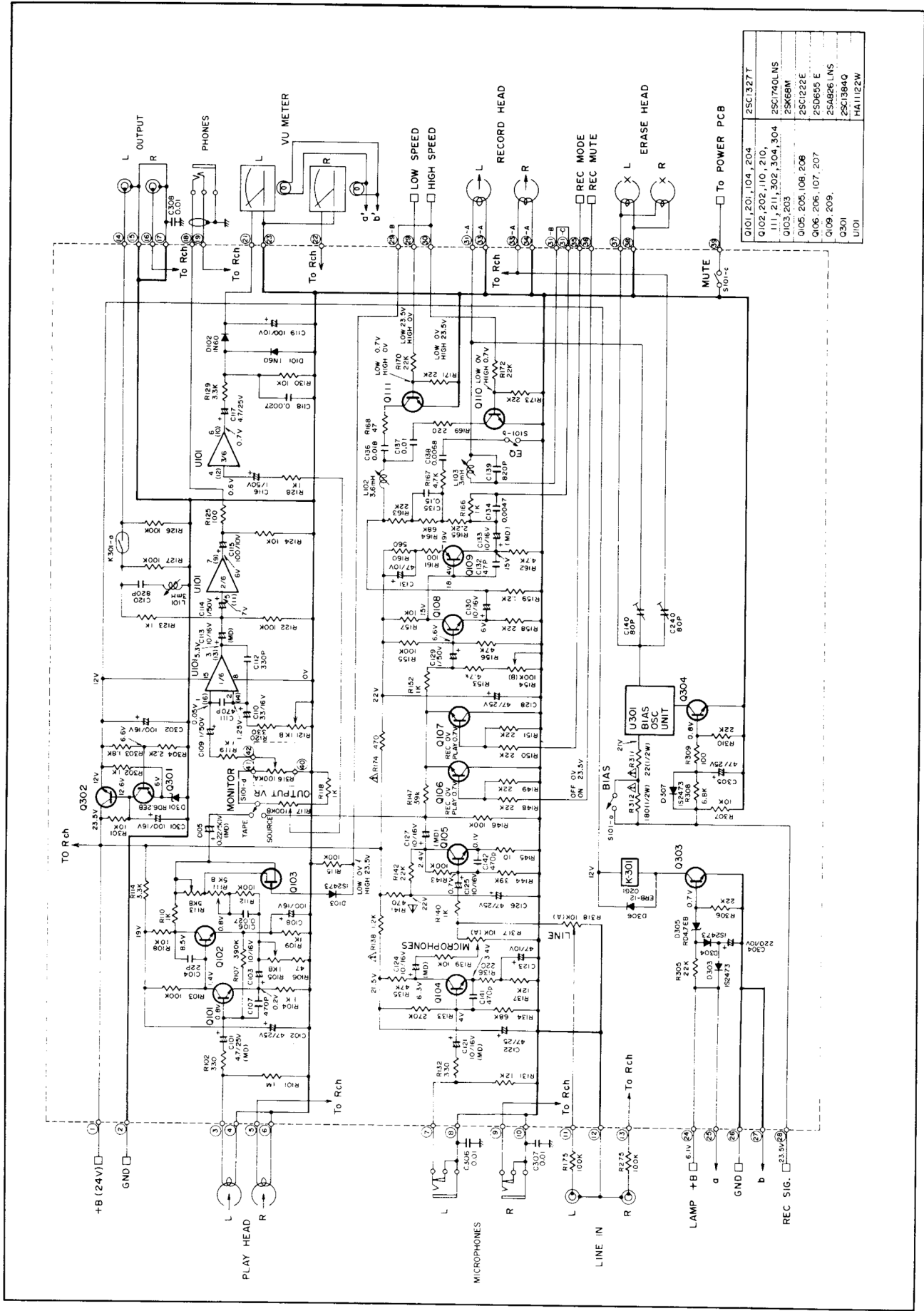

Q101, 201, 104, 204	25C1327T
Q102, 202, 110, 210,	25C1740LNS
111, 211, 302, 304, 304	25K68M
Q103, 203	25K68M
Q105, 205, 108, 208	25C1222E
Q106, 206, 107, 207	25D695 E
Q109, 209	25AB86 LNS
Q301	25C1384Q
U101	HA1122W