

AM/FM Stereo Receiver

with Quatravox[®]

STA-64

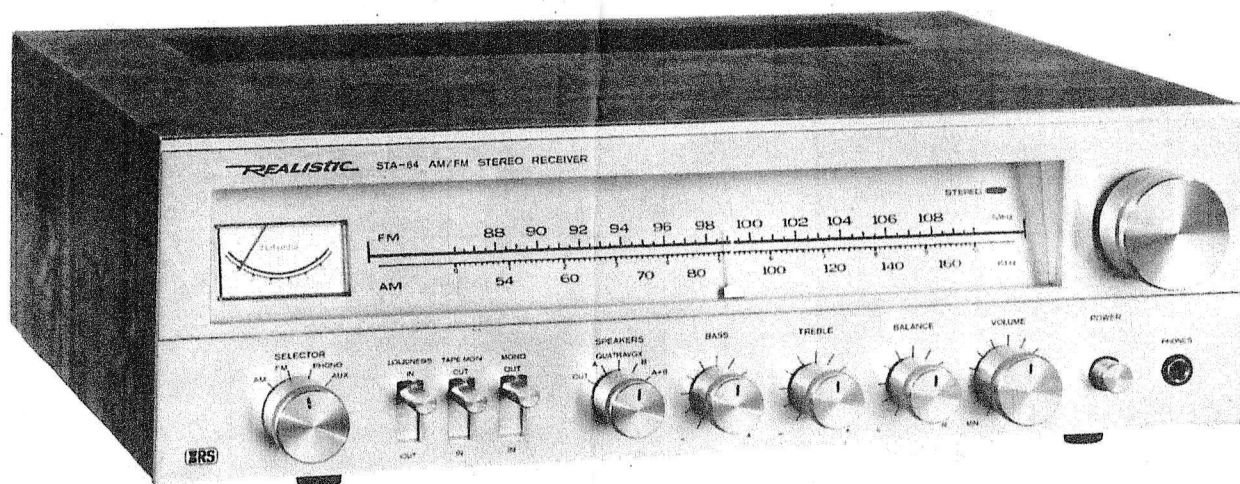

OWNER'S MANUAL

PLEASE READ BEFORE
USING THIS EQUIPMENT

REALISTIC[®]

Cat. No.
31-2073

CUSTOM MANUFACTURED FOR RADIO SHACK  A DIVISION OF TANDY CORPORATION

REALISTIC[®]

THE BRAND WITH OVER 1,000,000 CUSTOMERS

In choosing this fine Realistic product you have demonstrated a rather acute awareness of the good old American custom called "getting the most for your money". With Realistic this is not an idle boast.

The "line" was born in Boston, long famous for Yankee ingenuity — and thrift. Its original intent was to bridge a gap between \$100 equipment and \$25 equipment where, at the time, there was a real void in hi-fi merchandise.

Early products were a \$39.95 FM tuner, a \$29.95 preamp/amplifier, a \$19.95 speaker. Soon we found ourselves a unique niche as manufacturing retailers.

Capacity and ability grew simultaneously. Our Realistic Electrostat-3[®] electrostatic tweeter was called a "best buy" by the country's leading product-review magazine. Our 10TRF radio out-performed practically anything then available. And dealers from all over the world began requesting a Realistic franchise.

Recent "firsts" include: the first medium cost DC/AC communications receiver totally engineered in solid state — the Realistic DX-150A; the first properly designed low-cost police band radio — the Realistic Patrolman; the Realistic Optimus-1 loudspeaker, bringing "over \$120 sound" down 33%; the first lifetime-guaranteed vacuum tube; and the Realistic STA-120B stereo receiver which combined massive power, modern styling, and a veritable host of new ideas — at a cost fully \$100-\$200 below its value under traditional marketing practices.

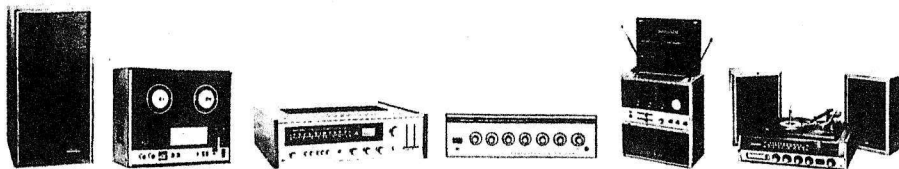

Speakers Recorders Components P.A. Products Radios Phonographs

REALISTIC AUDIO PRODUCTS are the proud result of Radio Shack engineering, research, development, and over 50 years of experience in electronics. Laboratories are maintained in Boston, Ft. Worth, Los Angeles, and abroad. In every sense a national brand, the Realistic label is worn with equal distinction by our highly original Communications and Citizens Band (two-way radio) products, and numerous other items including: tape, headphones, antennas, intercoms, and tubes.

General Description

Your STA-64 represents one of best values available today in a high-quality receiver. Its power and versatility make it an outstanding buy.

- 16 watts of clean "honest" power will drive almost any speaker system — even two sets of speakers!
- The FM front-end section utilizes a "Field Effect Transistor". This means that your Tuner has extra-high sensitivity combined with exceptionally low noise, an unusual immunity to distortion caused by electrical interference at these high frequencies and minute signal levels. Maybe that's a little too "technical" for you — but it's all solid up-to-the-minute engineering technology.
- The FM multiplex section employs a newly developed Phase Lock Loop IC (or P.L.L. IC) which assures stable stereo separation even if internal temperatures rise or drop.
- Built-in Quatravox® simulates 4-channel effects from stereo sources — and it only requires a second set of stereo speakers.
- Built-in overload protection circuitry automatically shuts off the amplifier under excessive load conditions.
- A wideband tuner gives hi-fi sound even on AM.
- A factory-mounted genuine walnut veneer case, and you don't pay a penny extra.
- Silver styled panel with hair-line finish makes this an elegant component — suitable for any decor or system.

NOTE: Before connecting the STA-64, please read the following instructions. They will insure your getting the most enjoyment from your new receiver.

RADIO SHACK LIMITED WARRANTY

This equipment is warranted against defects for 2 years from date of purchase. Within this period, we will repair it without charge for parts and labor. Simply bring your sales slip as proof of purchase date to any Radio Shack store. Warranty does not cover transportation costs. Nor does it cover equipment subjected to misuse or accidental damage.

This Warranty gives you specific legal rights and you may also have other rights which vary from state to state.

We Service What We Sell

Specifications

Preamplifier-Amplifier

Audio Output Power at no more than 0.8 : 16 watts
% Total Harmonic Distortion into 8 ohms, (Minimum RMS Power, both channels driven).
over the audio spectrum, 20 to 20,000 Hz

RMS Output (1 kHz) 22 watts per channel
(less than 1% THD, both channels driven)

Frequency Response 15–30,000 Hz

Sensitivity (for full output) PHONO : 2.5 mV

AUX : 150 mV

Tape In : 250 mV

Tape Output Level 250 mV

Tape Output Level (DIN) 25 mV

Signal-to-Noise Ratio PHONO : 65 dB

AUX : 70 dB

Tape : 75 dB or better

Tone Control Action Bass : ± 10 dB @ 100 Hz

Treble : ± 10 dB @ 10 kHz

Crosstalk 60dB

Loudness Compensation ± 9 dB @ 100 Hz

(–30 dB Volume) ± 4 dB @ 10 kHz

FM Tuner

Sensitivity (IHF) 2.2 μV

Limiting Sensitivity (–3 dB) 3 μV

Signal-to-Noise Ratio (1 mV) 65 dB

Stereo Separation (1 kHz) 35 dB

Image Rejection 50 dB

Harmonic Distortion Mono : 0.5 %

Stereo : 0.6 %

Capture Ratio 2 dB

IF Rejection 80 dB

ACA 70 dB

AM Suppression 46 dB

AM Tuner

Sensitivity Radiated : 200 μV/m for 20 dB S+N/N

Terminal : 10 μV

Distortion (5 mV/m) 1.5 %

Image Rejection 45 dB

Signal-to-Noise Ratio 45 dB

ACA 28 dB

AGC Figure-of-Merit 45 dB

IF Rejection 32 dB

Antennas

Built-in ferrite AM; Linecord FM. Plus terminals for external antennas.

Power Requirements

120 volt AC, 60 Hz (200 watts max.)

(220/240 V AC, 50 Hz for European and Australian models as indicated on rear of unit.)

A Typical System: STA-64, Turntable, 4 Speaker, Tape Deck

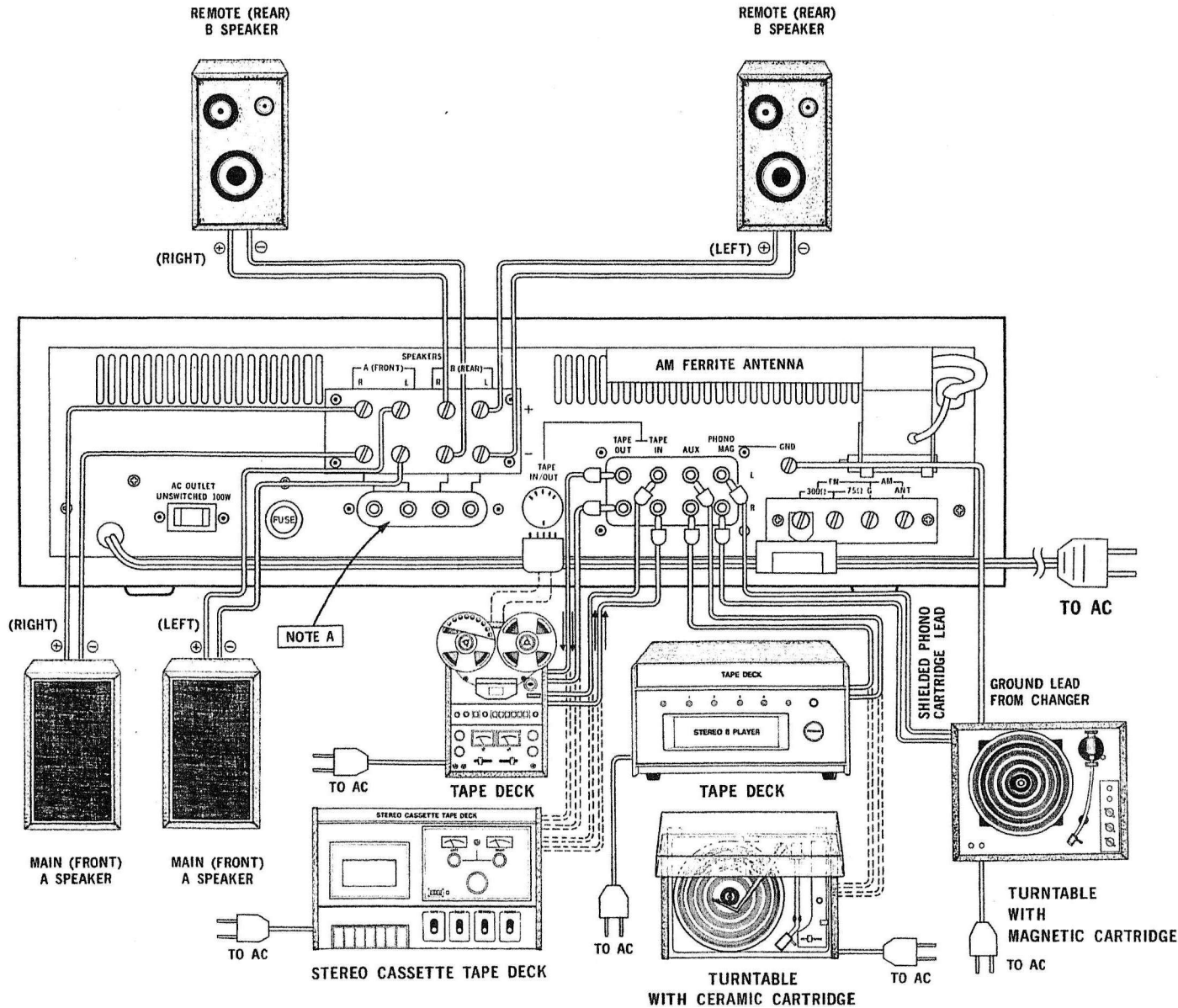

[Note A]:
 For Main (FRONT/A)
 Speaker pair and
 Remote (REAR/B)
 Speaker pair if leads
 have RCA-type phono
 plugs only.

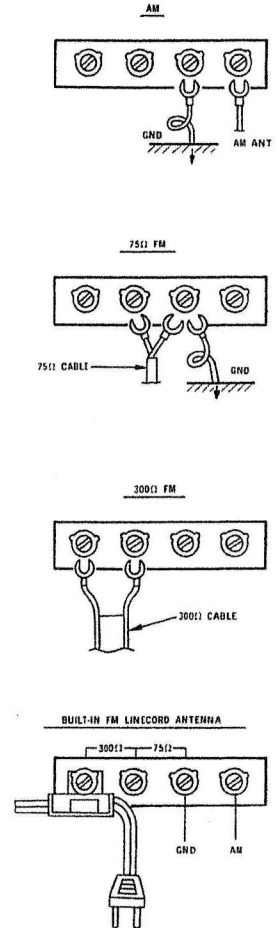

Connecting the STA-64

SPEAKERS

No stereo system sounds better than its speakers. So we recommend you buy the best speakers you can afford, especially for the main (or front) speakers. The Realistic **Minimus**® series should represent a basic level while the **Optimus**® or **Nova**® series would be preferable. The remote (or rear) speakers can be the same or less expensive, although the Realistic **Solo**™ series should be a minimum.

The STA-64's built-in Quatravox lets you hear sounds from your stereo records that you've never heard before. By just adding a second set of stereo speakers this circuit simulates 4-channel sound.

Most stereo recordings contain ambient (reflected) sound which an ordinary stereo system loses. Quatravox plays these sounds through the rear speakers and actually recreates the acoustics of the studio or concert hall. The degree of 4-channel effect varies with the type of music you listen to and the way it was recorded.

If your speakers have RCA phono jack connectors, hook them up to the RCA jacks on the Receiver's rear panel. If your speakers have only screw terminals, use two-conductor lamp or speaker wire to connect them to the screw terminals on the STA-64. Connect the main/front speakers to "A (FRONT)" and the remote/rear speakers to "B (REAR)".

NOTE: When using the screw terminals be sure to observe proper polarity. Most speaker wire is clearly marked with a raised line along one conductor, or has one wire a different color from the other. Connect the (+) receiver output with the (+) or "marked" (color dot or other marking) speaker terminal, and the (-) output to the (-) or unmarked speaker terminal. Do not allow stray strands of wire to touch adjacent terminals or the metal chassis.

NOTE: Use no more than four speakers with the STA-64. You must choose between remote speakers and Quatravox (since you can not use both remote speakers and rear Quatravox at the same time).

To prevent continual tripping of the automatic overload protection circuit, use 8 or 16 ohm speakers if you plan to use more than one pair of speakers. If you use 4 ohm speakers, **use only one pair**; either for "A" (Front) or "B" (Rear), but **not both**. See Page 8 for notes on **Overload Protection**.

PHONOGRAPH

For convenience most people prefer a record changer (often called an automatic turntable) to a manual turntable. Realistic, Miracord, Dual, BSR and Garrard all make good automatic turntables. Be sure your turntable has a magnetic cartridge with an output of at least 2.5 mV.

Connect your turntable shielded cables to the PHONO MAG receiver inputs. You may plug the turntable's linecord into the AC OUTLET (UNSWITCHED) or into a wall socket.

To minimize hum, connect the turntable's green or black ground wire to the GND (ground) screw on the rear panel.

TAPE DECK

Until recently, reel-to-reel tape machines were the only choice for people seriously interested in hi-fi. But recently vast improvements have been made with cassettes; for example, the widespread use of Dolby noise reduction and the introduction of high-performance tapes. The best cassette decks now rival reel-to-reel machines.

Eight-track recorders have only slightly less fidelity than cassettes or reel-to-reel, but have several advantages. You can play car tape cartridges at home and save money by recording your own tapes. In addition 8-track cartridges are continuous loops, will play for hours and require no attention.

Using shielded cable connect the STA-64's TAPE OUT jacks to the tape recorder's input, usually labeled AUX/LINE IN. Connect the tape deck output to the Receiver's TAPE IN jacks. Plug the deck's line cord into the AC OUTLET (UNSWITCHED) or into a wall socket.

A second tape player (8-track, cassette or reel-to-reel) can be connected to the AUX Input jacks. Thus, you can play tapes when using the AUX position of the Selector switch.

Any other high-level sound source can be connected to the AUX Input jacks — another tuner, a record player with ceramic or crystal cartridge, TV sound, etc.

If your tape recorder has a DIN-type socket, use a cable with DIN-type connectors and plug into the DIN-type socket on the Receiver.

FM and AM ANTENNAS

The built-in antennas are adequate for most areas, for other antenna provisions see the illustration on the facing page, also page 9.

Front Panel

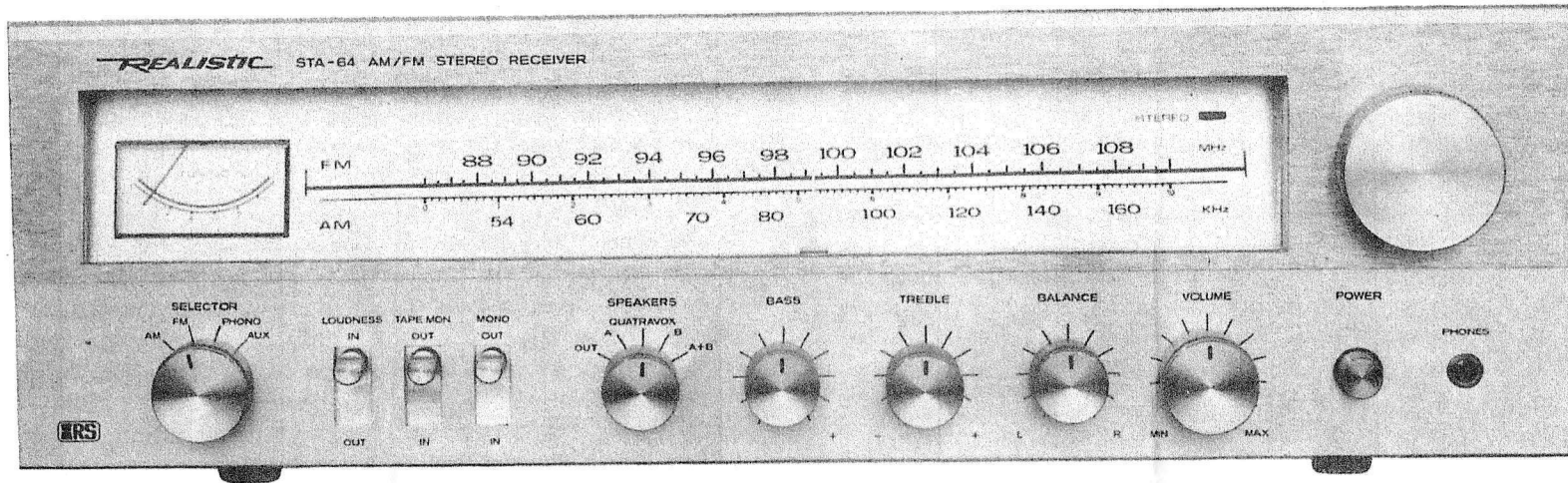

Before plugging the receiver in—

- Check the **POWER** switch, put it in its "out" position.
- Put the "flip" switches in the upper position.
- Turn the **VOLUME** fully counterclockwise (MINimum position).
- Make connections as shown on Page 4.

OPERATING INSTRUCTIONS

Press the **POWER** switch to turn the unit on. Select one of the inputs by turning the **SELECTOR** switch to the desired source.

Set the **SPEAKERS** switch to the desired position. "A" selects the main/front speakers only; "B" selects only the remote/rear speakers. "A+B" plays the same program through both sets of speakers. "QUATRAVOX" feeds slightly different signals to the "B" speakers, which then function as the rear sound for simulated 4-channel sound. The "OUT" position permits you to turn off all the speakers for head-phone listening.

Adjust **VOLUME** to the desired level. Turn the **BALANCE** control until you feel a slight catch near the 12 o'clock position. At this position the two speakers play with equal volume. The **BALANCE** control can compensate to some extent for off-center listening positions, variations in listening room conditions or defects in the original recording.

The three flip-type switches at the left should be in the upper for normal listening. For mono operation flip **MONO** down.

At their center settings the **BASS** and **TREBLE** controls do not affect the tone and you will hear "flat" (unaltered) sound. To increase the bass or treble turn the desired control clockwise (toward +); to decrease, turn the controls counter-clockwise (toward -). In this decreased position the tone controls can reduce hiss (high pitched noise) or rumble (low frequency noise). The **LOUDNESS** switch boosts low and high frequencies at its **IN** (up) position. This compensates for the ear's lack of sensitivity to extreme bass and treble at low volumes.

FM

Turn the **SELECTOR** switch to **FM** and adjust the Tuning knob for the desired station. Fine-tune for maximum reading on the **TUNING** meter.

If you're tuned to a stereo FM station, the **STEREO** light will come on.

With the **MONO** switch in its normal **OUT** (up) position, the tuner will automatically switch from mono to stereo when tuned to a stereo station.

AM

Turn the **SELECTOR** switch to **AM** and adjust the Tuning knob for maximum reading on the **TUNING** meter. Position the ferrite core antenna (rear panel) for the best reception.

PHONOGRAPH

Turn the **SELECTOR** switch to **PHONO** and adjust the **VOLUME** and Tone controls.

For the best sound and longest record life, do not track your cartridge below the recommended force. Light tracking may actually cause more distortion than heavy tracking.

TAPE

Playback

Flip **TAPE MONITOR** down (**IN**) and adjust the **VOLUME** and Tone controls. (**TAPE MON** overrides any position of the **SELECTOR** switch.)

NOTE: if you leave **TAPE MON** down (**IN**), you will not be able to hear the Receiver's **FM**, **AM**, **AUX** or **PHONO** function.

Record

Set the **SELECTOR** switch to the desired input and adjust the Receiver's controls for your own enjoyment (**VOLUME**, **BALANCE** and Tone controls do not affect the output to the tape recorder).

When using a three-head tape deck you can listen to the tape while still recording. Just flip **TAPE MONITOR** down (**IN**).

For the best operation of your tape recorder clean the heads frequently with isopropyl alcohol and a cotton swab. For lowest distortion and tape noise use one of the tape head demagnetizers available at your Radio Shack store.

OPERATING INSTRUCTIONS (cont.)

AUX Input

Turn the **SELECTOR** switch to the desired input and adjust **VOLUME**, **BALANCE** and Tone controls. The auxiliary input can be used for any high-level source such as a tape player, a second tuner, TV, ceramic or crystal phono cartridge, ham radio, etc.

HEADPHONE JACK

The **PHONES** jack is "live" at all times. To listen only to the headphones turn **SPEAKERS** switch to "OUT".

OVERLOAD PROTECTION

Your Receiver has built-in, automatic overload protection. If an abnormal load is presented to the speaker terminals, this protective circuit will automatically silence the receiver.

If this happens, turn power off and check all speaker connections; be sure no pieces of wire are touching between speaker terminals and be sure you don't have 4 ohm speakers connected for both **MAIN** and **REMOTE**.

When you are sure everything is OK, apply power once more.

FUSE

If fuse blows, do not replace with higher rating fuse. Use only 2.5A rated fuse.

HINTS FOR BETTER SOUND

Quatravox Speaker Placement

Where you put the speakers is more critical with 4-channel than it is with stereo. So before you settle on one position try several others – either those illustrated or ones dictated by your listening room.

The theoretically ideal position, one speaker in each corner of a room with the listening position in the center, is shown in Figure A. Since this arrangement is inconvenient in many home installations you may want to modify it. Figure B represents the situation in many homes. The listener faces the two front speakers while the rear speakers face each other. Figures C and D produce a different type of sensation. Instead of being surrounded by sound, the two rear speakers create a sense of depth – as if you were sitting in the audience at a live performance. Depending on the size of your room and the dispersion of your rear speakers you may want them to face you or to face each other.

There are almost an infinite number of satisfying speaker locations for Quatravox, so if one of these doesn't suit your needs invent your own.

Speaker Arrangements for Quatravox

● = listener's position ↑ = direction of sound

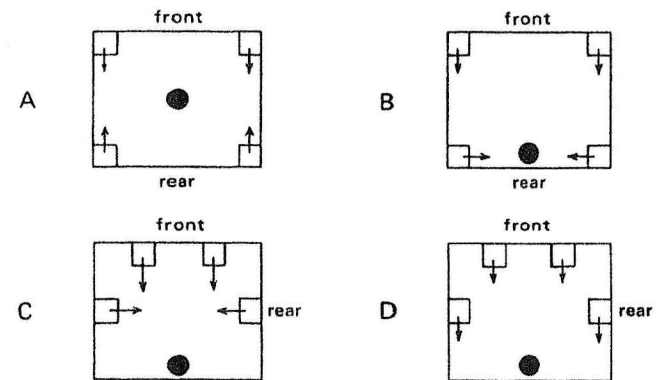

All arrangements based on 6-8' (1.8-2.4 m) minimum front speaker separation.

Antennas

Under most conditions your STA-64's built-in antennas should be adequate for AM and FM reception. If you cannot get adequate reception, try one of the arrangements listed below. Your Radio Shack salesman knows about reception difficulties in your area.

For FM, build the very low-cost folded-dipole (illustrated); or buy one ready-made from Radio Shack (42-2385). Just splice regular 300 ohm lead-in wire as shown. Apply a small amount of solder and heat the twisted ends until it flows evenly over each strand of wire. This antenna can be tacked to the back of a record cabinet or onto a wall — the higher the better.

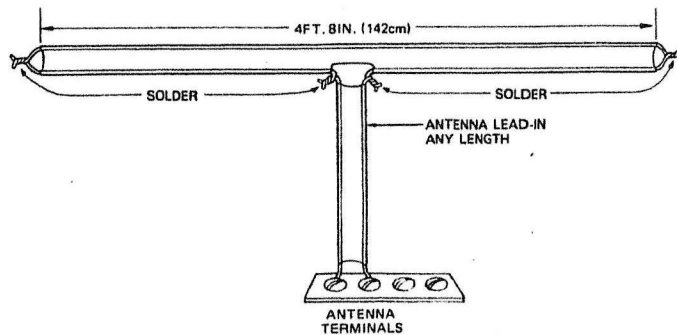

A set of VHF rabbit ears or those made specially for FM reception work well in suburban areas. Some feature electronic "tuning" and amplification circuits for better reception.

An ordinary rooftop VHF TV antenna provides excellent FM reception. An inexpensive "splitter" permits you to use the TV and FM at the same time with very little signal loss.

In extremely weak reception areas, a special outdoor antenna may be the only solution. Such antennas can receive stations up to 175 miles (280 km) away over flat terrain.

Many new homes and apartments have built-in 75 ohm antenna lead-in systems. Your Receiver is designed to be used with either 300 ohm or 75 ohm type antenna systems. See the antenna connection drawings at the right of page 4, the shield portion of the 75 ohm cable must be connected to the GND screw.

For AM, a long piece of wire strung outdoors between two insulators can greatly increase AM long-distance reception. Or, use Radio Shack's 278-758.

NOTE: To protect your receiver use a lightning arrestor on any outdoor antenna.

Connecting an L-Pad

In some cases you may want to vary the volume of the remote, or rear, speakers separately. This can be done very simply and inexpensively with a stereo L-pad, such as Radio Shack Catalog Number 40-979.

In extremely weak reception areas, a special outdoor antenna rear speakers is pre-set for most speaker arrangements. If you have an unusual room set-up or speakers of different types, an L-pad on either front or rear speakers can optimize your system's sound.

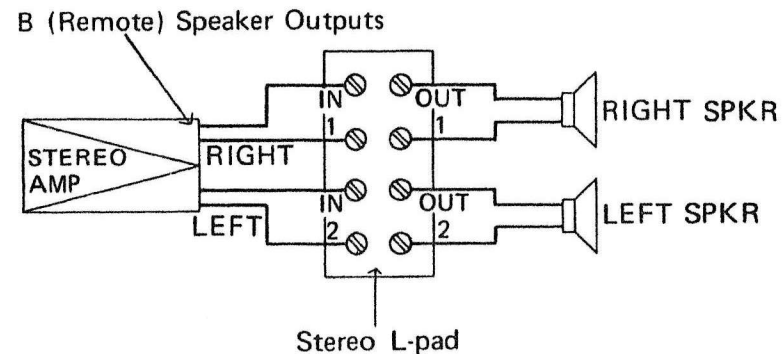

Notes on Tape Recorder Care

A clean demagnetized recorder will give its best performance for many years, while a dirty recorder can mangle or ruin pre-recorded tapes in a very short time.

An inexpensive demagnetizer (degausser) removes residual magnetism from the tape heads. This will insure the lowest possible hiss and distortion and the best possible high frequency response. Always clean and demagnetize your recorder before making critical recordings. Under normal conditions you should demagnetize your recorder after every 10-15 hours of play.

With normal use you should clean the heads and metal tape guides once or twice a month with a special solvent such as Realistic Recorder Cleaner (catalog number 44-1010). Moisten a clean cotton swab with fluid and rub the heads with short circular movements. Then clean oxide deposits from all metal tape guides. There are also a number of cloth cleaning tapes which can be played like a tape for fast, easy cleaning.

You can even use your demagnetizer to help remove oxide particles trapped deep in the head gaps. Place a cleaner-moistened cotton swab over the gap and bring the demagnetizer into contact with it. Move the swab and demagnetizer in short, circular sweeps. Gradually withdraw the demagnetizer and remove the dirty swab.

Yearly preventive maintenance by an authorized technician reduces the possibility of expensive major breakdown and keeps your recorder in peak operating condition.

Headphones

Any stereo system can benefit from a good pair of stereo headphones. They provide the convenience of private listening and many people find the heightened stereo effect of headphones very exciting. Stop by your Radio Shack store to hear some of the headphones we sell — you'll be pleasantly surprised.

The STA-64 will accept any low impedance headphone through its front panel jack. Through its speaker outputs it will drive even the finest electrostatic headsets.

CARING FOR YOUR STA-64

The STA-64's real-wood veneer should be polished from time to time with lemon oil (available from Radio Shack). Waxing produces a glossy finish but it tends to build up and produces a dull coating.

Treat the front panel with care — so you don't scratch it. A window cleaning liquid works well (a small amount on a soft cloth).

VENTILATION — can be important. We merely recommend that you don't place the STA-64 on a surface which would block air circulation — air must be able to circulate freely around the back, under and over the top of the case. Avoid placing on a shag rug, etc. which would block such circulation.

If You Have Problems

We hope you don't; but if you do, here are some suggestions:

1. Check all your cable connections. Make sure all the leads and plugs are secure at **both ends**.
2. Try a different AC outlet if you don't get any indication of power (and be sure you've got the line cord plugged in!).
3. Try interchanging cables and connections on the rear panel — sometimes this will give you a hint of where the problem lies — and may solve the problem for you.
4. If the dial scale lights are on and Meter works — but you have no sound — make sure you didn't leave **TAPE MON** pressed down! If that is not the case — maybe the automatic overload protection circuit has activated. In such a case, turn off **POWER** and check your speaker connections.
 - A. Make sure there is no short across the speaker screw terminals (stray strand of wire touching between terminals or to the metal chassis).
 - B. If you are using more than one pair of speakers, they must be 8 or 16 ohm type (two pair of 4 ohm speakers can overload the amplifier circuit and cause this circuit to activate).
 - C. Let the Receiver cool down for a few minutes and then turn **POWER** back on.
5. If the dial lights don't come on, the fuse may be blown. Check it; replace only with a 2.5 Amp type.

In any case, if none of the above does the job and you still have a problem — help is as close as your local Radio Shack store. Bring your unit in and be ready to describe the symptoms — we will get you back into good stereo sound ASAP!

SCHEMATIC DIAGRAM

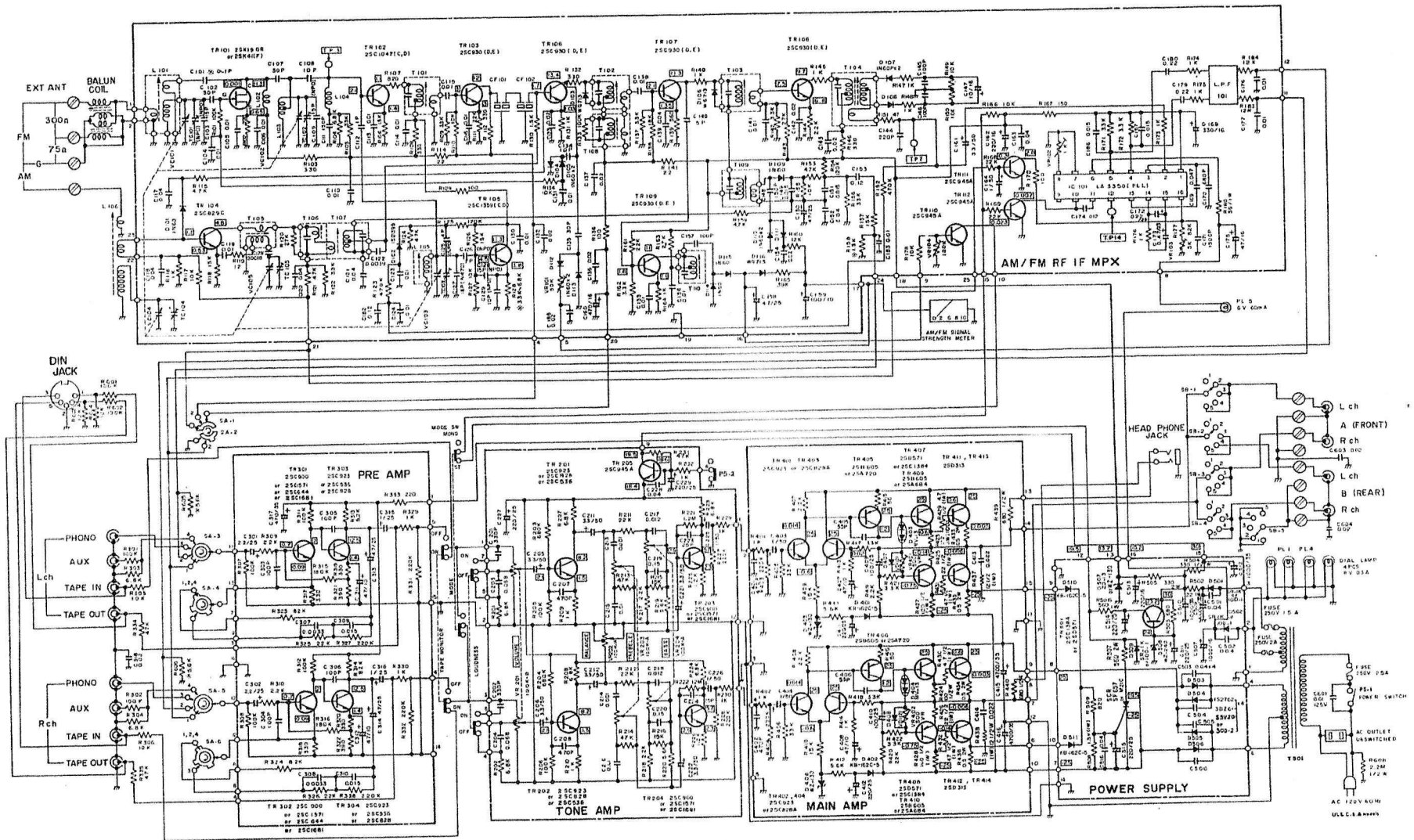

POWER SUPPLY CIRCUIT FOR AUSTRALIAN MODELS

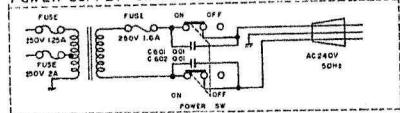

POWER SUPPLY CIRCUIT FOR EUROPEAN MODELS

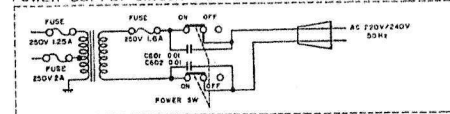

[NOTE]

- (1) SA-1-SA-7 FUNCTION SWITCH 1-AM, 2-FM, 3-PHONO, 4-AUX 4-B, 5-A-H
- (2) SB-1-SB-5 SPEAKER SELECTOR SWITCH 1-OUT, 2-A, 3-QUATRAVOX
- (3) ALL RESISTANCE VALUES ARE INDICATED IN "OHMS" (10³ OHM, M=10³ OHM).
- (4) ALL CAPACITANCE VALUES ARE INDICATED IN "MF" (P=10¹² MF).
- (5) * VALUE MAY VARY FROM UNIT TO UNIT FOR OPTIMUM PERFORMANCE.
- (6) () VALUES IS USED FOR C.S.A. MODELS ONLY.
- (7) PS-1, PS-2 POWER SWITCH

Guaranteed Quality from the builders of the famous ELECTROSTAT-3 TWEETER

NATURAL SOUND *REALISTIC*[®] SPEAKER SYSTEMS

Solo™ Series

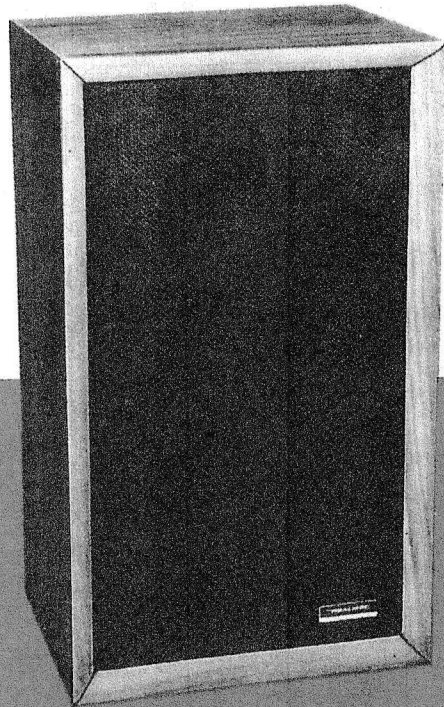

Optimus® Series

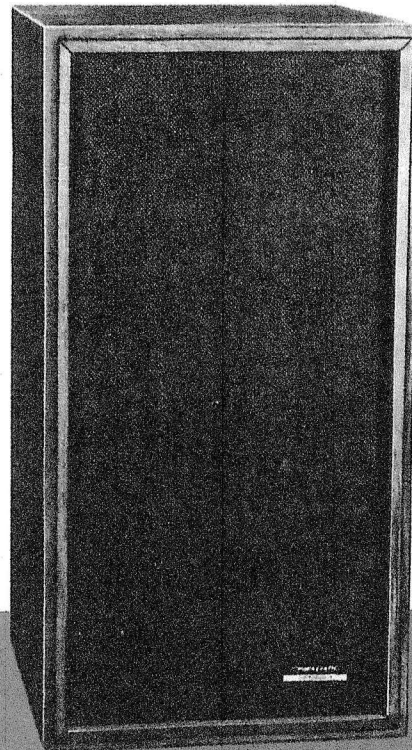

Over 1,000,000 Realistic loudspeakers have been sold in recent years through the nationwide Radio Shack chain. Since the development of its widely acclaimed electrostatic tweeter, Realistic has had an enviable reputation for building good speakers at lower than usual prices. Our Solo, Optimus, Nova, Mach and Minimus Series all have a 5-year warranty. Every speaker is engineered by us, not just "a box with a label." And though speakers are meant to be heard and not seen, every Realistic speaker is born as beautiful as it sounds. Choose from over 20 different models.

Minimus® Series

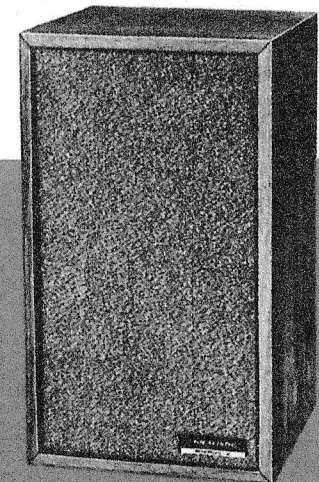

RADIO SHACK  A DIVISION OF TANDY CORPORATION

U.S.A.: FORT WORTH, TEXAS 76102

CANADA: BARRIE, ONTARIO, CANADA L4M 4W5

TANDY CORPORATION

AUSTRALIA

280-316 VICTORIA ROAD
RYDALMERE, N.S.W. 2116

BELGIUM

PARC INDUSTRIEL DE NANINNE
5140 NANINNE

U. K.

BILSTON ROAD
WEDNESBURY, STAFFS WS10 7JN