

AM/FM STEREO RECEIVER
SX-1050
KCU, S

<ART-154-0>

Service Manual



 **PIONEER®**

CONTENTS

1.	SPECIFICATIONS	4
2.	FRONT PANEL FACILITIES	6
3.	CONNECTION DIAGRAM	9
4.	BLOCK DIAGRAM	11
5.	LEVEL DIAGRAM	13
6.	CIRCUIT DESCRIPTIONS	
6.1	AM Tuner	14
6.2	FM Tuner	14
6.3	Equalizer Amplifier	16
6.4	Buffer Amplifier	17
6.5	Tone Control Amplifier	17
6.6	Filter Amplifier	18
6.7	Power Amplifier	19
6.8	Protection Circuit	20
6.9	Surge Current Suppressor Circuit	21
7.	DISASSEMBLY	22
8.	PARTS LOCATIONS	
8.1	Front View 1	25
8.2	Front View 2 (with Panel Removed)	27
8.3	Top View	29
8.4	Bottom View	31
8.5	Rear View	33
9.	DIAL CORD STRINGING	35
10.	ADJUSTMENTS	
10.1	AM Section	37
10.2	FM Section	38
10.3	Power Amplifier Section	42
11.	EXPLODED VIEWS	44
12.	SCHEMATIC DIAGRAMS, P.C. BOARD PATTERNS AND PARTS LIST	
12.1	Schematic Diagram and Miscellaneous Parts	54
12.2	Tuner Assembly (AWE-067)	59
12.3	Equalizer Amplifier Assembly (AWF-020)	66
12.4	Function Switch Assembly (AWS-094)	69
12.5	MIC Jack Assembly (AWX-097)	71
12.6	Flat Amplifier Assembly (AWG-040)	72

12.7 5P Connector Assembly (AWX-062) 76

12.8 Control Amplifier Assembly (AWG-041) 77

12.9 De-emphasis Switch Assembly (AWS-099) 80

12.10 Filter Amplifier Assembly (AWM-089) 81

12.11 Power Amplifier Assembly (AWH-047) 84

12.12 Protection Circuit Assembly (AWM-090) 89

12.13 Speaker Switch Assembly (AWS-095) 92

12.14 Power Supply Circuit Assembly-A (AWR-103) 94

12.15 Surge Current Suppressor Assembly (AWX-098) 97

12.16 Power Supply Circuit Assembly-B (AWR-104) 98

13. PACKING 101

14. PARTS LIST OF EXPLODED VIEWS 102

15. ADDITIONAL INFORMATION (SX-1050/s) 104

MODEL SX-1050 COMES IN TWO VERSIONS DISTINGUISHED AS FOLLOWS:

Type	Voltage	Remarks
KCU	120V only	CSA (Canada) and UL (U.S.A) approved with de-emphasis selector switch (25 μ s/75 μ s)
S	110V, 120V, 220V and 240V (Switchable)	General export model with de-emphasis selector switch (25 μ s/50 μ s/75 μ s)

1. SPECIFICATIONS

Semiconductors

FETs	4
ICs	5
Transistors	79
Diodes	49

Power Amplifier Section

Continuous Power Output

from 20 Hertz to 20,000 Hertz	
(Both channels driven)	120 watts per channel (8 ohms)
	170 watts per channel (4 ohms)

Total Harmonic Distortion (20 Hertz to 20,000 Hertz, from AUX)

Continuous Rated Power Output	No more than 0.1%
60 watts per channel power	
output, 8 ohms	No more than 0.05%
1 watt per channel power	
output, 8 ohms	No more than 0.06%

Intermodulation Distortion (50 Hertz : 7,000 Hertz = 4 : 1, from AUX)

Continuous Rated Power Output	No more than 0.1%
60 watts per channel power	
output, 8 ohms	No more than 0.05%
1 watt per channel power	
output, 8 ohms	No more than 0.06%

Frequency Response

7Hz to 90,000Hz ± 1 dB

Input Sensitivity/Impedance

POWER AMP IN 1 V/50k ohms

Output

Speaker A, B, C, A+B, B+C, A+C
Headphone Low Impedance

Damping Factor

(20Hz to 20,000Hz, 8 ohms) 25

Hum and Noise (IHF, short-circuited, A Network) 100dB

Preamplifier Section

Input Sensitivity/Impedance

PHONO 1	2.5mV/50k ohms
PHONO 2	2.5mV/50k ohms
MIC	6.5mV/50k ohms
AUX	150mV/50k ohms
TAPE PLAY 1	150mV/50k ohms
TAPE PLAY 2	150mV/50k ohms
TAPE PLAY 2 (DIN connector)	150mV/50k ohms

PHONO Overload Level (T.H.D. 0.1%)

PHONO 1	300mV (1kHz)
PHONO 2	300mV (1kHz)

Output Level/Impedance

TAPE REC 1	150mV
TAPE REC 2	150mV
TAPE REC 2 (DIN connector)	30mV/80k ohms

PRE OUT 1V/1k ohms

Total Harmonic Distortion

(20Hz to 20,000Hz, 1V output) No more than 0.05%

Frequency Response

PHONO (RIAA equalization) 30Hz to 15,000Hz ± 0.2 dB
AUX, TAPE PLAY 10Hz to 50,000Hz ± 1 dB

Tone Control

BASS	MAIN	± 10 dB (100Hz)
	SUB	± 5 dB (50Hz)
TREBLE	MAIN	± 10 dB (10kHz)
	SUB	± 5 dB (20kHz)

Filter

LOW	30Hz (12dB/oct.)
HIGH	8kHz (12dB/oct.)

Loudness Contour (Volume control set

at -40dB position) +6dB (100Hz), +3dB (10kHz)

Hum and Noise (IHF, short-circuited, A Network, rated power)

PHONO	75dB
AUX, TAPE PLAY	90dB

Muting -20dB

FM Section

Usable Sensitivity MONO 10.3dBf (3.6 μ V/300 Ω)
STEREO 15.7dBf (6.7 μ V/300 Ω)

Usable Sensitivity (IHF '58) 1.8 μ V
50dB Quieting Sensitivity

MONO 14.5dBf (5.8 μ V/300 Ω)
STEREO 36.0dBf (69 μ V/300 Ω)

Signal to Noise Ratio at 65dBf MONO 78dB
STEREO 73dB

Distortion at 65dBf 100Hz MONO 0.1%
STEREO 0.25%

1kHz MONO 0.1%
STEREO 0.25%

6kHz MONO 0.4%
STEREO 0.4%

Frequency Response 30Hz to 15,000Hz ± 1.3 dB

Capture Ratio 1.0dB

Alternate Channel Selectivity 80dB

Spurious Response Ratio 100dB

Image Response Ratio 85dB

IF Response Ratio 100dB

AM Suppression Ratio 55dB

Muting Threshold 11dBf (3.9 μ V/300 Ω)

Stereo Separation 45dB (1kHz), 30dB (30Hz ~ 15kHz)

Subcarrier Product Ratio 73dB

SCA Rejection Ratio 73dB

Antenna Input 300 ohms balanced
75 ohms unbalanced

AM Section

Sensitivity (IHF, Ferrite antenna) 300 μ V/m
(IHF, Ext. antenna) 15 μ V
Selectivity 40dB
Signal to Noise Ratio 55dB
Image Response Ratio 65dB
IF Response Ratio 85dB
Antenna Built-in Ferrite Loopstick Antenna

Miscellaneous

Power Requirements 120V 60Hz
Power Consumption 490W (UL)
870W (max.)
Dimensions 526.6(W)x173(H)x453.5(D) mm
20-3/4(W)x6-13/16(H)x17-7/8(D) in
Weight 23.4kg (51 lb 8 oz)

Furnished Parts

FM T-type Antenna 1
Operating Instructions 1
Hex. Wrench 1

NOTE:

Specifications and the design subject to possible modification without notice due to improvements.

2. FRONT PANEL FACILITIES

FUNCTION SELECTOR BUTTONS

To select the program source, push each button as follows:
NOTE: Only one FUNCTION button should be depressed at a time.

AM For AM broadcast reception.

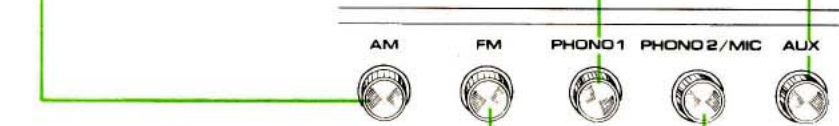

FM For FM broadcast reception. The STEREO indicator lights up when the broadcast is in stereo.

PHONO 1 To operate a turntable connected to the PHONO 1 input jacks.

AUX For listening to an audio component (cartridge tape player, TV sound tuner, etc.) connected to the AUX input jacks.

PHONO 2/MIC As above for PHONO 2 jacks, or for reproduction through microphones connected to the MIC jacks on the front panel. Note, when the microphones are plugged in the turntable connected to the PHONO 2 jacks cannot be used.

TAPE DUPLICATE SWITCH

Set this switch in the ON (down) position to duplicate or edit a recorded tape using two tape decks.



TAPE MONITOR (1, 2) SWITCHES

1 With a tape deck connected to the TAPE 1 jacks (REC and PLAY), either playback or monitoring of a recording in progress are possible.

2 Same as in 1 above, with a tape deck connected to the TAPE 2 jacks (REC and PLAY).

For normal use, leave in the OFF (up) position.

ADAPTOR SWITCH

When employing adaptor components, such as a graphic equalizer adaptor, RG processor, or Dolby NR adaptor, depress this ADAPTOR switch to ON.

Precise volume control

The extremely high power output of the SX-1050 can be finely controlled by combining the calibrated VOLUME control and the MUTING switch. The MUTING switch can also be used to briefly lower the volume when changing records or tapes.

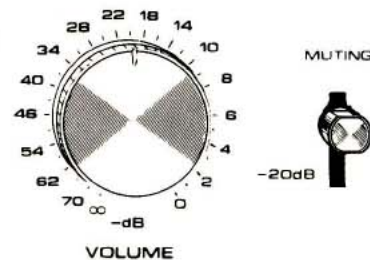

FRONT PANEL FACILITIES

SPEAKER BUTTONS

Three sets of speaker terminals, A, B, and C, are provided on the rear panel, and the required speaker systems can be selected by depressing the SPEAKERS buttons as follows:

- A Speaker systems A operate
- B Speaker systems B operate
- C Speaker systems C operate

NOTES:

1. When any two buttons (A+B, B+C, C+A) are depressed simultaneously, the corresponding pairs of speaker systems will come into operation. However, it is not possible to operate all three speaker systems at the same time, even though all the buttons are depressed.
2. For private listening through headphones, return all the SPEAKERS buttons to the OFF (undepressed) position.

PHONES OUTPUT JACK

Accepts stereo headphones.

POWER SWITCH

After turning this switch ON there is a delay of some 3 to 6 seconds, during which time the protection circuit operates to eliminate unpleasant noise.

TWIN BASS CONTROLS

Adjust low frequency tone.

- 100Hz: Adjusts frequency band below 400Hz. Control effectiveness at 100Hz is $\pm 10\text{dB}$.
- 50Hz: Provides additional control for the frequency band below 200Hz. Control effectiveness at 50Hz is $\pm 5\text{dB}$.

TONE SWITCH

In the OFF (up) position the BASS and TREBLE controls are bypassed, the amplifier section to operate with a flat frequency response regardless of the tone control settings.

FM TUNING METER

With the SIGNAL meter needle deflected to the right, make fine adjustment by centering the FM TUNING meter needle (indicating optimum reception).

SIGNAL METER

For AM and FM station tuning.

AM tuning: Tune for maximum deflection of the SIGNAL meter needle to the right.

FM tuning: Both the SIGNAL and FM TUNING meters work together (see FM TUNING METER).

FM STEREO INDICATOR

SPEAKER SYSTEM INDICATORS

TUNING KNOB

Select the station and tune for optimum reception by observing the SIGNAL meter for AM stations, and both SIGNAL and TUNING meters for FM stations.

FM MUTING BUTTON

Leave this button undepressed (in the ON position) to suppress unpleasant interstation noise while tuning between stations. Low-strength signals may also be suppressed by this function, so to pick up a weak station depress this button to the OFF position.

MIC JACKS

Accept standard 6 mm ϕ microphone plugs.

AUDIO MUTING SWITCH - 20dB

Depress this switch to attenuate the audio output by 20dB. This convenient feature saves having to disturb the VOLUME control, for example when answering the telephone.

VOLUME CONTROL

Adjusts output level of speakers and headphones. Scale is graduated in dB, and when used in conjunction with the MUTING switch, finer and wider range attenuation can be performed.

LOUDNESS SWITCH

Depress this switch when listening at low volume. The frequency response of the human ear varies according to the listening volume, and the depressed position compensates for hearing response by emphasizing the bass and treble.

MODE SWITCH

For stereo playback, leave this switch undepressed (or depress to release, if already depressed). When depressed for MONO playback, left and right channel stereo signals will be mixed to produce monophonic sound from both speaker systems.

BALANCE CONTROL

Adjusts the balance between the sound volume from the left and right speaker systems or headphones.

PROGRAM SOURCE INDICATORS

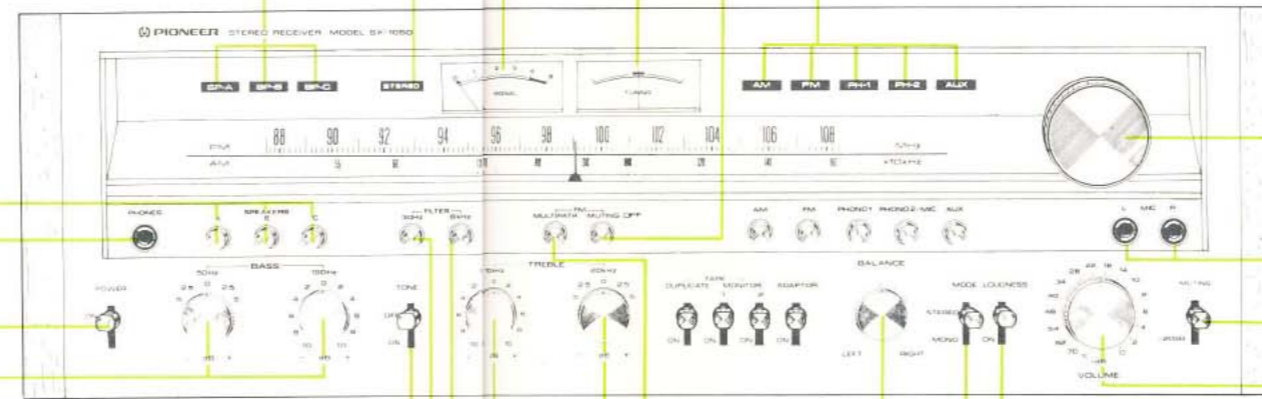

LOW CUT FILTER SWITCH

When low-pitched rumble (from turntable motor or other source) is obtrusive, depress this button to provide 12dB/octave attenuation at frequencies below 30Hz. If no interference is experienced, release this button.

HIGH CUT FILTER SWITCH

When high frequency scratch noise (from worn records or other source) is unpleasant, depress this button to provide 12dB/octave attenuation at frequencies above 8kHz. If there is no interference, release this button.

MULTIPATH SWITCH

When selecting the best position for the FM antenna, depress this button so that multipath noise is heard from the speaker systems. To listen to FM broadcasts, release this button.

TWIN TREBLE CONTROLS

Adjusts high frequency tone.

- 10kHz: Adjusts frequency band above 2.5kHz. Control effectiveness at 10kHz is $\pm 10\text{dB}$.
- 20kHz: Provides additional control for the frequency band above 5kHz. Control effectiveness at 20kHz is $\pm 5\text{dB}$.

4. BLOCK DIAGRAM

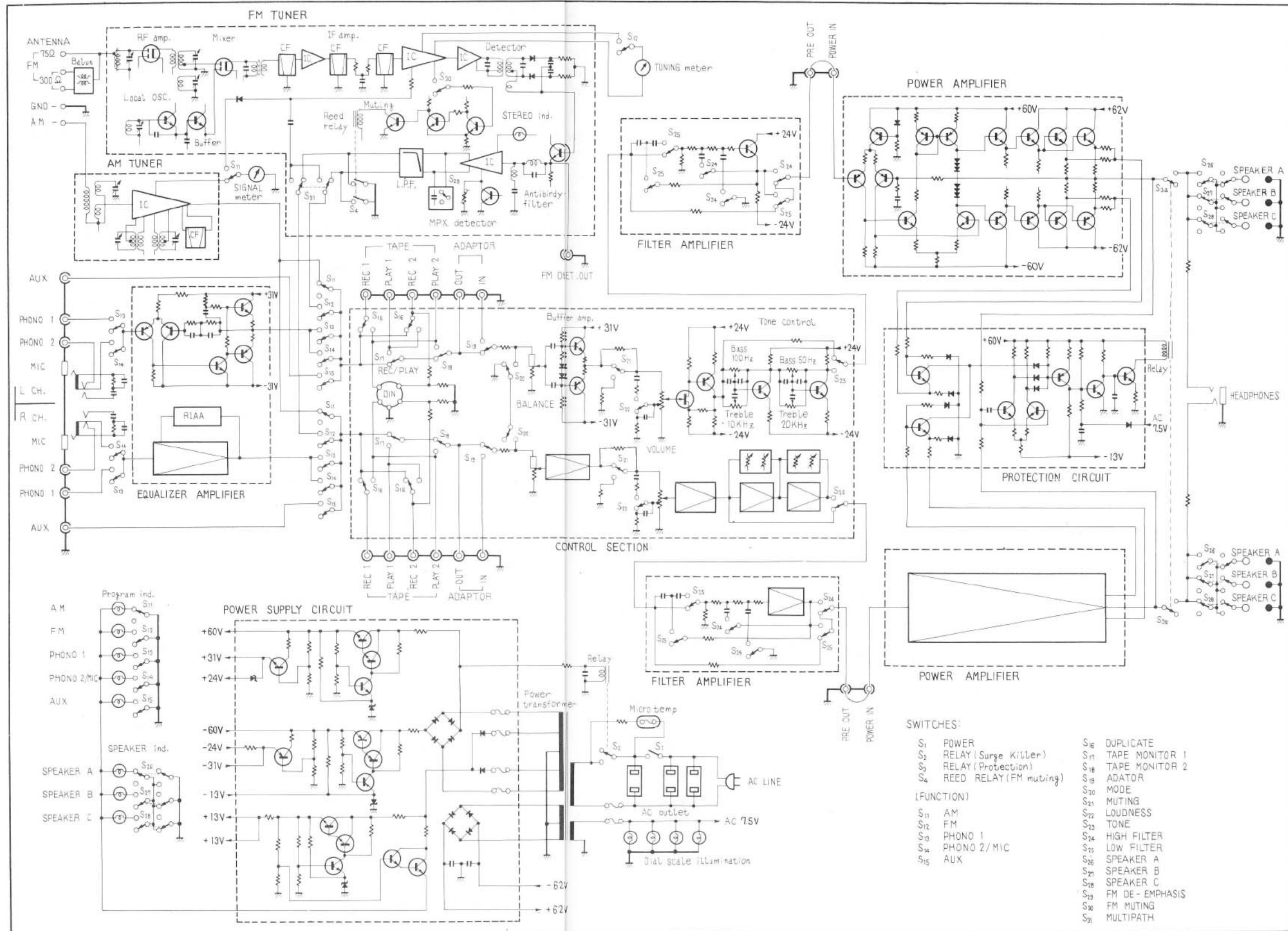

5. LEVEL DIAGRAM

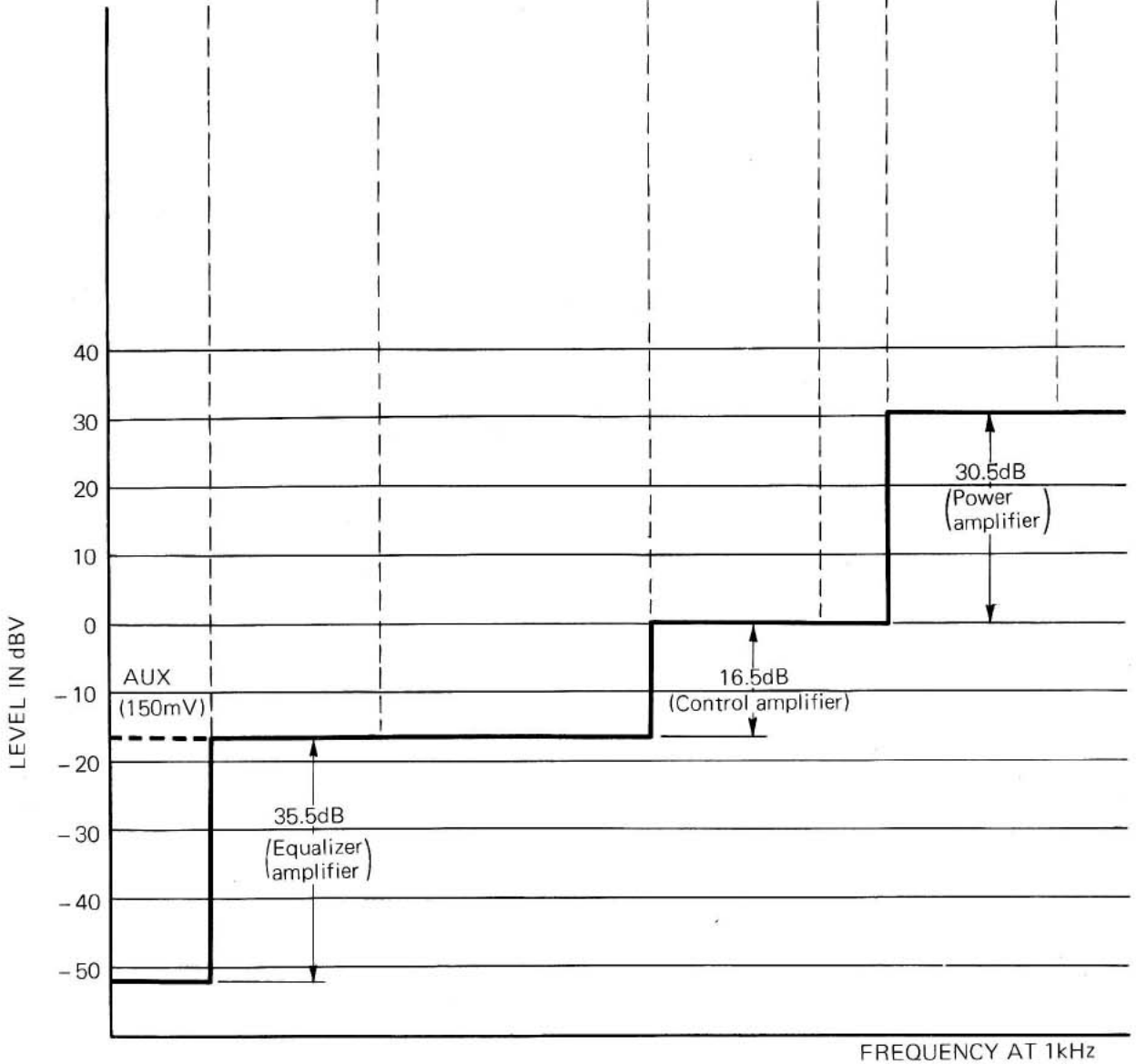
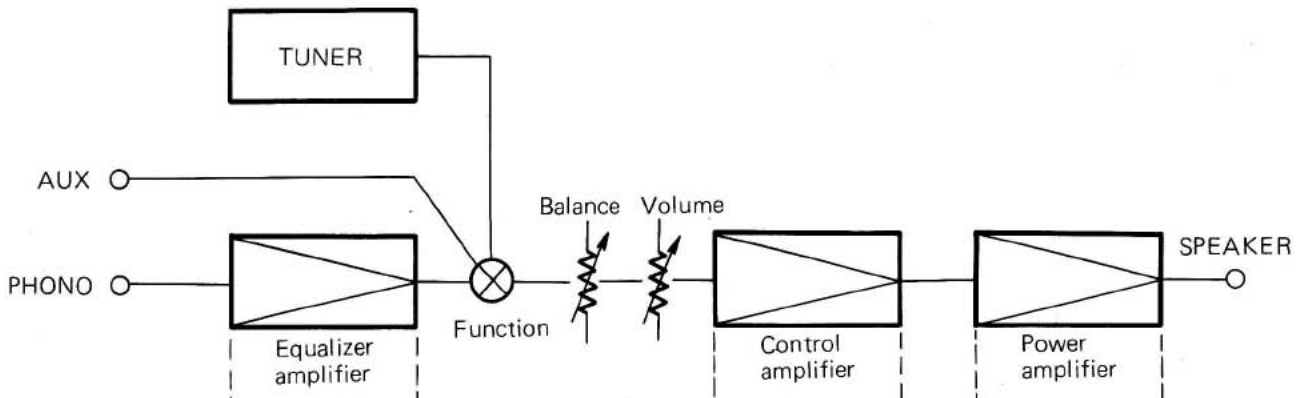

6. CIRCUIT DESCRIPTIONS

6.1 AM TUNER

The AM tuner employs a 3-gang variable capacitor and an IC (HA1138) with 1 stage RF and 2 stage IF amplification. Fig. 1 shows the HA1138 block diagram (see page 55 for circuit).

6.2 FM TUNER

FM Front End

The RF amplifier employs a dual gate MOS FET in a cascade connected circuit (combination common-gate and common-source circuit), allowing stable high gain amplification and low noise to be obtained. A variation of a Clapp oscillator is used in the local oscillator. This circuit features low drift in frequency with respect to fluctuations in power source voltage, ambient temperature changes, and aging. The clean oscillation waveform provides an advantage in terms of low spurious interference.

Waveform distortion is suppressed by inserting a buffer amplifier between the local oscillator and mixer stages. Stable operation with high inputs is also realized.

A dual gate MOS FET cascade amplifier is also employed in the mixer stage. The received signal goes to gate 1 of the FET, while the local oscillator voltage is applied to gate 2. Mutual interference between received signal and local oscillator voltage is reduced by this method, even at high inputs. A low input power from the local oscillator can also be used.

FM IF Amplifier and Detector Circuit

Three dual element ceramic filters, an IC (HA1201) containing a differential amplifier, and an IC (HA1137) containing a 3-stage limiter amplifier compose the FM IF amplifier. Fig. 2 shows the HA1137 block diagram (see circuit diagram on page 55).

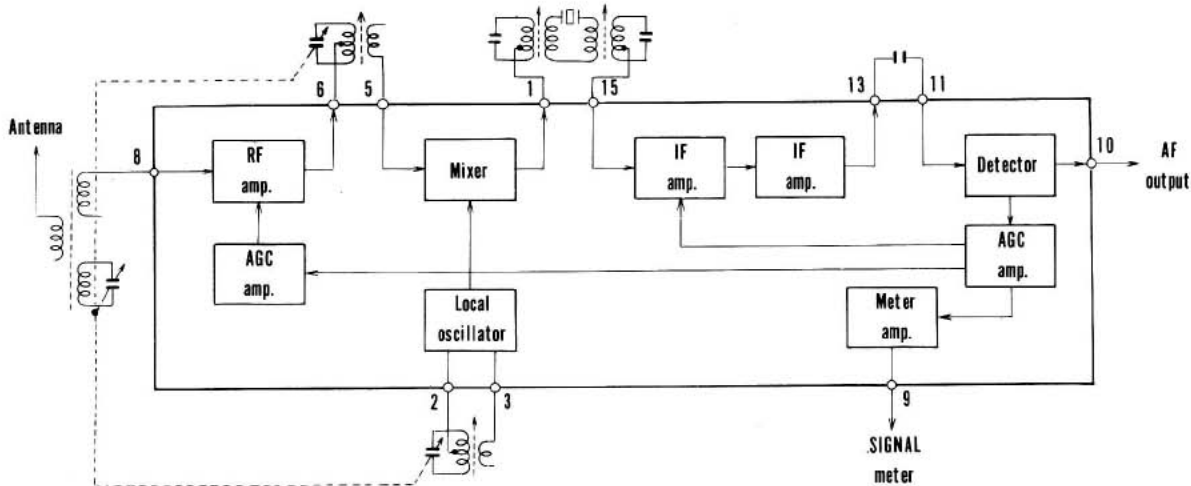

Fig. 1 Block Diagram of HA1138

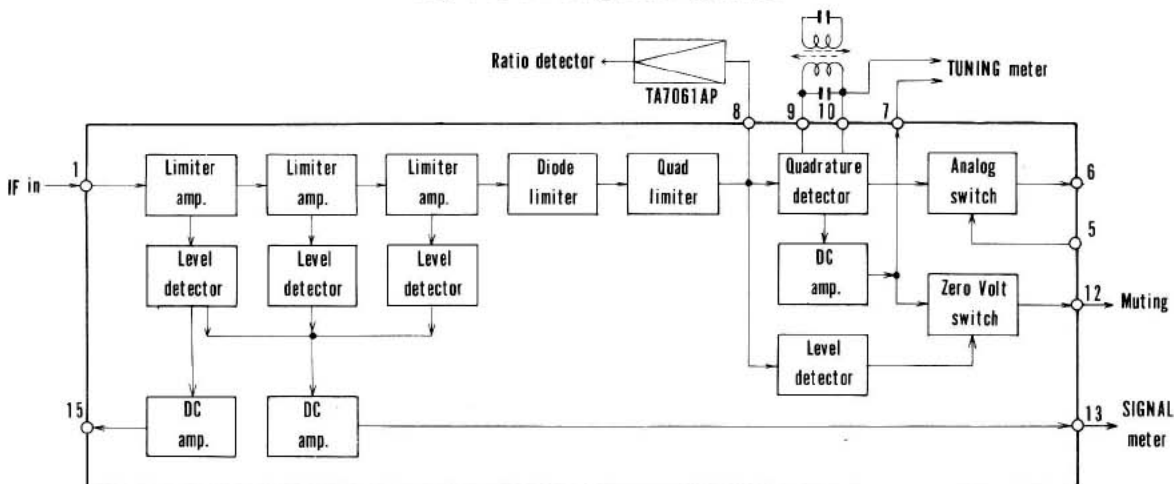

Fig. 2 Block Diagram of HA1137

R14, having an error of no more than 1%, combined with high accuracy polystyrene film capacitors C11 and C12 with a tolerance of 2%, which provide high reliability and fidelity, and are not affected by temperature variations or aging.

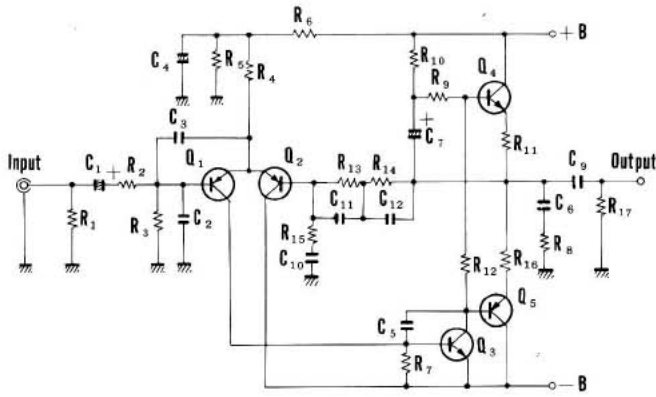

Fig. 6 Circuit Diagram of Equalizer Amplifier

6.4 INPUT BUFFER AMPLIFIER

This is a balanced power supply, pure complementary SEPP buffer amplifier. Although the circuit gain is essentially 0dB, high TAPE MONITOR and AUX jack input impedance can be obtained. The low output impedance permits a low resistance VOLUME control to be employed in the following stage, eliminating observable high frequency deterioration due to VOLUME control position. Since the power supply uses an extremely high $\pm 30V$ push pull arrangement, inclusion of this circuit does not impair dynamic range. The circuit is shown in Fig. 7.

The input signal passes through C1, C2, R3, R4 and is applied to both Q1, Q2.

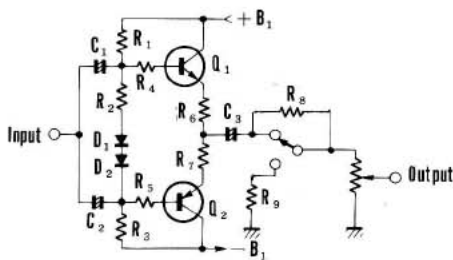

Fig. 7 Input Buffer Amplifier

6.5 TONE CONTROL CIRCUIT

The SX-1050 tone control circuit employs a twin control system consisting of NFB type. An FET and transistor are combined in a two stage direct coupled amplifier, after which two single transistor amplifiers are inserted in series and C-B feedback is applied. Since the feedback circuit possesses selectivity, tone control becomes accomplished. The basic circuit of this section is shown in Fig. 8. The description given here refer to the main tone control circuit. Sub tone control circuit is the same as main tone control description.

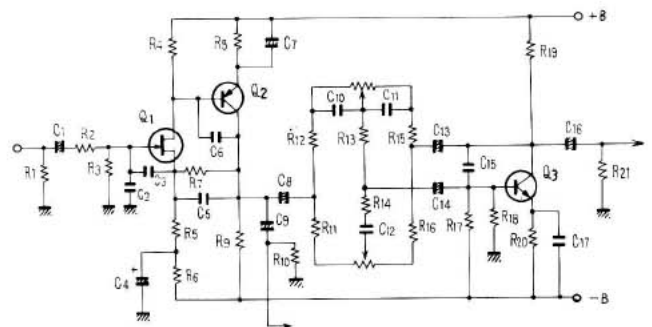

Fig. 8 Tone Control Circuit

Midrange Operation

C10 and C11 reactance is considerably smaller than VR1 at frequencies above midrange, effectively shorting VR1. At frequencies below midrange C12 reactance becomes large and in effect, open. Consequently, the circuit becomes as shown in Fig. 9 with respect to the midrange. In this figure, the circuit constant is not varied at any position of VR1 and VR2 sliders. The NFB amount is therefore fixed and the circuit gain is also fixed without regard to VR1 and VR2 slider positions.

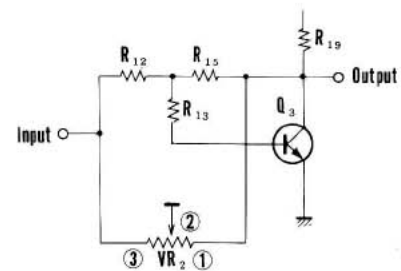

Fig. 9 Equivalent Circuit of Midrange

Low Frequency Operation

The low frequency control circuit is shown in Fig. 10-a, and the equivalent circuit, when boosting low frequency, is shown in Fig. 10-b.

As the parallel impedance of VR1 and C11, in Fig. 10-b, is high at low frequency, the volume of the NFB decreases and the gain in the low frequency range increases.

The equivalent circuit, when cutting out low frequencies, is shown in Fig. 10-c. In this case, the input signal is applied to Q3, through the parallel impedance of VR1 and C10, which is high in the low frequency range and suppresses the lower frequency signals.

The circuit gain at low frequencies can therefore be varied by VR1.

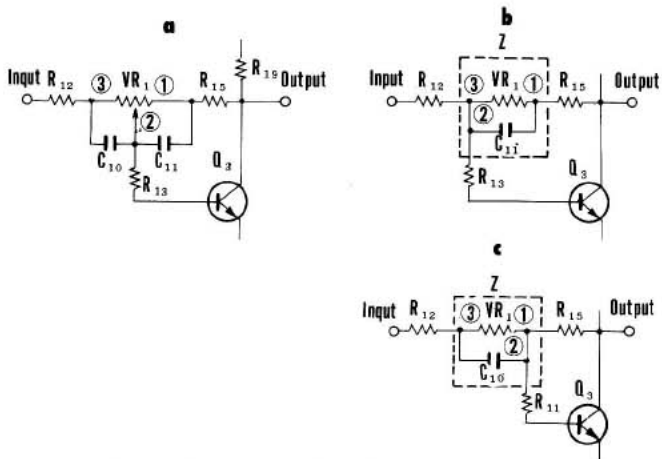

Fig. 10 Equivalent Circuit High Frequency Operation of Bass Boost and Cut

High Frequency Operation

The high frequency control circuit is shown in Fig. 11-a, and the equivalent circuit, when boosting high frequencies, is shown in Fig. 11-b.

In this circuit, the input signal is applied to Q3 through the parallel impedance circuit. This impedance is low in the high frequency range and produces a signal with an enhanced high range. Fig. 11-c shows the equivalent circuit when cutting out high frequencies. As the impedance of R13, R15 and C12 of the circuit becomes low, the level of the NFB increases and the gain of the circuit decreases.

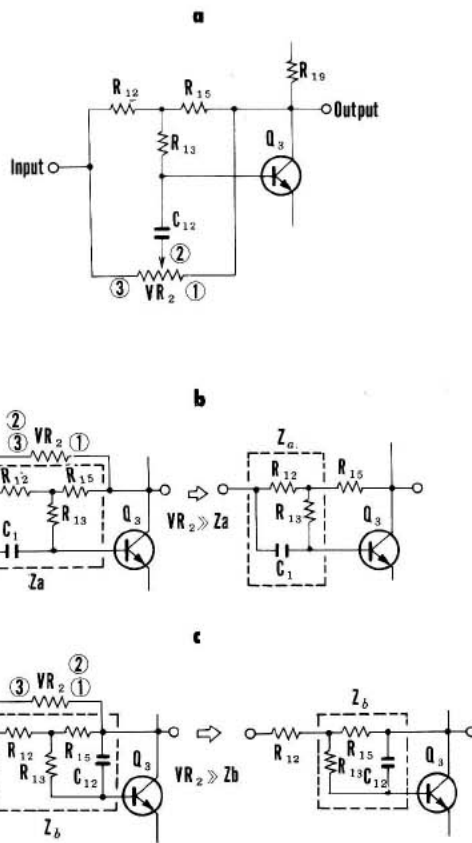

Fig. 11 Equivalent Circuit of Trouble Boost and Cut

6.6 FILTER AMPLIFIER

The circuit shown in Fig. 12 has a steep characteristic of 12dB/oct, and is effective in removing noise. The low cutout filter can be switched to the two positions of 30Hz and OFF. The high cutout filter can be switched to the two positions of OFF and 8kHz.

When both LOW CUT FILTER and HIGH CUT FILTER switches are positioned at OFF, the input signal is bypassed filter circuit and fed to next stage.

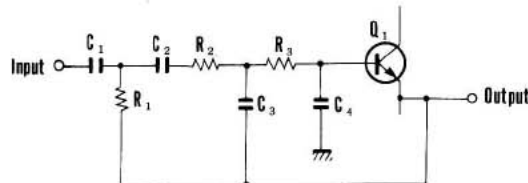

Fig. 12 Circuit Diagram of Filter Amplifier

6.7 POWER AMPLIFIER

The power amplifier of the SX-1050 is a direct coupled, pure complementary parallel push pull circuit, which uses a differential amplifier with constant current circuit, and current mirror circuit, consisting of 15 transistors. The circuit diagram is shown in Fig. 13.

Q1 and Q2 form the differential amplifier. The input signal is applied to Q1 and NFB from the output stage applied to Q2 base. Q1 and Q2 outputs respectively drive Q4 and Q5 in reverse phase. The Q4 output is applied to the current mirror circuit formed by Q6 and Q7. Q5 and Q7 outputs thus become signals of the in phase and perform a pre-driver function.

Fig. 14 shows the equivalent circuit of the current mirror.

Since Q6 in the figure is shorted between base and collector, it becomes equivalent to a diode, and is thus indicated by a diode symbol. The current mirror circuit operates so that current flow (I_1) at R17 & Q6 becomes equivalent to that at R21 & Q7. In other words, point A potential is determined by R17 & Q6 current (I_1). Since this potential is also Q7 base potential, it controls the current flow (I_2) at R21 & Q7. Currents I_1 and I_2 become equal since the value of resistors R17 and R21 are the same, as the characteristics of transistors Q6 and Q7 are.

Q8-Q11 in the following driver stage drive the power transistors by direct coupling. The final stage is a high output design with four power transistors for coupled in parallel. This parallel coupling permits comparatively large current to be employed through each transistor, plus selection of an operating point with good linearity and high gain amplification.

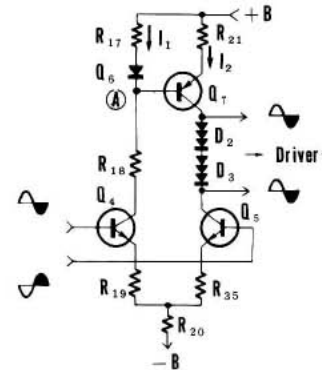

Fig. 14 Current Mirror Circuit

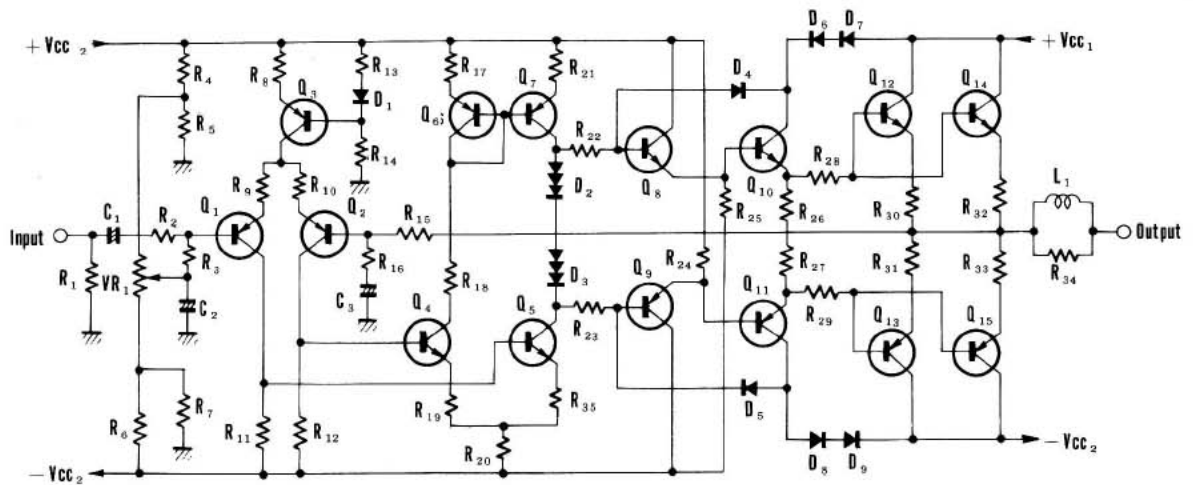

Fig. 13 Circuit Diagram of Power Amplifier

6.8 PROTECTION CIRCUIT

This protection circuit functions to protect the speakers and the power amplifiers from damage due to short-circuit of the load, etc., and performs a muting operation to cut noise and distortion which occur when switching the power on and off. The circuit is shown in Fig. 15, and consists of a bridge type over-current and overload detector, a differential amplifier DC voltage detector, and a power switch ON/OFF detector section.

Relay Driving Circuit

Q4-Q6, in Fig. 15, comprise the relay driving circuit.

In the normal condition reverse bias is applied to the base of Q4, and Q4 is in a off state. When one of the above mentioned detection circuits goes on, current flows through R11, the base potential falls and Q4 is turned on. Consequently Q5 comes on and Q6 goes off. When Q6 goes off, the current of the relay circuit is cut, to release the switch of the output circuit.

When the power switch is turned on, a delay operation occurs in this circuit. R17 and C3, in the base circuit of Q6, are the time constant elements which determine the delay time. When the power switch is turned on, C3 charges to a potential of +60 volts through R17 and R18, and Q6 is kept in the off state during this time. When the power source is switched off, the muting operation of Q5 prevents shock noise. In the normal condition, the potentials of +60 volts and -5.1 volts are applied to Q5 through R14 and R15. The resultant potential at the base of Q5 is -1 volt in the cutout condition. When the power supply is turned off,

of -5.1 volts disappears immediately due to the small time constant of the power circuit. Thus a positive base potential remains, switching Q5 on, which in turn switches off Q6 and hence the relay.

Detection of DC Voltage

This is a differential amplifier consisting of Q2 and Q3, as shown in Fig. 16. The bases of Q2 and Q3 are connected to the center points of the right and the left power amplifiers. When the DC balance of the power stage is lost for some reason, a potential difference is produced in the input signal to the differential amplifier, and the collector currents of Q2 and Q3 are put out of balance. Thus, the relay driving circuit functions, and the relay switch is turned off.

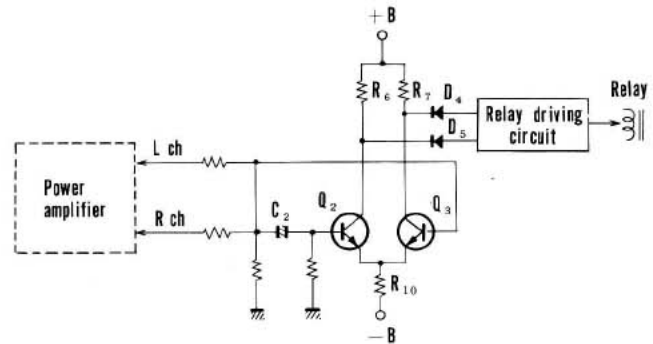

Fig. 16 DC Voltage Detection Circuit

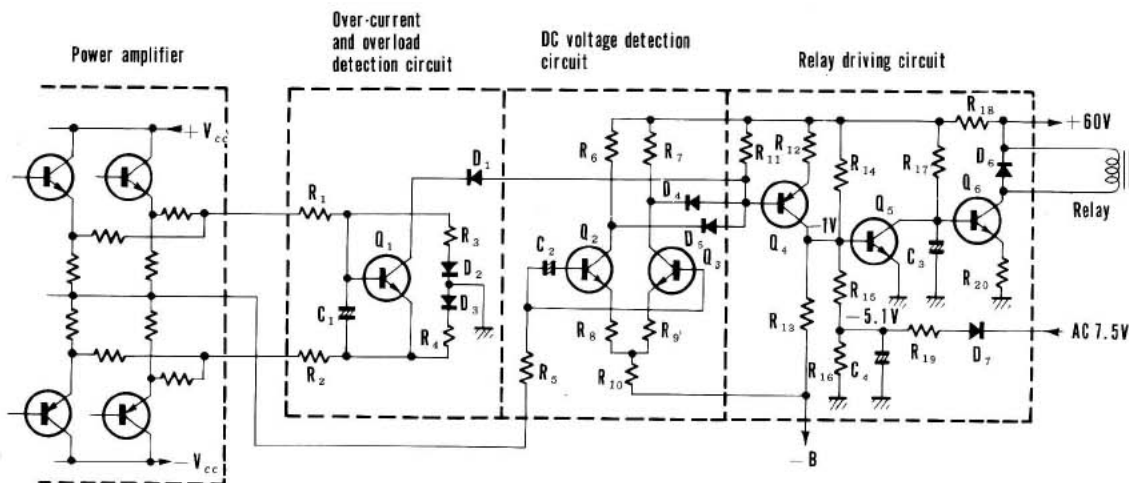

Fig. 15 Protection Circuit

Over-current and Overload Detection

The equivalent circuit of this detector section is shown in Fig. 17, and Fig. 18-a shows the equivalent circuit at the time of a positive half cycle. When this equivalent circuit is overloaded, the balance of the bridge, formed by RE1, R1, R3 and RL, is disturbed, and a potential is produced between b and a in such a direction that Q1 is turned on. When Q1 is turned on, the collector current increases, the relay driving circuit functions and the relay switch of the output circuit is turned off.

After the cause of the overload is removed, the bias of Q1 is reduced and the relay switch turns on to automatically restore normal operation, Fig. 18-b shows the equivalent circuit at the time of a negative half cycle. In this circuit, a potential is produced between b and e as above, and Q1 is turned on.

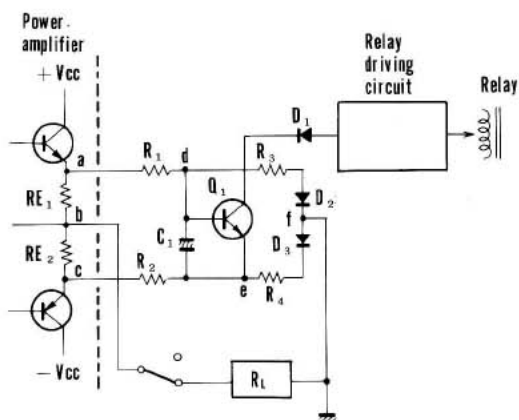

Fig. 17 Over-current and Overload Detection Circuit

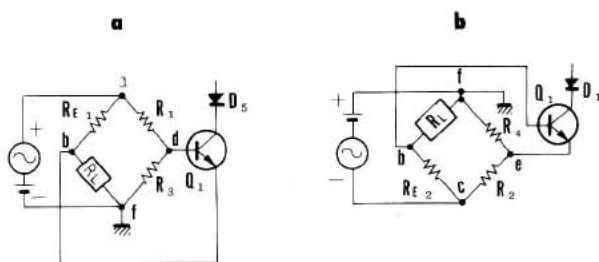

Fig. 18 Equivalent Circuit of Fig. 17

6.9 SURGE CURRENT SUPPRESSOR CIRCUIT

A toroidal core power transformer is employed in the SX-1050, which possesses compactness and a large handling capacity, also exhibits extremely low internal resistance. In combination with the two 22,000 μ F electrolytic capacitors forming the power supply, surge current accompanying power switch operation can reach a maximum of 130 ~ 150A. The power supply can therefore be damaged unless protective measures are taken.

The main sources of surge current generation are power transformer excitation current and power supply electrolytic capacitor charging current.

The surge suppressor circuit is employed in the primary power transformer circuit. This circuit is shown in Fig. 19.

Power transformer excitation current is handled by the relay surge suppressor circuit at the primary side. When the power switch (S1) is turned ON, the relay (S2) drive current flows through R2 and charges C3, therefore it does not flow through the S2 drive coil immediately, and S2 remains OFF. The transformer excitation current flows through temperature fuse and R1 during this interval. After C3 is completely charged, drive current flows in the S2 drive coil switching it ON, and temperature fuse and R1 is shorted.

The delay time is determined by R2 and C3. By employing this circuit, surge current is limited to approximately 60A.

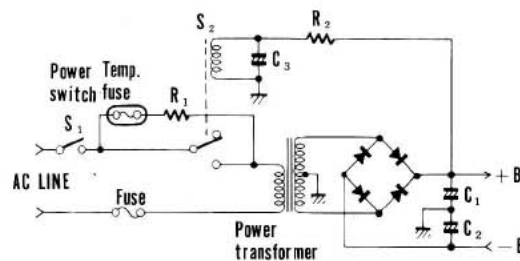

Fig. 19 Surge Current Suppressor Circuit

7. DISASSEMBLY

Top Cover (Fig. 20)

Remove the 2 screws on each side of the top cover.

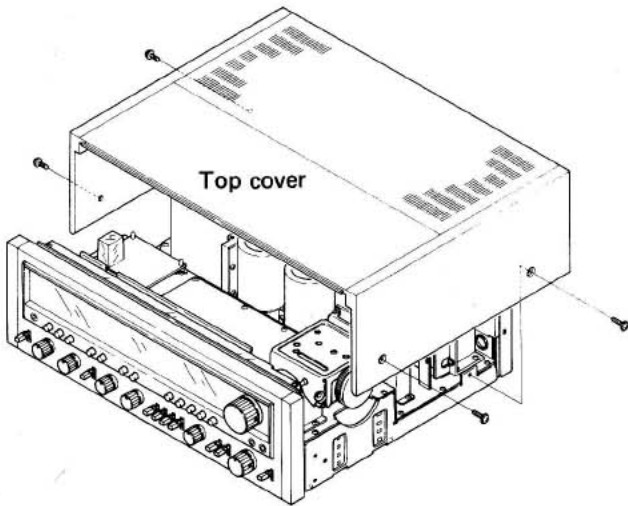

Fig. 20

Bottom Plate (Fig. 21)

Remove the 16 screws to detach the bottom plate.

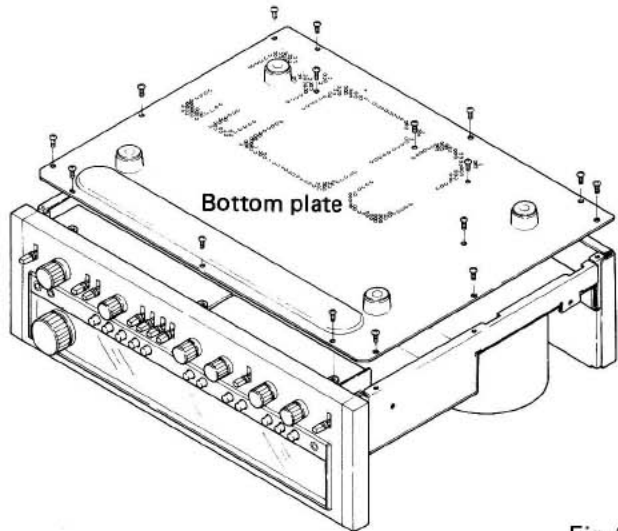

Fig. 21

Front Panel Assembly (Fig. 22)

1. Remove the top cover.
2. Remove the 2 screws (A) from the top edge of the front panel.
3. Loosen the setscrews of TUNING knob and VOLUME knob with a hexagonal wrench.
4. Remove all control knobs by pulling.
5. Remove the 3 nuts (B).

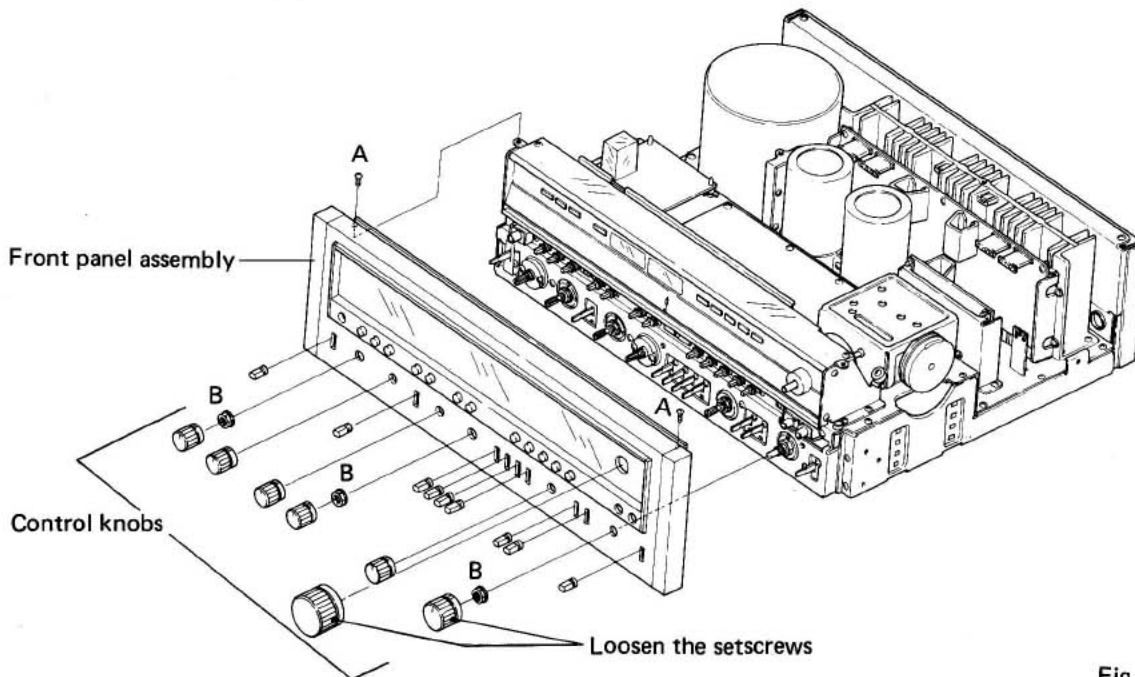

Fig. 22

Tone Amplifier Assembly (Fig. 23)

Remove the 3 screws (C).

Flat Amplifier Assembly (Fig. 23)

Remove the 3 screws (D).

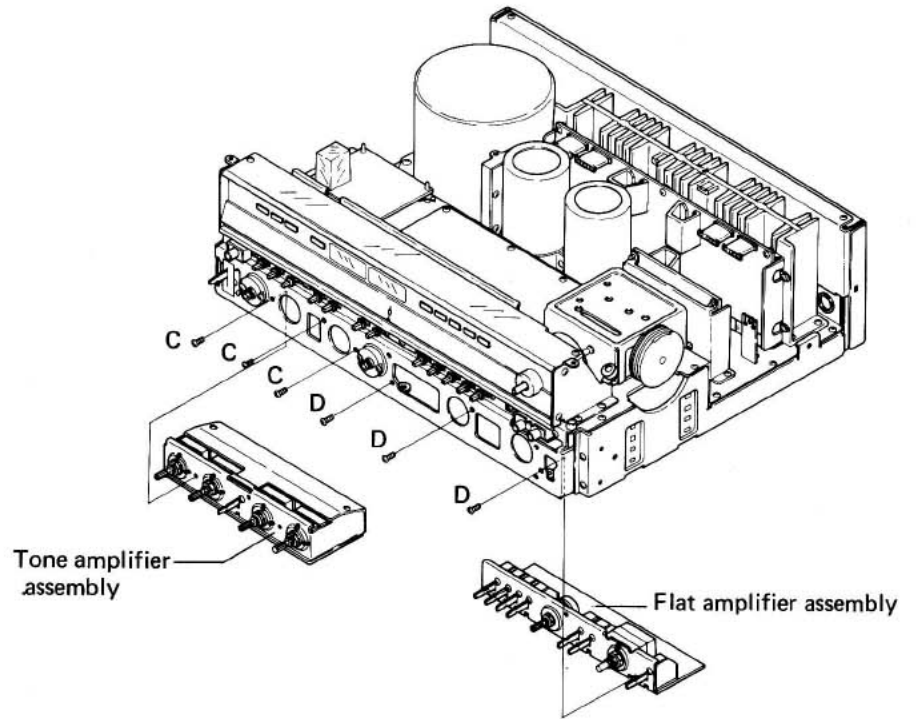

Fig. 23

Speaker Switch Assembly (Fig. 24)

Remove the 4 screws (E).

Filter Amplifier Assembly (Fig. 24)

Remove the 2 screws (F).

Function Switch Assembly (Fig. 24)

Remove the 2 screws (G).

Microphone Jack Assembly (Fig. 24)

Remove the 2 screws (H).

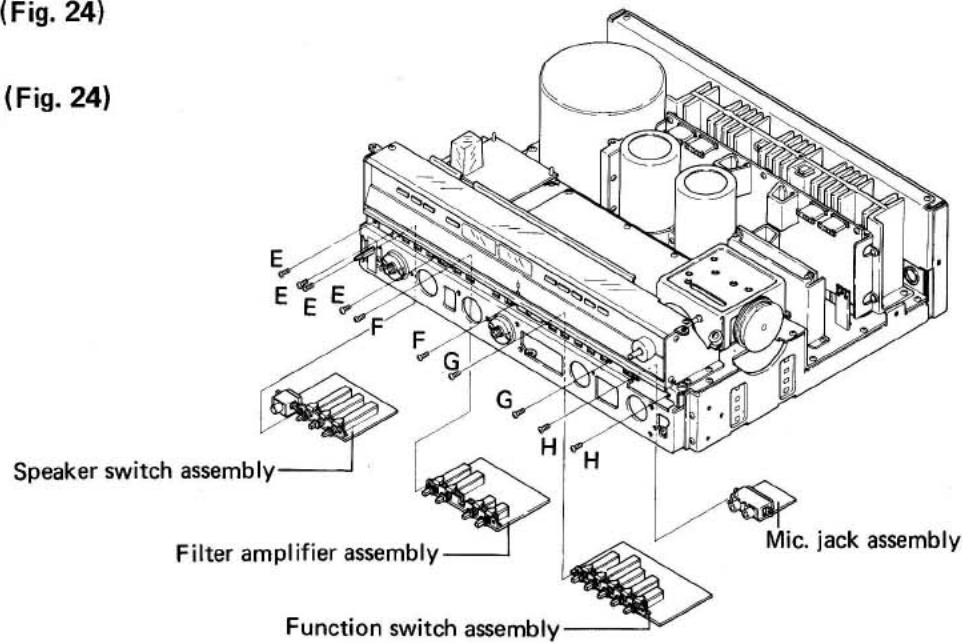

Fig. 24

Dial Panel (Fig. 25)

1. Remove the top cover and front panel.
2. Unscrew the 2 screws (I) which mount the acrylic board. Remove the acrylic board.
3. Unscrew the 3 screws (J) which mount the lamp board assembly on the chassis. Incline the lamp board assembly to the rear.
4. Unscrew the 2 screws (K) mounting the double meter fixing bracket on the chassis.
5. Unscrew the 4 screws (L) mounting the SPEAKER indicator and program indicator fixing brackets on the dial panel.
6. Remove the 3 screws (M) to detach the blind sash.
7. Remove the shaft cover, nut and washer from the tuning shaft assembly. Remove the dial pointer from the dial panel. Take care not to slip off the dial cord when removing the dial pointer and tuning shaft. If the dial cord is slipped off, string it according to "Dial cord stringing" on page 35.
8. Remove the 4 screws (N) to detach the dial panel.

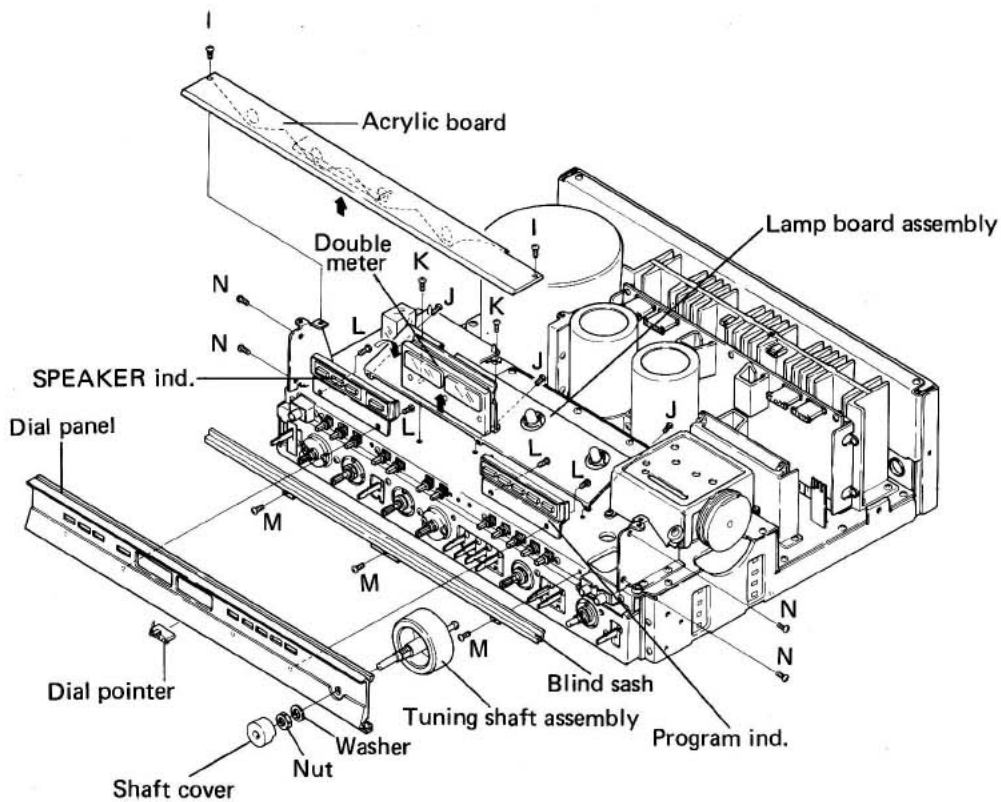
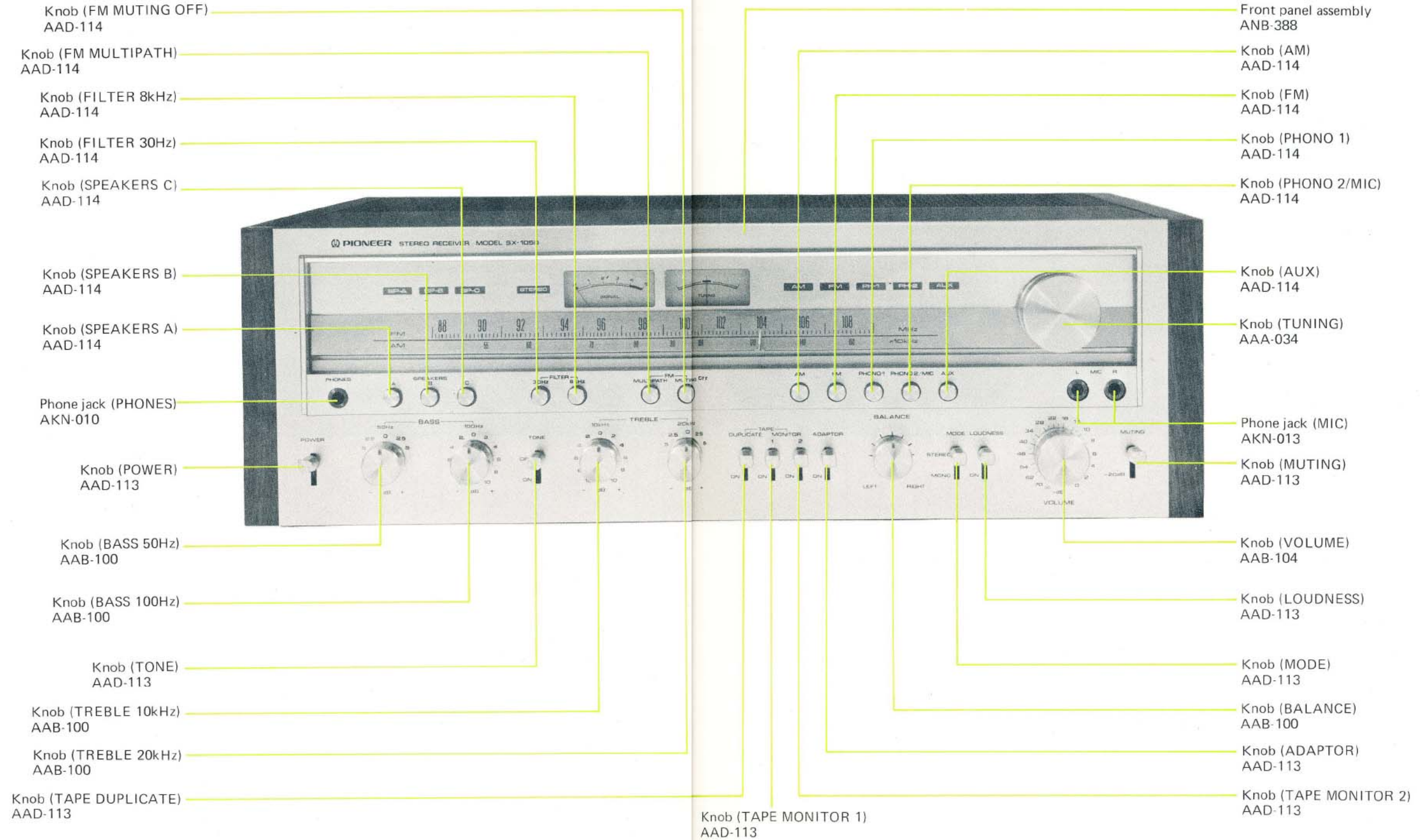

Fig. 25

8. PARTS LOCATIONS

8.1 FRONT VIEW 1



8.2 FRONT VIEW 2 (with Panel Removed)

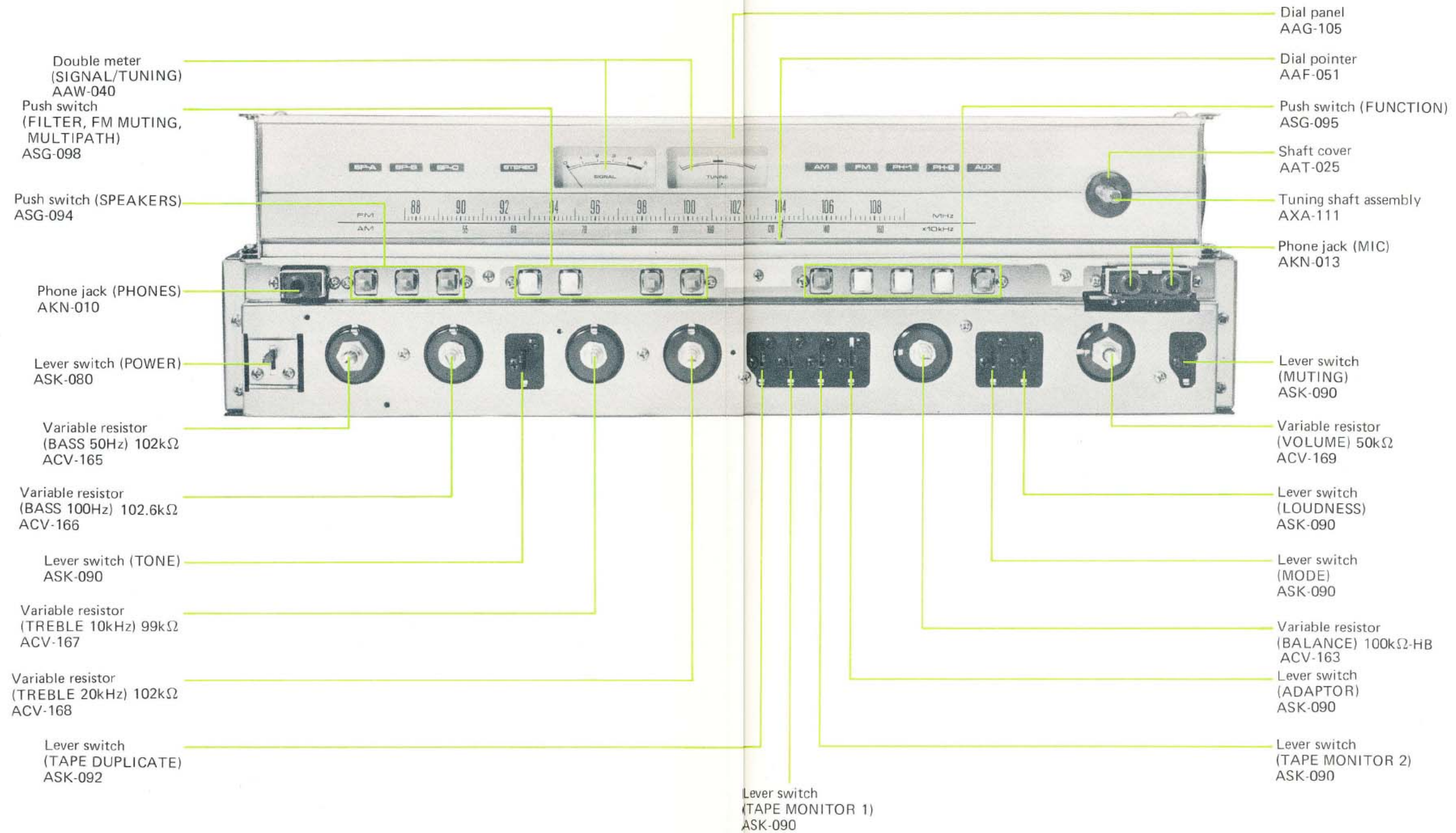

8.3 TOP VIEW

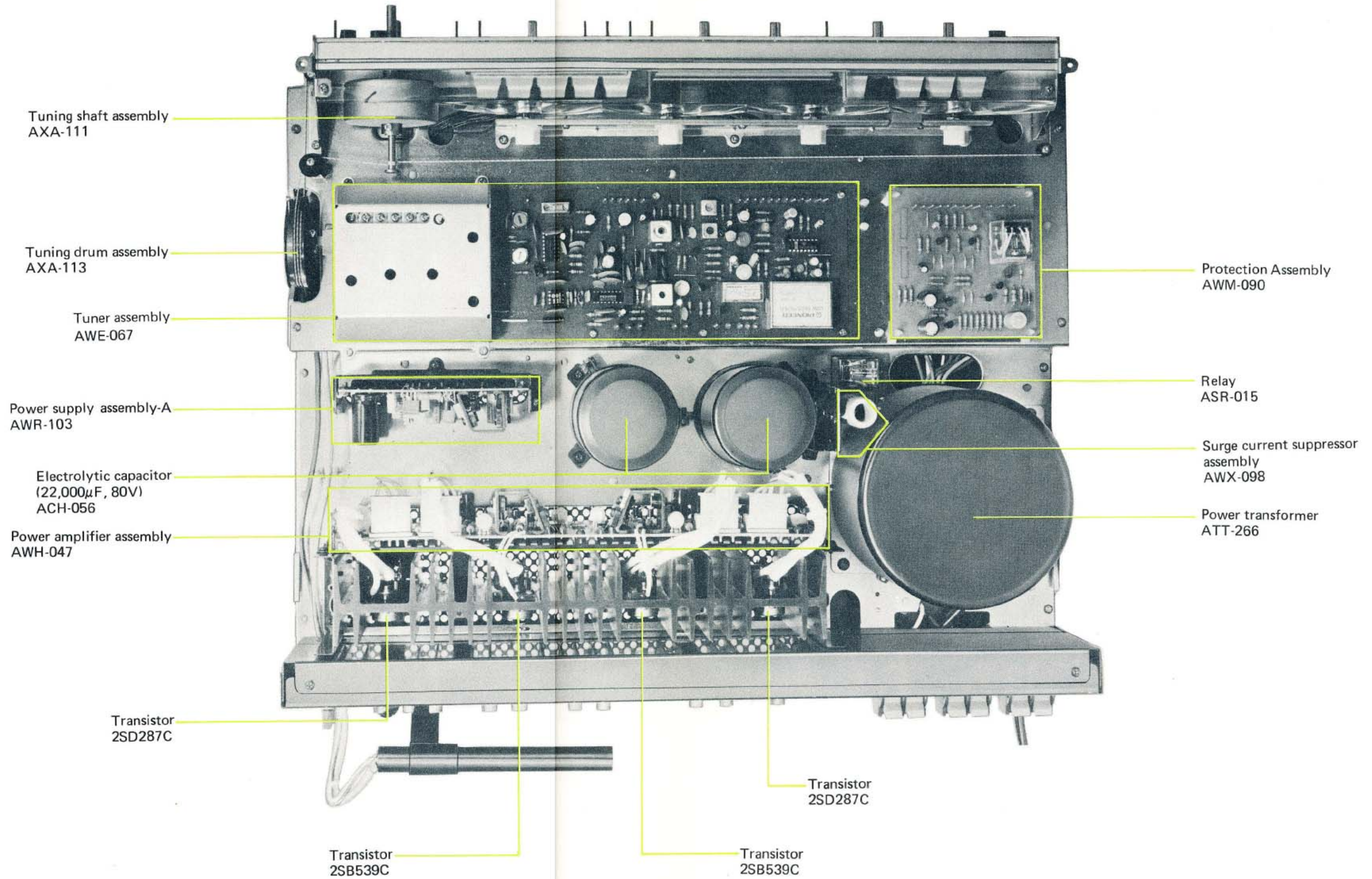

8.4 BOTTOM VIEW

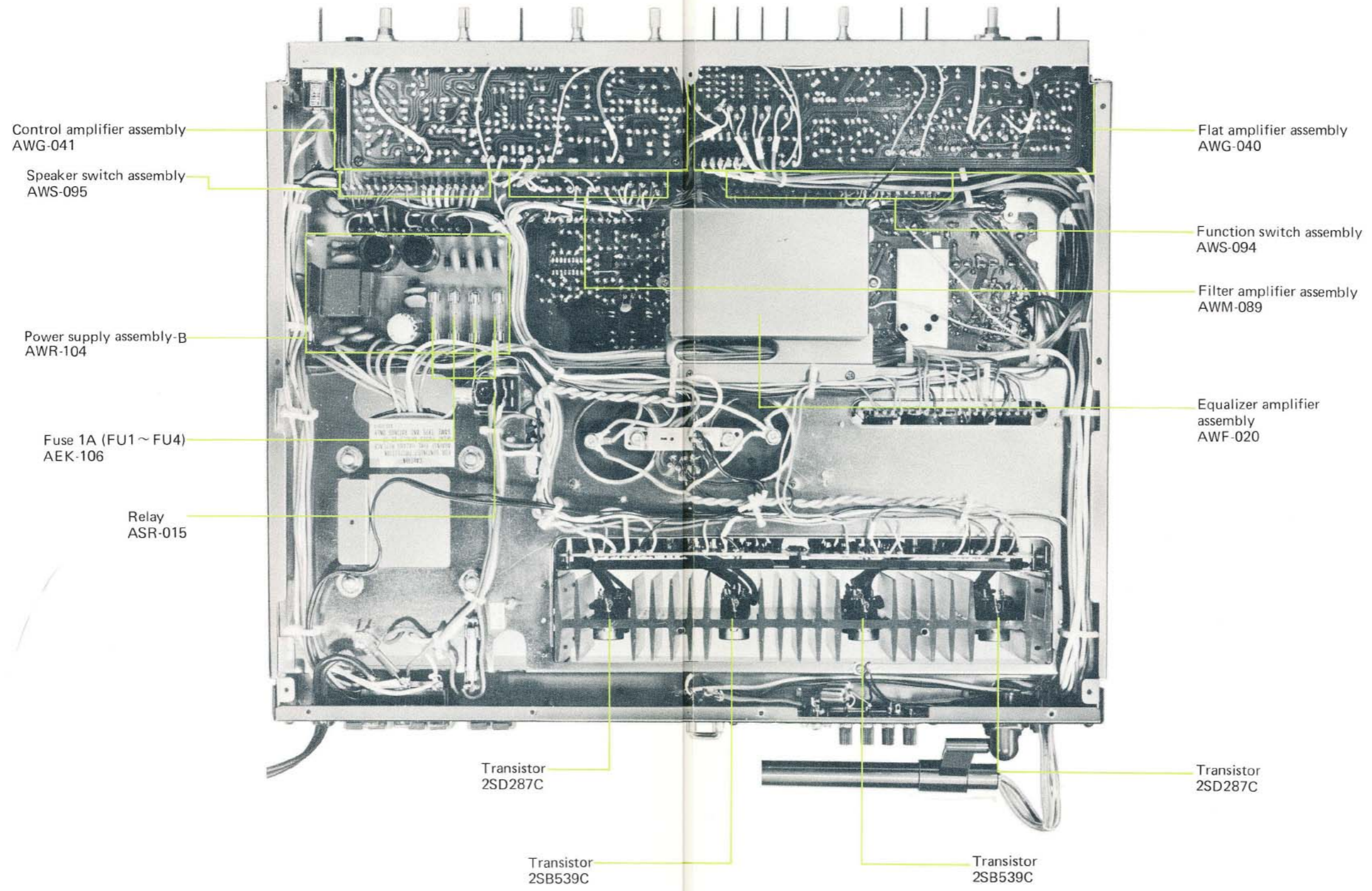

8.5 REAR VIEW

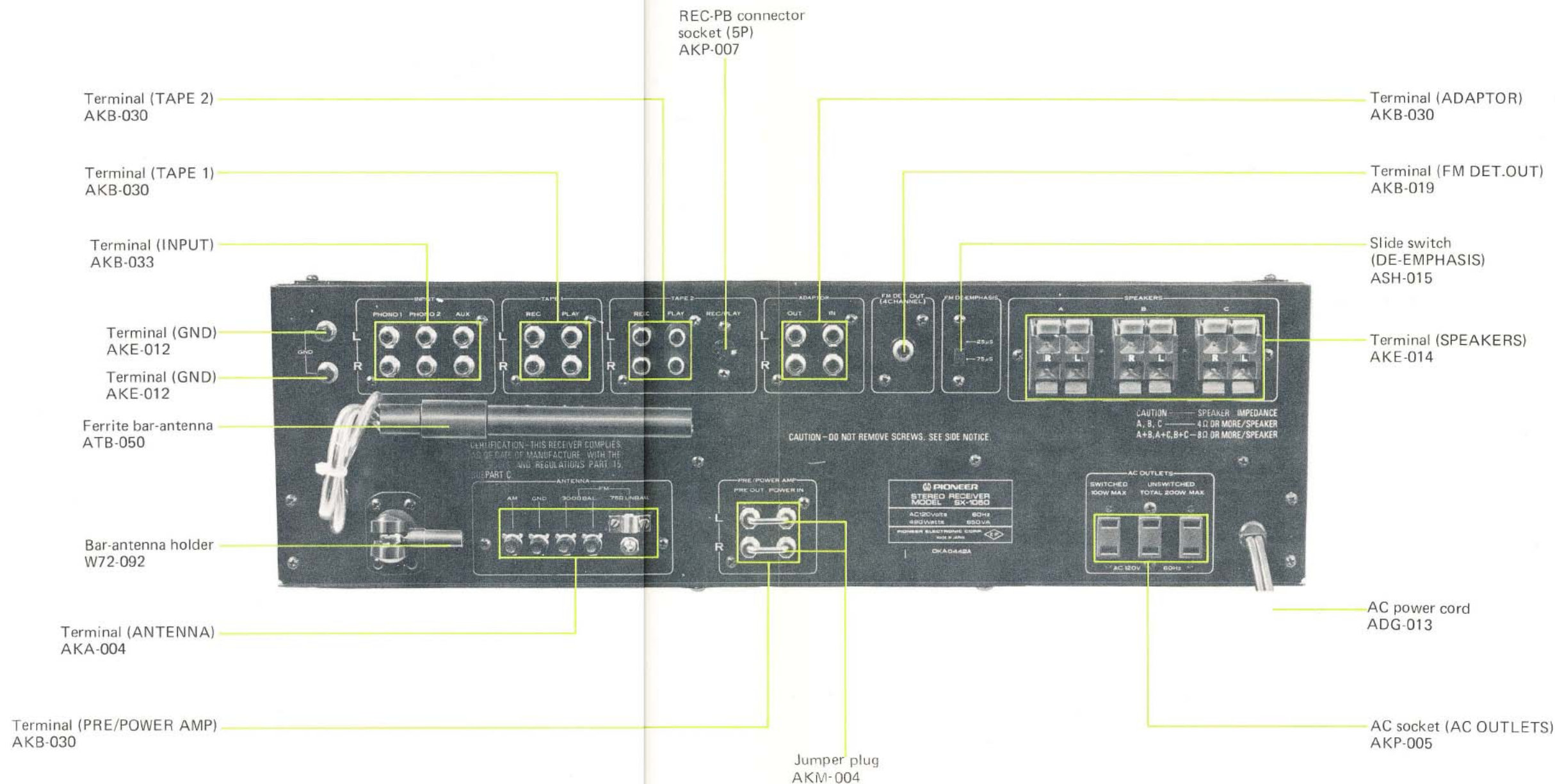

9. DIAL CORD STRINGING

1. Remove the top cover and the front panel. el.
2. Remove the three screws to detach the blind sash (Fig. 26).
3. Turn tuning drum fully clockwise (as viewed from X direction in (Fig. 27).
4. Tie one end of cord to stud on inner section of tuning drum (more easily performed by loosening setscrew and temporarily removing tuning drum from shaft).
5. Route cord through tuning drum cutout, make a half turn around the drum, then route in sequence to pulley A—dial pointer—pulley B—pulley C.
6. Wind cord 3 turns clockwise (as viewed from rear panel) around tuning shaft, then route to pulley D.
7. Wind cord two turns around tuning drum and tie to spring hook so that tension is applied to the cord.
8. Turn TUNING knob and confirm normal cord motion, then trim off excess cord.
9. With tuning drum at step 1 setting, restrain cord from moving and slip dial pointer on cord. Align it with the starting point (extreme left end of frequency scale).

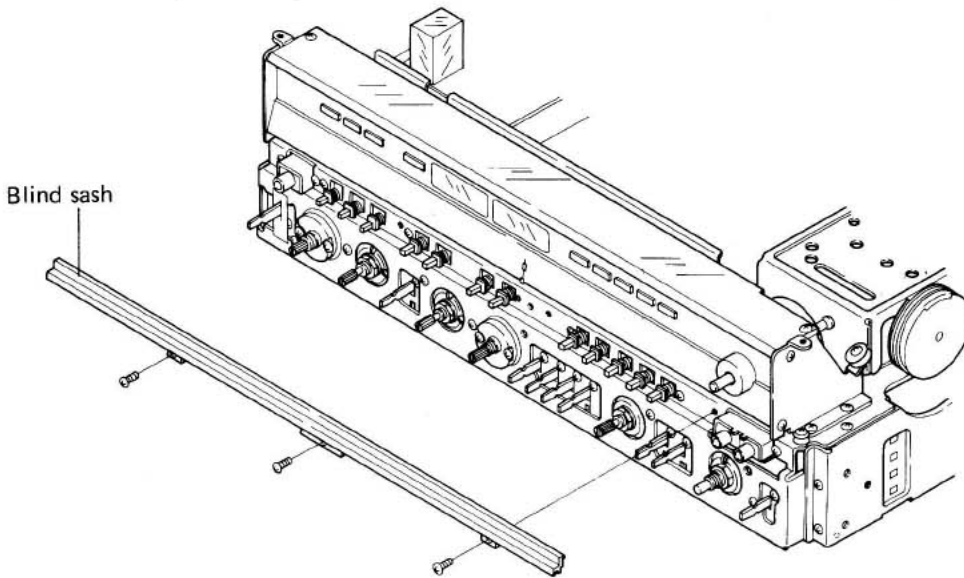

Fig. 26

Dial Pointer Installation Caution

Metal portion of dial pointer is plated approximately 0.2μ . If this section is touched directly by hand or fingerprints and other impurities adhere, it is difficult to remove dirt from aventurine finish. As this is not desirable in terms of both appearance and anticorrosion, take extreme care not to touch the metal portion when handling the dial pointer.

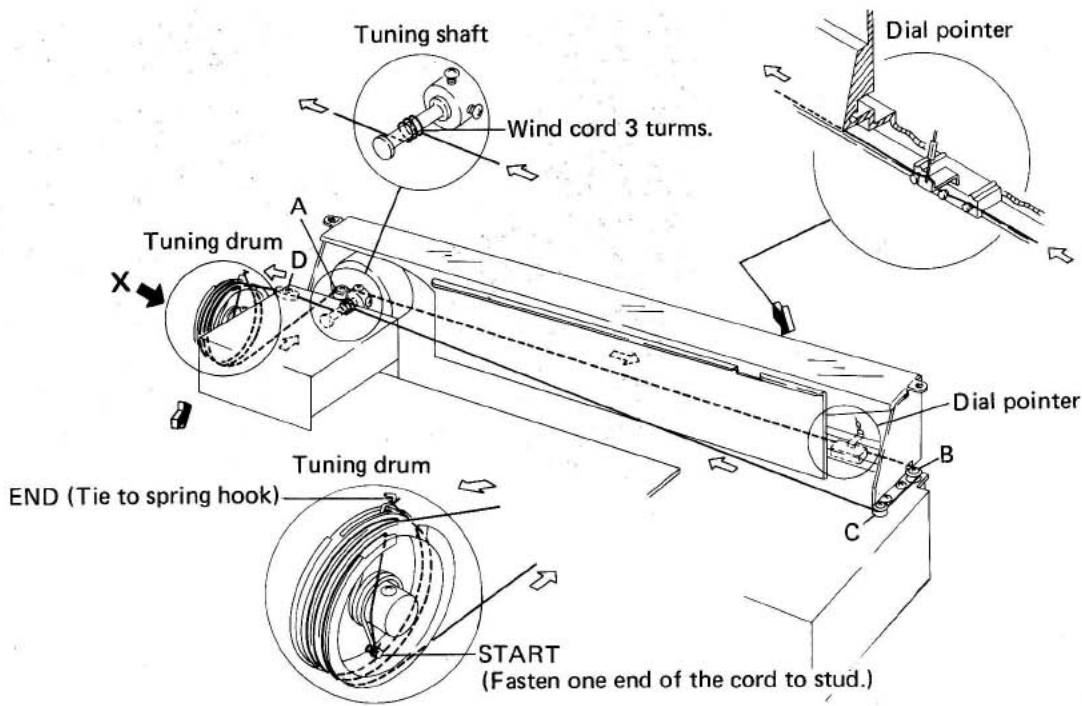

Fig. 27

10. ADJUSTMENTS

10.1 AM SECTION

1. Connect measuring equipment as shown in Fig. 28.
2. Set AM SG to 30% modulation at 400Hz and 30dB output.
3. Set AM switch on SX-1050 front panel to ON.
4. Tune AM SG and SX-1050 to dial readings of 600kHz.

5. Adjust cores of T9—T8—AM ferrite antenna for maximum audio frequency output level.
6. Tune AM SG and SX-1050 to dial readings of 1400kHz.
7. Adjust trimmers TC5—TC6—TC7 for maximum audio frequency output level.
8. Repeat steps 4 ~ 7 and adjust for maximum output and minimum deviation at each received frequency.

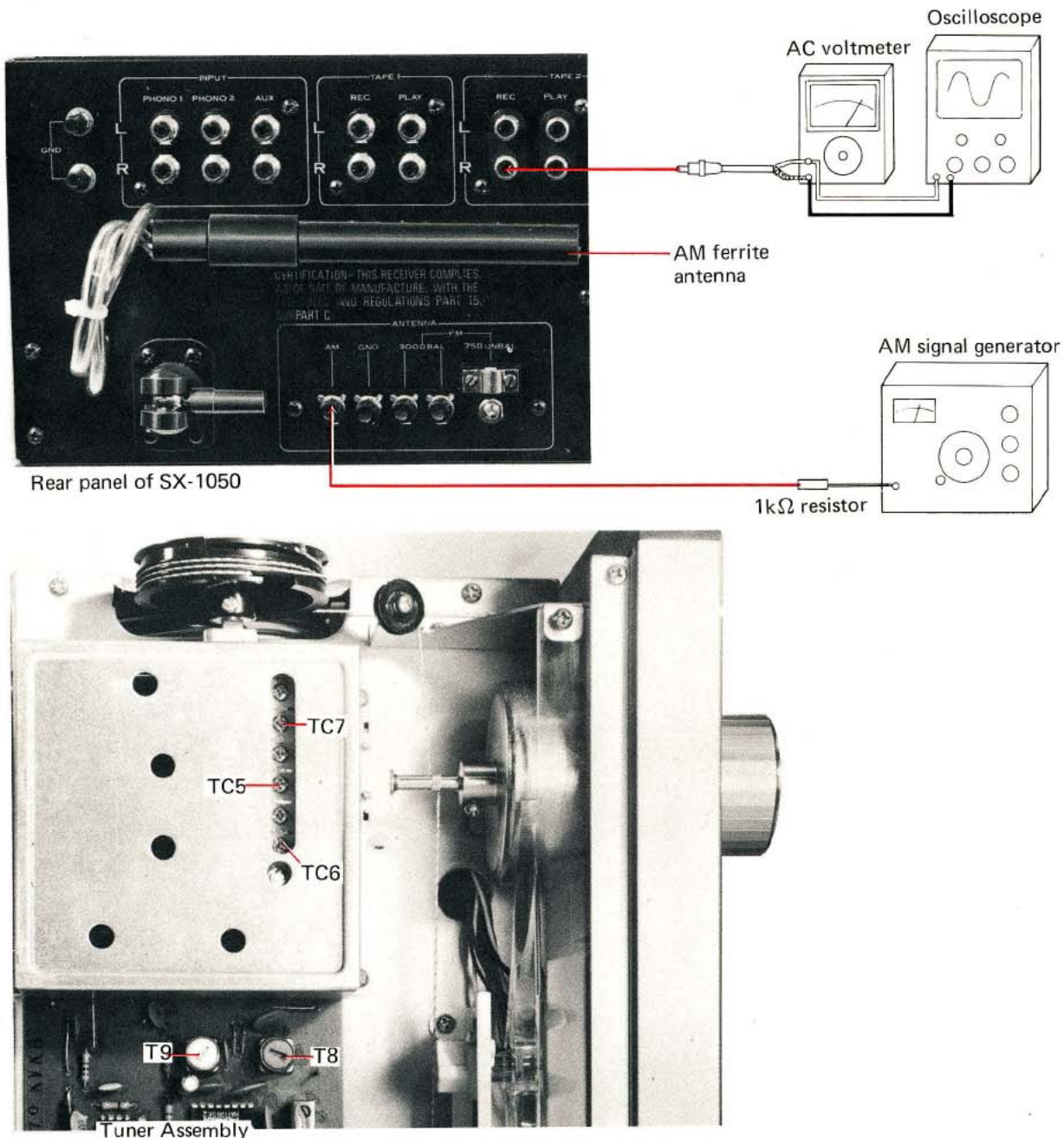

Fig. 28

10.2 FM SECTION

FM Tracking

1. Connect measuring equipment as shown in Fig. 29.
2. Set FM SG to 100% modulation ($\pm 75\text{kHz}$ deviation) at 400Hz and 100dB output.
3. On SX-1050 front panel, set FM switch to ON, FM muting to OFF and VOLUME control to minimum position.
4. Set TC4 to center of turning range.
5. Tune FM SG and SX-1050 to dial readings of 90MHz.
6. Adjust T4 core for maximum indication on Signal meter.
7. Adjust T6 core for center of scale indication on Tuning meter.
8. Set FM SG output to 8~10dB and adjust cores of T1, T2, and T3 for maximum indication on Signal meter.
9. Tune FM SG and SX-1050 to dial readings of 106MHz.
10. Set FM SG output to 100dB and adjust TC4 for maximum indication on Signal meter.
11. Set FM SG output to 8~10dB and adjust TC1, TC2 and TC3 for maximum indication on Signal meter.
12. Repeat above adjustment steps 5~11 and adjust for optimum conditions.
13. Tune FM SG and SX-1050 to dial readings of 90MHz.
14. Adjust T5 core for maximum indication on Signal meter.
15. Detune SX-1050 (to noise only).
16. Adjust T6 for center of scale indication on Tuning meter.
17. Tune FM SG and SX-1050 to dial readings of 98MHz.
18. Set FM SG output to 60dB and adjust upper core of T7 for DC millivolt meter reading of Less than $\pm 10\text{mV}$.
19. Adjust lower core of T7 for minimum audio frequency output distortion.
20. Confirm DC millivolt meter reading of less than $\pm 10\text{mV}$. If it exceeds $\pm 10\text{mV}$, repeat steps 18 and 19.
21. Set FM SG for 100dB output and adjust VR1 so that Signal meter indicates 5 of the scale.

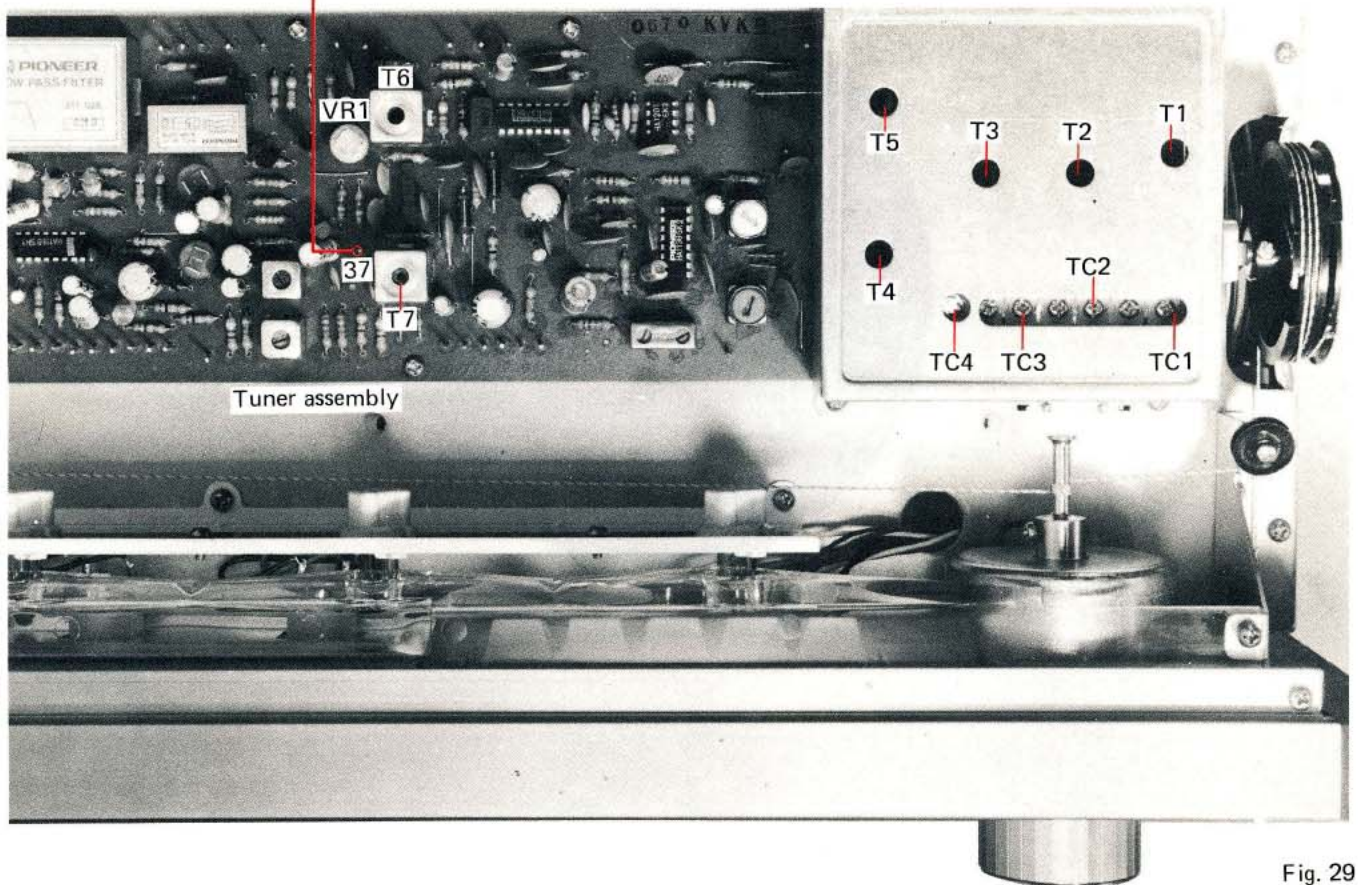
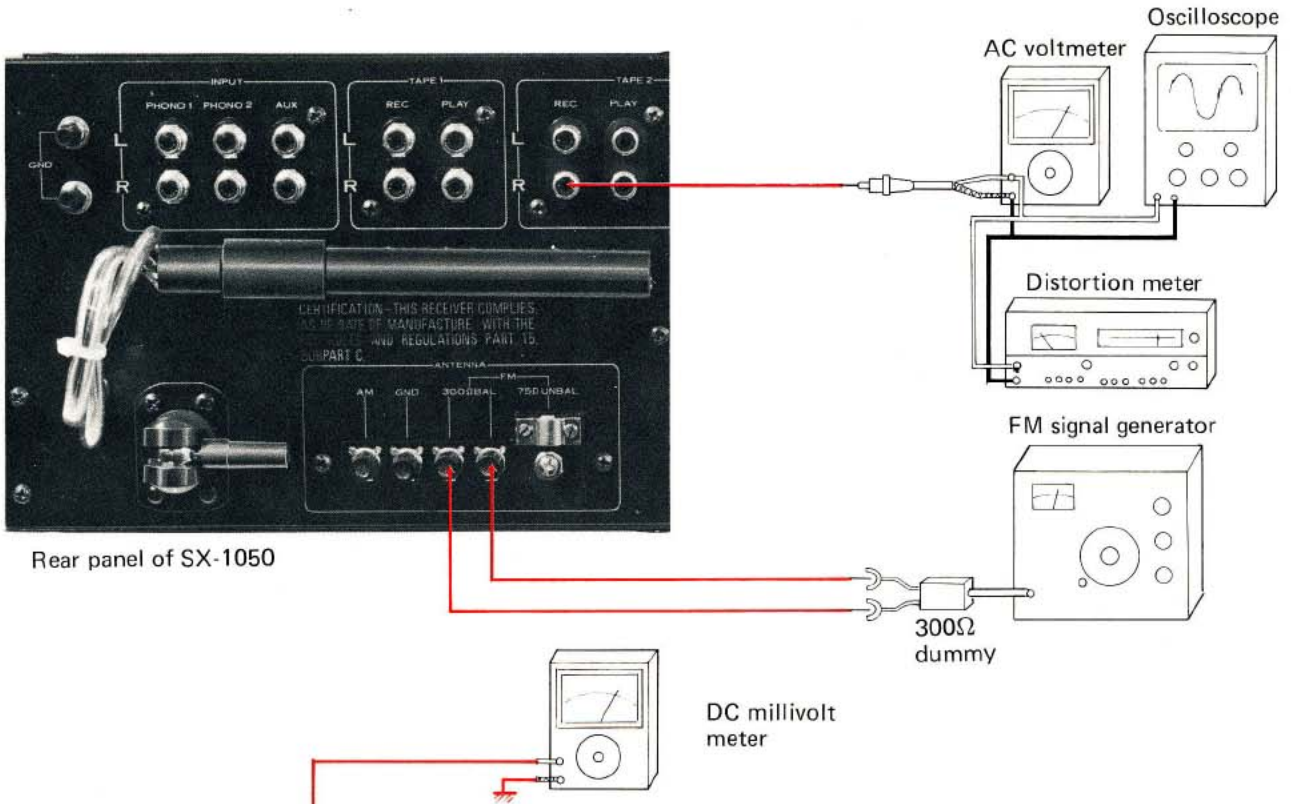

Fig. 29

MPX Adjustment

1. Connect measuring equipment as shown in Fig. 31.
2. Tune FM SG and SX-1050 to dial readings of 98MHz.
3. Set FM SG for 60dB unmodulated output.
4. Connect the output signal (19kHz) of MPX SG PILOT OUT terminal to the horizontal input of an oscilloscope, and pin 22 of the tuner assembly (AWE-067) via a probe to the oscilloscope vertical input.
5. Adjust VR3 so that lissajous pattern displayed on oscilloscope becomes stationary (Fig. 30).
6. Set MPX SG to 67.5kHz deviation at 1kHz for left and right channels, and to 7.5kHz deviation for 19kHz pilot signal.
7. Adjust T5 core for minimum audio frequency distortion. Take care to turn core only within $\pm 180^\circ$.
8. Adjust VR2 for minimum signal leakage from R channel to L channel, and from L channel to R channel.

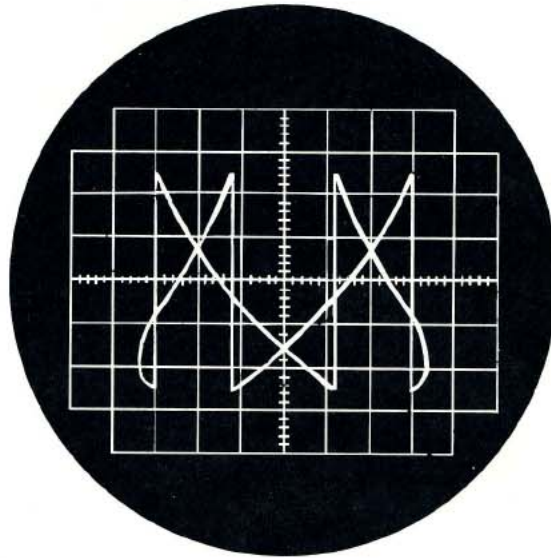

Fig. 30 Lissajous Pattern

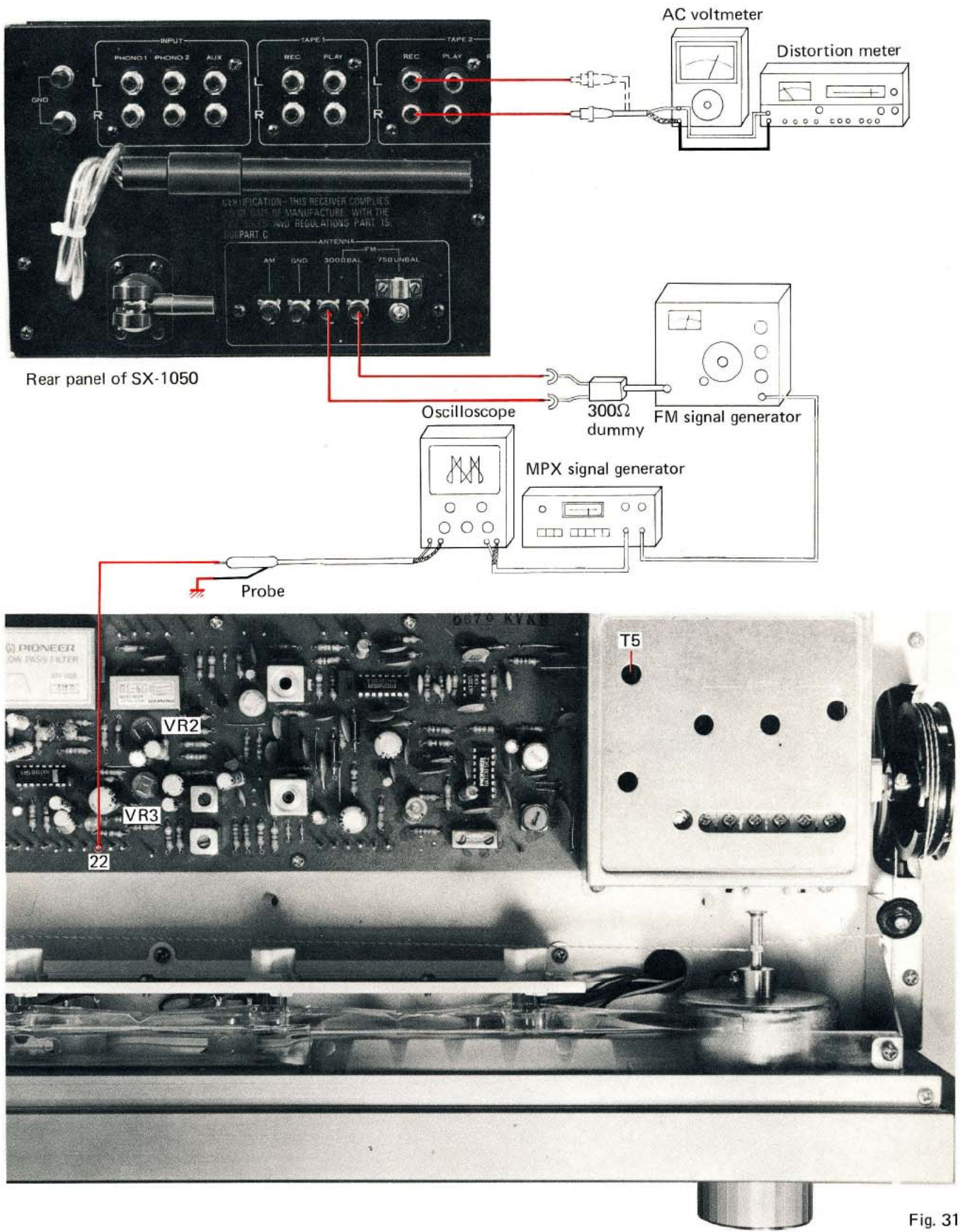

Fig. 31

10.3 POWER AMPLIFIER SECTION

DC Balance Adjustment

1. Connect DC voltmeter as shown in Fig. 32.
2. Do not connect load to speaker terminals. Set VOLUME control to minimum (fully counter-clockwise).
3. Adjust VR1 (L channel) and VR2 (R channel) for 0V indication on DC voltmeter.

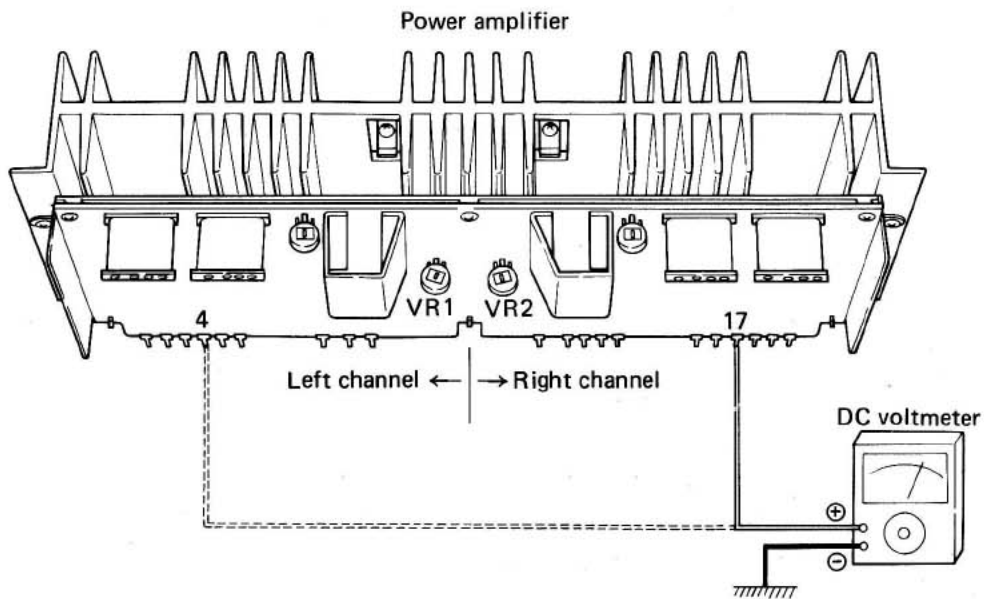

Fig. 32

Idle Current Adjustment

1. Connect DC voltmeter as shown in Fig. 33.
2. Do not connect load to speaker terminals. Set VOLUME control to minimum (fully counter-clockwise).
3. Turn VR3 and VR4 (shown in Fig. 33) fully counter-clockwise, then set POWER switch to ON.
4. 1~ 2 minutes after turning on the power, adjust VR3 (L channel) and VR4 (R channel) for 50mV indication on DC voltmeter.
5. 20 minutes after turning on the power, again adjust VR3 and VR4 for 50mV indication on DC voltmeter.

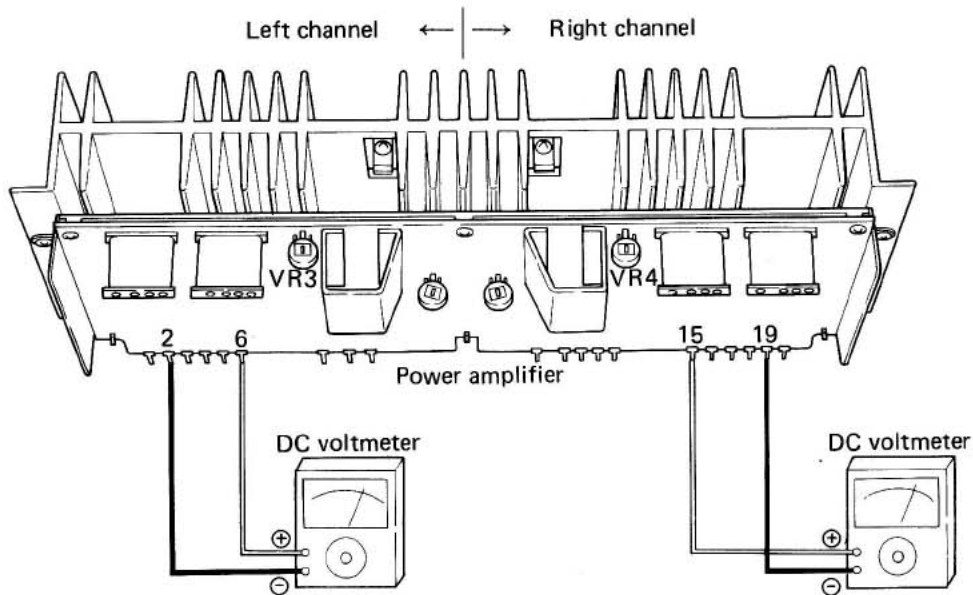

Fig. 33

11. EXPLODED VIEW

NOMENCLATURE OF SCREWS, WASHERS AND NUTS

The following symbols stand for screws, washers and nuts as shown in exploded view.

Symbol	Description	Shape
RT	Brazier head tapping screw	
PT	Pan head tapping screw	
BT	Binding head tapping screw	
CT	Countersunk head tapping screw	
TT	Truss head tapping screw	
OCT	Oval countersunk head tapping screw	
PM	Pan head machine screw	
CM	Countersunk head machine screw	
OCM	Oval countersunk head machine screw	
TM	Truss head machine screw	
BM	Binding head machine screw	
PSA	Pan head screw with spring lock washer	
PSB	Pan head screw with spring lock washer and flat washer	
PSF	Pan head screw with flat washer	

Symbol	Description	Shape
EW	E type washer	
FW	Flat washer	
SW	Spring lock washer	
N	Nut	
WN	Washer faced nut	
ITW	Internal toothed lock washer	
OTW	Outernal toothed lock washer	
SC	Slotted set screw (Cone point)	
SF	Slotted set screw (Flat point)	
HS	Hexagon socket headless set screw	
OCW	Oval countersunk head wood screw	
CW	Countersunk head wood screw	
RW	Round head wood screw	

EXAMPLE

PM 3x8
 length in mm (l)
 diameter in mm (d)
 Symbol

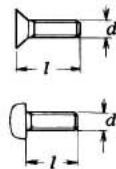

FW 9φx1^t
 thickness in mm (t)
 diameter in mm (d)
 Symbol

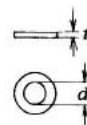

NOTE:
Parts indicated in green type cannot be supplied.

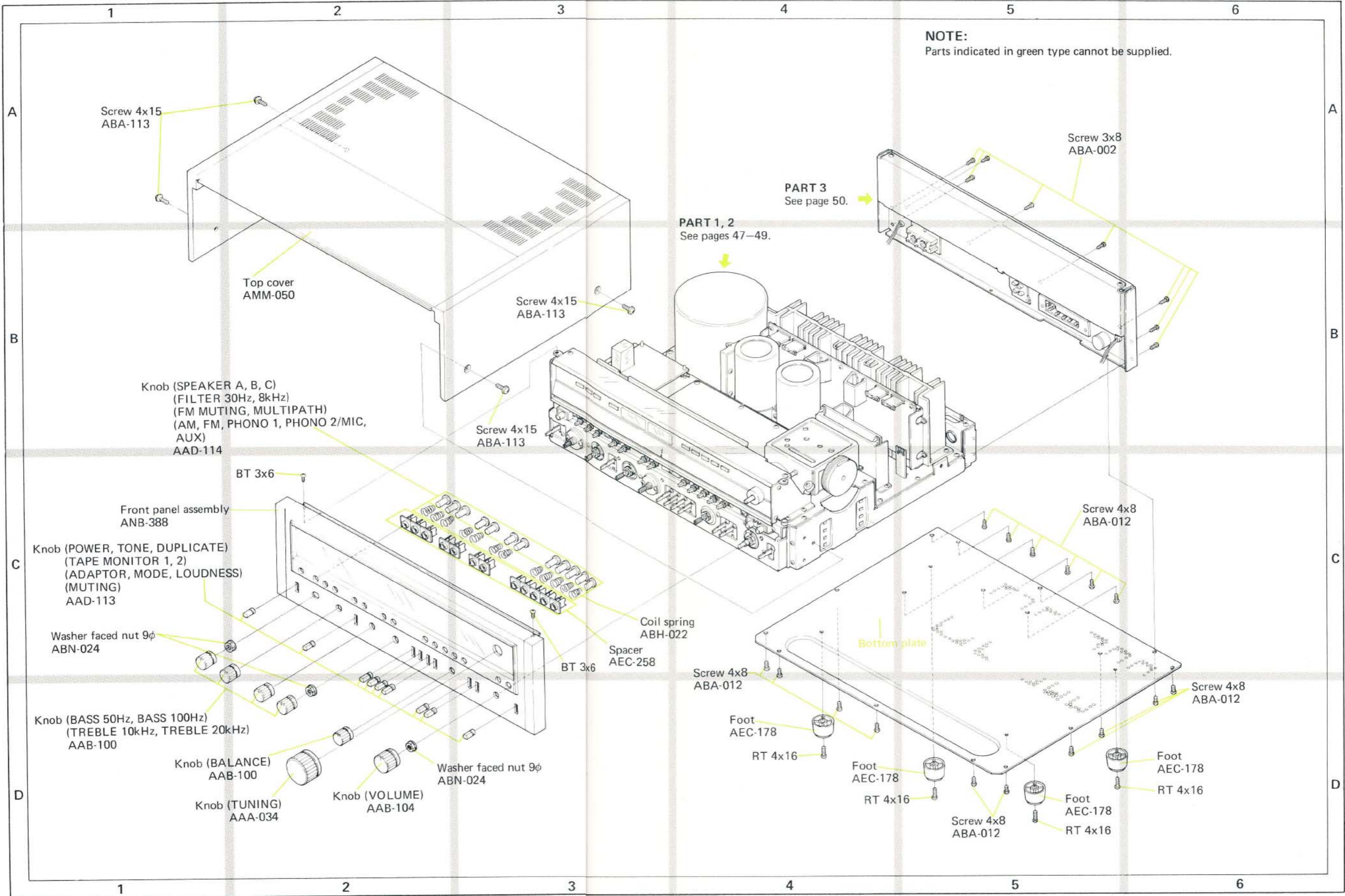

PART 1

NOTE:
Parts indicated in green type cannot be supplied.

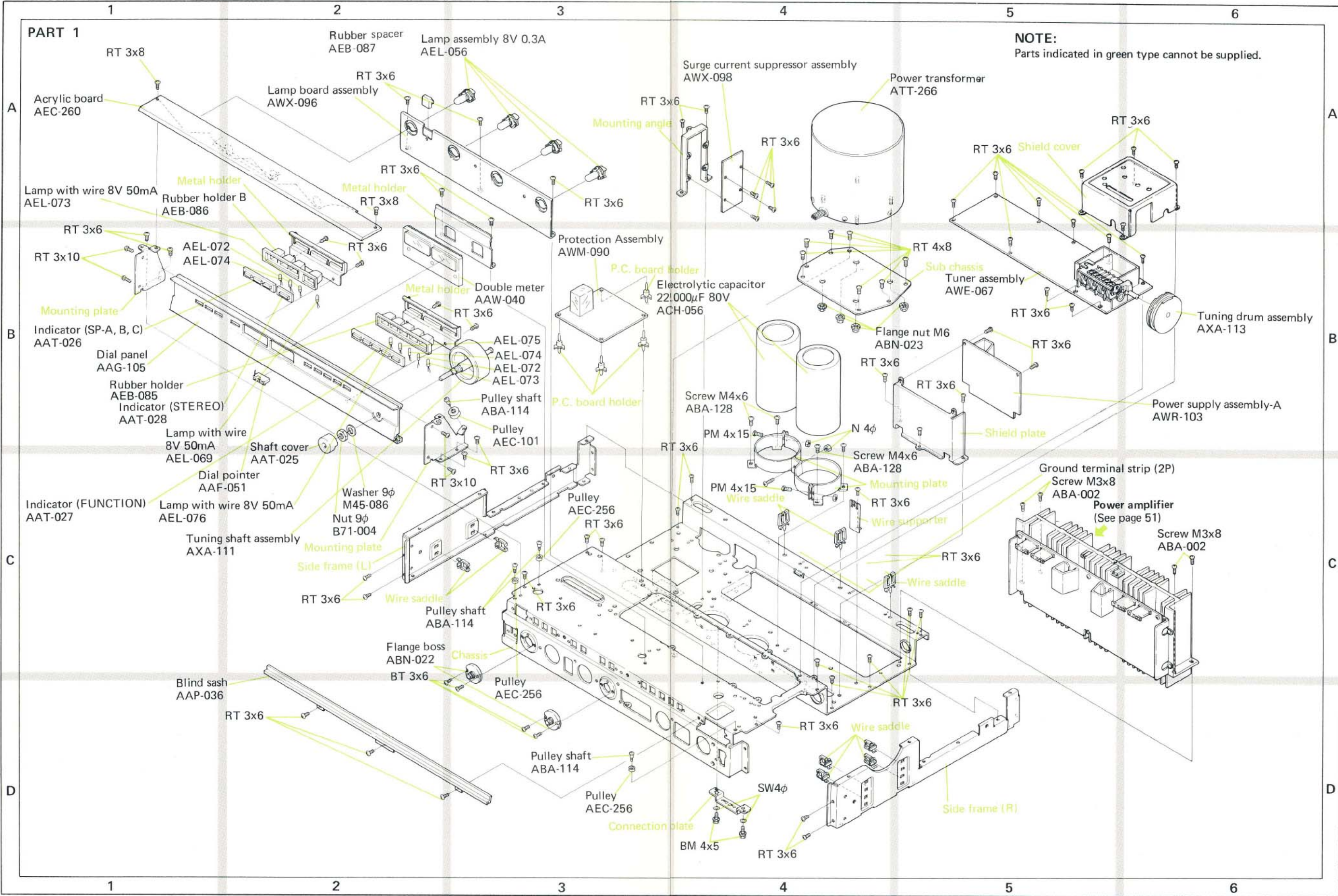

PART 2

NOTE:

Parts indicated in green type cannot be supplied.

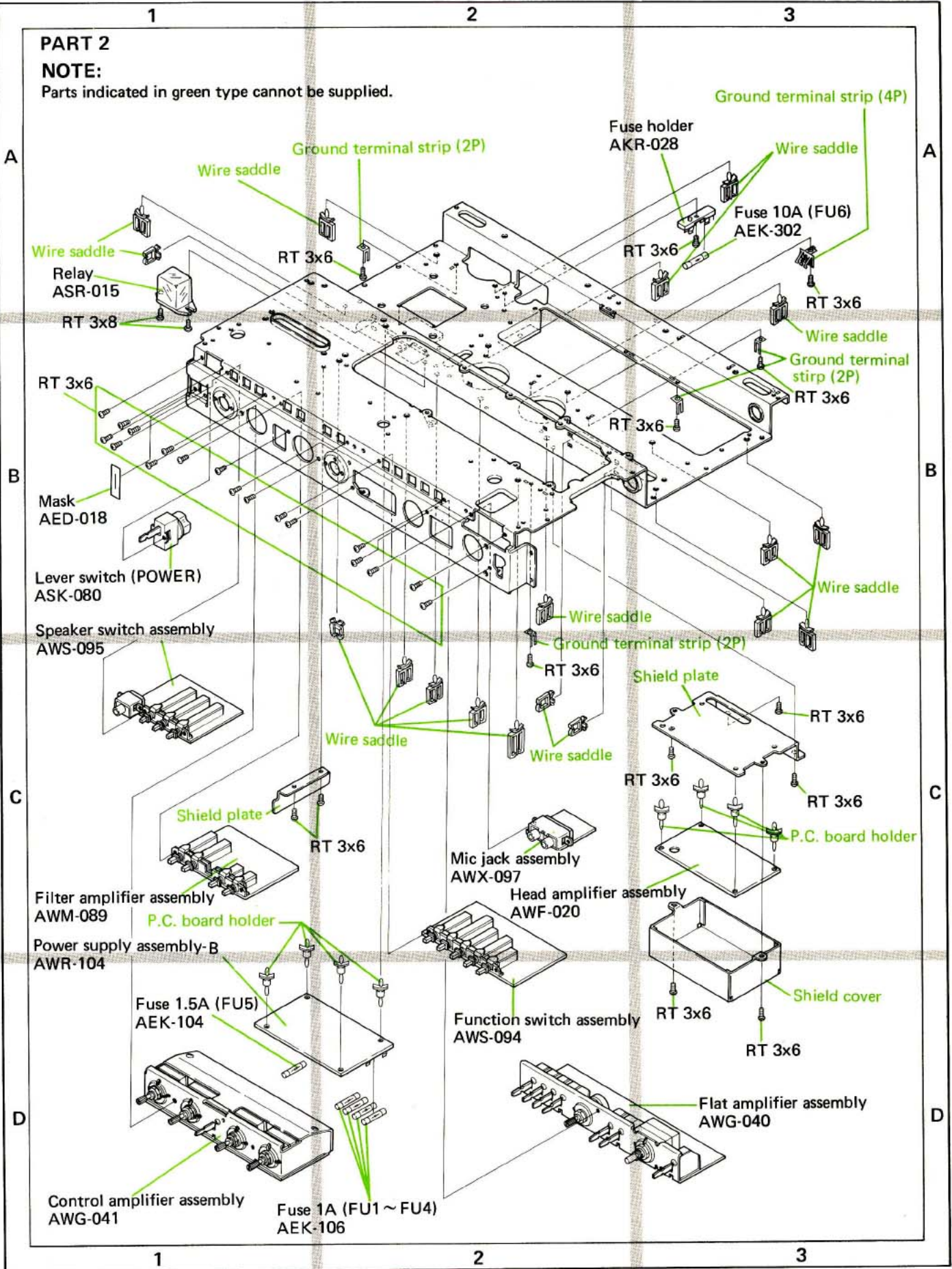

PART 3

NOTE:

Parts indicated in green type cannot be supplied.

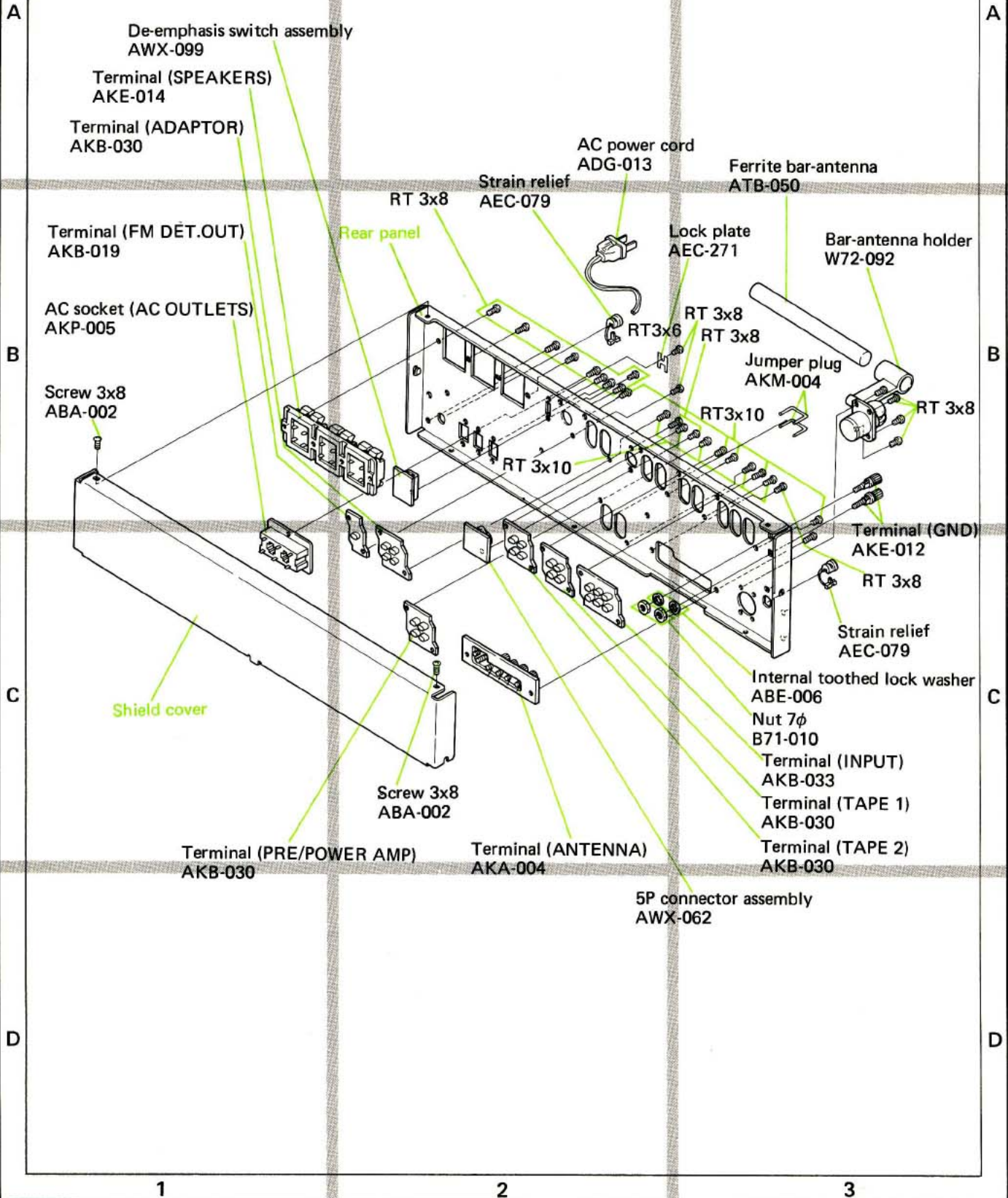

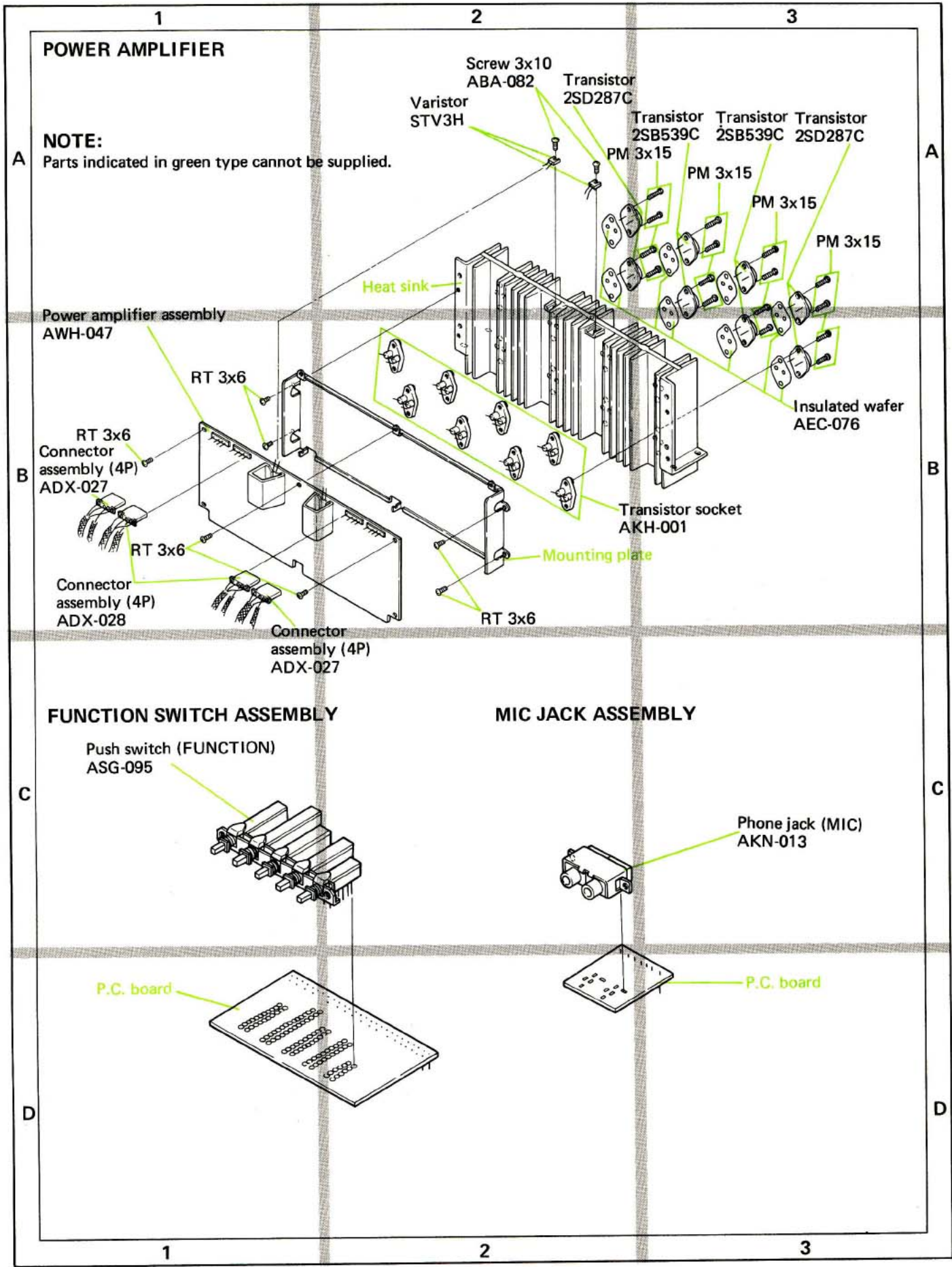

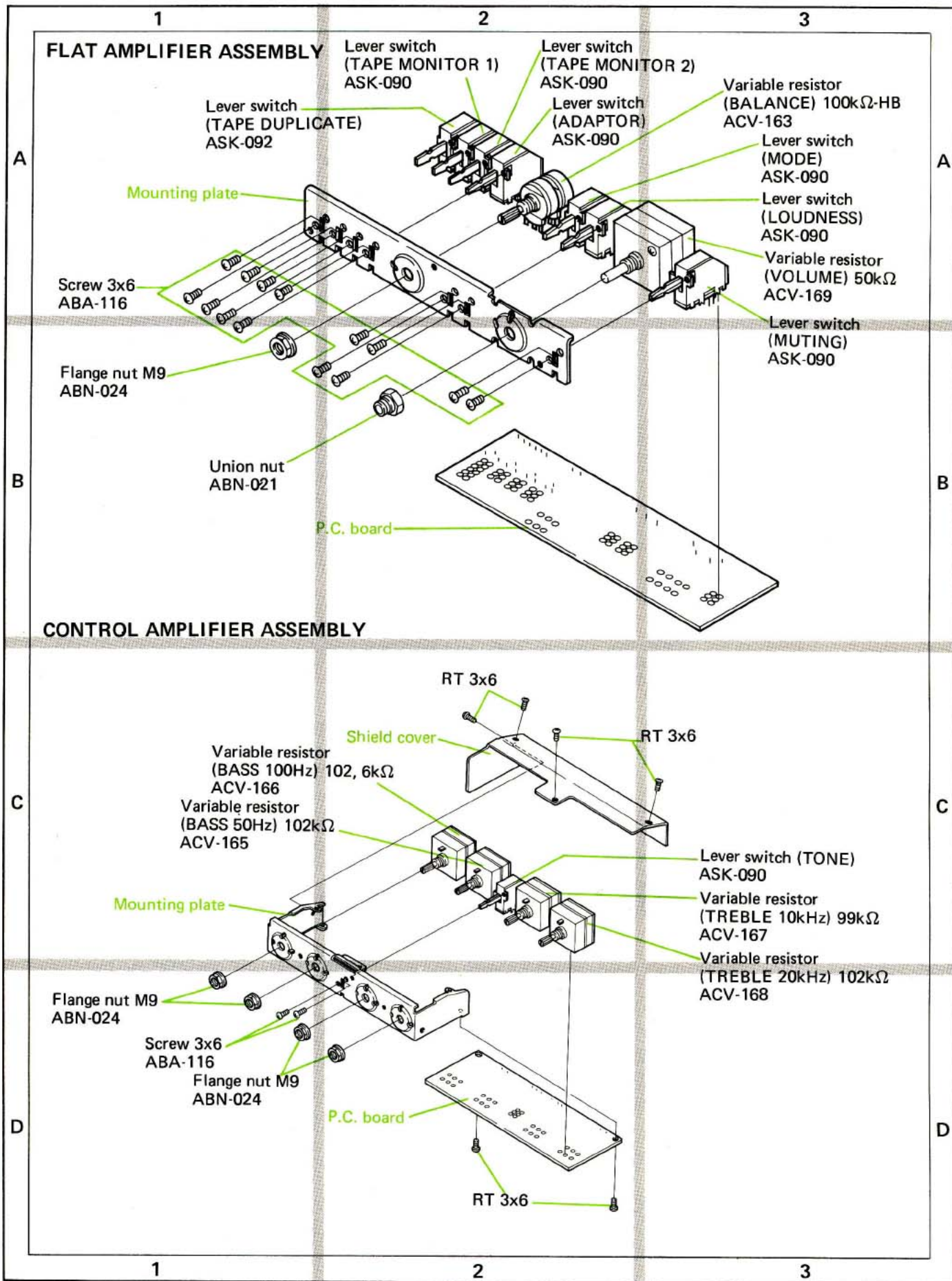

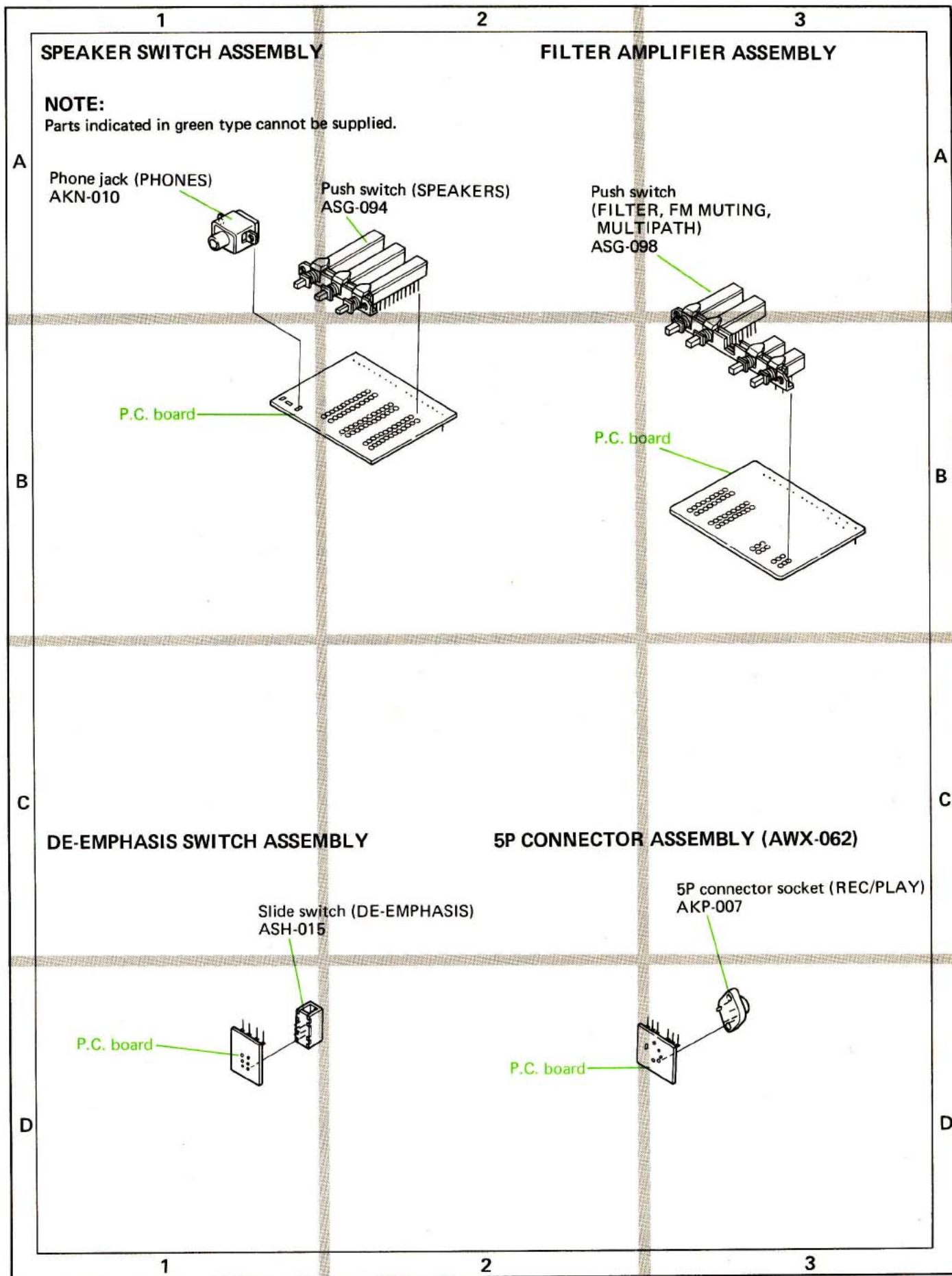

12. SCHEMATIC DIAGRAMS, P.C. BOARD PATTERNS AND PARTS LIST

12.1 SCHEMATIC DIAGRAM AND MISCELLANEOUS PARTS

Miscellaneous Parts List

NOTE:

- Capacitors: in μF unless otherwise noted p:pF
- Resistors: in Ω , $\frac{1}{4}W$ unless otherwise noted k:k Ω , M:M Ω

SEMICONDUCTORS

Symbol	Description	Part No.
Q23	Transistor	2SB539C-S
Q24	Transistor	2SB539C-S
Q25	Transistor	2SD287C-S
Q26	Transistor	2SD287C-S
Q27	Transistor	2SB539C-S
Q28	Transistor	2SB539C-S
Q29	Transistor	2SD287C-S
Q30	Transistor	2SD287C-S

FUSES

Symbol	Description	Part No.
F1	Fuse 1A	AEK-106
F2	Fuse 1A	AEK-106
F3	Fuse 1A	AEK-106
F4	Fuse 1A	AEK-106
F5	Fuse 1.5A	AEK-104
F6	Fuse 10A	AEK-302

SWITCHES

Symbol	Description	Part No.
S1	Lever switch (POWER)	ASK-080
S2	Relay	ASR-015

LAMPS

Symbol	Description	Part No.
PL1	Lamp assembly 8V 300mA	AEL-056
PL2	Lamp assembly 8V 300mA	AEL-056
PL3	Lamp assembly 8V 300mA	AEL-056
PL4	Lamp assembly 8V 300mA	AEL-056
PL5	Lamp with wire 8V 50mA	AEL-074
PL6	Lamp with wire 8V 50mA	AEL-072
PL7	Lamp with wire 8V 50mA	AEL-073
PL8	Lamp with wire 8V 50mA	AEL-076
PL9	Lamp with wire 8V 50mA	AEL-075
PL10	Lamp with wire 8V 50mA	AEL-074
PL11	Lamp with wire 8V 50mA	AEL-072
PL12	Lamp with wire 8V 50mA	AEL-073
PL13	Lamp with wire 8V 50mA	AEL-069

TRANSFORMERS AND COIL

Symbol	Description	Part No.
T1	Ferrite balun	T22-025
T2	Ferrite bar-antenna	ATB-050
T3	Power transformer	ATT-266

RESISTOR AND CAPACITORS

Symbol	Description	Part No.
R1	Carbon film 2.2M $\frac{1}{4}W$	RD $\frac{1}{4}$ PS 225J
C1	Electrolytic 22000 80V	ACH-056
C2	Electrolytic 22000 80V	ACH-056
C3	Ceramic 0.01 150V	ACG-003
C4	Ceramic 0.01 150V	ACG-003
C5	Ceramic 0.01 50V	CKDYF 103Z 50
C6	Ceramic 0.01 50V	CKDYF 103Z 50
C7	Ceramic 0.01 50V	CKDYF 103Z 50
C8	Ceramic 0.01 50V	CKDYF 103Z 50
C9	Ceramic 0.01 50V	CKDYF 103Z 50
C10	Ceramic 0.01 50V	CKDYF 103Z 50
C11	Ceramic 0.01 50V	CKDYF 103Z 50

Circuit Diagrams of ICs

HA1137 (FM IF IC)

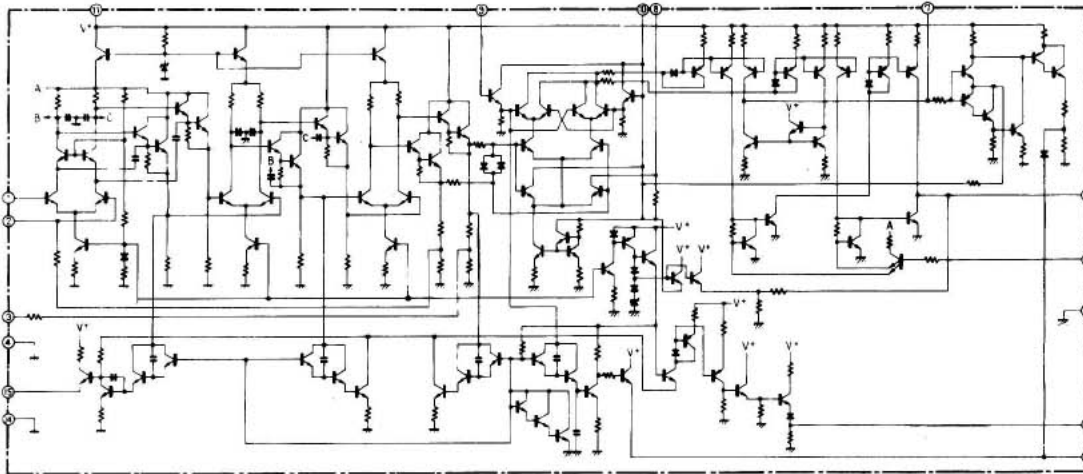

HA1138 (AM IC)

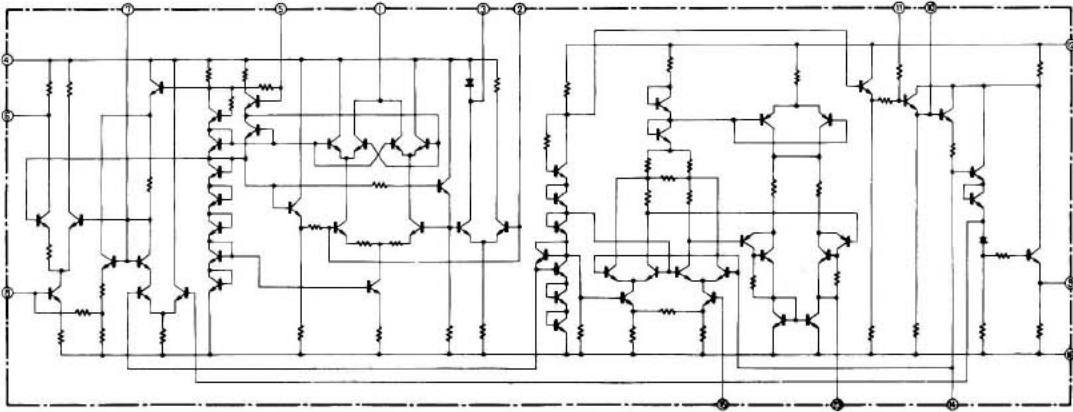

HA1196 (FM MPX IC)

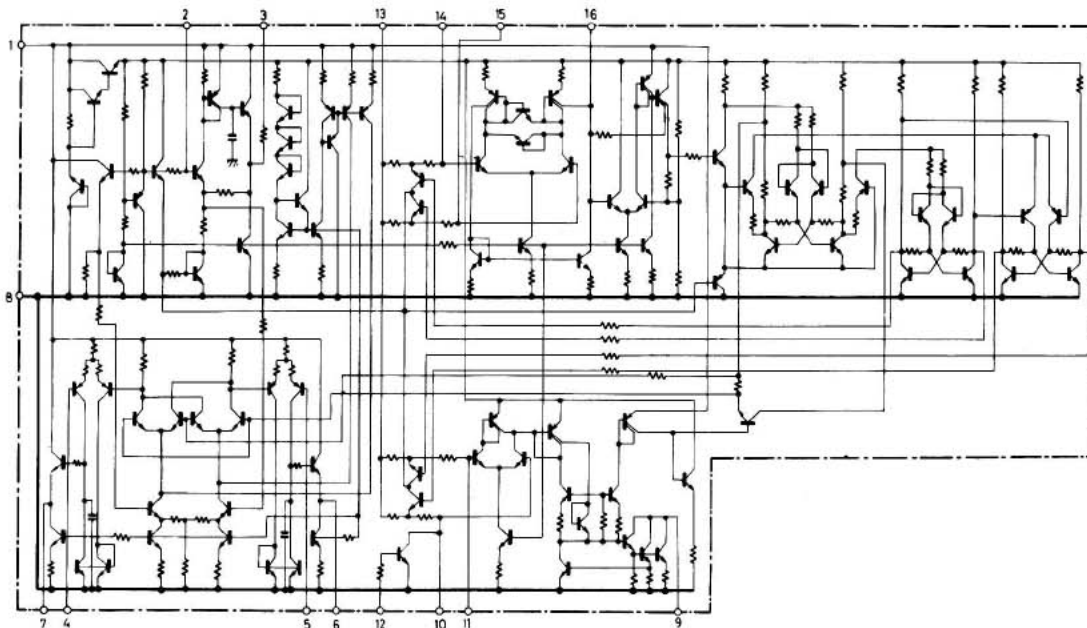

HA1201

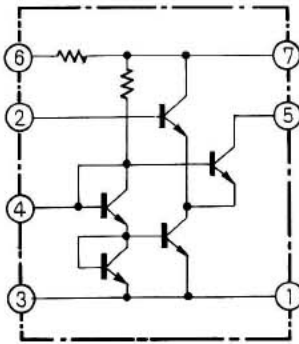

TA 7061A

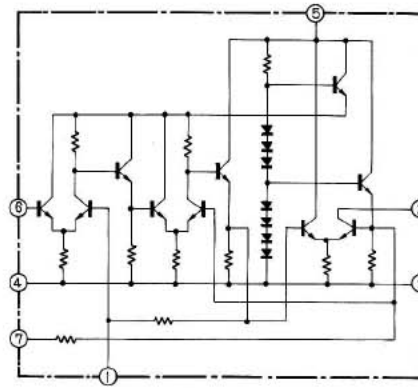

External Appearance of Transistors and ICs

- 2SA720
- 2SA733
- 2SA750
- 2SA858
- 2SA872A
- 2SC945A
- 2SC1318
- 2SC1439
- 2SC1775A

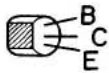

- 2SC461
- 2SC717

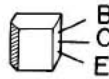

- 2SB539C
- 2SD289C

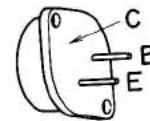

- 2SB507P
- 2SB536A
- 2SD313P
- 2SD381A
- 2SD325R

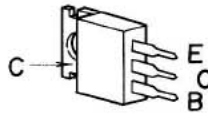

- 2SA725
- 2SC869
- 2SC1312
- 2SC1313



- 2SC1384

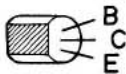

- 2SK30AW



- 3SK45

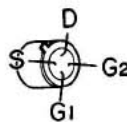

- HA1137
- HA1138
- HA1196

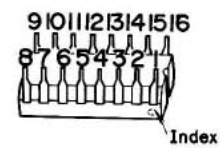

- HA1201

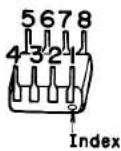

- TA7061AP

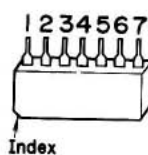

- 2SA841S

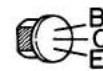

12.2 TUNER ASSEMBLY (AWE-067)

Total Current FM Position $I_{typ} = 120\text{mA}$
 AM Position $I_{typ} = 105\text{mA}$

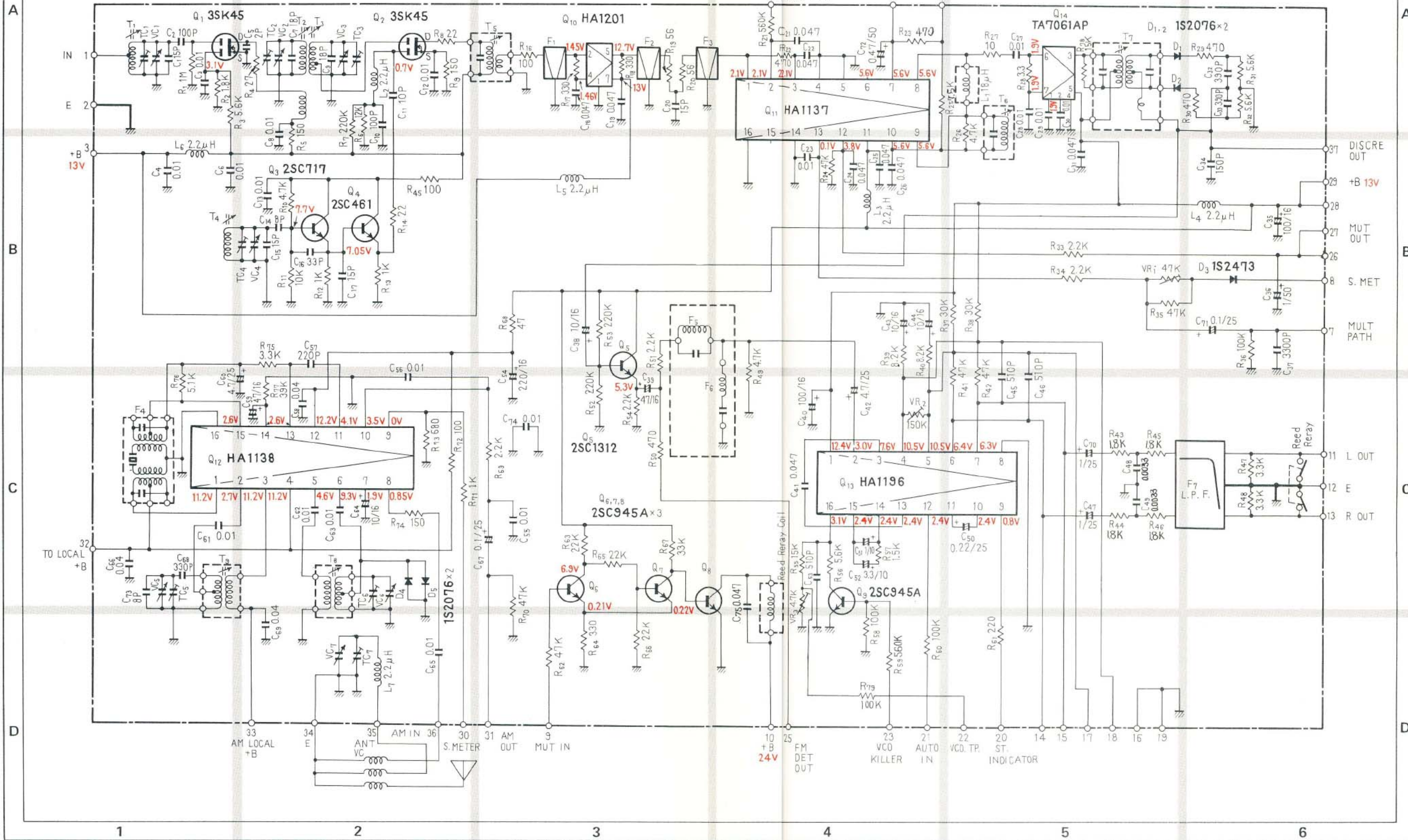

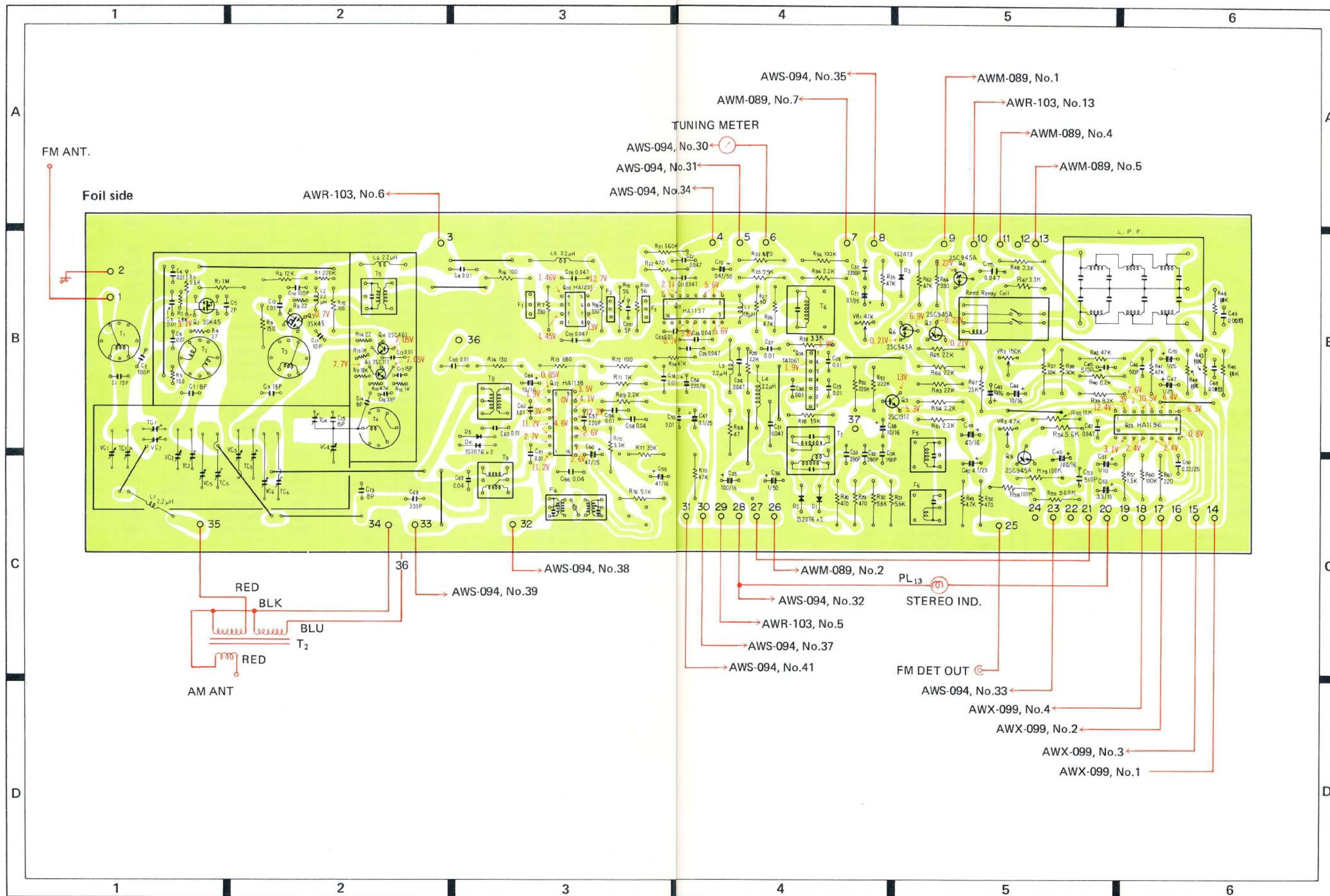

Parts List of Tuner Assembly (AWE-067)

SEMICONDUCTORS

Symbol	Description	Part No.
Q1	FET	3SK45-B
Q2	FET	3SK45-B
Q3	Transistor	2SC717
Q4	Transistor	2SC461-B
Q5	Transistor	2SC1312-G
Q6	Transistor	2SC945A-Q
Q7	Transistor	2SC945A-Q
Q8	Transistor	2SC945A-Q
Q9	Transistor	2SC945A-Q
Q10	IC	HA1201
Q11	IC	HA1137
Q12	IC	HA1138
Q13	IC	HA1196
Q14	IC	TA7061AP
D1	Diode	1S2076
D2	Diode	1S2076
D3	Diode	1S2473
D4	Diode	1S2076
D5	Diode	1S2076

TRANSFORMERS, FILTERS AND COILS

Symbol	Description	Part No.
T1	FM antenna coil	ATC-021
T2	FM RF coil	ATC-015
T3	FM RF coil	ATC-016
T4	FM OSC coil	ATC-022
T5	FM IF transformer	ATE-008
T6	FM IF transformer	ATE-029
T7	FM IF transformer	ATE-013
T8	AM RF coil	ATB-014
T9	AM OSC coil	ATB-013
F1	FM ceramic filter	ATF-013
F2	FM ceramic filter	ATF-013
F3	FM ceramic filter	ATF-013
F4	AM ceramic filter	ATF-027
F5	Anti-birdy filter	ATF-023
F6	Anti-birdy filter	ATF-024
F7	FM low pass filter	ATF-028
L1	Choke coil	18 μ H ATH-007
L2	RF choke coil	2.2 μ H T24-028
L3	RF choke coil	2.2 μ H T24-028
L4	RF choke coil	2.2 μ H T24-028
L5	RF choke coil	2.2 μ H T24-028
L6	RF choke coil	2.2 μ H T24-028
L7	RF choke coil	2.2 μ H T24-028

RESISTORS AND POTENTIOMETERS

Symbol	Description	Part No.
R1	Carbon film 1M	RD $\frac{1}{4}$ PS 105J
R2	Carbon film 1.8k	RD $\frac{1}{4}$ VS 182J
R3	Carbon film 5.6k	RD $\frac{1}{4}$ PS 562J
R4	Carbon film 27	RD $\frac{1}{4}$ VS 270J
R5	Carbon film 150	RD $\frac{1}{4}$ VS 151J
R6	Carbon film 12k	RD $\frac{1}{4}$ PS 123J
R7	Carbon film 220k	RD $\frac{1}{4}$ VS 224J
R8	Carbon film 22	RD $\frac{1}{4}$ VS 220J
R9	Carbon film 150	RD $\frac{1}{4}$ PS 151J
R10	Carbon film 4.7k	RD $\frac{1}{4}$ VS 472J
R11	Carbon film 10k	RD $\frac{1}{4}$ VS 103J
R12	Carbon film 1k	RD $\frac{1}{4}$ VS 102J
R13	Carbon film 1k	RD $\frac{1}{4}$ VS 102J
R14	Carbon film 22	RD $\frac{1}{4}$ VS 220J
R15	Carbon film 100	RD $\frac{1}{4}$ PS 101J
R16	Carbon film 100	RD $\frac{1}{4}$ PS 101J
R17	Carbon film 330	RD $\frac{1}{4}$ PS 331J
R18	Carbon film 330	RD $\frac{1}{4}$ PS 331J
R19	Carbon film 56	RD $\frac{1}{4}$ PS 560J
R20	Carbon film 56	RD $\frac{1}{4}$ PS 560J
R21	Carbon film 560k	RD $\frac{1}{4}$ PS 564J
R22	Carbon film 470	RD $\frac{1}{4}$ PS 471J
R23	Carbon film 470	RD $\frac{1}{4}$ PS 471J
R24	Carbon film 47k	RD $\frac{1}{4}$ PS 473J
R25	Carbon film 7.5k	RD $\frac{1}{4}$ PS 752J
R26	Carbon film 4.7k	RD $\frac{1}{4}$ PS 472J
R27	Carbon film 10	RD $\frac{1}{4}$ PS 100J
R28	Carbon film 3.3k	RD $\frac{1}{4}$ PS 332J
R29	Carbon film 470	RD $\frac{1}{4}$ PS 471J
R30	Carbon film 470	RD $\frac{1}{4}$ PS 471J
R31	Carbon film 5.6k	RD $\frac{1}{4}$ PS 562J
R32	Carbon film 5.6k	RD $\frac{1}{4}$ PS 562J
R33	Carbon film 2.2k	RD $\frac{1}{4}$ PS 222J
R34	Carbon film 2.2k	RD $\frac{1}{4}$ PS 222J
R35	Carbon film 47k	RD $\frac{1}{4}$ PS 473J
R36	Carbonfilm 100k	RD $\frac{1}{4}$ PS 104J
R37	Carbon film 30k	RD $\frac{1}{4}$ PS 303J
R38	Carbon film 30k	RD $\frac{1}{4}$ PS 303J
R39	Carbon film 8.2k	RD $\frac{1}{4}$ PS 822J
R40	Carbon film 8.2k	RD $\frac{1}{4}$ PS 822J
R41	Carbon film 47k	RD $\frac{1}{4}$ PS 473J
R42	Carbon film 47k	RD $\frac{1}{4}$ PS 473J
R43	Carbon film 1.8k	RD $\frac{1}{4}$ PS 182J
R44	Carbon film 1.8k	RD $\frac{1}{4}$ PS 182J
R45	Carbon film 1.8k	RD $\frac{1}{4}$ PS 182J
R46	Carbon film 1.8k	RD $\frac{1}{4}$ PS 182J
R47	Carbon film 3.3k	RD $\frac{1}{4}$ PS 332J
R48	Carbon film 3.3k	RD $\frac{1}{4}$ PS 332J

Symbol	Description	Part No.
R49	Carbon film 4.7k	RD%PS 472J
R50	Carbon film 470	RD%PS 471J
R51	Carbon film 2.2k	RD%PS 222J
R52	Carbon film 220k	RD%PS 224J
R53	Carbon film 220k	RD%PS 224J
R54	Carbon film 2.2k	RD%PS 222J
R55	Carbon film 15k	RD%PS 153J
R56	Carbon film 5.6k	RD%PS 562J
R57	Carbon film 1.5k	RD%PS 152J
R58	Carbon film 100k	RD%PS 104J
R59	Carbon film 560k	RD%PS 564J
R60	Carbon film 100k	RD%PS 104J
R61	Carbon film 220	RD%PS 221J
R62	Carbon film 47k	RD%PS 473J
R63	Carbon film 22k	RD%PS 223J
R64	Carbon film 330	RD%PS 331J
R65	Carbon film 22k	RD%PS 223J
R66	Carbon film 22k	RD%PS 223J
R67	Carbon film 33k	RD%PS 333J
R68	Carbon film 47	RD%PS 470J
R69	Carbon film 2.2k	RD%PS 222J
R70	Carbon film 47k	RD%PS 473J
R71	Carbon film 1k	RD%PS 102J
R72	Carbon film 100	RD%PS 101J
R73	Carbon film 680	RD%PS 681J
R74	Carbon film 150	RD%PS 151J
R75	Carbon film 3.3k	RD%PS 332J
R76	Carbon film 5.1k	RD%PS 512J
R77	Carbon film 39k	RD%PS 393J
R78	Carbon film 15k	RD%PS 153J
R79	Carbon film 100k	RD%PS 104J
VR1	Semi-fixed 4.7k	ACP-018
VR2	Semi-fixed 150k	ACP-014
VR3	Semi-fixed 47k	C92-048

CAPACITORS

Symbol	Description	Part No.
VC	Tuning capacitor	ACK-016
TC4	Ceramic trimmer	C43-007
C1	Ceramic 15p 50V	CCDSH 150K 50
C2	Ceramic 100p 50V	CCDSL 101K 50
C3	Ceramic 0.01 50V	CKDYF 103Z 50
C4	Ceramic 0.01 50V	CKDYF 103Z 50
C5	Ceramic 2p 50V	CCDSL 020C 50
C6	Ceramic 0.01 50V	CKDYF 103Z 50
C7	Ceramic 18p 50V	CCDSH 180K 50
C8	Ceramic 0.01 50V	CKDYF 103Z 50
C9	Ceramic 18p 50V	CCDSH 180K 50
C10	Ceramic 100p 50V	CCDSL 101K 50

Symbol	Description	Part No.
C11	Ceramic 10p 50V	CCDSL 100F 50
C12	Ceramic 0.01 50V	CKDYF 103Z 50
C13	Ceramic 0.01 50V	CKDYF 103Z 50
C14	Ceramic 8p 50V	CCDLH 080F 50
C15	Ceramic 15p 50V	CCDLH 150K 50
C16	Ceramic 33p 50V	CCDCH 330K 50
C17	Ceramic 15p 50V	CCDCH 150K 50
C18	Ceramic 0.047 25V	CKDBC 473Z 25
C19	Ceramic 0.047 25V	CKDBC 473Z 25
C20	Ceramic 15p 50V	CCDSL 150K 50
C21	Ceramic 0.047 25V	CKDBC 473Z 25
C22	Ceramic 0.047 25V	CKDBC 473Z 25
C23	Ceramic 0.01 50V	CKDYF 103Z 50
C24	Ceramic 0.047 25V	CKDBC 473Z 25
C25	Ceramic 0.047 25V	CKDBC 473Z 25
C26	Ceramic 0.047 25V	CKDBC 473Z 25
C27	Ceramic 0.01 50V	CKDYF 103Z 50
C28	Ceramic 0.01 50V	CKDYF 103Z 50
C29	Ceramic 0.01 50V	CKDYF 103Z 50
C30	Ceramic 0.01 50V	CKDYF 103Z 50
C31	Ceramic 0.047 25V	CKDBC 473Z 25
C32	Ceramic 390p 50V	CCDSL 391K 50
C33	Ceramic 390p 50V	CCDSL 391K 50
C34	Ceramic 150p 50V	CCDSL 151K 50
C35	Electrolytic 100 16V	CEA 101P 16
C36	Electrolytic 1 50V	CEA 010P 50
C37	Ceramic 3300p 50V	CKDYA 332J 50
C38	Electrolytic 10 16V	CEANL 100P 16
C39	Electrolytic 47 16V	CEANL 470P 16
C40	Electrolytic 100 16V	CEA 101P 16
C41	Mylar 0.047 50V	CQMA 473J 50
C42	Electrolytic 4.7 25V	CEANL 4R7P 25
C43	Electrolytic 10 16V	CEANL 100P 16
C44	Electrolytic 10 16V	CEANL 100P 16
C45	Styrol 510p 50V	CQSA 511J 50
C46	Styrol 510p 50V	CQSA 511J 50
C47	Electrolytic 1 25V	CEANL 010P 25
C48	Mylar 0.0033 50V	CQMA 332K 50
C49	Mylar 0.0033 50V	CQMA 332K 50
C50	Electrolytic 0.22 25V	CSSA R22M 25
C51	Electrolytic 1 10V	CSSA 010M 10
C52	Electrolytic 3.3 10V	CSSA 3R3M 10
C53	Styrol 510p 50V	CQSH 511J 50
C54	Electrolytic 220 16V	CEA 221P 16
C55	Ceramic 0.01 50V	CKDYF 103Z 50
C56	Ceramic 0.01 50V	CKDYF 103Z 50
C57	Ceramic 220p 50V	CCDSL 221K 50
C58	Ceramic 0.04 50V	CKDYF 403Z 50
C59	Electrolytic 47 16V	CEA 470P 16
C60	Electrolytic 4.7 25V	CEA 4R7P 25

Symbol	Description			Part No.
C61	Ceramic	0.01	50V	CDKYA 103J 50
C62	Ceramic	0.01	50V	CKDYF 103Z 50
C63	Ceramic	0.01	50V	CKDYF 103Z 50
C64	Electrolytic	10	16V	CEA 100P 16
C65	Ceramic	0.01	50V	CKDYF 103Z 50
C66	Ceramic	0.04	50V	CKDYF 403Z 50
C67	Electrolytic	0.1	25V	CSSA 0R1M 25
C68	Styrol	330p	50V	CQSA 331J 50
C69	Ceramic	0.04	50V	CKDYF 403Z 50
C70	Electrolytic	1	25V	CEANL 010P 25
C71	Electrolytic	0.1	25V	CSSA 0R1M 25
C72	Electrolytic	0.47	50V	CEA R47P 50
C73	Ceramic	8p	50V	CCDXL 080F 50
C74	Ceramic	0.01	50V	CKDYF 103Z 50
C75	Ceramic	0.047	25V	CKDBC 473Z 25

OTHER

Symbol	Description	Part No.
	Reed relay	ASR-005

12.3 EQUALIZER AMPLIFIER ASSEMBLY (AWF-020)

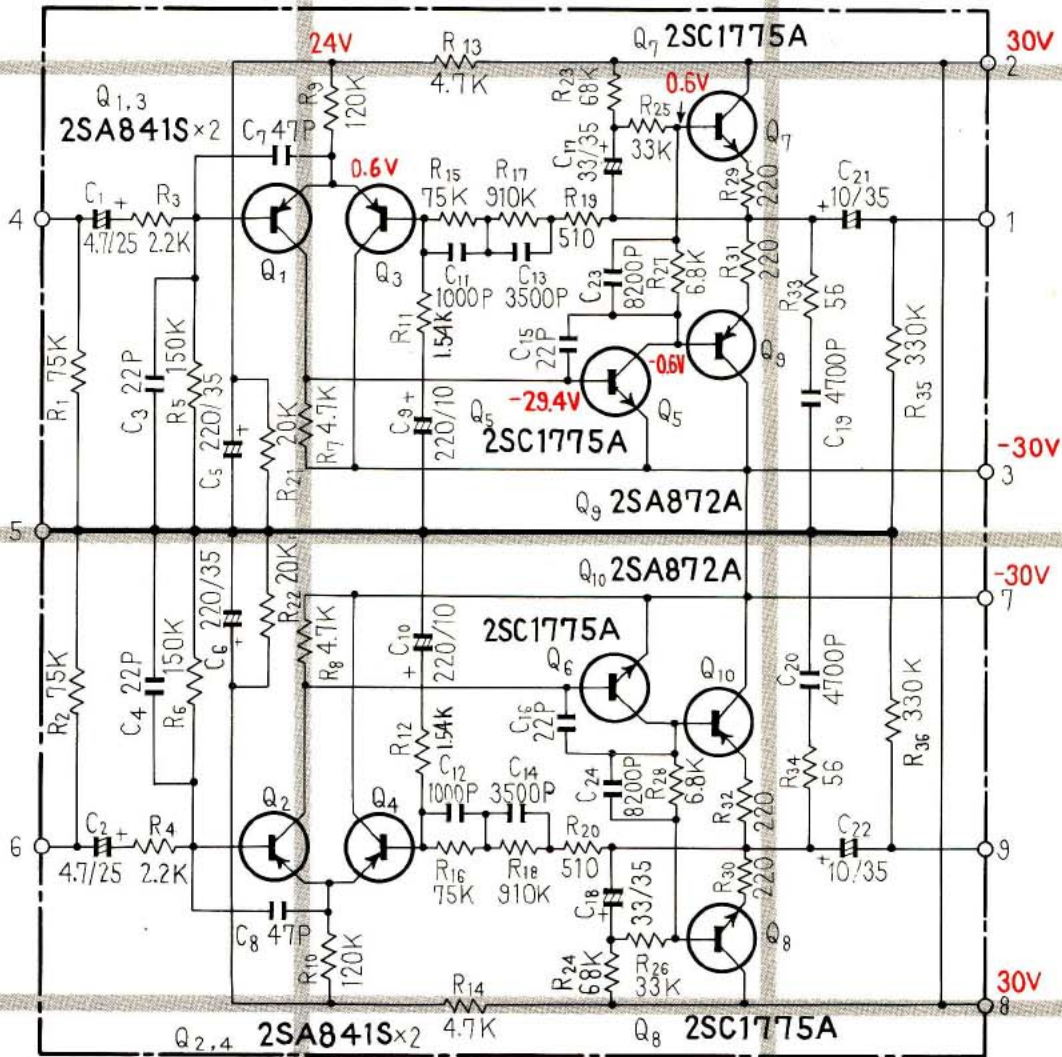

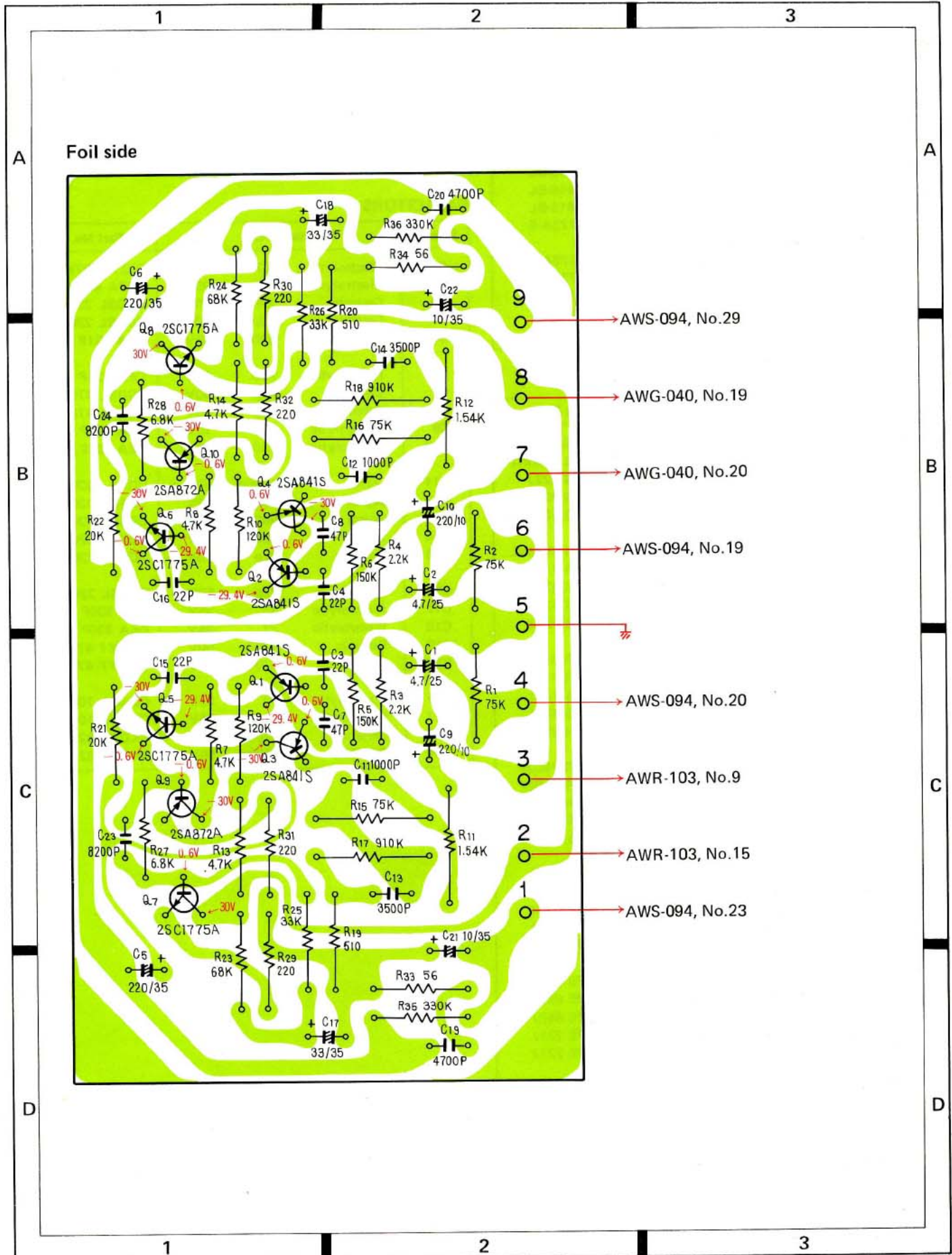

Foil side

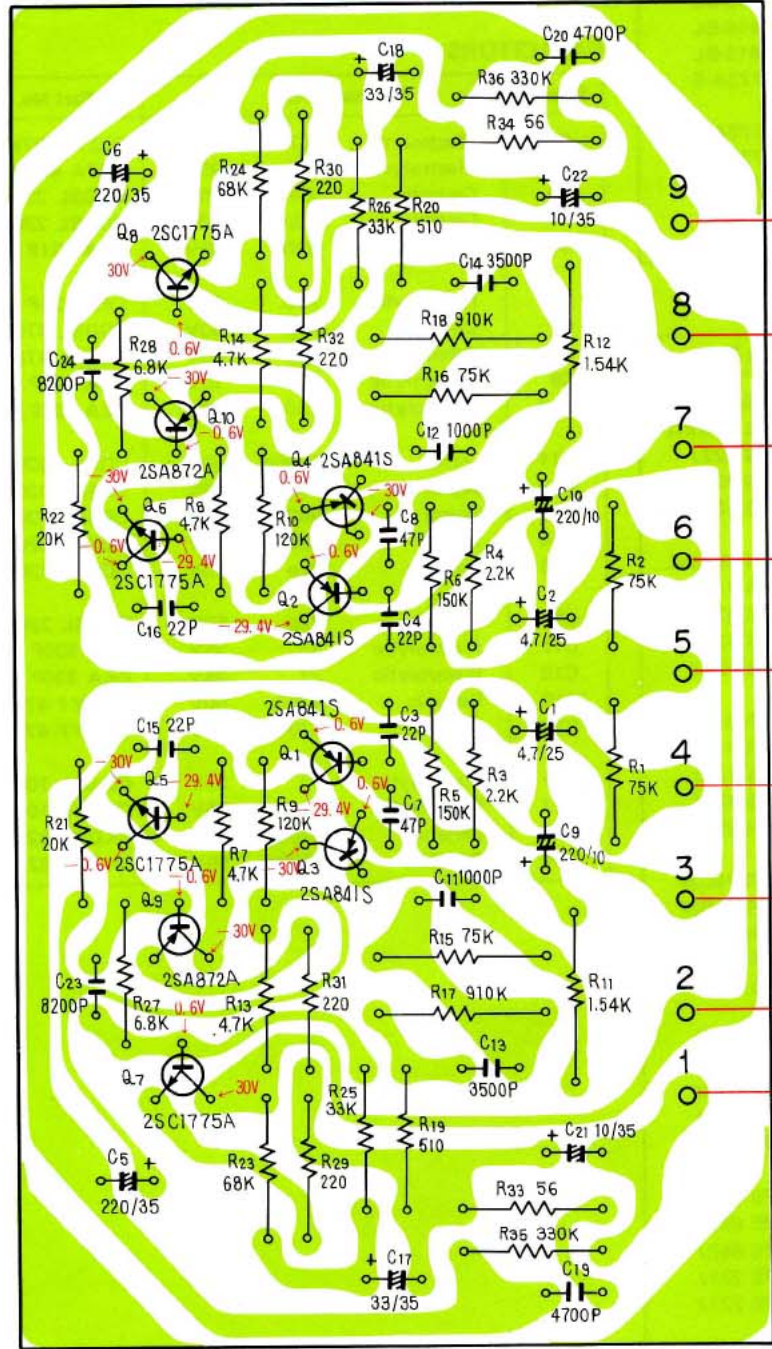

- 9 → AWS-094, No.29
- 8 → AWG-040, No.19
- 7 → AWG-040, No.20
- 6 → AWS-094, No.19
- 5 →
- 4 → AWS-094, No.20
- 3 → AWR-103, No.9
- 2 → AWR-103, No.15
- 1 → AWS-094, No.23

Parts List of Equalizer Amplifier Assembly (AWF-020)

SEMICONDUCTORS

Symbol	Description	Part No.
Q1	Transistor	2SA841S-BL
Q2	Transistor	2SA841S-BL
Q3	Transistor	2SA841S-BL
Q4	Transistor	2SA841S-BL
Q5	Transistor	2SC1775A-E
Q6	Transistor	2SC1775A-E
Q7	Transistor	2SC1775A-E
Q8	Transistor	2SC1775A-E
Q9	Transistor	2SA872A-E
Q10	Transistor	2SA872A-E

Symbol	Description	Part No.
R36	Carbon film 330k	RD¼PS 334J

CAPACITORS

Symbol	Description	Part No.
C1	Electrolytic 4.7 25V	CSZA 4R7M 25
C2	Electrolytic 4.7 25V	CSZA 4R7M 25
C3	Ceramic 22p 50V	CCDSL 220K 50
C4	Ceramic 22p 50V	CCDSL 220K 50
C5	Electrolytic 220 35V	CEA 221P 35
C6	Electrolytic 220 35V	CEA 221P 35
C7	Ceramic 47p 50V	CCDSL 470K 50
C8	Ceramic 47p 50V	CCDSL 470K 50
C9	Electrolytic 220 10V	CEA 221P 10
C10	Electrolytic 220 10V	CEA 221P 10
C11	Styrol 1000p 50V	CQSA 102G 50
C12	Styrol 1000p 50V	CQSA 102G 50
C13	Styrol 3500p 50V	CQSA 352G 50
C14	Styrol 3500p 50V	CQSA 352G 50
C15	Ceramic 22p 50V	CCDSL 220K 50
C16	Ceramic 22p 50V	CCDSL 220K 50
C17	Electrolytic 33 35V	CEA 330P 35
C18	Electrolytic 33 35V	CEA 330P 35
C19	Ceramic 4700p 50V	CKDYF 472K 50
C20	Ceramic 4700p 50V	CKDYF 472K 50
C21	Electrolytic 10 35V	CEANL 100P 35
C22	Electrolytic 10 35V	CEANL 100P 35
C23	Ceramic 8200p 50V	CKDYF 822K 50
C24	Ceramic 8200p 50V	CKDYF 822K 50

RESISTORS

Symbol	Description	Part No.
R1	Carbon film 75k	RD¼PS 753JNL
R2	Carbon film 75k	RD¼PS 753JNL
R3	Carbon film 2.2k	RD¼PS 222J
R4	Carbon film 2.2k	RD¼PS 222J
R5	Carbon film 150k	RD¼PS 154JNL
R6	Carbon film 150k	RD¼PS 154JNL
R7	Carbon film 4.7k	RD¼PS 472J
R8	Carbon film 4.7k	RD¼PS 472J
R9	Carbon film 120k	RD¼PS 124J
R10	Carbon film 120k	RD¼PS 124J
R11	Metal film 1.54k ¼W	RN½SR 1541F
R12	Metal film 1.54k ¼W	RN½SR 1541F
R13	Carbon film 4.7k	RD¼PS 472J
R14	Carbon film 4.7k	RD¼PS 472J
R15	Metal film 75k ¼W	RN½SR 7502F
R16	Metal film 75k ¼W	RN½SR 7502F
R17	Metal film 910k ¼W	RN½SR 9103F
R18	Metal film 910k ¼W	RN½SR 9103F
R19	Carbon film 510	RD¼PS 511J
R20	Carbon film 510	RD¼PS 511J
R21	Carbon film 20k	RD¼PS 203J
R22	Carbon film 20k	RD¼PS 203J
R23	Carbon film 68k	RD¼PS 683J
R24	Carbon film 68k	RD¼PS 683J
R25	Carbon film 33k	RD¼PS 333J
R26	Carbon film 33k	RD¼PS 333J
R27	Carbon film 6.8k	RD¼PS 682J
R28	Carbon film 6.8k	RD¼PS 682J
R29	Carbon film 220	RD¼PS 221J
R30	Carbon film 220	RD¼PS 221J
R31	Carbon film 220	RD¼PS 221J
R32	Carbon film 220	RD¼PS 221J
R33	Carbon film 56	RD¼PS 560J
R34	Carbon film 56	RD¼PS 560J
R35	Carbon film 330k	RD¼PS 334J

12.4 FUNCTION SWITCH ASSEMBLY (AWS-094)

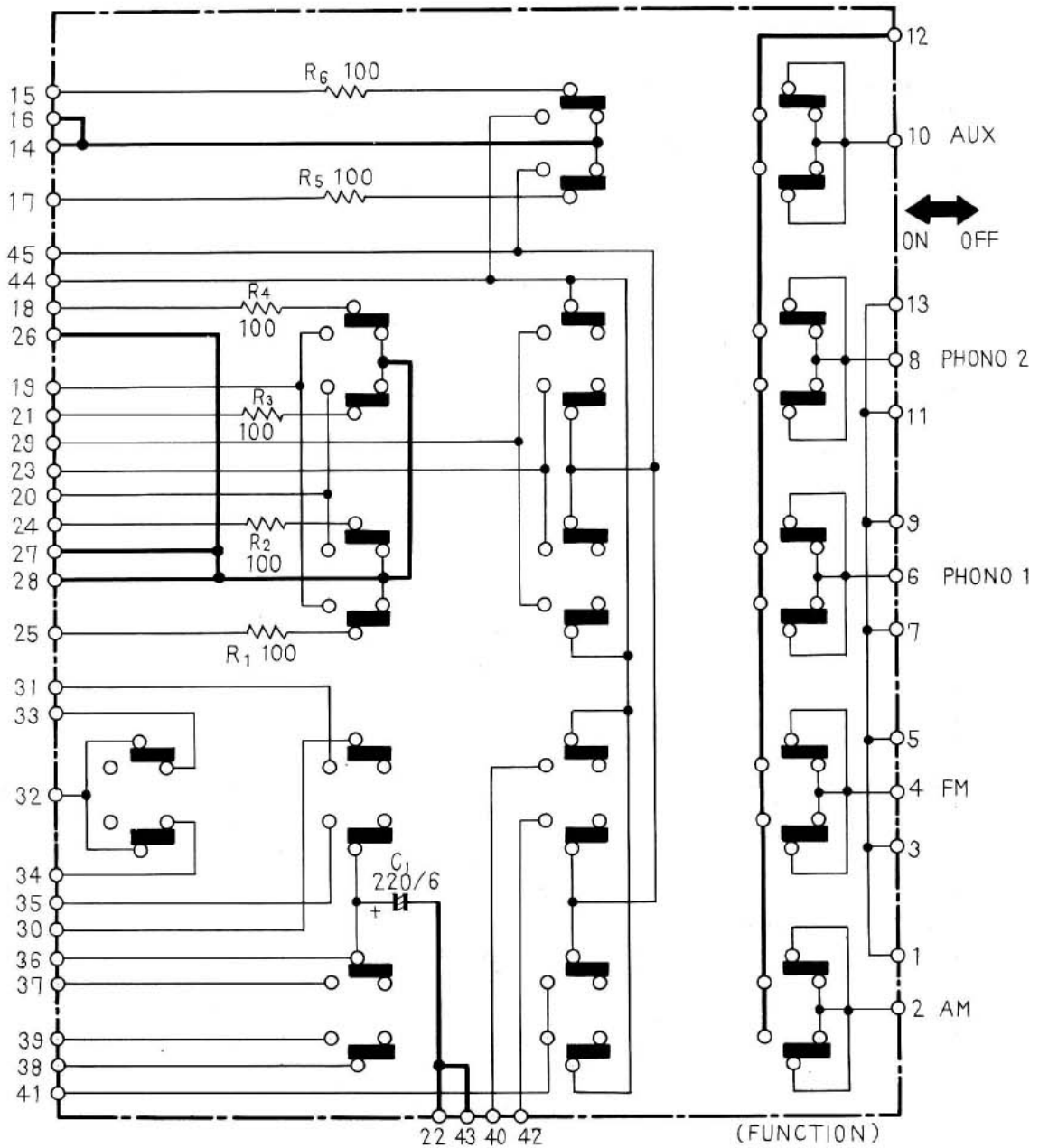

Parts List of Function Switch Assembly (AWS-094)

Symbol	Description	Part No.
S1	Push switch (FUNCTION)	ASG-095
R1	Carbon film resistor 100	RD½PS 101J
R2	Carbon film resistor 100	RD½PS 101J
R3	Carbon film resistor 100	RD½PS 101J
R4	Carbon film resistor 100	RD½PS 101J
R5	Carbon film resistor 100	RD½PS 101J
R6	Carbon film resistor 100	RD½PS 101J
C1	Electrolytic capacitor 220 6V	CEA 221P 6

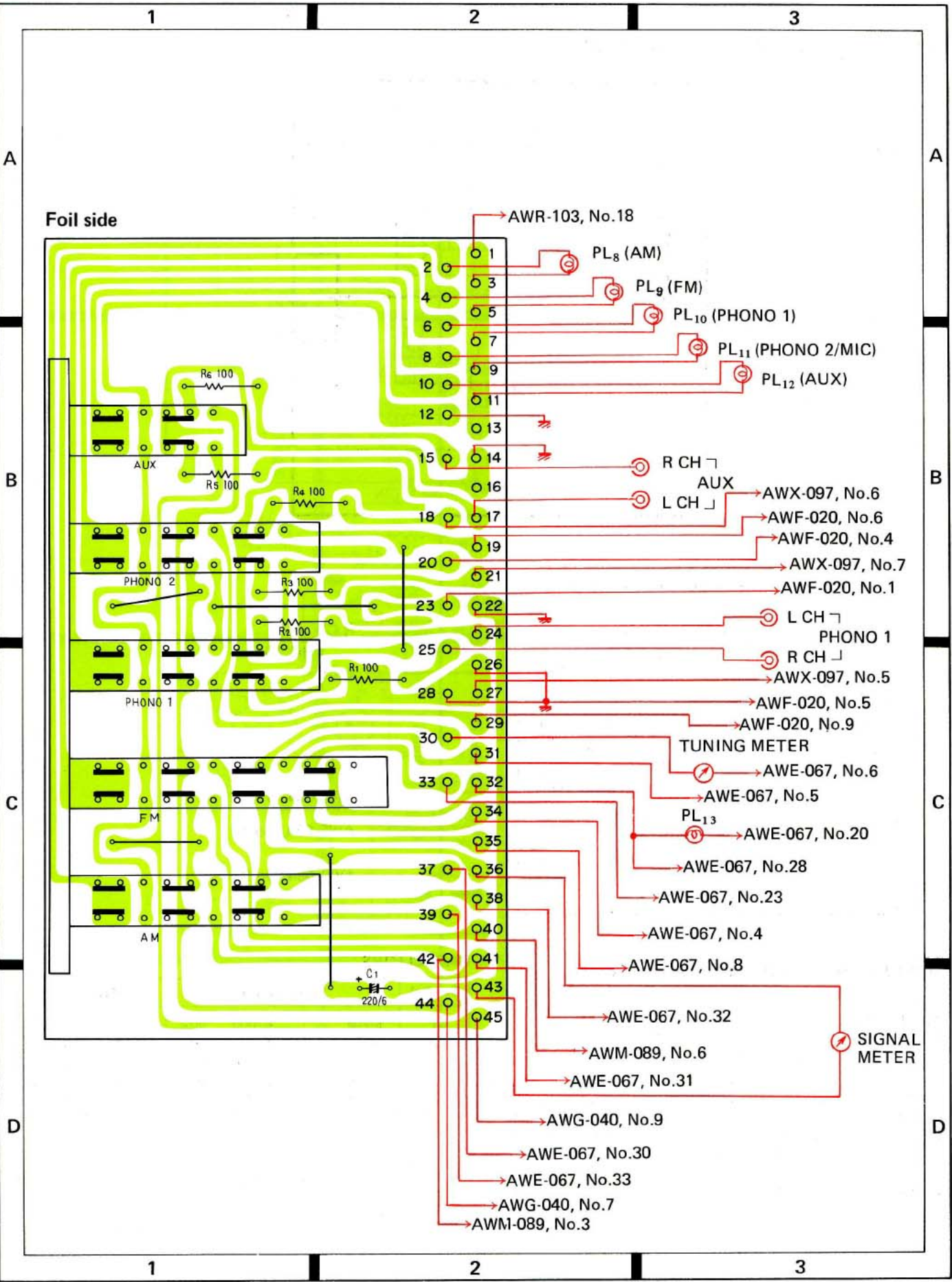

12.5 MIC JACK ASSEMBLY (AWX-097)

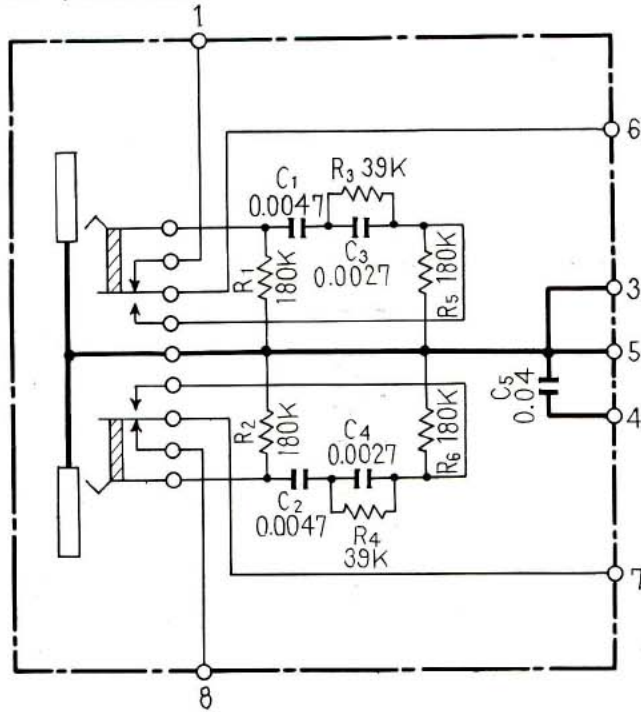

Foil side

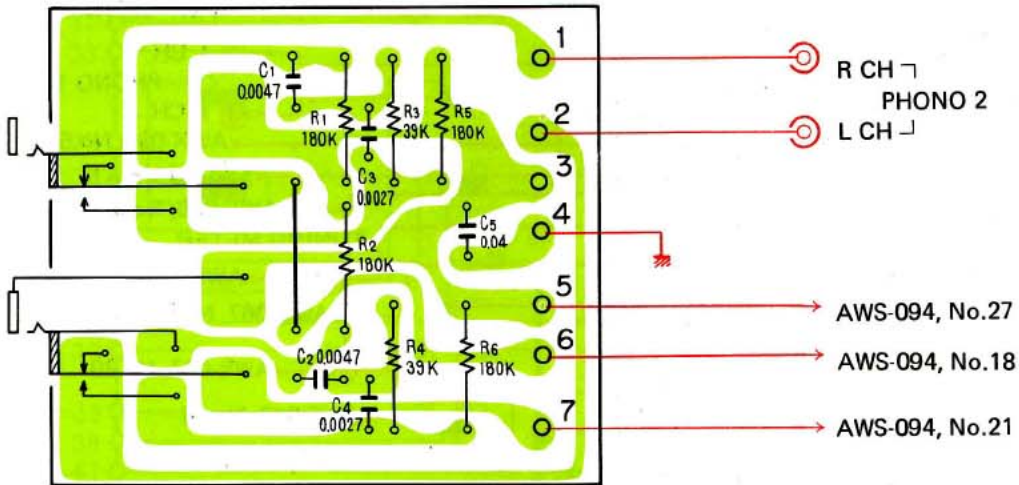

Parts List of Mic jack Assembly (AWX-097)

RESISTORS

Symbol	Description	Part No.
R1	Carbon film 180k	RD¼PS 184JNL
R2	Carbon film 180k	RD¼PS 184JNL
R3	Carbon film 39k	RD¼PS 393JNL
R4	Carbon film 39k	RD¼PS 393JNL
R5	Carbon film 180k	RD¼PS 184JNL
R6	Carbon film 180k	RD¼PS 184JNL

CAPACITORS

Symbol	Description	Part No.
C1	Mylar 4700p 50V	CQMA 472J 50
C2	Mylar 4700p 50V	CQMA 472J 50
C3	Mylar 2700p 50V	CQMA 272J 50
C4	Mylar 2700p 50V	CQMA 272J 50
C5	Ceramic 0.04	CKDYF 403Z 50

OTHER

Symbol	Description	Part No.
	Phone jack (MIC)	AKN-013

12.6 FLAT AMPLIFIER ASSEMBLY (AWG-040)

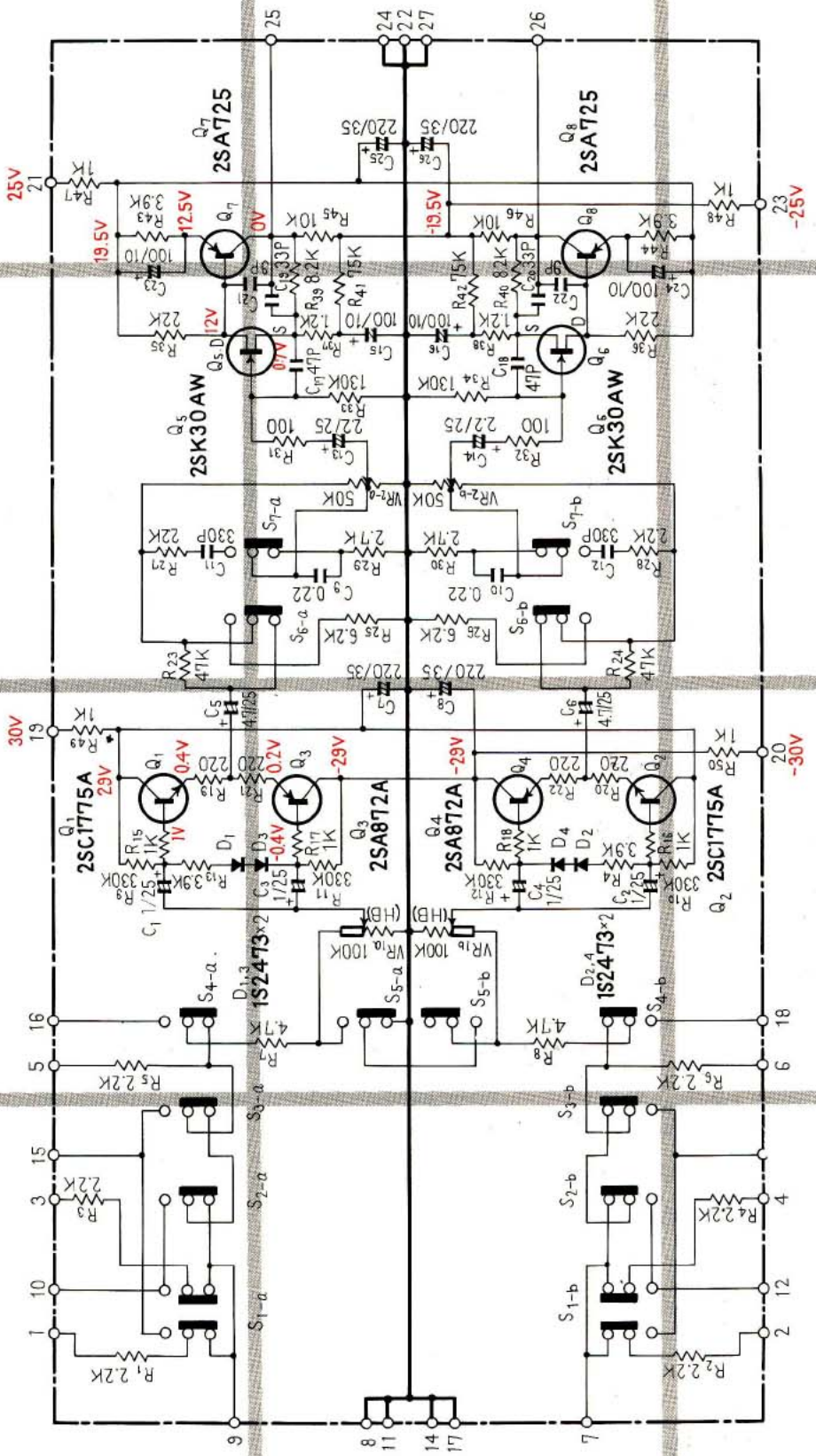

- S4 ADAPTOR
 - S5 MODE
 - S6 MUTING
 - S7 LOUDNESS
-
- S1 DUPLICATE
 - S2 MONITOR 1
 - S3 MONITOR 2

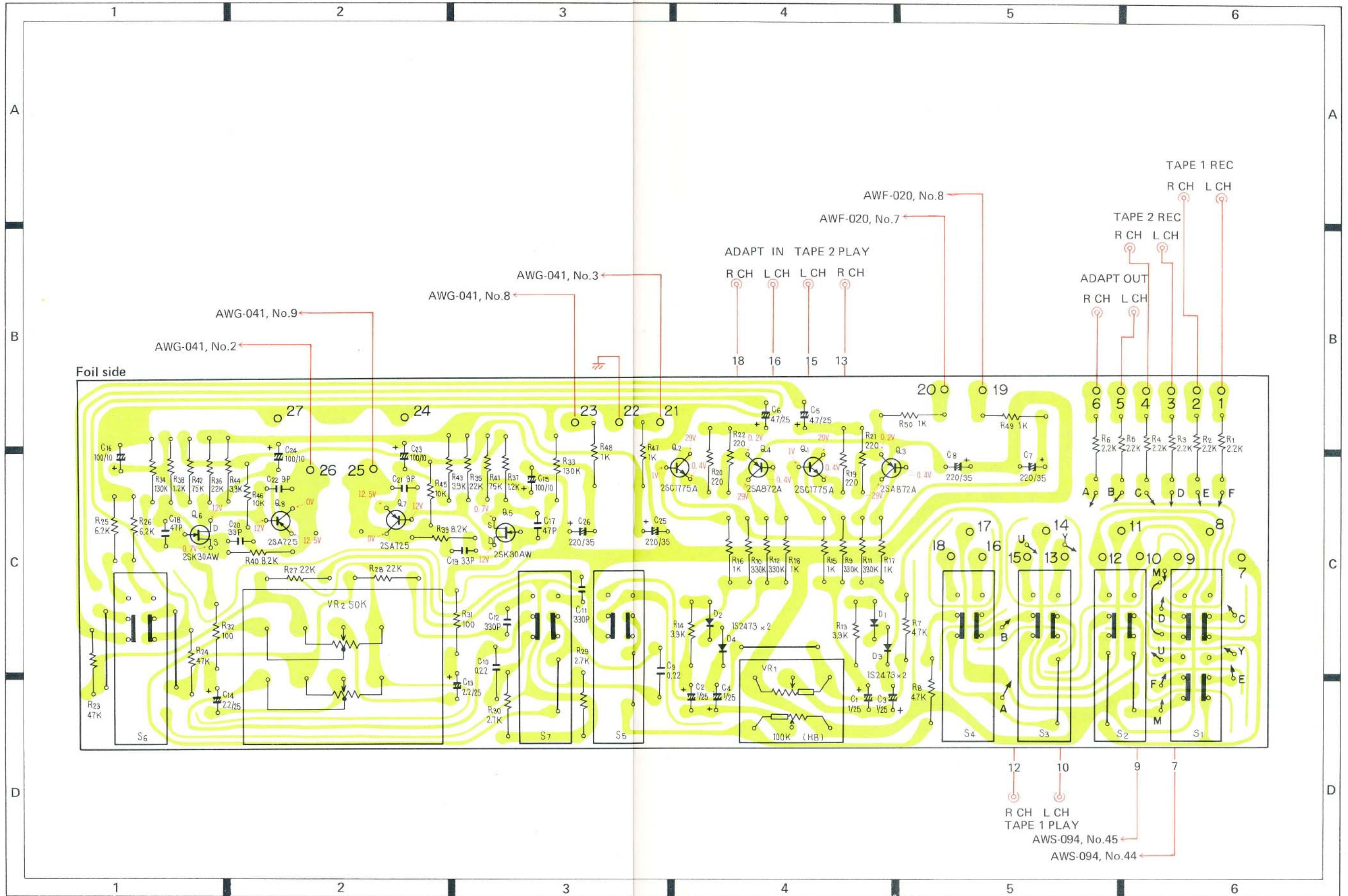

Parts List of Flat Amplifier Assembly (AWG-040)

SEMICONDUCTORS

Symbol	Description	Part No.
Q1	Transistor	2SC1775A-E
Q2	Transistor	2SC1775A-E
Q3	Transistor	2SA872A-E
Q4	Transistor	2SA872A-E
Q5	FET	2SK30AW-Y
Q6	FET	2SK30AW-Y
Q7	Transistor	2SA725-G
Q8	Transistor	2SA725-G
D1	Diode	1S2473
D2	Diode	1S2473
D3	Diode	1S2473
D4	Diode	1S2473

SWITCHES

Symbol	Description	Part No.
S1	Lever switch (DUPLICATE)	ASK-092-0
S2	Lever switch (TAPE MONITOR 1)	ASK-090-0
S3	Lever switch (TAPE MONITOR 2)	ASK-090-0
S4	Lever switch (ADAPTOR)	ASK-090-0
S5	Lever switch (MODE)	ASK-090-0
S6	Lever switch (MUTING)	ASK-090-0
S7	Lever switch (LOUDNESS)	ASK-090-0

RESISTORS AND POTENTIOMETERS

Symbol	Description	Part No.
VR1	Variable resistor (BALANCE) 100k-HB	ACV-163
VR2	Variable resistor (VOLUME) 50k	ACV-169
R1	Carbon film 2.2k	RD¼PS 222J
R2	Carbon film 2.2k	RD¼PS 222J
R3	Carbon film 2.2k	RD¼PS 222J
R4	Carbon film 2.2k	RD¼PS 222J
R5	Carbon film 2.2k	RD¼PS 222J
R6	Carbon film 2.2k	RD¼PS 222J
R7	Carbon film 4.7k	RD¼PS 472J
R8	Carbon film 4.7k	RD¼PS 472J
R9	Carbon film 330k	RD¼PS 334JNL
R10	Carbon film 330k	RD¼PS 334JNL
R11	Carbon film 330k	RD¼PS 334JNL
R12	Carbon film 330k	RD¼PS 334JNL
R13	Carbon film 3.9k	RD¼PS 392J
R14	Carbon film 3.9k	RD¼PS 392J
R15	Carbon film 1k	RD¼PS 102J
R16	Carbon film 1k	RD¼PS 102J
R17	Carbon film 1k	RD¼PS 102J

Symbol	Description	Part No.
R18	Carbon film 1k	RD¼PS 102J
R19	Carbon film 220	RD¼PS 221J
R20	Carbon film 220	RD¼PS 221J
R21	Carbon film 220	RD¼PS 221J
R22	Carbon film 220	RD¼PS 221J
R23	Carbon film 47k	RD¼PS 473J
R24	Carbon film 47k	RD¼PS 473J
R25	Carbon film 6.2k	RD¼PS 622J
R26	Carbon film 6.2k	RD¼PS 622J
R27	Carbon film 22k	RD¼PS 223J
R28	Carbon film 22k	RD¼PS 223J
R29	Carbon film 2.7k	RD¼PS 272J
R30	Carbon film 2.7k	RD¼PS 272J
R31	Carbon film 100	RD¼PS 101J
R32	Carbon film 100	RD¼PS 101J
R33	Carbon film 130k	RD¼PS 134JNL
R34	Carbon film 130k	RD¼PS 134JNL
R35	Carbon film 22k	RD¼PS 223J
R36	Carbon film 22k	RD¼PS 223J
R37	Carbon film 1.2k	RD¼PS 122J
R38	Carbon film 1.2k	RD¼PS 122J
R39	Carbon film 8.2k	RD¼PS 822J
R40	Carbon film 8.2k	RD¼PS 822J
R41	Carbon film 75k	RD¼PS 753J
R42	Carbon film 75k	RD¼PS 753J
R43	Carbon film 3.9k	RD¼PS 392J
R44	Carbon film 3.9k	RD¼PS 392J
R45	Carbon film 10k	RD¼PS 103J
R46	Carbon film 10k	RD¼PS 103J
R47	Carbon film 1k	RD¼PS 102J
R48	Carbon film 1k	RD¼PS 102J
R49	Carbon film 1k	RD¼PS 102J
R50	Carbon film 1k	RD¼PS 102J

CAPACITORS

Symbol	Description	Part No.
C1	Electrolytic 1 25V	CSZA 010M 25
C2	Electrolytic 1 25V	CSZA 010M 25
C3	Electrolytic 1 25V	CSZA 010M 25
C4	Electrolytic 1 25V	CSZA 010M 25
C5	Electrolytic 4.7 25V	CEANL 4R7P 25
C6	Electrolytic 4.7 25V	CEANL 4R7P 25
C7	Electrolytic 220 35V	CEA 221P 35
C8	Electrolytic 220 35V	CEA 221P 35
C9	Mylar 0.24 50V	CQMA 224J 50
C10	Mylar 0.24 50V	CQMA 224J 50

Symbol	Description			Part No.
C11	Ceramic	330p	50V	CKDYB 331K 50
C12	Ceramic	330p	50V	CKDYB 331K 50
C13	Electrolytic	2.2	25V	CSZA 2R2M 25
C14	Electrolytic	2.2	25V	CSZA 2R2M 25
C15	Electrolytic	100	10V	CEANL 101P 10
C16	Electrolytic	100	10V	CEANL 101P 10
C17	Ceramic	47p	50V	CCDSL 470K 50
C18	Ceramic	47p	50V	CCDSL 470K 50
C19	Ceramic	33p	50V	CCDSL 330K 50
C20	Ceramic	33p	50V	CCDSL 330K 50
C21	Ceramic	9p	50V	CCDSL 090F 50
C22	Ceramic	9p	50V	CCDSL 090F 50
C23	Electrolytic	100	10V	CEANL 101P 10
C24	Electrolytic	100	10V	CEANL 101P 10
C25	Electrolytic	220	35V	CEA 221P 35
C26	Electrolytic	220	35V	CEA 221P 35

OTHERS

Symbol	Description	Part No.
	Union nut	ABN-021
	Washer faced nut	ABN-024

12.7 5P CONNECTOR ASSEMBLY (AWX-062)

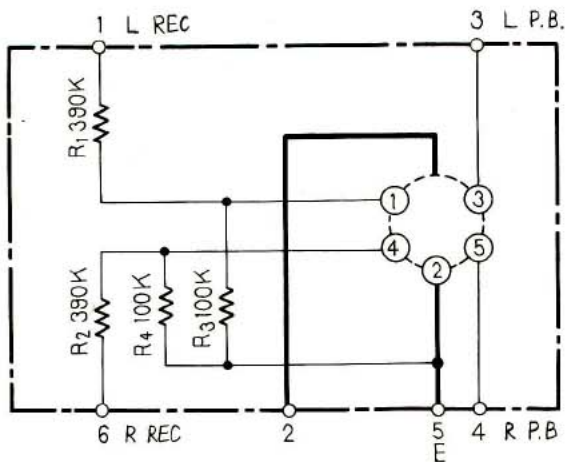

Foil side

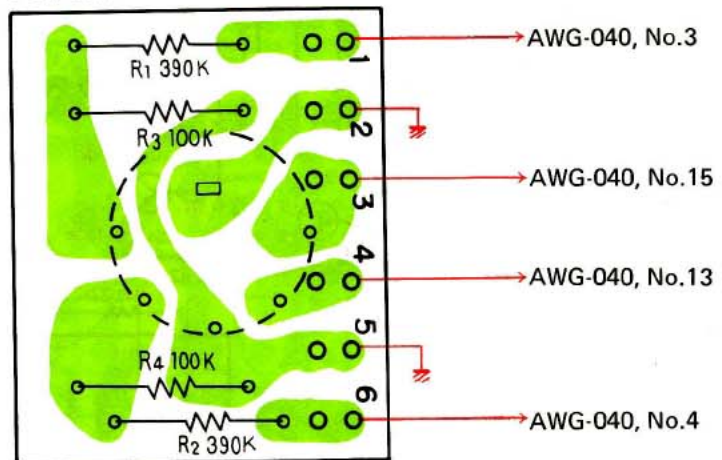

Parts List of 5P Connector Assembly (AWX-062)

Symbol	Description		Part No.
R1	Carbon film resistor	390k	RD $\frac{1}{4}$ PS 394J
R2	Carbon film resistor	390k	RD $\frac{1}{4}$ PS 394J
R3	Carbon film resistor	100k	RD $\frac{1}{4}$ PS 104J
R4	Carbon film resistor	100k	RD $\frac{1}{4}$ PS 104J
	REC-PB connector socket 5P		AKP-007

12.8 CONTROL AMPLIFIER ASSEMBLY (AWG-041)

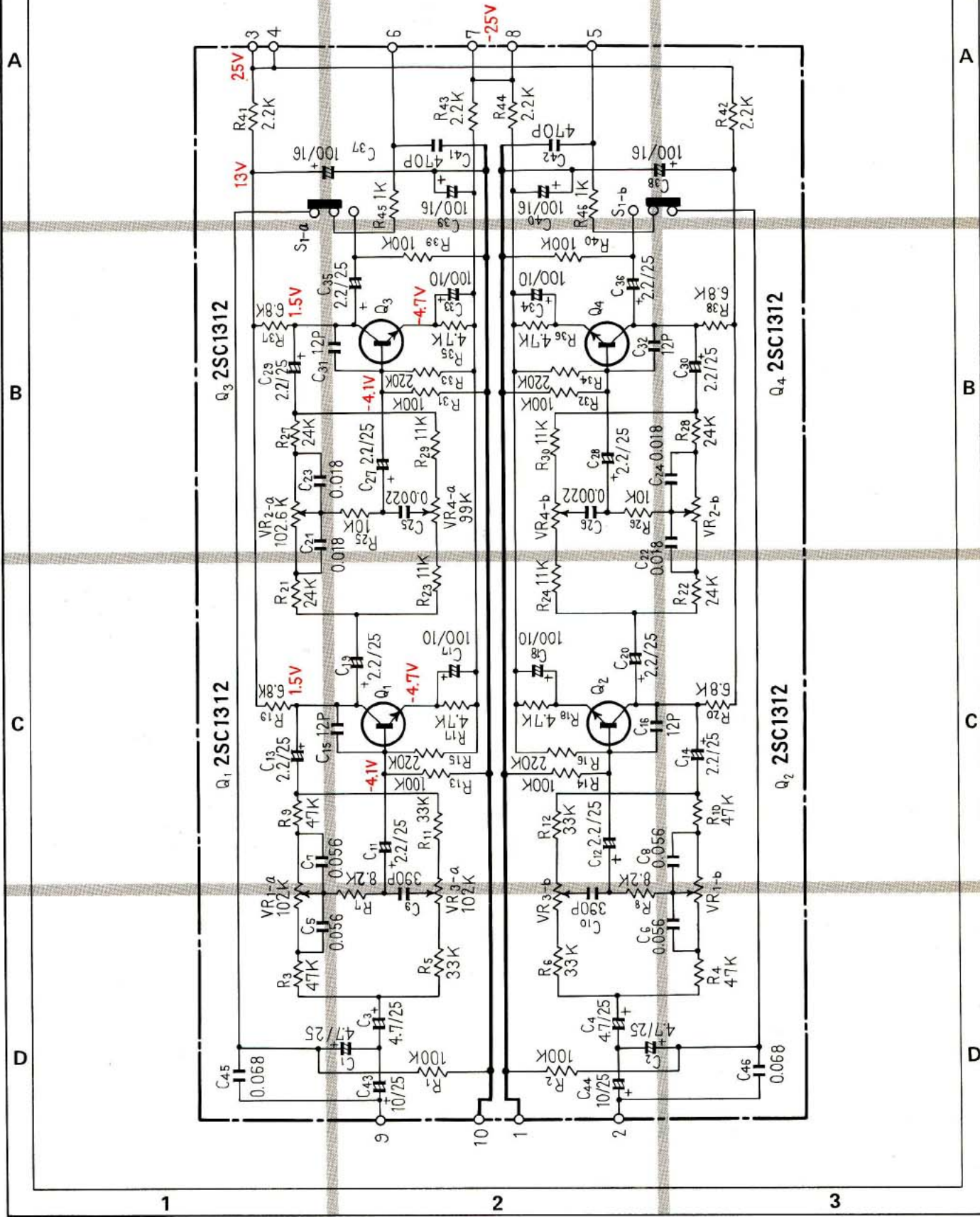

1

2

3

Foil side

AWG-040, No.25

AWG-040, No.23

AWM-089, No.11

AWM-089, No.18

AWM-089, No.16

AWM-089, No.14

AWG-040, No.21

AWG-040, No.26

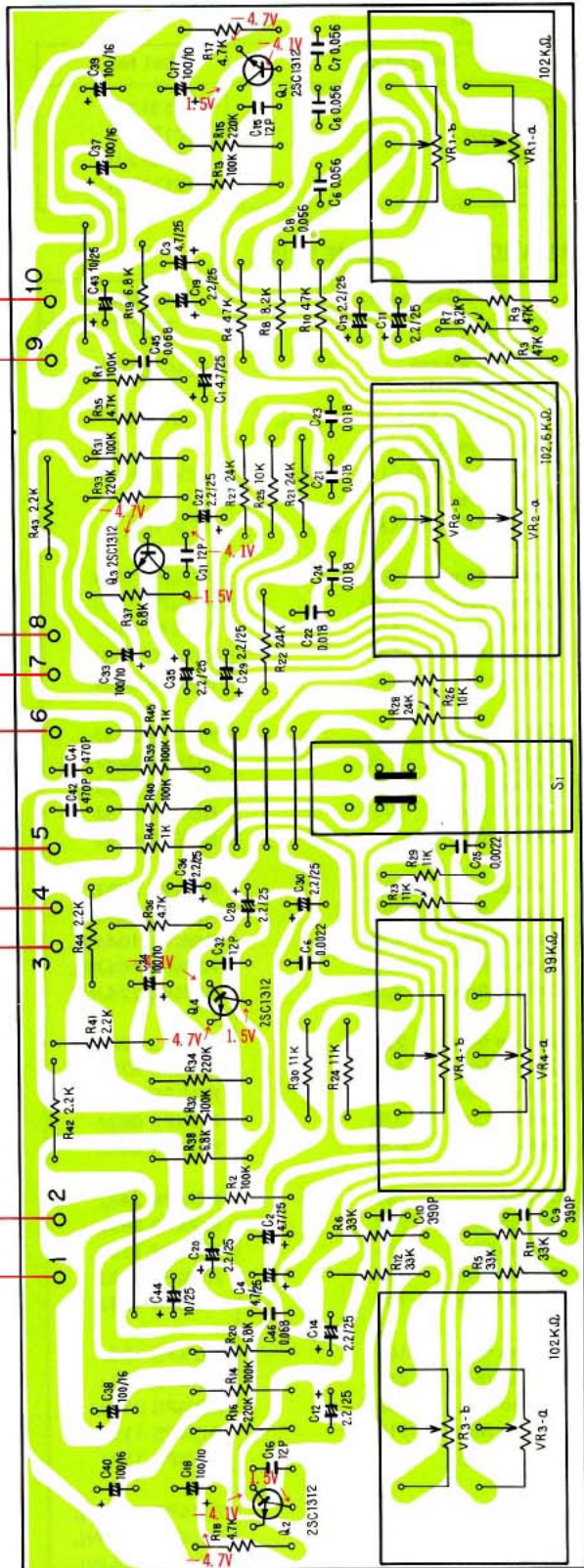

A

A

B

B

C

C

D

D

1

2

3

Parts List of Control Amplifier Assembly (AWG-041)

SEMICONDUCTORS

Symbol	Description	Part No.
Q1	Transistor	2SC1312-G
Q2	Transistor	2SC1312-G
Q3	Transistor	2SC1312-G
Q4	Transistor	2SC1312-G

RESISTORS AND POTENTIOMETERS

Symbol	Description	Part No.
VR1	Variable resistor (SUB BASS) 102k	ACV-165
VR2	Variable resistor (MAIN BASS) 102.6k	ACV-166
VR3	Variable resistor (SUB TREBLE) 102k	ACV-168
VR4	Variable resistor (MAIN TREBLE) 99k	ACV-167
R1	Carbon film 100k	RD%PS 104J
R2	Carbon film 100k	RD%PS 104J
R3	Carbon film 47k	RD%PS 473J
R4	Carbon film 47k	RD%PS 473J
R5	Carbon film 33k	RD%PS 333J
R6	Carbon film 33k	RD%PS 333J
R7	Carbon film 8.2k	RD%PS 822J
R8	Carbon film 8.2k	RD%PS 822J
R9	Carbon film 47k	RD%PS 473J
R10	Carbon film 47k	RD%PS 473J
R11	Carbon film 33k	RD%PS 333J
R12	Carbon film 33k	RD%PS 333J
R13	Carbon film 100k	RD%PS 104JNL
R14	Carbon film 100k	RD%PS 104JNL
R15	Carbon film 220k	RD%PS 224JNL
R16	Carbon film 220k	RD%PS 224JNL
R17	Carbon film 4.7k	RD%PS 472J
R18	Carbon film 4.7k	RD%PS 472J
R19	Carbon film 6.8k	RD%PS 682J
R20	Carbon film 6.8k	RD%PS 682J
R21	Carbon film 24k	RD%PS 243J
R22	Carbon film 24k	RD%PS 243J
R23	Carbon film 11k	RD%PS 113J
R24	Carbon film 11k	RD%PS 113J
R25	Carbon film 10k	RD%PS 103J
R26	Carbon film 10k	RD%PS 103J
R27	Carbon film 24k	RD%PS 243J
R28	Carbon film 24k	RD%PS 243J
R29	Carbon film 11k	RD%PS 113J
R30	Carbon film 11k	RD%PS 113J
R31	Carbon film 100k	RD%PS 104JNL
R32	Carbon film 100k	RD%PS 104JNL
R33	Carbon film 220k	RD%PS 224JNL

Symbol	Description	Part No.
R34	Carbon film 220k	RD%PS 224JNL
R35	Carbon film 4.7k	RD%PS 472J
R36	Carbon film 4.7k	RD%PS 472J
R37	Carbon film 6.8k	RD%PS 682J
R38	Carbon film 6.8k	RD%PS 682J
R39	Carbon film 100k	RD%PS 104J
R40	Carbon film 100k	RD%PS 104J
R41	Carbon film 2.2k	RD%PS 222J
R42	Carbon film 2.2k	RD%PS 222J
R43	Carbon film 2.2k	RD%PS 222J
R44	Carbon film 2.2k	RD%PS 222J
R45	Carbon film 1k	RD%PS 102J
R46	Carbon film 1k	RD%PS 102J

CAPACITORS

Symbol	Description	Part No.
C1	Electrolytic 4.7 25V	CSZA 4R7M 25
C2	Electrolytic 4.7 25V	CSZA 4R7M 25
C3	Electrolytic 4.7 25V	CSZA 4R7M 25
C4	Electrolytic 4.7 25V	CSZA 4R7M 25
C5	Mylar 0.056 50V	CQMA 563J 50
C6	Mylar 0.056 50V	CQMA 563J 50
C7	Mylar 0.056 50V	CQMA 563J 50
C8	Mylar 0.056 50V	CQMA 563J 50
C9	Styrol 390p 50V	CQSA 391J 50
C10	Styrol 390p 50V	CQSA 391J 50
C11	Electrolytic 2.2 25V	CEANL 2R2P 25
C12	Electrolytic 2.2 25V	CEANL 2R2P 25
C13	Electrolytic 2.2 25V	CEANL 2R2P 25
C14	Electrolytic 2.2 25V	CEANL 2R2P 25
C15	Ceramic 12p 50V	CCDSL 120K 50
C16	Ceramic 12p 50V	CCDSL 120K 50
C17	Electrolytic 100 16V	ACH-312
C18	Electrolytic 100 16V	ACH-312
C19	Electrolytic 2.2 25V	CEANL 2R2P 25
C20	Electrolytic 2.2 25V	CEANL 2R2P 25
C21	Mylar 0.018 50V	CQMA 183J 50
C22	Mylar 0.018 50V	CQMA 183J 50
C23	Mylar 0.018 50V	CQMA 183J 50
C24	Mylar 0.018 50V	CQMA 183J 50
C25	Ceramic 2200p 50V	CKDYA 222J 50
C26	Ceramic 2200p 50V	CKDYA 222J 50
C27	Electrolytic 2.2 25V	CEANL 2R2P 25
C28	Electrolytic 2.2 25V	CEANL 2R2P 25
C29	Electrolytic 2.2 25V	CEANL 2R2P 25
C30	Electrolytic 2.2 25V	CEANL 2R2P 25

Symbol	Description			Part No.
C31	Ceramic	12p	50V	CCDSL 120K 50
C32	Ceramic	12p	50V	CCDSL 120K 50
C33	Electrolytic	100	10V	ACH-312
C34	Electrolytic	100	10V	ACH-312
C35	Electrolytic	2.2	25V	CEANL 2R2P 25
C36	Electrolytic	2.2	25V	CEANL 2R2P 25
C37	Electrolytic	100	16V	ACH-311
C38	Electrolytic	100	16V	ACH-311
C39	Electrolytic	100	16V	ACH-311
C40	Electrolytic	100	16V	ACH-311
C41	Ceramic	470p	50V	CKDYB 471K 50
C42	Ceramic	470p	50V	CKDYB 471K 50
C43	Electrolytic	10	25V	CSZA 100M 25
C44	Electrolytic	10	25V	CSZA 100M 25
C45	Mylar	0.063	50V	CQMA 683J 50
C46	Mylar	0.063	50V	CQMA 683J 50

OTHERS

Symbol	Description	Part No.
	Lever switch (TONE)	ASK-090
	Washer faced nut	ABN-024

12.9 DE-EMPHASIS SWITCH ASSEMBLY (AWX-099)

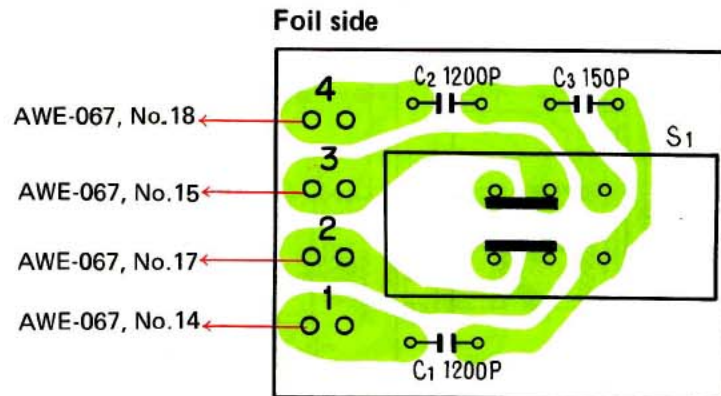
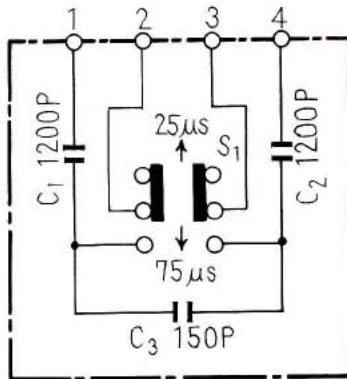

Parts List of De-emphasis Switch Assembly (AWX-099)

CAPACITORS

Symbol	Description			Part No.
C1	Mylar	1200p	50V	CQMA 122J 50
C2	Mylar	1200p	50V	CQMA 122J 50
C3	Mylar	150p	50V	CCDSL 151K 50

SWITCH

Symbol	Description	Part No.
S1	Slide switch	ASH-015-0

12.10 FILTER AMPLIFIER ASSEMBLY (AWM-089)

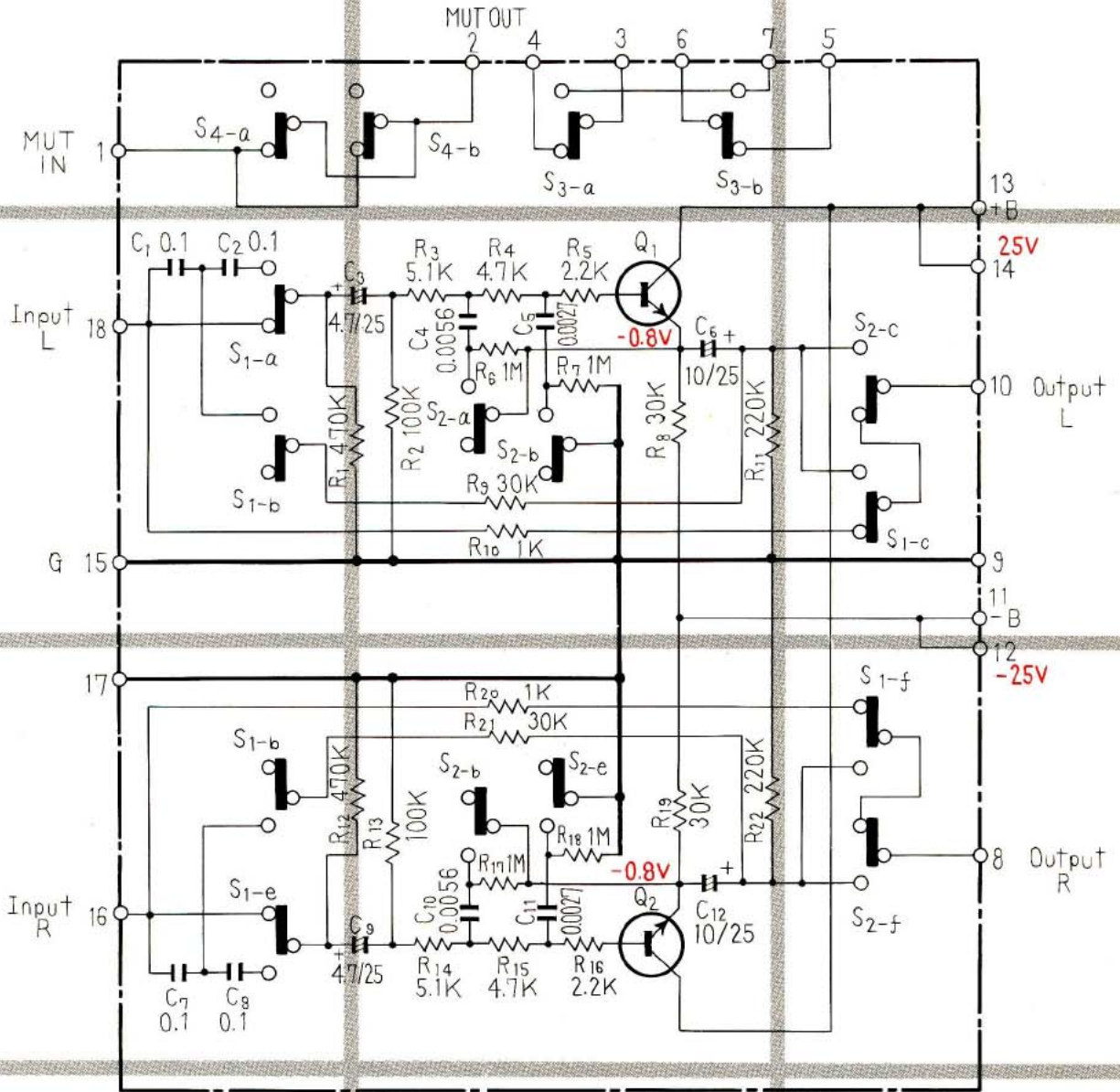

SWITCHES

- S₁ : LOW FILTER
- S₂ : HIGH FILTER
- S₃ : MULTIPATH
- S₄ : FM MUTING

TRANSISTORS

- Q₁, Q₂ **2SC1313** × 2
(**2SC1345**)

1

2

3

A

A

B

B

C

C

D

D

Foil side

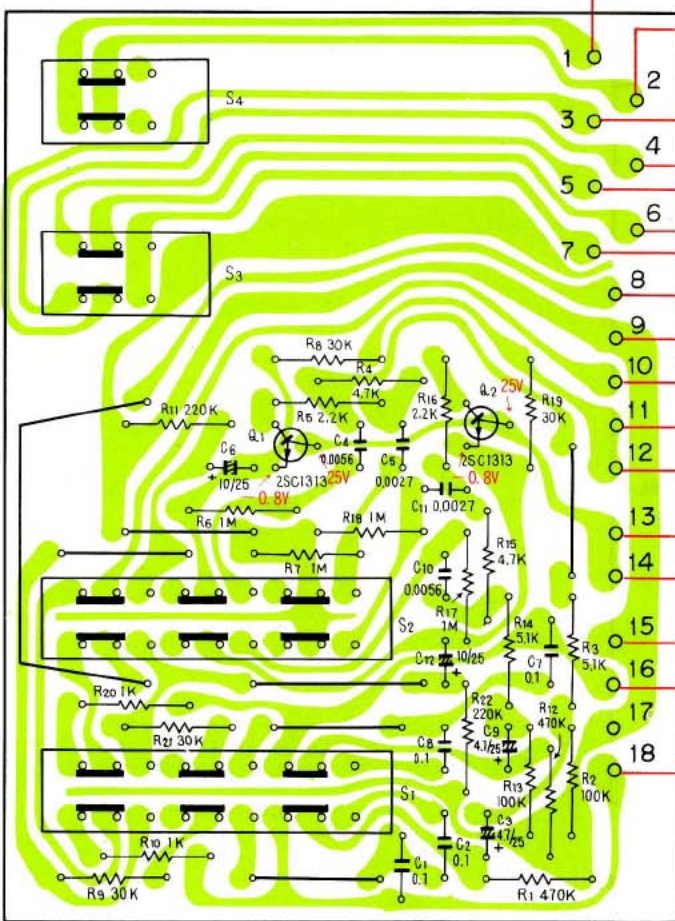

- AWE-067, No.9
- AWE-067, No.26
- AWS-094, No.42
- AWE-067, No.11
- AWE-067, No.13
- AWS-094, No.40
- AWE-067, No.7
- PRE OUT (R CH)
- AWH-047, Nos.9,11
- PRE OUT (L CH)
- AWG-041, No.7
- AWR-103, No.10
- AWR-103, No.14
- AWG-041, No.4
- AWR-103, No.14
- AWG-041, No.5
- AWG-041, No.6

1

2

3

Parts List of Filter Amplifier Assembly (AWM-089)

SEMICONDUCTORS

Symbol	Description	Part No.
Q1	Transistor	2SC1313-G
Q2	Transistor	2SC1313-G

Symbol	Description	Part No.
C8	Mylar 0.1 50V	CQMA 104J 50
C9	Electrolytic 4.7 25V	CSZA 4R7M 25
C10	Ceramic 5600p 50V	CKDYA 562J 50
C11	Ceramic 2700p 50V	CKDYA 272J 50
C12	Electrolytic 10 25V	CSZA 100M 25

SWITCHES

Symbol	Description	Part No.
S1~S4	Push switch (LOW FILTER, HIGH FILTER, MULTIPATH, FM MUTING)	ASG-098

RESISTORS

Symbol	Description	Part No.
R1	Carbon film 470k	RD%PS 474J
R2	Carbon film 100k	RD%PS 104JNL
R3	Carbon film 5.1k	RD%PS 512J
R4	Carbon film 4.7k	RD%PS 472J
R5	Carbon film 2.2k	RD%PS 222J
R6	Carbon film 1M	RD%PS 105J
R7	Carbon film 1M	RD%PS 105J
R8	Carbon film 30k	RD%PS 303J
R9	Carbon film 30k	RD%PS 303J
R10	Carbon film 1k	RD%PS 102J
R11	Carbon film 220k	RD%PS 224J
R12	Carbon film 470k	RD%PS 474J
R13	Carbon film 100k	RD%PS 104JNL
R14	Carbon film 5.1k	RD%PS 512J
R15	Carbon film 4.7k	RD%PS 472J
R16	Carbon film 2.2k	RD%PS 222J
R17	Carbon film 1M	RD%PS 105J
R18	Carbon film 1M	RD%PS 105J
R19	Carbon film 30k	RD%PS 303J
R20	Carbon film 1k	RD%PS 102J
R21	Carbon film 30k	RD%PS 303J
R22	Carbon film 220k	RD%PS 224J

CAPACITORS

Symbol	Description	Part No.
C1	Mylar 0.1 50V	CQMA 104J 50
C2	Mylar 0.1 50V	CQMA 104J 50
C3	Electrolytic 4.7 25V	CSZA 4R7M 25
C4	Ceramic 5600p 50V	CKDYA 562J 50
C5	Ceramic 2700p 50V	CKDYA 272J 50
C6	Electrolytic 10 25V	CSZA 100M 25
C7	Mylar 0.1 50V	CQMA 104J 50

12.11 POWER AMPLIFIER ASSEMBLY (AWH-047)

TRANSISTORS

- Q₁₋₆ 2SA750X6
- Q₇₋₁₀ 2SC1439X4
- Q_{11,21,22} 2SA858X4
- Q_{13,14} 2SA858X2
- Q_{15,16} 2SC1439X2
- Q_{19,20} 2SD381AX2
- Q_{17,18} 2SB536AX2
- Q_{23,24} 2SB539CX4
- Q_{25,26} 2SD287CX4

DIODES

- D₉₋₂₀ S1B01-02 or 1S1886 x12
- D_{3,4} 1S2473X2
- D₅₋₈ STV3HX4

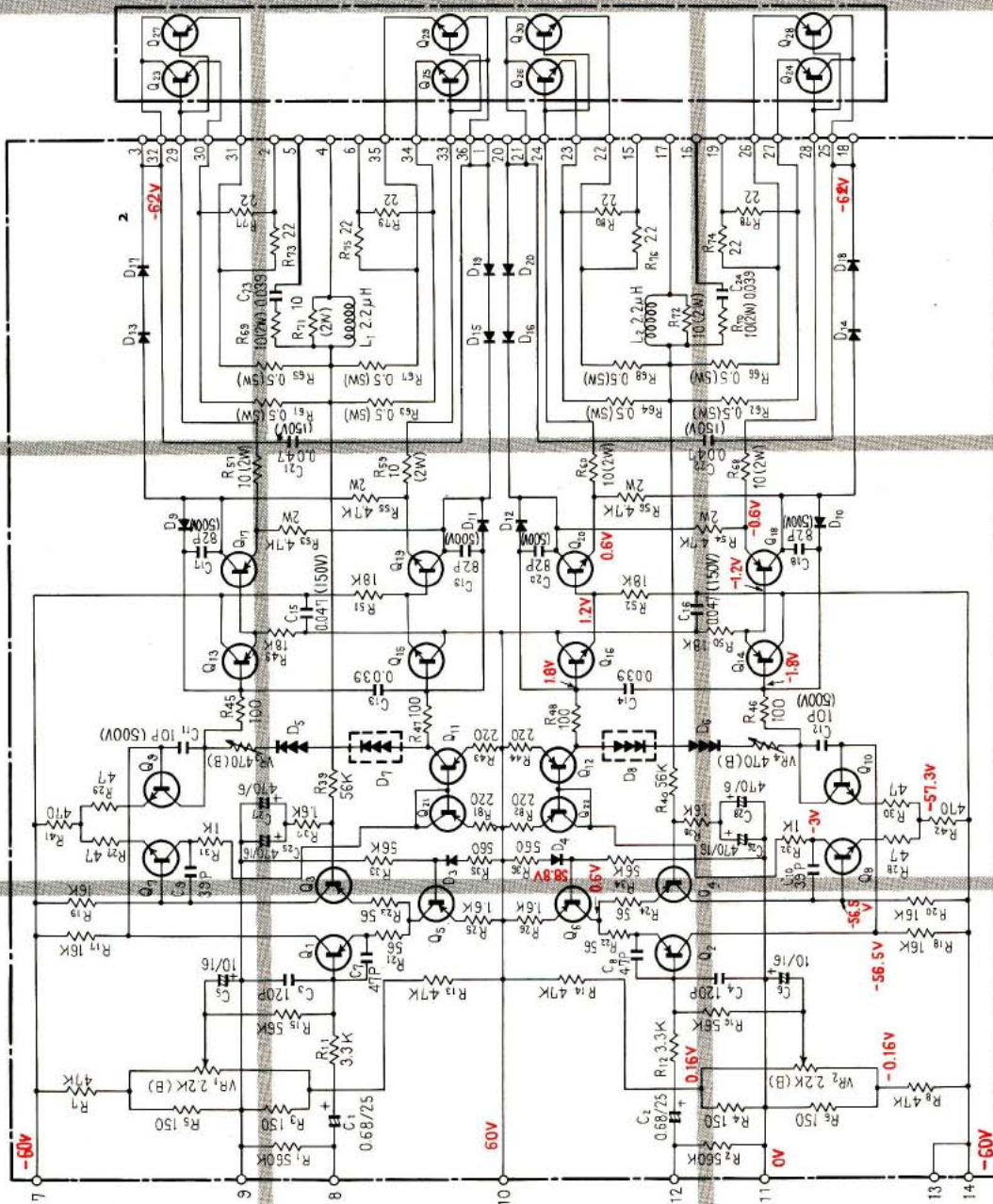

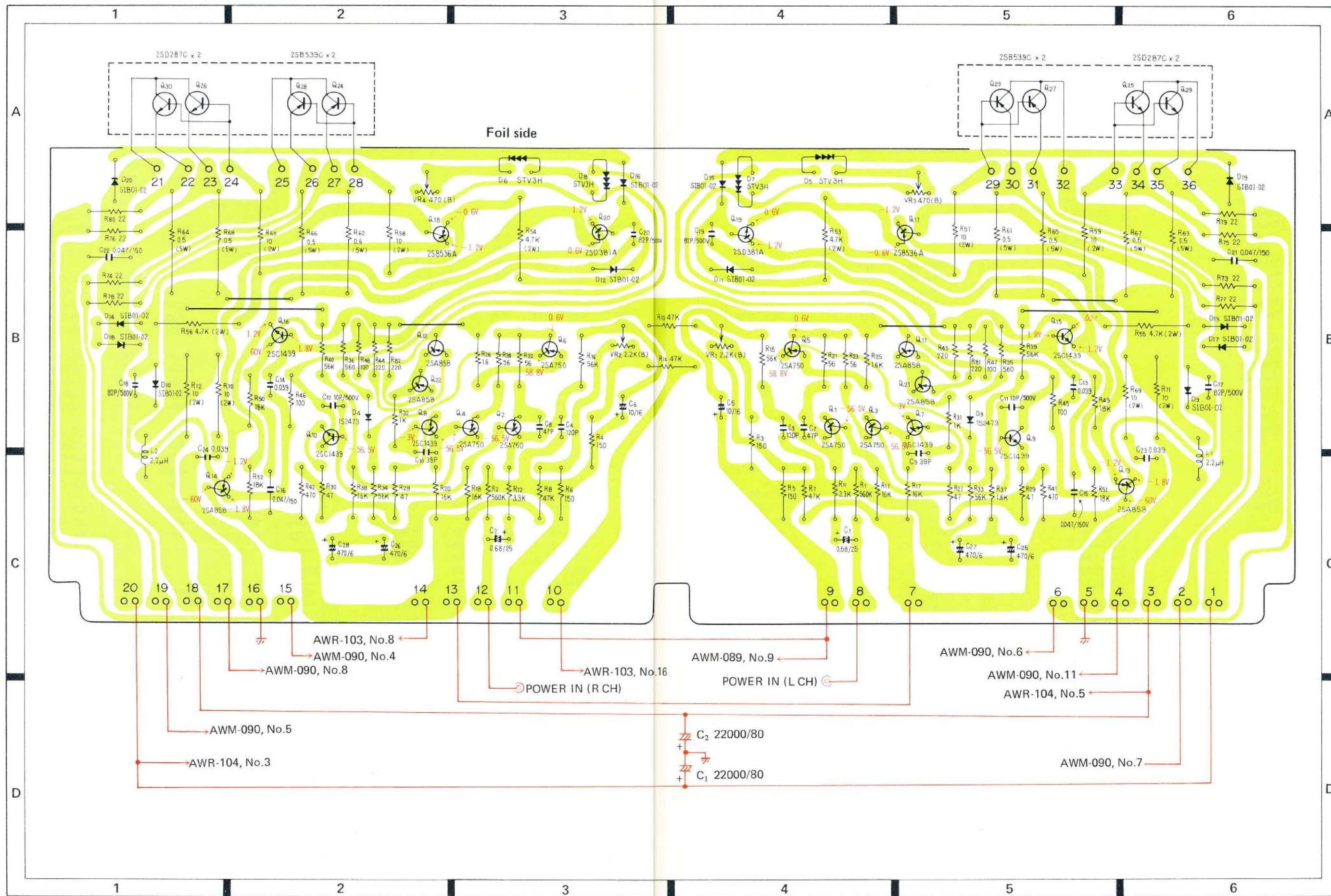

Parts List of Power Amplifier Assembly (AWH-047)

SEMICONDUCTORS

Symbol	Description	Part No.
Q1	Transistor	2SA750-E
Q2	Transistor	2SA750-E
Q3	Transistor	2SA750-E
Q4	Transistor	2SA750-E
Q5	Transistor	2SA750-E
Q6	Transistor	2SA750-E
Q7	Transistor	2SC1439-B
Q8	Transistor	2SC1439-B
Q9	Transistor	2SC1439-B
Q10	Transistor	2SC1439-B
Q11	Transistor	2SA858-B
Q12	Transistor	2SA858-B
Q13	Transistor	2SA858-B
Q14	Transistor	2SA858-B
Q15	Transistor	2SC1439-B
Q16	Transistor	2SC1439-B
Q17	Transistor	2SB536A-H
Q18	Transistor	2SB536A-H
Q19	Transistor	2SD381A-H
Q20	Transistor	2SD381A-H
Q21	Transistor	2SA858-B
Q22	Transistor	2SA858-B
D1
D2
D3	Diode	1S2473
D4	Diode	1S2473
D5	Varistor	STV3H
D6	Varistor	STV3H
D7	Varistor	STV3H
D8	Varistor	STV3H
D9	Diode	SIB01-02
D10	Diode	SIB01-02
D11	Diode	SIB01-02
D12	Diode	SIB01-02
D13	Diode	SIB01-02
D14	Diode	SIB01-02
D15	Diode	SIB01-02
D16	Diode	SIB01-02
D17	Diode	SIB01-02
D18	Diode	SIB01-02
D19	Diode	SIB01-02
D20	Diode	SIB01-02

RESISTORS

Symbol	Description	Part No.
R1	Carbon film 560k	RD¼PS 564J
R2	Carbon film 560k	RD¼PS 564J
R3	Carbon film 150	RD¼PS 151J
R4	Carbon film 150	RD¼PS 151J
R5	Carbon film 150	RD¼PS 151J
R6	Carbon film 150	RD¼PS 151J
R7	Carbon film 47k	RD¼PS 473J
R8	Carbon film 47k	RD¼PS 473J
R9
R10
R11	Carbon film 3.3k	RD¼PS 332J
R12	Carbon film 3.3k	RD¼PS 332J
R13	Carbon film 47k	RD¼PS 473J
R14	Carbon film 47k	RD¼PS 473J
R15	Carbon film 56k	RD¼PS 563J
R16	Carbon film 56k	RD¼PS 563J
R17	Carbon film 16k	RD¼PS 163J
R18	Carbon film 16k	RD¼PS 163J
R19	Carbon film 16k	RD¼PS 163J
R20	Carbon film 16k	RD¼PS 163J
R21	Carbon film 56	RD¼PS 560J
R22	Carbon film 56	RD¼PS 560J
R23	Carbon film 56	RD¼PS 560J
R24	Carbon film 56	RD¼PS 560J
R25	Carbon film 1.6k	RD¼PS 162J
R26	Carbon film 1.6k	RD¼PS 162J
R27	Carbon film 47	RD¼PS 470J
R28	Carbon film 47	RD¼PS 470J
R29	Carbon film 47	RD¼PS 470J
R30	Carbon film 47	RD¼PS 470J
R31	Carbon film 1k	RD¼PS 102J
R32	Carbon film 1k	RD¼PS 102J
R33	Carbon film 56k	RD¼PS 563J
R34	Carbon film 56k	RD¼PS 563J
R35	Carbon film 560	RD¼PS 561J
R36	Carbon film 560	RD¼PS 561J
R37	Carbon film 1.6k	RD¼PS 162J
R38	Carbon film 1.6k	RD¼PS 162J

Symbol	Description	Part No.
R39	Carbon film 56k	RD¼PS 563J
R40	Carbon film 56k	RD¼PS 563J
R41	Carbon film 470	RD¼PSF 471J
R42	Carbon film 470	RD¼PSF 471J
R43	Carbon film 220	RD¼PS 221J
R44	Carbon film 220	RD¼PS 221J
R45	Carbon film 100	RD¼PSF 101J
R46	Carbon film 100	RD¼PSF 101J
R47	Carbon film 100	RD¼PSF 101J
R48	Carbon film 100	RD¼PSF 101J
R49	Carbon film 18k	RD¼PS 183J
R50	Carbon film 18k	RD¼PS 183J
R51	Carbon film 18k	RD¼PS 183J
R52	Carbon film 18k	RD¼PS 183J
R53	Metal oxide 4.7k 2W	RS2P 472J
R54	Metal oxide 4.7k 2W	RS2P 472J
R55	Metal oxide 4.7k 2W	RS2P 472J
R56	Metal oxide 4.7k 2W	RS2P 472J
R57	Metal oxide 10 2W	RS2P 100J
R58	Metal oxide 10 2W	RS2P 100J
R59	Metal oxide 10 2W	RS2P 100J
R60	Metal oxide 10 2W	RS2P 100J
R61	Wire wound 0.5 5W	RT5B 0R5K
R62	Wire wound 0.5 5W	RT5B 0R5K
R63	Wire wound 0.5 5W	RT5B 0R5K
R64	Wire wound 0.5 5W	RT5B 0R5K
R65	Wire wound 0.5 5W	RT5B 0R5K
R66	Wire wound 0.5 5W	RT5B 0R5K
R67	Wire wound 0.5 5W	RT5B 0R5K
R68	Wire wound 0.5 5W	RT5B 0R5K
R69	Metal oxide 10 2W	RS2P 100J
R70	Metal oxide 10 2W	RS2P 100J
R71	Metal oxide 10 2W	RS2P 100J
R72	Metal oxide 10 2W	RS2P 100J
R73	Carbon film 22	RD¼PSF 220J
R74	Carbon film 22	RD¼PSF 220J
R75	Carbon film 22	RD¼PSF 220J
R76	Carbon film 22	RD¼PSF 220J
R77	Carbon film 22	RD¼PSF 220J
R78	Carbon film 22	RD¼PSF 220J
R79	Carbon film 22	RD¼PSF 220J
R80	Carbon film 22	RD¼PSF 220J
R81	Carbon film 220	RD¼PS 221J
R82	Carbon film 220	RD¼PS 221J
VR1	Semi-fixed 2.2k-B	ACP-054
VR2	Semi-fixed 2.2k-B	ACP-054
VR3	Semi-fixed 470-B	ACP-033
VR4	Semi-fixed 470-B	ACP-033

CAPACITORS

Symbol	Description	Part No.
C1	Electrolytic 0.68 25V	CSZA R68M 25
C2	Electrolytic 0.68 25V	CSZA R68M 25
C3	Ceramic 120p 50V	CCDSL 121K 50
C4	Ceramic 120p 50V	CCDSL 121K 50
C5	Electrolytic 10 16V	CEA 100P 16
C6	Electrolytic 10 16V	CEA 100P 16
C7	Ceramic 47p 50V	CCDSL 470K 50
C8	Ceramic 47p 50V	CCDSL 470K 50
C9	Ceramic 39p 50V	CCDSL 390K 50
C10	Ceramic 39p 50V	CCDSL 390K 50
C11	Ceramic 10p 500V	CCDSL 100K 500
C12	Ceramic 10p 500V	CCDSL 100K 500
C13	Mylar 0.039 50V	CQMA 393J 50
C14	Mylar 0.039 50V	CQMA 393J 50
C15	Ceramic 0.047 150V	ACG-009
C16	Ceramic 0.047 150V	ACG-009
C17	Ceramic 82p 500V	CCDSL 820K 500
C18	Ceramic 82p 500V	CCDSL 820K 500
C19	Ceramic 82p 500V	CCDSL 820K 500
C20	Ceramic 82p 500V	CCDSL 820K 500
C21	Ceramic 0.047 150V	ACG-009
C22	Ceramic 0.047 150V	ACG-009
C23	Mylar 0.039 50V	CQMA 393J 50
C24	Mylar 0.039 50V	CQMA 393J 50
C25	Electrolytic 470 6V	CEA 471P 6
C26	Electrolytic 470 6V	CEA 471P 6
C27	Electrolytic 470 6V	CEA 471P 6
C28	Electrolytic 470 6V	CEA 471P 6

OTHERS

Symbol	Description	Part No.
	Heat sink	ANH-237
	Transistor socket	AKH-002
	insulating wafer	AEC-078
	Spacer	ANG-108
	AF choke coil	T63-009
	Contact strip (4P)	AKM-022

12.12 PROTECTION CIRCUIT ASSEMBLY (AWM-090)

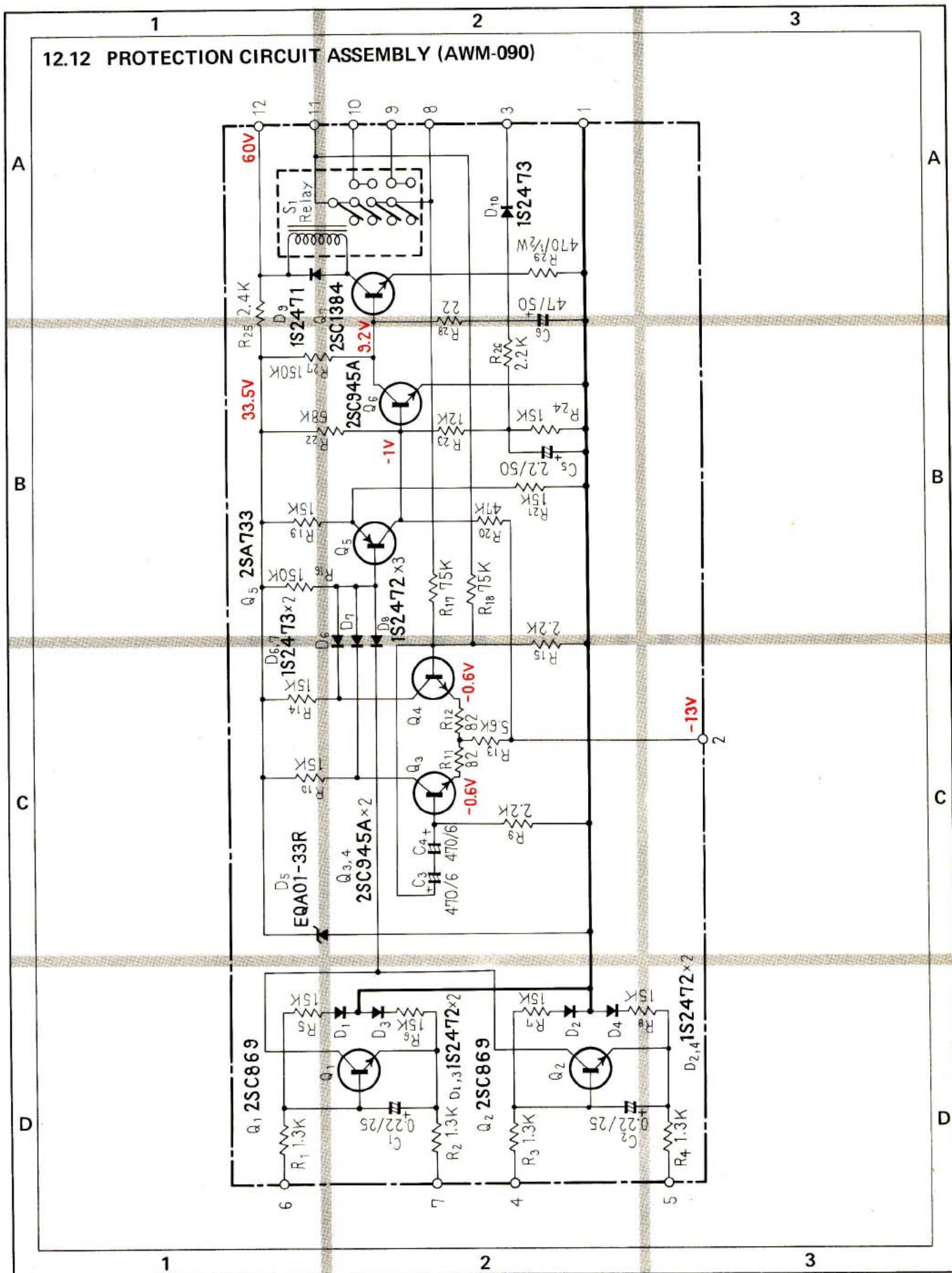

Parts List of Protection Circuit Assembly (AWM-090)

SEMICONDUCTORS

Symbol	Description	Part No.
Q1	Transistor	2SC869-C
Q2	Transistor	2SC869-C
Q3	Transistor	2SC945A-Q
Q4	Transistor	2SC945A-Q
Q5	Transistor	2SA733-Q
Q6	Transistor	2SC945-Q
Q7	Transistor	2SC1384-R
D1	Diode	1S2472
D2	Diode	1S2472
D3	Diode	1S2472
D4	Diode	1S2472
D5	Diode	EQA01-33R
D6	Diode	1S2473
D7	Diode	1S2473
D8	Diode	1S2472
D9	Diode	1S2471
D10	Diode	1S2473

CAPACITORS

Symbol	Description	Part No.
C1	Electrolytic 0.22 25V	CSSA R22 M25
C2	Electrolytic 0.22 25V	CSSA R22 M25
C3	Electrolytic 470 6V	CEA 471P 6
C4	Electrolytic 470 6V	CEA 471P 6
C5	Electrolytic 2.2 50V	CEA 2R2P 50
C6	Electrolytic 47 50V	CEA 470P 50

OTHER

Symbol	Description	Part No.
S1	Relay	ASR-020

RESISTORS

Symbol	Description	Part No.
R1	Carbon film 1.3k	RD $\frac{1}{4}$ PSF 132J
R2	Carbon film 1.3k	RD $\frac{1}{4}$ PSF 132J
R3	Carbon film 1.3k	RD $\frac{1}{4}$ PSF 132J
R4	Carbon film 1.3k	RD $\frac{1}{4}$ PSF 132J
R5	Carbon film 15k	RD $\frac{1}{4}$ PS 153J
R6	Carbon film 15k	RD $\frac{1}{4}$ PS 153J
R7	Carbon film 15k	RD $\frac{1}{4}$ PS 153J
R8	Carbon film 15k	RD $\frac{1}{4}$ PS 153J
R9	Carbon film 15k	RD $\frac{1}{4}$ PS 153J
R10	Carbon film 15k	RD $\frac{1}{4}$ PS 153J
R11	Carbon film 82	RD $\frac{1}{4}$ PS 820J
R12	Carbon film 82	RD $\frac{1}{4}$ PS 820J
R13	Carbon film 5.6k	RD $\frac{1}{4}$ PS 562J
R14	Carbon film 15k	RD $\frac{1}{4}$ PS 153J
R15	Carbon film 2.2k	RD $\frac{1}{4}$ PS 222J
R16	Carbon film 150k	RD $\frac{1}{4}$ PS 154J
R17	Carbon film 75k	RD $\frac{1}{4}$ PS 753J
R18	Carbon film 75k	RD $\frac{1}{4}$ PS 753J
R19	Carbon film 15k	RD $\frac{1}{4}$ PS 153J
R20	Carbon film 47k	RD $\frac{1}{4}$ PS 473J
R21	Carbon film 15k	RD $\frac{1}{4}$ PS 153J
R22	Carbon film 68k	RD $\frac{1}{4}$ PS 683J
R23	Carbon film 12k	RD $\frac{1}{4}$ PS 123J
R24	Carbon film 15k	RD $\frac{1}{4}$ PS 153J
R25	Carbon film 3.4k	RD $\frac{1}{4}$ PS 342J
R26	Carbon film 2.2k	RD $\frac{1}{4}$ PS 222J
R27	Carbon film 150k	RD $\frac{1}{4}$ PS 154J
R28	Carbon film 22	RD $\frac{1}{4}$ PS 220J
R29	Carbon film 470 $\frac{1}{2}$ W	RD $\frac{1}{2}$ PS 471J

12.13 SPEAKER SWITCH ASSEMBLY (AWS-095)

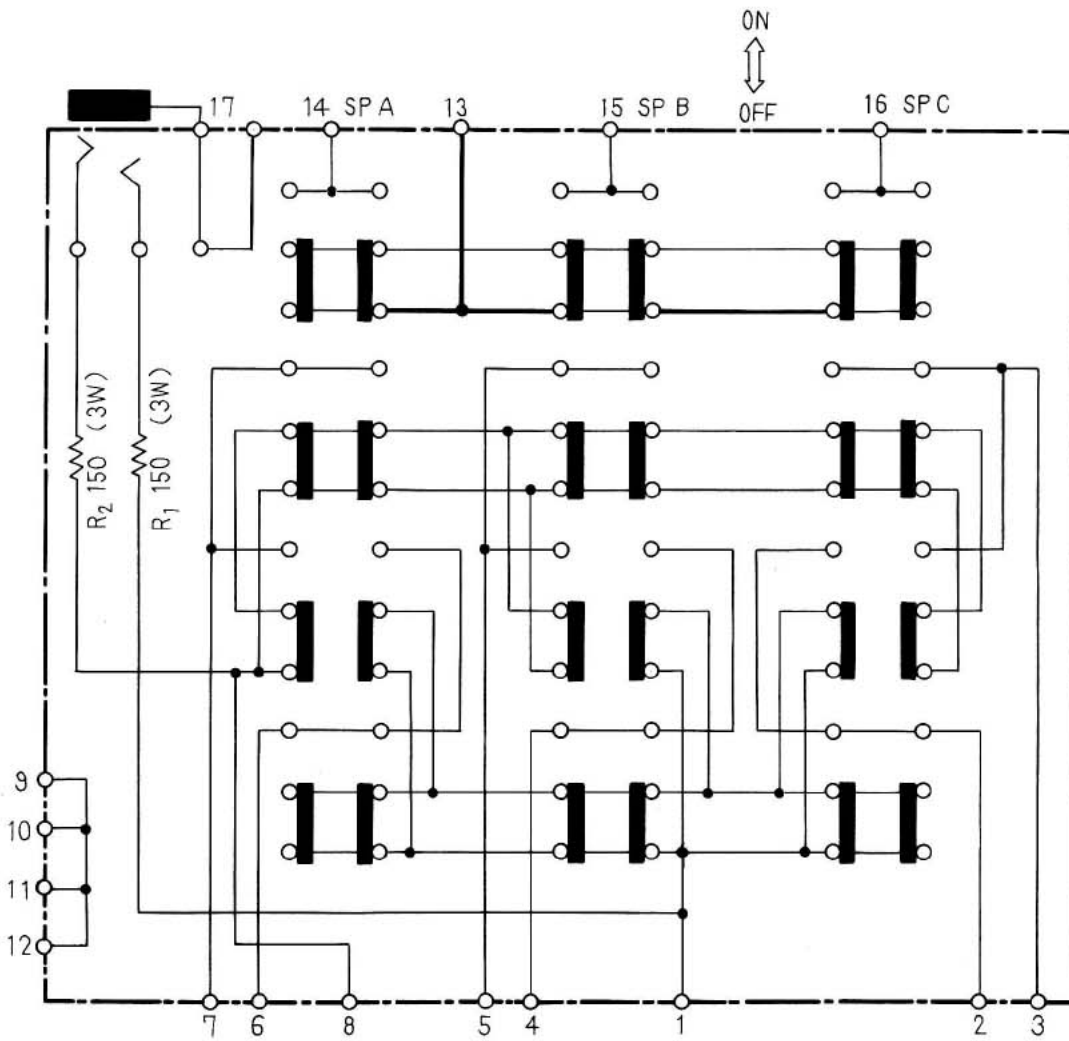

Parts List of Speaker Switch Assembly (AWS-095)

Symbol	Description	Part No.
S1	Push switch (SPEAKERS)	ASG-094
R1	Metal oxide resistor 150 3W	RS3P 151K
R2	Metal oxide resistor 150 3W	RS3P 151K
	PHONES jack	AKN-010

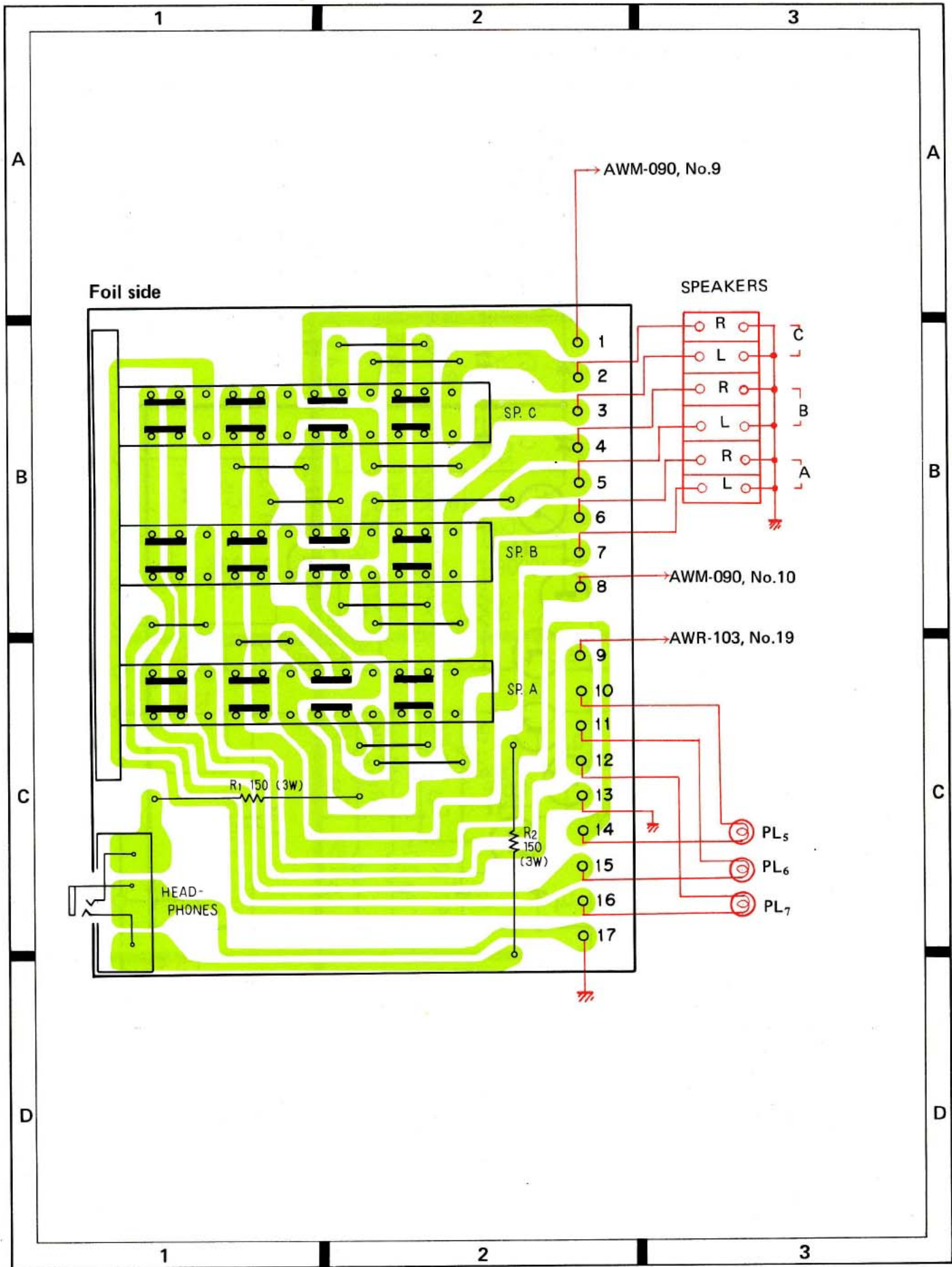

12.14 POWER SUPPLY CIRCUIT ASSEMBLY-A (AWR-103)

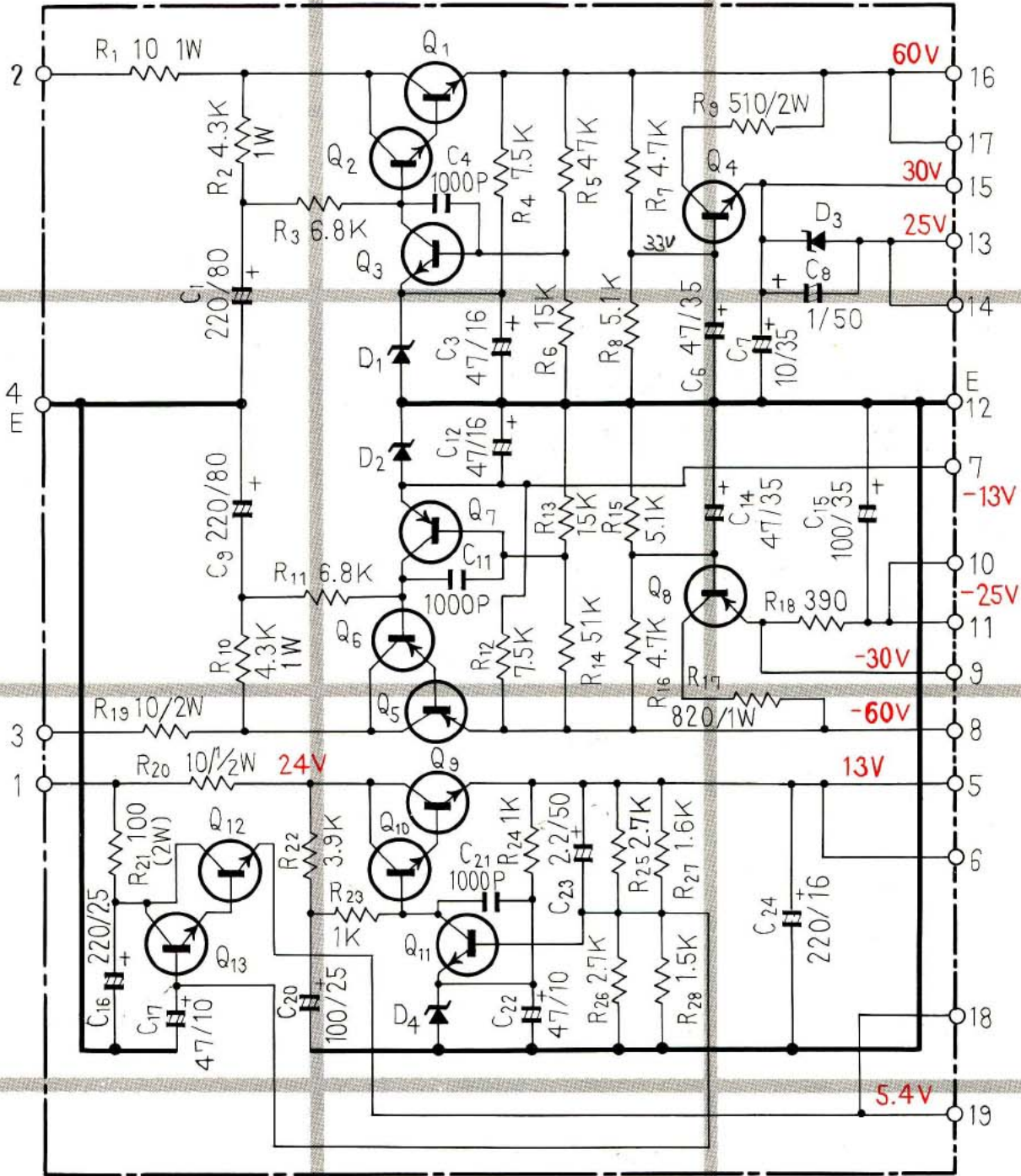

Transistors

- Q₁ : 2SD313P
- Q_{2,3} : 2SC869 × 2
- Q₄ : 2SC1318
- Q₅ : 2SB507P
- Q_{6,7} : 2SA628A × 2

- Q₈ : 2SA720
- Q_{9,12} : 2SD325R
- Q_{10,11,13} : 2SC945A × 3

Diodes

- D₁ : WZ-140
- D₂ : WZ-130
- D_{3,4} : WZ-061 × 2

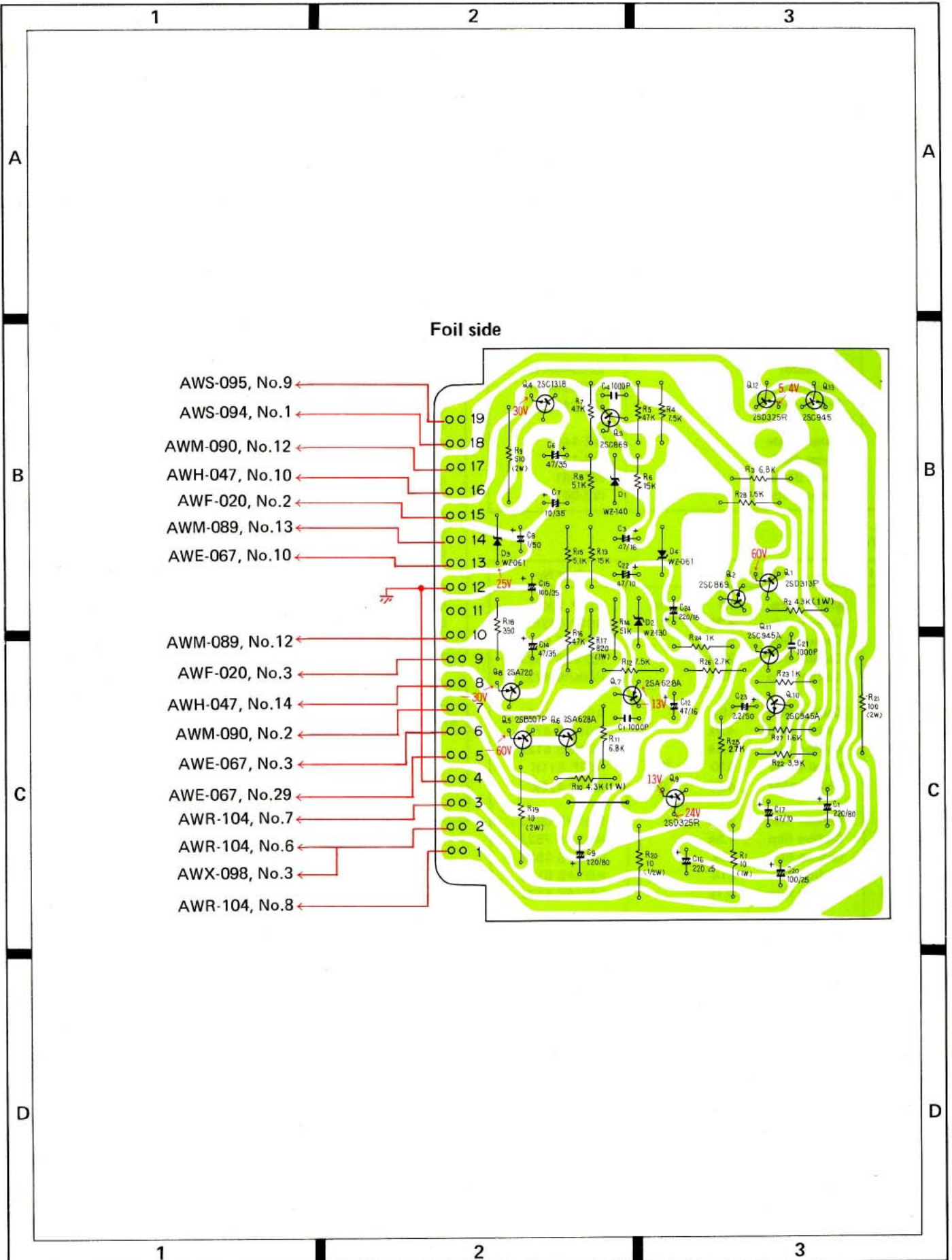

- Foil side**
- AWS-095, No.9 ←
 - AWS-094, No.1 ←
 - AWM-090, No.12 ←
 - AWH-047, No.10 ←
 - AWF-020, No.2 ←
 - AWM-089, No.13 ←
 - AWE-067, No.10 ←
 - AWM-089, No.12 ←
 - AWF-020, No.3 ←
 - AWH-047, No.14 ←
 - AWM-090, No.2 ←
 - AWE-067, No.3 ←
 - AWE-067, No.29 ←
 - AWR-104, No.7 ←
 - AWR-104, No.6 ←
 - AWX-098, No.3 ←
 - AWR-104, No.8 ←

Parts List of Power Supply Circuit Assembly-A (AWR-103)

SEMICONDUCTORS

Symbol	Description	Part No.
Q1	Transistor	2SD313P-E
Q2	Transistor	2SC869-D
Q3	Transistor	2SC869-D
Q4	Transistor	2SC1318-R
Q5	Transistor	2SB507P-E
Q6	Transistor	2SA628A-D
Q7	Transistor	2SA628A-D
Q8	Transistor	2SA720-R
Q9	Transistor	2SD325R-E
Q10	Transistor	2SC945A-R
Q11	Transistor	2SC945A-R
Q12	Transistor	2SD325R-E
Q13	Transistor	2SC945A-R
D1	Zener diode	WZ-140
D2	Zener diode	WZ-130
D3	Zener diode	WZ-061
D4	Zener diode	WZ-061

RESISTORS

Symbol	Description	Part No.
R1	Metal oxide 10 1W	RS1P 100K
R2	Metal oxide 4.3k 1W	RS1P 432K
R3	Carbon film 6.8k	RD½PS 682J
R4	Carbon film 7.5k	RD½PS 752J
R5	Carbon film 47k	RD½PS 473J
R6	Carbon film 15k	RD½PS 153J
R7	Carbon film 4.7k	RD½PS 472J
R8	Carbon film 5.1k	RD½PS 512J
R9	Metal oxide 510 2W	RS2P 511K
R10	Metal oxide 4.3k 1W	RS1P 432K
R11	Carbon film 6.8k	RD½PS 682J
R12	Carbon film 7.5k	RD½PS 752J
R13	Carbon film 15k	RD½PS 153J
R14	Carbon film 51k	RD½PS 513J
R15	Carbon film 5.1k	RD½PS 512J
R16	Carbon film 4.7k	RD½PS 472J
R17	Metal oxide 820 1W	RS1P 821K
R18	Carbon film 390	RD½PS 391J
R19	Metal oxide 10 2W	RS2P 100K
R20	Carbon film 10 ½W	RD½PS 100J
R21	Metal oxide 100 2W	RS2P 101K
R22	Carbon film 3.9k	RD½PS 392J
R23	Carbon film 1k	RD½PS 102J
R24	Carbon film 1k	RD½PS 102J
R25	Carbon film 2.7k	RD½PS 272J
R26	Carbon film 2.7k	RD½PS 272J
R27	Carbon film 1.6k	RD½PS 162J
R28	Carbon film 1.5k	RD½PS 152J

CAPACITORS

Symbol	Description	Part No.
C1	Electrolytic 220 80V	CEA 221P 80
C2
C3	Electrolytic 47 16V	CEA 470P 16
C4	Ceramic 1000p 50V	CKDYF 102Z 50
C5
C6	Electrolytic 47 35V	CEA 470P 35
C7	Electrolytic 10 35V	CEA 100P 35
C8	Electrolytic 1 50V	CEA 010P 50
C9	Electrolytic 220 80V	CEA 221P 80
C10
C11	Ceramic 1000p 50V	CKDYF 102Z 50
C12	Electrolytic 47 16V	CEA 470P 16
C13
C14	Electrolytic 47 35V	CEA 470P 35
C15	Electrolytic 100 35V	CEA 101P 35
C16	Electrolytic 220 25V	CEA 221P 25
C17	Electrolytic 47 10V	CEA 470P 10
C18
C19
C20	Electrolytic 100 25V	CEA 101P 25
C21	Ceramic 1000p 50V	CKDYF 102Z 50
C22	Electrolytic 47 10V	CEA 470P 10
C23	Electrolytic 2.2 50V	CEA 2R2P 50
C24	Electrolytic 220 16V	CEA 221P 16

OTHERS

Symbol	Description	Part No.
	Heat sink	ANH-117
	Heat sink	ANH-237
	Transistor socket	AKH-002
	Insulated wafer	AEC-043

12.15 SURGE CURRENT SUPPRESSOR ASSEMBLY (AWX-098)

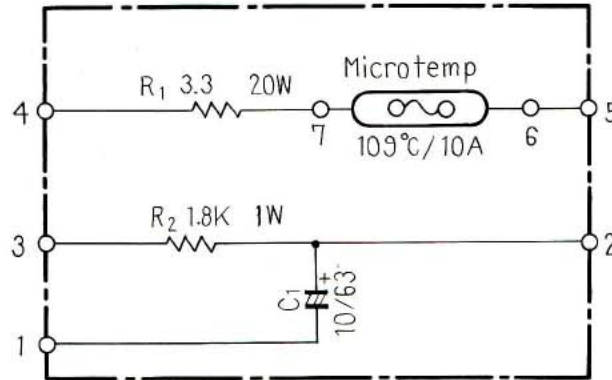

Foil side

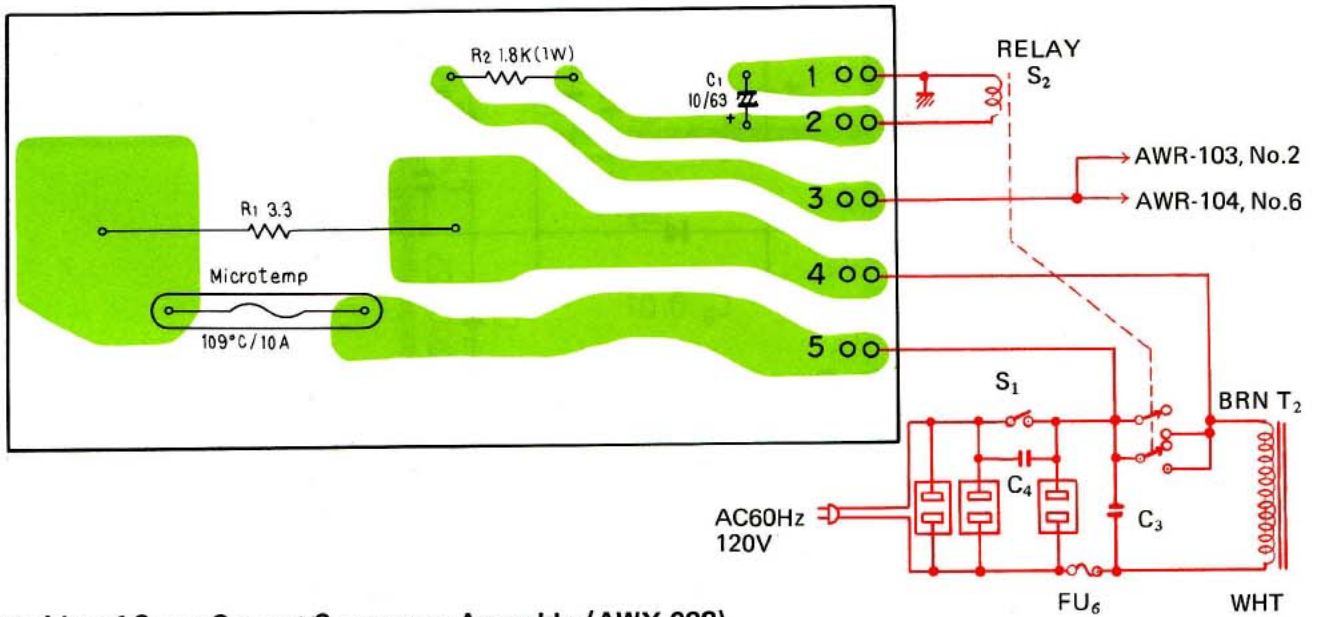

Parts List of Surge Current Suppressor Assembly (AWX-098)

RESISTORS

Symbol	Description	Part No.
R1	Wire wound 3.3Ω 20W	ACN-006
R2	Metal oxide 1.8k 1W	RS1PF 182J

OTHER

Symbol	Description	Part No.
	Micro-temp.	AEX-001

CAPACITOR

Symbol	Description	Part No.
C1	Electrolytic 10 63V	CEA 100P 63

12.16 POWER SUPPLY CIRCUIT ASSEMBLY-B (AWR-104)

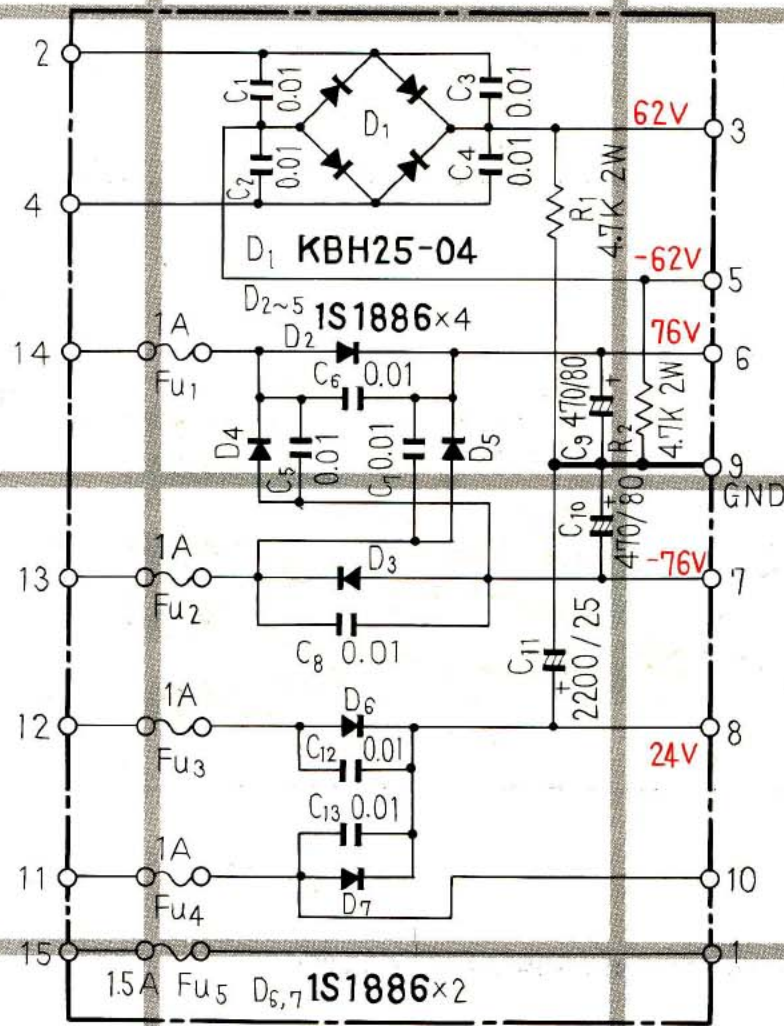

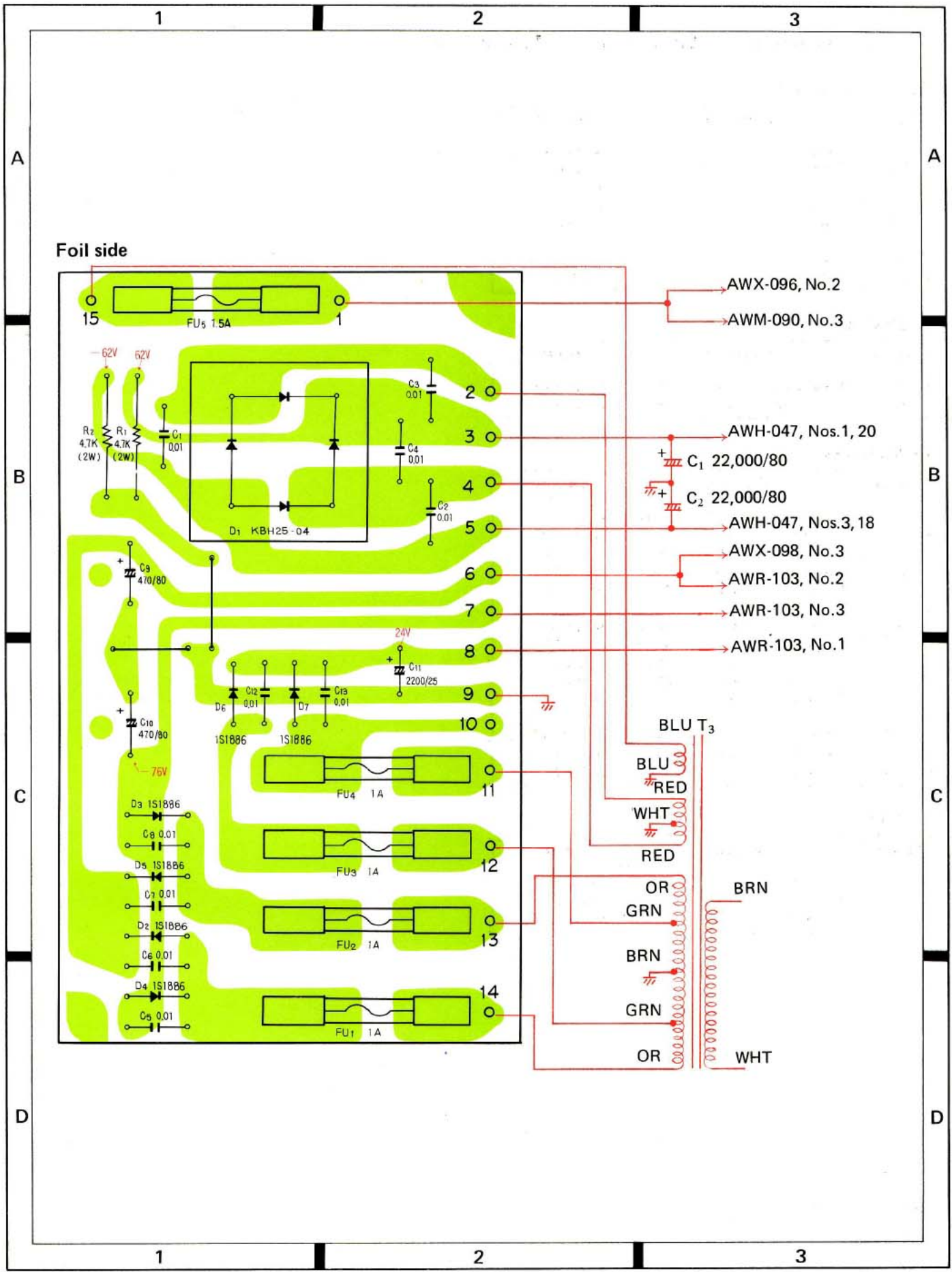

Parts List of Power Supply Circuit Assembly-B (AWR-104)

SEMICONDUCTORS

Symbol	Description	Part No.
D1	Diode	KBH25-04
D2	Diode	1S1886
D3	Diode	1S1886
D4	Diode	1S1886
D5	Diode	1S1886
D6	Diode	1S1885
D7	Diode	1S1885

RESISTORS

Symbol	Description	Part No.
R1	Metal oxide 4.7k 2W	RS 2P 472K
R2	Metal oxide 4.7k 2W	RS 2P 472K

CAPACITORS

Symbol	Description	Part No.
C1	Ceramic 0.01 150V	ACG-004
C2	Ceramic 0.01 150V	ACG-004
C3	Ceramic 0.01 150V	ACG-004
C4	Ceramic 0.01 150V	ACG-004
C5	Ceramic 0.01 150V	ACG-004
C6	Ceramic 0.01 150V	ACG-004
C7	Ceramic 0.01 150V	ACG-004
C8	Ceramic 0.01 150V	ACG-004
C9	Electrolytic 470 80V	ACH-038
C10	Electrolytic 470 80V	ACH-038
C11	Electrolytic 2200 25V	CEA 222P 25
C12	Ceramic 0.01 150V	ACG-004
C13	Ceramic 0.01 150V	ACG-004

OTHERS

Symbol	Description	Part No.
	Fuse clip	AKP-013
	Fuse clip	AKP-030
	Heat sink	ANH-297

13. PACKING

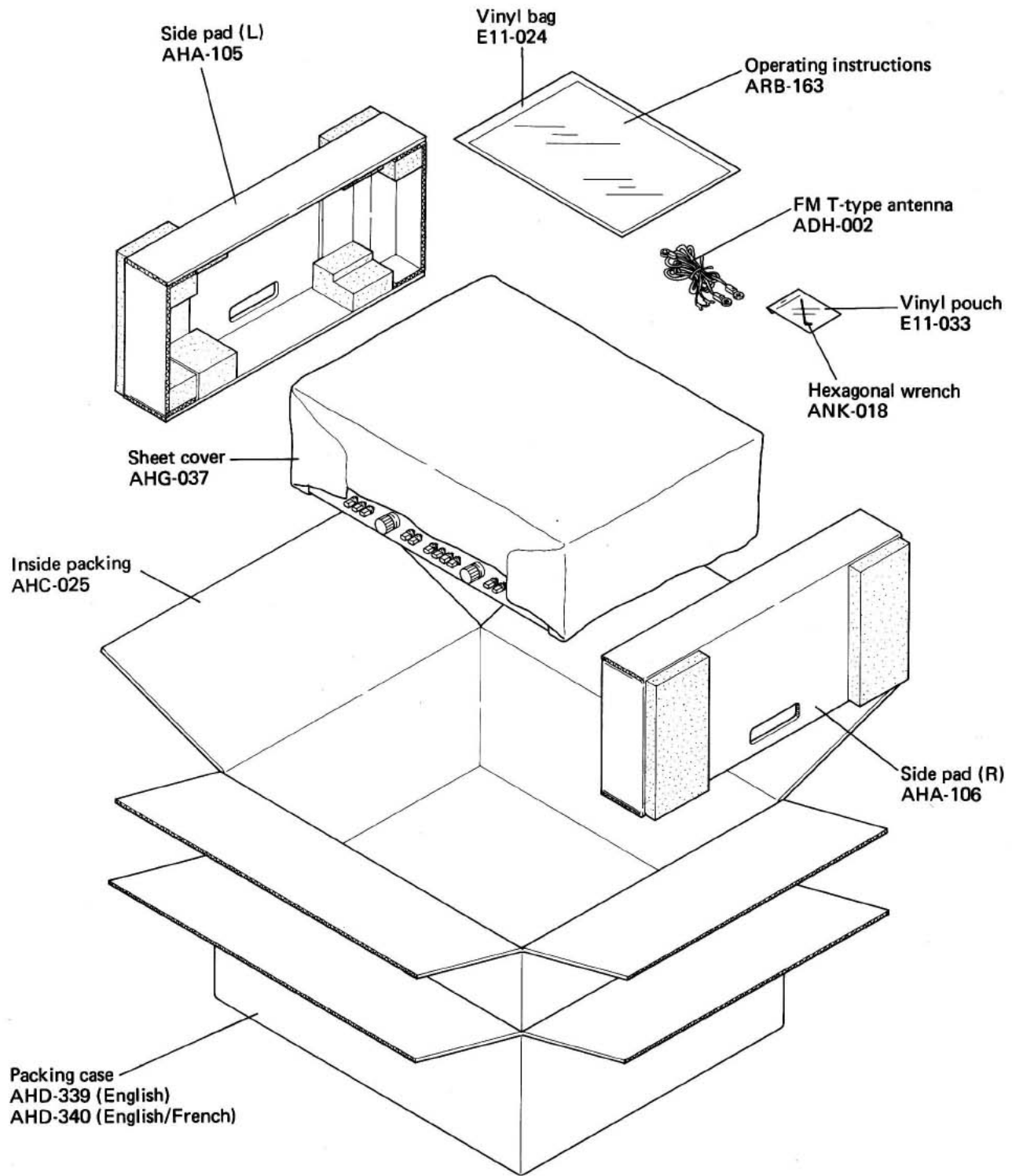

14. PARTS LIST OF EXPLODED VIEWS

Parts No.	Parts Name
AAA-034	Knob
AAB-100	Knob
AAB-104	Knob
AAD-113	Knob
AAD-114	Knob
AAF-051	Dial Pointer
AAG-105	Dial Panel
AAP-036	Blind Sash
AAT-025	Shaft Cover
AAT-026	Indicator
AAT-027	Indicator
AAT-028	Indicator
AAW-040	Double Meter
ABA-002	Screw (3 x 8)
ABA-012	Screw (4 x 8)
ABA-082	Screw (3 x 10)
ABA-113	Screw (4 x 15)
ABA-114	Pulley Shaft
ABA-116	Screw (3 x 6)
ABE-006	Washer
ABH-022	Coil Spring
ABN-021	Union Nut
ABN-022	Flange Boss
ABN-023	Flange Nut (M6)
ABN-024	Flange Nut (M9)
ACH-056	Electrolytic Capacitor (22,000 μ F 30V)
ACV-163	Variable Resistor (100k ohm HB)
ACV-165	Variable Resistor (102k ohm)
ACV-166	Variable Resistor (102.6k ohm)
ACV-167	Variable Resistor (99k ohm)
ACV-168	Variable Resistor (102k ohm)
ACV-169	Variable Resistor (50k ohm)
ADG-013	AC Power Cord
ADH-002	FM T-type Antenna
ADX-027	Connector Ass. (4P)
ADX-028	Connector Ass. (4P)
AEB-085	Rubber Holder (A)
AEB-086	Rubber Holder (B)
AEC-076	Insulated Wafer
AEC-079	Strain Relief
AEC-101	Pulley
AEC-258	Spacer
AEC-260	Acrylic Board
AED-018	Mask
AEK-104	Fuse (1.5A)
AEK-106	Fuse (1A)
AEK-302	Fuse (10A)
AEL-056	Lamp Ass.
AEL-069	Lamp (with Wire)

Parts No.	Parts Name
AEL-072	Lamp (with Wire)
AEL-073	Lamp (with Wire)
AEL-074	Lamp (with Wire)
AEL-075	Lamp (with Wire)
AEL-076	Lamp (with Wire)
AHA-105	Side Pad (L)
AHA-106	Side Pad (R)
AHC-025	Inside Packing
AHD-339	Packing Case (English)
AHD-340	Packing Case (English/French)
AHG-037	Sheet Cover
AKA-004	Terminal
AKB-019	Terminal
AKB-030	Terminal
AKB-033	Terminal
AKE-012	Terminal
AKE-014	Terminal
AKH-001	Transistor Socket
AKM-004	Jumper Plug
AKN-010	Phone Jack
AKN-013	Phone Jack
AKP-005	AC Socket
AKP-007	REC-PB Socket (5P)
AKR-028	Fuse Holder (KCU model)
AKR-031	Voltage Selector SW (S model)
AMM-050	Top Cover
ANB-388	Front Panel Ass.
ANK-018	Hexagonal Wrench
ARB-163	Operating Instruction (KCU model)
ARB-165	Operating Instruction (S model)
ASG-094	Push Switch
ASG-095	Push Switch
ASG-098	Push Switch
ASH-015	Slide Switch
ASK-080	Lever Switch
ASK-090	Lever Switch
ASK-092	Lever Switch
ASR-019	Relay
ATB-050	Ferrite Bar-Antenna
ATT-266	Power Transformer (KCU)
ATT-290	Power Transformer (S)
AWE-067	Tuner Ass.
AWF-020	Equalizer Amp. Ass.
AWG-040	Flat Amp. Ass.
AWG-041	Control Amp. Ass.
AWH-047	Power Amp. Ass.
AWM-089	Filter Amp. Ass.
AWM-090	Protection Ass.
AWR-103	Power Supply Ass. (A)
AWR-104	Power Supply Ass. (B)

Parts No.	Parts Name
AWS-094	Function Switch Ass.
AWS-095	Speaker Switch Ass.
AWX-062	5P Connector Ass.
AWX-096	Lamp Board Ass.
AWX-097	Mic Jack Ass.
AWX-098	Surge Killer Ass.
AWX-099	De-emphasis SW Ass. (KCU model)
AWX-101	De-emphasis SW Ass. (S model)
AXA-111	Tuning Shaft Ass.
AXA-113	Tuning Drum Ass.
B71-004	Nut (M9)
B71-010	Nut (M7)
E11-024	Vinyl Bag
E11-033	Vinyl Pouch
M45-086	Washer (M9)
W72-096	Bar-Antenna Holder
2SB539C	Transistor
2SD287C	Transistor

15. ADDITIONAL INFORMATION(SX-1050/S)

NOTE:

- For servicing of the SX-1050/S please refer to pages 1 ~ 101 of SX-1050/KCU manual with the exception of the power transformer section and de-emphasis switch assembly which are described in this supplement.

Miscellaneous Parts List

SEMICONDUCTORS

Symbol	Description	Part No.
Q23	Transistor	2SB539C-S
Q24	Transistor	2SB539C-S
Q25	Transistor	2SD287C-S
Q26	Transistor	2SD287C-S
Q27	Transistor	2SB539C-S
Q28	Transistor	2SB539C-S
Q29	Transistor	2SD287C-S
Q30	Transistor	2SD287C-S

SWITCHES

Symbol	Description	Part No.
S1	Lever switch (POWER)	ASK-080
S2	Relay	ASR-015
S5	Voltage selector switch	AKR-031

TRANSFORMERS AND COIL

Symbol	Description	Part No.
T1	Ferrite balun	T22-025
T2	Ferrite bar-antenna	ATB-050
T3	Power transformer	ATT-290

RESISTOR AND CAPACITORS

Symbol	Description	Part No.
R1	Carbon film 2.2M 1/4W	RD1/4PS 225J
C1	Electrolytic 22000 80V	ACH-056
C2	Electrolytic 22000 80V	ACH-056
C3	Ceramic 0.01 250V	ACG-001
C4	Ceramic 0.01 250V	ACG-001
C5	Ceramic 0.01 50V	CKDYF 103Z 50
C6	Ceramic 0.01 50V	CKDYF 103Z 50
C7	Ceramic 0.01 50V	CKDYF 103Z 50
C8	Ceramic 0.01 50V	CKDYF 103Z 50
C9	Ceramic 0.01 50V	CKDYF 103Z 50
C10	Ceramic 0.01 50V	CKDYF 103Z 50
C11	Ceramic 0.01 50V	CKDYF 103Z 50

NOTE:

- Capacitors: in μF unless otherwise noted p:pF
- Resistors: in Ω , 1/4W unless otherwise noted k:k Ω , M:M Ω

FUSES

Symbol	Description	Part No.
F1	Fuse 1A	AEK-106
F2	Fuse 1A	AEK-106
F3	Fuse 1A	AEK-106
F4	Fuse 1A	AEK-106
F5	Fuse 2A	AEK-103
F6	Fuse 5A (110V/120V) Fuse 10A (220V/240V)	AEK-108 AEK-302

LAMPS

Symbol	Description	Part No.
PL1	Lamp assembly 8V 300mA	AEL-056
PL2	Lamp assembly 8V 300mA	AEL-056
PL3	Lamp assembly 8V 300mA	AEL-056
PL4	Lamp assembly 8V 300mA	AEL-056
PL5	Lamp with wire 8V 50mA	AEL-074
PL6	Lamp with wire 8V 50mA	AEL-072
PL7	Lamp with wire 8V 50mA	AEL-073
PL8	Lamp with wire 8V 50mA	AEL-076
PL9	Lamp with wire 8V 50mA	AEL-075
PL10	Lamp with wire 8V 50mA	AEL-074
PL11	Lamp with wire 8V 50mA	AEL-072
PL12	Lamp with wire 8V 50mA	AEL-073
PL13	Lamp with wire 8V 50mA	AEL-069

OTHERS

Symbol	Description	Part No.
	Operating instructions	ARB-165
	Packing case	AHD-339

DE-EMPHASIS SWITCH ASSEMBLY (AWX-101)

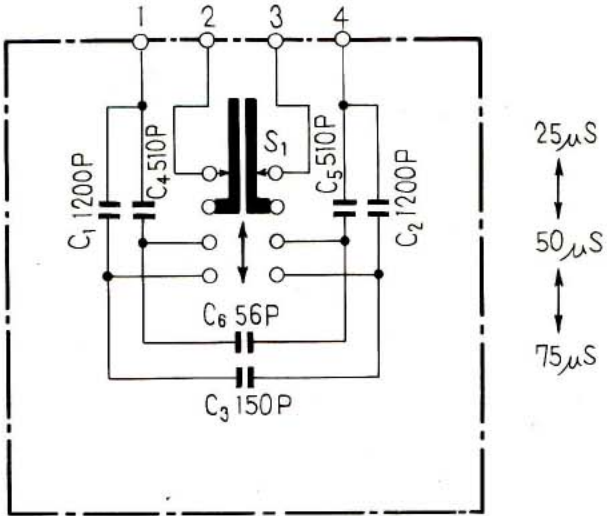

Foil side

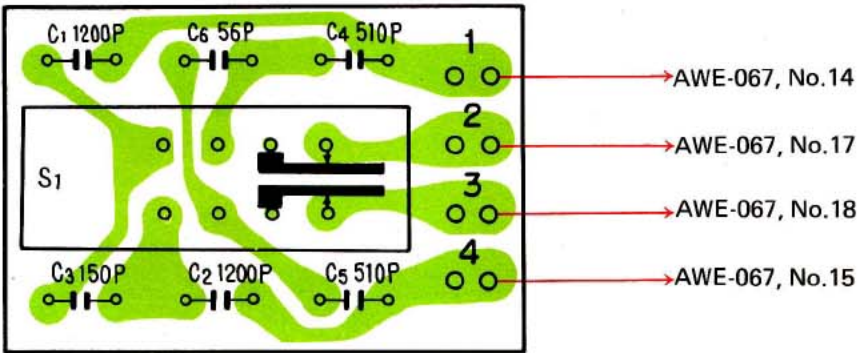

Parts List of De-emphasis Switch Assembly (AWX-101)

CAPACITORS

Symbol	Description	Part No.
C1	Ceramic 1200p 50V	CKDYA 122J 50
C2	Ceramic 1200p 50V	CKDYA 122J 50
C3	Ceramic 150p 50V	CCDSL 151K 50
C4	Styrol 510p 50V	CQSA 511J 50
C5	Styrol 510p 50V	CQSA 511J 50
C6	Ceramic 56p 50V	CCDSL 560K 50

SWITCH

Symbol	Description	Part No.
S1	Slide switch	ASH-017

PIONEER ELECTRONIC CORPORATION

4-1, Meguro 1-Chome, Meguro-ku, Tokyo 153, Japan

U.S. PIONEER ELECTRONICS CORPORATION

75 Oxford Drive, Moonachie, New Jersey 07074, U.S.A.

PIONEER ELECTRONIC (EUROPE) N.V.

Luithagensteenweg no. 9, 2030 Antwerp, Belgium

PIONEER ELECTRONICS AUSTRALIA PTY. LTD.

178-184 Boundary Road, Braeside, Victoria 3195, Australia

© DEC. 1975

Printed in Japan

Schematic Diagram

A

A

B

B

C

C

D

D

