

AM/FM STEREO RECEIVER

SX-1050

OPERATING INSTRUCTIONS

KCU

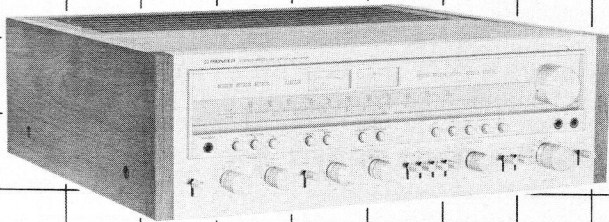

Walnut veneered top and side panels are used in the construction of this cabinet.

WARNING: TO PREVENT FIRE OR SHOCK HAZARD,
DO NOT EXPOSE THIS APPLIANCE TO RAIN OR
MOISTURE.

 **PIONEER**[®]

CONTENTS

Stereo System Composition	2	Playing Records	14
SX-1050 Features	3	Using the AUX Jacks	14
Connection Diagram	4	Microphones	14
Connections	6	Effective Operation	15
Antenna and Ground Connections	8	Tape Deck Operations	16
Front Panel Facilities	10	Adaptor Jacks for Increased Versatility	17
Prior to Switching Power On	13	Employing PRE OUT and POWER IN Jacks ..	19
FM Reception	13	Specifications	20
AM Reception	13	Conditions Frequently Mistaken For Malfunction	22

STEREO SYSTEM COMPOSITION

Tape Deck

- Be sure to install reel clamps when using vertically.
- Always keep heads clean.
- Do not neglect recorded tape for long periods.
- Avoid magnetic fields.

Turntable

- Protect from vibrations and close dust cover whenever possible.
- Store records vertically and protect from dust and dirt.

Speaker Systems

Rear and side panels of left and right speakers should have the same surroundings. (Placing with rear panel against a wall improves bass)

Install speakers so that vibrations are not transferred directly to the floor. (Employ stands or concrete blocks with bookshelf type speakers).

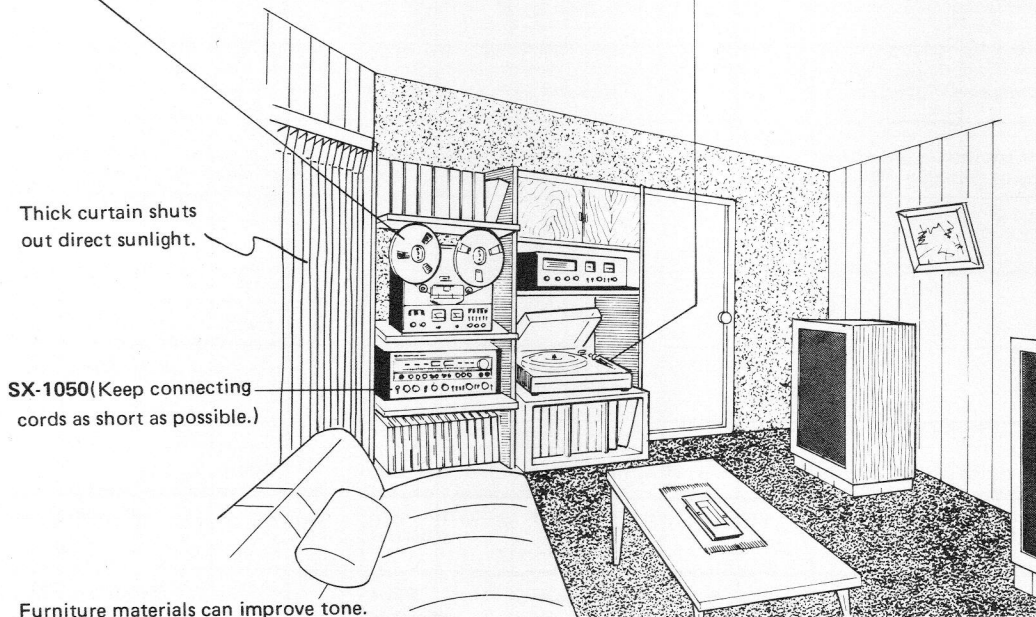

Carpet

Absorbs sound and vibrations
(Placing in front of speakers is also effective.)

Listening position slightly to the rear of the apex of an equilateral triangle formed with left and right speakers.

- Do not place equipment in locations that are unlevel or subject to vibration.
- Allow for good rear panel ventilation of components; avoid humidity and dust.
- Keep equipment away from radiators or other heat sources.

SX-1050 FEATURES

Full Performance FM Tuner Section

Equaling or surpassing many of the most respected separate component type tuners, the FM stereo tuner section has been designed to deliver the top level performance demanded by a music system utilizing this receiver. The front end includes a high precision 4-gang variable capacitor and two dual gate MOS FET devices for outstanding sensitivity, while minimizing intermodulation distortion and all classes of interference. This is followed by an IF circuit employing a 3-stage IC IF amplifier and ratio detector. Signal to noise ratio becomes enhanced to an astonishing 78dB during FM mono reception. Stable operation in the multiplex circuit is assured by the phase locked loop (PLL) IC construction plus an output stage that features excellent separation and distortion characteristics. A sharp response low pass filter eliminates unnecessary carrier components to produce clear left and right channel signals.

Anti Birdy Filter Suppresses Beat Interference

Insertion of an anti birdy filter circuit between the detector output and MPX stages prevents beat interference from a signal separated by 200kHz from the desired station. This avoids various types of detrimental phenomena since the interfering signal does not enter the MPX stage.

Perform Multipath Adjustments by Ear

Optimum antenna orientation for minimized multipath reflections can be easily determined by the newly designed built-in FM multipath circuit. By simply pressing a front panel switch, the proper antenna position can be adjusted by ear without the need for an oscilloscope or other test equipment.

Heavy Duty Power Supply

Massive toroidal core power transformer and two 22,000 microfarad electrolytic capacitors have been selected for stable operation at large power outputs. In comparison to conventional core transformers, the toroidal core design features low temperature rise, low leakage flux and excellent voltage conversion efficiency. High sound quality is thus assured down to the lowest frequencies.

Generous Margin Power Amplifier

First and second stage differential amplifiers, second stage using a current mirror circuit, parallel push pull final stage, and all stages direct coupled pure complementary OCL power amplifier provides plenty of low distortion power for every musical taste. SX-1050 delivers

Continuous power output of 120 watts* per channel minimum RMS at 8 ohms from 20 Hertz to 20,000 Hertz with no more than 0.1% total harmonic distortion.

Extremely Close RIAA Tolerance

The carefully engineered design holds RIAA deviation to within ± 0.2 dB. Balanced positive and negative power supply (± 30 V), PNP differential amplifier 1st stage, single ended push-pull (SEPP) last stage, and direct coupling of all stages are combined for low distortion, low output impedance and wide dynamic range. Stringently selected RIAA-circuit elements, including 1% tolerance metal-film low noise resistors and 2% tolerance styrol capacitors, raise the maximum nominal input to 300mV (at 1kHz, 0.1% THD) and provide magnificent record reproduction.

Twin Tone Controls for Broad Range of Adjustments

Main bass (100Hz) and treble (10kHz) controls each provide ± 10 dB variation in 2dB steps, while each of the sub (50Hz and 20kHz) tone controls provides ± 5 dB variation in 2.5dB steps. The main controls correspond to conventional tone controls and can be used in the same manner. If regulation of only the extreme high and low ends of the audio band is required, the sub controls can also be used independently. A truly vast range of tone adjustments becomes possible by employing both sets of controls in combination. Regardless of the control settings, a tone on-off switch allows a flat frequency response to be obtained instantly.

Decibel Calibrated Attenuator Type Volume Control

The main volume control is actually a precision 32 step attenuator. It is graduated in dB for direct readout and boasts a ganging error of within 0.5dB over the entire range from 0dB to -70dB. Operation is made easier by inserting an SEPP buffer amplifier between the volume and balance controls. Convenience is further enhanced by the inclusion of a coarse attenuator switch with 0 and -20dB positions. This allows instant volume reduction while changing records, tapes or other operations, without the need for continually readjusting the main control.

High Reliability Protection Circuit

Considerable surge current (reaching as high as 130 to 150 A) can be incurred due to the low internal resistance of the power transformer and large rating electrolytic capacitors. The built-in surge killer circuit, with a power relay inserted at the transformer primary side, suppresses this current to about 60 A and prevents damage to other equipment. In the event of malfunction, valuable semi-conductors and speakers are protected by a relay electronic protection circuit that detects DC output voltage or impedance overload. This circuit also functions to reduce noise during ON-OFF operation of the power supply.

**Measured pursuant to Federal Trade Commission's Trade Regulation rule on Power Output Claims for Amplifiers.*

CONNECTION DIAGRAM

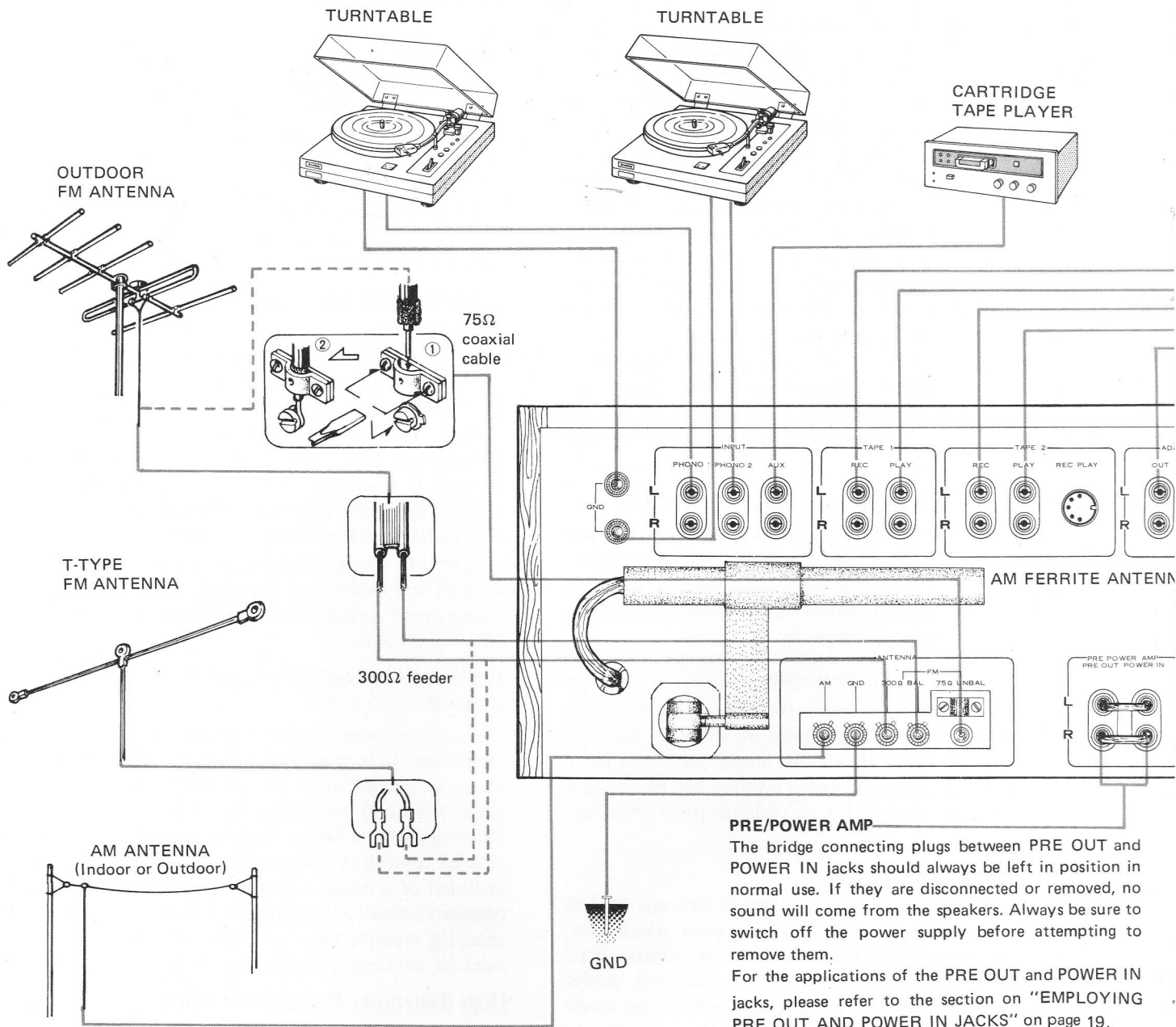

PRE/POWER AMP
 The bridge connecting plugs between PRE OUT and POWER IN jacks should always be left in position in normal use. If they are disconnected or removed, no sound will come from the speakers. Always be sure to switch off the power supply before attempting to remove them.
 For the applications of the PRE OUT and POWER IN jacks, please refer to the section on "EMPLOYING PRE OUT AND POWER IN JACKS" on page 19.

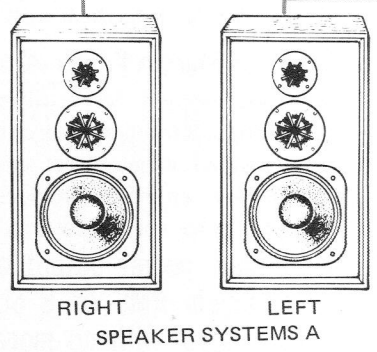

TAPE DECK
(open-reel, cassette)

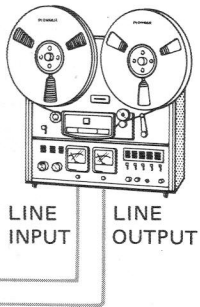

TAPE DECK
(Open-reel, cassette)

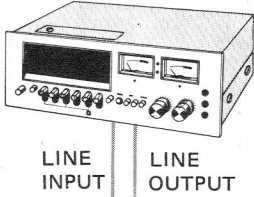

DOLBY NR ADAPTOR

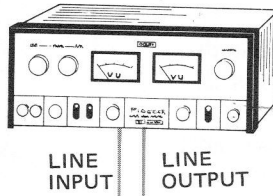

4 CHANNEL DISCRETE
FM ADAPTOR

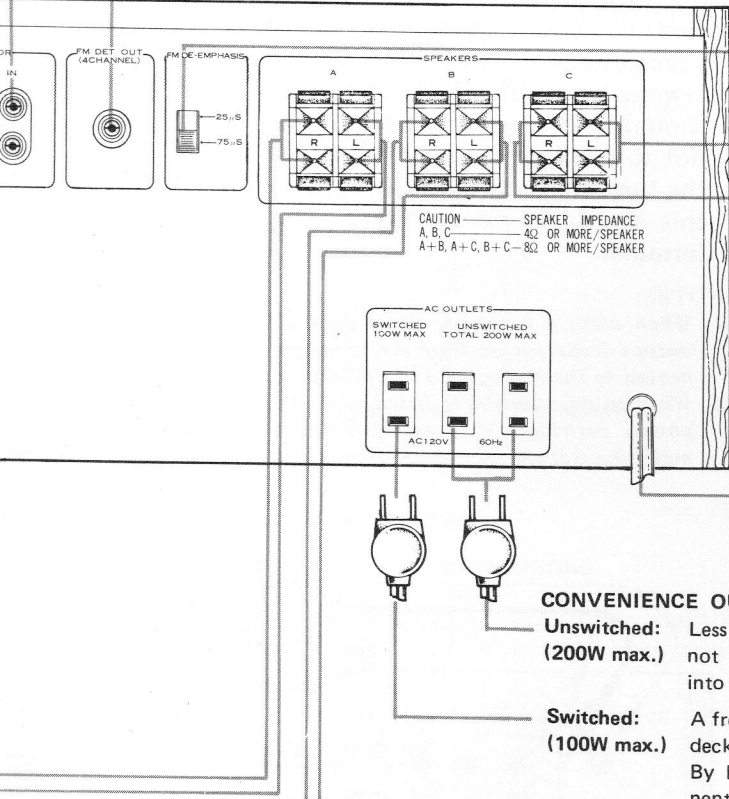
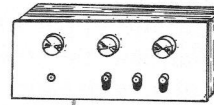

FM DE-EMPHASIS SWITCH

Normally, set this switch to "75µs". Be sure to set it to "25µs" only when listening to an FM broadcast (pre-emphasis; 25µsec.) with a Dolby* system NR adaptor connected between the ADAPTOR OUT and ADAPTOR IN terminals.

CAUTION — SPEAKER IMPEDANCE
A, B, C — 4Ω OR MORE / SPEAKER
A+B, A+C, B+C — 8Ω OR MORE / SPEAKER

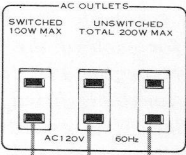

CONVENIENCE OUTLETS

Unswitched: Less frequently used components, which do not require coupled power, can be plugged into either of these outlets. (200W max.)

Switched: A frequently used component (turntable, tape deck, etc.) can be plugged into this outlet. By leaving the power switch of that component in the ON position, power supply to the component will be coupled with the SX-1050 switch operation. (100W max.)

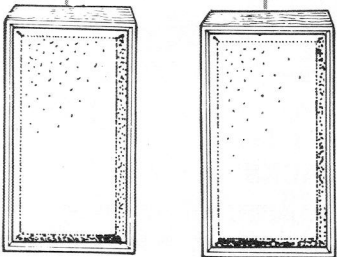

RIGHT LEFT
SPEAKER SYSTEMS B

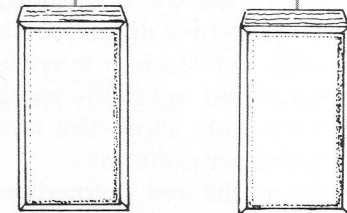

RIGHT LEFT
SPEAKER SYSTEMS C

* The word "Dolby" is a trademark of Dolby Laboratories Inc.

CONNECTIONS

SPEAKER SYSTEM CONNECTION

The receiver is equipped with three sets of speaker terminals (A, B, and C). Use the A terminals for the speakers in normal use.

As shown in Fig. 1, the upper socket (red) is the positive (+) terminal, and the lower (black) is the negative (-) terminal in each case.

In the same way, the speakers have positive and negative polarity (+ and - terminals). Be sure to connect terminals of the same polarity together (+ to +, and - to -).

NOTE:

When two sets of speaker systems are being used at the same time (A + B, A + C, or B + C), please ensure that the impedance of each speaker system is not less than 8Ω. If speaker systems with impedances below 8Ω are used, the receiver's protection circuit may operate to prevent sound being produced.

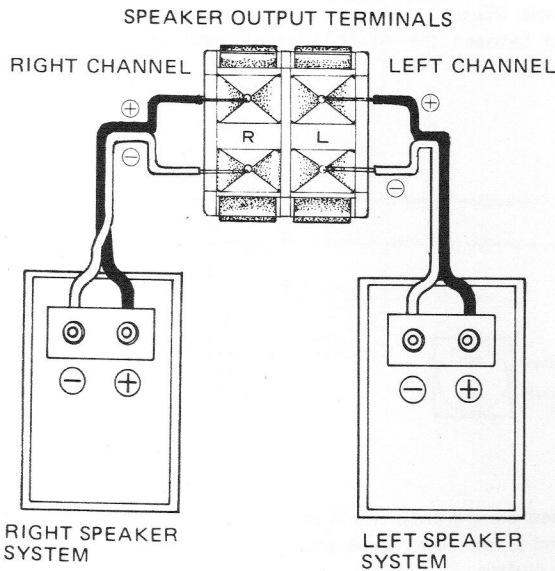

Fig. 1

Speaker Lead Wire Preparation & Connection(Fig. 2)

1. Strip about 10mm (3/8 inch) of the insulation from the end of the speaker lead wire.
2. If the conductor is stranded, twist the strands together so they do not come loose.
3. Depress the black colored lever of the speaker terminal and insert the speaker minus lead wire into the hole above the lever. Return the lever to its former position.
4. Push up the red colored lever of the speaker terminal and insert the speaker plus lead wire into the hole below the lever. Return the lever to its former position.

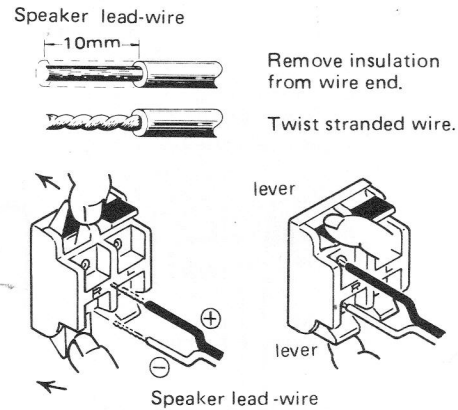

Fig. 2

TURNTABLE CONNECTIONS

The receiver is fitted with two sets of input jacks, PHONO 1 and PHONO 2, enabling two turntables fitted with magnetic phono cartridges to be connected.

- Connections between the turntable OUTPUT terminals and the receiver PHONO input jacks should be made as shown in Fig. 3, taking care not to confuse L & R channels. If, as in Fig. 3, the turntable is fitted with a ground lead or plug, this should be connected to the receiver GND terminal.

NOTES:

1. When using a turntable fitted with two tonearms, the output leads for each of the tonearms should be connected to the respective PHONO input jacks (1 and 2).
2. When using a turntable fitted with a moving coil (MC) phono cartridge, it is essential to use a special MC matching transformer or head amplifier.

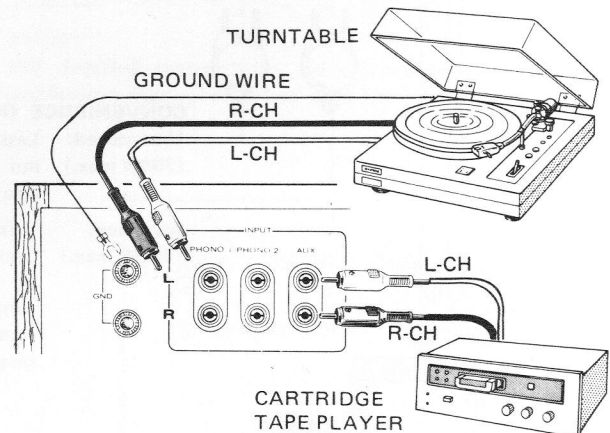

Fig. 3

USE OF THE AUX INPUT JACKS

These are a set of spare input jacks, which can be connected to a cartridge tape player, television sound tuner, or other signal source. The upper of the two jacks is the L (left) channel, and the lower is the R (right) channel (Fig. 3).

TAPE DECK CONNECTIONS

Two sets of recording output jacks (TAPE 1, 2 REC) and two sets of playback input jacks (TAPE 1, 2 PLAY) are provided, plus a DIN-type recording/playback connector (TAPE 2 REC/PLAY).

This means that in addition to normal recording and playback, two decks can be used to record at the same time, or to "dub" or duplicate recordings from one tape deck to the other.

Use the connecting cord(s) provided with the tape deck(s) to make the connections (see Fig. 4).

A tape deck can also be connected to the ADAPTOR jacks.

Connections for Recording

- The receiver output TAPE 1 REC jacks are connected to the recording input jacks (LINE INPUT) of the tape deck as shown in Fig. 4.

The upper jack of each pair is the L (left) channel and the lower is the R (right) channel.

When the tape deck is provided with a DIN-type connector for recording and playback, use an optional recording/playback cord to make the connection to the TAPE 2 REC/PLAY DIN connector (Fig. 5).

NOTE:

As the recording/playback cord connects both recording and playback functions at the same time, there is no need to make separate connections to either TAPE 2 REC output jacks or TAPE 2 PLAY input jacks. If the ADAPTOR OUT jacks are to be used, connect them to the tape deck input (LINE INPUT) jacks.

- When using two tape decks, the second tape deck should be connected to the receiver TAPE 2 REC output jacks. If, however, the first deck has been connected to the DIN-type recording/playback connector, the second deck should be connected to the TAPE 1 REC output jacks.

Connections for Playback

- Connect the receiver TAPE 1 PLAY input jacks to the playback output jacks (LINE OUTPUT or TAPE MONITOR) on the tape deck. The upper jack of each pair is the L (left) channel, and the lower is the R (right) channel.

NOTE:

If the ADAPTOR IN jacks are to be used, connect them to the tape deck output (LINE OUTPUT) jacks.

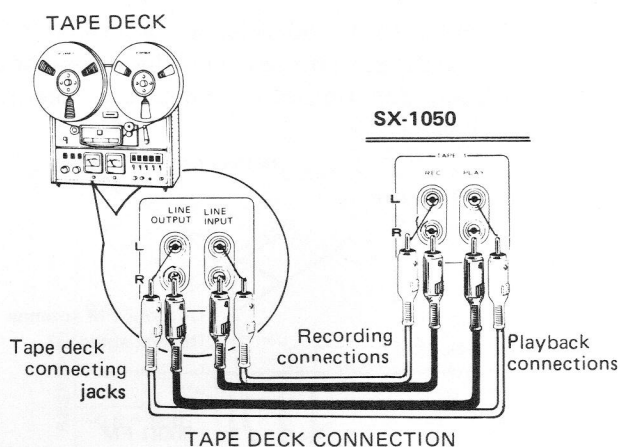

Fig. 4

- When using two tape decks, the second tape deck should be connected to the receiver TAPE 2 PLAY input jacks. If, however, the first deck has been connected to the DIN-type recording/playback connector (TAPE 2 REC/PLAY), the second deck should be connected to the TAPE 1 PLAY input jacks.

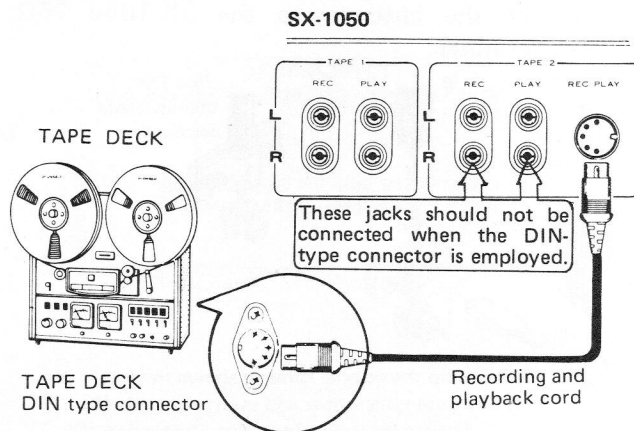

Fig. 5

ANTENNA AND GROUND CONNECTIONS

FM ANTENNA CONNECTIONS

For the best results you should use an outdoor-type FM antenna, although the simple T-type antenna supplied with the receiver may be used satisfactorily in areas of high signal strength (for instance, those very near to the FM station, or in a house of all-wooden construction).

FM Outdoor Antenna

Normally, install antenna as follows.

- Connect antenna feeder wire to the 300Ω antenna terminals of the SX-1050 as shown in Fig. 6.
- While listening to broadcasts, as described on page 13, install the antenna and determine the best location for optimum reception. Secure antenna firmly.

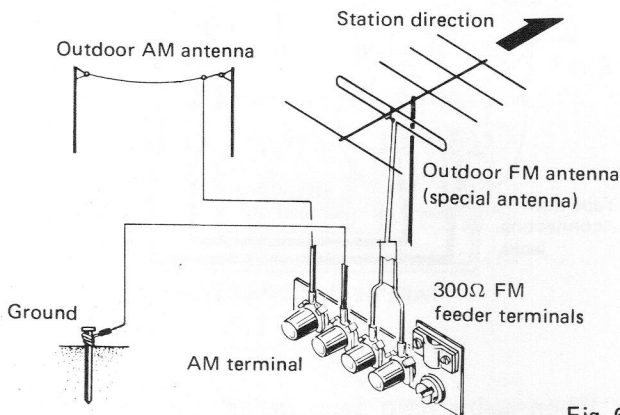
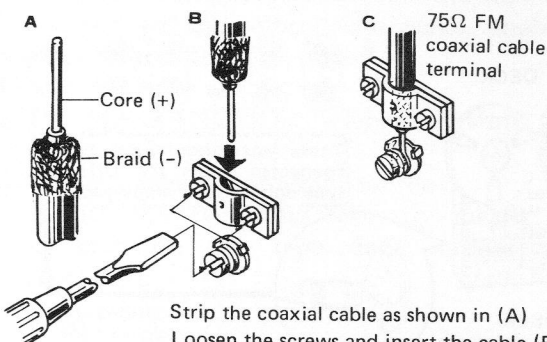

Fig. 6

Connection with Coaxial Cable

Urban areas with heavy traffic, industrial zones, or locations near high voltage power lines may experience interference even with a special FM antenna. In such cases seek the advice of an audio dealer. It may be advisable to employ 75Ω coaxial cable to connect the antenna to the SX-1050 75Ω UNBAL terminal.



Strip the coaxial cable as shown in (A)
Loosen the screws and insert the cable (B)
Tighten all screws for a firm connection (C)

Fig. 7

T-type Antenna

When stations are nearby, and in wooden frame buildings, etc. where FM signals are strong, the accessory T-type antenna can be employed.

- As shown in Fig. 8, connect the T-type antenna to the 300Ω antenna terminals. Spread the 2 arms of the antenna horizontally and while listening to an FM station, position them for best reception. The antenna can then be taped to a wall or ceiling.

NOTE:

Consult audio dealer for detailed information on FM antennas and coaxial cable installations.

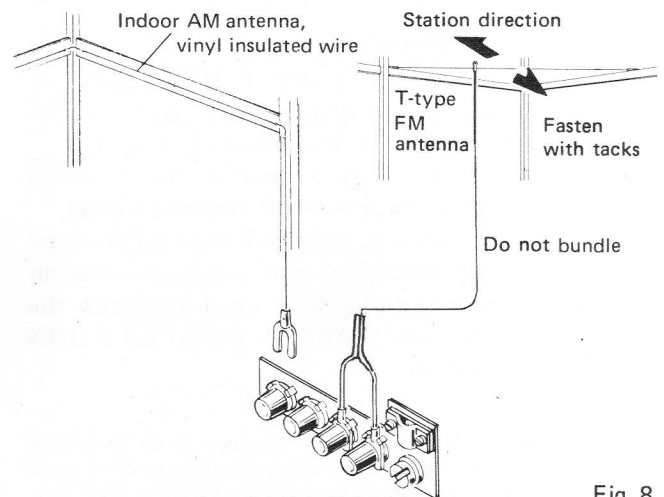

Fig. 8

FM Antenna Location

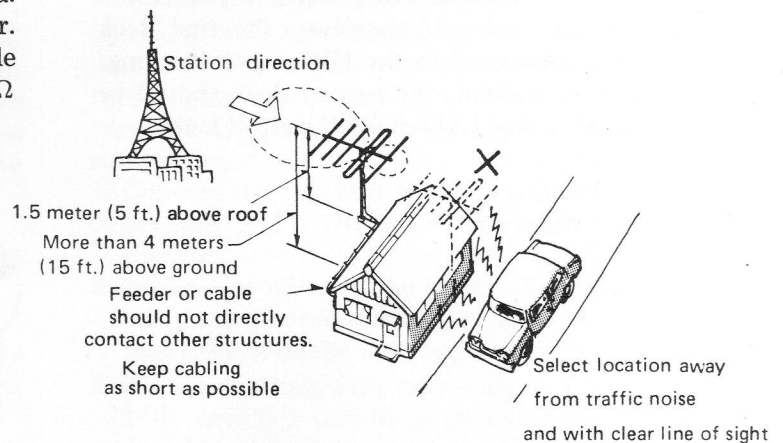

Fig. 9

AM BROADCAST ANTENNA

Normally, position the ferrite bar antenna (Fig. 10) for best reception while listening to an AM station as described on page 13.

AM Indoor Antenna

If reception is difficult with the bar antenna, an indoor AM antenna can be erected with vinyl insulated wire as shown in Fig. 8.

AM Outdoor Antenna

For optimum AM reception, an outdoor AM antenna using vinyl insulated wire can be erected as shown in Fig. 6.

GROUNDING

For maximum safety and noise reduction, connect the GND terminal to an earth ground (Fig. 6).

AM ferrite bar antenna

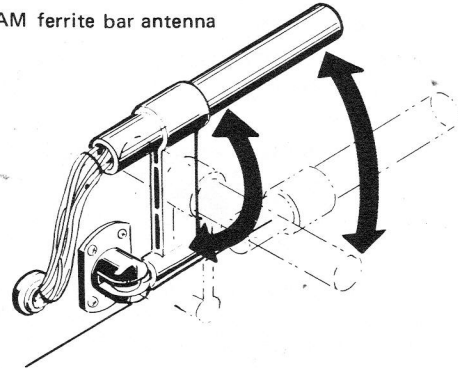

Fig. 10

FM MULTIPATH REFLECTION

This phenomenon is mainly caused as shown in Fig. 11, when the direct signals from an FM station are reflected by objects such as mountains and buildings. Both direct and reflected signals then enter the receiving antenna from different directions, and the slight timing difference due to the different paths results in mutual interference between the signals. Phase distortion, and reduced Signal to Noise ratio and channel separation affect the received sound.

Minimizing these effects calls for a sharply directional antenna, plus careful selection of the installation site and orientation.

Orientation

To minimize multipath reflections, adjust the antenna as follows:

1. Tune in the FM broadcast according to FM RECEPTION on page 13.
2. Depressing the FM MULTIPATH button will produce multipath noise through the speaker systems or headphones. (No music will be obtained.)
3. Turn the antenna, and find the direction which gives least noise.
4. Secure the antenna in this position for optimum reception of the FM broadcast.
5. Release the FM MULTIPATH button for normal operation of the receiver.

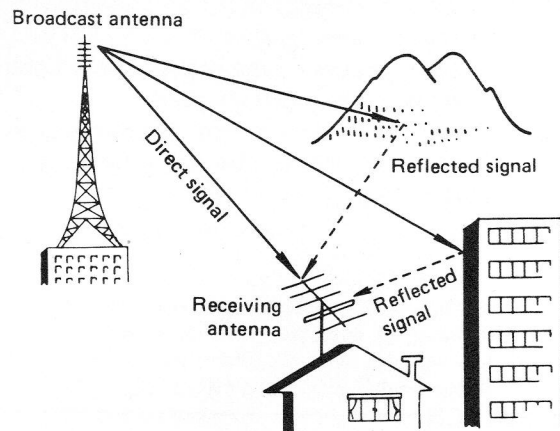

Fig. 11

FRONT PANEL FACILITIES

SPEAKER BUTTONS

Three sets of speaker terminals, A, B, and C, are provided on the rear panel, and the required speaker systems can be selected by depressing the **SPEAKERS** buttons as follows:

- A Speaker systems A operate
- B Speaker systems B operate
- C Speaker systems C operate

NOTES:

1. When any two buttons (A+B, B+C, C+A) are depressed simultaneously, the corresponding pairs of speaker systems will come into operation. However, it is not possible to operate all three speaker systems at the same time, even though all the buttons are depressed.
2. For private listening through headphones, return all the **SPEAKERS** buttons to the **OFF** (undepressed) position.

PHONES OUTPUT JACK

Accepts stereo headphones.

POWER SWITCH

After turning this switch **ON** there is a delay of some 3 to 6 seconds, during which time the protection circuit operates to eliminate unpleasant noise.

TWIN BASS CONTROLS

Adjust low frequency tone.

- 100Hz: Adjusts frequency band below 400Hz. Control effectiveness at 100Hz is $\pm 10\text{dB}$.
- 50Hz: Provides additional control for the frequency band below 200Hz. Control effectiveness at 50Hz is $\pm 5\text{dB}$.

TONE SWITCH

In the **OFF** (up) position the **BASS** and **TREBLE** controls are bypassed, the amplifier section to operate with a flat frequency response regardless of the tone control settings.

FM TUNING METER

With the **SIGNAL** meter needle deflected to the right, make fine adjustment by centering the **FM TUNING** meter needle (indicating optimum reception).

SIGNAL METER

For AM and FM station tuning.

AM tuning: Tune for maximum deflection of the **SIGNAL** meter needle to the right.

FM tuning: Both the **SIGNAL** and **FM TUNING** meters work together (see **FM TUNING METER**).

FM STEREO INDICATOR

SPEAKER SYSTEM INDICATORS

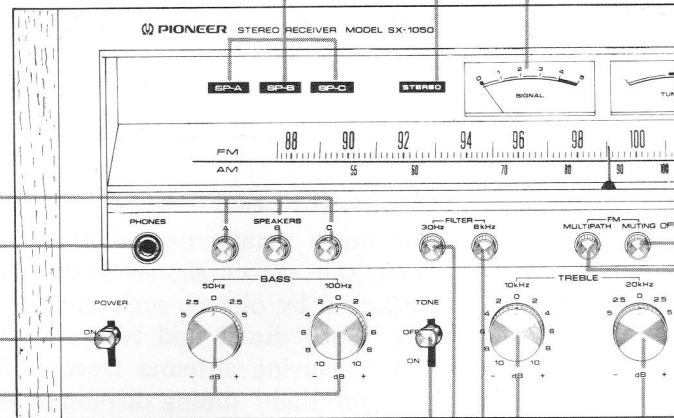

LOW CUT FILTER SWITCH

When low-pitched rumble (from turntable motor or other source) is obtrusive, depress this button to provide 12dB/octave attenuation at frequencies below 30Hz. If no interference is experienced, release this button.

HIGH CUT FILTER SWITCH

When high frequency scratch noise (from worn records or other source) is unpleasant, depress this button to provide 12dB/octave attenuation at frequencies above 8kHz. If there is no interference, release this button.

TUNING KNOB

Select the station and tune for optimum reception by observing the SIGNAL meter for AM stations, and both SIGNAL and TUNING meters for FM stations.

FM MUTING BUTTON

Leave this button undepressed (in the ON position) to suppress unpleasant interstation noise while tuning between stations. Low-strength signals may also be suppressed by this function, so to pick up a weak station depress this button to the OFF position.

PROGRAM SOURCE INDICATORS

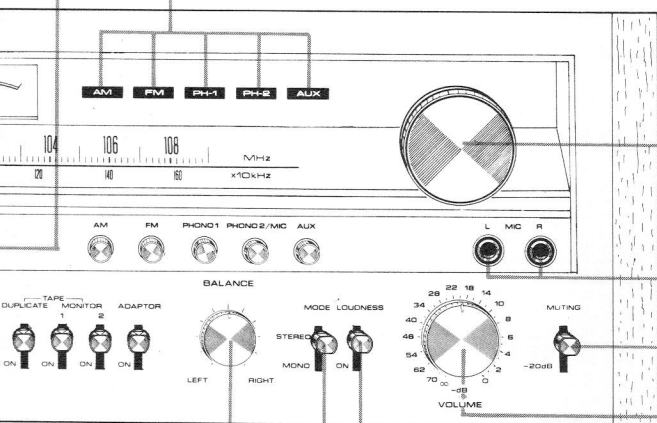

MIC JACKS

Accept standard 6 mm ϕ microphone plugs.

AUDIO MUTING SWITCH - 20dB

Set to -20dB to attenuate the audio output by 20dB. This convenient feature saves having to disturb the VOLUME control, for example when answering the telephone.

VOLUME CONTROL

Adjusts output level of speakers and headphones. Scale is graduated in dB, and when used in conjunction with the MUTING switch, finer and wider range attenuation can be performed. See additional description.

LOUDNESS SWITCH

Set to ON when listening at low volume. The frequency response of the human ear varies according to the listening volume, and the ON position compensates for hearing response by emphasizing the bass and treble.

MODE SWITCH

Set to STEREO for normal stereo operation. When set to MONO, left and right channel signals will be mixed and reproduced monophonically from both speaker systems.

MULTIPATH SWITCH

When selecting the best position for the FM antenna, depress this button so that multipath noise is heard from the speaker systems. For details see page 9 "Orientation". To listen to FM broadcasts, release this button.

TWIN TREBLE CONTROLS

Adjusts high frequency tone.

10kHz: Adjusts frequency band above 2.5kHz. Control effectiveness at 10kHz is ± 10 dB.

20kHz: Provides additional control for the frequency band above 5kHz. Control effectiveness at 20kHz is ± 5 dB.

BALANCE CONTROL

Adjusts the balance between the sound volume from the left and right speaker systems or headphones.

FUNCTION SELECTOR BUTTONS

To select the program source, push each button as follows:
NOTE: Only one FUNCTION button should be depressed at a time.

AM For AM broadcast reception.

FM For FM broadcast reception. The STEREO indicator lights up when the broadcast is in stereo.

PHONO 1 To operate a turntable connected to the PHONO 1 input jacks.

AUX For listening to an audio component (cartridge tape player, TV sound tuner, etc.) connected to the AUX input jacks.

PHONO 2/MIC As above for PHONO 2 jacks, or for reproduction through microphones connected to the MIC jack on the front panel. Note: when microphones are plugged in the turntable connected to the PHONO 2 jacks cannot be used.

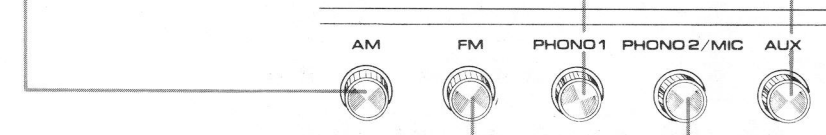

TAPE DUPLICATE SWITCH

Set this switch in the ON (down) position to duplicate or edit a recorded tape using two tape decks.

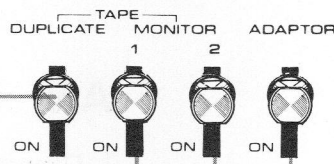

TAPE MONITOR (1, 2) SWITCHES

1 With a tape deck connected to the TAPE 1 jacks (REC and PLAY), either playback or monitoring of a recording in progress are possible.

2 Same as in 1 above, with a tape deck connected to the TAPE 2 jacks (REC and PLAY).

For normal use, leave in the OFF (up) position.

ADAPTOR SWITCH

When employing adaptor components, such as a graphic equalizer adaptor, RG processor, or Dolby NR adaptor, depress this ADAPTOR switch to ON.

Precise volume control

The extremely high power output of the SX-1050 can be finely controlled by combining the calibrated VOLUME control and the MUTING switch. The MUTING switch can also be used to briefly lower the volume when changing records or tapes.

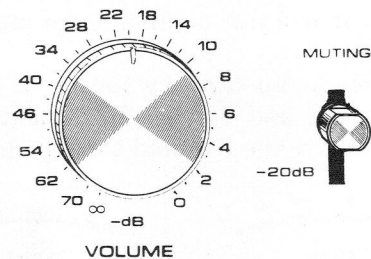

PRIOR TO SWITCHING POWER ON

Before switching on the power, set the various controls as follows:

Release the FM MULTIPATH switch to OFF (up)

Turn the MUTING switch OFF (up)

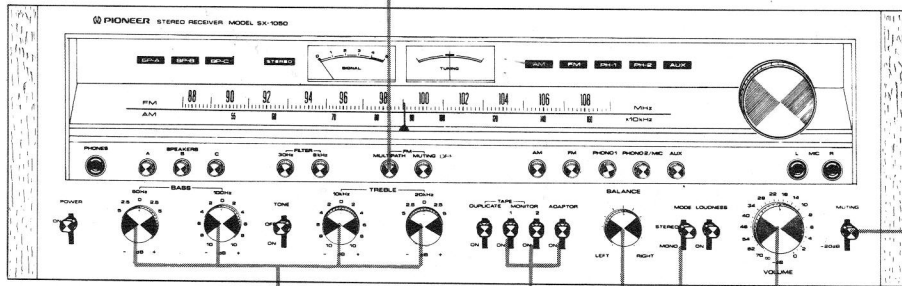

Set the TREBLE and BASS controls to the midway positions (the "0" positions)

Turn the TAPE MONITOR and ADAPTOR switches to OFF (up)

Set the VOLUME control to MIN (fully counterclockwise)

Turn the MODE switch to STEREO (up)

Set the BALANCE control to the midway positions

FM RECEPTION

1. Depress the FM selector button.
2. Set the FM MUTING button to ON.
Note, however, that in areas of low signal strength the signal may be suppressed. In this case only, the FM MUTING should be depressed to the OFF position.
3. Select the station by means of the TUNING knob.

Best reception is obtained when the SIGNAL meter needle deflects to the extreme right, and the TUNING meter needle is exactly in the center, as shown in Fig. 12. If the broadcast is stereophonic, the STEREO indicator lamp will come on; it will not illuminate for monophonic broadcasts.

4. Adjust the sound level by means of the VOLUME control, and use the BASS and TREBLE controls to give the required tone quality.

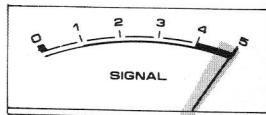

FM Reception

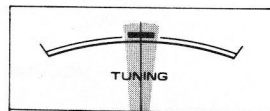

Fig. 12

AM RECEPTION

1. Depress the AM selector button.
2. Turn the TUNING knob to select your station.
Best reception is obtained when the SIGNAL meter needle deflects to the extreme right (Fig. 13).
3. Adjust the VOLUME, BASS and TREBLE controls for the listening level and tone quality of your preference.

NOTE:

If, when listening to either FM or AM broadcasts, listening pleasure is seriously affected by poor sensitivity or strong interference, refer to the section "ANTENNA AND GROUND CONNECTIONS," on page 8 and make any necessary changes.

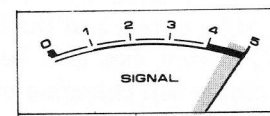

AM Reception

Fig. 13

PLAYING RECORDS

1. Set the FUNCTION selector to either PHONO 1 or PHONO 2/MIC, depending upon which input jacks the turntable is connected to.
2. Operate the turntable to play the record.
3. Adjust the VOLUME, BASS, and TREBLE controls for the listening level and tone quality of your preference.

NOTES:

1. *In order to eliminate the unpleasant noise which can mark the start of a record, set the AUDIO MUTING switch to -20dB, releasing it after the stylus has completed the run-in, and then adjust the VOLUME to give the sound level of your choice.*
2. *The turntable connected to the PHONO 2 jacks can not be used if microphones are connected to the MIC jacks on the front panel.*

USING THE AUX JACKS

To play equipment connected to the AUX jacks, proceed as follows:

1. Set the FUNCTION selector by depressing the AUX button.
2. Operate the attached component.
3. Adjust the VOLUME, BASS, and TREBLE controls for the listening level and tone quality of your preference.

MICROPHONES

1. Connect the microphones to the MIC jacks.
2. Set the FUNCTION selector by depressing the PHONO 2/MIC button.
3. Adjust the sound level by turning the VOLUME control gradually to the right. The midway setting of the BASS and TREBLE controls will usually give best results.

NOTES:

1. *Under certain conditions microphones are liable to give rise to "howling" or feedback noise. Be careful not to raise the volume too high when the microphone is close to the speaker systems or in a room with a great deal of resonance. This tendency can be reduced by setting the TREBLE and BASS controls to their "0" positions, or by switching the TONE switch OFF (up).*
2. *When a microphone has only been connected to one of the microphone jacks (either L or R), sound will only be heard from the corresponding left-hand or right-hand speaker systems as long as the MODE switch is set at STEREO. For the sound to be heard from both speaker systems, the MONO mode should be selected.*
3. *Regardless of the MODE switch setting, only one tape track can be recorded if only one microphone is connected. Therefore only one LEVEL meter will register during recording, and sound will only be heard from one speaker system if played back in the STEREO mode.*

PROTECTION CIRCUIT

For some 3 to 6 seconds after the receiver is switched ON, no sound will be heard. This is due to the operation of protection circuits which are designed to safeguard transistors and speakers from possible damage, due chiefly to switching transients, etc. Should the receiver remain silent for considerably longer than this, switch off and check the speaker system connections. Should the receiver suddenly go silent while you are listening to it, and a continuous series of "clicks" can be heard due to relay contacts opening and closing within the receiver, this can also be an indication of a short circuit in the speaker system connections. Switch off, and re-check the speaker system impedances, etc.

The protection circuit re-sets itself automatically, so that normal operation is resumed as soon as the fault is cured.

EFFECTIVE OPERATION

BASS AND TREBLE TWIN CONTROLS

A twin tone control system is provided which incorporates main and sub controls, as illustrated in Fig. 14. Tone adjustments can be performed in the same manner as with conventional tone controls by using only the main controls. The subcontrols provide the same function as changing the turnover (or roll over) frequency. Approximately 3000 tone combinations can be obtained by using both controls.

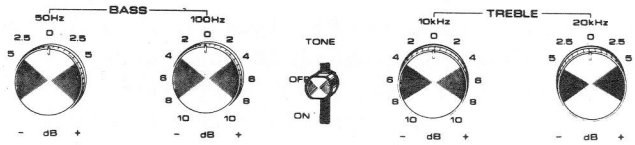
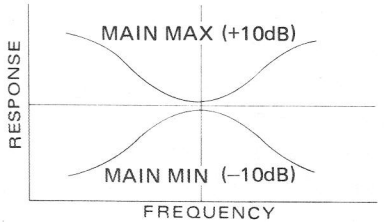
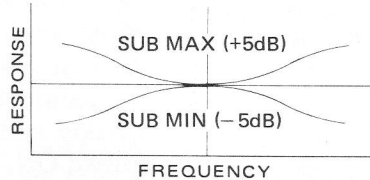

Fig. 14



MAIN Tone control characteristic.

Fig. 15



SUB Tone control characteristic.

Fig. 16

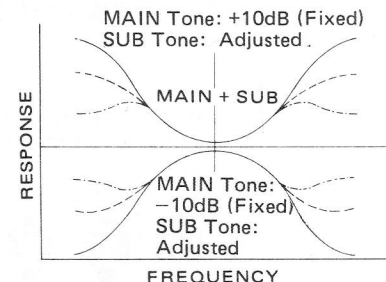

Both Tone control characteristic.

Fig. 17

Typical Applications

- Low frequencies in the 100Hz–150Hz region, which delicately influence bass impression, can be enhanced by a 0.8dB–1.0dB margin (Fig. 18). While retaining an overall flat impression, slightly more weight can be obtained in the low frequency band. Since the opposite adjustment can also be performed, such effects as standing waves and extended reverberations, which can occur in steel framework buildings and lend an unnatural influence, are often improved.
- High frequencies can be adjusted by the twin TREBLE controls to compensate for quavering which often occurs with moving magnet (MM) type phono cartridges. To cite another example, when conventional tone controls are used to enhance high frequencies from records, ultra high frequency peaking can occur from the phono cartridge. This drawback is eliminated by the twin control system, which can enhance 8kHz–10kHz frequencies while maintaining an overall flat response. See Fig. 19.
- Careful adjustment of the twin BASS and TREBLE controls can provide an effect equivalent to enhancing the midrange. This is a useful technique for obtaining a close up of a singer's voice or similar applications. See Fig. 20. Regardless of the twin controls settings, a completely flat response can be obtained at any time by setting the TONE switch to OFF. The delicate effects of the tone controls can thus be confirmed when adjusting them according to the program source.

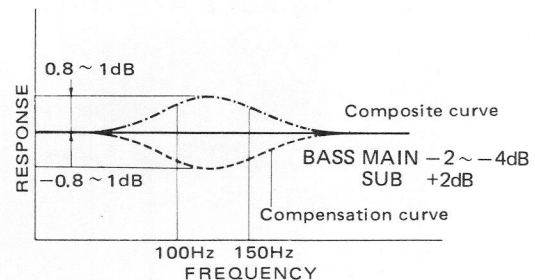

To improve unnatural low frequencies.

Fig. 18

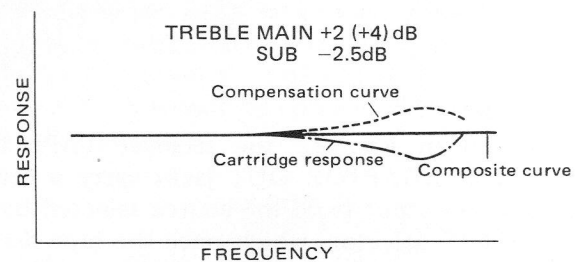

Compensation for high frequency slacking of cartridge.

Fig. 19

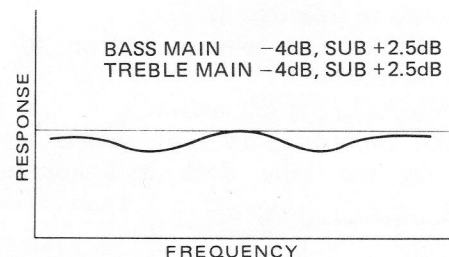

Relatively enhancing the midrange.

Fig. 20

TAPE DECK OPERATIONS

Playback

1. According to the TAPE PLAY (1, 2) or ADAPTOR IN jacks to which the tape deck is connected, either the TAPE MONITOR 1 or 2 switches or the ADAPTOR switch should be set to ON (see Figs. 21 and 22).
2. Operate the tape deck controls for playback.
3. Adjust the VOLUME, BASS, and TREBLE controls for the listening level and tone quality of your preference.

NOTE:

Setting the TAPE MONITOR switch to ON enables tape playback whatever the setting of the FUNCTION selector.

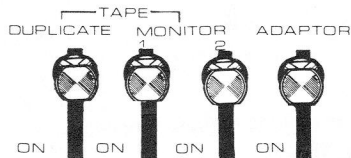

Fig. 21

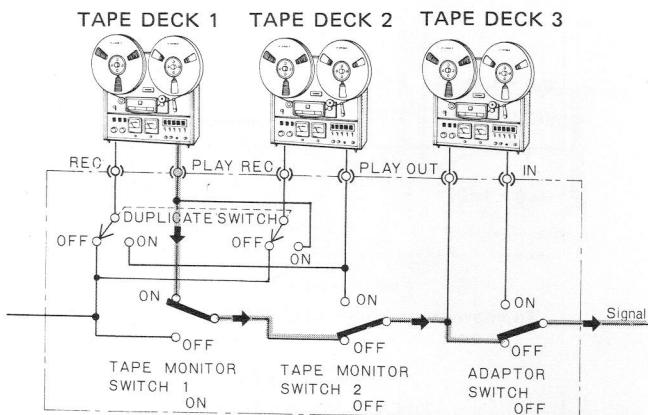

Fig. 22

Recording

As shown in Fig. 23, the receiver TAPE REC (1, 2) and ADAPTOR OUT jacks carry a certain fixed level output from the source selected by the FUNCTION selector, which once the tape deck is connected to the appropriate jacks, enables the selected source to be recorded.

The operation is as follows:

1. Set the FUNCTION selector button for the source to be recorded.
2. Play the selected program source.
3. Adjust the recording level by means of the controls on the tape deck and commence recording.

NOTE:

The receiver VOLUME, BASS, and TREBLE controls are completely inoperative — that is they have no effect on the recorded sound — when recordings are being made.

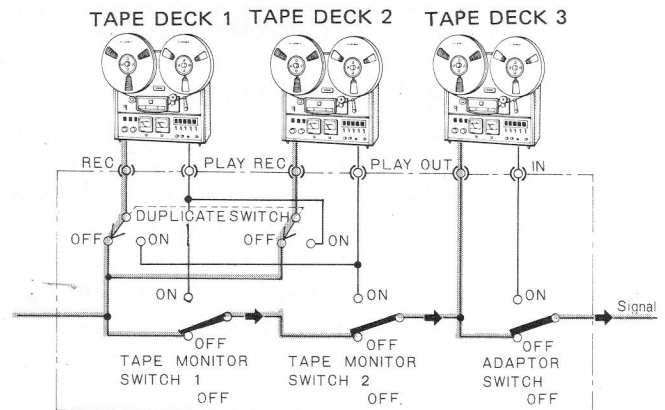

Fig. 23

Tape Monitoring

While a recording is being made on a three-head deck or one equipped with a monitoring facility, the recorded sound can be monitored through the speaker systems if the TAPE MONITOR switch is turned ON.

In this case both recording and playback connections must be made.

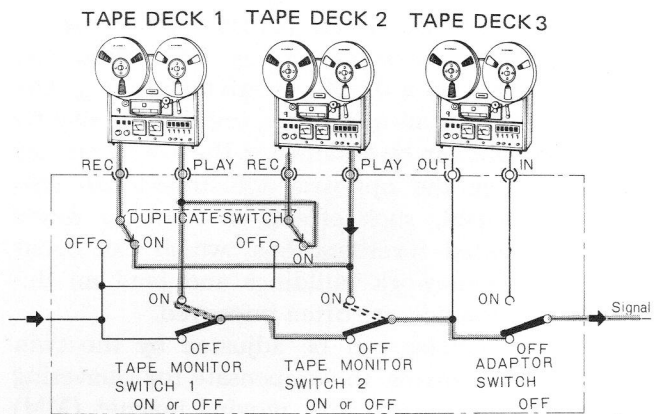

Fig. 24

Duplicating or Editing Recorded Tapes

By using two tape decks, a recording of, say, a complete FM broadcast can be made, and then those items which you want for your permanent "tape library" can be selected and re-recorded onto another tape.

1. Connect the two tape decks as shown in Fig. 24.
2. Set the TAPE DUPLICATE switch to the ON position.
3. Select one of the tape decks (1 or 2) to playback the pre-recorded tape, and use the other tape deck to make the copy recording.
4. When recording with tape deck 1, TAPE MONITOR switch 1 should be switched ON to monitor the recorded sound, and when recording with deck 2, TAPE MONITOR switch 2 should be switched ON for monitoring (refer again to Fig. 24).

ADAPTOR JACKS FOR INCREASED VERSATILITY

DOLBY ADAPTOR

If a Dolby adaptor is connected to the receiver ADAPTOR jacks, not only can FM Dolby broadcasts be played back, but if a tape deck is connected to the adaptor itself, Dolby system recording and playback are available.

Reception of FM Dolby Broadcasts

Dolby system FM broadcasts can be received by making the following connections:

1. Set the DE-EMPHASIS switch to the "25 μ s" position.
2. Connect the Dolby adaptor as shown in Fig. 25.
3. Set the FUNCTION selector to FM by depressing the FM button, and tune in to an FM Dolby system broadcast.
4. Turn the ADAPTOR switch ON.

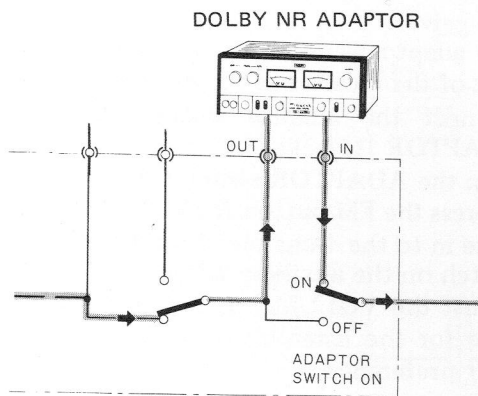

Fig. 25

Dolby Recording

1. As shown in Fig. 26, connect the Dolby adaptor output jacks to the tape deck recording input jacks (LINE INPUT).
2. Select the program source of your choice with the FUNCTION selector.

NOTE:

If you wish to monitor the recorded sound via the Dolby adaptor, turn the ADAPTOR switch ON.

Dolby Playback

1. Connect the tape deck playback output jacks (LINE OUTPUT) to the input jacks of the Dolby adaptor.
2. Turn the ADAPTOR switch ON, and playback your Dolby system recordings.

NOTE:

For detailed instructions on connections, etc., please see the instruction manual provided with your Dolby adaptor.

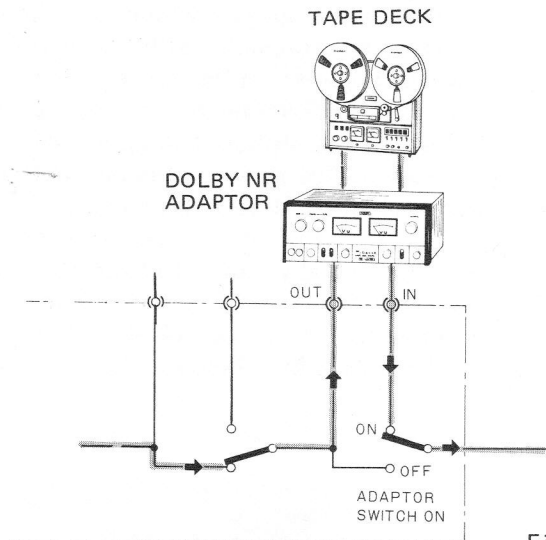

Fig. 26

OTHER ADAPTORS CURRENTLY AVAILABLE

The provision of these convenient adaptor jacks in addition to the normal tape REC/PLAY jacks, enables other sophisticated adaptor units (e.g. a graphic equalizer, RG dynamic processor, etc.) to be connected without forfeiting the full tape monitoring and duplicating facility. When using an adaptor, the program source can be taken from the function selector or the tape deck output terminals. Fig. 27 illustrates an RG dynamic processor connected to the ADAPTOR terminals.

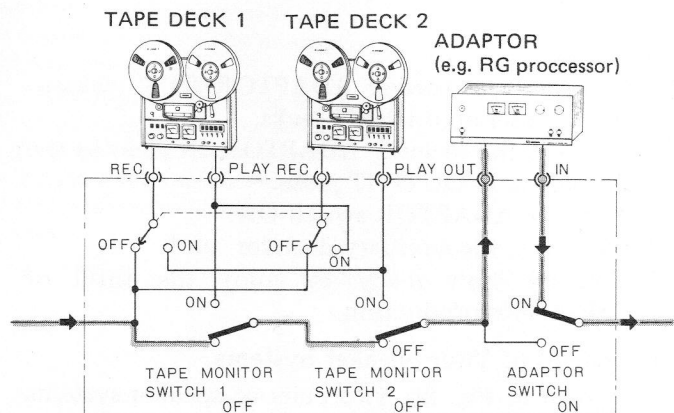

Fig. 27

SETTING UP A 4-CHANNEL SYSTEM

As shown in Fig. 28, a 4-channel system consists of two pairs of speakers, one at the front and the other at the rear, which gives a whole new dimension of realism not attainable with conventional 2-channel stereo. It gives a truer impression of the acoustics of the hall where the recording was made, including the atmosphere and applause.

The unique sense of "presence" of being "actually there" which 4-channel stereo alone can give, has to be experienced before it can be appreciated, and this receiver is ideally suited to form the heart of a 4-channel system, when connected to four speaker systems and a 4-channel decode/power amplifier ("decoder-amp" below) for the rear channels.

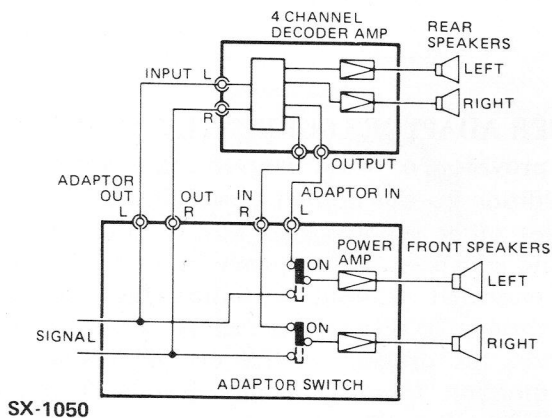

Fig. 28

Operation

1. Connect the receiver ADAPTOR OUT jacks to the decoder-amp INPUT jacks.
2. Connect the receiver ADAPTOR IN jacks to the decoder-amp OUTPUT jacks.
3. Turn the ADAPTOR switch ON.
4. Switch on the auxiliary decoder unit.
5. You are now ready to enjoy the thrill of 4-channel reproduction.

Placement of Your Speaker Systems

As shown in Fig. 30, two pairs of speaker systems are located at the front left and right, and the rear left and right (four in all). Connect the speakers located in FRONT to the receiver, and the REAR speakers to the power amplifier for the rear channels.

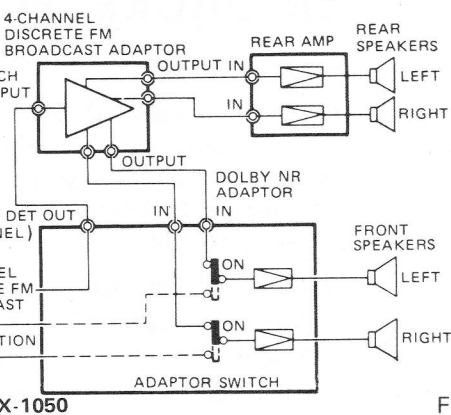

Fig. 29

Receiving 4 channel FM broadcasts

If 4-channel multiplex discrete FM broadcasts are available, the addition of a 4-channel discrete FM broadcast adaptor ("adaptor" below) will enable full 4-channel reproduction of the broadcasts from your receiver.

1. The adaptor is connected to the FM DET. OUT jack of the receiver as shown in Fig. 29.
2. Connect the adaptor output to the receiver ADAPTOR IN jacks.
3. Turn the ADAPTOR switch ON.
4. Depress the FM button for FUNCTION selection.
5. Tune in to the 4-channel discrete FM broadcast.
6. Switch on the auxiliary adaptor unit.
7. Adjust the VOLUME, BASS, and TREBLE controls for the listening level and tone quality of your preference.

NOTE:

For detailed instructions on connections, etc., see the instruction manual supplied with the adaptor.

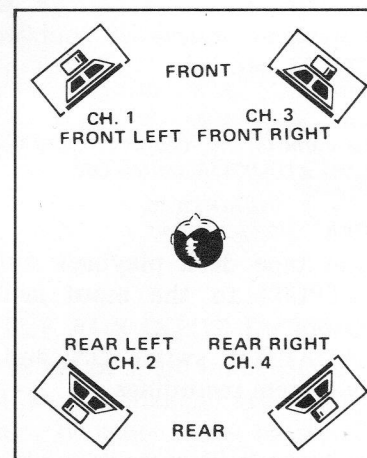

Fig. 30

EMPLOYING PRE OUT AND POWER IN JACKS

USING THE PRE OUT AND POWER IN JACKS

If the connections between the PRE OUT and POWER IN jacks shown in Fig. 31 are removed, the power amplifier and pre-amplifier section, it is possible to use it to drive a separate, high output power amplifier, or to build up a multi-amplifier system.

INDEPENDENT PREAMPLIFIER FUNCTION

The preamplifier section of the SX-1050 can be used independently to drive an external power amplifier. This allows comparison listening between the built-in SX-1050 power amplifier and a home-built or other separate power amplifier.

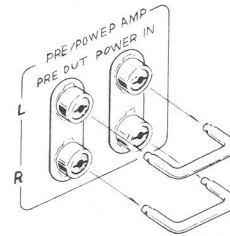

Fig. 31

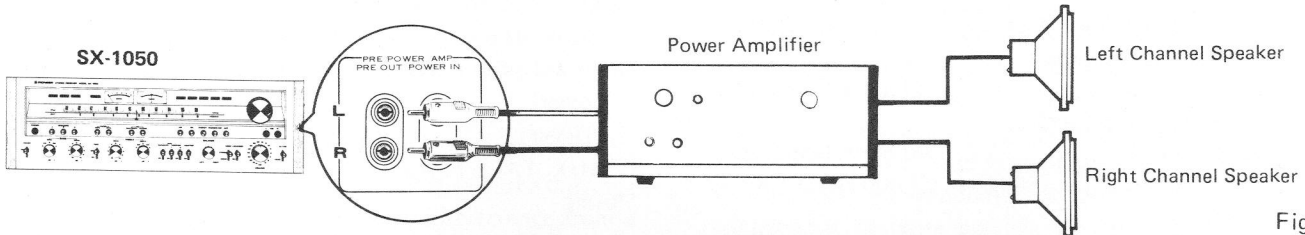

Fig. 32

CONNECTIONS FOR SETTING UP A MULTI-AMPLIFIER SYSTEM

By purchasing an electronic crossover network and one or two additional power amplifiers, a two- or three-way multi-amplifier system can be constructed. This splits up the audible frequency range into different frequency bands, to operate amplifiers and speakers ideally suited to each band. The result are reduced intermodulation distortion and improved damping and crossover characteristics. Use of the multi-amplifier system is as follows:

1. Remove both of the plugs bridging the PRE OUT and POWER IN jacks.
2. Connect the PRE OUT jacks to the input jacks of the crossover network.

3. Connect the POWER IN jacks to the LOW range jacks of the crossover network.
4. Connect the HIGH range output jacks of the crossover network to the input jacks of a separate power amplifier for the high frequency range.
5. Connect the speakers for the lower frequencies to the receiver, and those for the higher frequencies to the separate amplifier.

The levels of the different frequency ranges are adjustable by the crossover network. For detailed instructions on the use of the crossover network, please refer to the instruction manual provided with it.

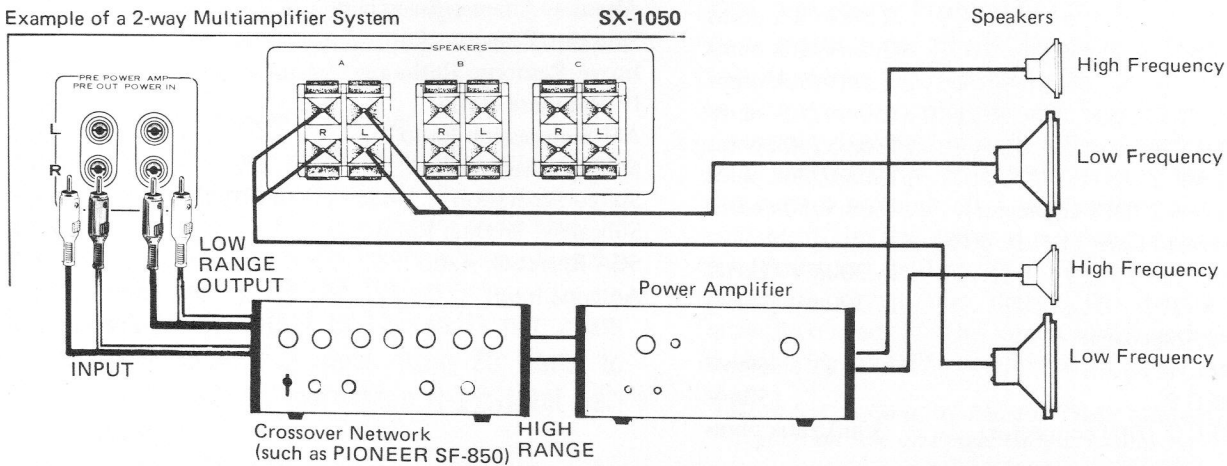

Fig. 33

SPECIFICATIONS

Semiconductors

FETs	4
ICs	5
Transistors	79
Diodes	49

Power Amplifier Section

Continuous power output of 120 watts*per channel min. RMS, at 8 ohms or 170 watts*per channel at 4 ohms from 20 Hertz to 20,000 Hertz with no more than 0.1%total harmonic distortion.

Total Harmonic Distortion (20 Hertz to 20,000 Hertz, from AUX)

Continuous Rated Power Output. . . No more than 0.1% 60 watts per channel power

output, 8 ohms No more than 0.05%

1 watt per channel power

output, 8 ohms No more than 0.06%

Intermodulation Distortion (50 Hertz : 7,000 Hertz = 4 : 1, from AUX)

Continuous Rated Power Output. . . No more than 0.1% 60 watts per channel power

output, 8 ohms No more than 0.05%

1 watt per channel power

output, 8 ohms No more than 0.06%

Frequency Response 7Hz to 90,000Hz ± 0.5 dB

Input Sensitivity/Impedance

POWER AMP IN 1 V/50k ohms

Output

Speaker A, B, C, A+B, B+C, A+C

Headphone Low Impedance

Damping Factor

(20Hz to 20,000Hz, 8 ohms) 25

Hum and Noise (IHF, short-circuited, A Network) . . 100dB

Preamplifier Section

Input Sensitivity/Impedance

PHONO 1 2.5mV/50k ohms

PHONO 2 2.5mV/50k ohms

MIC 6.5mV/50k ohms

AUX 150mV/50k ohms

TAPE PLAY 1 150mV/50k ohms

TAPE PLAY 2 150mV/50k ohms

TAPE PLAY 2 (DIN connector) . . . 150mV/50k ohms

PHONO Overload Level (T.H.D. 0.1%)

PHONO 1 300mV (1kHz)

PHONO 2 300mV (1kHz)

Output Level/Impedance

TAPE REC 1 150mV

TAPE REC 2 150mV

TAPE REC 2 (DIN connector) 30mV/80k ohms

PRE OUT 1V/1k ohms

Total Harmonic Distortion

(20Hz to 20,000Hz, 1V output) . . No more than 0.05%

Frequency Response

PHONO (RIAA equalization). .30Hz to 15,000Hz ± 0.2 dB

AUX, TAPE PLAY 10Hz to 50,000Hz ± 1 dB

Tone Control

BASS MAIN ± 10 dB (100Hz)

SUB ± 5 dB (50Hz)

TREBLE MAIN ± 10 dB (10kHz)

SUB ± 5 dB (20kHz)

Filter

LOW 30Hz (12dB/oct.)

HIGH 8kHz (12dB/oct.)

Loudness Contour (Volume control set

at -40dB position) +6dB (100Hz), +3dB (10kHz)

Hum and Noise (IHF, short-circuited, A Network, rated power)

PHONO 75dB

AUX, TAPE PLAY 90dB

Muting -20dB

FM Section

Usable Sensitivity MONO 10.3dBf

STEREO 15.7dBf

Usable Sensitivity (IHF '58) 1.8 μ V

50dB Quieting Sensitivity MONO 14.5dBf

STEREO 36.0dBf

Signal to Noise Ratio at 65dBf . . MONO 78dB

STEREO 73dB

Distortion at 65dBf 100Hz MONO 0.1%

STEREO 0.25%

1kHz MONO 0.1%

STEREO 0.25%

6kHz MONO 0.4%

STEREO 0.4%

Frequency Response 30Hz to 15,000Hz ± 0.3 dB

Capture Ratio 1.0dB

Alternate Channel Selectivity 80dB

Spurious Response Ratio 100dB

Image Response Ratio 85dB

IF Response Ratio 100dB

AM Suppression Ratio 55dB

Muting Threshold 11dBf

Stereo Separation . . 45dB (1kHz), 30dB (30Hz ~ 15kHz)

Subcarrier Product Ratio 73dB

SCA Rejection Ratio 73dB

Antenna Input 300 ohms balanced

75 ohms unbalanced

CONDITIONS FREQUENTLY MISTAKEN FOR MALFUNCTION

If your stereo appears to malfunction, first check such things as the fuse, controls (power switch, function selector, tape monitor, etc.) and connecting cords (components connected correctly).

Noise: There are a variety of noises relating to the operation of a hi-fi unit. These are generally divided into two types; (1) the unit is faulty (a transistor or part has deteriorated) and (2) an external source is adding to the unit.

When a hi-fi unit produces an unpleasant noise, it is often assumed that the unit is faulty, but statistical records indicate that the majority of noises pro-

duced in hi-fi acoustic units result from external sources of noise: Due to the inherent high sensitivity and the high fidelity in reproduction, the unit amplifies and reproduces extraneous noises, however small, into definite output noise. If your receiver produces a noise, check according to the following table and trace out the source of noise for the appropriate corrective action.

	SYMPTOM	SUSPECTED SOURCE OF NOISE	DIAGNOSIS AND REMEDY
WHEN LISTENING TO BROADCASTS	Continuous or intermittent buzzing noise.	<ul style="list-style-type: none"> • Static (lightning) • Fluorescent lamp, motor, or thermostat may be in use in house or in the vicinity of the house. 	In many cases, it is very difficult to remove the source of noise. In order to make the radio input larger than the noise level, set up a good outdoor antenna and make a complete grounding.
	When a station is tuned in, hum is mixed in the program.	<ul style="list-style-type: none"> • Poor fluorescent lamp, motor, or electric heater may be in use in house or near the house. 	Reversing the line plug may occasionally alleviate this noise problem. Usually it is very difficult to eliminate the noise.
	Hissing sound noise in AM (medium wave) reception.	<ul style="list-style-type: none"> • The frequency of an adjacent station is interfering with that of the station being tuned in (10kHz beat interference). • TV set is on in the same house with the receiver. 	Impossible to remove such interference. If the cause of such noise is the TV set, increase the distance between the TV set and receiver.
	Static noise (in particular, when automobiles run close to the house).	<ul style="list-style-type: none"> • White noise generated from automobile engines. • High frequency sewing machine or welding machine being used near your house. 	In an area surrounded by hills or high buildings, the FM input signals are very weak. Thus the noise limiter in the circuit loses its function. Set up an FM outdoor antenna having many director elements.
	Reception of FM stereo program contains more noise than FM mono program.	<ul style="list-style-type: none"> • Note that the service area covered by an FM stereo broadcast is about 50% of that of a regular mono broadcast. 	Increasing the FM input signal may alleviate this problem. Use an exclusive FM outdoor antenna instead of the indoor T-type antenna.
WHEN PLAYING RECORDS	Hum or buzz. When switched to radio reception, the noise disappears.	<ul style="list-style-type: none"> • Poor connection of shielded wire. (a) • Jack connection is loose. (b) • Line cord of fluorescent lamp passes near the shielded wire. (c) • Poor grounding. (d) • Ham transmitting station or TV transmitting station is near your house. (e) 	Correct the conditions stated in (a), (b), (c) or (d). In case of (e), report it to an official authority.
	Output tone quality is poor and mixed with noise. Treble is not clear.	<ul style="list-style-type: none"> • Stylus is worn. (a) • Record is worn. (b) • Dust adhering to stylus. (c) • Stylus is improperly mounted. (d) • Stylus pressure is not correct. (e) • The TREBLE level is too high. 	Check (a) through (e) and correct the condition. Lower the TREBLE level.
	In playing a record, increasing the volume causes howling.	<ul style="list-style-type: none"> • Distance between the turntable and the speakers is too short. • The turntable or speakers supports are unstable. 	Increase the distance or rearrange the installation of the unit and speakers. (Installing the turntable on a firm, solid stand may alleviate this problem.) Do not enhance the BASS sound level excessively.
WHEN USING MICROPHONE	Howling occurs	<ul style="list-style-type: none"> • Feed back between microphone and speakers. 	<ul style="list-style-type: none"> • Keep microphone away from speakers • Do not set the VOLUME control too high. • Set BASS and TREBLE controls to center positions.

PIONEER ELECTRONIC CORPORATION

4-1, Meguro 1-Chome, Meguro-ku, Tokyo 153, Japan

U.S. PIONEER ELECTRONICS CORPORATION

75 Oxford Drive, Moonachie, New Jersey 07074, U.S.A.

PIONEER ELECTRONIC (EUROPE) N.V.

Luithagensteenweg no. 9, 2030 Antwerp, Belgium

PIONEER ELECTRONICS AUSTRALIA PTY. LTD.

178-184 Boundary Road, Braeside, Victoria 3195, Australia

Printed in Japan

<ARB-163-0>