

# SERVICE MANUAL

## AM/FM STEREO RECEIVER **SX-838** KCU, F, GN

**NOTE:**

MODEL SX-838 COMES IN THREE VERSIONS DISTINGUISHED AS FOLLOWS:

Round label on rear panel	Voltage	Type
KCU	120V only	UL (U.S.A.) and CSA (Canada) approved
F	5-position selector	General export model
GN	220V only	SEMCO (Sweden), NEMCO (Norway) and DEMCO (Denmark) approved

 **PIONEER®**

# CONTENTS

## About 220V only model labeled "GN"

This model whose rear panel is labeled "GN" circular mark operates only on 220V, substantially in its circuit design from two other models. When repairing this model, please see the manual on page 75 and the followings which include such items as Circuit connection diagram, Miscellaneous parts list, Schematic diagram of power supply circuit assembly, P.C. board pattern and its parts list.

Before servicing, also please do not fail to check to see if the "GN" mark is labeled on the rear panel.

1.	SPECIFICATIONS	3
2.	FRONT PANEL FACILITIES	5
3.	CONNECTION DIAGRAM	7
4.	BLOCK DIAGRAM	9
5.	CIRCUIT DESCRIPTION	11
6.	PACKING METHOD AND PART NUMBERS	12
7.	LEVEL DIAGRAM	13
8.	DISASSEMBLY	14
9.	PARTS AND P.C. BOARD LOCATIONS	15
10.	DIAL CORD STRINGING	17
11.	ALIGNMENT PROCEDURE	
11.1	English	18
11.2	German	22
12.	EXPLODED VIEW AND PARTS LIST	26
13.	SCHEMATIC DIAGRAMS, P.C. BOARD PATTERNS AND PARTS LIST	
13.1	Circuit Connection Diagram and Miscellaneous Parts	33
13.2	Tuner Assembly (AWE-041)	37
13.3	Equalizer Amplifier Assembly (AWF-011)	43
13.4	Microphone Amplifier Assembly (AWM-064)	46
13.5	Control Amplifier Assembly (AWG-029)	48
13.6	Power Amplifier Assembly (AWH-031)	53
13.7	Protection Circuit Assembly (AWM-025)	58
13.8	Power Supply Circuit Assembly (AWR-055)	61
13.9	Switch & Volume Assembly (AWX-070)	64
13.10	Switch Circuit Assembly (AWS-073)	67
13.11	Switch Circuit Assembly (AWS-065)	70
13.12	Switch Circuit Assembly (AWS-066)	72
13.13	Switch Circuit Assembly (AWS-074)	73
13.14	Switch Circuit Assembly (AWS-075)	74
13.15	5P Connector Assembly (AWX-062)	74

**14. SCHEMATIC DIAGRAMS, P.C. BOARD PATTERN AND PARTS LIST  
FOR 220V ONLY MODEL**

**14.1 Circuit Connection Diagram and Miscellaneous Parts . . . . . 75**  
**14.2 Power Supply Circuit Assembly (AWR-064) . . . . . 79**



# 1. SPECIFICATIONS

## SEMICONDUCTORS

FETs .....	4
ICs .....	4
Transistors .....	43
Diodes .....	24

## AMPLIFIER SECTION

Continuous Power Output 20Hz~20kHz (Both channels driven).....	50W + 50W (8Ω) 60W + 60W (4Ω)
1kHz .....	55W + 55W (8Ω) 70W + 70W (4Ω)
Harmonic Distortion (20Hz~20kHz Continuous Power Output) .....	Less than 0.3%
(1W+1W, Power Output)...	Less than 0.05%
Intermodulation Distortion (Continuous Power Output) .....	Less than 0.3%
(1W+1W, Power Output)...	Less than 0.05%
Power Bandwidth (IHF, Both channels driven) .....	5Hz~40kHz (T.H.D. 0.3%)
Frequency Response .....	10Hz~70kHz
Input Sensitivity/Impedance POWER AMP IN .....	1V/50kΩ
Output Speaker .....	A, B, C, A + B, A + C, B + C (4Ω~16Ω)
Headphone .....	4Ω~16Ω
Damping Factor (1kHz, 8Ω) .....	More than 45
Hum & Noise (IHF, short-circuited, A Network) .....	More than 110dB
Residual Hum & Noise (8Ω, Pre & Power amplifier) .....	Less than 1mV

## PREAMPLIFIER SECTION

Input Sensitivity/Impedance PHONO 1 .....	2.5mV/50kΩ
PHONO 2 .....	2.5mV/50kΩ
PHONO Overload Level (rms/p-p) .....	170mV/480mV
MIC .....	2.0mV/50kΩ
AUX .....	150mV/80kΩ
TAPE PB 1, 2 .....	150mV/80kΩ
TAPE PB 2 (DIN connector) .....	150mV/80kΩ
Output Level/Impedance TAPE REC 1, 2 .....	150mV
TAPE REC 2 (DIN connector) .....	30mV/80kΩ
PREOUT .....	1V/2kΩ
Harmonic Distortion (20Hz~20kHz) .....	Less than 0.1%
Frequency Response PHONO (RIAA equalization) ....	30Hz~15kHz ±0.3dB
AUX, TAPE PB .....	15Hz~40kHz $\pm_{-1}^{+0.5}$ dB
Tone Control BASS .....	±6dB (100Hz), ±10dB (100Hz) TURNOVER FREQUENCY: 200Hz, 400Hz
TREBLE .....	±7dB (10kHz), ±11dB (10kHz) TURNOVER FREQUENCY: 5kHz, 2.5kHz
Filter LOW CUT .....	-8dB (50Hz) 6dB/oct.
HIGH CUT .....	-9dB (10kHz) 6dB/oct.
Loudness Contour (Volume control set at -40dB position) .....	+8dB (100Hz), +4dB (10kHz)
Hum & Noise (IHF, short- circuited, A Network)	
PHONO .....	More than 70dB
MIC .....	More than 65dB
AUX, TAPE PB .....	More than 95dB
Muting .....	-20dB

## FM SECTION

Usable Sensitivity (IHF) ..	1.8μV
Capture Ratio (IHF) .....	1.0dB
Selectivity (IHF) .....	80dB
Signal-to-Noise Ratio ....	70dB
Image Rejection (98MHz) .....	85dB
IF Rejection (98MHz).....	100dB
Spurious Rejection .....	100dB
AM Suppression .....	55dB
Harmonic Distortion MONO .....	Less than 0.2%
STEREO .....	Less than 0.4%
Frequency Response .....	20Hz~15kHz $\pm_{-2.0}^{+0.2}$ dB 50Hz~10kHz $\pm_{-0.5}^{+0.2}$ dB
Stereo Separation 1kHz..	More than 40dB
50Hz~10kHz .....	More than 30dB
Sub Carrier Suppression .	65dB
Antenna Input .....	300Ω Balanced 75Ω Unbalanced
Muting .....	ON-OFF

## AM SECTION

Sensitivity (IHF, Ferrite antenna).....	300μV/m
(IHF, Ext. antenna).....	15μV
Selectivity .....	40dB
Signal-to-Noise Ratio ....	50dB
Image Rejection .....	65dB
IF Rejection .....	85dB

## MISCELLANEOUS

Power Requirements .....	AC 120V 60Hz or 110, 120, 130, 220 and 240V (switchable) 50/60Hz
Power Consumption .....	240W (UL approved model only) 350W (5-line voltage model only)
Dimensions .....	520(W)x175(H)x420(D)mm 20-1/2 x 6-7/8 x 16-9/16 in.
Weight Without Package..	16.2kg (35lb 10oz)
With Package .....	20.3kg (44lb 11oz)

## FURNISHED PARTS

FM T-type Antenna .....	1
Operating Instructions ...	1
Fuse 4A .....	1
2A .....	1 (5 line voltage model only)

## 2. FRONT PANEL FACILITIES

### SIGNAL METER

For AM and FM station tunings.

**AM tuning:** Tune the dial pointer so that the SIGNAL meter needle comes to the extreme right.

**FM tuning:** Both the SIGNAL and FM TUNING meters work together. The optimum point of the SIGNAL meter needle is the same as in AM tuning. Then use the FM TUNING meter.

### SPEAKER BUTTONS

Each of speaker systems A, B, and C is connected to each of output terminals A, B, and C.

By pushing the following:

SPKR-A . . . . Speaker systems A into operation  
 SPKR-B . . . . Speaker systems B into operation  
 SPKR-C . . . . Speaker systems C into operation

### NOTES:

1. When any two pairs of the buttons (A + B, B + C, C + A) are depressed, the corresponding pairs of speaker systems will come into operation. However, operating all three buttons even though depressed at the same time is not possible.
2. Only when listening through headphones, press again the SPKR button(s) in use to OFF (undepressed) from the ON position (pressed).

### POWER SWITCH

Turn this switch ON but wait for some 3 to 6 seconds, during the silence of which the protection circuit eliminates the unpleasant noise not imputed to a receiver fault.

### PHONES OUTPUT JACKS

Accepts stereo headphones.

### BASS CONTROL

Clockwise rotation gives stronger emphasis of the bass range below the turnover frequency (which is selected by the BASS TURNOVER switch). Counterclockwise rotation reduces bass response. This control knob has click-stops.

### BASS TURNOVER SWITCH

This switch selects the frequency below which the bass tone control will begin to act. This "turnover" frequency can be set at 400Hz or 200Hz, to match the characteristics of the room, the program material, or your personal listening preferences.

### LOW CUT, HIGH CUT BUTTONS

**LOW** . . . . . When the low-pitched rumble (turntable motor or other source) is obtrusive, depress the LOW CUT button to ON. In no interference, leave it undepressed (OFF).

**HIGH** . . . . . When the high frequency scratch noise (records or other source) is much, depress this button to ON. In no interference, leave it undepressed (OFF).

### FM TUNING METER

While getting the SIGNAL meter needle going to the right, make fine adjustment with the FM TUNING meter whose needle comes to the center (indicating the optimum reception).

### FM STEREO INDICATOR

### MODE BUTTON

Leave this button undepressed (if necessary, depress this to release it when already depressed) for STEREO playback. For MONO playback, depress it. In this case stereo signals for left and right channels will be mixed into mono signal which will be heard from the center of both speaker systems.

### TUNING KNOB

### FM MUTING BUTTON

Leave this button undepressed (in the ON position) while tuning in FM stations. Inter-station noise may interfere with FM reception while tuning between stations. To suppress this noise, leave the MUTING button undepressed (in the ON position). If the low signal strength is due to distance from the transmitter or other influences, depress this button, at which the weak station will be heard with the MUTING "OFF."

### LOUDNESS BUTTON

Depress this button to listen at low volume. The human ear's frequency response varies according to the listening volume. The depressed button compensates for hearing response with emphasis on the bass and treble.

### FUNCTION SELECTOR BUTTONS

For selecting the program source, push each button as follows:

- AM . . . . . For AM broadcast reception.
- FM . . . . . For FM broadcast reception. The STEREO indicator lights up when the broadcast is in stereo.
- PHONO 1 . . . . For operating a turntable connected to the PHONO 1 input jacks.
- PHONO 2 . . . . For operating a turntable connected to the PHONO 2 input jacks.
- MIC . . . . . For using a microphone. Not possible to mix with other program source.
- AUX . . . . . For listening to audio equipment (cartridge tape player, TV sound tuner, etc.) connected to the AUX input jacks.

### MIC INPUT JACK

Accepts the plug of the microphone.

### VOLUME CONTROL

Governs both the volume of sound outputs from the speaker systems and from the headphones.

### BALANCE CONTROL

Adjusts the balance between the sound volume from the left and right speaker systems.

### DOLBY NR ADAPTOR SWITCH

When employing Dolby Noise Reduction Adaptor depress this DOLBY NR ADAPTOR to ON.

### TAPE MONITOR (1, 2) SWITCHES

Monitor the recorded sound while recording with a tape deck. Also possible to play back tapes as follows:

- 1 . . . . . With a tape deck connected to the TAPE 1 jacks (REC and PB), either monitoring of recording in progress of playing back is possible.
- 2 . . . . . With a tape deck connected to the TAPE 2 jacks (REC and PB or REC/PB connector), the same as in 1 above is possible.

### TREBLE TURNOVER SWITCH

This switch selects the frequency above which the treble tone control will begin to act. This "turnover" frequency can be set at 2.5kHz or 5kHz, to match the characteristics of the room, the program material, or your personal listening preferences.

The effect of the tone controls and turnover switches is illustrated in the below.

### TREBLE CONTROL

Clockwise rotation gives stronger emphasis of the high range above the turnover frequency (selected by the TREBLE TURNOVER switch). Counterclockwise rotation reduces high-range response. This control knob has click-stops.

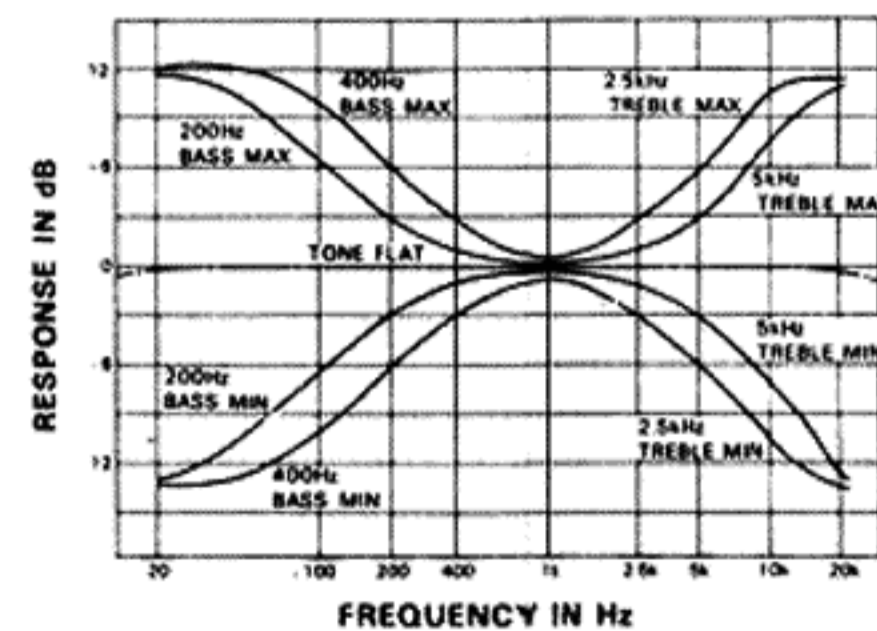

### REC SELECTOR SWITCH

Each setting this switch to FM, PHONO and DUPLICATE permits recording on tape of the tape deck connected to the TAPE 1 terminals of the SX-838. Recording from speaker systems can be made in the ordinary manner only when this switch is set to SOURCE.

- FM:** FM broadcasts can be recorded.
- PHONO:** Disc records on the turntable can be recorded.
- SOURCE:** For all other modes of operation such as record playing, radio reception, etc.
- DUPLICATE:** Recorded tape can be duplicated or edited with two tape decks.

### AUDIO MUTING BUTTON -20dB

Depress this button to mute the audio input to -20dB. No need to turn down the VOLUME control on each occasion for your convenience.

### 3. CONNECTION DIAGRAM

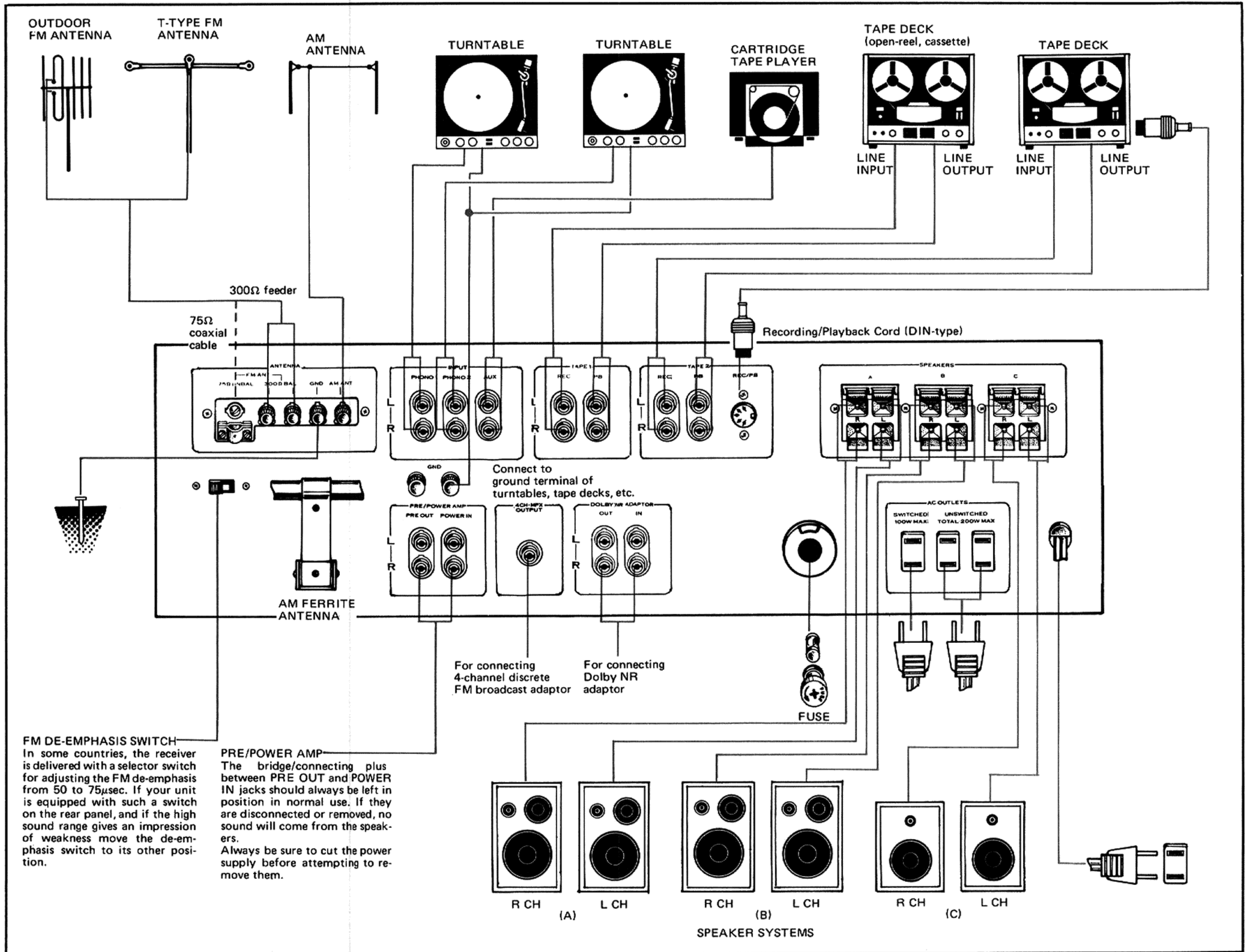

# 4. BLOCK DIAGRAM

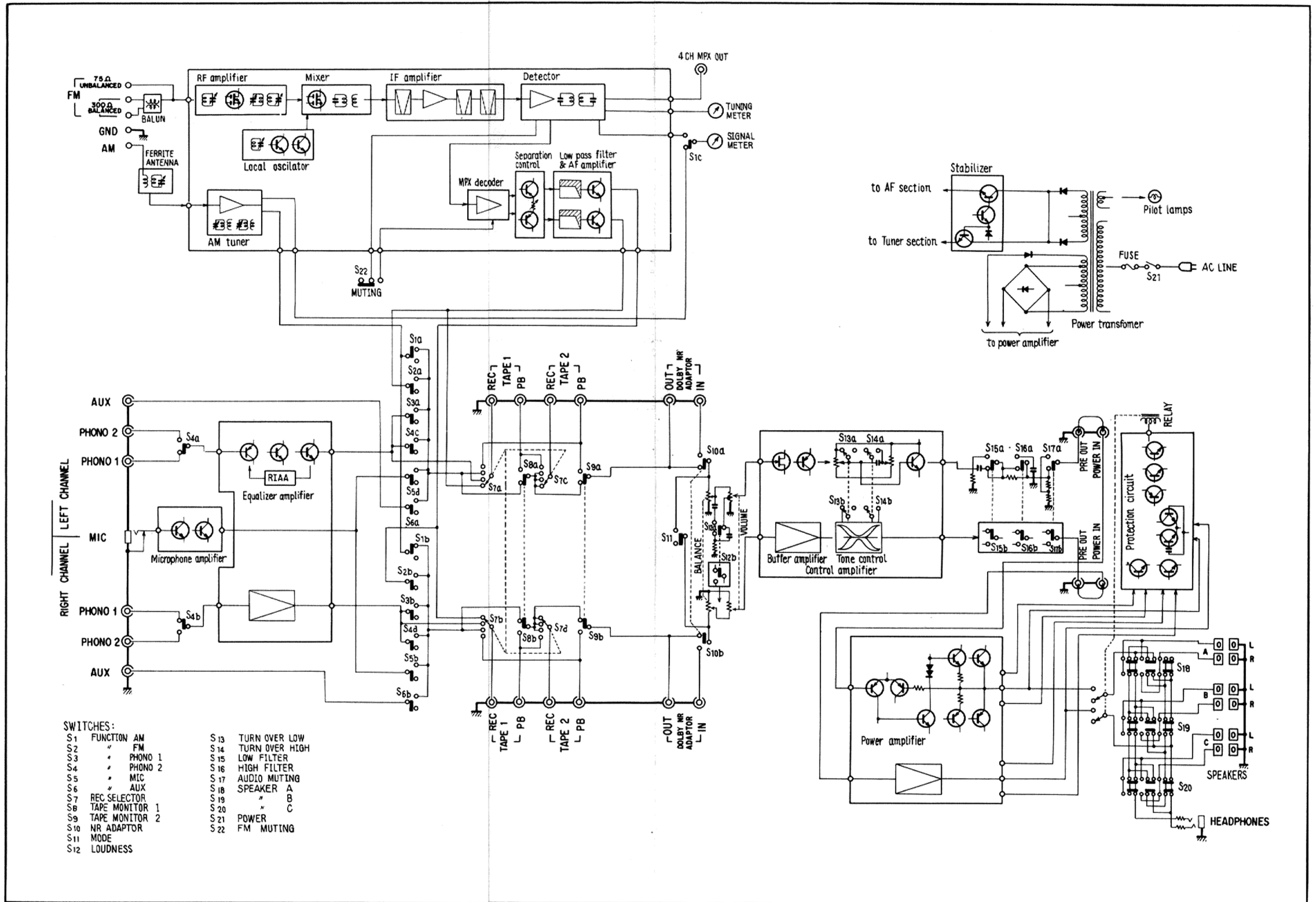

## 5. CIRCUIT DESCRIPTION

### Signal Path

1. The FM broadcast signal waveform from the antenna is fed to the two dual-gate MOS field-effect transistor in the front end section for radio frequency amplification. This signal is converted into an intermediate frequency by the dual-gate MOS FET mixer stage in combination with the signal from the local oscillator.
2. The intermediate frequency signal, converted within the front end section, is fed to three ceramic filters and two ICs, where it is tuned, amplified, and detected, becoming a audio frequency (composite) signal.  
The composite signal following detection is fed to the 4CH MPX terminal jack and the multiplex decoder stage.
3. The multiplex decoder stage uses one IC for three functions: to demodulate the composite signal into the left and right channel stereo signals, to operate the automatic mode switching between stereo/mono, and to switch the stereo indicator lamp appropriately. The decoding system uses a phase locked loop (PLL) circuit, which assures continuous stable operation and excellent stereo separation with low susceptibility to external noise (such as car ignition noise) and ambient temperature changes.  
After decoding, the signal is fed to four transistors and one LC filter, where the residual carrier component (38kHz, 19kHz, and SCA) is rejected, and then to the audio amplifier section.
4. The FM muting circuit is an electronic switch incorporated into the IC, so that the demodulated circuit is switched off and on in the IC.
5. The AM tuner section employs one monolithic IC which functions as radio frequency amplifier, frequency converter; local oscillator, intermediate frequency amplifier, and detector. The output is a pure audio signal.
6. The signals which are applied to the PHONO 1 and 2 terminal jacks are selected by the FUNCTION switch before being fed to the first stage of the three-stage direct-coupled equalizer amplifier by which the signals are amplified.
7. The output from the equalizer amplifier, together with that from the AUX terminal jacks, the audio signal from the AM tuner, the audio signal from the FM tuner, and the amplified signal from MIC terminal jack; are all selected by the FUNCTION switch, and pass through the switch circuits for REC SELECTOR, TAPE MONITOR, DOLBY NR ADAPTOR, and the circuits for BALANCE and VOLUME controls, before being fed to the control amplifier.
8. The control amplifier has an extremely high input impedance, using an field-effect transistor. This greatly reduces the influence of the performance inherent in equipment connected externally.  
The output from this FET circuit is into the tone control circuit, and employed with turn over switches.
9. The control amplifier output is fed to the power amplifier after passing through the LOW FILTER, HIGH FILTER, and AUDIO MUTING circuits.  
The power amplifier is a differential amplifier of the first stage and pure complementary circuit design with balanced positive and negative power supply.
10. The power amplifier output is fed to the three push buttons which form the SPEAKER switch. This selects A, B, and C speaker system terminal connection.  
If all three speaker systems were to be connected simultaneously, the effective speaker impedance might be less than  $4\Omega$ . To guard against this possibility, when all three buttons are depressed together, all three systems are disconnected from the amplifier.
11. The protective circuit which guard against DC potentials at the power amplifier output junctions, against speaker complex load impedances less than  $4\Omega$ , and shorts across the speaker terminals. Their operation is such that, under the corresponding abnormal condition, a relay acts to separate the output junction and the output circuit. Further, these protective circuits are also help to mute the unwanted signal which immediately follows switching the POWER switch ON, and to immediately disconnect the output after switched OFF.

# 6. PACKING METHOD AND PART NUMBERS

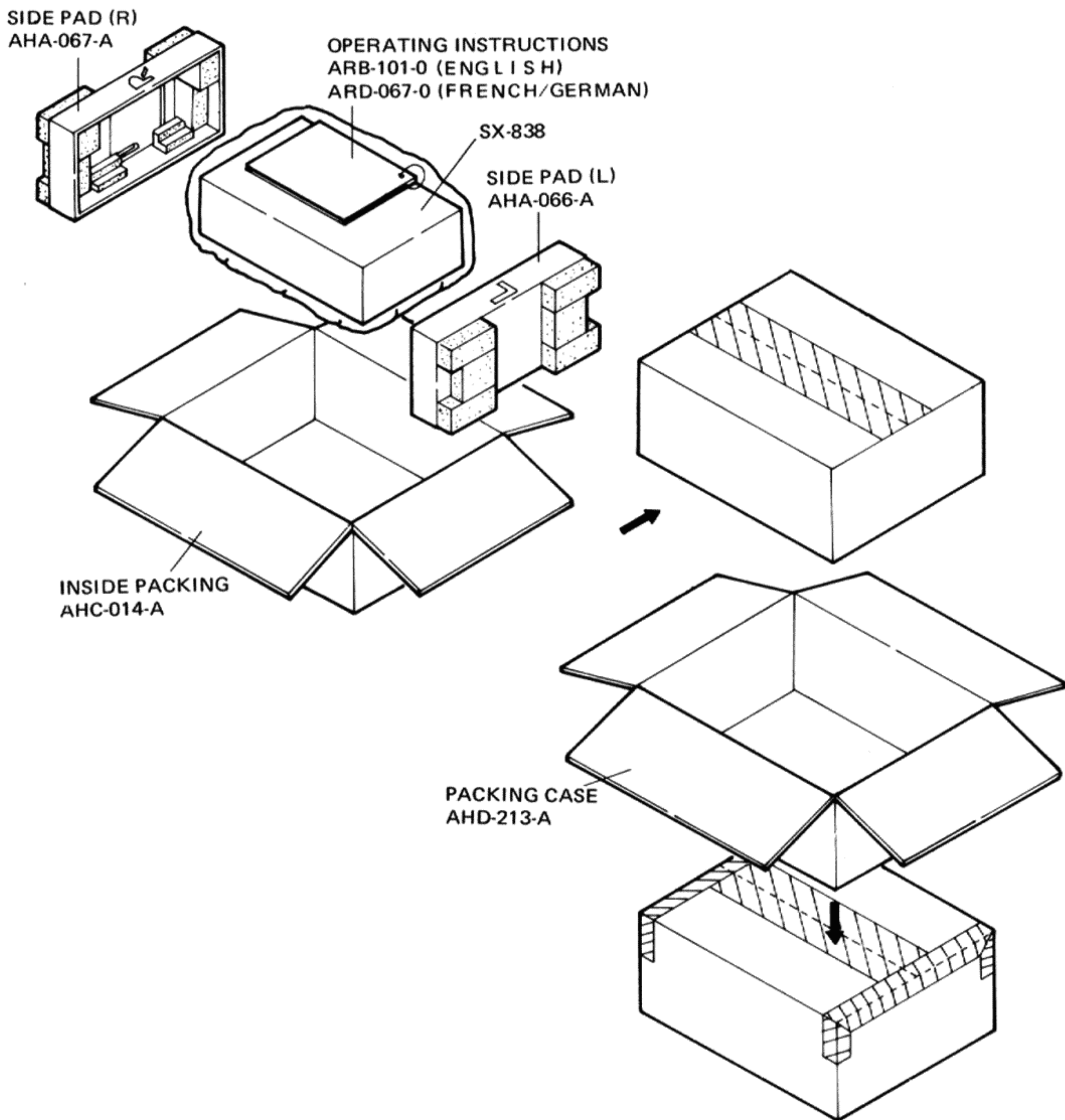

# 7. LEVEL DIAGRAM

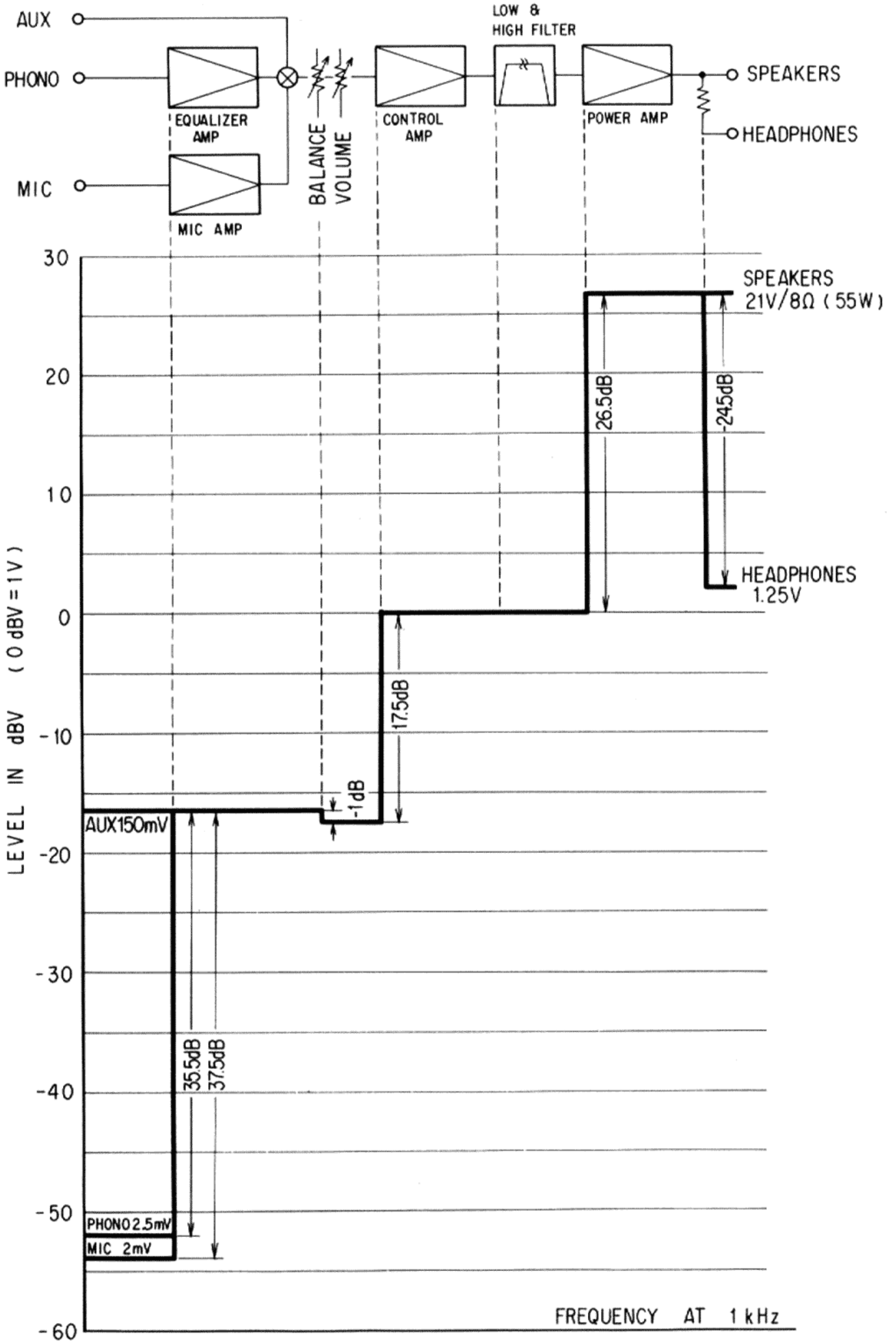

## 8. DISASSEMBLY

1. To remove the wooden cabinet, first remove the two screws holding each side, then lift the back of the wooden cabinet upward.
2. Pull off all knobs.
3. Remove the two screws in the upper edge of the front panel, and remove two nuts and washers. Then pull the panel gently forward.
4. To remove the bottom panel, first remove the ten screws holding it in place.

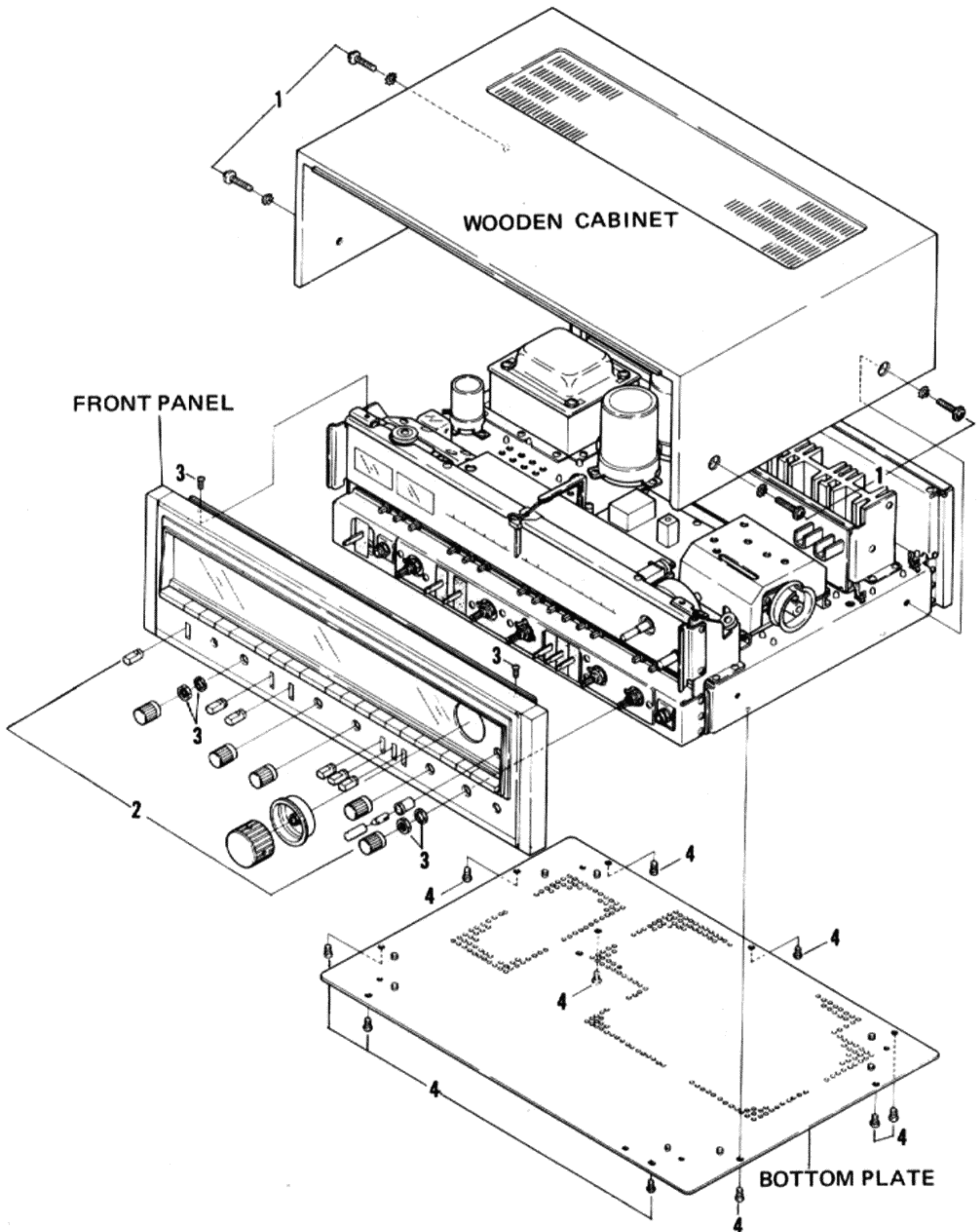

# 9. PARTS AND P.C. BOARD LOCATIONS

## Top View

FERRITE LOOPSTICK ANTENNA  
ATB-026-0

KNOB (VOLUME, BALANCE, REC  
SELECTOR, TREBLE, BASS)  
AAB-068-A

FERRITE ANTENNA HOLDER ASSEMBLY  
AXB-001-A

TUNING SHAFT ASSEMBLY  
AXA-056-0

KNOB (TUNING)  
AAA-026-0

PHONO JACK-C (6 JACKS)  
AKB-016-0

TUNING PULLEY  
ASSEMBLY  
AXA-015-A

SWITCH CIRCUIT  
ASSEMBLY  
AWS-075-0

ANTENNA TERMINAL  
BOARD  
AKA-002-0

POWER AMPLIFIER  
ASSEMBLY  
AWH-031-0

TUNER  
ASSEMBLY  
AWE-041-A

FRONT PANEL  
ASSEMBLY  
ANB-262-B

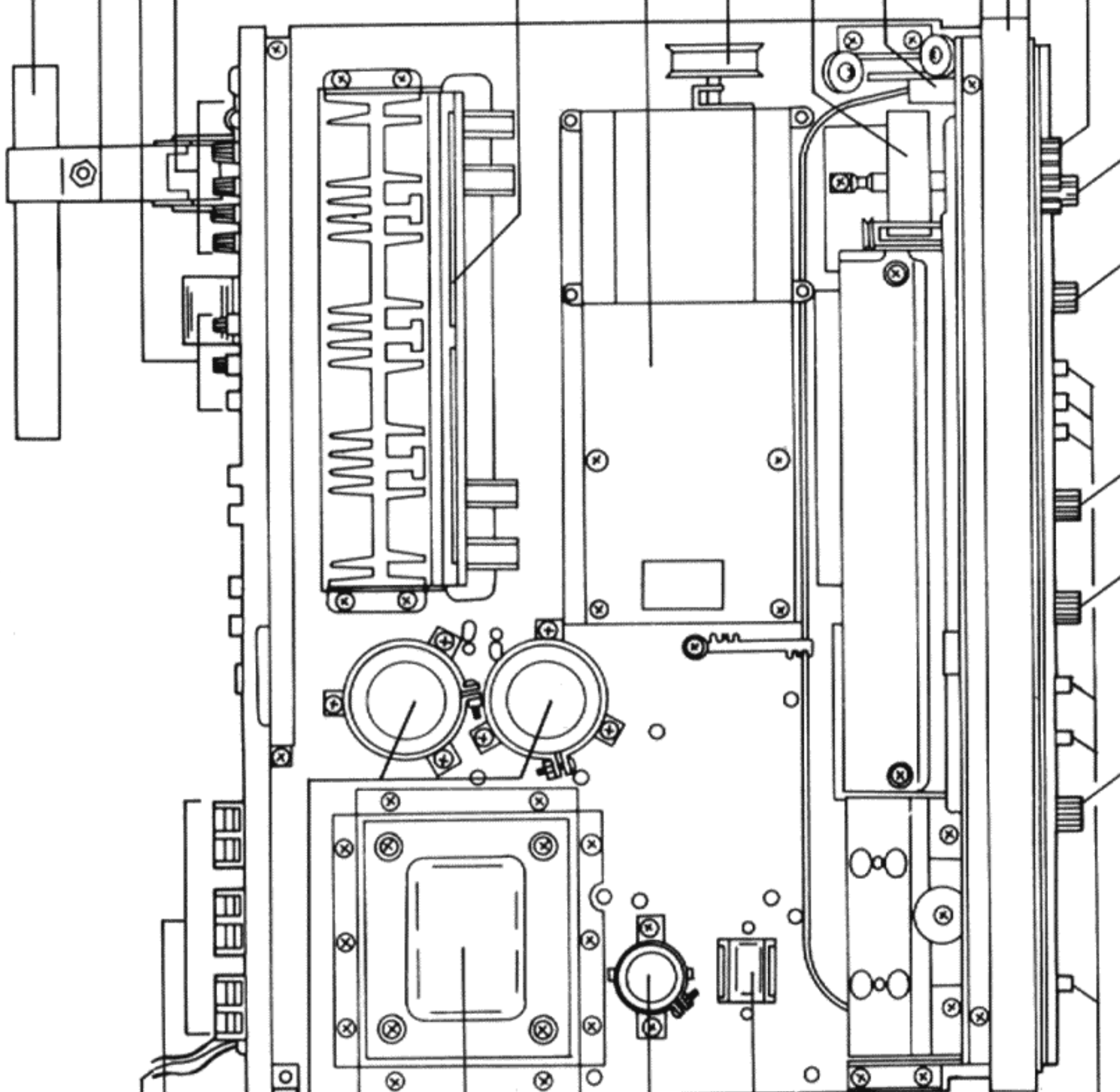

POWER  
TRANSFORMER  
ATT-168-A (KU)  
ATT-172-0 (F)

RELAY  
ASR-007-0

ELECTROLYTIC CAPACITOR  
(8,000 $\mu$ F, 50V)  
ACH-015-0

ELECTROLYTIC CAPACITOR  
(1,000 $\mu$ F, 63V)  
ACH-001-C

SPEAKER OUTPUT TERMINAL  
AKE-014-0

KNOB (POWER, TURN OVER,  
TAPE MONITOR, NR  
'ADAPTOR)  
AAD-040-0

AC POWER CORD  
ADG-005-A (KCU)  
ADG-004-0 (F)

# Bottom View

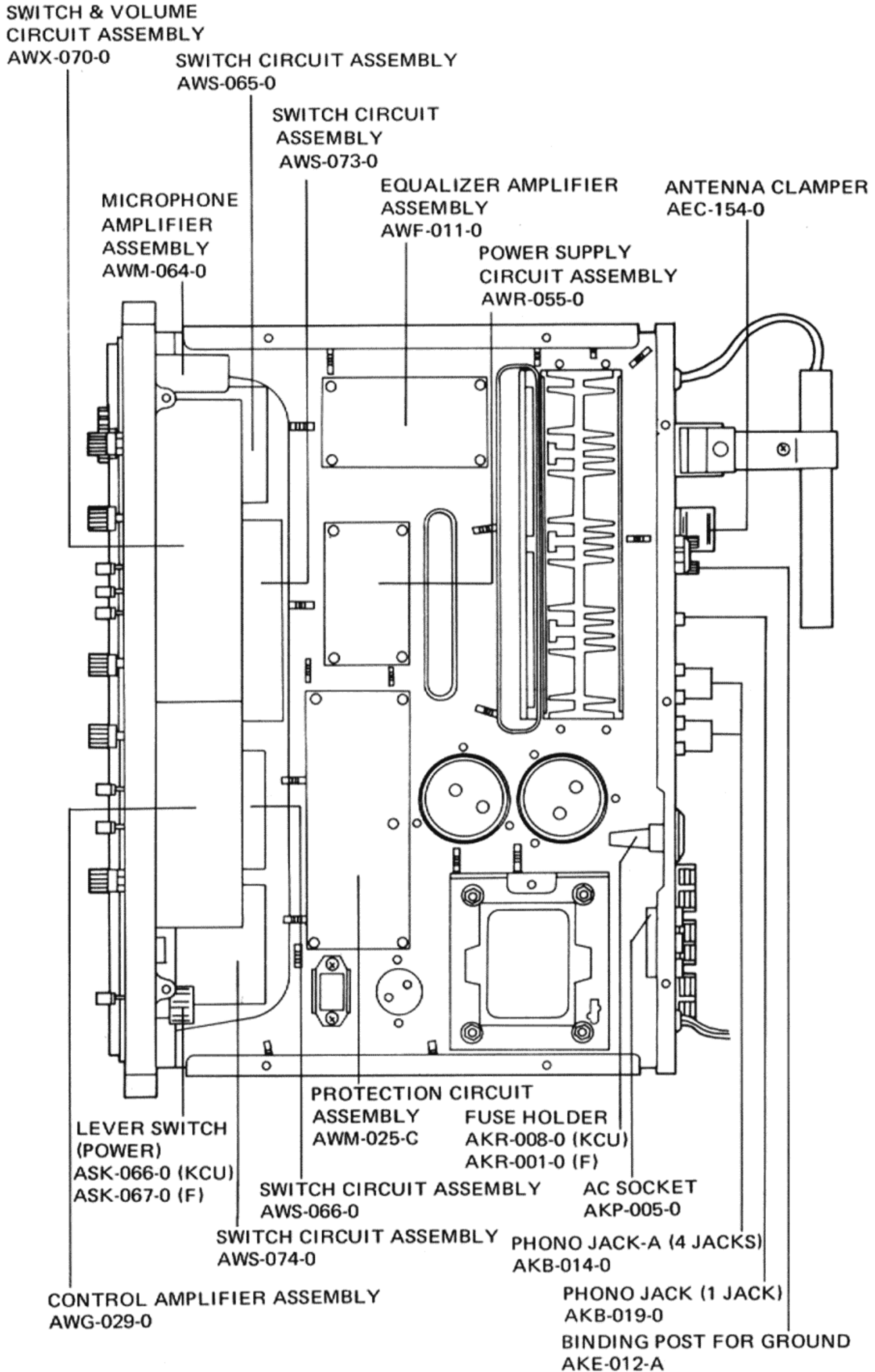

## 10. DIAL CORD STRINGING

1. Turn the tuning capacitor so that its plates protrude as much as possible.
2. The one end of the string to the spring on the TUNING pulley (attached to the tuning capacitor).
3. Lead the string around pulley A, then wind it three turns around the TUNING shaft.
4. Lead the string around pulleys B, C and D then wind it 1-1/2 turns around the TUNING pulley.
5. Now tie the other end of the string to the spring on the TUNING pulley. Turn the TUNING shaft and check for proper function. Then trim the ends of the string.
6. Turn the TUNING shaft until the plates of the variable are all the way in. Move the pointer to the left-end starting point on the dial and fasten it to the string in that position.

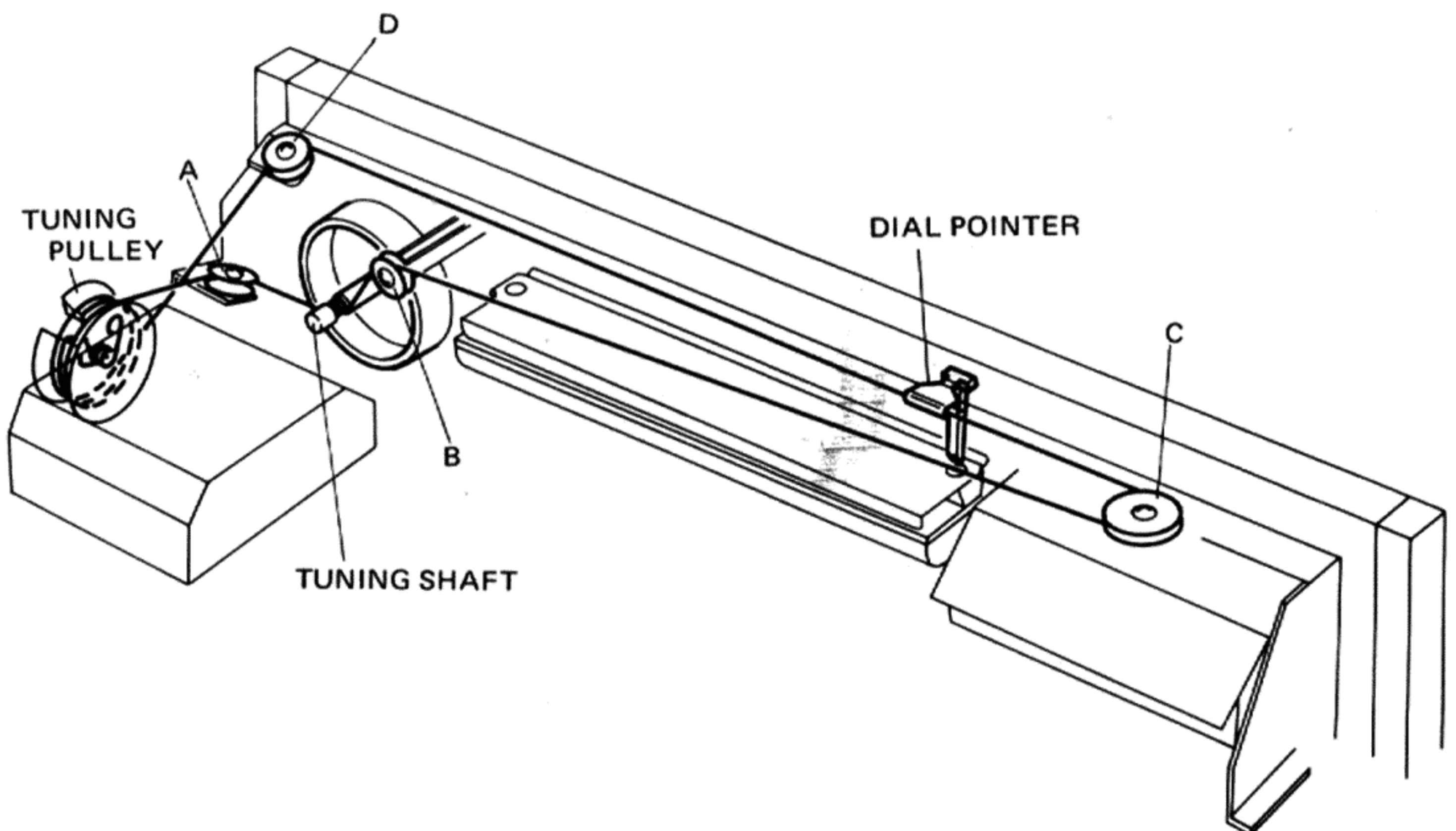

# 11. ALIGNMENT PROCEDURE

## 11.1 ENGLISH

### Aligning the FM Section

1. **SX-838 Control Settings**  
Set the controls (knob and switches) of the SX-838 as follows:  
POWER: ON  
FUNCTION: FM  
FM MUTING: OFF
2. **Connections between Test Equipment and the SX-838.**
  - The output from an FM signal generator should be connected to the 300Ω antenna terminals of the SX-838.
  - A distortion meter should be connected to the TAPE REC terminal jacks on the SX-838.
  - An AC millivolt meter should be connected to the TAPE REC terminal jacks on the SX-838 in parallel with the distortion meter.

3. Set both the FM signal generator and the SX-838 to indicate 98MHz.
4. Turn the FM signal generator output level down to minimum
5. Turn the lower core and adjust so that the TUNING meter needle is centered.
6. Increase the FM signal generator output to 60dB, modulated at 400Hz, with a deviation of ±75kHz.
7. Turn the upper core and adjust so that the distortion is at a minimum. Steps 4~above should be repeated several times in succession, until no further significant improvement is obtained.

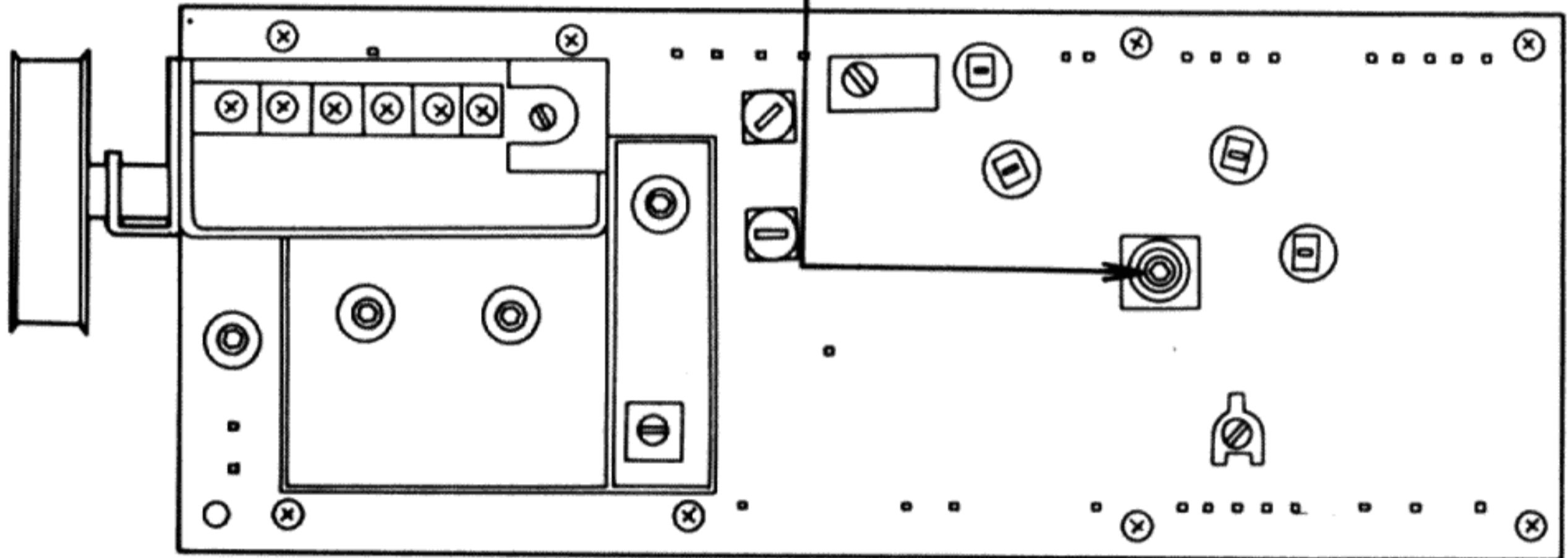

TUNER ASSEMBLY (AWE-041)

8. Set the FM signal generator output level to 10dB, modulated at 400Hz, with a frequency deviation of ±75kHz.
9. Adjust for maximum output at 90MHz.
10. Adjust for maximum output at 106MHz.
11. Adjust for maximum output at 90MHz.

12. Adjust for maximum output at 106MHz. Steps 11~12 above should be repeated several times in succession, until no further significant improvement is obtained.

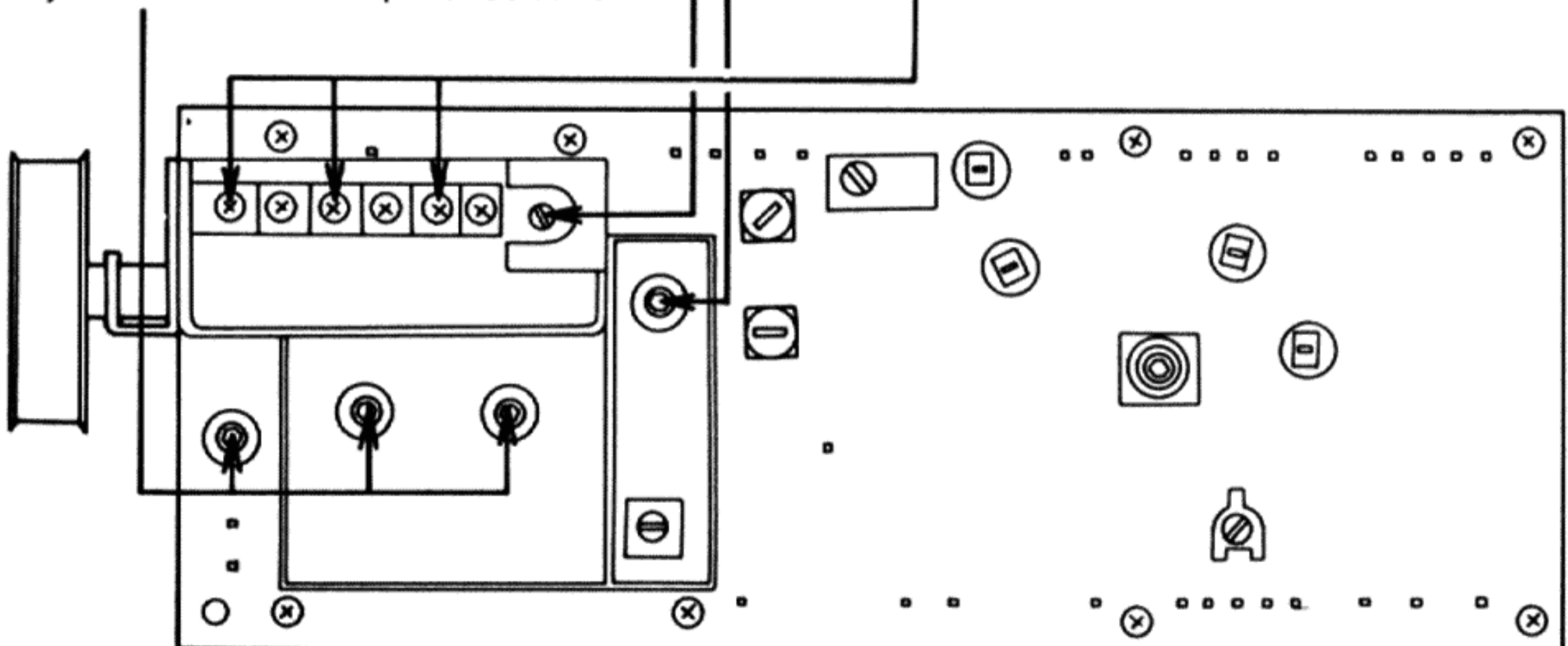

TUNER ASSEMBLY (AWE-041)

## Aligning the FM MPX Section

### NOTES:

This set of adjustments should not be carried out until the alignment of the FM section (1~12 above) has been completed: The multiplex signal generator should be connected to the external modulator terminals of the FM signal generator.

#### 1. SX-838 Control Settings

Set the controls (knob and switches) of the SX-838 as follows:

POWER: ON  
FUNCTION: FM  
FM MUTING: OFF

#### 2. Connections between the Test Equipment and the SX-838.

- The output from the FM signal generator should be connected to the 300Ω antenna terminals of the SX-838.
- The output from the MPX signal generator should be connected to the external modulator terminals of the FM signal generator.

- The oscilloscope X plates (horizontal inputs) should be connected to the PILOT OUT terminals on the MPX signal generator, and the Y plates (vertical inputs) to terminal number 18.
  - The AC millivolt meter should be connected to the TAPE REC terminals (with changeover possible from L to R channels).
3. Multiplex Signal Generator Modulation  
L + R (1kHz ): 67.5kHz deviation  
PILOT (19kHz): 7.5kHz deviation
  4. Set the FM signal generator output to minimum.
  5. Adjust for a stationary Lissajous waveform on the oscilloscope.
  6. Reset the FM signal generator to 60dB level output.  
And modulate either the L or R channel.
  7. Adjust for the maximum separation.

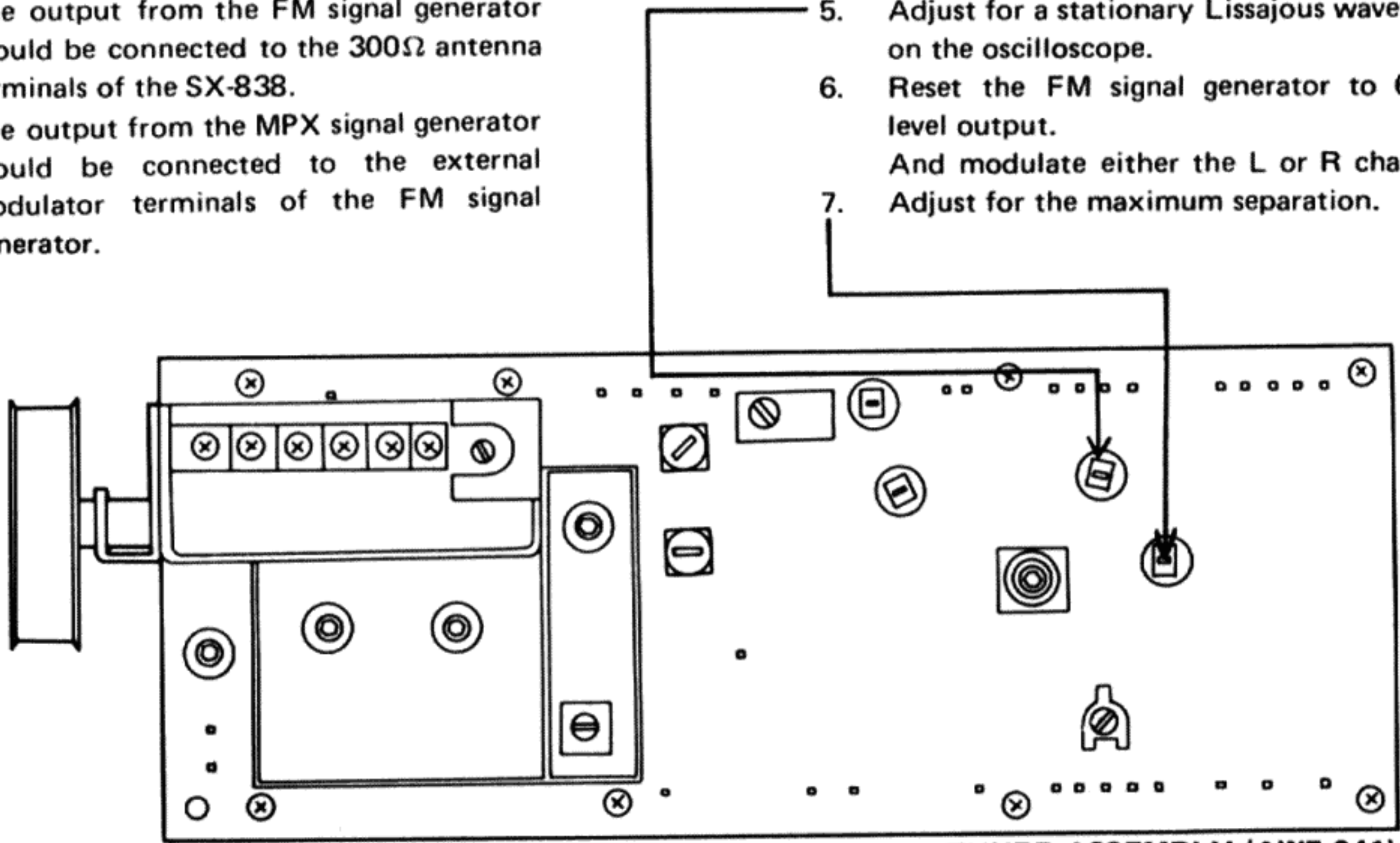

TUNER ASSEMBLY (AWE-041)

## Aligning the AM Section

1. SX-838 Control Settings  
Set the controls (knob and switch) of the SX-838 as follows:  
POWER: ON  
FUNCTION: AM
2. Connections between Test Equipment and the SX-838
  - Connect the AM signal generator to the AM antenna terminals (in series with a  $1k\Omega$  dummy resistor).
  - Connect the AC millivolt meter to the TAPE REC terminal jacks.
3. Set the AM signal generator to 30% modulation at 400Hz.
4. Set the AM signal generator output to 30dB at 600kHz.  
Adjust for maximum output (Carry out the ferrite loopstick antenna core adjustment at the same time).
5. Adjust for maximum output with the frequency set at 1,400kHz.  
Adjustments 4~5 above should be repeated several times until no further significant improvement is obtained.
6. Connect the AM signal generator directly to the AM ANT (antenna) terminals.

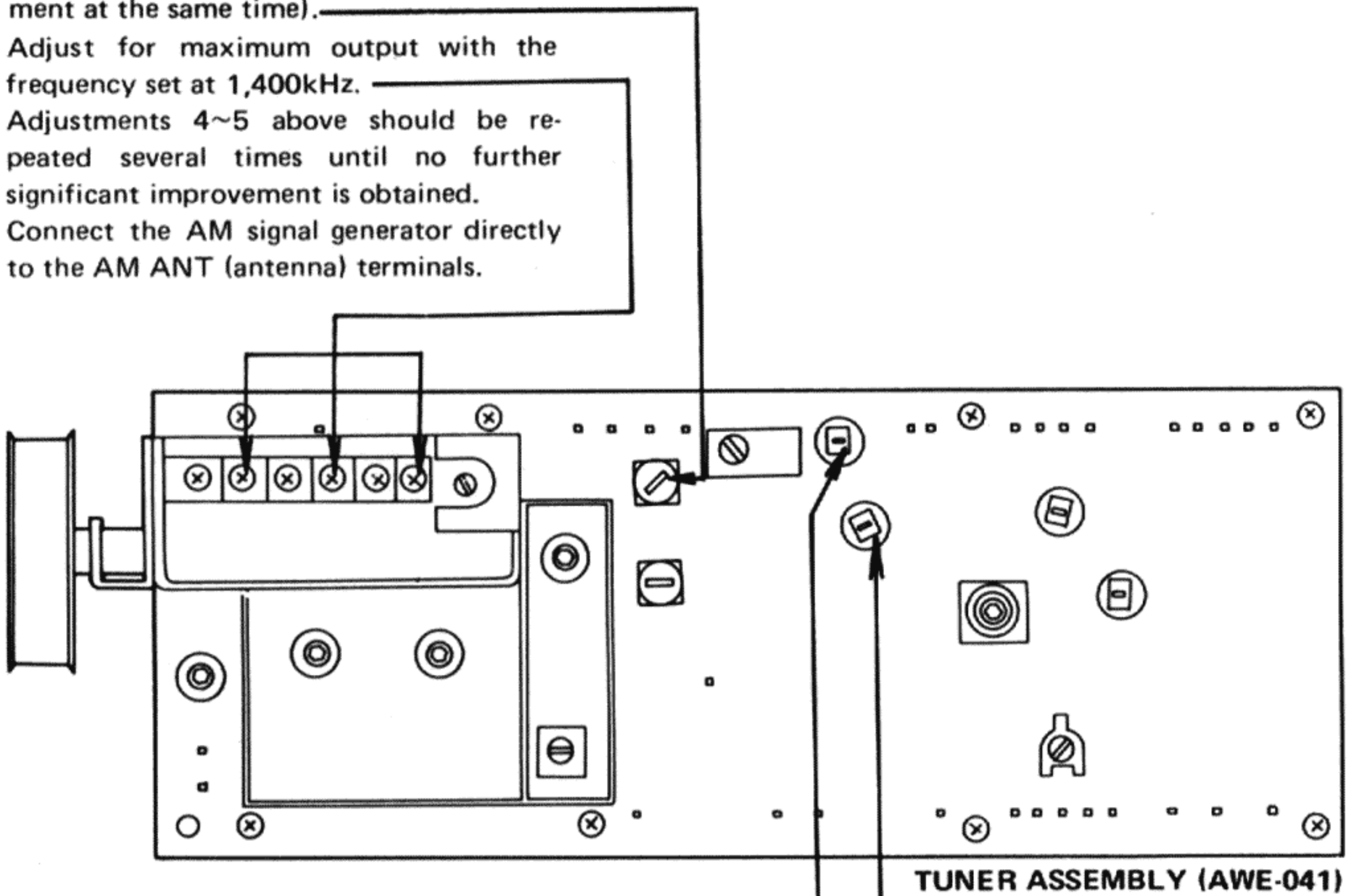

7. With a frequency of 1,400kHz and an AM signal generator output of 36dB, adjust for a low frequency output of 70mV.
8. With an AM signal generator output of 80dB, adjust for a low frequency output of 310mV.

## Aligning the Power Amplifier Section

1. Nothing should be connected to the input jacks of the SX-838, and an  $8\Omega$  dummy resistor should be connected across the speaker terminals.
2. A DC millivolt meter should be connected across between terminal number 5 and earth (20 and earth; for right channel)
3. Adjustment should be made to bring the voltage to zero.
4. The DC voltmeter should be connected between terminals number 3 and 4 (22 and 23; for right channel)
5. Adjustment should be made to bring the voltage to 30mV.

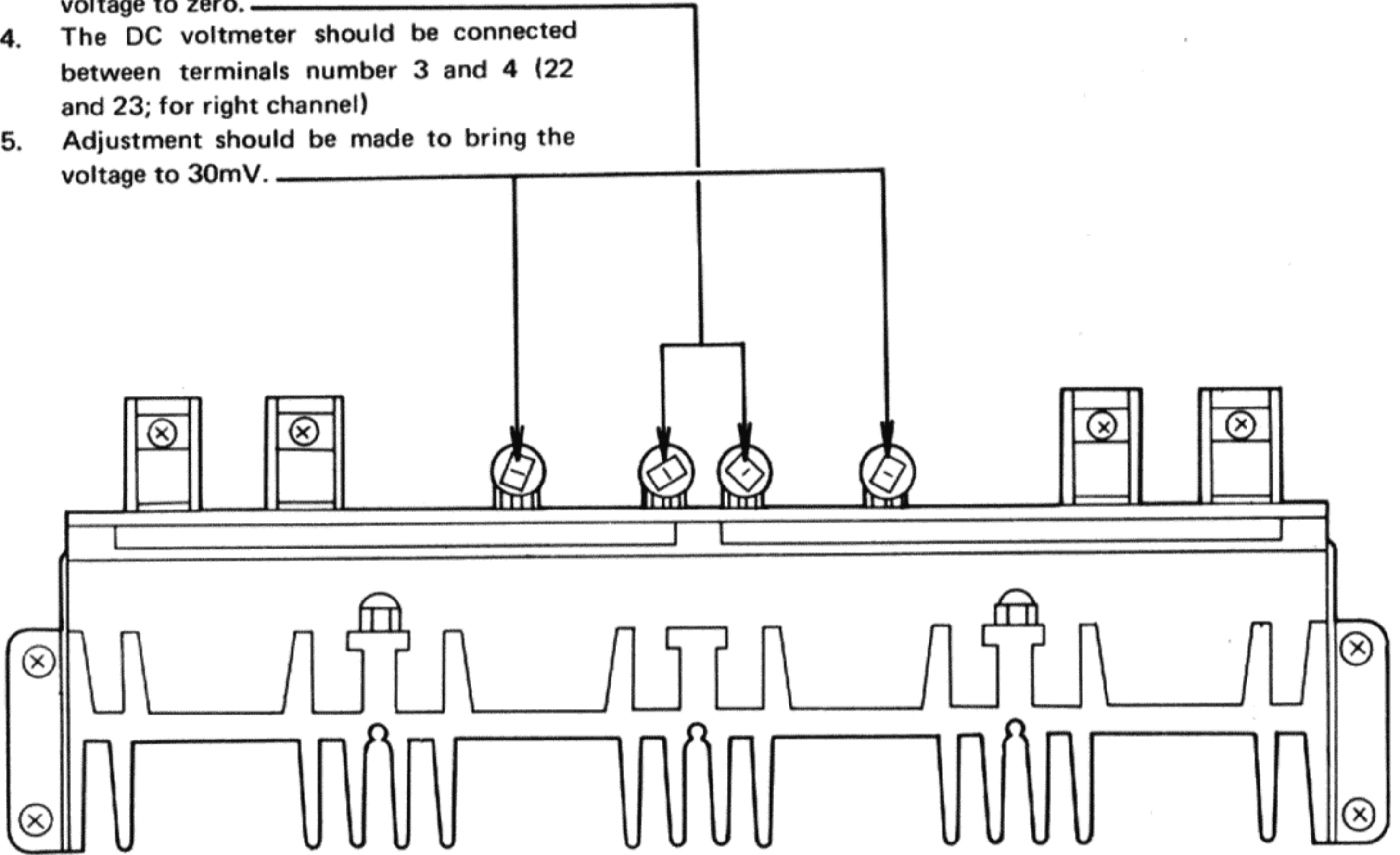

POWER AMPLIFIER ASSEMBLY (AWH-031)

## 11.2 German

### ABGLEICHVERFAHREN

#### Abgleichen Des FM-Teils

1. Regeleinstellungen am SX-838  
Die Steuerelemente (Knöpfe und Schalter) des SX-838 sind wie folgt einzustellen:  
POWER (Stromzuführung): ON (Ein)  
FUNCTION (Funktion): FM  
FM MUTING (FM-Dämpfung): OFF (Aus)
2. Schaltungen zwischen Prüfsatz und dem SX-838.
  - Der Ausgang von einem FM-Prüfsender ist mit den 300-Ohm-Antennenanschlüssen des SX-838 zu verbinden.
  - Ein Klirrfaktormeßgerät ist mit den Anschlußbuchsen des SX-838 TAPE REC (Band-aufnahme) zu verbinden.
  - Ein Millivolt-Wechselspannungsmesser ist parallel zum Klirrfaktormeßgerät mit den Anschlußbuchsen TAPE REC (Band-aufnahme) des SX-838 zu verbinden.

3. Der FM-Prüfsender und der SX-838 sind beide auf eine Anzeige von 98 MHz einzustellen.
4. Der Ausgangspegel des FM-Prüfsenders ist auf minimale Einstellung herunterzudrehen.
5. Der untere Kern ist zu drehen und so einzustellen, daß die Nadel des Abstimm-Meters zentriert ist.
6. Der Ausgang des FM-Prüfsenders ist moduliert bei 400 Hz bei einer Abweichung von  $\pm 75$  kHz auf 60 dB zu erhöhen.
7. Der obere Kern ist zu drehen und so einzustellen, daß die Verzerrung minimal wird. Obige Schritte 4 – 7 sollen mehrmals nacheinander wiederholt werden, bis keine merkliche Verbesserung erzielt wird.

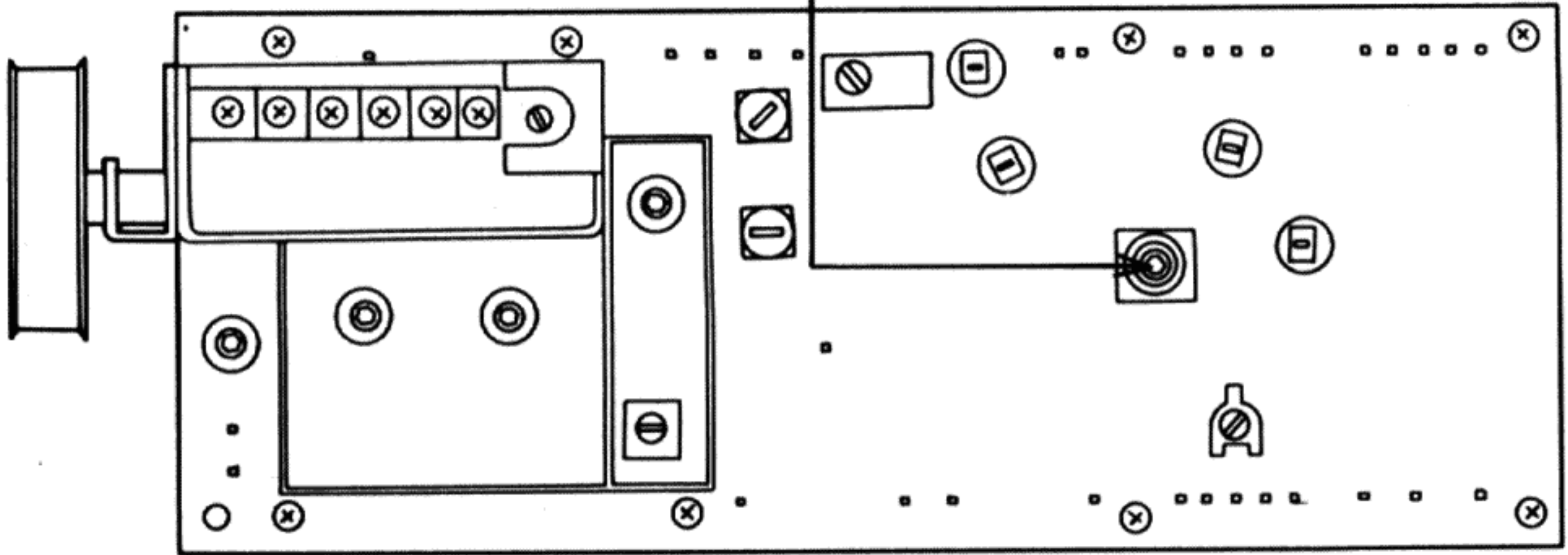

8. Der Ausgangspegel des FM-Prüfsenders ist, moduliert bei 400 Hz bei einer Frequenzabweichung von  $\pm 75$  kHz, auf 10 dB einzustellen.
9. Es ist auf maximalen Ausgang bei 87,4 MHz einzustellen.
10. Es ist auf maximalen Ausgang bei 106 MHz einzustellen.
11. Es ist auf maximalen Ausgang bei 90 MHz einzustellen.

12. Es ist auf maximalen Ausgang bei 106 MHz einzustellen. Obige Schritte 11 – 12 sind mehrfach nacheinander zu wiederholen, bis keine weitere merkliche Verbesserung erzielt wird.

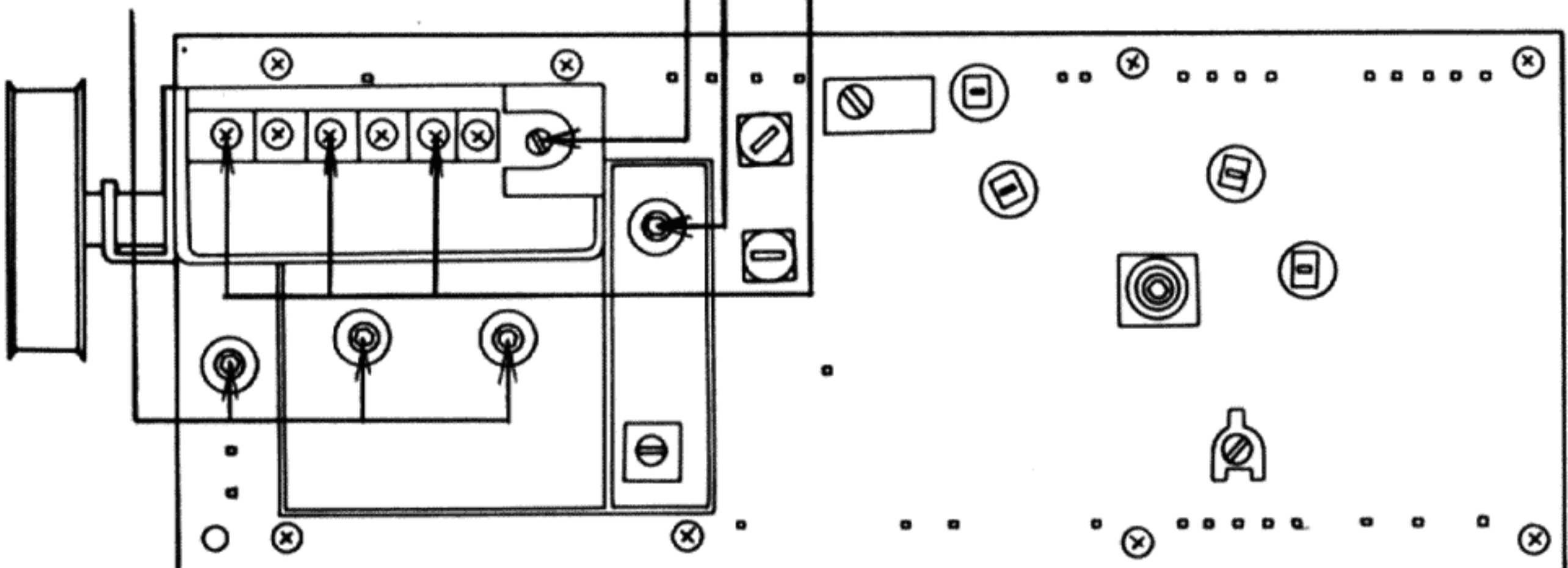

## Abgleichen Des FM-MPX-Teils

Zur Beachtung: Die folgenden Einstellschritte sollten nicht vor Beendigung des Abgleichs des FM-Teils (siehe oben 1 – 12) durchgeführt werden.

Der Multiplex-Prüfsender ist mit den Außenmodulatoranschlüssen des FM-Prüfsenders zu verbinden.

1. Regeleinstellungen am SX-838  
Die Steuerelemente (Knöpfe und Schalter) des SX-838 sind wie folgt einzustellen:  
POWER (Stromzuführung): ON (Ein)  
FUNCTION (Funktion): FM (UKW)  
FM MUTING (FM-Dämpfung): OFF (Aus)
2. Schaltungen zwischen Prüfsatz und dem SX-838.  
- Der Ausgang vom FM-Prüfsender ist mit den 300- $\Omega$ -Antennenanschlüssen des SX-838 zu verbinden.  
- Der Ausgang vom MPX-Prüfsender ist an die Außenmodulatoranschlüsse des FM-Prüfsenders anzuschließen.

- Die x-Anoden des Oszilloskops sind mit den Anschlüssen PILOT OUT am MPX-Prüfsender und die y-Anoden mit dem Anschluß 18 zu verbinden.

- Der Millivolt-Wechselspannungsmesser ist mit den TAPE REC (Band/Aufnahme)-Anschlüssen (mit Umschaltmöglichkeit von den Kanälen LH auf RH) zu verbinden.

3. Modulation des Multiplex-Prüfsenders  
L+R (1 kHz): Abweichung von 67,5kHz  
PILOT (19 kHz): Abweichung von 7,5kHz
4. Der Ausgang des FM-Prüfsenders ist auf minimales Niveau einzustellen.
5. Am Oszilloskop ist eine Einstellung auf eine stehende Wellenform der Lissajousschen Figur durchzuführen.
6. Der FM-Prüfsender ist auf einen Pegelausgang von 60 dB zurückzustellen und entweder der LH- oder der RH- Kanal zu modulieren.
7. Es ist auf maximale Trennung einzustellen.

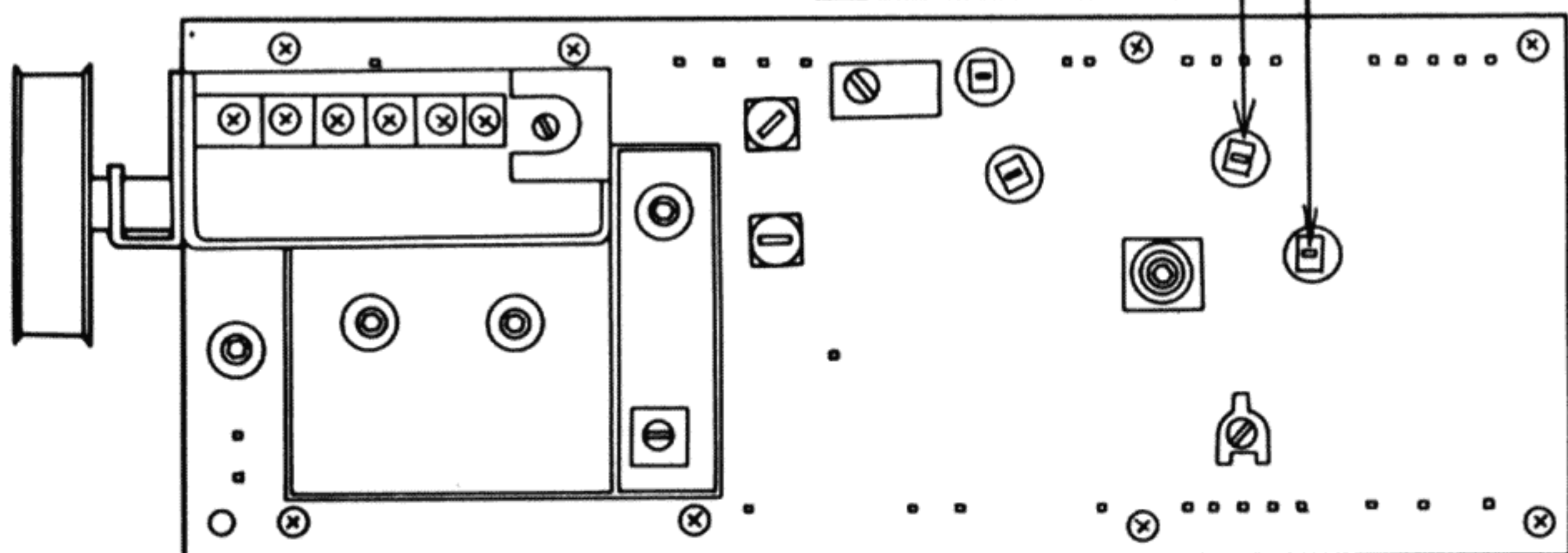

## Abgleichen Des AM-Teils

1. Regeleinstellungen am SX-838  
Die Steuerelemente (Knöpfe und Schalter) des SX-838 sind wie folgt einzustellen:  
POWER (Stromzuführung): ON (Ein)  
FUNCTION (Funktion): AM
2. Schaltungen zwischen Prüfsatz und dem SX-838.  
- Der AM-Prüfsender ist mit den AM-Antennenanschlüssen (in Reihenschaltung mit einem künstlichen Widerstand von  $1\text{ k}\Omega$ ) zu verbinden.  
- Der Millivolt-Wechselspannungsmesser ist mit den Anschlußbuchsen TAPE REC (Band-aufnahme) zu verbinden.
3. Der AM-Prüfsender ist auf eine Modulation von 30% bei 400 Hz einzustellen.
4. Der Ausgang des AM-Prüfsenders ist auf 30 dB bei 600 kHz einzustellen. Es ist der maximale Ausgang bei gleichzeitiger Einstellung des Ferritstabantennenkerns einzustellen.
5. Es ist der maximale Ausgang bei einer Frequenzeinstellung auf 1400 kHz einzustellen. Obige Einstellungen 4 – 5 sind mehrfach zu wiederholen, bis keine weitere merkliche Verbesserung erzielt wird.
6. Der AM-Prüfsender ist direkt mit den Anschlüssen AM ANT (Antenne) zu verbinden.

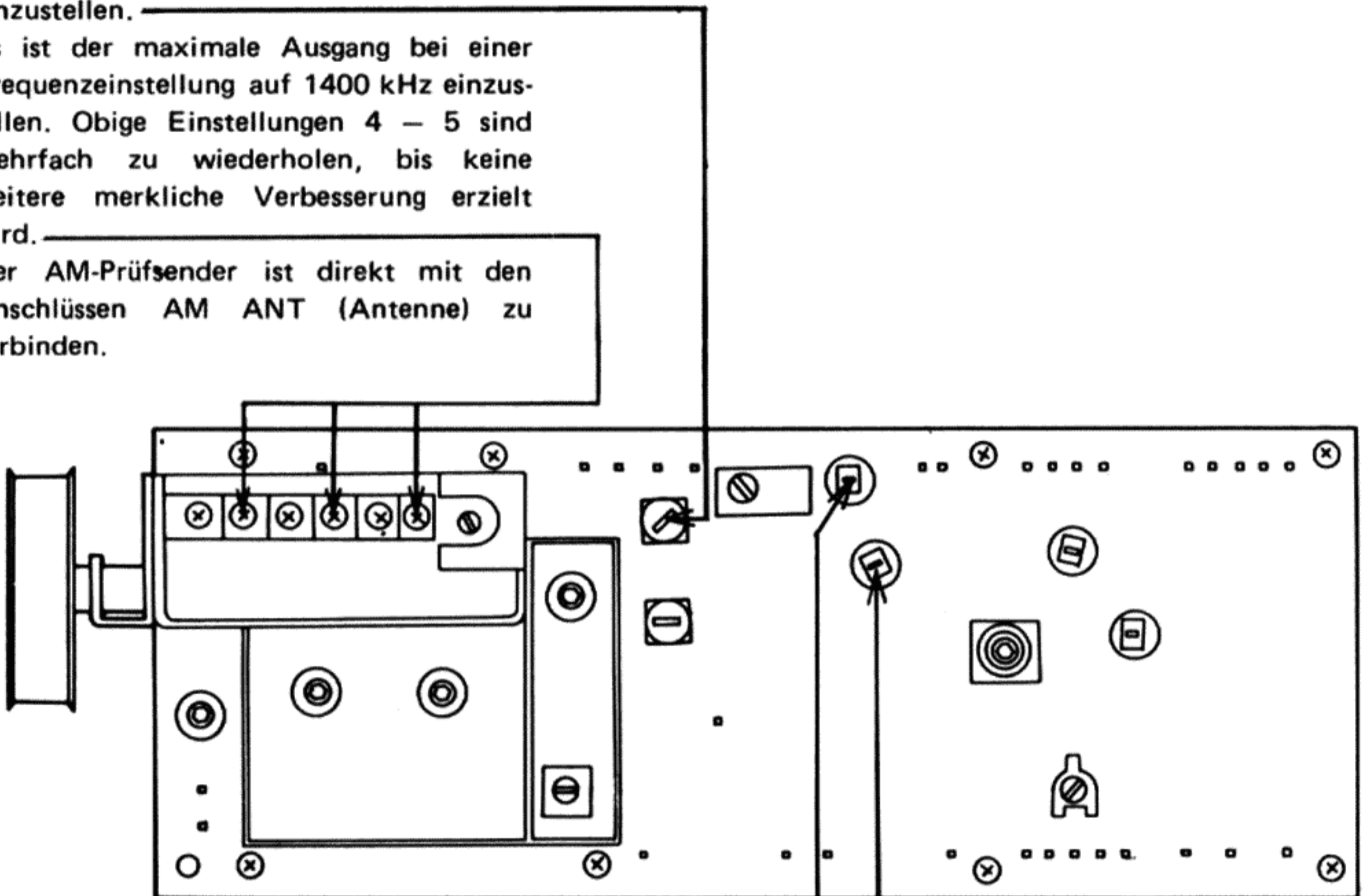

7. Bei einer Frequenz von 1400 kHz und einem Ausgang des AM-Prüfsenders von 36 dB ist auf einen Niederfrequenzausgang von -21 dBs (70 mV) einzustellen.
8. Bei einem Ausgang des AM-Prüfsenders von 80 dB ist eine Einstellung auf einen Niederfrequenzausgang von -12 dBs (310 mV) durchzuführen.

## Abgleichen Der Endverstärkerstufe

1. Es ist nichts an die Eingangsbuchsen des SX-838 anzuschließen; ein künstlicher Widerstand von  $8\ \Omega$  ist über die Lautsprecheranschlüsse anzulegen.
2. Ein Millivolt-Gleichspannungsmesser ist zwischen Anschluß 19 und Erde zu schalten.
3. Eine Einstellung soll so erfolgen, daß die Spannung auf Null gebracht wird.
4. Der Gleichspannungsmesser ist zwischen die Anschlüsse 14 und 16 zu schalten.
5. Eine Einstellung soll so erfolgen, daß die Spannung auf 50 mV gebracht wird.

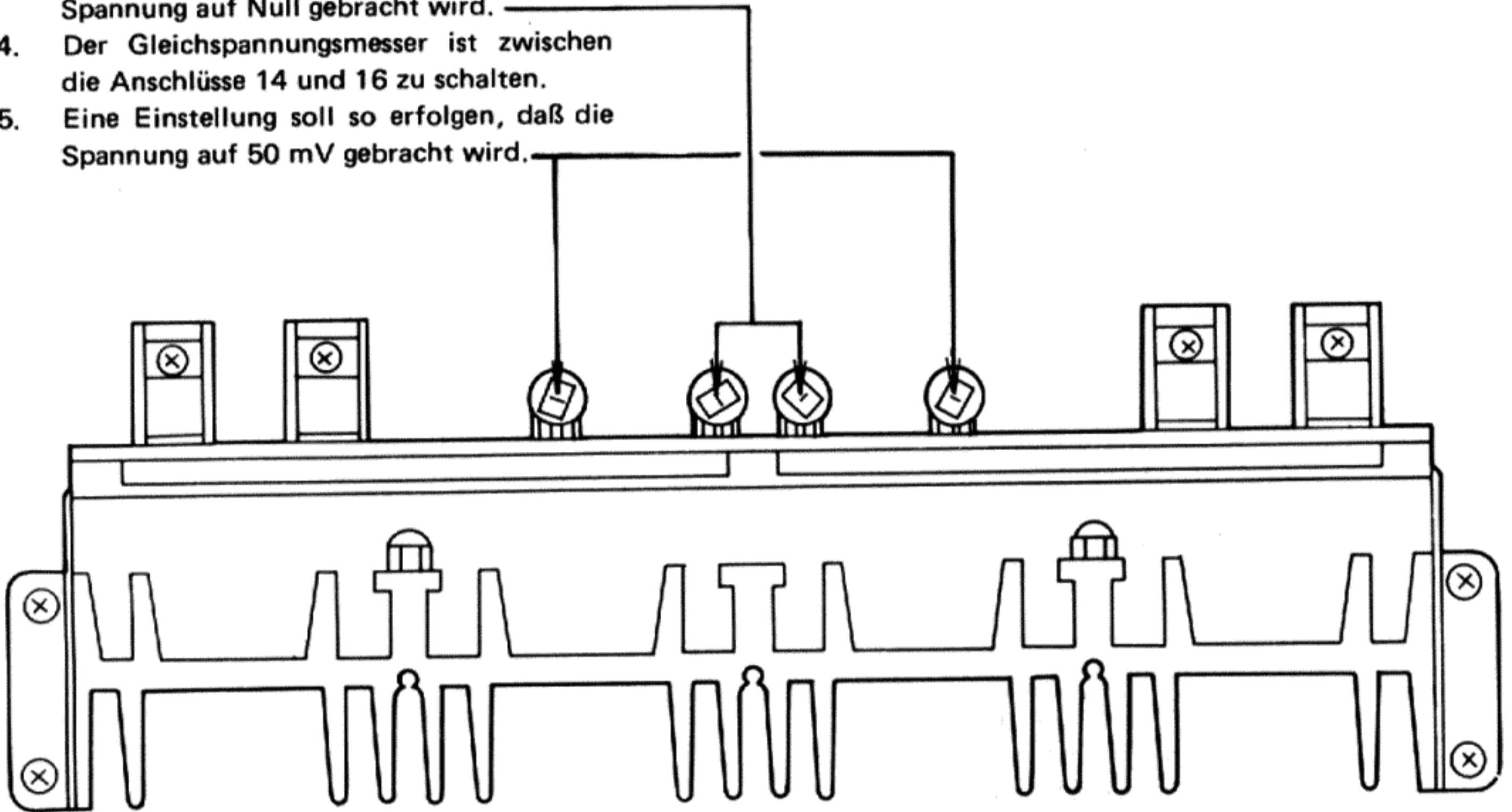

# 12. EXPLODED VIEW AND PARTS LIST

**NOTE:**

Parts number is subject to change for the purpose of improvement with notice of a service bulletin.

Service bulletin will be furnished whenever necessary and you are requested to amend parts number in this manual according to the instructions.

NOTICE: Any parts asterisked (\*) are subject to being not supplied.

## Parts List of Exploded View-1

Key No.	Description	Part No.	
1	Power transformer	ATT-168-A	KCU F GN
	Power transformer	ATT-172-0	
	Power transformer	ATT-181-0	
2*	Sub-chassis	ANF-235-A	
3	Electrolytic capacitor 1,000 $\mu$ F 63V	ACH-001-C	
4	Electrolytic capacitor 8,000 $\mu$ F 50V	ACH-015-0	
5*	Chassis	ANA-066-E	
6*	Wire supporter	AEC-084-C	
7	Foot	AEC-027-0	
8*	Bottom plate	ANE-057-B	
9*	Wire clip B	AEC-005-0	
10	Relay	ASR-007-0	
11*	Wire clip A	AEC-004-0	
12	Ground terminal strip	K13-047-0	
13*	P.C. board holder	AEB-019-0	
14	Protection circuit assembly	AWM-025-C	
15	Power supply circuit assembly	AWR-055-A	KCU, F GN
	Power supply circuit assembly	AWR-064-0	
16	Equalizer amplifier assembly	AWF-011-0	
17*	Shield plate	ANF-250-0	
18*	Wire clip	AEC-064-0	
19	Power amplifier assembly	AWH-031-A	
20	Ground terminal strip (2P)	K13-048-0	
21*	Wire clip C	AEC-007-0	
22*	Shield cover	ANF-240-A	
23	Tuner assembly	AWE-041-A	
24	Tuning pulley assembly	AXA-015-A	
25*	P.C. board-held metal (A)	ANF-237-A	
26*	P.C. board-held metal (B)	ANF-238-A	
27	Wooden cabinet	AMM-035-B	
28	Screw M4X26	ABA-011-A	
29	Washer	B21-011-0	

Exploded View-1

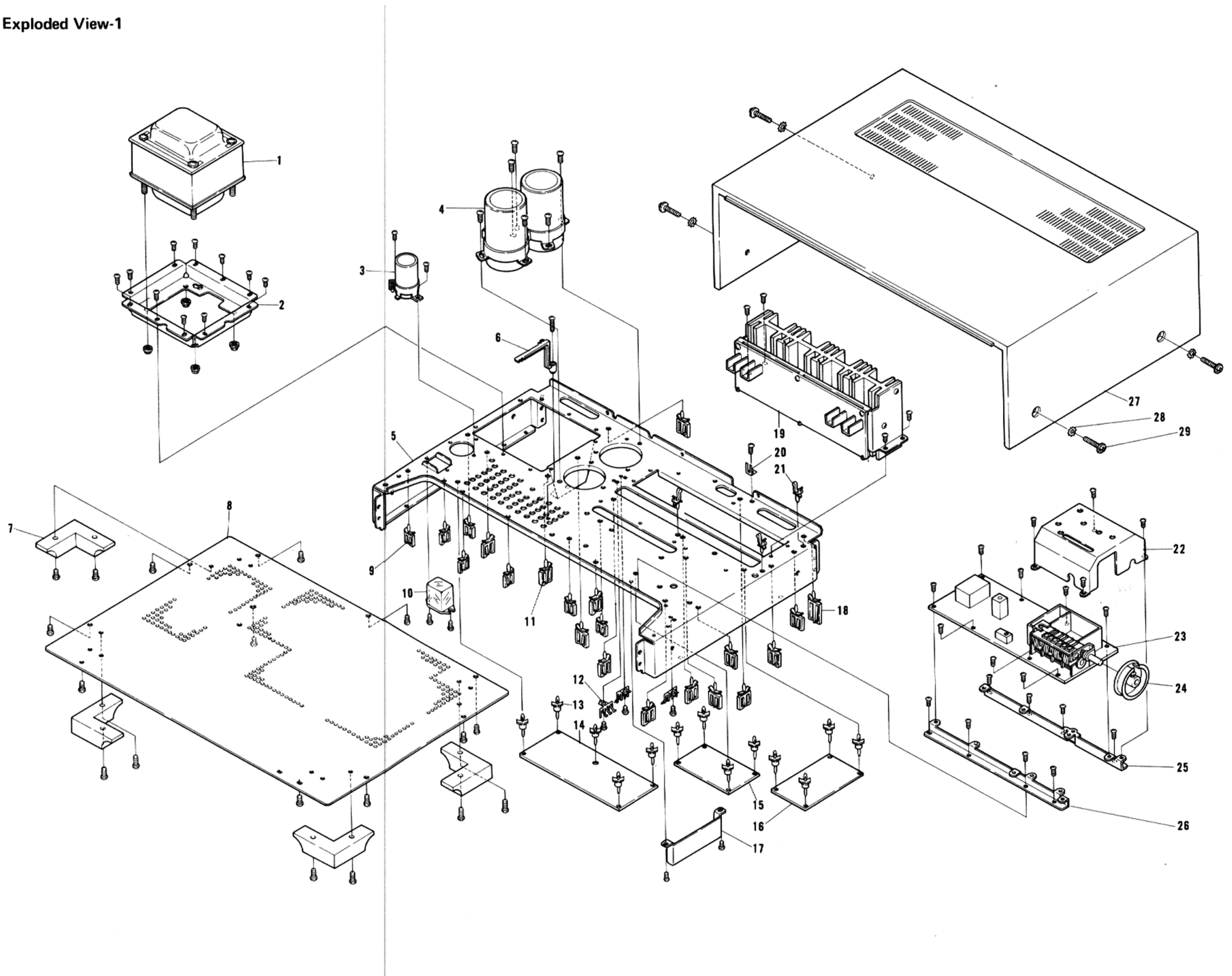

## Parts List of Exploded View-2

Key No.	Description	Part No.	
1	Dial scale	AAG-075-A	
2*	Dial scale-held metal	ANF-243-A	
3	Dial pointer assembly	AAF-031-A	
4	Meter (Signal & Tuning)	AAW-029-0	
5*	Lamp box	ANH-211-B	
6*	Lamp holder	ANG-097-0	
7	Pilot lamp socket	AKK-002-0	
8	Pilot lamp 8V, 0.3A (meter)	AEL-015-0	
9*	P.C. board cover	ANG-100-0	
10	Lamp board assembly	AWX-069-0	
11*	Lamp box	ANH-210-A	
12	Rubber bracket	AEB-031-A	
13	Pilot lamp 6V, 30mA (Stereo indicator)	AEL-014-0	
14	Front panel assembly	ANB-262-B	
15	Knob (Power, Turn over, Tape monitor, NR adaptor)	AAD-040-0	
16	Knob (Bass)	AAB-068-A	
17	Knob (Treble, Volume, Balance, Rec selector)	AAB-068-A	
18	Knob (Tuning)	AAA-026-0	
19	Ornamental ring	AAC-034-0	
20	Knob (FM muting)	AAD-082-A	
21	Coupler (Knob-to-switch)	AAE-007-0	
22	Spacer	AEC-152-A	
23	Knob (SPKR A, B, C)	AAD-064-A	
24	Knob (Low cut, High cut, -20dB)	AAD-065-A	
25	Knob (Function)	AAD-066-A	
26	Knob (Mode, Loudness)	AAD-067-A	
27	Lever switch (Power)	ASK-066-0	KCU
	Lever switch (Power)	ASK-067-0	F
	Lever switch (Power)	ASK-068-0	GN
28	Phone jack (Headphone)	K72-026-0	
29	Shading plate	AED-018-0	
30	Nut (insulator)	B71-031-0	
31*	Sub-chassis	AND-074-B	
32*	Shield cover	ANF-234-0	
33	Control amplifier assembly	AWG-029-0	
34	Switch & volume circuit assembly	AWX-070-0	
35	Microphone amplifier assembly	AWM-064-0	
36*	Shading metal	ANF-249-0	
37*	Pulley shaft	M49-025-E	
38*	Pulley	AEC-153-0	
39	Rubber bracket	AEB-057-A	
40	Pilot lamp 8V, 50mA (program indicator)	AEL-022-0	

Key No.	Description	Part No.	
41*	Lamp holder	ANG-103-0	
42*	Sub-panel	AND-073-B	
43*	Pulley-held metal	ANG-102-A	
44*	Pulley	AEC-101-0	
45*	Pulley shaft	M49-025-E	
46	Rubber bracket	AEB-057-A	
47	Pilot lamp 8V,50mA (program indicator)	AEL-023-0	
48*	Lamp holder	ANG-104-0	
49*	Pulley	AEC-101-0	
50*	Pulley shaft	M49-025-E	
51*	Shading metal	ANF-249-0	
52	Switch circuit assembly (FM muting)	AWS-075-0	
53	Tuning shaft assembly	AXA-056-0	
54	Switch circuit assembly (speakers)	AWS-074-0	
55	Switch circuit assembly (filter, AF muting)	AWS-066-0	
56	Switch circuit assembly(function)	AWS-073-0	
57	Switch circuit assembly(mode, loudness)	AWS-065-0	
58*	Shield cover	ANF-233-0	
59	Speaker output terminal	AKE-014-0	
60	AC socket	AKP-005-0	KCU, F
61	5P connector assembly	AWX-062-0	
62	Fuse holder	AKR-008-0	KCU
	Fuse holder	AKR-001-0	F
63	Phono jack-A (4 jacks)	AKB-014-0	
64	Phono jack-C (6 jacks)	AKB-016-0	
65	Phono jack (1 jack )	AKB-019-0	
66	Antenna terminal board	AKA-002-0	
67*	Rear panel	ANC-107-D	KCU
	Rear panel	ANC-112-B	F
	Rear Panel	ANC-114-0	GN
68	AC power cord	ADG-005-0	KCU
	AC power cord	ADG-004-0	F
69	AC cord grommet	AEC-079-0	KCU, F
	Connector (AC power)	AKP-008-0	GN
70*	Model name plate	AAL-186-0	KCU
	Model name plate	AAL-202-0	F
	Model name plate	AAL-188-0	GN
71	Binding post for ground	AKE-012-A	
72	Ferrite antenna holder assembly	AXB-001-A	
73	Ferrite loopstick antenna	ATB-026-0	
74	Antenna clamber	AEC-154-0	
75	AC cord grommet	AEC-079-0	

Exploded View-2

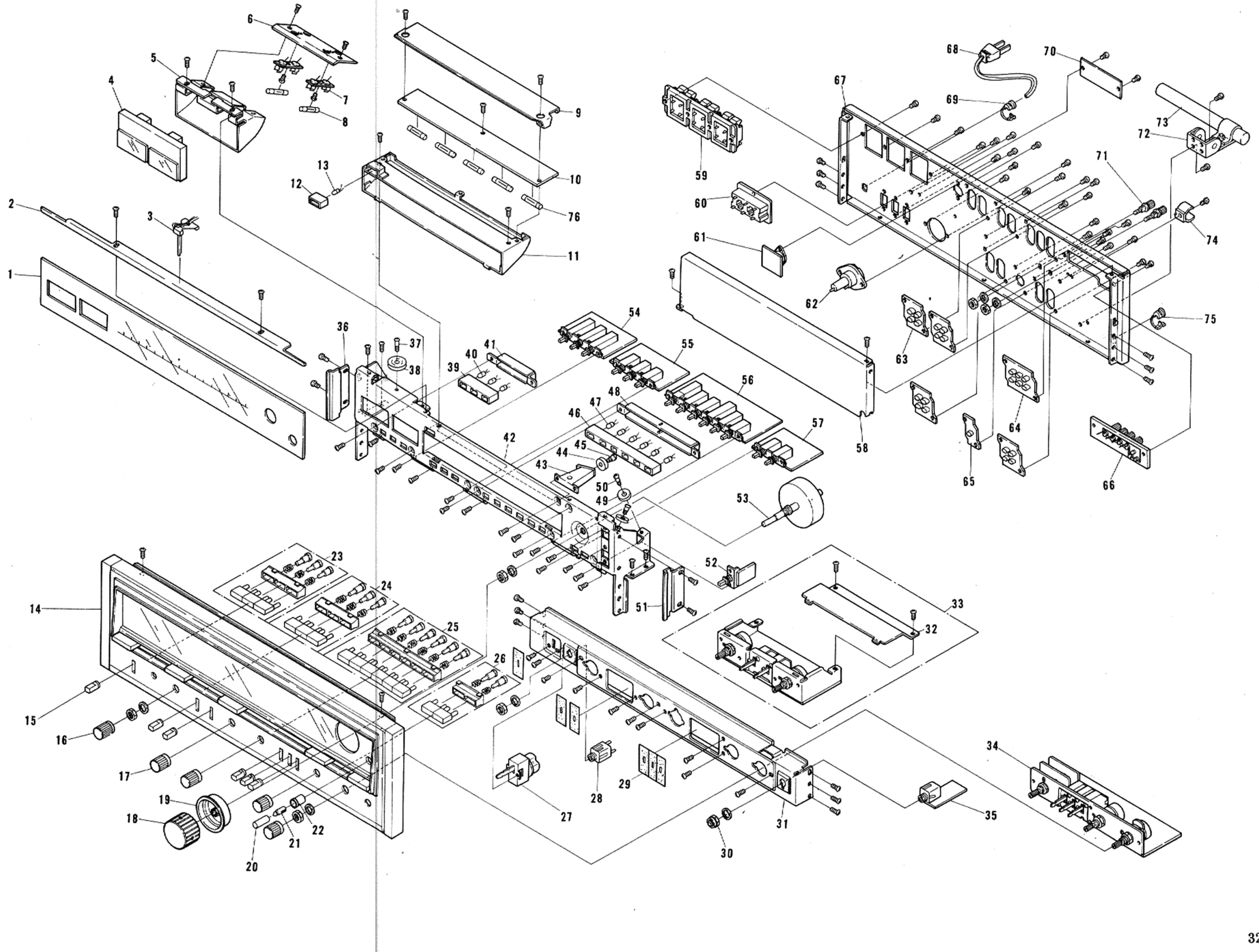

# 13. SCHEMATIC DIAGRAMS, P.C. BOARD PATTERNS AND PARTS LIST

## 13. 1 CIRCUIT CONNECTION DIAGRAM AND MISCELLANEOUS PARTS



- CAPACITORS: IN  $\mu$ F UNLESS OTHERWISE NOTED p: pF
- RESISTORS: IN  $\Omega$ ,  $\frac{1}{4}$ W UNLESS OTHERWISE NOTED k: k $\Omega$ , M: M $\Omega$

## Miscellaneous Parts List

### CAPACITORS

Symbol	Description	Part No.	
C1	Electrolytic 8,000 50V	ACH-015-0	KCU F
C2	Electrolytic 8,000 50V	ACH-015-0	
C3	Electrolytic 1,000 63V	ACH-001-C	
C4	Ceramic 0.01 50V	CKDYF 103Z 50	
C6	Ceramic 0.01 250V	ACG-001-0	
C7	Ceramic 0.01 250V	ACG-003-0	
	Ceramic 0.01 250V	ACG-001-0	
C8	Mylar 0.0007 50V	CQMA 472J 50	
C9	Mylar 0.0047 50V	CQMA 472J 50	

### RESISTOR

Symbol	Description	Part No.	
R1	Carbon film 2.2M $\frac{1}{2}$ W	RD $\frac{1}{2}$ PS 225J	KCU

### SWITCHES

Symbol	Description	Part No.	
S1	Lever switch (Power)	ASK-066-0	KCU
	Lever switch (Power)	ASK-067-0	F
S2	Relay	ASR-007-0	KCU
S3	Fuse holder	AKR-008-0	KCU
S4	Slide switch	ASH-008-0	F

### OTHERS

Symbol	Description	Part No.	
	Tuner assembly	AWE-041-A	
	Equalizer amplifier assembly	AWF-011-0	
	Microphone amplifier assembly	AWM-064-0	
	Control amplifier assembly	AWG-029-0	
	Power amplifier assembly	AWH-031-A	
	Protection circuit assembly	AWM-025-C	
	Power supply circuit assembly	AWR-055-A	
	Switch & VR assembly	AWX-070-0	
	Switch circuit assembly (function)	AWS-073-0	
	Switch circuit assembly (FM muting)	AWS-075-0	
	Switch circuit assembly (mode, loudness)	AWS-065-0	
	Switch circuit assembly (filter, AF muting)	AWS-066-0	
	Switch circuit assembly (speakers)	AWS-074-0	
	Lamp board assembly	AWX-069-0	
	5P connector assembly	AWX-062-0	
	Wooden cabinet assembly	AMM-035-B	
	Phono jack - C (6 jacks)	AKB-016-0	
	Phono jack - A (4 jacks)	AKB-014-0	
	Phono jack (1 jack)	AKB-019-0	
	Antenna terminal board	AKA-002-0	

Symbol	Description	Part No.	
	Binding post for ground	AKE-012-A	
	Power transformer	ATT-168-A	KCU
	Power transformer	ATT-172-0	F
	Ferrite loopstick antenna	ATB-026-0	
	Balun	T22-025-A	
	Pilot lamp 8V, 0.3A (dial scale)	E22-032-0	
	Pilot lamp 8V, 0.3A (meter)	AEL-015-0	
	Pilot lamp 8V, 50mA (position)	AEL-022-0	
	Pilot lamp 8V, 50mA (position)	AEL-024-0	
	Fuse 4A (AC power)	AEK-100-0	KCU
	Fuse 3A (protection)	AEK-101-0	
	Fuse 1A (protection)	AEK-106-0	
	Fuse 2A (AC power)	AEK-103-0	F
	Fuse 4A (protection)	AEK-202-0	KCU
	AC socket	AKP-005-0	
	Speaker output terminal	AKE-014-0	
	Phone jack (Headphone)	K72-026-0	
	Jumper plug	AKM-004-A	
	Fuse holder (AC power)	AKR-001-0	F
	Pilot lamp socket	AKK-002-0	
	AC power cord	ADG-004-0	F
	AC power cord	ADG-005-0	KCU
	FM antenna	ADH-002-0	
	Operating instructions	ARB-101-0	
	Packing case	AHD-213-A	
	Side pad (L)	AHA-066-A	
	Side pad (R)	AHA-067-A	
	Inside packing	AHC-014-A	



2SA763P

HA1137

2SC461

2SC945

HA1138

2SC717

HA1156

HA1201

3SK45

2SA725

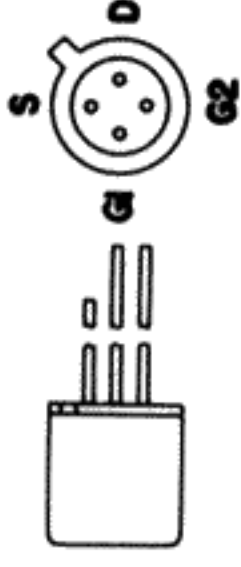
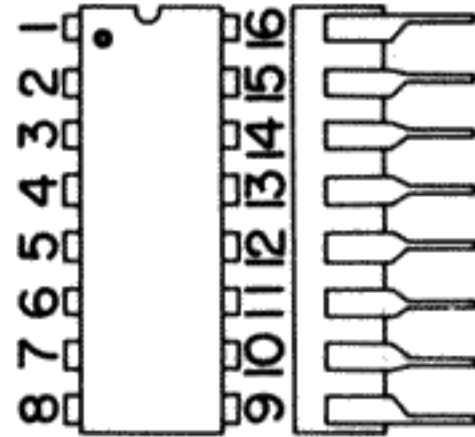
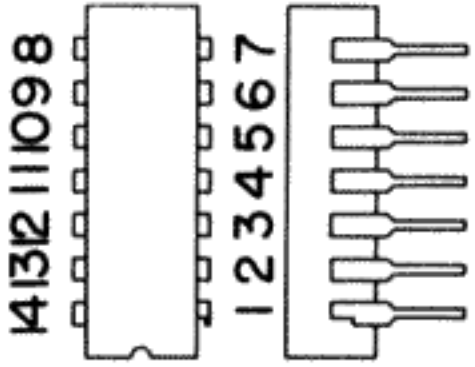

Foil Side (AWE-041-A)

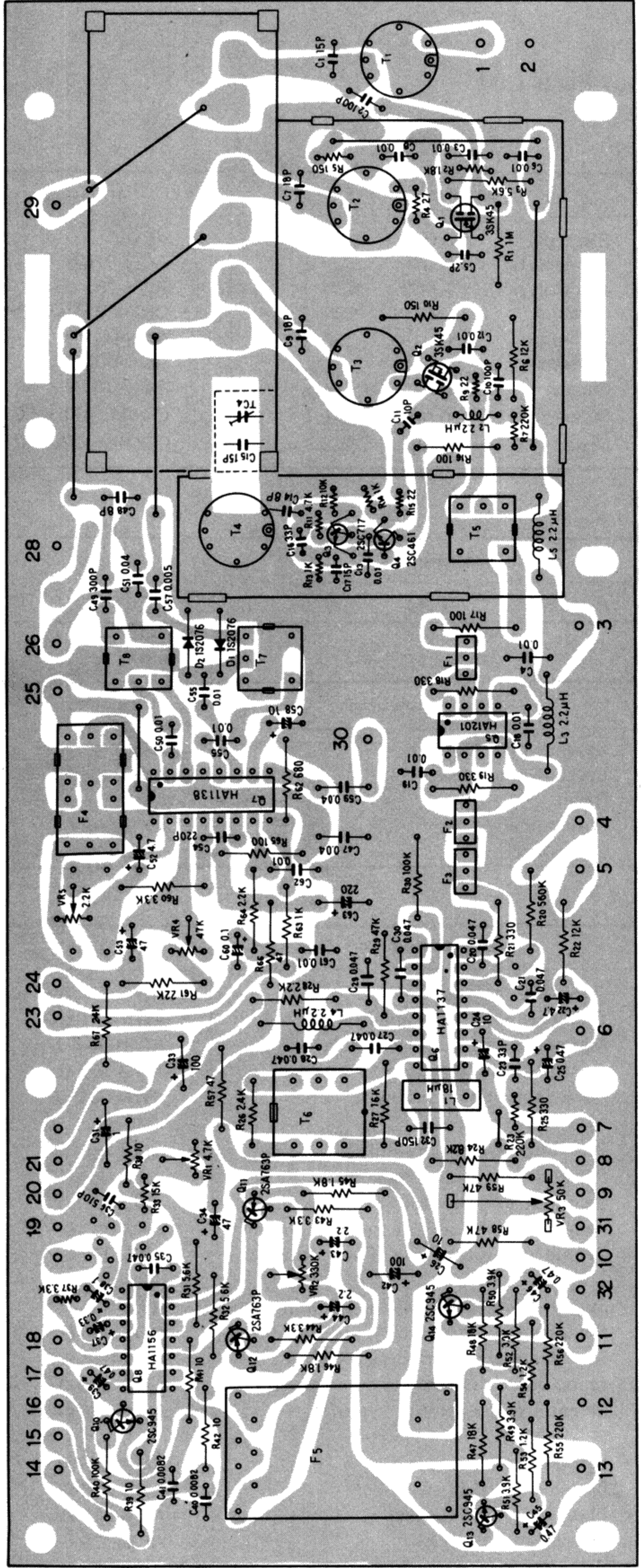

## Parts List of Tuner Assembly (AWE-041-A)

### RESISTORS AND POTENTIOMETERS

Symbol	Description	Part No.
R1	Carbon film 1M	RD¼PS 105J
R2	Carbon film 1.8k	RD¼VS 182J
R3	Carbon film 5.6k	RD¼PS 562J
R4	Carbon film 27	RD¼VS 270J
R5	Carbon film 150	RD¼VS 151J
R6	Carbon film 12k	RD¼PS 123J
R7	Carbon film 220k	RD¼VS 224J
R9	Carbon film 22	RD¼VS 220J
R10	Carbon film 150	RD¼PS 151J
R11	Carbon film 4.7k	RD¼VS 472J
R12	Carbon film 10k	RD¼VS 103J
R13	Carbon film 1k	RD¼VS 102J
R14	Carbon film 1k	RD¼VS 102J
R15	Carbon film 22	RD¼VS 220J
R16	Carbon film 100	RD¼PS 101J
R17	Carbon film 100	RD¼PS 101J
R18	Carbon film 330	RD¼PS 331J
R19	Carbon film 330	RD¼PS 331J
R20	Carbon film 560k	RD¼PS 564J
R21	Carbon film 330	RD¼PS 331J
R22	Carbon film 12k	RD¼PS 123J
R23	Carbon film 220k	RD¼VS 224J
R24	Carbon film 10k	RD¼PS 103J
R25	Carbon film 330	RD¼PS 331J
R26	Carbon film 2.4k	RD¼VS 242J
R27	Carbon film 16k	RD¼PS 163J
R28	Carbon film 2.2k	RD¼PS 222J
R29	Carbon film 47k	RD¼PS 473J
R30	Carbon film 100k	RD¼PS 104J
R31	Carbon film 5.6k	RD¼PS 562J
R32	Carbon film 5.6k	RD¼PS 562J
R33	Carbon film 15k	RD¼VS 153J
R36	Carbon film 150	RD¼PS 151J
R37	Carbon film 3.3k	RD¼VS 332J
R38	Carbon film 10	RD¼VS 100J
R39	Carbon film 10	RD¼PS 100J
R40	Carbon film 100k	RD¼PS 104J
R41	Carbon film 10	RD¼PS 100J
R42	Carbon film 10	RD¼PS 100J
R43	Carbon film 3.3k	RD¼PS 332J
R44	Carbon film 3.3k	RD¼PS 332J
R45	Carbon film 1.8k	RD¼PS 182J
R46	Carbon film 1.8k	RD¼PS 182J
R47	Carbon film 18k	RD¼PS 183J
R48	Carbon film 18k	RD¼PS 183J
R49	Carbon film 3.9k	RD¼PS 392J

Continued on the Next Page

Symbol	Description	Part No.
R50	Carbon film 3.9k	RD¼PS 392J
R51	Carbon film 3.9k	RD¼PS 392J
R52	Carbon film 3.9k	RD¼PS 392J
R53	Carbon film 1.2k	RD¼PS 122J
R54	Carbon film 1.2k	RD¼PS 122J
R55	Carbon film 220k	RD¼PS 224J
R56	Carbon film 220k	RD¼PS 224J
R57	Carbon film 47	RD¼PS 470J
R58	Carbon film 47k	RD¼PS 473J
R59	Carbon film 47k	RD¼PS 473J
R60	Carbon film 3.3k	RD¼PS 332J
R61	Carbon film 22k	RD¼PS 223J
R62	Carbon film 680	RD¼PS 681J
R63	Carbon film 1k	RD¼PS 102J
R64	Carbon film 2.2k	RD¼PS 222J
R65	Carbon film 100	RD¼PS 101J
R66	Carbon film 47	RD¼PS 470J
R67	Carbon film 24k	RD¼PS 243J
VR1	Variable resistor, semi-fixed 4.7k-B	C92-051-0
VR2	Variable resistor, semi-fixed 330k-B	ACP-042-0
VR3	Variable resistor, semi-fixed 50k-B	ACP-043-0
VR4	Variable resistor, semi-fixed 47k-B	C92-048-0
VR5	Variable resistor, semi-fixed 2.2k-B	ACP-001-0

## CAPACITORS

Symbol	Description	Part No.
VC	Tuning Capacitor	ACK-006-0
TC4	Ceramic Trimmer	C43-007-A
C1	Ceramic 15p 50V	CCDSH 150K 50
C2	Ceramic 100p 50V	CCDSL 101K 50
C3	Ceramic 0.01 50V	CKDYF 103Z 50
C4	Ceramic 0.01 50V	CKDYF 103Z 50
C5	Ceramic 2p 50V	CCDSL 020C 50
C6	Ceramic 0.01 50V	CKDYF 103Z 50
C7	Ceramic 18p 50V	CCDSH 180K 50
C8	Ceramic 0.01 50V	CKDYF 103Z 50
C9	Ceramic 18p 50V	CCDSH 180K 50
C10	Ceramic 100p 50V	CCDSL 101K 50
C11	Ceramic 10p 50V	CCDSL 100F 50
C12	Ceramic 0.01 50V	CKDYF 103Z 50
C13	Ceramic 0.01 50V	CKDYB 103K 50
C14	Ceramic 8p 50V	CCDLH 080F 50
C15	Ceramic 15p 50V	CCDLH 150K 50

Symbol	Description			Part No.
C16	Ceramic	33p	50V	CCDCH 330K 50
C17	Ceramic	15p	50V	CCDCH 150K 50
C18	Ceramic	0.01	50V	CKDYF 103Z 50
C19	Ceramic	0.01	50V	CKDYF 103Z 50
C20	Ceramic	0.047	25V	CKDBC 473Z 25
C21	Ceramic	0.047	25V	CKDBC 473Z 25
C22	Electrolytic	4.7	25V	CEA 4R7P 25
C23	Ceramic	33p	50V	CCDSL 330K 50
C24	Electrolytic	10	16V	CEA 100P 16
C25	Electrolytic	0.47	50V	CEA R47P 50
C26	Electrolytic	10	16V	CEA 100P 16
C27	Ceramic	0.047	25V	CKDBC 473Z 25
C28	Ceramic	0.047	25V	CKDBC 473Z 25
C29	Ceramic	0.047	25V	CKDBC 473Z 25
C30	Ceramic	0.047	25V	CKDBC 473Z 25
C31	Electrolytic	1	50V	CEA 010P 50
C32	Ceramic	150p	50V	CCDSL 151K 50
C33	Electrolytic	100	16V	CEA 101P 16
C34	Electrolytic	47	16V	CEA 470P 16
C35	Mylar	0.047	50V	CQMA 473K 50
C36	Styrol	510p	50V	CQSH 511J 50
C37	Electrolytic	0.33	25V	CSSA R33M 25
C38	Electrolytic	1	10V	CSSA 010M 10
C39	Electrolytic	0.47	25V	CSSA R47M 25
C40	Mylar	0.0082	50V	CQMA 822J 50
C41	Mylar	0.0082	50V	CQMA 822J 50
C42	Electrolytic	100	16V	CEA 101P 16
C43	Electrolytic	2.2	25V	CEA 2R2P 25
C44	Electrolytic	2.2	25V	CEA 2R2P 25
C45	Electrolytic	0.47	50V	CEA R47P 50
C46	Electrolytic	0.47	50V	CEA R47P 50
C47	Ceramic	0.04	50V	CKDYF 403Z 50
C48	Ceramic	8p	50V	CCDXL 080F 50
C49	Styrol	300p	50V	CQSA 301J 50
C50	Mylar	0.01	50V	CQMA 103K 50
C51	Ceramic	0.04	50V	CKDYF 403Z 50
C52	Electrolytic	4.7	25V	CEA 4R7P 25
C53	Electrolytic	47	6V	CEA 470P 6
C54	Ceramic	220p	50V	CCDSL 221K 50
C55	Ceramic	0.01	50V	CKDYF 103Z 50
C56	Ceramic	0.01	50V	CKDYF 103Z 50
C57	Ceramic	0.005	50V	CKDYF 502Z 50
C58	Electrolytic	10	16V	CEA 100P 16
C59	Ceramic	0.04	50V	CKDYF 403Z 50
C60	Electrolytic	0.1	25V	CSSA 0R1M 25
C61	Ceramic	0.01	50V	CKDYB 103K 50
C62	Ceramic	0.01	50V	CKDYB 103K 50
C63	Electrolytic	220	16V	CEA 221P 16
C64	Ceramic	0.005	50V	CKDYF 502Z 50

Continued on the Next Page

## SEMICONDUCTORS

Symbol	Description	Part No.
Q1	FET 3SK45-B	
Q2	FET 3SK45-B	
Q3	Transistor 2SC717	
Q4	Transistor 2SC461-B	
Q5	IC HA1201	
Q6	IC HA1137	
Q7	IC HA1138	
Q8	IC HA1156	
Q10	Transistor 2SC945-Q, R or S	
Q11	Transistor 2SA763P-6 or 5 (2SA725-F or G)	
Q12	Transistor 2SA763P-6 or 5 (2SA725-F or G)	
Q13	Transistor 2SC945-Q, R or S	
Q14	Transistor 2SC945-Q, R or S	
D1	Diode 1S2076	
D2	Diode 1S2076	

## COILS, FILTERS AND TRANSFORMERS

Symbol	Description	Part No.
T1	FM antenna coil	ATC-021-0
T2	FM RF coil	ATC-015-0
T3	FM RF coil	ATC-016-0
T4	FM OSC coil	ATC-022-0
T5	FM matching transformer	ATE-008-0
T6	FM IF transformer	T73-035-A
T7	AM RF coil	ATB-014-0
T8	AM OSC coil	ATB-013-0
F1	FM ceramic filter	ATF-013-B
F2	FM ceramic filter	ATF-013-B
F3	FM ceramic filter	ATF-013-B
F4	AM ceramic filter	ATF-009-0
F5	Low pass filter	ATF-019-0
L1	Choke coil	ATH-007-0
L2	RF choke coil	T24-028-A
L3	RF choke coil	T24-028-A
L4	RF choke coil	T24-028-A
L5	RF choke coil	T24-028-A

### 13. 3 EQUALIZER AMPLIFIER ASSEMBLY (AWF-011-0)

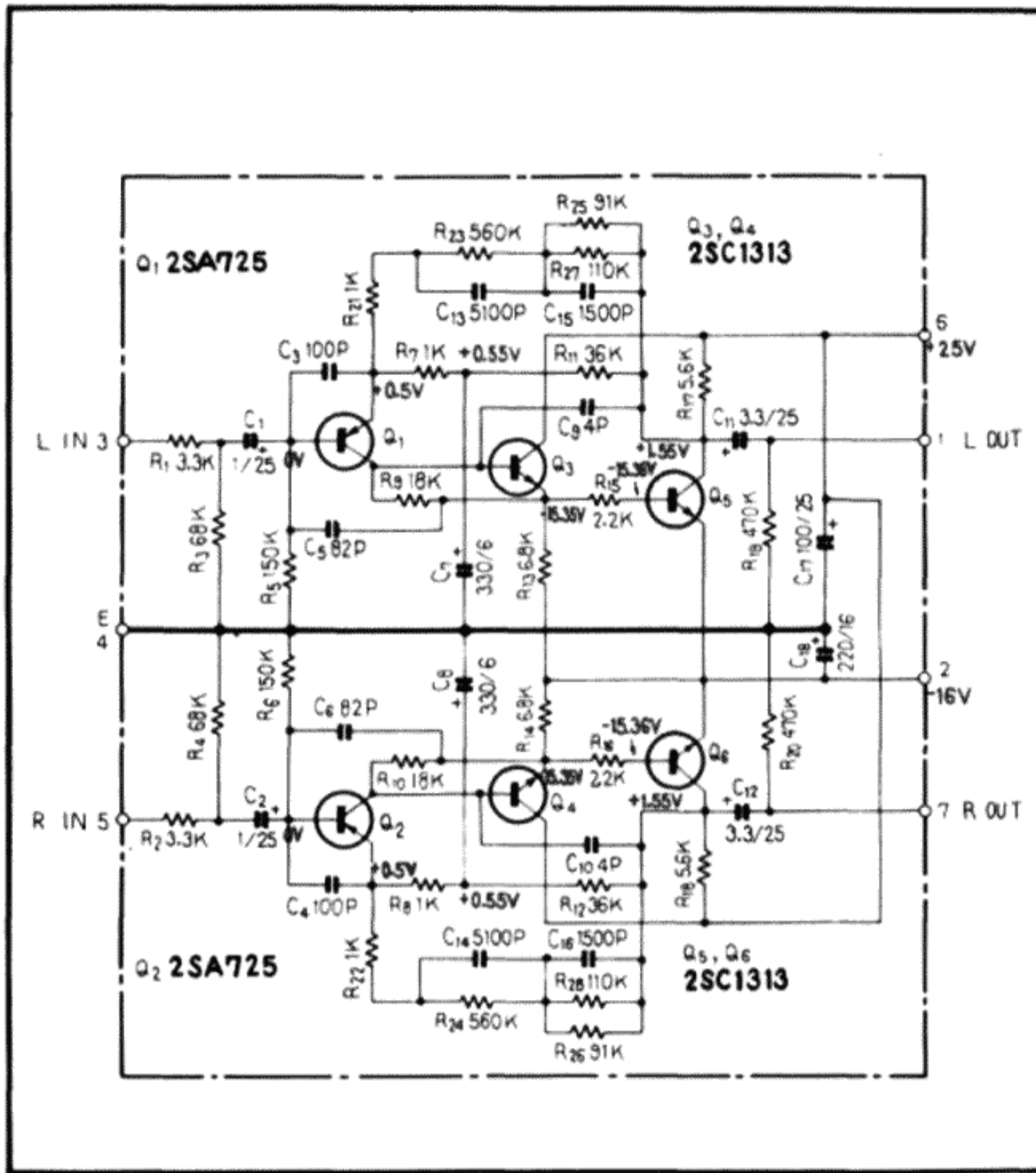

2SA725

2SC1313



2SC1345



2SA763P



### Foil Side (AWF-011-0)

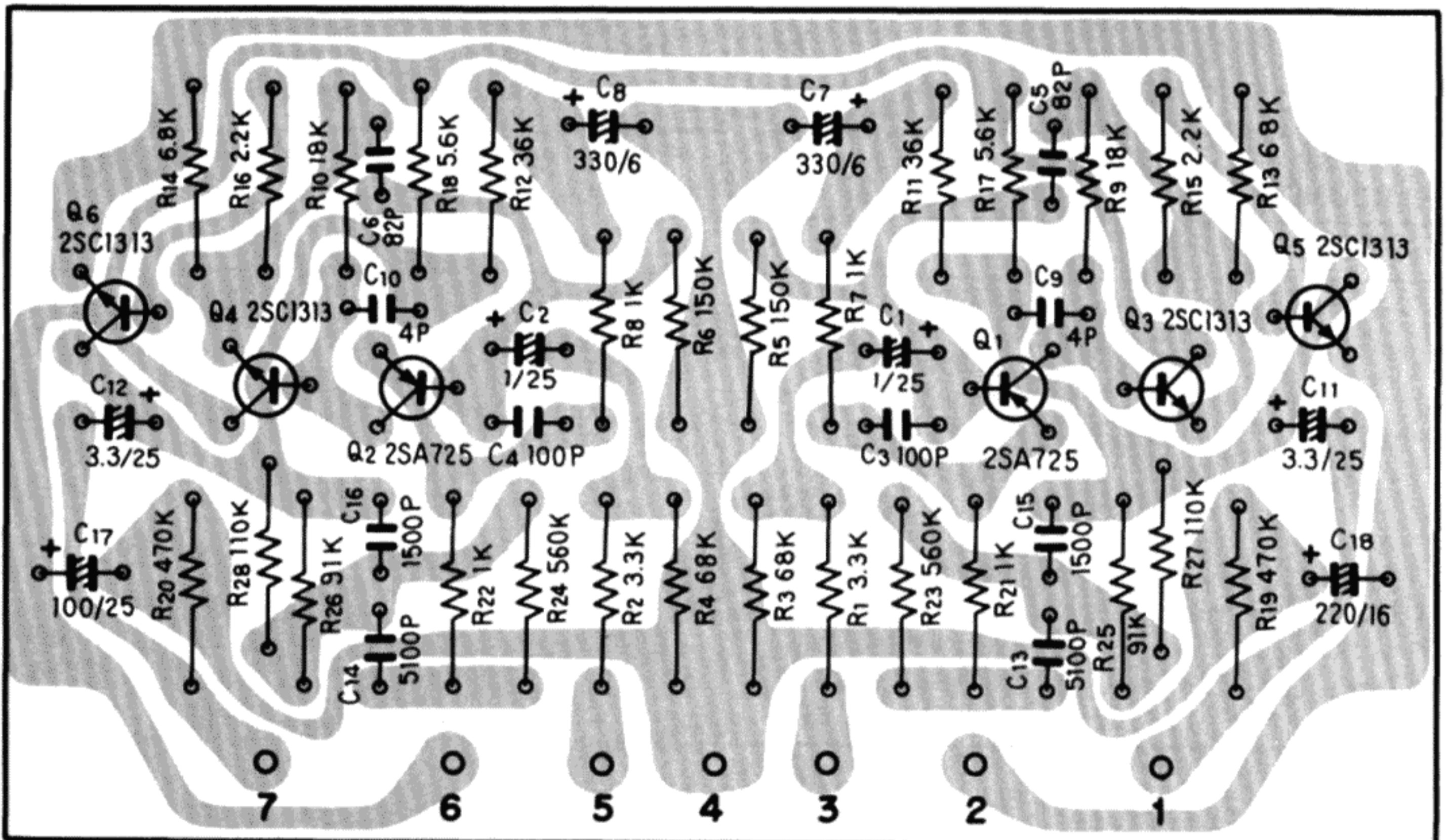

## Parts List of Equalizer Amplifier Assembly

### RESISTORS

Symbol	Description	Part No.
R1	Carbon film 3.3k	RD¼PS 332J
R2	Carbon film 3.3k	RD¼PS 332J
R3	Carbon film 68k	RD¼PS 683J
R4	Carbon film 68k	RD¼PS 683J
R5	Carbon film 150k	RD¼PS 154J
R6	Carbon film 150k	RD¼PS 154J
R7	Carbon film 1k	RD¼PS 102J
R8	Carbon film 1k	RD¼PS 102J
R9	Carbon film 18k	RD¼PS 183J
R10	Carbon film 18k	RD¼PS 183J
R11	Carbon film 36k	RD¼PS 363J
R12	Carbon film 36k	RD¼PS 363J
R13	Carbon film 6.8k	RD¼PS 682J
R14	Carbon film 6.8k	RD¼PS 682J
R15	Carbon film 2.2k	RD¼PS 222J
R16	Carbon film 2.2k	RD¼PS 222J
R17	Carbon film 5.6k	RD¼PS 562J
R18	Carbon film 5.6k	RD¼PS 562J
R19	Carbon film 470k	RD¼PS 474J NL
R20	Carbon film 470k	RD¼PS 474J NL
R21	Carbon film 1k	RD¼PS 102J
R22	Carbon film 1k	RD¼PS 102J
R23	Carbon film 560k	RD¼PS 564J NL
R24	Carbon film 560k	RD¼PS 564J NL
R25	Carbon film 91k	RD¼PS 913J
R26	Carbon film 91k	RD¼PS 913J
R27	Carbon film 110k	RD¼PS 114J
R28	Carbon film 110k	RD¼PS 114J

### SEMICONDUCTORS

Symbol	Description	Part No.
Q1	Transistor 2SA725-F or G (2SA763P-5 or 6)	
Q2	Transistor 2SA725-F or G (2SA763P-5 or 6)	
Q3	Transistor 2SC1313-G or F (2SC1345-E or D)	
Q4	Transistor 2SC1313-G or F (2SC1345-E or D)	
Q5	Transistor 2SC1313-G or F (2SC1345-E or D)	
Q6	Transistor 2SC1313-G or F (2SC1345-E or D)	

## CAPACITORS

Symbol	Description			Part No.	
C1	Electrolytic	1	25V	CSSA 010M 25	
C2	Electrolytic	1	25V	CSSA 010M 25	
C3	Ceramic	100p	50V	CCDSL 101K 50	
C4	Ceramic	100p	50V	CCDSL 101K 50	
C5	Ceramic	82p	50V	CCDSL 820K 50	
C6	Ceramic	82p	50V	CCDSL 820K 50	
C7	Electrolytic	330	6V	CEA 331P 6	
C8	Electrolytic	330	6V	CEA 331P 6	
C9	Ceramic	4p	50V	CCDSL 040D 50	
C10	Ceramic	4p	50V	CCDSL 040D 50	
C11	Electrolytic	3.3	25V	CEANL 3R3P 25	
C12	Electrolytic	3.3	25V	CEANL 3R3P 25	
C13	Styrol	0.0051	50V	CQSA 512G 50	
C14	Styrol	0.0051	50V	CQSA 512G 50	
C15	Styrol	0.0015	50V	CQSA 152G 50	
C16	Styrol	0.0015	50V	CQSA 152G 50	
C17	Electrolytic	100	25V	CEA 101P 25	
C18	Electrolytic	220	16V	CEA 221P 16	

### 13. 4 MICROPHONE AMPLIFIER ASSEMBLY (AWM-064-0)

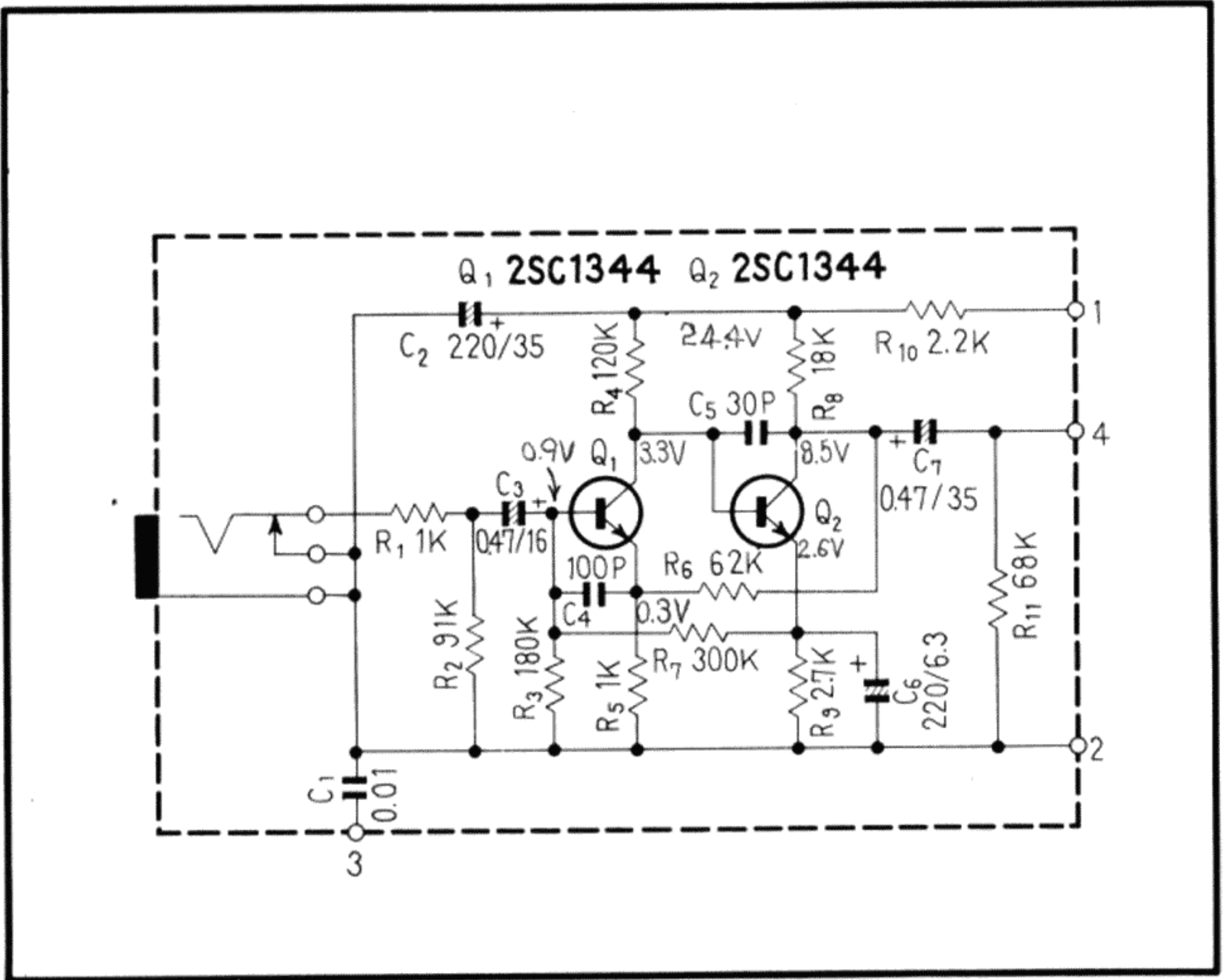

### Foil Side (AWM-064-0)

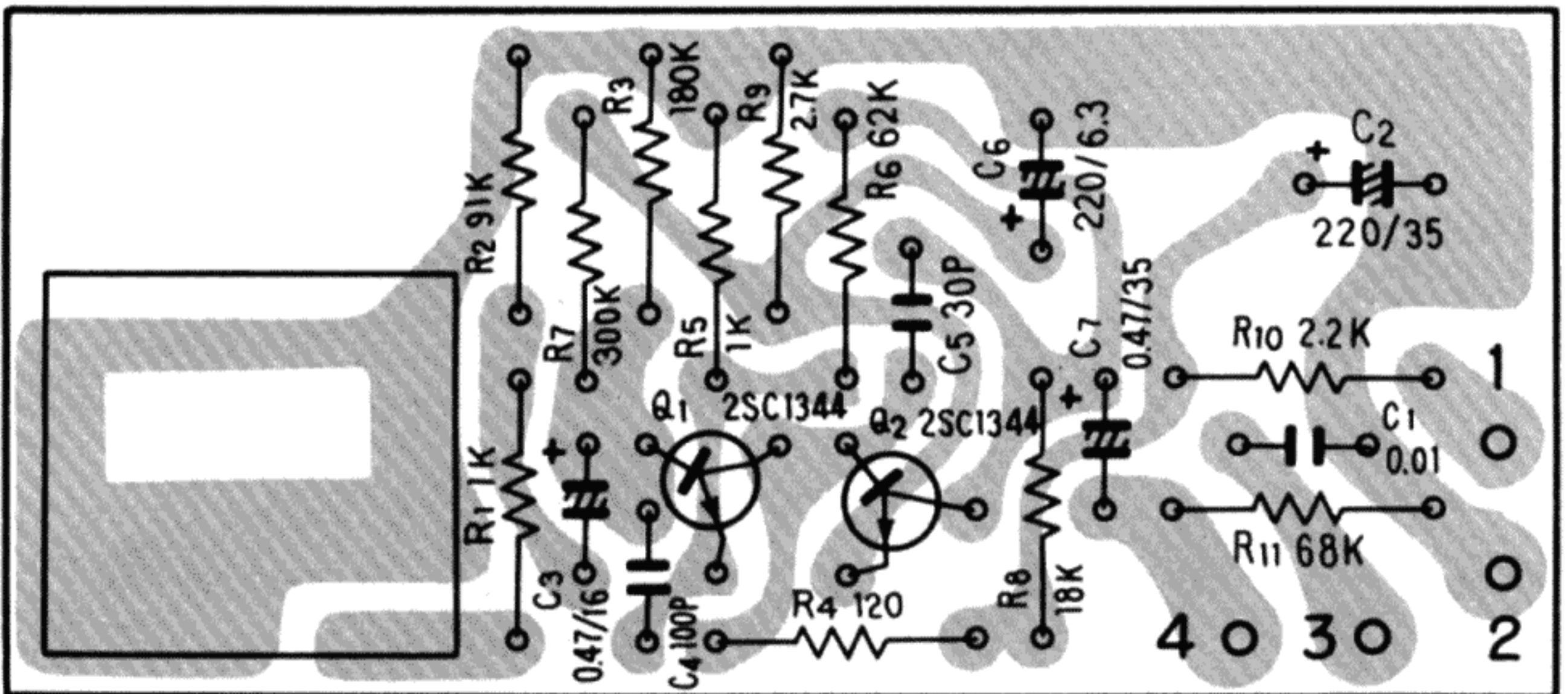

2SC1344



2SC1312



## Parts List of Microphone Amplifier Assembly

### OTHERS

Symbol	Description	Part No.	
	Phone jack (Microphe)	AKN-007-0	

### SEMICONDUCTORS

Symbol	Description	Part No.	
Q1	Transistor 2SC1344-E or D (2SC1312-G or F)		
Q2	Transistor 2SC1344-E or D (2SC1312-G or F)		

### CAPACITORS

Symbol	Description	Part No.	
C1	Ceramic 0.01 50V	CKDYF 103Z 50	
C2	Electrolytic 220 35V	CEA 221P 35	
C3	Electrolytic 0.47 16V	CSSA R47M 16	
C4	Ceramic 100p 50V	CCDSL 101K 50	
C5	Ceramic 30p 50V	CCDSL 300K 50	
C6	Electrolytic 220 6V	CEA 221P 6	
C7	Electrolytic 0.47 50V	CEANL R47P 50	

### RESISTORS

Symbol	Description	Part No.	
R1	Carbon film 1k	RD¼PM 102J	
R2	Carbon film 91k	RD¼PM 913J	
R3	Carbon film 180k	RD¼PM 184J	
R4	Carbon film 120k	RD¼PM 124J	
R5	Carbon film 1k	RD¼PM 102J	
R6	Carbon film 62k	RD¼PM 623J	
R7	Carbon film 300k	RD¼PM 304J	
R8	Carbon film 18k	RD¼PM 183J	
R9	Carbon film 2.7k	RD¼PM 272J	
R10	Carbon film 2.2k	RD¼PM 222J	
R11	Carbon film 68k	RD¼PM 683J	

# 13. 5 CONTROL AMPLIFIER ASSEMBLY (AWG-029-0)

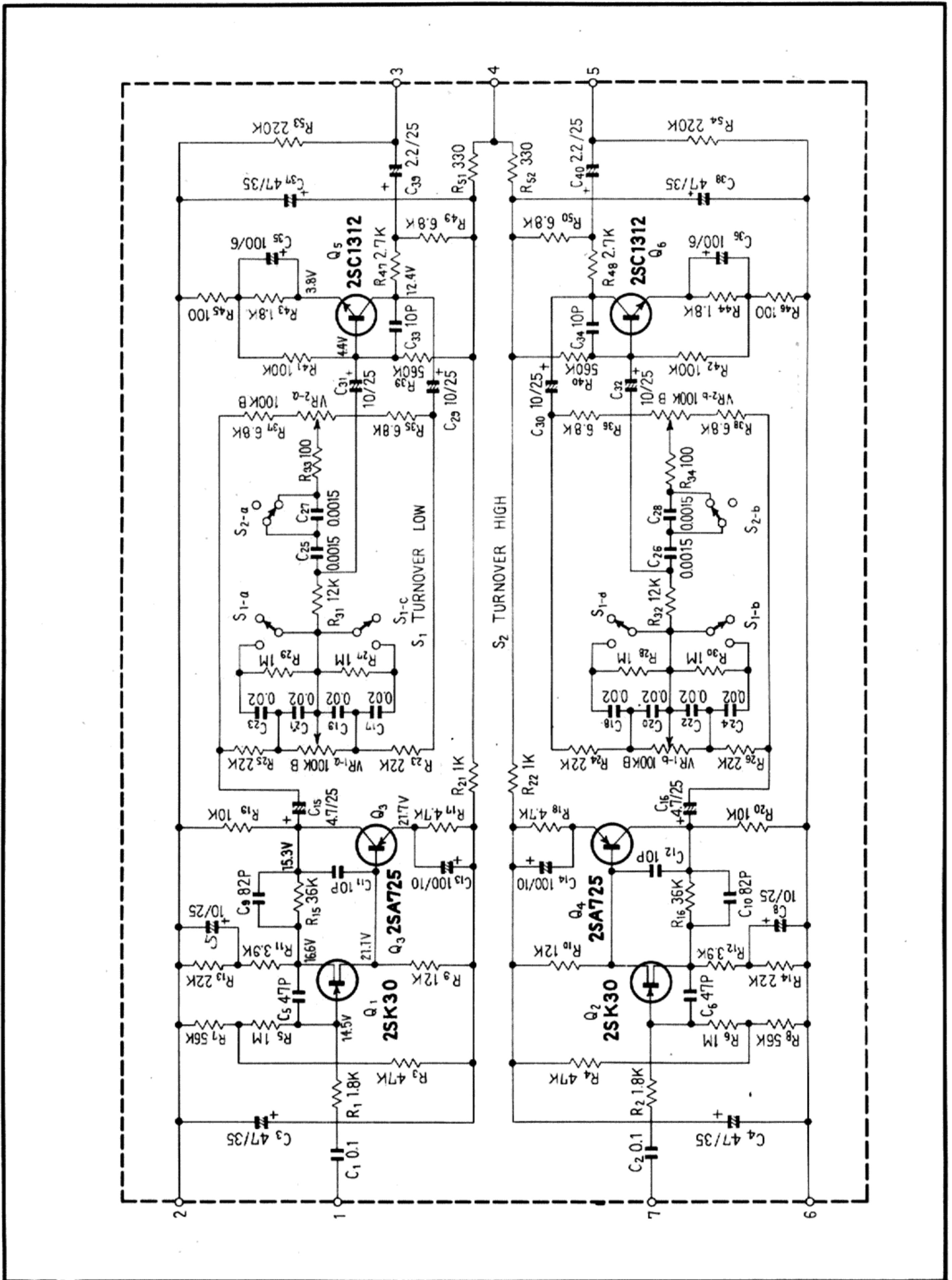

2SA725  
2SC1312

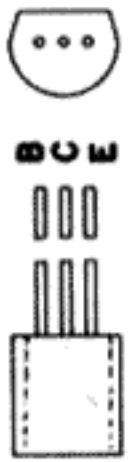

2SC1344

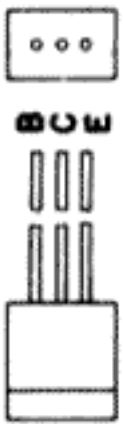

2SK30



Foil Side (AWG-029-0)

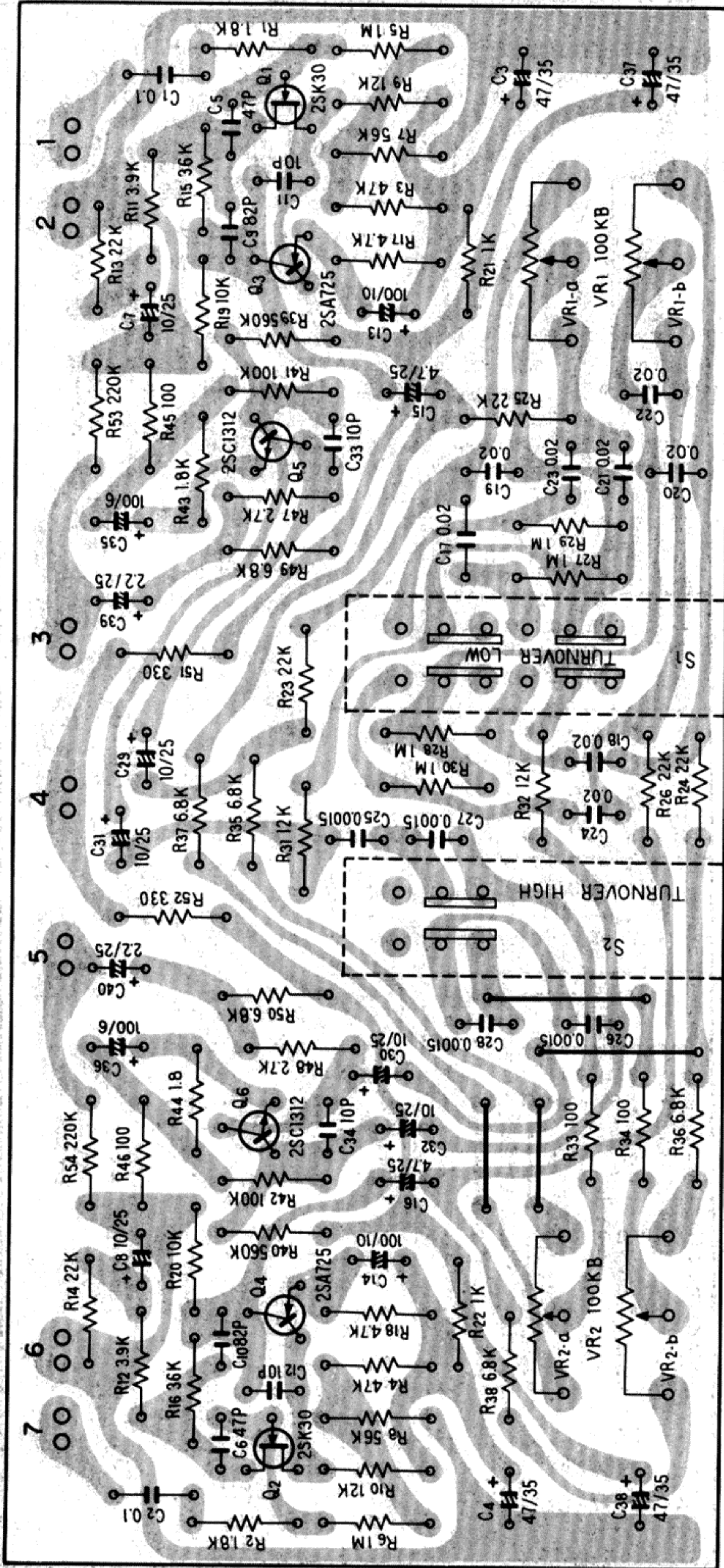

## Parts List of Control Amplifier Assembly

### SEMICONDUCTORS

Symbol	Description	Part No.
Q1	FET 2SK30-Y	
Q2	FET 2SK30-Y	
Q3	Transistor 2SA725-F or G	
Q4	Transistor 2SA725-F or G	
Q5	Transistor 2SC1312-F or G (2SC1344-D or E)	
Q6	Transistor 2SC1312-F or G (2SC1344-D or E)	

### CAPACITORS

Symbol	Description	Part No.
C1	Mylar 0.1 50V	CQMA 104K 50
C2	Mylar 0.1 50V	CQMA 104K 50
C3	Electrolytic 47 35V	CEA 470P 35
C4	Electrolytic 47 35V	CEA 470P 35
C5	Ceramic 47p 50V	CCDSL 470K 50
C6	Ceramic 47p 50V	CCDSL 470K 50
C7	Electrolytic 10 25V	CSZA 100P 25
C8	Electrolytic 10 25V	CSZA 100P 25
C9	Ceramic 82p 50V	CCDSL 820K 50
C10	Ceramic 82p 50V	CCDSL 820K 50
C11	Ceramic 10p 50V	CCDSL 100K 50
C12	Ceramic 10p 50V	CCDSL 100K 50
C13	Electrolytic 100 10V	CEA 101P 10
C14	Electrolytic 100 10V	CEA 101P 10
C15	Electrolytic 4.7 25V	CEANL 4R7P 25
C16	Electrolytic 4.7 25V	CEANL 4R7P 25
C17	Mylar 0.02 50V	CQMA 203J 50
C18	Mylar 0.02 50V	CQMA 203J 50
C19	Mylar 0.02 50V	CQMA 203J 50
C20	Mylar 0.02 50V	CQMA 203J 50
C21	Mylar 0.02 50V	CQMA 203J 50
C22	Mylar 0.02 50V	CQMA 203J 50
C23	Mylar 0.02 50V	CQMA 203J 50
C24	Mylar 0.02 50V	CQMA 203J 50
C25	Mylar 0.0015 50V	CQMA 152J 50
C26	Mylar 0.0015 50V	CQMA 152J 50
C27	Mylar 0.0015 50V	CQMA 152J 50
C28	Mylar 0.0015 50V	CQMA 152J 50
C29	Electrolytic 10 25V	CSZA 100P 25
C30	Electrolytic 10 25V	CSZA 100P 25
C31	Electrolytic 10 25V	CSZA 100P 25
C32	Electrolytic 10 25V	CSZA 100P 25
C33	Ceramic 10p 50V	CCDSL 100K 50
C34	Ceramic 10p 50V	CCDSL 100K 50
C35	Electrolytic 100 6V	CEA 101P 6

Symbol	Description	Part No.
C36	Electrolytic 100 6V	CEA 101P 6
C37	Electrolytic 47 35V	CEA 470P 35
C38	Electrolytic 47 35V	CEA 470P 35
C39	Electrolytic 2.2 25V	CSZA 2R2M 25
C40	Electrolytic 2.2 25V	CSZA 2R2M 25

## RESISTORS AND POTENTIOMETERS

Symbol	Description	Part No.
VR1	Variable resistor (100k-B)	ACV-136-0
VR2	Variable resistor (100k-B)	ACV-136-0
R1	Carbon film 1.8k	RD¼PM 182J
R2	Carbon film 1.8k	RD¼PM 182J
R3	Carbon film 47k	RD¼PM 473J
R4	Carbon film 47k	RD¼PM 473J
R5	Carbon film 1M	RD¼PM 105J
R6	Carbon film 1M	RD¼PM 105J
R7	Carbon film 56k	RD¼PM 563J
R8	Carbon film 56k	RD¼PM 563J
R9	Carbon film 12k	RD¼PM 123J
R10	Carbon film 12k	RD¼PM 123J
R11	Carbon film 3.9k	RD¼PM 392J
R12	Carbon film 3.9k	RD¼PM 392J
R13	Carbon film 22k	RD¼PM 223J
R14	Carbon film 22k	RD¼PM 223J
R15	Carbon film 36k	RD¼PM 363J
R16	Carbon film 36k	RD¼PM 363J
R17	Carbon film 4.7k	RD¼PM 472J
R18	Carbon film 4.7k	RD¼PM 472J
R19	Carbon film 10k	RD¼PM 103J
R20	Carbon film 10k	RD¼PM 103J
R21	Carbon film 1k	RD¼PM 102J
R22	Carbon film 1k	RD¼PM 102J
R23	Carbon film 22k	RD¼PM 223J
R24	Carbon film 22k	RD¼PM 223J
R25	Carbon film 22k	RD¼PM 223J
R26	Carbon film 22k	RD¼PM 223J
R27	Carbon film 1M	RD¼PM 105J
R28	Carbon film 1M	RD¼PM 105J
R29	Carbon film 1M	RD¼PM 105J
R30	Carbon film 1M	RD¼PM 105J
R31	Carbon film 12k	RD¼PM 123J
R32	Carbon film 12k	RD¼PM 123J
R33	Carbon film 100	RD¼PM 101J
R34	Carbon film 100	RD¼PM 101J
R35	Carbon film 6.8k	RD¼PM 682J
R36	Carbon film 6.8k	RD¼PM 682J
R37	Carbon film 6.8k	RD¼PM 682J
R38	Carbon film 6.8k	RD¼PM 682J

Symbol	Description	Part No.
R39	Carbon film 560k	RD¼PM 564J
R40	Carbon film 560k	RD¼PM 564J
R41	Carbon film 100k	RD¼PM 104J
R42	Carbon film 100k	RD¼PM 104J
R43	Carbon film 1.8k	RD¼PM 182J
R44	Carbon film 1.8k	RD¼PM 182J
R45	Carbon film 100	RD¼PM 101J
R46	Carbon film 100	RD¼PM 101J
R47	Carbon film 2.7k	RD¼PM 272J
R48	Carbon film 2.7k	RD¼PM 272J
R49	Carbon film 6.8k	RD¼PM 682J
R50	Carbon film 6.8k	RD¼PM 682J
R51	Carbon film 330	RD¼PM 331J
R52	Carbon film 330	RD¼PM 331J
R53	Carbon film 220k	RD¼PM 224J
R54	Carbon film 220k	RD¼PM 224J

### SWITCHES

Symbol	Description	Part No.
S1	Lever switch (Turn over low)	ASK-071-0
S2	Lever switch (Turn over high)	ASK-069-0

# 13. 6 POWER AMPLIFIER ASSEMBLY (AWH-031-A)

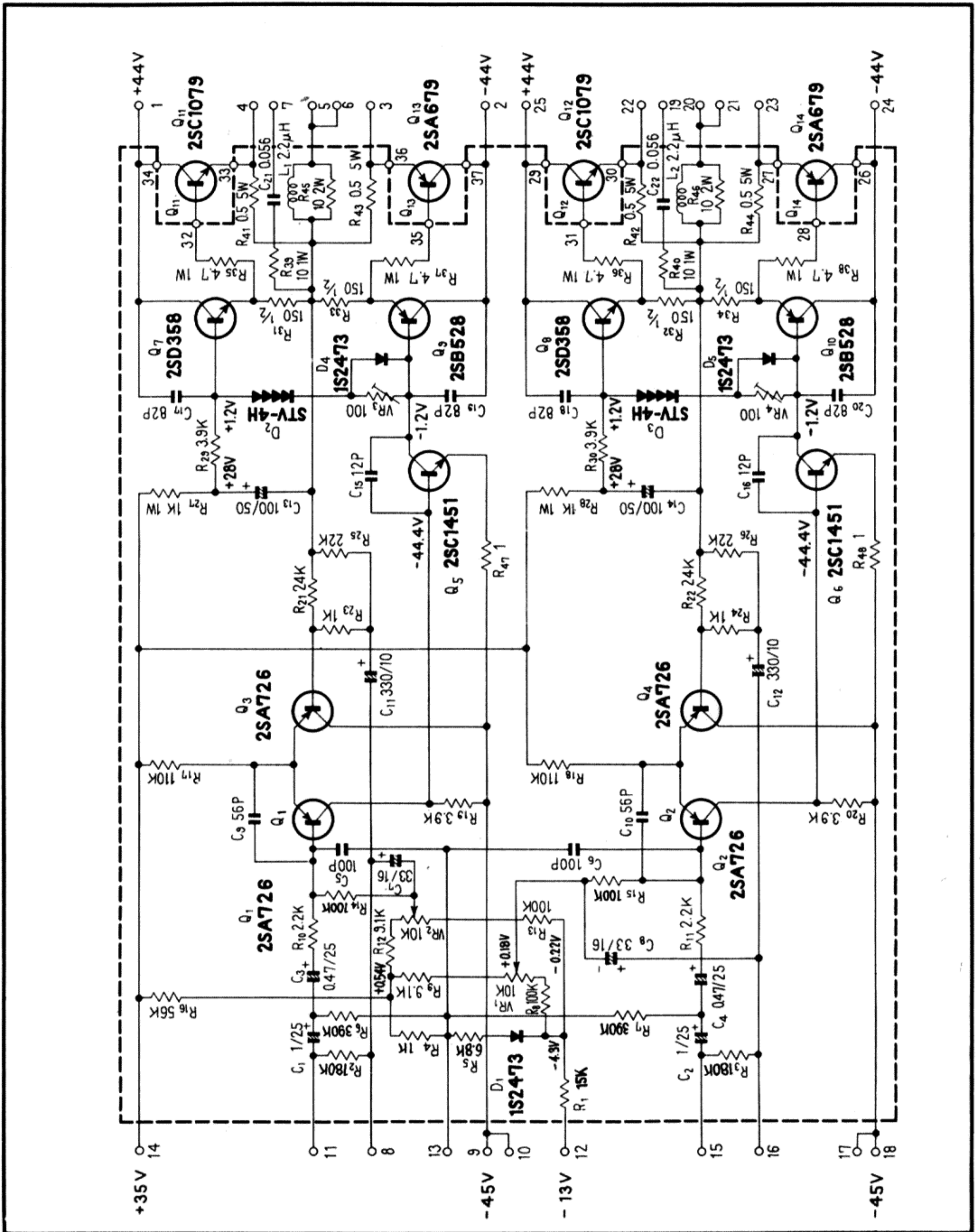

2SA679  
 2SA747  
 2SB539  
 2SD287  
 2SC1079

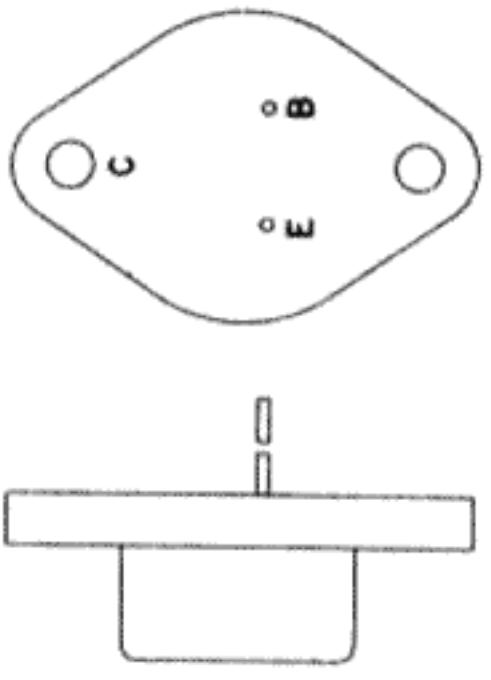

2SB528  
 2SD358

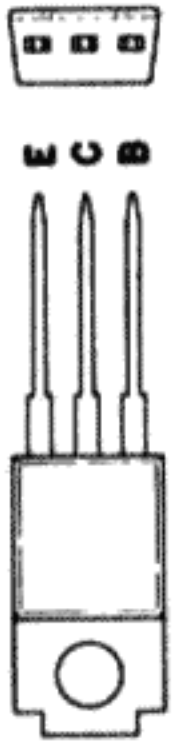

2SC1451

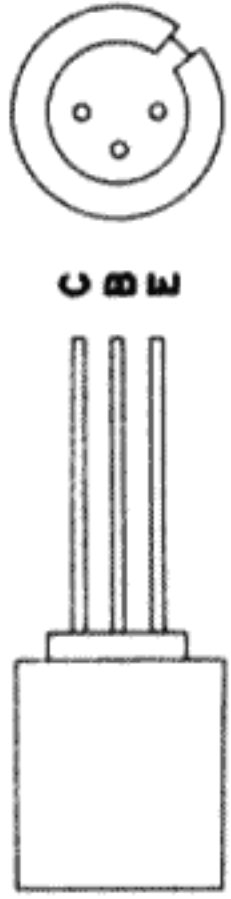

2SA726

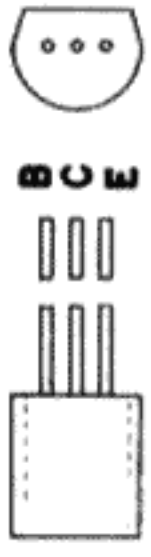

2SC1116

Q14 2SA679

Q12 2SC1079

Q11 2SC1079

Q13 2SA679

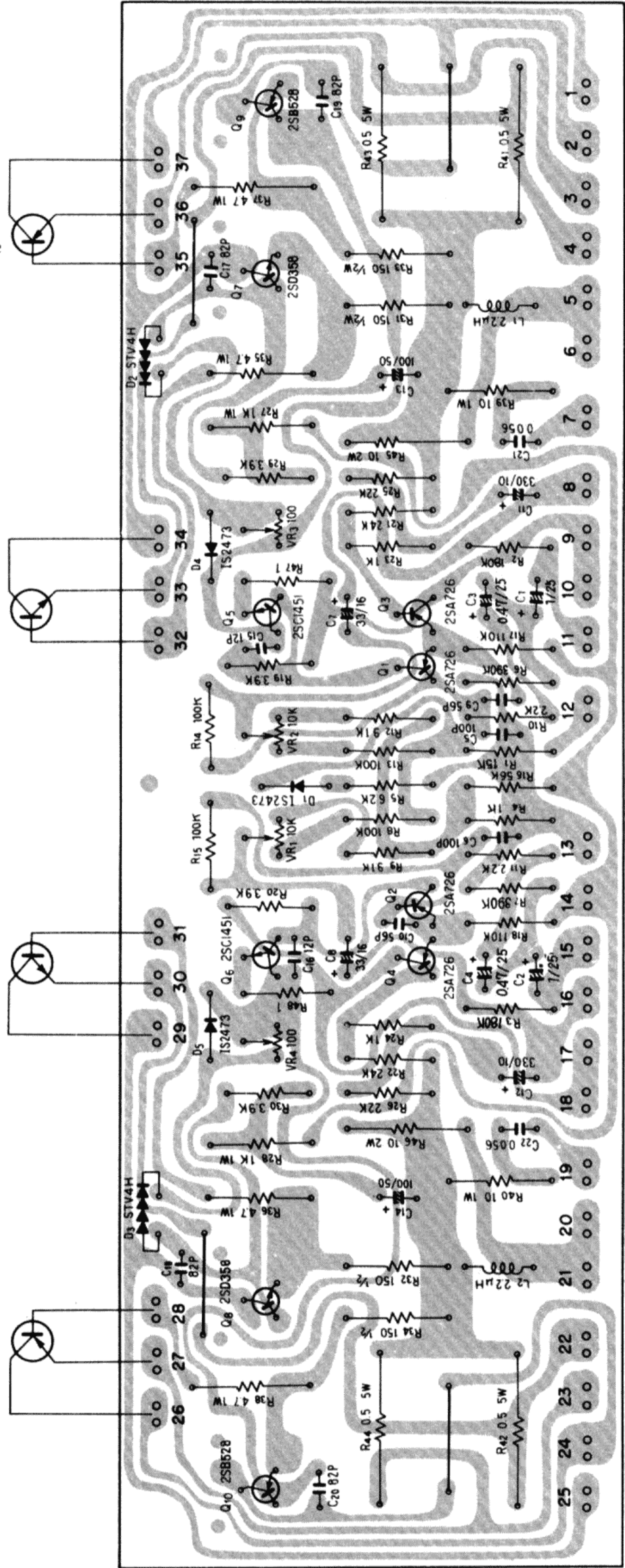

Foil Side (AWH-031-A)

## Parts List of Power Amplifier Assembly (AWH-031-A)

### SEMICONDUCTORS

Symbol	Description	Part No.
Q1	Transistor 2SA726-F or G	
Q2	Transistor 2SA726-F or G	
Q3	Transistor 2SA726-F or G	
Q4	Transistor 2SA726-F or G	
Q5	Transistor 2SC1451-V or B	
Q6	Transistor 2SC1451-V or B	
Q7	Transistor 2SB528-C or D	
Q8	Transistor 2SB528-C or D	
Q9	Transistor 2SD358-C or D	
Q10	Transistor 2SD358-C or D	
Q11	Transistor 2SC1079-R or Y (2SC1116-R, O or Y) (2SD287-L or M)	
Q13	Transistor 2SC1079-R or Y (2SC1116-R, O or Y) (2SD287-L or M)	
Q12	Transistor 2SA679-R or Y (2SA747-R, O or Y) (2SB539-L or M)	
Q14	Transistor 2SA679-R or Y (2SA747-R, O or Y) (2SB539-L or M)	
D1	Diode 1S2473	
D2	Varistor STV-4H	
D3	Varistor STV-4H	
D4	Diode 1S2473	
D5	Diode 1S2473	

### RESISTORS AND POTENTIOMETERS

Symbol	Description	Part No.
VR1	Variable resistor 100k-B	ACP-029-A
VR2	Variable resistor 100k-B	ACP-029-A
VR3	Variable resistor 100-B	ACP-019-B
VR4	Variable resistor 100-B	ACP-019-B
R1	Carbon film 15k	RD $\frac{1}{4}$ PS 153J
R2	Carbon film 180k	RD $\frac{1}{4}$ PS 184J
R3	Carbon film 180k	RD $\frac{1}{4}$ PS 184J
R4	Carbon film 1k	RD $\frac{1}{4}$ PS 102J
R5	Carbon film 6.8k	RD $\frac{1}{4}$ PS 682J
R6	Carbon film 390k	RD $\frac{1}{4}$ PS 394J

Continued on the Next Page

Symbol	Description			Part No.
R7	Carbon film	390k		RD¼PS 394J
R8	Carbon film	100k		RD¼PS 104J
R9	Carbon film	9.1k		RD¼PS 912J
R10	Carbon film	2.2k		RD¼PS 222J
R11	Carbon film	2.2k		RD¼PS 222J
R12	Carbon film	9.1k		RD¼PS 912J
R13	Carbon film	100k		RD¼PS 104J
R14	Carbon film	100k		RD¼PS 104J
R15	Carbon film	100k		RD¼PS 104J
R16	Carbon film	56k		RD¼PS 563J
R17	Carbon film	110k		RD¼PS 114J
R18	Carbon film	110k		RD¼PS 114J
R19	Carbon film	3.9k		RD¼PS 392J
R20	Carbon film	3.9k		RD¼PS 392J
R21	Carbon film	24k		RD¼PS 243J
R22	Carbon film	24k		RD¼PS 243J
R23	Carbon film	1k		RD¼PS 102J
R24	Carbon film	1k		RD¼PS 102J
R25	Carbon film	22k		RD¼PS 223J
R26	Carbon film	22k		RD¼PS 223J
R27	Metal oxide	1k	1W	RS1P 102J
R28	Metal oxide	1k	1W	RS1P 102J
R29	Carbon film	3.9k		RD¼PS 392J
R30	Carbon film	3.9k		RD¼PS 392J
R31	Carbon film	150	½W	RD½PS 151J
R32	Carbon film	150	½W	RD½PS 151J
R33	Carbon film	150	½W	RD½PS 151J
R34	Carbon film	150	½W	RD½PS 151J
R35	Metal film	4.7	1W	RN1H 4R7K
R36	Metal film	4.7	1W	RN1H 4R7K
R37	Metal film	4.7	1W	RN1H 4R7K
R38	Metal film	4.7	1W	RN1H 4R7K
R39	Metal oxide	10	1W	RS1P 100J
R40	Metal oxide	10	1W	RS1P 100J
R41	Wire wound	0.5	5W	RT5B 0R5K
R42	Wire wound	0.5	5W	RT5B 0R5K
R43	Wire wound	0.5	5W	RT5B 0R5K
R44	Wire wound	0.5	5W	RT5B 0R5K
R45	Metal oxide	10	2W	RS2P 100J
R46	Metal oxide	10	2W	RS2P 100J
R47	Carbon film	1		RD¼PS 010J
R48	Carbon film	1		RD¼PS 010J

## CAPACITORS

Symbol	Description	Part No.
C1	Electrolytic 1 25V	CSSA 010M 25
C2	Electrolytic 1 25V	CSSA 010M 25
C3	Electrolytic 0.47 25V	CSSA R47M 25
C4	Electrolytic 0.47 25V	CSSA R47M 25
C5	Ceramic 100p 50V	CCDSL 101K 50
C6	Ceramic 100p 50V	CCDSL 101K 50
C7	Electrolytic 33 16V	CEA 330P 16
C8	Electrolytic 33 16V	CEA 330P 16
C9	Ceramic 56p 50V	CCDSL 560K 50
C10	Ceramic 56p 50V	CCDSL 560K 50
C11	Electrolytic 330 10V	CEA 331P 10
C12	Electrolytic 330 10V	CEA 331P 10
C13	Electrolytic 100 50V	CEA 101P 50
C14	Electrolytic 100 50V	CEA 101P 50
C15	Ceramic 12p 500V	CCDSL 120K 500
C16	Ceramic 12p 500V	CCDSL 120K 500
C17	Ceramic 82p 500V	CCDSL 820K 500
C18	Ceramic 82p 500V	CCDSL 820K 500
C19	Ceramic 82p 500V	CCDSL 820K 500
C20	Ceramic 82p 500V	CCDSL 820K 500
C21	Mylar 0.056 50V	CQMA 563M 50
C22	Mylar 0.056 50V	CQMA 563M 50

## OTHERS

Symbol	Description	Part No.
L1	AF choke coil	T63-009-0
L2	AF choke coil	T63-009-0
	Socket (power transistor)	AKH-001-0
	Spacer (insulator)	AEC-076-0
	Heat sink	ANH-117-0
	Fuse holder	AKR-013-0

### 13. 7 PROTECTION CIRCUIT ASSEMBLY (AWM-025-C)

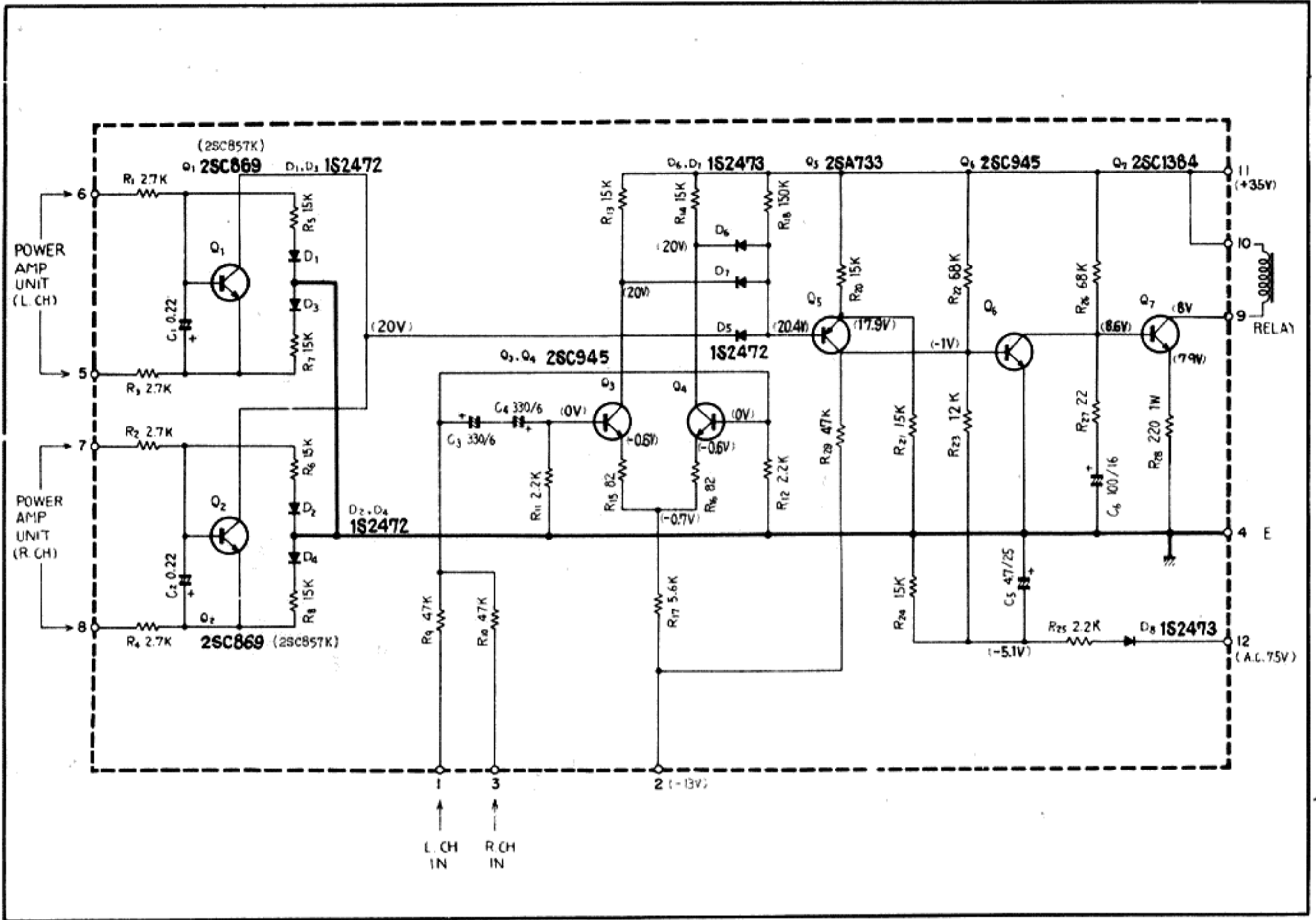

### Foil Side (AWM-025-C)

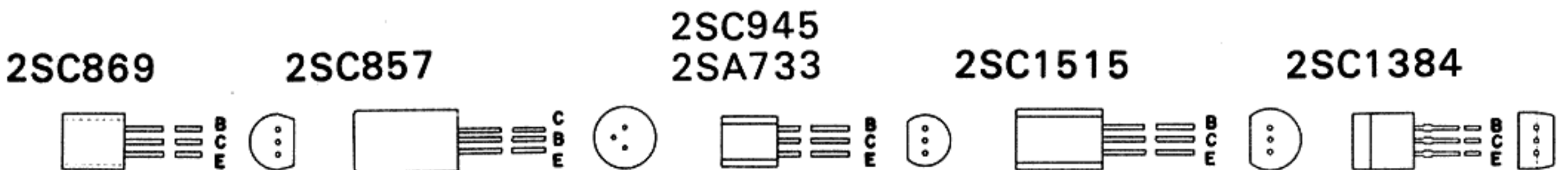
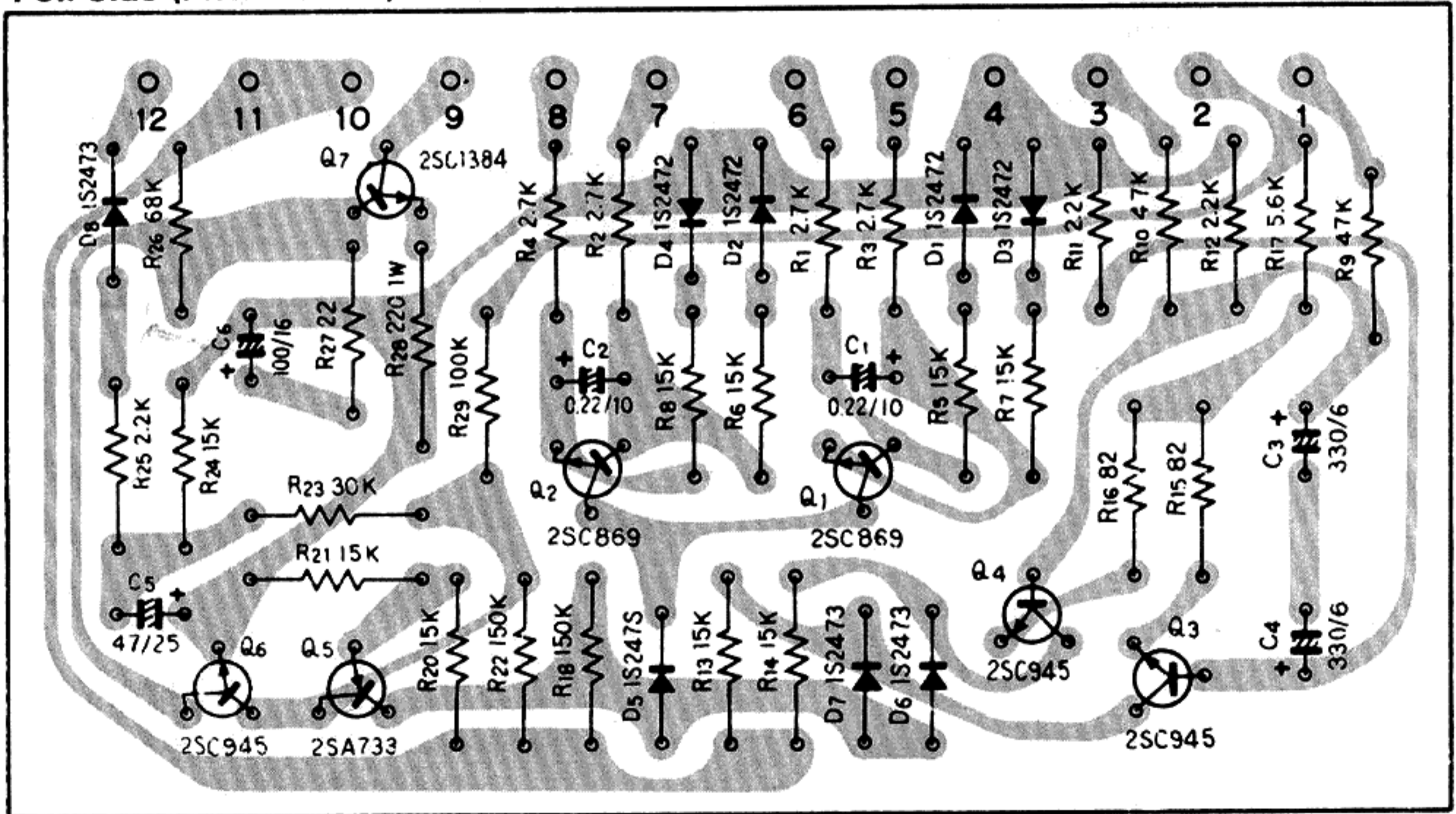

## Parts List of Protection Circuit Assembly (AWM-025-C)

### SEMICONDUCTORS

Symbol	Description	Part No.
Q1	Transistor 2SC869-C, B or D (2SC857K-A) (2SC1515K)	
Q2	Transistor 2SC869-C, B or D (2SC857K-A) (2SC1515K)	
Q3	Transistor 2SC945-Q or R	
Q4	Transistor 2SC945-Q or R	
Q5	Transistor 2SA733-Q or R	
Q6	Transistor 2SC945-Q or R	
Q7	Transistor 2SC1384-R or Q	
D1	Diode 1S2472	
D2	Diode 1S2472	
D3	Diode 1S2472	
D4	Diode 1S2472	
D5	Diode 1S2472	
D6	Diode 1S2473	
D7	Diode 1S2473	
D8	Diode 1S2473	

### RESISTORS

Symbol	Description	Part No.
R1	Carbon film 2.7k	RD¼PS 272J
R2	Carbon film 2.7k	RD¼PS 272J
R3	Carbon film 2.7k	RD¼PS 272J
R4	Carbon film 2.7k	RD¼PS 272J
R5	Carbon film 15k	RD¼PS 153J
R6	Carbon film 15k	RD¼PS 153J
R7	Carbon film 15k	RD¼PS 153J
R8	Carbon film 15k	RD¼PS 153J
R9	Carbon film 47k	RD¼PS 473J
R10	Carbon film 47k	RD¼PS 473J
R11	Carbon film 2.2k	RD¼PS 222J
R12	Carbon film 2.2k	RD¼PS 222J
R13	Carbon film 15k	RD¼PS 153J
R14	Carbon film 15k	RD¼PS 153J
R15	Carbon film 82	RD¼PS 820J
R16	Carbon film 82	RD¼PS 820J
R17	Carbon film 5.6k	RD¼PS 562J
R18	Carbon film 150k	RD¼PS 154J
R20	Carbon film 15k	RD¼PS 153J
R21	Carbon film 15k	RD¼PS 153J

Symbol	Description			Part No.
R22	Carbon film	68k		RD¼PS 683J
R23	Carbon film	12k		RD¼PS 123J
R24	Carbon film	15k		RD¼PS 153J
R25	Carbon film	2.2k		RD¼PS 222J
R26	Carbon film	68k		RD¼PS 683J
R27	Carbon film	22		RD¼PS 220J
R28	Metal oxide	220	1W	RS1P 221J
R29	Carbon film	47k		RD¼PS 473J

## CAPACITORS

Symbol	Description			Part No.
C1	Electrolytic	0.22	10V	CSSA R22M 10
C2	Electrolytic	0.22	10V	CSSA R22M 10
C3	Electrolytic	330	6V	CEA 331P 6
C4	Electrolytic	330	6V	CEA 331P 6
C5	Electrolytic	4.7	25V	CEA 4R7P 25
C6	Electrolytic	100	16V	CEA 101P 16

### 13. 8 POWER SUPPLY CIRCUIT ASSEMBLY (AWR-055-0)

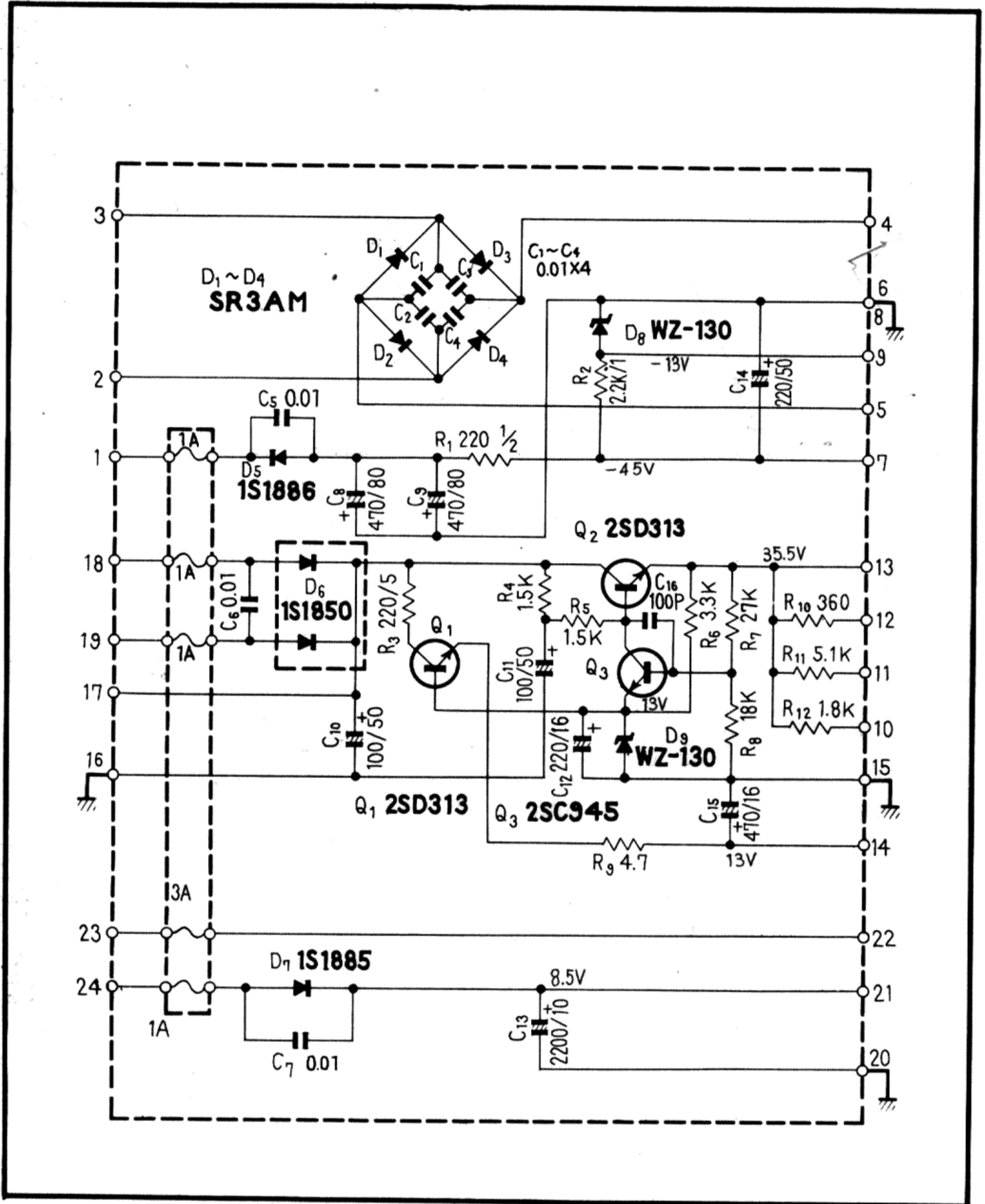

2SC945



2SD313

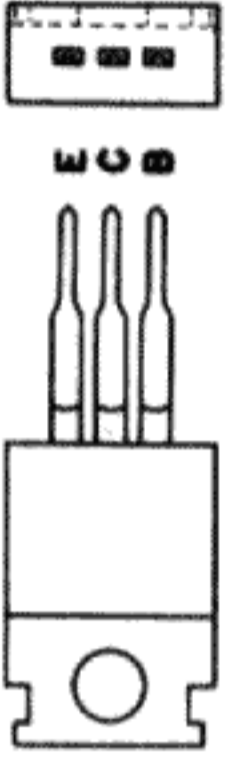

Foil Side (AWR-055-0)

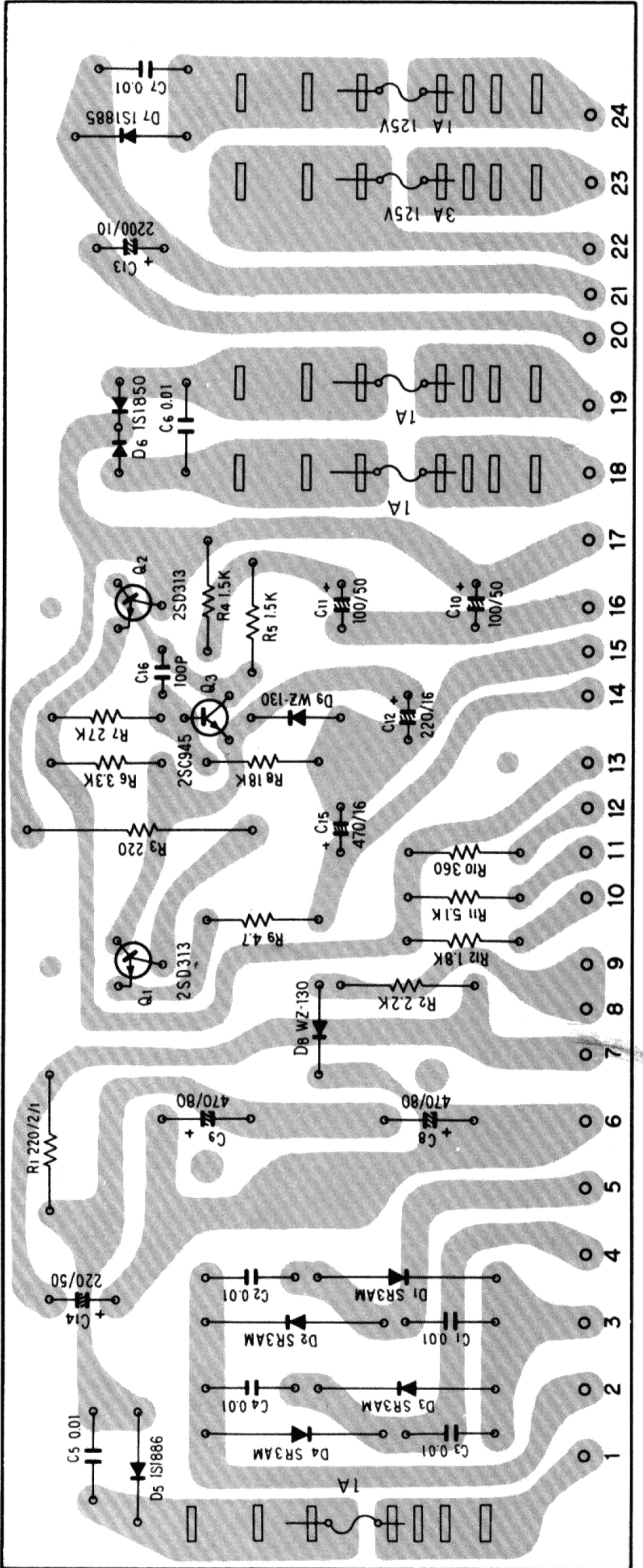

## Parts List of Power Supply Circuit Assembly (AWR-055-0)

### SEMICONDUCTORS

Symbol	Description	Part No.
Q1	Transistor 2SD313-E	
Q2	Transistor 2SD313P-E or D	
Q3	Transistor 2SC945-Q or R	
D1	Diode SR3AM-8	
D2	Diode SR3AM-8	
D3	Diode SR3AM-8	
D4	Diode SR3AM-8	
D5	Diode 1S1886	
D6	Diode 1S1850	
D7	Diode 1S1885	
D8	Zener diode WZ-130	
D9	Zener diode WZ-130	

### RESISTORS

Symbol	Description	Part No.
R1	Carbon film 220 ½W	RD½PS 221J
R2	Metal oxide 2.2k 1W	RS1P 222K
R3	Wire wound 220 5W	RT5B 221K
R4	Carbon film 1.5k	RD¼PS 152J
R5	Carbon film 1.5k	RD¼PS 152J
R6	Carbon film 3.3k	RD¼PS 332J
R7	Carbon film 27k	RD¼PS 273J
R8	Carbon film 18k	RD¼PS 183J
R9	Carbon film 4.7	RD¼PS 4R7J
R10	Carbon film 360	RD¼PS 361J
R11	Carbon film 5.1k	RD¼PS 512J
R12	Carbon film 1.8k	RD¼PS 182J

### CAPACITORS

Symbol	Description	Part No.
C1	Ceramic 0.01 150V	ACG-004-0
C2	Ceramic 0.01 150V	ACG-004-0
C3	Ceramic 0.01 150V	ACG-004-0
C4	Ceramic 0.01 150V	ACG-004-0
C5	Ceramic 0.01 150V	ACG-004-0
C6	Ceramic 0.01 150V	ACG-004-0
C7	Ceramic 0.01 150V	ACG-004-0
C8	Electrolytic 470 80V	ACH-038-0
C9	Electrolytic 470 80V	ACH-038-0
C10	Electrolytic 100 50V	CEA 101P 50
C11	Electrolytic 100 50V	CEA 101P 50
C12	Electrolytic 220 16V	CEA 221P 16
C13	Electrolytic 2,200 10V	CEA 222P 10
C14	Electrolytic 220 50V	CEA 221P 50
C15	Electrolytic 470 16V	CEA 471P 16
C16	Ceramic 100p 50V	CCDSL 101K 50

# 13. 9 SWITCH & VOLUME ASSEMBLY (AWX-070-0)

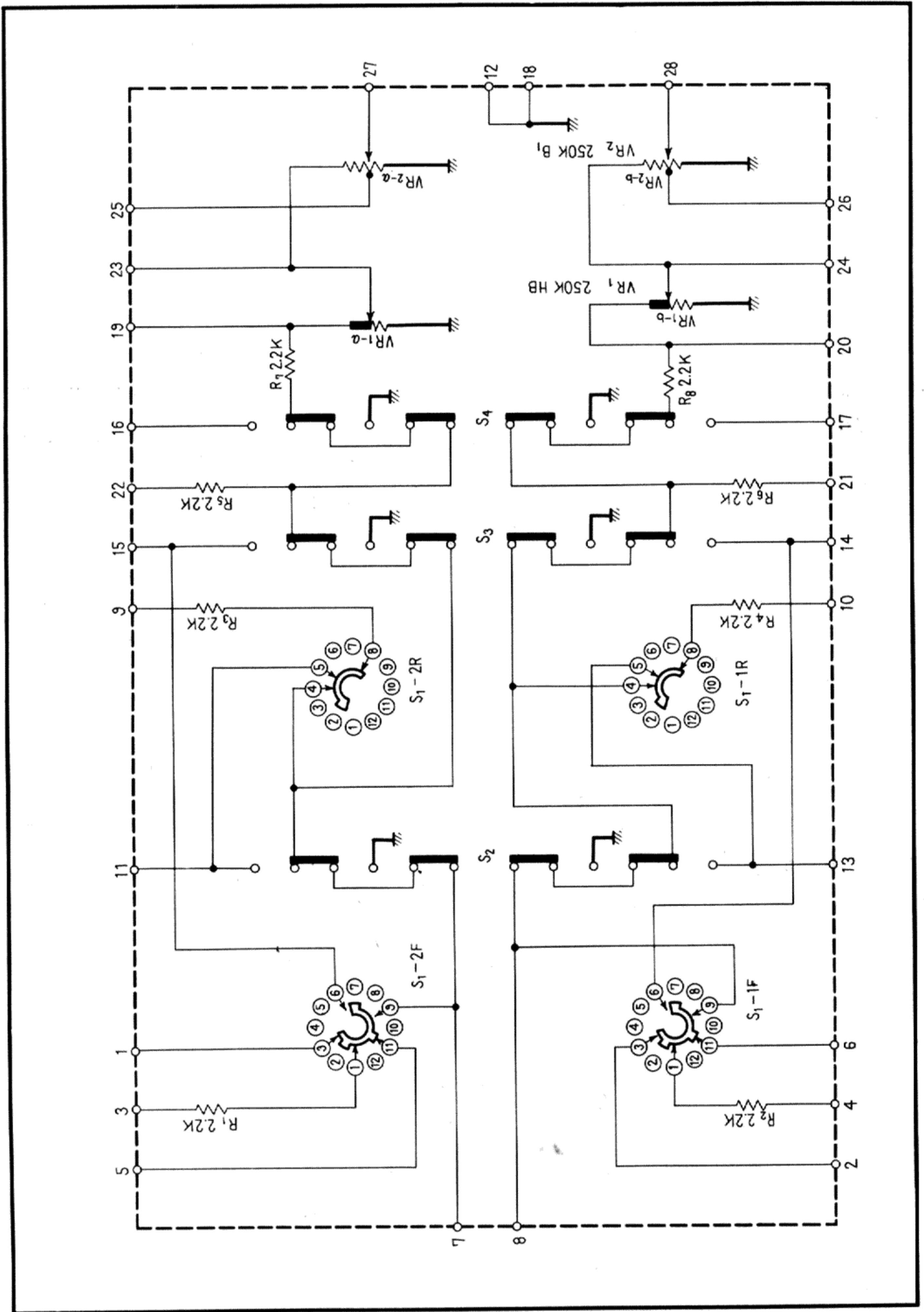

Foil Side (AWX-070-0)

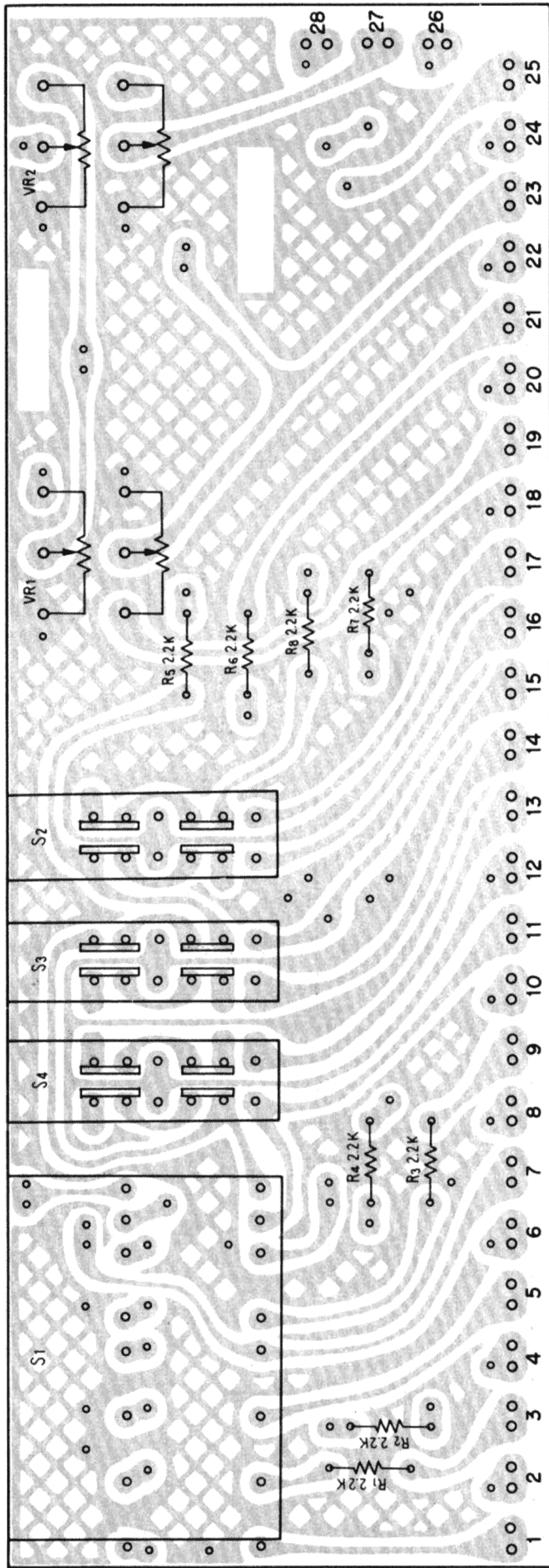

## Parts List of Switch & Volume Assembly (AWX-070-0)

Symbol	Description	Part No.
VR1	Variable resistor 250k-HB (Balance)	ACV-135-0
VR2	Variable resistor 250k-B1 (Volume)	ACV-134-0
S1	Rotary switch (Rec selector)	ASD-017-0
S2	Lever switch (Monitor 1)	ASK-072-0
S3	Lever switch (Monitor 2)	ASK-072-0
S4	Lever switch (NR adaptor)	ASK-072-0
R1	Carbon film 2.2k	RD¼PS 222J
R2	Carbon film 2.2k	RD¼PS 222J
R3	Carbon film 2.2k	RD¼PS 222J
R4	Carbon film 2.2k	RD¼PS 222J
R5	Carbon film 2.2k	RD¼PS 222J
R6	Carbon film 2.2k	RD¼PS 222J
R7	Carbon film 2.2k	RD¼PS 222J
R8	Carbon film 2.2k	RD¼PS 222J

# 13.10 SWITCH CIRCUIT ASSEMBLY (AWS-073-0)

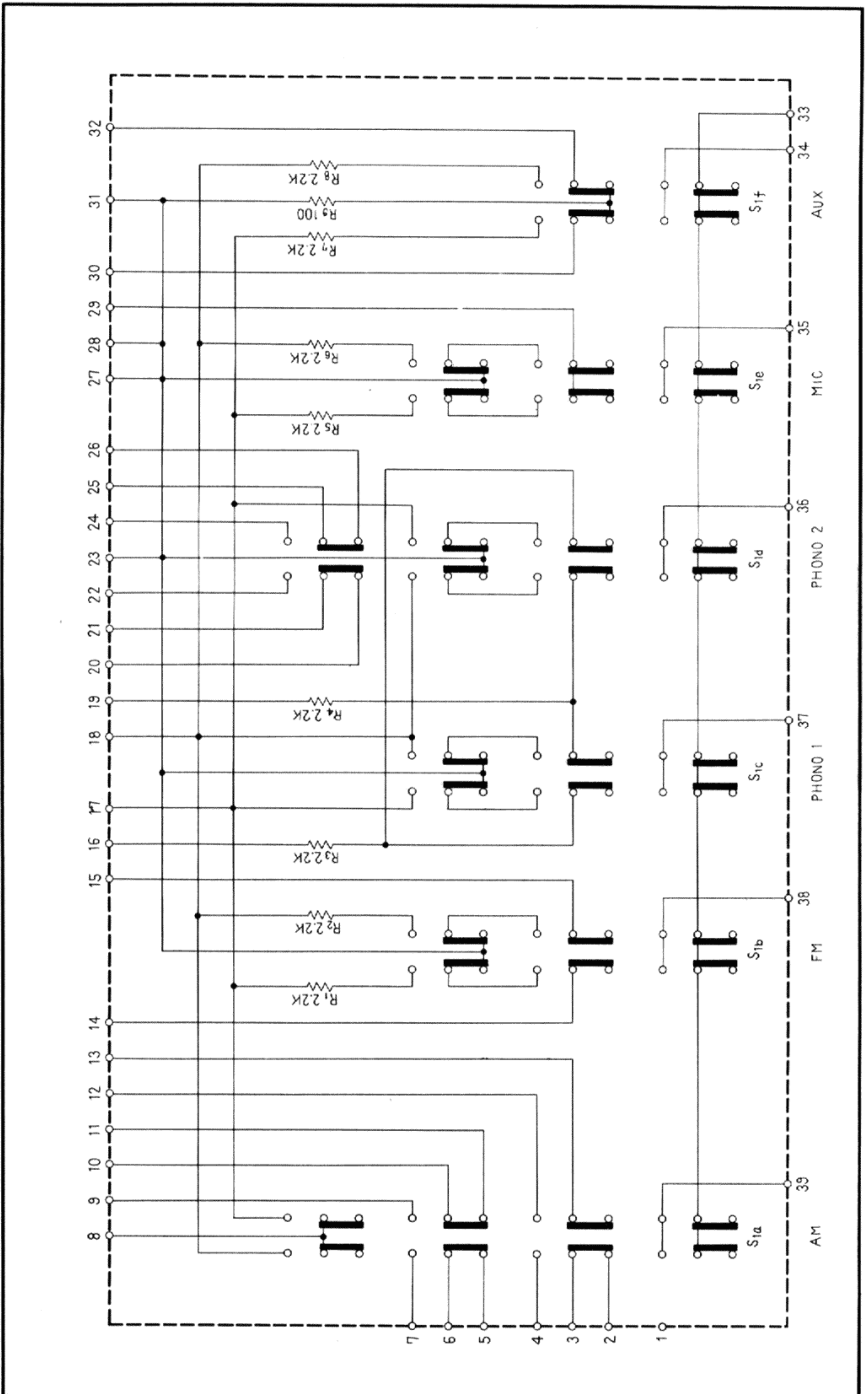

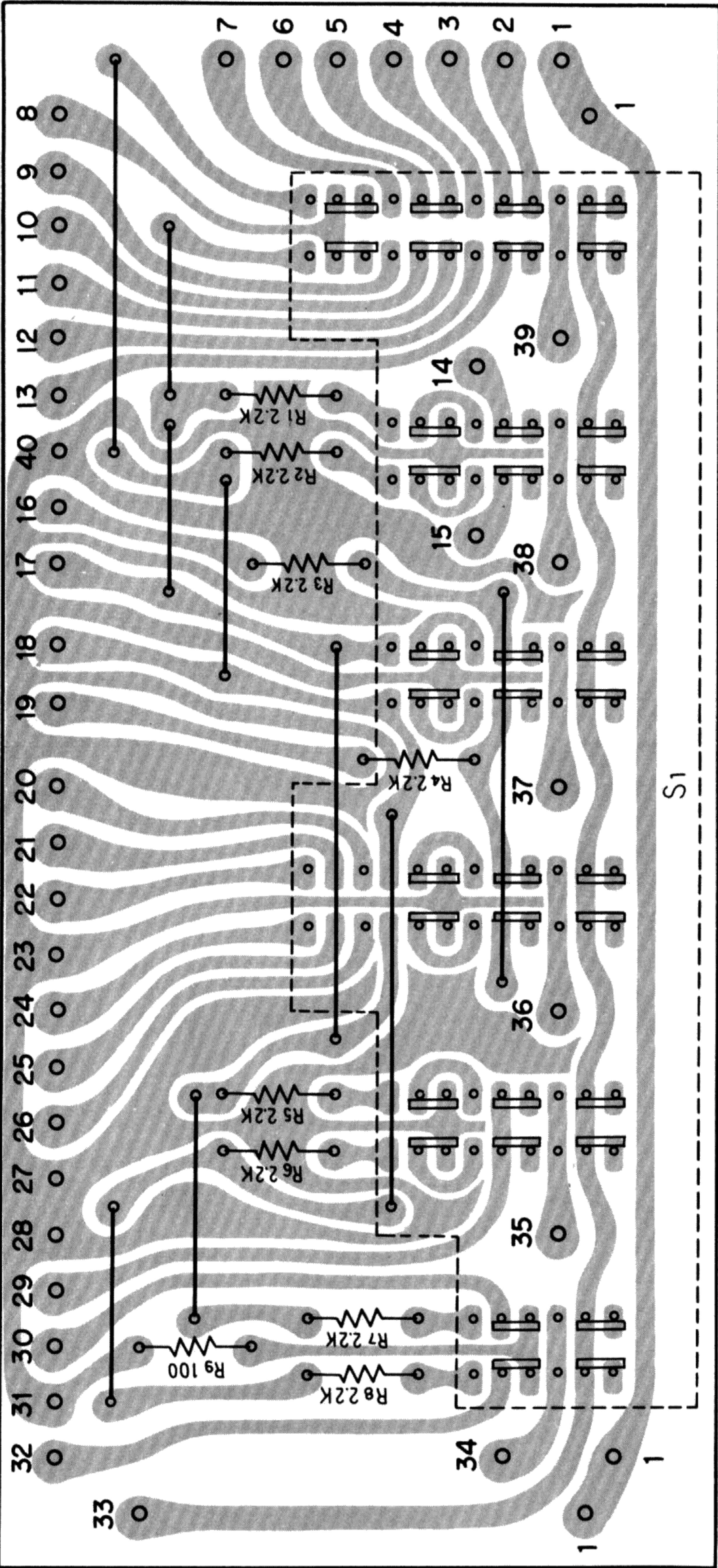

Foil Side (AWS-073-0)

## Parts List of Switch Circuit Assembly (AWS-073-0)

### SWITCH AND RESISTORS

Symbol	Description	Part No.
S1	Push switch (Function)	ASG-069-A
R1	Carbon film 2.2k	RD¼PM 222J
R2	Carbon film 2.2k	RD¼PM 222J
R3	Carbon film 2.2k	RD¼PM 222J
R4	Carbon film 2.2k	RD¼PM 222J
R5	Carbon film 2.2k	RD¼PM 222J
R6	Carbon film 2.2k	RD¼PM 222J
R7	Carbon film 2.2k	RD¼PM 222J
R8	Carbon film 2.2k	RD¼PM 222J
R9	Carbon film 100	RD¼PM 101J

### 13.11 SWITCH CIRCUIT ASSEMBLY (AWS-065-0)

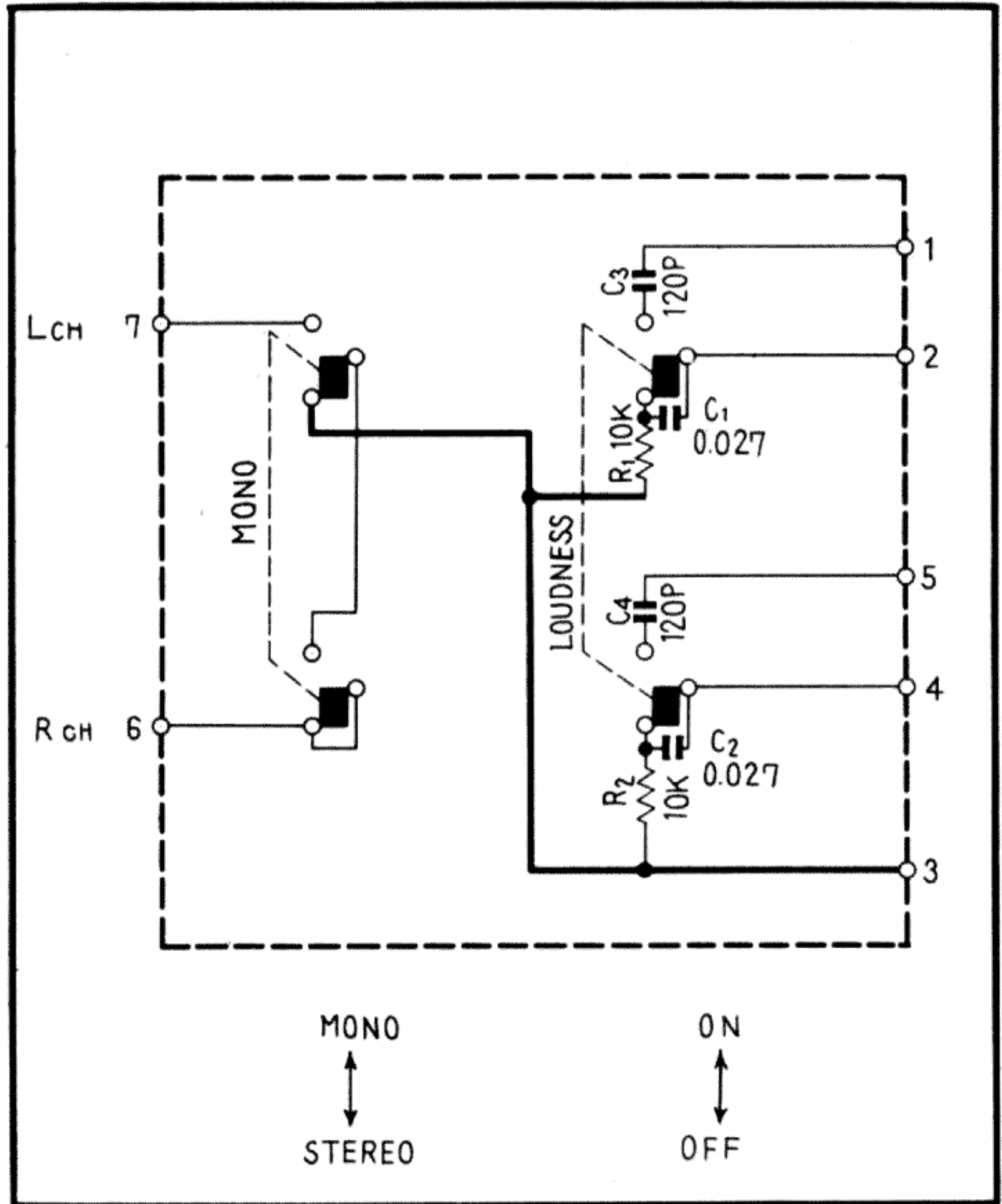

### Foil Side (AWS-065-0)

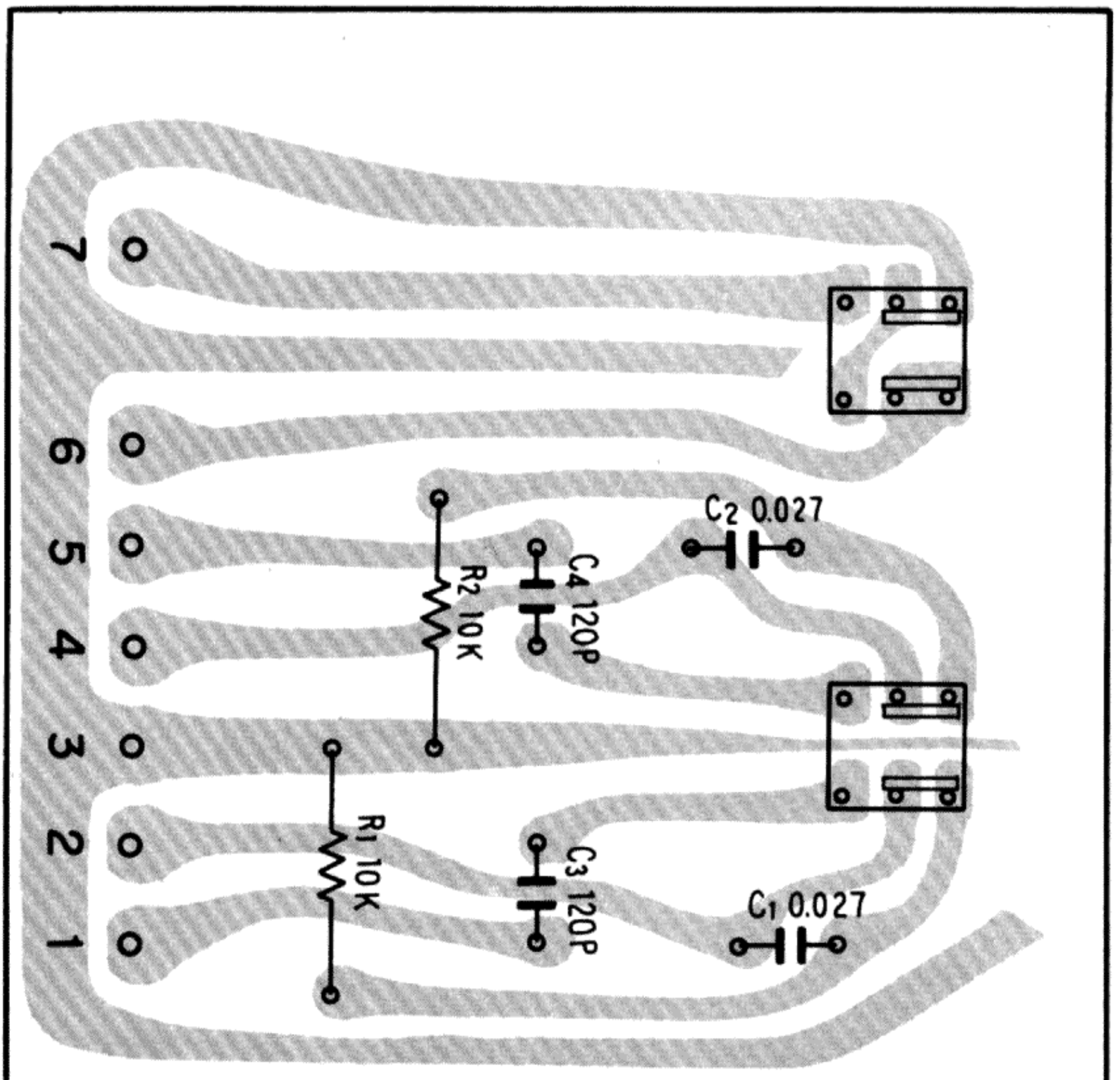

## Parts List of Switch Circuit Assembly (AWS-065-0)

### SWITCH

Symbol	Description	Part No.
S1	Push switch (mode, loudness)	ASG-063-0

### CAPACITORS AND RESISTORS

Symbol	Description	Part No.
C1	Mylar 0.027 50V	CQMA 273J 50
C2	Mylar 0.027 50V	CQMA 273J 50
C3	Ceramic 120p 50V	CCDSL 121K 50
C4	Ceramic 120p 50V	CCDSL 121K 50
R1	carbon film 10k	RD¼PS 103J
R2	carbon film 10k	RD¼PS 103J

### 13.12 SWITCH CIRCUIT ASSEMBLY (AWS-066-0)

Foil Side

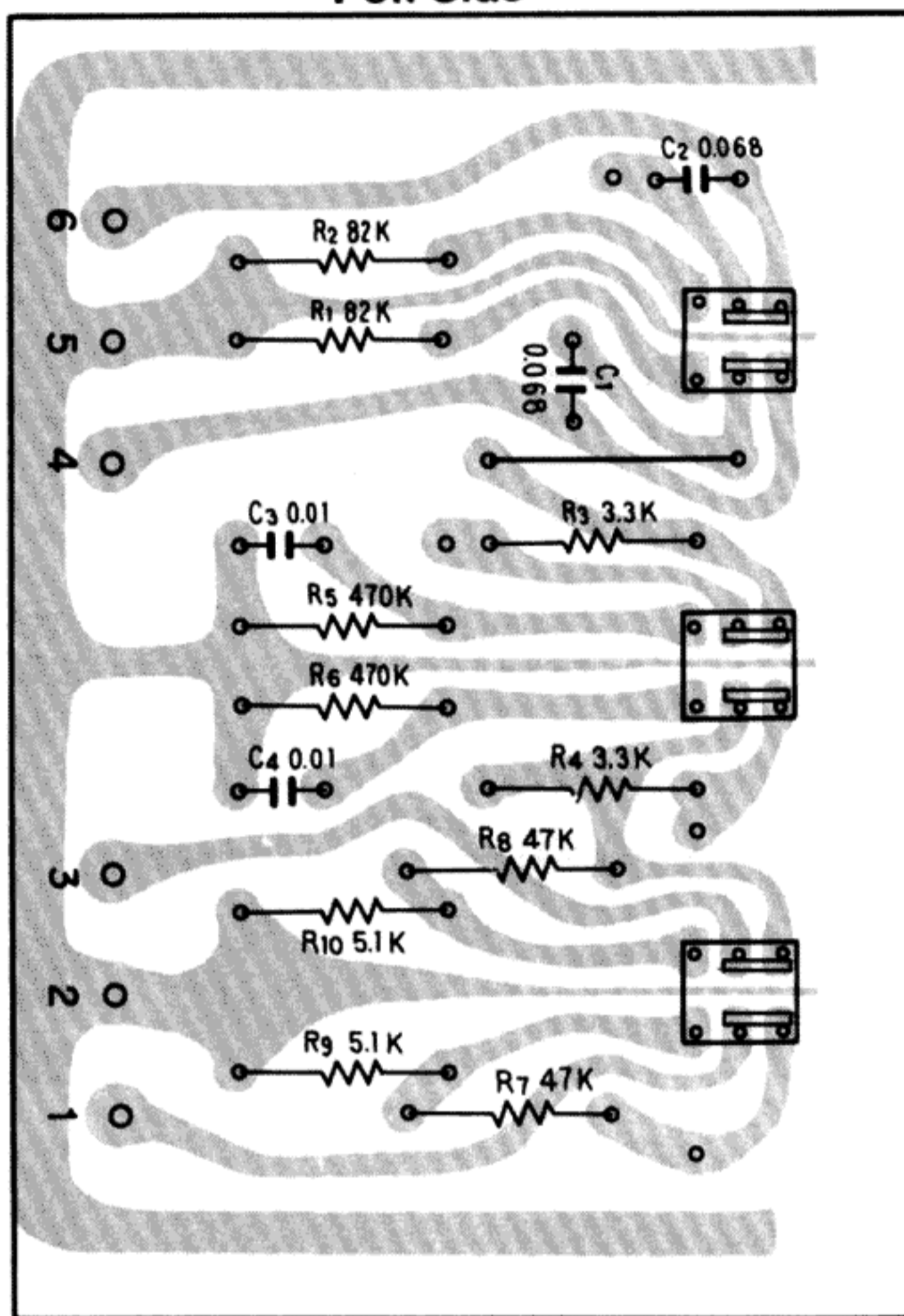
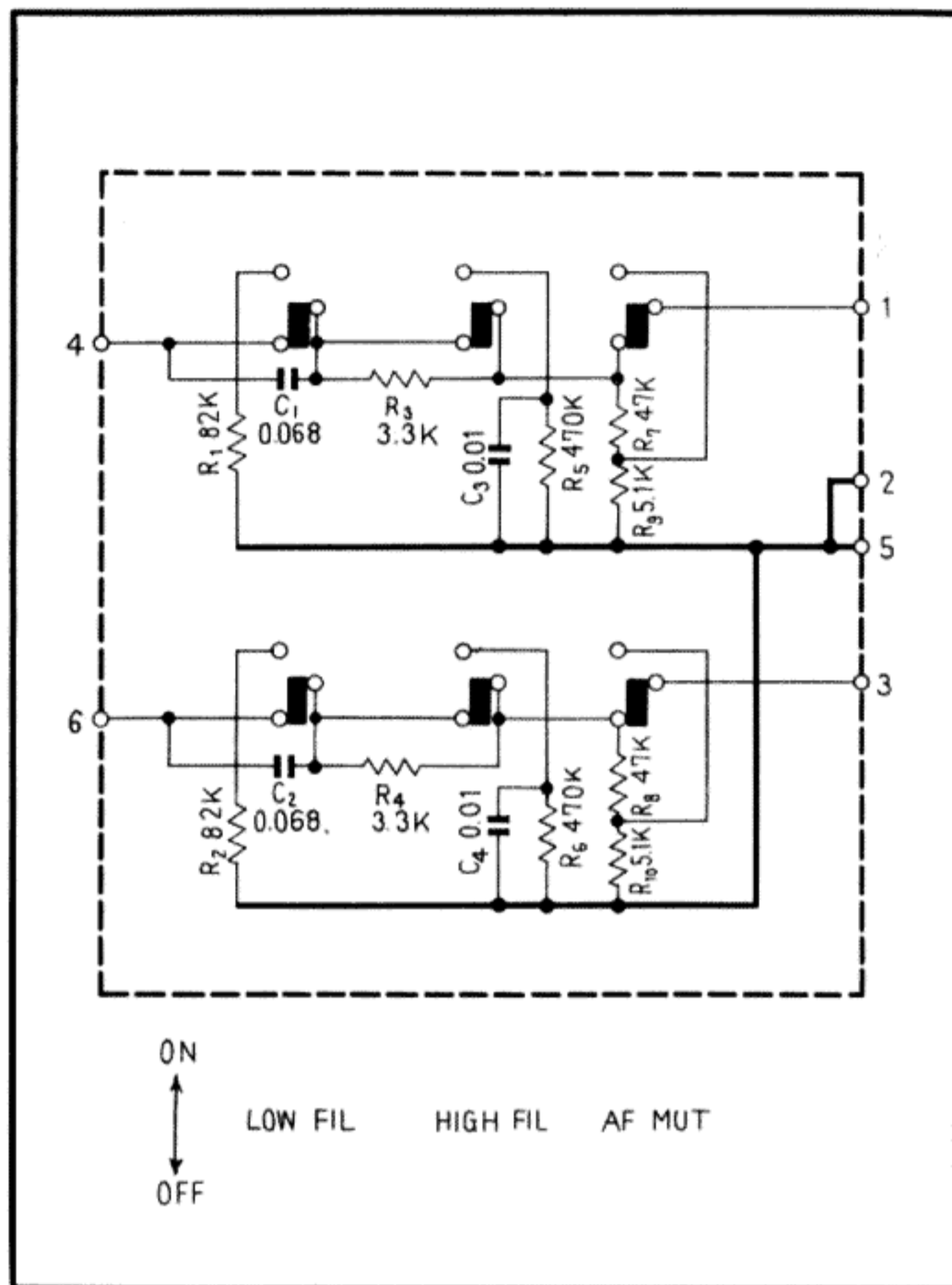

#### SWITCH

Symbol	Description	Part No.
S1	Push switch (filter, AF muting)	ASG-062-0

#### CAPACITORS

Symbol	Description	Part No.
C1	Mylar 0.068 50V	CQMA 683K 50
C2	Mylar 0.068 50V	CQMA 683K 50
C3	Mylar 0.01 50V	CQMA 103K 50
C4	Mylar 0.01 50V	CQMA 103K 50

#### RESISTORS

Symbol	Description	Part No.
R1	Carbon film 82k	RD¼PM 823J
R2	Carbon film 82k	RD¼PM 823J
R3	Carbon film 3.3k	RD¼PM 332J
R4	Carbon film 3.3k	RD¼PM 332J
R5	Carbon film 470k	RD¼PM 474J
R6	Carbon film 470k	RD¼PM 474J
R7	Carbon film 47k	RD¼PM 473J
R8	Carbon film 47k	RD¼PM 473J
R9	Carbon film 5.1k	RD¼PM 512J
R10	Carbon film 5.1k	RD¼PM 512J

## 12.13 SWITCH CIRCUIT ASSEMBLY (AWS-074-0)

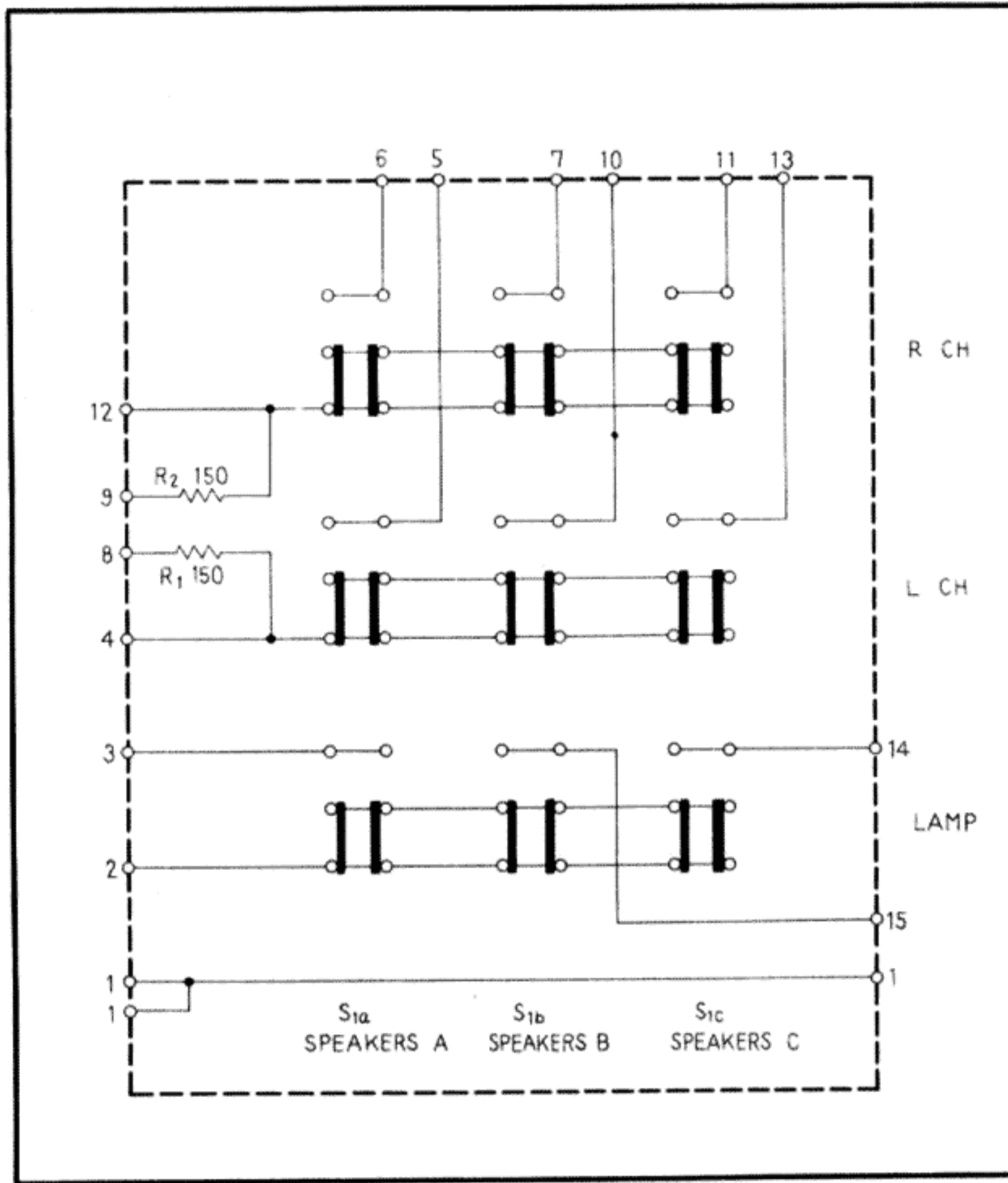

### Foil Side (AWS-074-0)

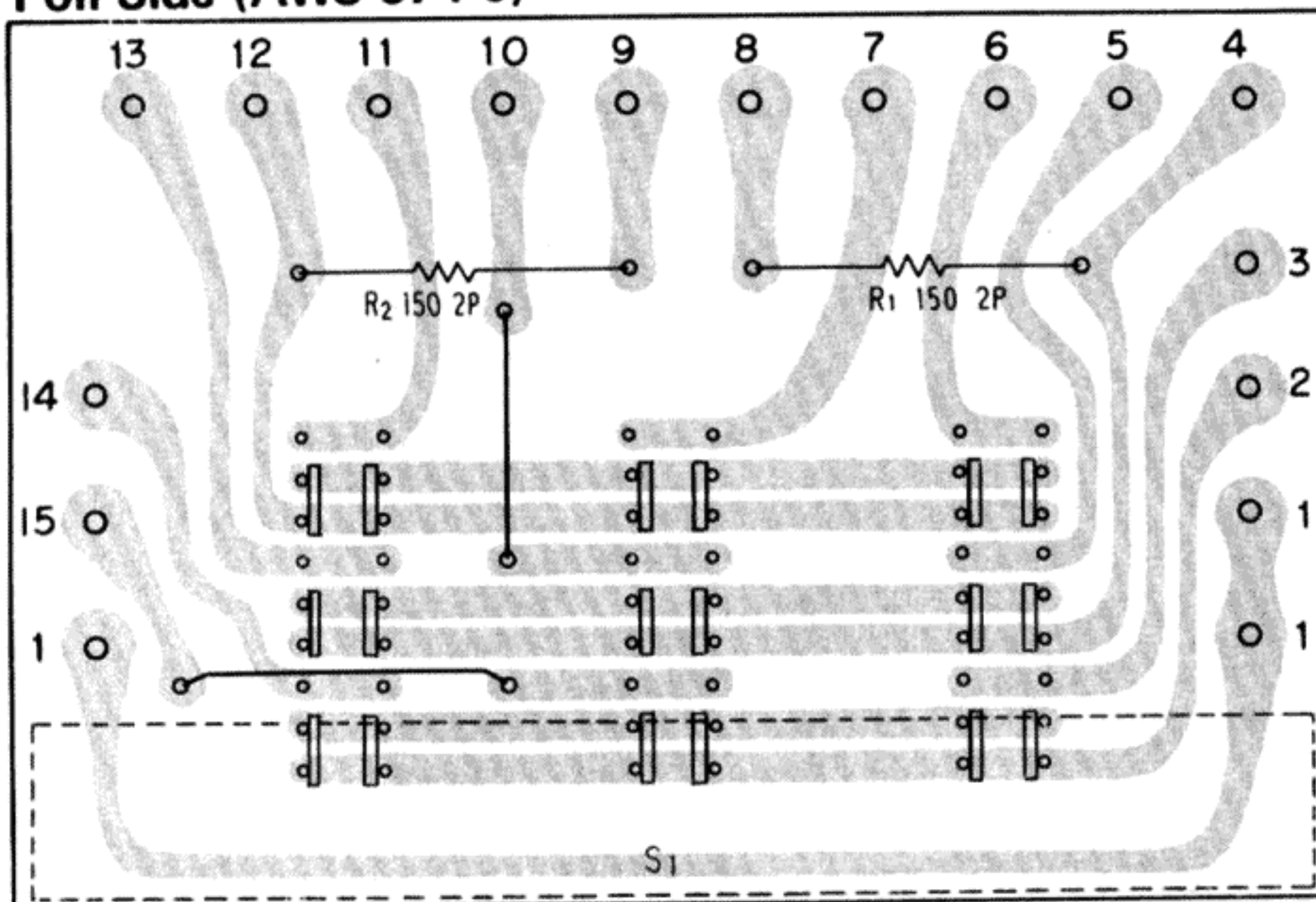

Symbol	Description	Part No.
S1	Push switch (speakers)	ASG-068-0
R1	Metal oxide 150 2W	RS2P 151K
R2	Metal oxide 150 2W	RS2P 151K

### 13.14 SWITCH CIRCUIT ASSEMBLY (AWS-075-0)

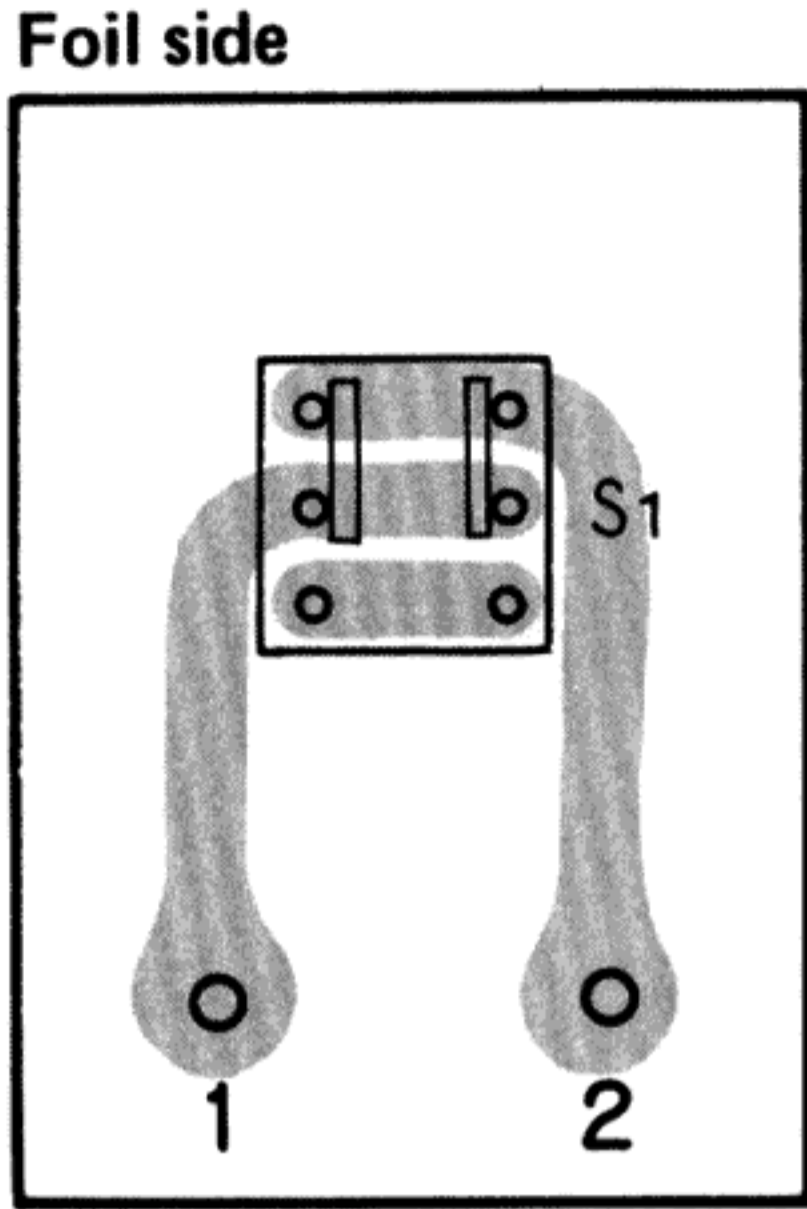

#### Parts List of Switch Circuit Assembly

Symbol	Description	Part No.	
S1	Push switch (FM muting)	ASG-058-0	

### 13.15 5P CONNECTOR ASSEMBLY (AWX-062-0)

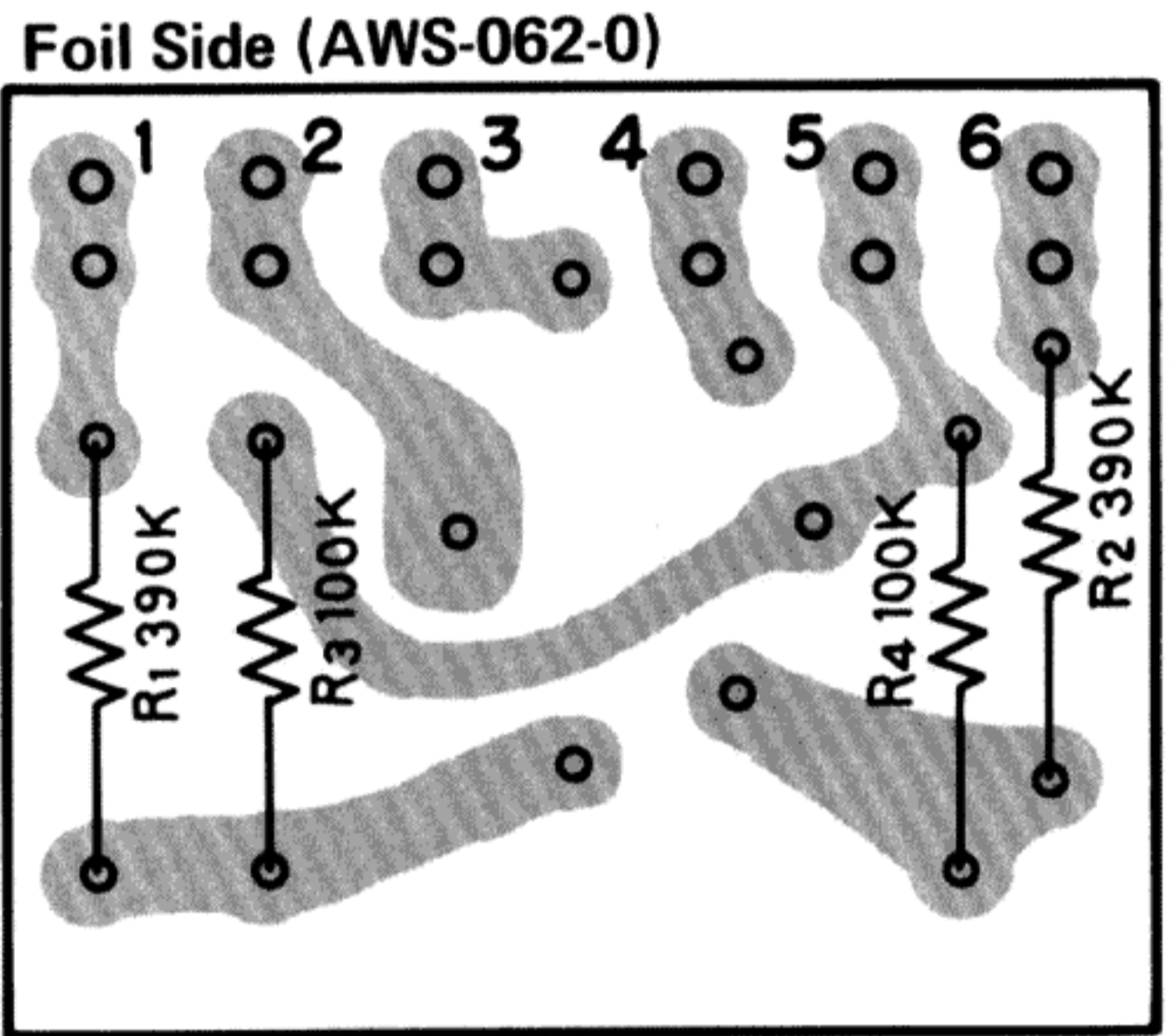
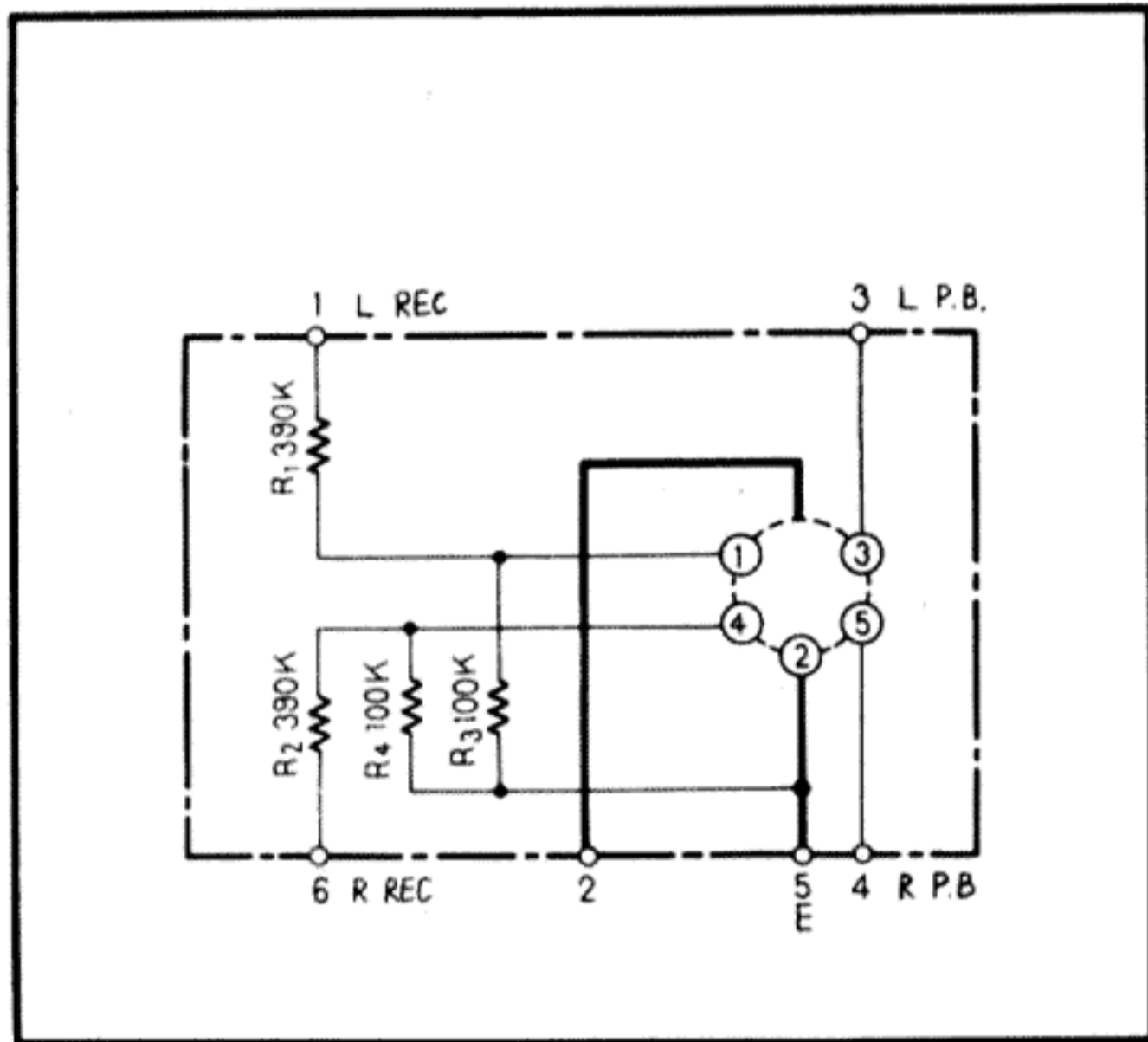

Symbol	Description	Part No.	
R1	Connector (DIN type 5P)	AKP-007-0	
R2	Carbon film 390k	RD¼PS 394J	
R3	Carbon film 100k	RD¼PS 104J	
R4	Carbon film 100k	RD¼PS 104J	

# 14. SCHEMATIC DIAGRAMS, P.C.BOARD PATTERNS AND PARTS LIST FOR 220V ONLY MODEL

## 14.1 Circuit Connection Diagram and Miscellaneous Parts



- CAPACITORS: IN  $\mu$ F UNLESS OTHERWISE NOTED p: pF
- RESISTORS: IN  $\Omega$ ,  $\frac{1}{4}$ W UNLESS OTHERWISE NOTED k: k $\Omega$ , M: M $\Omega$

## Miscellaneous Parts List

### CAPACITORS

Symbol	Description	Part No.
C1	Electrolytic 8,000 50V	ACH-015-0
C2	Electrolytic 8,000 50V	ACH-015-0
C3	Electrolytic 1,000 63V	ACH-001-C
C4	Ceramic 0.01 50V	CKDYF 103Z 50
C7	Ceramic 0.01 250V	ACG-001-0
C10	Ceramic 0.01 50V	CKDYF 103Z 50

### SWITCHES

Symbol	Description	Part No.
S1	Lever switch (Power)	ASK-068-0
S2	Relay	ASR-007-0

### OTHERS

Symbol	Description	Part No.
	Tuner assembly	AWE-041-A
	Equalizer amplifier assembly	AWF-011-0
	Microphone amplifier assembly	AWM-064-0
	Control amplifier assembly	AWG-029-0
	Power amplifier assembly	AWH-031-A
	Protection circuit assembly	AWM-025-C
	Power supply circuit assembly	AWR-064-0
	Switch & VR assembly	AWX-070-0
	Switch circuit assembly (function)	AWS-073-0
	Switch circuit assembly (FM muting)	AWS-075-0
	Switch circuit assembly (mode, loudness)	AWS-065-0
	Switch circuit assembly (filter, AF muting)	AWS-066-0
	Switch circuit assembly (speakers)	AWS-074-0
	Lamp load assembly	AWX-069-0
	5P connector assembly	AWX-062-0
	Wooden cabinet assembly	AMM-035-B
	Phono jack - C (6 jacks)	AKB-016-0
	Phono jack - A (4 jacks)	AKB-014-0
	Phono jack (1 jack)	AKB-019-0
	Antenna terminal board	AKA-002-0

Symbol	Description	Part No.	
	Binding post for ground Power transformer	AKE-012-A ATT-181-0	
	Ferrite loopstick antenna Balun	ATB-026-0 T22-025-A	
	Pilot lamp 8V, 0.3A (dial scale) Pilot lamp 8V, 0.3A (meter) Pilot lamp 8V, 50mA (position) Pilot lamp 8V, 50mA (position)	E22-032-0 AEL-015-0 AEL-022-0 AEL-024-0	
	Fuse 3.15A (protection) Fuse 1A (protection) Fuse 2A (protection) Pilot lamp 6V, 30mA (stereo indicator)	AEK-042-0 E21-031-0 AEK-017-0 AEL-014-0	
	Speaker output terminal Phone jack (Headphone) Jumper plug Fuse holder (protection) PL socket	AKE-014-0 K72-026-0 AKM-004-A K91-088-C AKK-002-0	
	Connector (AC power) FM antenna Operating instructions (English) Operating instructions (French/German) Packing case	AKP-008-0 ADH-002-0 ARB-101-0 ARD-067-0 AHD-213-A	
	Side pad (L) Side pad (R) Inside packing	AHA-066-A AHA-067-A AHC-014-A	

## 14.2 Power Supply Circuit Assembly (AWR-064-0)

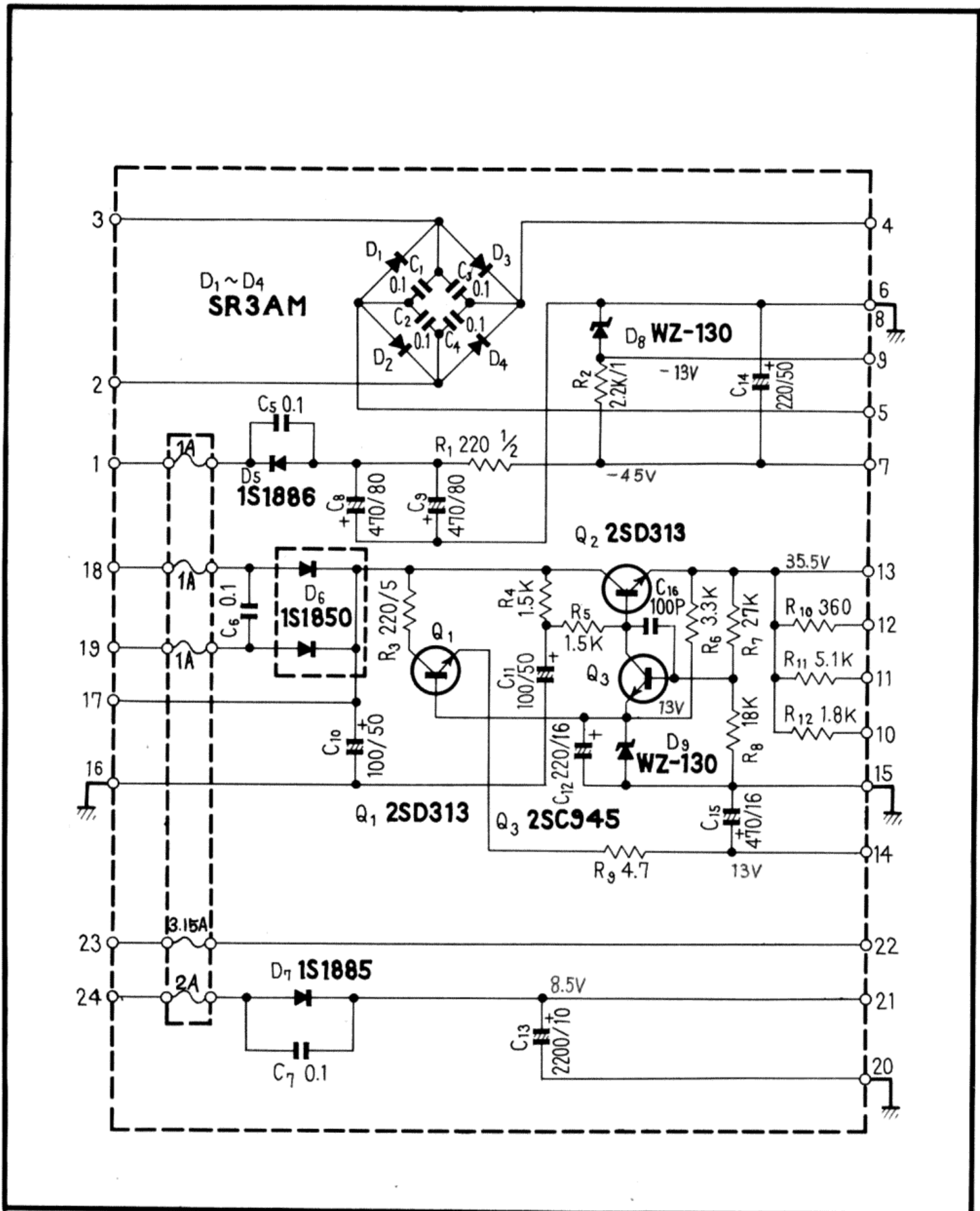

2SC945



2SD313

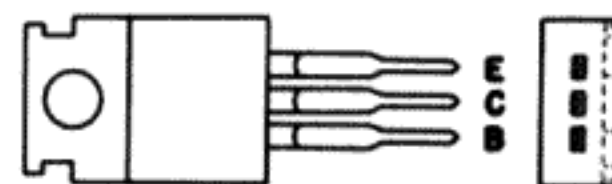

Foil Side (AWR-064-0)

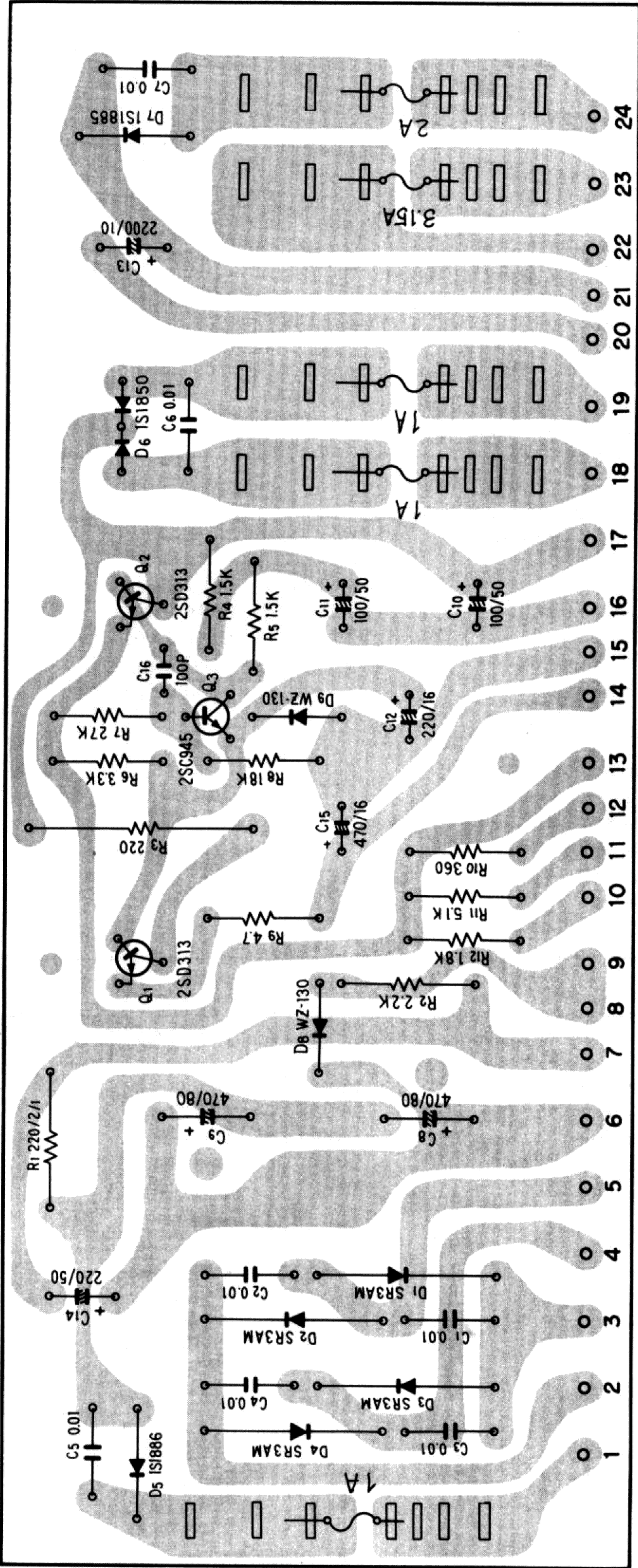

## Parts List of Power Supply Circuit Assembly (AWR-064-0)

### SEMICONDUCTORS

Symbol	Description	Part No.
Q1	Transistor 2SD313-E	
Q2	Transistor 2SD313P-E or D	
Q3	Transistor 2SC945-Q or R	
D1	Diode SR3AM-8	
D2	Diode SR3AM-8	
D3	Diode SR3AM-8	
D4	Diode SR3AM-8	
D5	Diode 1S1886	
D6	Diode 1S1850	
D7	Diode 1S1885	
D8	Zener diode WZ-130	
D9	Zener diode WZ-130	

### RESISTORS

Symbol	Description	Part No.
R1	Carbon film 220 ½W	RD¼PS 221J
R2	Metal oxide 2.2k 1W	RS1P 222K
R3	Wire wound 220 5W	RT5B 221K
R4	Carbon film 1.5k	RD¼PS 152J
R5	Carbon film 1.5k	RD¼PS 152J
R6	Carbon film 3.3k	RD¼PS 332J
R7	Carbon film 27k	RD¼PS 273J
R8	Carbon film 18k	RD¼PS 183J
R9	Carbon film 4.7	RD¼PS 4R7J
R10	Carbon film 360	RD¼PS 361J
R11	Carbon film 5.1k	RD¼PS 512J
R12	Carbon film 1.8k	RD¼PS 182J

### CAPACITORS

Symbol	Description	Part No.
C1	Ceramic 0.01 150V	ACG-004-0
C2	Ceramic 0.01 150V	ACG-004-0
C3	Ceramic 0.01 150V	ACG-004-0
C4	Ceramic 0.01 150V	ACG-004-0
C5	Ceramic 0.01 150V	ACG-004-0
C6	Ceramic 0.01 150V	ACG-004-0
C7	Ceramic 0.01 150V	ACG-004-0
C8	Electrolytic 470 80V	ACH-038-0
C9	Electrolytic 470 80V	ACH-038-0
C10	Electrolytic 100 50V	CEA 101P 50
C11	Electrolytic 100 50V	CEA 101P 50
C12	Electrolytic 220 16V	CEA 221P 16
C13	Electrolytic 2,200 10V	CEA 222P 10
C14	Electrolytic 220 50V	CEA 221P 50
C15	Electrolytic 470 16V	CEA 471P 16
C16	Ceramic 100p 50V	CCDSL 101K 50