

Service Manual

PIONEER
The Art of Entertainment

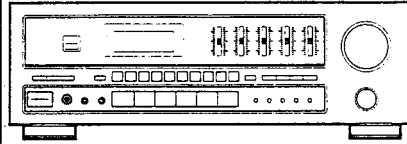

ORDER NO.
ARP2479

STEREO RECEIVER

SX-311R

SX-301

SX-251R

SX-201

SX-311R, SX-301, SX-251R AND SX-201 HAVE THE FOLLOWING :

Type	Model				Power Requirement	Remarks
	SX-311R	SX-301	SX-251R	SX-201		
KUC	○	○	○	○	AC120V only	
SD	○	—	—	○	AC110V, 120V-127V, 220V, 240V (switchable)	
KUC/CA	○	—	○	○	AC120V only	

- This manual is applicable to the following : SX-311R/KUC, SD and KUC/CA ; SX-301/KUC ; SX-251R/KUC and KUC/CA ; SX-201/KUC, SD and KUC/CA.
- For the following : SX-311R/SD and KUC/CA ; SX-301/KUC ; SX-251R/KUC and KUC/CA ; SX-201/KUC, SD and KUC/CA, refer to pages 33-41.
- KUC/CA type is identical to KUC type with French operating instruction. For all information except for the instruction, refer to KUC type.

CONTENTS

1. SAFETY INFORMATION	2	5. PCB PARTS LIST	27
2. SPECIFICATIONS	3	6. ADJUSTMENTS	31
3. EXPLODED VIEWS, PACKING AND PARTS LIST	4	7. FOR SX-311R/SD, KUC/CA, SX-301/KUC, SX-251R/KUC, KUC/CA, SX-201/KUC, SD AND KUC/CA TYPES	33
4. SCHEMATIC DIAGRAMS AND PCB CONNECTION DIAGRAMS	8	8. PANEL FACILITIES	42

PIONEER ELECTRONIC CORPORATION 4-1, Meguro 1-Chome, Meguro-ku, Tokyo 153, Japan
PIONEER ELECTRONICS SERVICE INC. P.O. Box 1760, Long Beach, California 90801 U.S.A.
PIONEER ELECTRONICS OF CANADA, INC. 300 Allstate Parkway Markham, Ontario L3R 0P2 Canada
PIONEER ELECTRONIC [EUROPE] N.V. Haven 1087 Keetberglaan 1, 9120 Melsele, Belgium
PIONEER ELECTRONICS AUSTRALIA PTY. LTD. 178-184 Boundary Road, Braeside, Victoria 3195, Australia TEL: [03] 580-9911
 © **PIONEER ELECTRONIC CORPORATION 1992**

DFS MAR. 1992 Printed in Japan

SX-311R/SX-301 SX-251R/SX-201

This service manual is intended for qualified service technicians; it is not meant for the casual do-it-yourselfer. Qualified technicians have the necessary test equipment and tools, and have been trained to properly and safely repair complex products such as those covered by this manual.

Improperly performed repairs can adversely affect the safety and reliability of the product and may void the warranty. If you are not qualified to perform the repair of this product properly and safely, you should not risk trying to do so and refer the repair to a qualified service technician.

WARNING

Lead in solder used in this product is listed by the California Health and Welfare agency as a known reproductive toxicant which may cause birth defects or other reproductive harm (California Health & Safety Code, Section 25249.5).

When servicing or handling circuit boards and other components which contain lead in solder, avoid unprotected skin contact with the solder. Also, when soldering do not inhale any smoke or fumes produced.

1. SAFETY INFORMATION

(FOR USA MODEL ONLY)

1. SAFETY PRECAUTIONS

The following check should be performed for the continued protection of the customer and service technician.

LEAKAGE CURRENT CHECK

Measure leakage current to a known earth ground (water pipe, conduit, etc.) by connecting a leakage current tester such as Simpson Model 229-2 or equivalent between the earth ground and all exposed metal parts of the appliance (input/output terminals, screwheads, metal overlays, control shaft, etc.). Plug the AC line cord of the appliance directly into a 120V AC 60Hz outlet and turn the AC power switch on. Any current measured must not exceed 0.5mA.

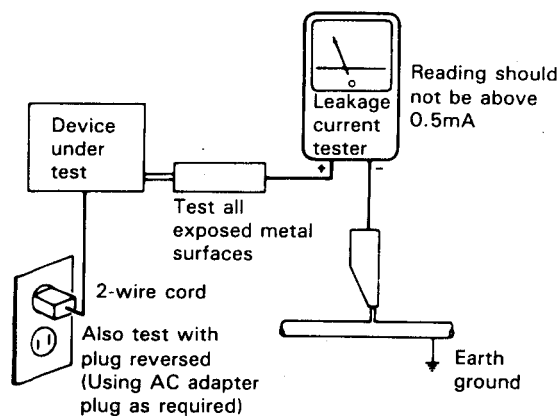

AC Leakage Test

ANY MEASUREMENTS NOT WITHIN THE LIMITS OUTLINED ABOVE ARE INDICATIVE OF A POTENTIAL SHOCK HAZARD AND MUST BE CORRECTED BEFORE RETURNING THE APPLIANCE TO THE CUSTOMER.

2. PRODUCT SAFETY NOTICE

Many electrical and mechanical parts in the appliance have special safety related characteristics. These are often not evident from visual inspection nor the protection afforded by them necessarily can be obtained by using replacement components rated for voltage, wattage, etc. Replacement parts which have these special safety characteristics are identified in this Service Manual.

Electrical components having such features are identified by marking with a Δ on the schematics and on the parts list in this Service Manual.

The use of a substitute replacement component which does not have the same safety characteristics as the PIONEER recommended replacement one, shown in the parts list in this Service Manual, may create shock, fire, or other hazards.

Product Safety is continuously under review and new instructions are issued from time to time. For the latest information, always consult the current PIONEER Service Manual. A subscription to, or additional copies of, PIONEER Service Manual may be obtained at a nominal charge from PIONEER.

2. SPECIFICATIONS

<SX-311R, SX-301>

Amplifier Section

Continuous Average Power Output is 70 watts* per channel, min., at 8 ohms from 20 Hertz to 20,000 Hertz with no more than 0.8% total harmonic distortion.**

Continuous Power Output (both channel driven)**	
20 Hz / 20 kHz, T.H.D. 0.8%, 8 Ω	70 W + 70 W
Dynamic power output (with EIA test signal)	
2/4/8 Ω	145 W/130 W/90 W
Input (Sensitivity/Impedance)	
PHONO	2.5 mV/47 kΩ
CD, VCR/LD, TAPE 1/DAT, TAPE 2	150 mV/22 kΩ
Phono Overload Level (T.H.D. 0.01%, 1 kHz)	
PHONO	130 mV
Output Level	
TAPE REC	150 mV/2.2 kΩ
Frequency Response	
PHONO (RIAA Equalization)	20 Hz to 20,000 Hz ±0.5 dB
CD, VCR/LD, TAPE 1/DAT, TAPE 2	10 Hz to 70,000 Hz ±0.5 dB
Signal-to-Noise Ratio (IHF, short circuited, A network)	
PHONO	72 dB
CD, VCR/LD, TAPE 1/DAT, TAPE 2	96 dB
Graphic Equalizer frequency band	100 Hz, 330 Hz, 1 kHz, 3.3 kHz, 10 kHz, ±8 dB

FM Tuner Section

Frequency range	87.5 MHz to 108 MHz
Usable Sensitivity	12.3 dBf, IHF (1.1 μV/75 Ω)
50 dB Quieting Sensitivity	
MONO	16.8 dBf (1.6 μV/75 Ω)
STEREO	38.6 dBf (19.5 μV/75 Ω)
Signal-to-Noise Ratio	
MONO	73 dB (at 85 dBf)
STEREO	70 dB (at 85 dBf)
Distortion	
STEREO	0.3% (1 kHz)
Alternate Channel Selectivity	50 dB (400 kHz)
Stereo Separation	35 dB (1 kHz)
Frequency Response	30 Hz to 15 kHz (±1 dB)
Antenna Input	300 Ω balanced, 75 Ω unbalanced

AM Tuner Section

Frequency range	
When 10 kHz step	530 kHz to 1,700 kHz
(SX-311R only)	
When 9 kHz step	531 kHz to 1,602 kHz
Sensitivity	
IHF, Loop antenna	350 μV/m
Selectivity	20 dB
Signal-to-Noise Ratio	50 dB
Antenna	AM Loop Antenna

Miscellaneous

Power Requirements	
U.S., Canadian models	AC 120 Volts, 60 Hz
(SX-311R only)	
Multi-voltage model	~AC 110 V/120 V - 127 V /220 V/240 V (switchable), 50/60 Hz
Power Consumption	
U.S., Canadian models	250 W (UL), 335 VA (CSA)
(SX-311R only)	
Multi-voltage model	410 W
AC Outlet	SWITCHED x 1 : 100W MAX
Dimensions	
SX-311R	420 (W) X 140 (H) X 289 (D) mm 16-9/16(W) X 5-1/2 (H) X 11-3/8(D) in
SX-301	420 (W) X 135 (H) X 289 (D) mm 16-9/16(W) X 5-5/16 (H) X 11-3/8(D) in
Weight (without package)	5.8 kg (12 lb 13 oz)

Furnished Parts

FM Antenna	1
AM Loop Antenna	1
Operating Instructions	1
(SX-311R only)	
Remote control unit	1
Dry cell battery (size "AAA" (R03/UM-4))	2

* Measured pursuant to the Federal Trade Commission's Trade Regulation rule on Power Output Claims for Amplifier.
** Measured By Audio Spectrum Analyzer.

NOTE:
Specifications and design subject to possible modification without notice due to improvements.

<SX-251R, SX-201>

Amplifier Section

Continuous Average Power Output is 50 watts* per channel, min., at 8 ohms from 40 Hertz to 20,000 Hertz with no more than 0.8% total harmonic distortion.**

Continuous Power Output (both channel driven)**	
40 Hz / 20 kHz, T.H.D. 0.8%, 8 Ω	50 W + 50 W
Dynamic power output (with EIA test signal)	
4/8 Ω	85 W/65 W
Input (Sensitivity/Impedance)	
PHONO	2.5 mV/47 kΩ
CD, VCR/LD, TAPE 1/DAT, TAPE 2	150 mV/22 kΩ
Phono Overload Level (T.H.D. 0.01%, 1 kHz)	
PHONO	130 mV
Output Level	
TAPE REC	150 mV/2.2 kΩ
Frequency Response	
PHONO (RIAA Equalization)	20 Hz to 20,000 Hz ±0.5 dB
CD, VCR/LD, TAPE 1/DAT, TAPE 2	10 Hz to 70,000 Hz ±0.5 dB
Signal-to-Noise Ratio (IHF, short circuited, A network)	
PHONO	72 dB
CD, VCR/LD, TAPE 1/DAT, TAPE 2	96 dB
Graphic Equalizer frequency band	100 Hz, 330 Hz, 1 kHz, 3.3 kHz, 10 kHz, ±8 dB

FM Tuner Section

Frequency range	87.5 MHz to 108 MHz
Usable Sensitivity	12.3 dBf, IHF (1.1 μV/75 Ω)
50 dB Quieting Sensitivity	
MONO	16.8 dBf (1.6 μV/75 Ω)
STEREO	38.6 dBf (19.5 μV/75 Ω)
Signal-to-Noise Ratio	
MONO	73 dB (at 85 dBf)
STEREO	70 dB (at 85 dBf)
Distortion	
STEREO	0.3% (1 kHz)
Alternate Channel Selectivity	50 dB (400 kHz)
Stereo Separation	35 dB (1 kHz)
Frequency Response	30 Hz to 15 kHz (±1 dB)
Antenna Input	300 Ω balanced, 75 Ω unbalanced

AM Tuner Section

Frequency range	
When 10 kHz step	530 kHz to 1,700 kHz
(SX-201 only)	
When 9 kHz step	531 kHz to 1,602 kHz
Sensitivity	
IHF, Loop antenna	350 μV/m
Selectivity	20 dB
Signal-to-Noise Ratio	50 dB
Antenna	AM Loop Antenna

Miscellaneous

Power Requirements	
U.S., Canadian models	AC 120 Volts, 60 Hz
(SX-201 only)	
Multi-voltage model	~AC 110 V/120 V - 127 V /220 V/240 V (switchable), 50/60 Hz
Power Consumption	
U.S., Canadian models	190 W (UL), 240 VA (CSA)
(SX-201 only)	
Multi-voltage model	290 W
AC Outlet	SWITCHED x 1 : 100W MAX
Dimensions	420 (W) X 135 (H) X 289 (D) mm 16-9/16(W) X 5-5/16 (H) X 11-3/8(D) in
Weight (without package)	5.3 kg (11 lb 11 oz)

Furnished Parts

FM Antenna	1
AM Loop Antenna	1
Operating Instructions	1
(SX-251R only)	
Remote control unit	1
Dry cell battery (size "AAA" (R03/UM-4))	2

* Measured pursuant to the Federal Trade Commission's Trade Regulation rule on Power Output Claims for Amplifier.
** Measured By Audio Spectrum Analyzer.

NOTE:
Specifications and design subject to possible modification without notice due to improvements.

3. EXPLODED VIEWS, PACKING AND PARTS LIST

NOTES:

- The parts with an encircled number are generally unavailable because they are not in our Master Spare Parts List.
- The \triangle mark found on some component parts indicates the importance of the safety factor of the part. Therefore, when replacing be sure to use parts of identical designation.
- Parts marked by "●" are not always kept in stock. Their delivery time may be longer than usual or they may be unavailable.

Parts list of Exterior and Packing

Mark	No.	Description	Parts No.	Mark	No.	Description	Parts No.
	1	ROTARY KNOB ASSY (VOLUME)	AAB1275		41	NUT	NK90FUC
	2	ROTARY KNOB S (BALANCE)	AAB1276	\triangle	42	FUSE (4A/125V, FU1)	AEK-125
	3	POWER KNOB	AAD1984		43	LOOP ANTENNA (L)	ATB1005
	4	BUTTON (SPEAKER)	AAD2211	\triangle	44	POWER TRANSISTOR (Q1)	2SC4689
	5	BUTTON A (PLS)	AAD2212	\triangle	45	POWER TRANSISTOR (Q2)	2SC4689
	6	BUTTON B (PLS)	AAD2213	\triangle	46	POWER TRANSISTOR (Q3)	2SA1804
	7	DISPLAY PANEL (PLS)	AAK2277	\triangle	47	POWER TRANSISTOR (Q4)	2SA1804
●	8	COMPLEX ASSEMBLY	AWZ4023	\triangle	48	POWER TRANSISTOR (Q5)	2SC4688
	9	SUB PANEL	AAP1232	\triangle	49	POWER TRANSFORMER (T1)	ATS1409
●	10	CONTROL ASSEMBLY	AWZ4019		50	TRANS ASSEMBLY	AWZ4016
	11	SCREW (STEEL)	ABA-297				
	12	SCREW	ABA-298				
	13	SCREW (STEEL)	ABA1009				
	14	SCREW (STEEL)	ABA1011				
	15	SCREW	ABA1018				
	16	SCREW	ABA1027				
	17	SCREW	ABA1054				
\triangle	18	AC POWER CORD	ADG1058				
	19	FM ANTENNA	ADH1008				
	20	PURSE LOCK	AEC1325				
\triangle	21	CORD STOPPER	AEP-113				
	22	BINDER	AEP-215				
	23	BATTERY (R03, AAA)	AEX-021				
	24	SIDE PAD (PS)	AHA1482				
	25	PACKING CASE	AHD2225				
	26	PACKING SHEET	AHG1016				
	27	FRONT PANEL (PLS)	AMB1950				
	28	PCB MOULD	AMR1525				
	29	INSULATOR ASSY	AMR2140				
	30	CHASSIS	ANA1163				
	31	REAR PANEL (MTL)	ANC1842				
	32	SP SWITCH ASSEMBLY	AWZ4020				
	33	BONNET CASE	ANE1334				
	34	HEAT SINK	ANH1364				
	35	OPERATING INSTRUCTIONS (ENGLISH)	ARB1357				
	36	VR ASSEMBLY	AWZ4024				
	37	REMOTE CONTROL UNIT (CU-SX042)	AXD1259				
	38	BATTERY COVER	AZA1297				
	39	SCREW	BCZ30P080FZK				
	40	SCREW	BPZ26P080FMC				

1

2

3

4

5

6

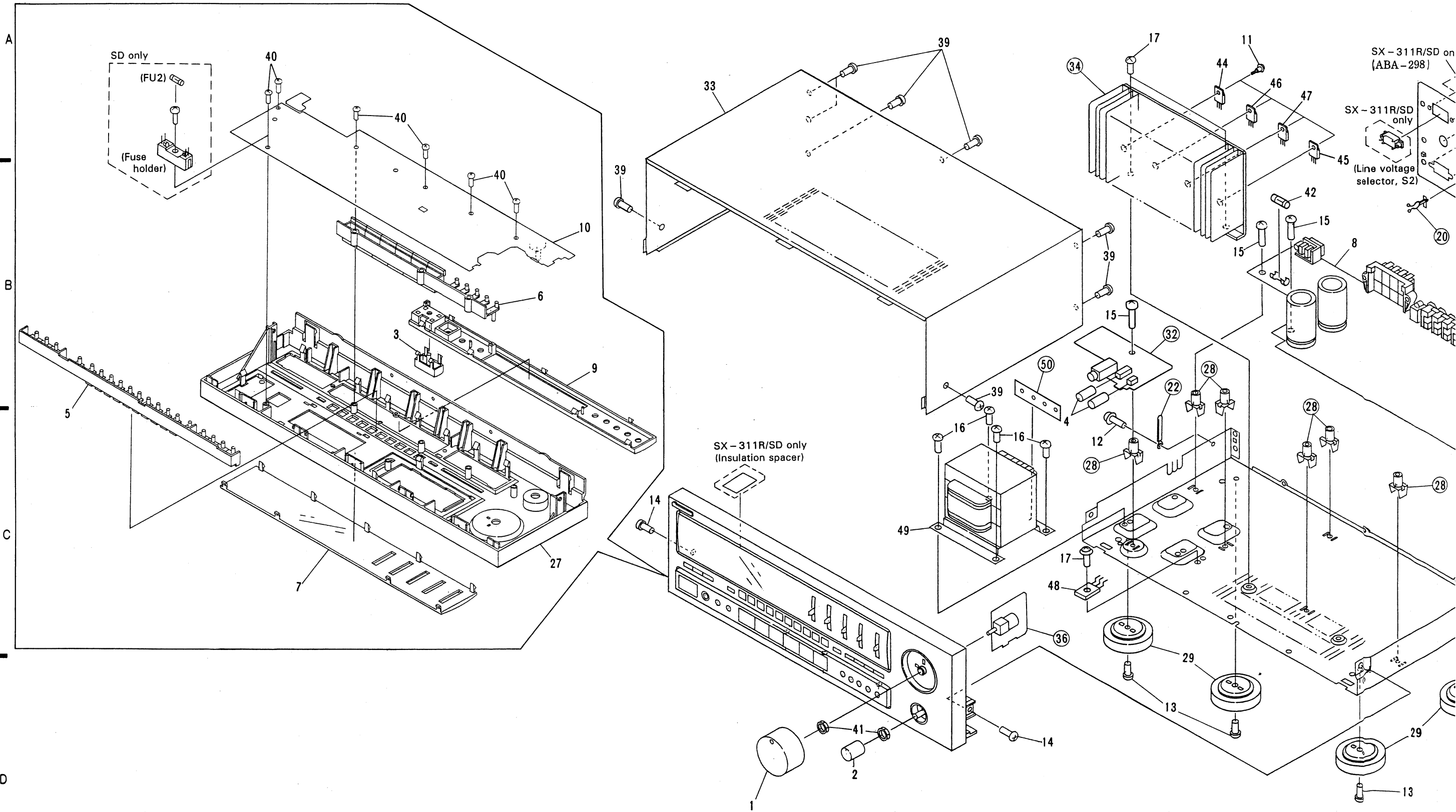

1

2

3

4

5

6

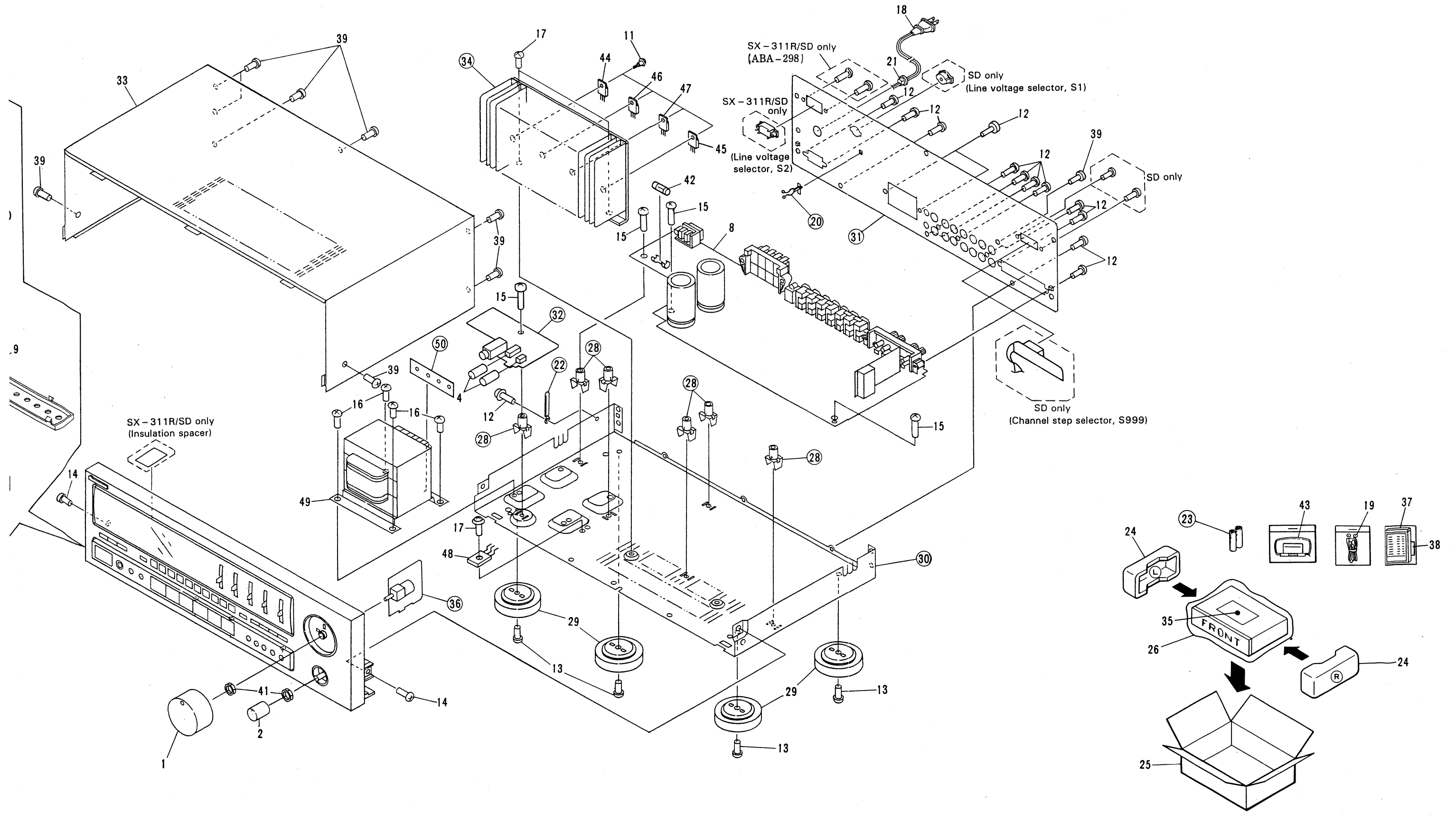

A

B

C

D

VI

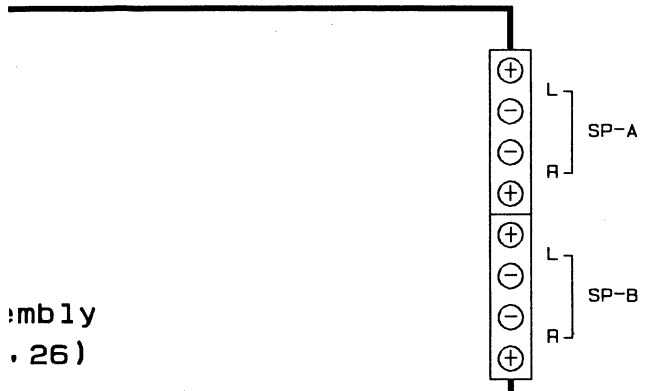

assembly
. 26)

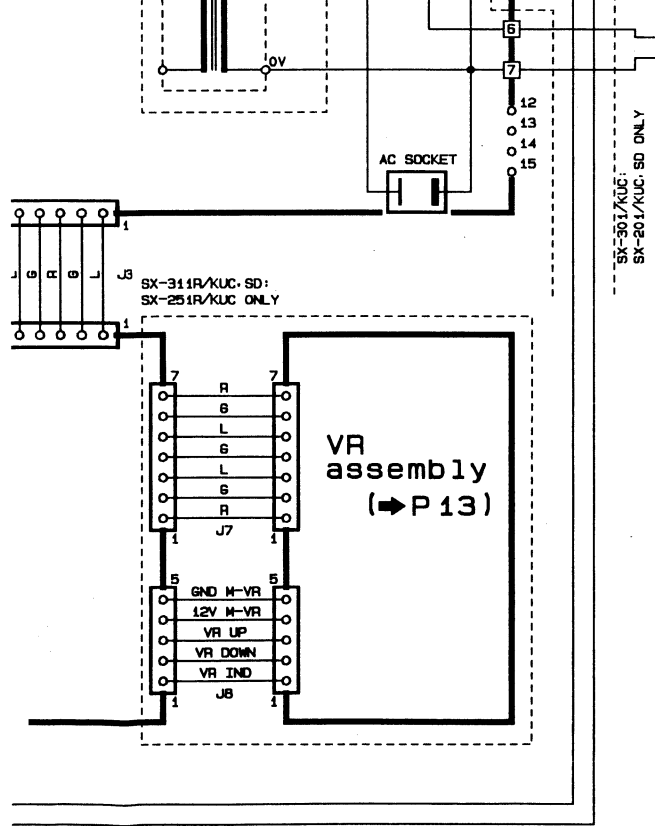
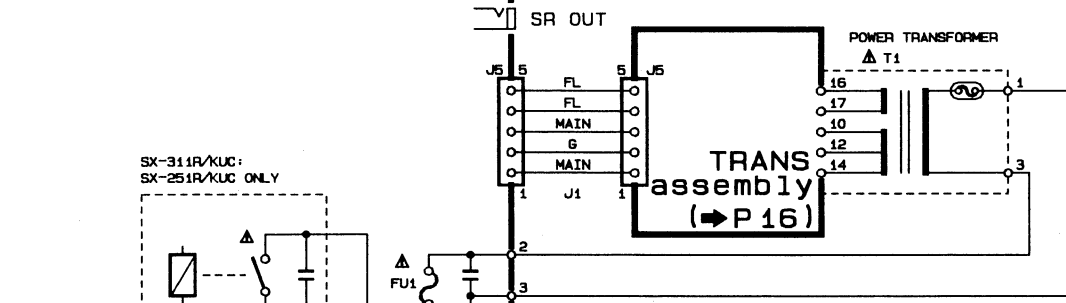

Contrast of Usage of Assemblies

Mark	Assembly Name	Model	SX-311R/ KUC	SX-311R/ SD	SX-301/ KUC	SX-251R/ KUC	SX-201/ KUC	SX-201/ SD
⊙	COMPLEX assembly	AWZ4023	AWZ4028	AWZ4022	AWZ4018	AWZ4014	AWZ4025	
⊙	CONTROL assembly	AWZ4019	AWZ4082	AWZ4015	AWZ4019	AWZ4015	AWZ4026	
	SP SWITCH assembly	N.S.P	N.S.P	N.S.P	N.S.P	N.S.P	N.S.P	
	9k/10k assembly	N/A	N.S.P	N/A	N/A	N/A	N.S.P	
	VR assembly	N.S.P	N.S.P	N/A	N.S.P	N/A	N/A	
	TRANS assembly	N.S.P	N.S.P	N.S.P	N.S.P	N.S.P	N.S.P	

NOTE : N.S.P ... Non supply part
N/A ... Not applicable

Contrast of Usage of Parts

Mark	Part No.	Model	SX-311R/ KUC	SX-311R/ SD	SX-301/ KUC	SX-251R/ KUC	SX-201/ KUC	SX-201/ SD
△	Q1, Q2	2SC4689	2SC4689	2SC4689	2SC4688	2SC4688	2SC4688	2SC4688
△	Q3, Q4	2SA1804	2SA1804	2SA1804	2SA1803	2SA1803	2SA1803	2SA1803
△	Q5	2SC4688	2SC4688	2SC4688	2SC4688	2SC4688	2SC4688	2SC4688
△	T1	ATS1409	ATS1411	ATS1409	ATS1408	ATS1408	ATS1410	ATS1410
△	FU1	AEK-125 (4A/125V)	AEK-122 (2A/125V)	AEK-125 (4A/125V)	AEK-124 (3.15A/125V)	AEK-124 (3.15A/125V)	AEK-121 (1.6A/125V)	AEK-121 (1.6A/125V)
△	FU2	N/A	AEK-122 (2A/125V)	N/A	N/A	N/A	AEK-121 (1.6A/125V)	AEK-121 (1.6A/125V)

NOTE : N/A ... Not applicable

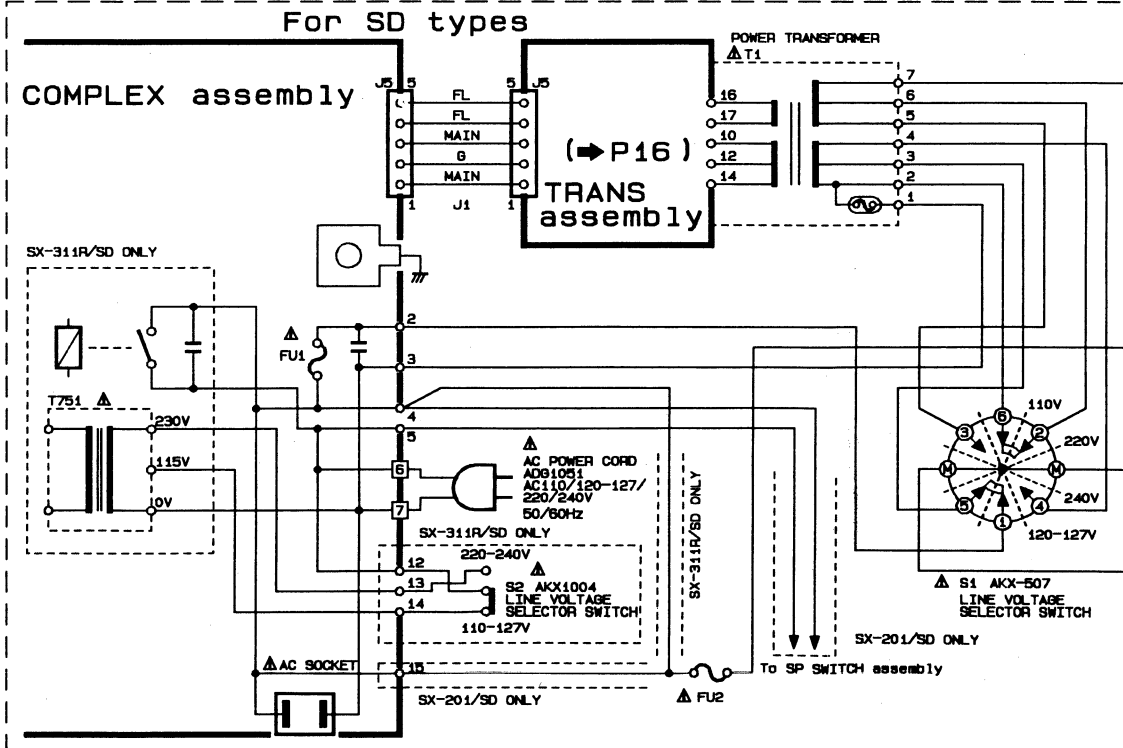

- RESISTORS:**
Indicated in Ω, ¼W, ½W, ±5% tolerance unless otherwise noted k : kΩ, M : MΩ, (F) : ±1%, (G) : ±2%, (K) : ±10% (M) : ±20% tolerance
- CAPACITORS:**
Indicated in capacity (μF)/voltage (V) unless otherwise noted p : pF
Indication without voltage is 50V except electrolytic capacitor.
- VOLTAGE, CURRENT:**
□ : Signal voltage at (W + W 8Ω)output (1kHz)
□ : DC voltage (V) at no input signal
Value in () is DC voltage at rated power.
↔ mA : DC current at no input signal
mV : Signal voltage at FM 1kHz ±75kHz DEV.

- OTHERS:**
➔ : Signal route.
⊙ : Adjusting point.
The △ mark found on some component parts indicates the importance of the safety factor of the part. Therefore, when replacing, be sure to use parts of identical designation.
* marked capacitors and resistors have parts numbers.
▼ (RED) : Measurement point
This is the basic schematic diagram, but the actual circuit may vary due to improvements in design.

- SWITCHES (The underline indicates the switch position)**
S1 VOLTAGE SELECTOR
110/120 - 127/220/240V
(SX-311R/SD; SX-201/SD ONLY)
S2 VOLTAGE SELECTOR
110 - 127V/220 - 240V
(SX-311R/SD ONLY)

- SP SWITCH assembly
S570 SP A/B
S1 POWER
(SX-301/KUC; SX-201/KUC, SD ONLY)

- 9k/10k assembly
S999 9k/10k
(SX-311R/SD; SX-201/SD ONLY)

- CONTROL assembly
- S801 FREQ UP
 - S802 FREQ DOWN
 - S803 2
 - S804 1
 - S805 FM
 - S806 AM
 - S807 MEMORY
 - S808 MEMORY SCAN
 - S809 POP
 - S810 ROCK
 - S811 OTHER
 - S812 HITS
 - S813 CD
 - S814 TUNER
 - S815 PHONO
 - S816 AUTO/MONO
 - S817 AUTO/MANUAL
 - S818 DIRECT ACCESS
 - S819 VCR/LD
 - S820 TAPE1/DAT
 - S821 TAPE2/MONITOR
 - S822 0
 - S823 9
 - S824 8
 - S825 RETURN
 - S826 7
 - S827 6
 - S828 5
 - S829 4
 - S830 3
 - S831 POWER
(SX-311R/KUC, SD; SX-251R/KUC ONLY)

4.2 CONTROL ASSEMBLY, 9k/10k ASSEMBLY AND VR ASSEMBLY

CONTROL ASSEMBLY (AWZ4019 : SX - 311R/KUC and SX - 251R/KUC)
 (AWZ4082 : SX - 311R/SD)
 (AWZ4015 : SX - 301/KUC and SX - 201/KUC)
 (AWZ4026 : SX - 201/SD)

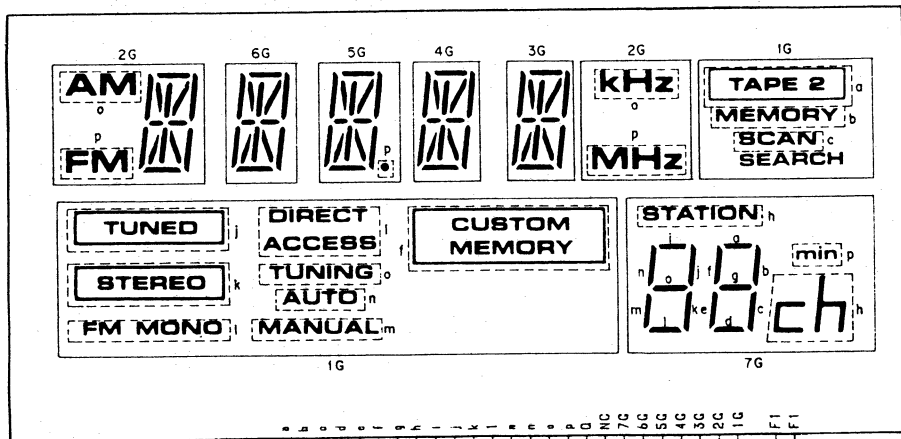

Q804, 805 : STANDBY INDI. DRIVER
 SX - 311R/SD ONLY

Q802 : BUFFER
 Q803 : INVERTER

SX - 311R/KUC, SD
 SX - 251R/KUC ONLY

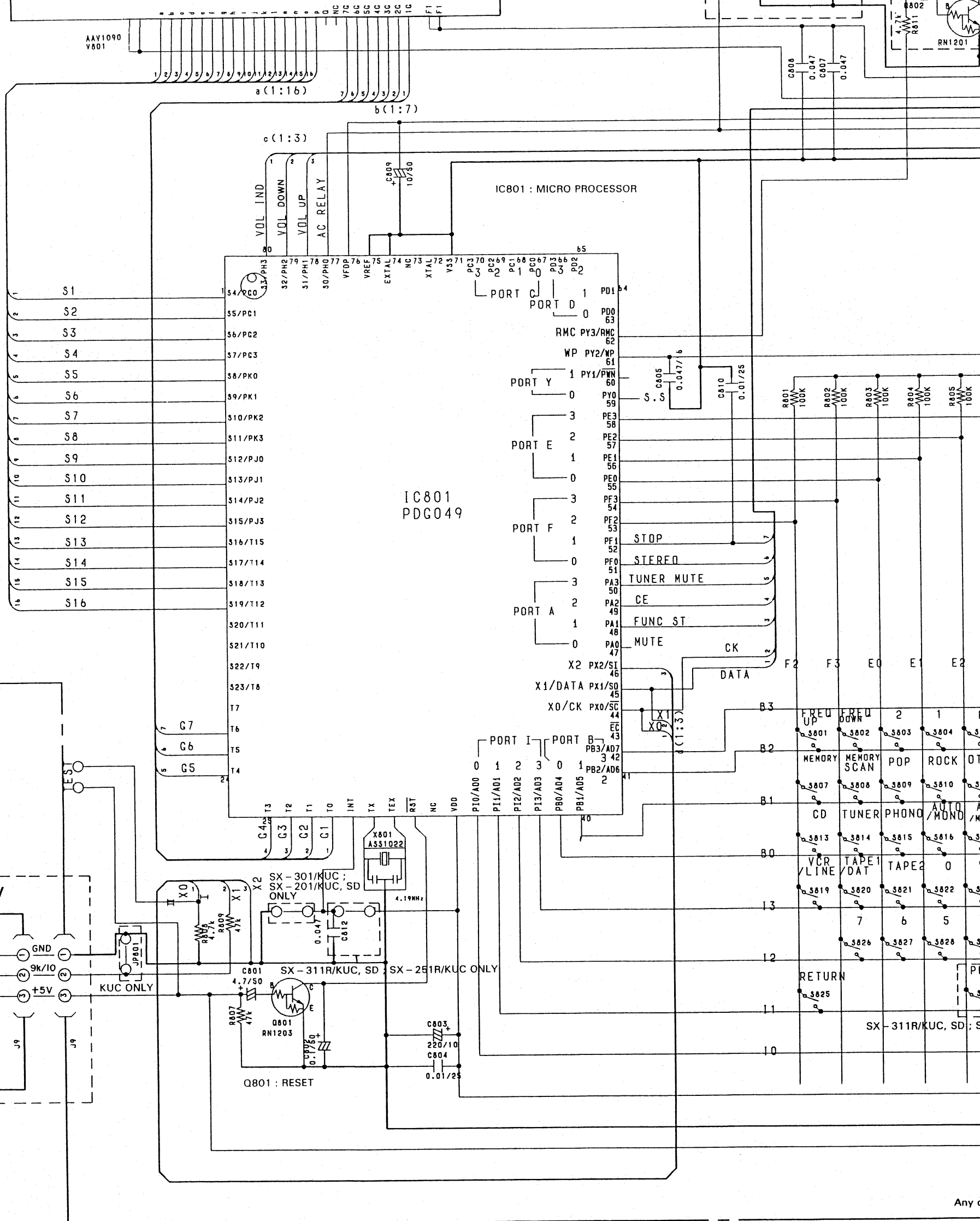

A

B

C

D

E

F

To C

Any c

and SX - 251R/KUC)

and SX - 201/KUC)

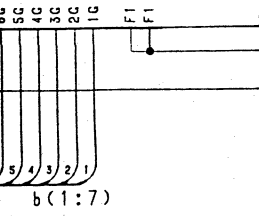
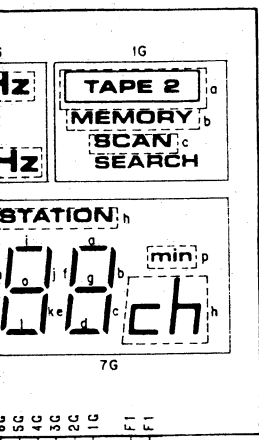

IC801 : MICRO PROCESSOR

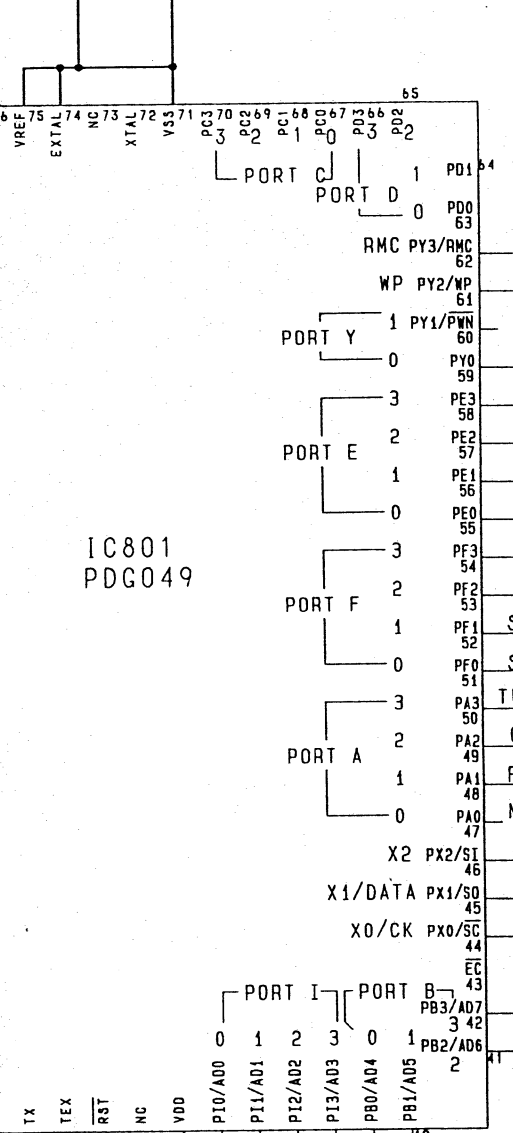

IC801 PDG049

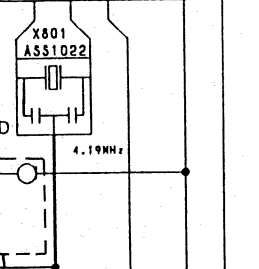

C, SD ; SX - 251R/KUC ONLY

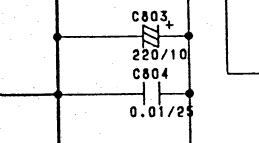

Q804, 805 : STANDBY INDI. DRIVER
SX - 311R/SD ONLY

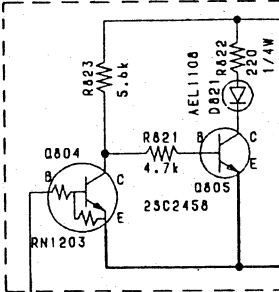

Q802 : BUFFER
Q803 : INVERTER

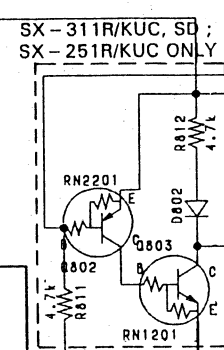

To COMPLEX assembly (1/2) J4 (P16)

SX - 311R/KUC, SD ;
SX - 251R/KUC
ONLY

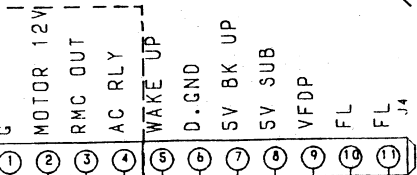

SX - 311R/KUC, SD ;
SX - 251R/KUC ONLY

To COMPLEX assembly (1/2)

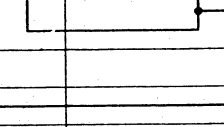
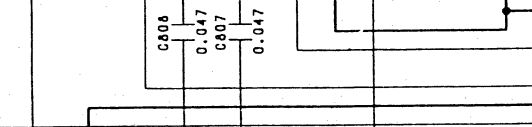
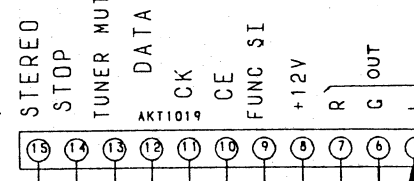

SX - 311R/KUC, SD ;
SX - 251R/KUC ONLY

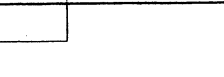
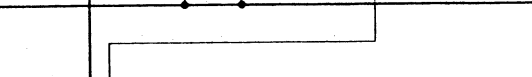

SX - 311R/KUC, SD ;
SX - 251R/KUC ONLY



SX - 311R/KUC, SD ;
SX - 251R/KUC ONLY

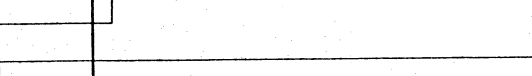

SX - 311R/KUC, SD ;
SX - 251R/KUC ONLY

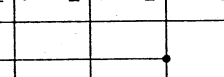
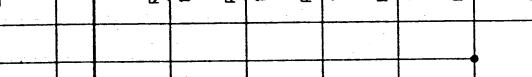

SX - 311R/KUC, SD ;
SX - 251R/KUC ONLY

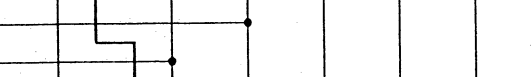

SX - 311R/KUC, SD ;
SX - 251R/KUC ONLY

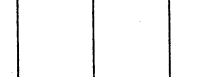
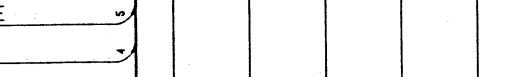

SX - 311R/KUC, SD ;
SX - 251R/KUC ONLY

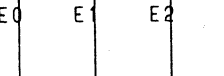
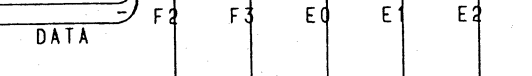

SX - 311R/KUC, SD ;
SX - 251R/KUC ONLY

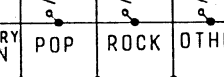

SX - 311R/KUC, SD ;
SX - 251R/KUC ONLY

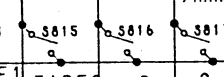
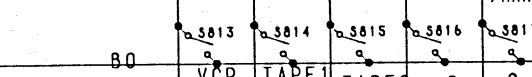

SX - 311R/KUC, SD ;
SX - 251R/KUC ONLY

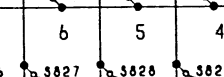
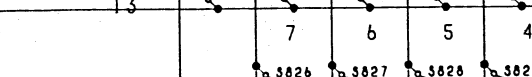

SX - 311R/KUC, SD ;
SX - 251R/KUC ONLY

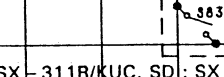
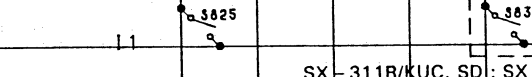

SX - 311R/KUC, SD ;
SX - 251R/KUC ONLY

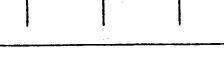
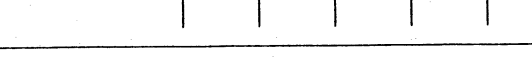

SX - 311R/KUC, SD ;
SX - 251R/KUC ONLY



SX - 311R/KUC, SD ;
SX - 251R/KUC ONLY



SX - 311R/KUC, SD ;
SX - 251R/KUC ONLY

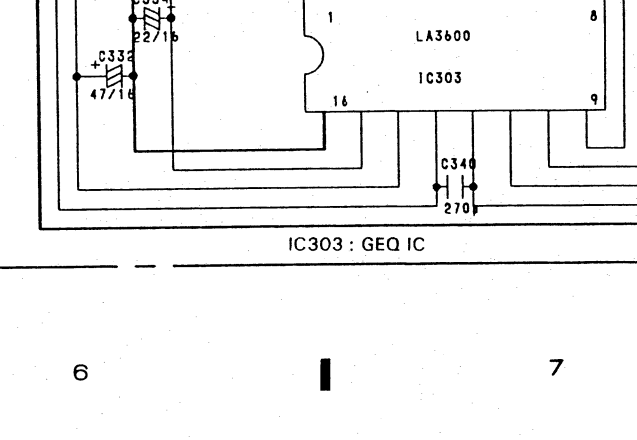
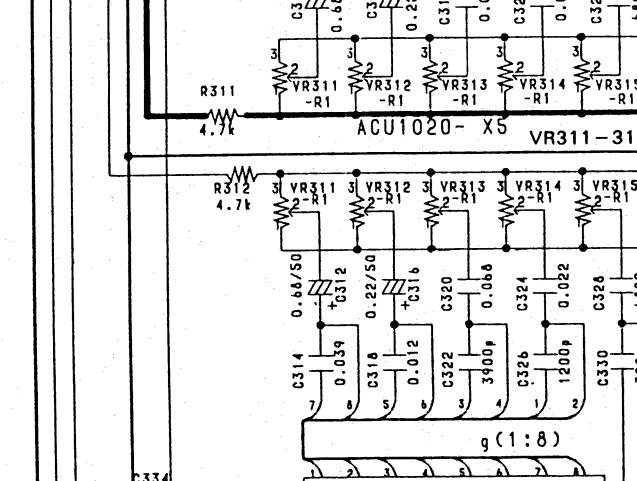
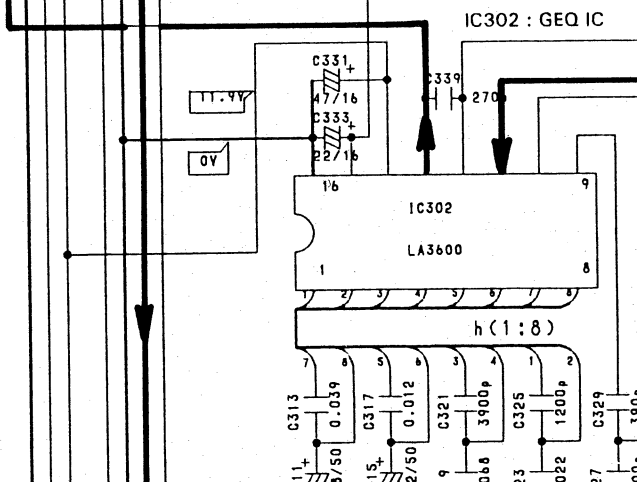
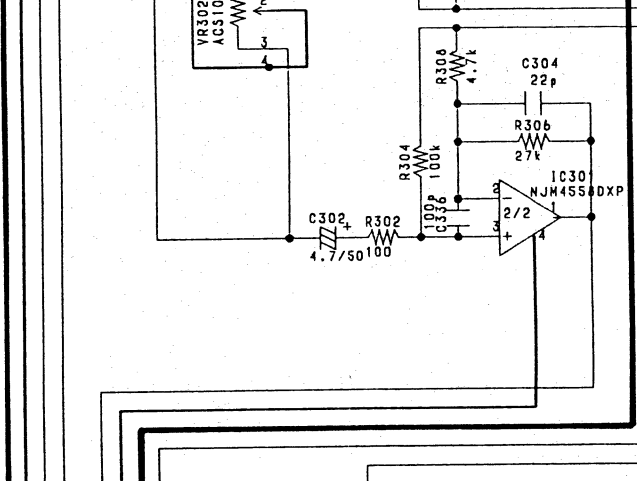
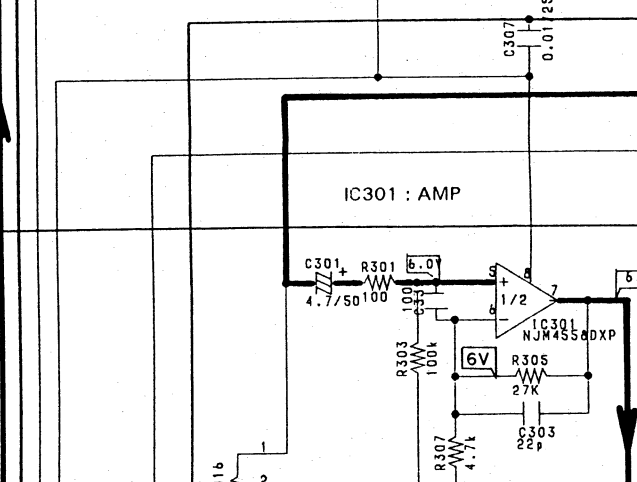
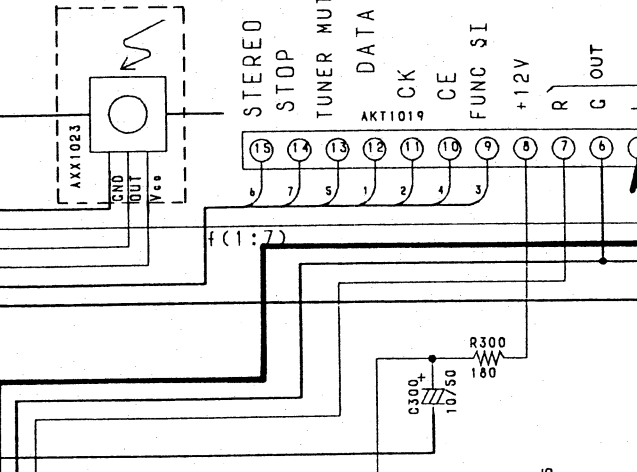

Any diode without part number indicates HSS104 - 02.

IC303 : GEQ IC

COMPLEX assembly (1/2) J4 (→ P16)

To COMPLEX assembly (1/2) J3 (→ P15)

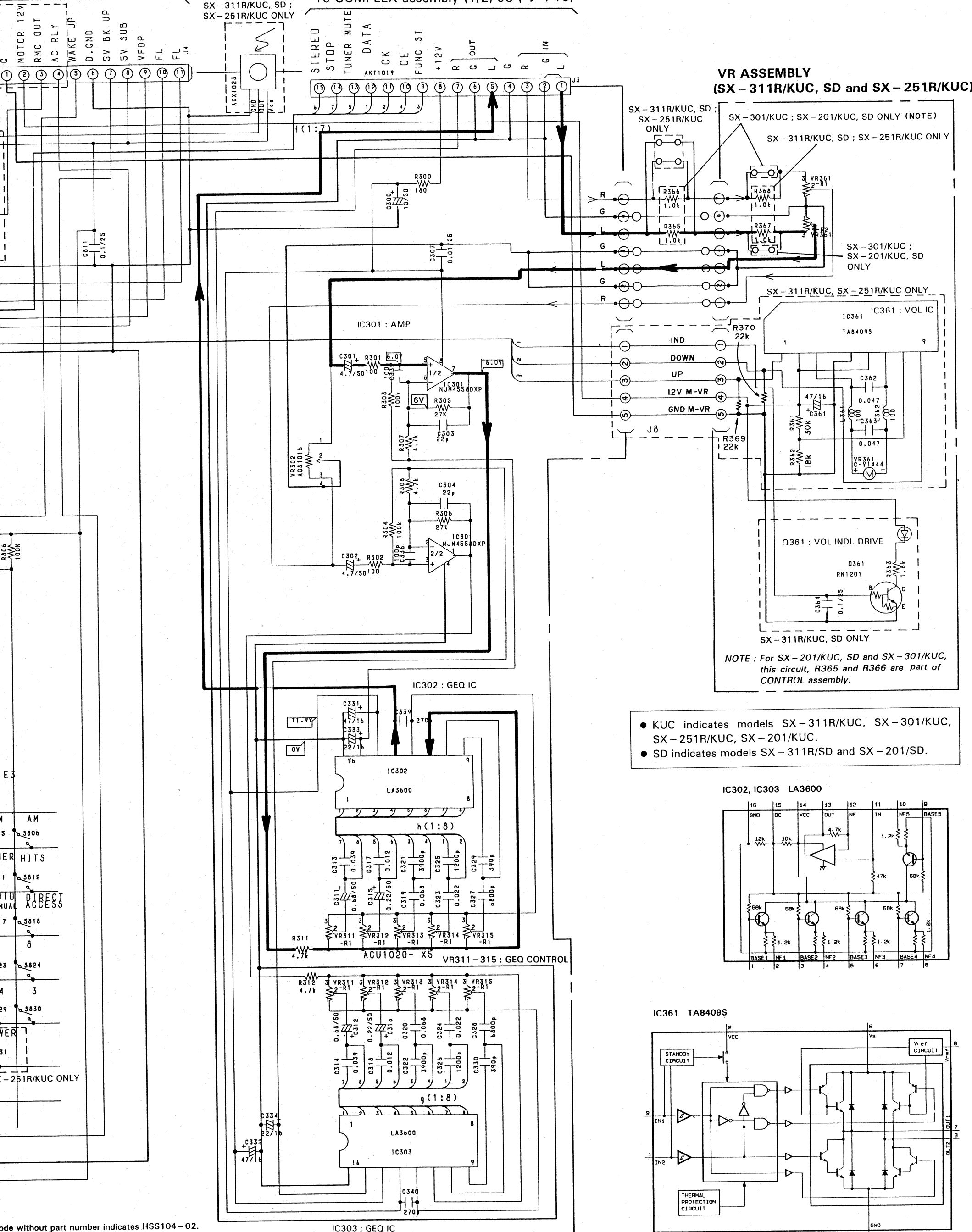

VR ASSEMBLY (SX-311R/KUC, SD and SX-251R/KUC)

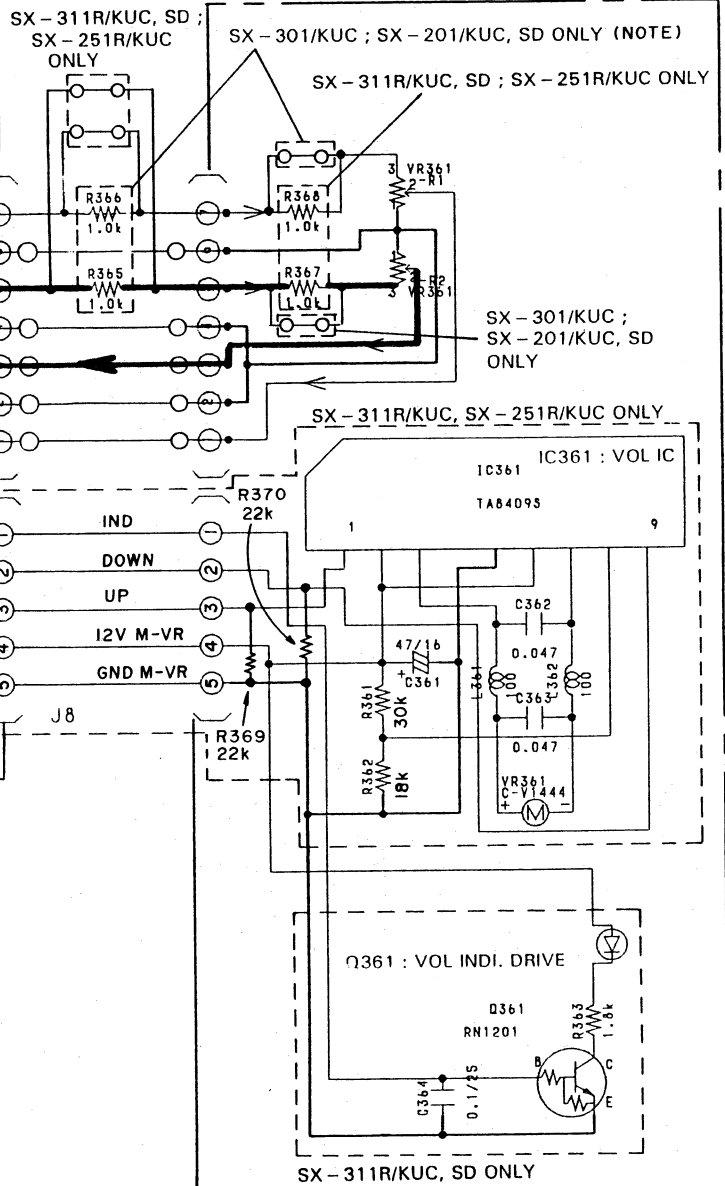

- KUC indicates models SX-311R/KUC, SX-301/KUC, SX-251R/KUC, SX-201/KUC.
- SD indicates models SX-311R/SD and SX-201/SD.

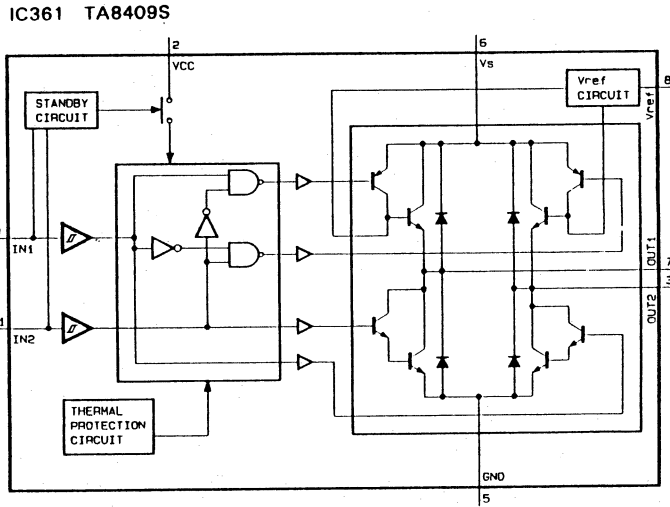
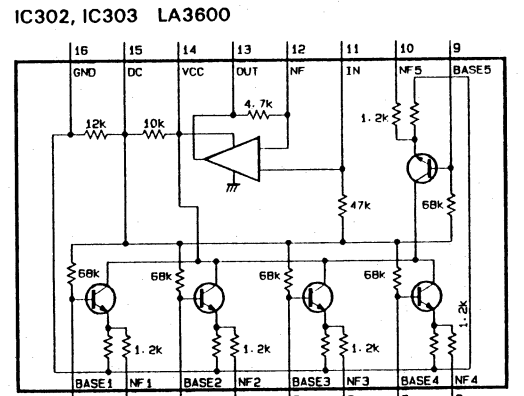

code without part number indicates HSS104-02.

**COMPLEX ASSEMBLY (1/2)(AWZ4023 : SX-311R/KUC)
 (AWZ4028 : SX-311R/SD)
 (AWZ4022 : SX-301/KUC)
 (AWZ4018 : SX-251R/KUC)
 (AWZ4014 : SX-201/KUC)
 (AWZ4025 : SX-201/SD)**

● Parts marked with * have the following variations :

Mark	Part No.	Model	SX-311R/ KUC	SX-311R/ SD	SX-301/ KUC	SX-251R/ KUC	SX-201/ KUC	SX-201/ SD
	Q551, Q552	2SC3298	2SC3298	2SC3298	2SC2235	2SC2235	2SC2235	2SC2235
	Q553, Q554	2SA1306	2SA1306	2SA1306	2SA965	2SA965	2SA965	2SA965
	C701, C702	ACH1044	ACH1044	ACH1044	ACH1145	ACH1145	ACH1145	ACH1145
	R521, R522	4.3kΩ	4.3kΩ	4.3kΩ	5.6kΩ	5.6kΩ	5.6kΩ	5.6kΩ
	R608	3.3kΩ	3.3kΩ	3.3kΩ	910Ω	910Ω	910Ω	910Ω
	R705	1.8kΩ	1.8kΩ	1.8kΩ	1.2kΩ	1.2kΩ	1.2kΩ	1.2kΩ
	R721, R722	8.2kΩ	8.2kΩ	8.2kΩ	6.8kΩ	6.8kΩ	6.8kΩ	6.8kΩ
	R723	10kΩ	10kΩ	10kΩ	6.8kΩ	6.8kΩ	6.8kΩ	6.8kΩ

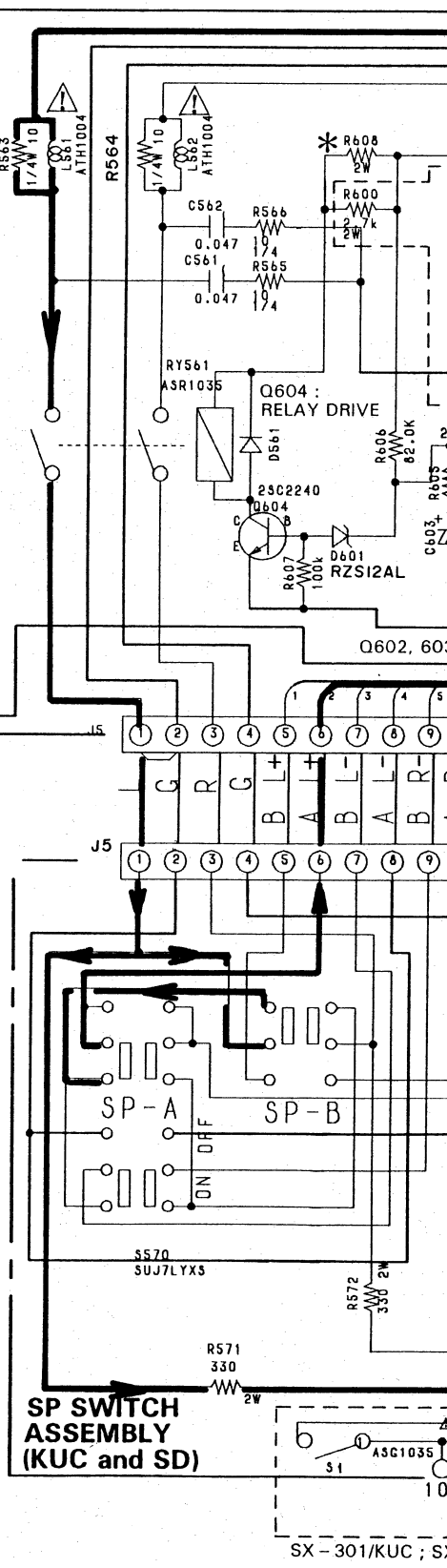
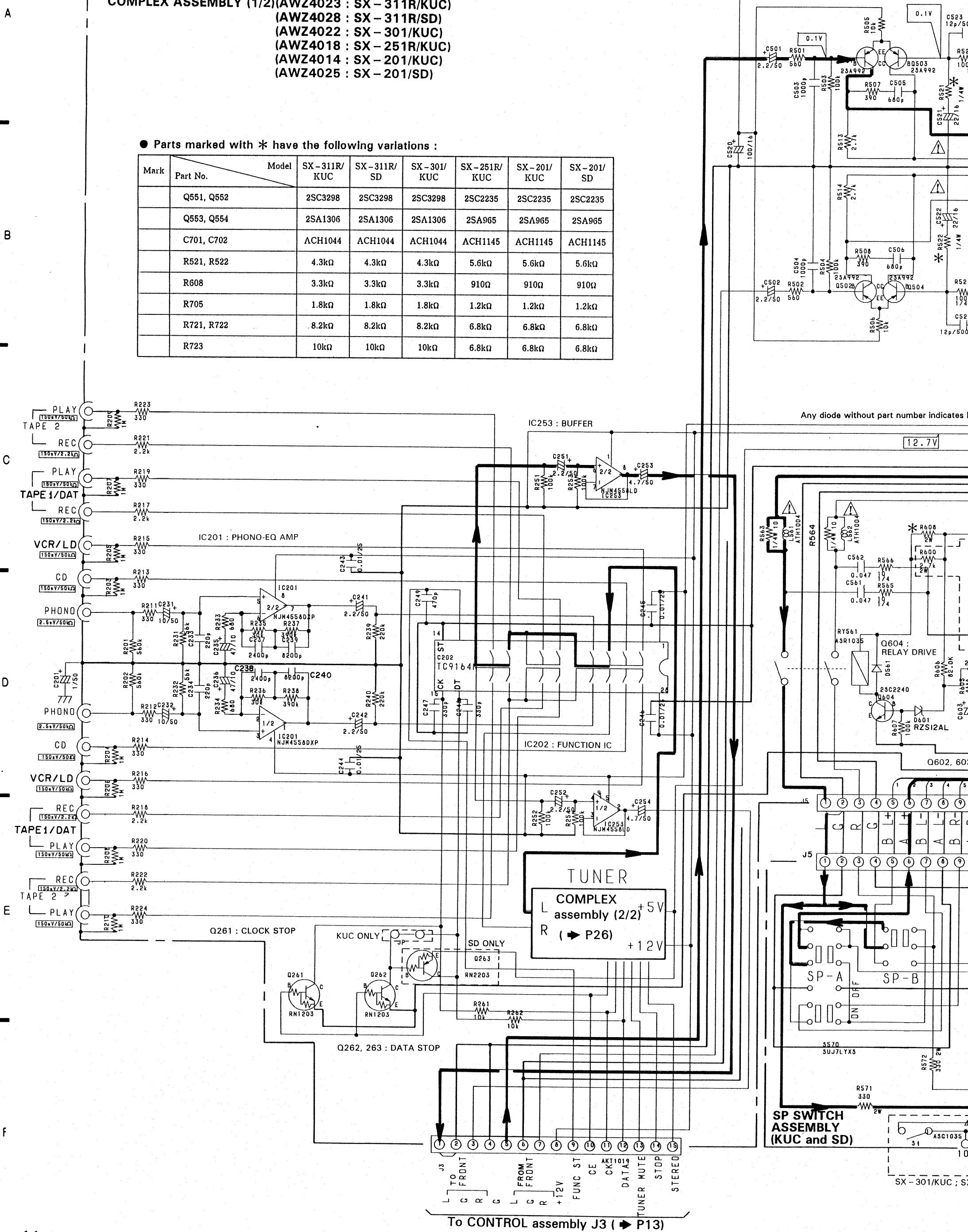

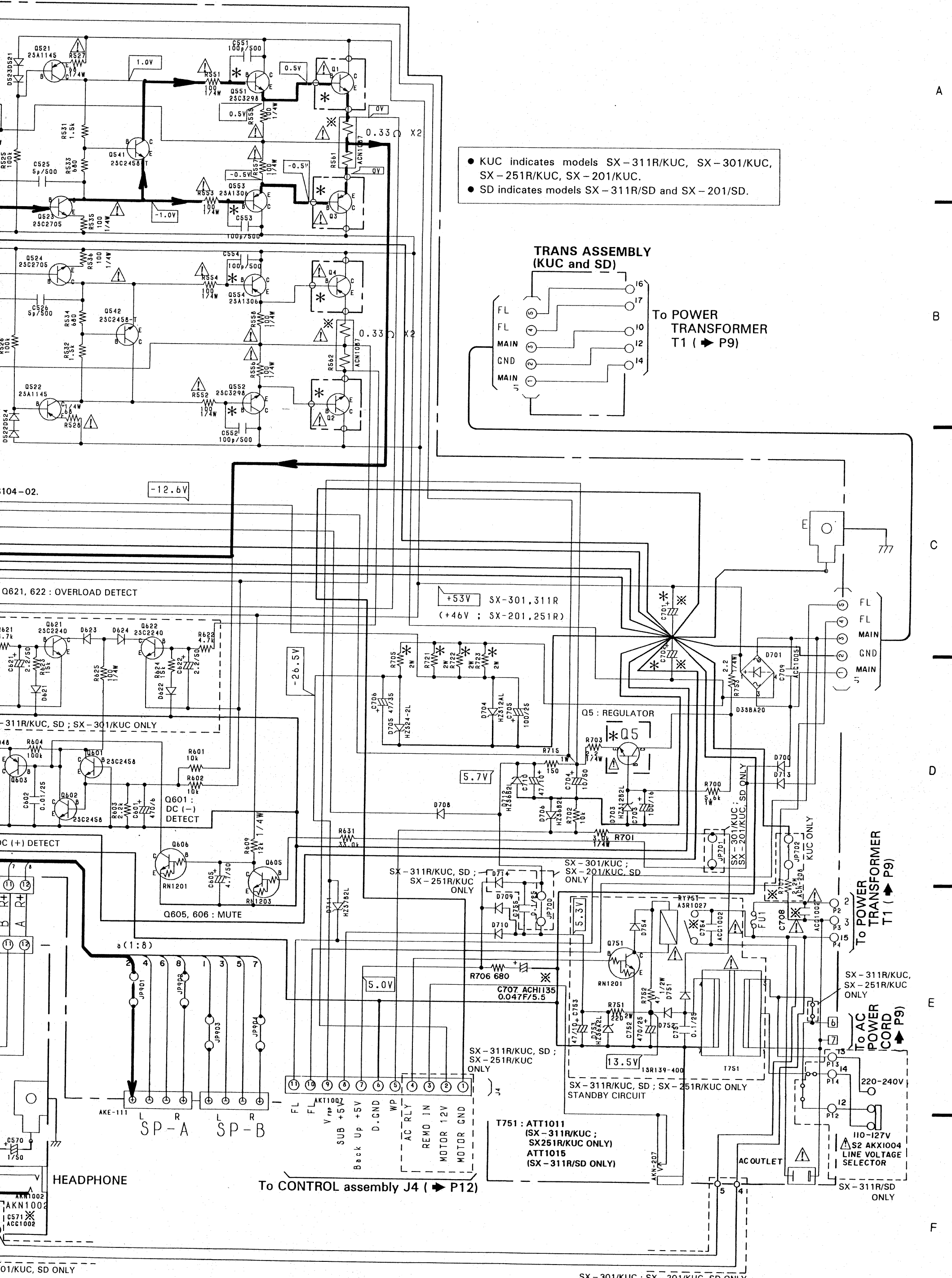

- KUC indicates models SX-311R/KUC, SX-301/KUC, SX-251R/KUC, SX-201/KUC.
- SD indicates models SX-311R/SD and SX-201/SD.

TRANS ASSEMBLY (KUC and SD)

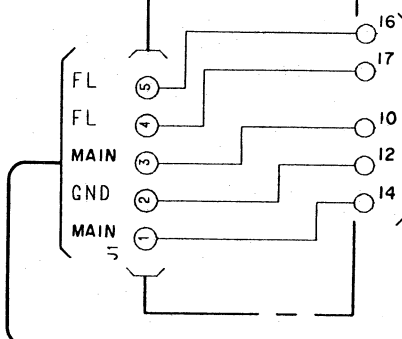

To POWER TRANSFORMER T1 (➔ P9)

+53V SX-301, 311R
(+46V : SX-201, 251R)

Q5 : REGULATOR

Q621, 622 : OVERLOAD DETECT

SX-311R/KUC, SD ; SX-301/KUC ONLY

DC (+) DETECT

Q605, 606 : MUTE

SX-311R/KUC, SD ; SX-251R/KUC ONLY

SX-301/KUC ; SX-201/KUC, SD ONLY

SX-311R/KUC, SD ; SX-251R/KUC ONLY

SX-311R/KUC, SD ; SX-251R/KUC ONLY STANDBY CIRCUIT

T751 : ATT1011 (SX-311R/KUC ; SX-251R/KUC ONLY) ATT1015 (SX-311R/SD ONLY)

To POWER TRANSFORMER T1 (➔ P9)

To AC POWER CORD (➔ P9)

110-127V S2 AKX1004 LINE VOLTAGE SELECTOR

SX-311R/SD ONLY

To CONTROL assembly J4 (➔ P12)

HEADPHONE

SP-A SP-B

SX-301/KUC ; SX-201/KUC, SD ONLY

01/KUC, SD ONLY

A

B

C

D

E

F

4.4 PCB CONNECTION DIAGRAM

- NOTE
1. This P.C.B connection diagram is viewed from the parts mounted side.
 2. The parts which have been mounted on the board can be replaced with those shown with the corresponding wiring symbols listed in the following Table.
 3. The capacitor terminal marked with ⊕ (double circles) shows negative terminal.
 4. The diode terminal marked with ⊕ (double circles) shows cathode side.
 5. The transistor terminal to which E is affixed shows the emitter.

P.C.B. pattern diagram indication	Corresponding part symbol	Part Name
		Transistor
		Radiator type transistor
		Diode
		Resistor
		Capacitor (Polarized)
		Capacitor (Non-polarized)

Others

P.C.B. pattern diagram indication	Part Name
	IC
	Switch
	Relay
	Coil
	Filter
	Variable resistor or Semi-fixed resistor

(FOR CANADIAN MODEL ONLY)
Fuse symbols (fast operating fuse) and/or (slow operating fuse) on P.C.B. indicate that replacement parts must be of identical designation.

(POUR MODÈLE CANADIEN SEULEMENT)
Sur P.C.B., les symboles de fusible (fusible de type rapide) et/ou (fusible de type lent) indiquent que les pièces de remplacement doivent avoir la même désignation.

SX-201/SD ONLY

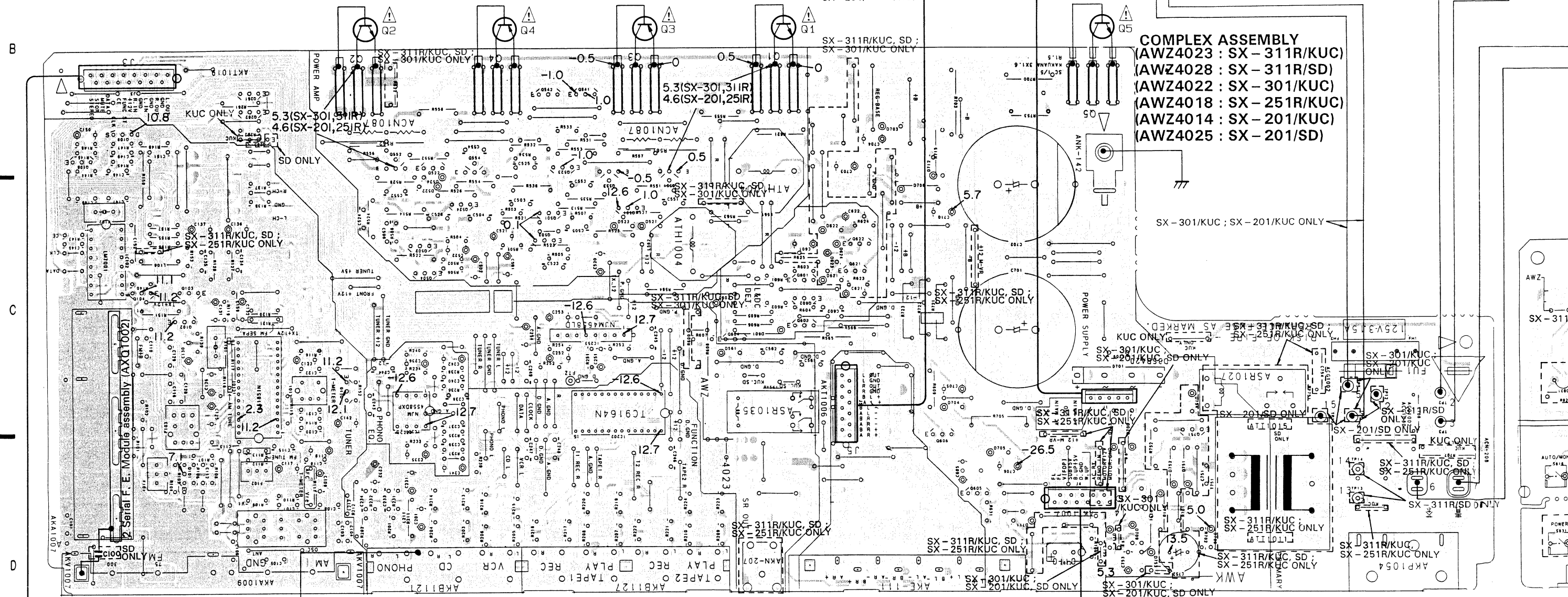
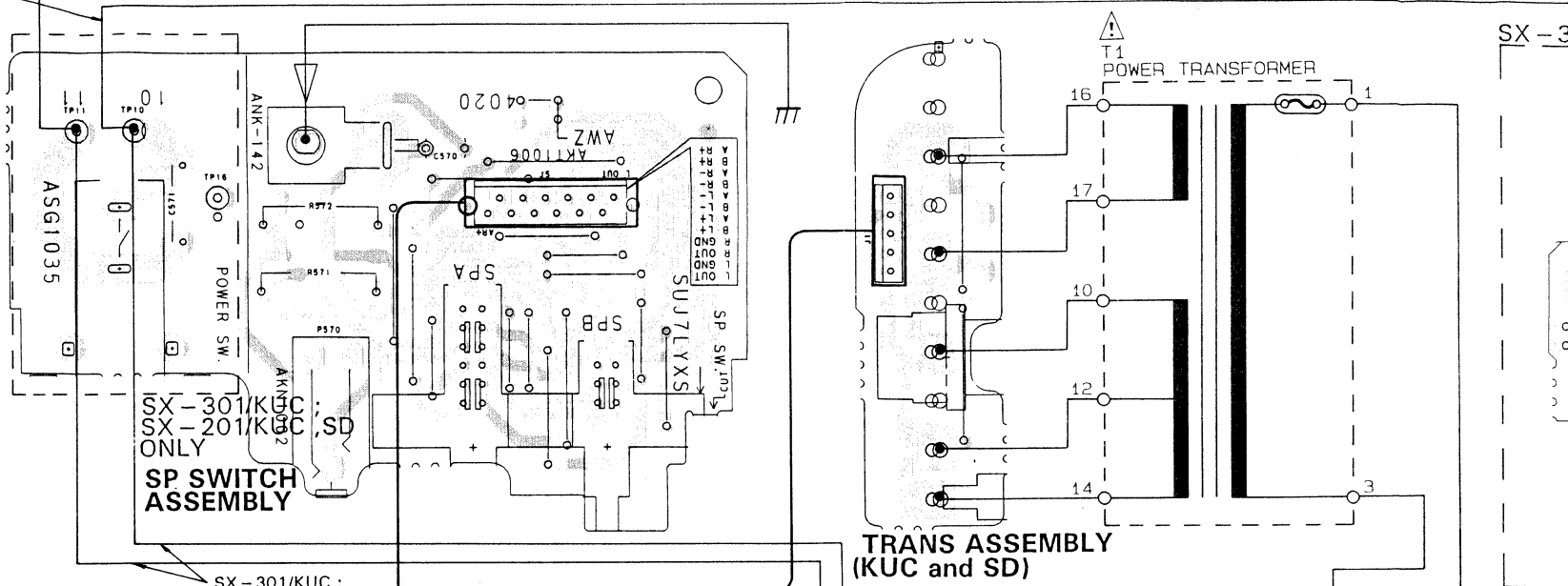

Q108 Q109 Q261-Q263 Q2 Q552 Q522 Q524 Q554 Q4 Q501 Q542 Q523 Q541 Q553 Q3 Q521 Q551 Q1 Q5 Q510 Q502 Q504 Q503 IC253 Q604 Q601-Q603 Q621 Q622 Q606 Q605 Q751

1 2 3 4 5 6

This P. C. B. connection diagram is viewed from the foil side.

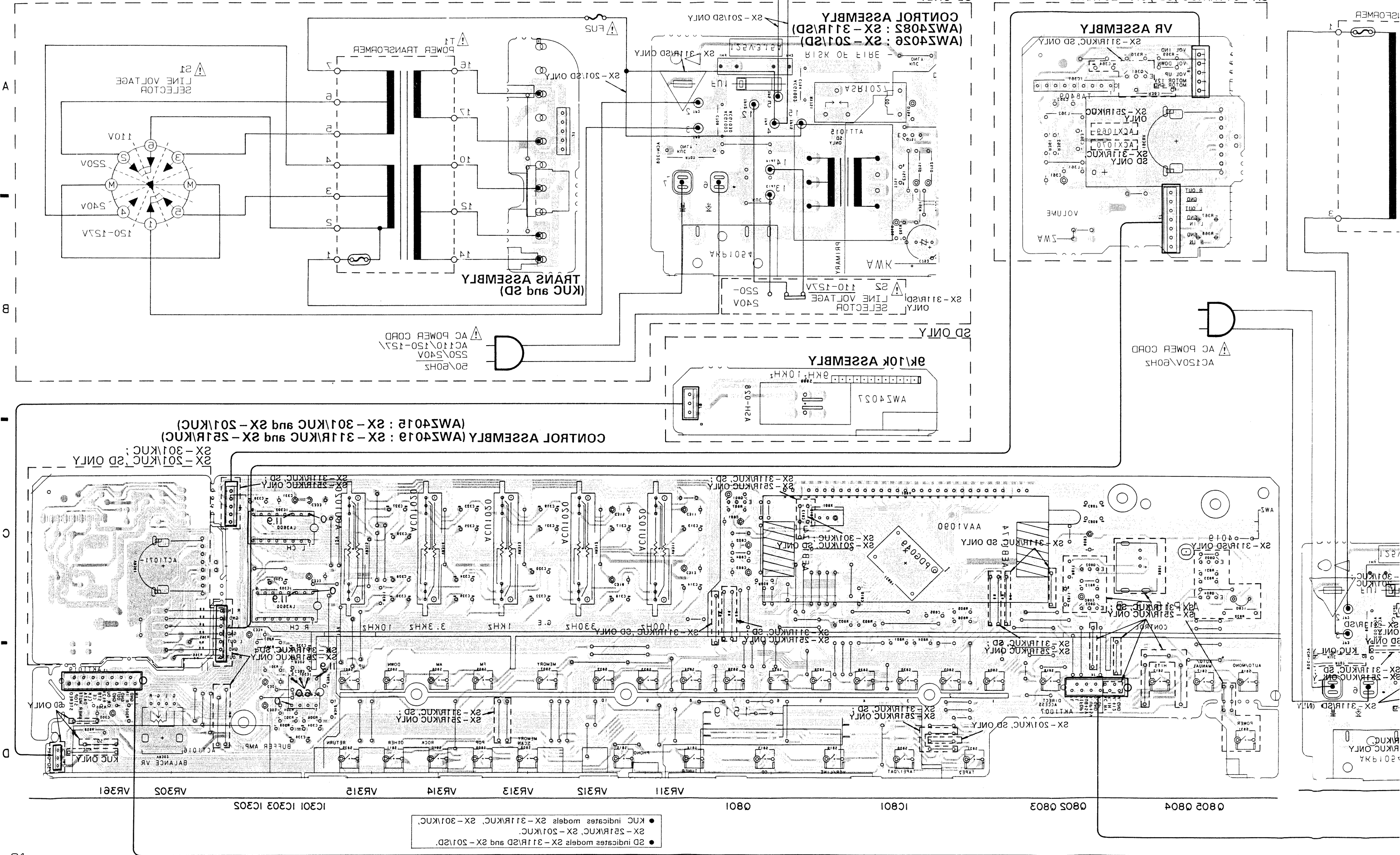

4.5 COMPLEX ASSEMBLY (2/2)(TUNER SECTION)

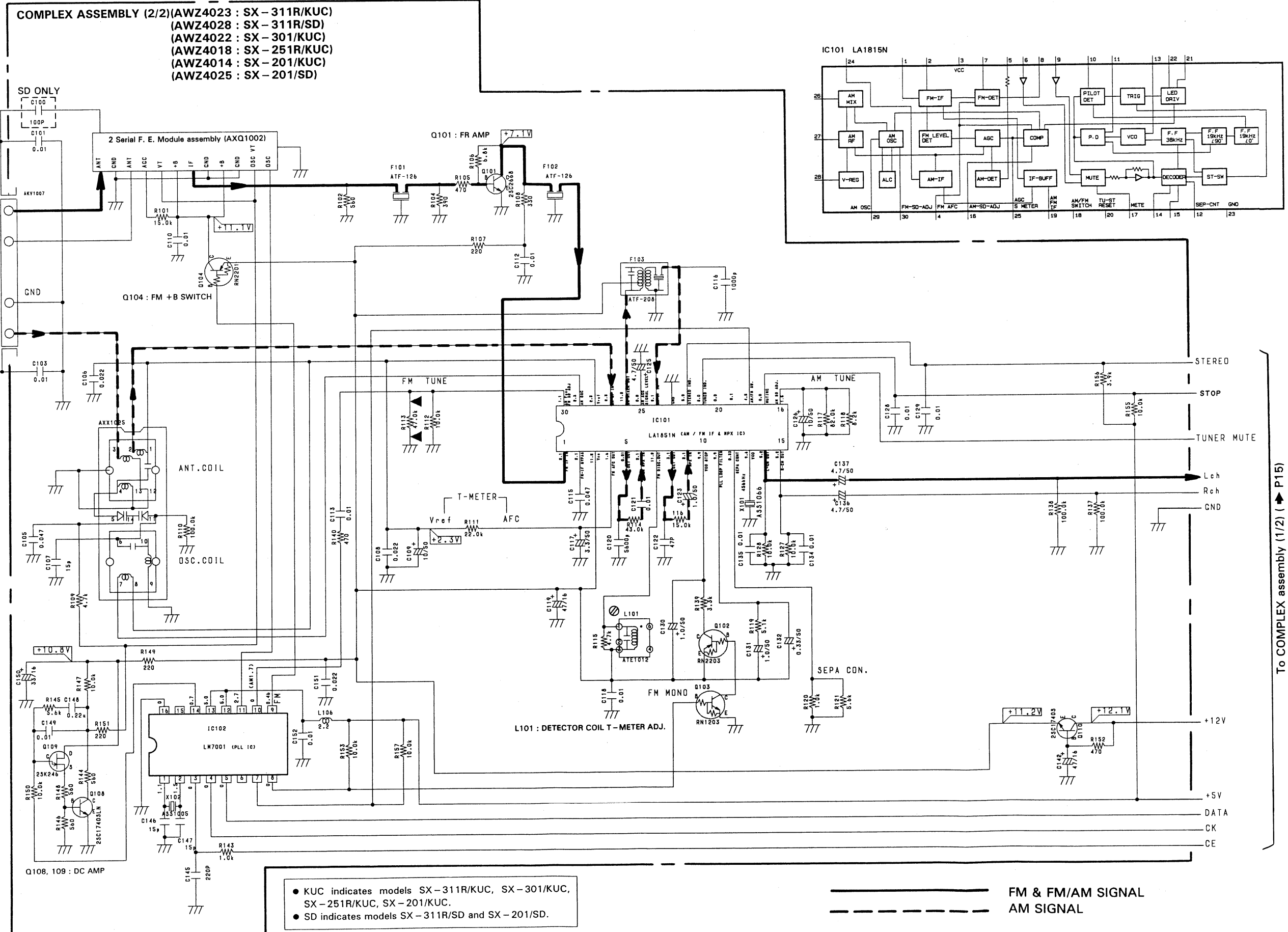

To COMPLEX assembly (1/2) (P15)

5. PCB PARTS LIST

NOTES:

- Part without part number cannot be supplied.
- Parts marked by "⊙" are not always kept in stock. Their delivery time may be longer than usual or they may be unavailable.
- The Δ mark found on some component parts indicates the importance of the safety factor of the part. Therefore, when replacing, be sure to use parts of identical designation.
- When ordering resistors, first convert resistance values into code form as shown in the following examples.

Ex. 1 When there are 2 effective digits (any digit apart from 0), such as 560 ohm and 47k ohm (tolerance is shown by J = 5%, and K = 10%).

560Ω	56 × 10 ¹	561.....	RD1/8PM ⊠ ⊠ ⊠ J
47kΩ	47 × 10 ³	473.....	RD1/4PS ⊠ ⊠ ⊠ J
0.5Ω	0R5.....		RN2H ⊠ ⊠ ⊠ K
1Ω	010.....		RS1P ⊠ ⊠ ⊠ K

Ex. 2 When there are 3 effective digits (such as in high precision metal film resistors).

5.62kΩ	562 × 10 ¹	5621.....	RN1/4SR ⊠ ⊠ ⊠ F
--------	-----------------------	-----------	-----------------

Mark No.	Description	Parts No.	Mark No.	Description	Parts No.
LIST OF ASSEMBLIES					
⊙	CONTROL ASSEMBLY	AWZ4019	C307	AXIAL CERAMIC CAPACITOR	CKPUYF103Z25
⊙	SP SWITCH ASSEMBLY		C311, 312	ELECTR. CAPACITOR	CEASR68M50
⊙	COMPLEX ASSEMBLY	AWZ4023	C313, 314	MYLAR FILM CAPACITOR	CQMA393K50
	VR ASSEMBLY		C315, 316	ELECTR. CAPACITOR	CEASR22M50
	TRANS ASSEMBLY		C317, 318	MYLAR FILM CAPACITOR	CQMA123K50
⊙	CONTROL ASSEMBLY (AWZ4019)		C319, 320	MYLAR FILM CAPACITOR	CQMA683K50
SEMICONDUCTORS					
IC301	OP-AMP IC	NJM4558DXP	C321, 322	MYLAR FILM CAPACITOR	CQMA392K50
IC302, 303	AUDIO IC	LA3600	C323, 324	MYLAR FILM CAPACITOR	CQMA223J50
IC801	RECEIVER CONTROL	PDG049-B	C325, 326	CERAMIC CAPACITOR	CKCYB122K50
Q801	TRANSISTOR	RN1203	C327, 328	MYLAR FILM CAPACITOR	CQMA682K50
Q802	TRANSISTOR	RN2201	C329, 330	CERAMIC CAPACITOR	CKCYB391K50
Q803	TRANSISTOR	RN1201	C331, 332	ELECTR. CAPACITOR	CEAS470M16
D802	DIODE	HSS104-02	C333, 334	ELECTR. CAPACITOR	CEAS220M16
SWITCHES					
S801-831	SWITCH (FREQ. UP, FREQ. DOWN, 2, 1, FM, AM, MEMORY, MEMORY SCAN, POP, ROCK, OTHER, HITS, CD, TUNER, PHONO, AUTO/MONO, AUTO/MANUAL, DIRECT ACCESS, VCR/LINE, TAPE1/DAT, TAPE2, 10, 9, 8, RETURN, 7, 6, 5, 4, 3, POWER)	ASG1034	C335, 336	CERAMIC CAPACITOR	CCMSL101J50
			C339, 340	CERAMIC CAPACITOR	CCCSL271J50
			C801	ELECTR. CAPACITOR	CEAS4R7M50
			C802	ELECTR. CAPACITOR	CEAS0R1M50
			C803	ELECTR. CAPACITOR	CEAS221M10
			C804	AXIAL CERAMIC CAPACITOR	CKPUYF103Z25
			C805	AXIAL CERAMIC CAPACITOR	CKPUYF473Z16
			C807, 808	CERAMIC CAPACITOR	CKCYF473Z50
			C809	ELECTR. CAPACITOR	CEAS100M50
			C810	AXIAL CERAMIC CAPACITOR	CKPUYF103Z25
			C811	CERAMIC CAPACITOR	CKCYX104M25
			C812	AXIAL CERAMIC CAPACITOR	CKPUYF473Z16
CAPACITORS					
C300	ELECTR. CAPACITOR	CEJA100M16			
C301, 302	ELECTR. CAPACITOR	CEAS4R7M50			
C303, 304	CERAMIC CAPACITOR	CCCSL220J50			

Mark No.	Description	Parts No.	Mark No.	Description	Parts No.
RESISTORS					
VR302	VARIABLE (500k-X1)	ACS1016	Q605	TRANSISTOR	RN1203
VR311-315	VR	ACU1020	Q606	TRANSISTOR	RN1201
			Q621, 622	TRANSISTOR	2SC2240
	Other resistors	RD1/8PM ⊠ ⊠ ⊠ J	Q751	TRANSISTOR	RN1201
OTHERS					
	FL SPACER	AEB1174	D521-524	DIODE	HSS104-02
	REMOTE RECEIVER UNIT	AXX1023	D561	DIODE	HSS104-02
			D601	ZENER DIODE	HZS12AL
V801	FL TUBE	AAV1090	D621-624	DIODE	HSS104-02
X801	CERAMIC OSCILLATOR (4.19MHz)	ASS1022	D700	DIODE	HSS104-02
SP SWITCH ASSEMBLY					
SWITCH					
S570	PUSH SWITCH	SUJ7LYXS	D701	DIODE	D3SBA20 (A)
CAPACITORS					
C570	ELECTR. CAPACITOR	CEAS010M50	D703	ZENER DIODE	HZS12B2L
RESISTORS					
R571, 572	METAL OXIDE RESISTOR	RS2LMF331J	D704	ZENER DIODE	HZS12AL
OTHERS					
	JACK (HEADPHONE)	AKN1002	D705	ZENER DIODE	HZS24-2L
			D706	ZENER DIODE	HZS6B2L
			D708-710	DIODE	HSS104-02
RELAY					
			D711	ZENER DIODE	HZS7B2L
			D712	ZENER DIODE	HZS6B2L
			D713, 714	DIODE	HSS104-02
			D751	DIODE	HSS104-02
			D752	DIODE	S5566
			D753	ZENER DIODE	HZS6A2L
			D754	DIODE	HSS104-02
COILS & TRANSFORMER					
			F101, 102	CERAMIC FILTER	ATF-126
			F103	CERAMIC FILTER	ATF-208
⊙ COMPLEX ASSEMBLY (AWZ4023)					
SEMICONDUCTORS					
IC101	AM/FM IC	LA1851N	L101	COIL	ATE1012
IC102	PLL IC	LM7001	L106	AXIAL INDUCTOR	LAU2R2M
IC201	OP-AMP IC	NJM4558DXP	L561, 562	COIL	ATH1004
IC202	E-SW IC	TC9164N	T751	POWER TRANSFORMER	ATT1011
IC253	OP-AMP IC	NJM4558LD	CAPACITORS		
Q101	TRANSISTOR	2SC2668	C101, 103	CERAMIC CAPACITOR	CKPUYY103N16
Q102	TRANSISTOR	RN2203	C105	AXIAL CERAMIC CAPACITOR	CKPUYF473Z16
Q103	TRANSISTOR	RN1203	C106	AXIAL CERAMIC CAPACITOR	CKPUYF223Z25
Q104	TRANSISTOR	RN2201	C107	AXIAL CERAMIC C.	CCPUCH150J50
Q108	TRANSISTOR	2SC1740SLN	C108	AXIAL CERAMIC CAPACITOR	CKPUYF223Z25
Q109	N-FET	2SK246	C109	ELECTR. CAPACITOR	CEAS100M50
Q110	TRANSISTOR	2SC1740S	C110	CERAMIC CAPACITOR	CKPUYY103N16
Q261, 262	TRANSISTOR	RN1203	C112, 113	CERAMIC CAPACITOR	CKPUYY103N16
Q501-504	TRANSISTOR	2SA992	C115	CERAMIC CAPACITOR	CKDYX473M25
Q521, 522	TRANSISTOR	2SA1145	C116	CERAMIC CAPACITOR	CKPUYB102Z50
Q523, 524	TRANSISTOR	2SC2705	C117	ELECTR. CAPACITOR	CEAS3R3M50
Q541, 542	TRANSISTOR	2SC2458	C118	CERAMIC CAPACITOR	CKPUYY103N16
Q551, 552	TRANSISTOR	2SC3298	C119	ELECTR. CAPACITOR	CEAS470M16
Q553, 554	TRANSISTOR	2SA1306	C120	CERAMIC CAPACITOR	CKPUYX562M16
Q601, 602	TRANSISTOR	2SC2458			
Q603	TRANSISTOR	2SA1048			
Q604	TRANSISTOR	2SC2240			

Mark No.	Description	Parts No.	Mark No.	Description	Parts No.
C121	CERAMIC CAPACITOR	CKPUYY103N16	C703	ELECTR. CAPACITOR	CEAS101M16
C122	AXIAL CERAMIC C.	CCPUSL470J50	C704	ELECTR. CAPACITOR	CEAS100M50
C123	ELECTR. CAPACITOR	CEAS010M50	C705	ELECTR. CAPACITOR	CEAS101M25
C125	ELECTR. CAPACITOR	CEAS4R7M50	C706	ELECTROLYTIC CAPACIT	CEHAQ470M35
C126	ELECTR. CAPACITOR	CEAS100M50	C707	CAPACITOR (0.047/5.5)	ACH1135
C128, 129	CERAMIC CAPACITOR	CKPUYY103N16	△ C708	CKA (0.01/AC400V)	ACG1002
C130, 131	ELECTR. CAPACITOR	CEAS010M50	C709	CKA (0.01/AC250V)	ACG1005
C132	ELECTR. CAPACITOR	CEASR33M50	C710	ELECTROLYTIC CAPACIT	CEHAQ470M10
C134, 135	CERAMIC CAPACITOR	CKCYB103K50	C751	CERAMIC CAPACITOR	CKCYX104M25
C136, 137	ELECTR. CAPACITOR	CEAS4R7M50	C752	ELECTROLYTIC CAPACIT	CEAS471M25
C142	ELECTR. CAPACITOR	CEAS470M16	C753	ELECTR. CAPACITOR	CEAS470M10
C145	CERAMIC CAPACITOR	CKPUYB221K50	△ C754	CKA (0.01/AC400V)	ACG1002
C146, 147	AXIAL CERAMIC C.	CCPUCH150J50	C755	CERAMIC CAPACITOR	CKCYX104M25
C148	AUDIO FILM CAPACITOR	CFTXA224J50	RESISTORS		
C149	AUDIO FILM CAPACITOR	CFTXA103J50	R521, 522	CARBON FILM RESISTOR	RD1/4PM432J
C150	ELECTR. CAPACITOR	CEAS330M16	R523, 524	CARBON FILM RESISTOR	RD1/4PM104J
C151	AXIAL CERAMIC CAPACITOR	CKPUYF223Z25	△ R527, 528	CARBON FILM RESISTOR	RD1/4PMF680J
C152	CERAMIC CAPACITOR	CKPUYY103N16	△ R535, 536	FUSLIBLE RESISTOR	RFA1/4PS101J
C201	ELECTR. CAPACITOR	CEAS010M50	△ R551-554	FUSLIBLE RESISTOR	RFA1/4PS101J
C231, 232	ELECTR. CAPACITOR	CEAS100M50	R555-558	CARBON FILM RESISTOR	RD1/4PMF101J
C233, 234	CERAMIC CAPACITOR	CCCSL221J50	△ R561, 562	RESISTOR (0.33, 5W)	ACN1087
C235, 236	ELECTR. CAPACITOR	CEAS470M10	△ R563, 564	CARBON FILM RESISTOR	RD1/4PMF100J
C237, 238	MYLAR FILM CAPACITOR	CQMA242J50	R565, 566	CARBON FILM RESISTOR	RD1/4PMF100J
C239, 240	MYLAR FILM CAPACITOR	CQMA822K50	△ R600	METAL OXIDE RESISTOR	RS2LMF272J
C241, 242	ELECTR. CAPACITOR	CEAS2R2M50	△ R608	METAL OXIDE RESISTOR	RS2LMF332J
C243-246	AXIAL CERAMIC CAPACITOR	CKPUYF103Z25	R609	CARBON FILM RESISTOR	RD1/4PM123J
C247, 248	CERAMIC CAPACITOR	CKCYB331K50	R625	CARBON FILM RESISTOR	RD1/4PMF101J
C249	CERAMIC CAPACITOR	CKCYB471K50	△ R700	METAL OXIDE RESISTOR	RS1PMF562J
C251, 252	ELECTR. CAPACITOR	CEAS2R2M50	R701	CARBON FILM RESISTOR	RD1/4PM302J
C253, 254	ELECTR. CAPACITOR	CEAS4R7M50	△ R703	CARBON FILM RESISTOR	RD1/4PMF2R2J
C501, 502	ELECTR. CAPACITOR	CEAS2R2M50	△ R705	METAL OXIDE RESISTOR	RS2LMF182J
C503, 504	CERAMIC CAPACITOR	CKCYB102K50	R707	RESISTOR (2.2M, 1/2W)	ACN-208
C505, 506	CERAMIC CAPACITOR	CKDYB681K50	△ R715	METAL OXIDE RESISTOR	RS1LMF151J
C520	ELECTR. CAPACITOR	CEAS101M16	R721, 722	METAL OXIDE RESISTOR	RS2LMF822J
C521, 522	ELECTR. CAPACITOR	CEAS220M16	△ R723	METAL OXIDE RESISTOR	RS2LMF103J
C523, 524	CERAMIC CAPACITOR	CCCSL120K500			
C525, 526	CERAMIC CAPACITOR	CCCSL050C500			
C551-554	CERAMIC CAPACITOR	CCCSL101K500			
C561, 562	MYLAR FILM CAPACITOR	CQMA473K50			
C601	ELECTROLYTIC CAPACIT	CEAS471M6			
C602	AXIAL CERAMIC CAPACITOR	CKPUYF103Z25			
C603	ELECTR. CAPACITOR	CEAS101M16			
C605	ELECTR. CAPACITOR	CEAS4R7M50			
C621, 622	ELECTR. CAPACITOR	CEAS2R2M50			
C701, 702	ELECTROLYTIC CAPACIT	ACH1044			

SX-311R

Mark No.	Description	Parts No.
△ R751	METAL OXIDE RESISTOR	RS2LMF221J
R752	CARBON FILM RESISTOR	RD1/2PM470J
△ R753	CARBON FILM RESISTOR	RD1/4PMFL2R2J
	Other resistors	RD1/8PM□□□J

OTHERS

X101	CRYSTAL RESONATOR (456kHz)	ASS1066
X102	CRYSTAL RESONATOR (7.2MHz)	ASS1005
	ANTENNA TERMINAL 4-P	AKA1009
	PIN JACK 6P (PHONO, CD, VCR/LD)	AKB1121
	PIN JACK 8P (TAPE1/DAT, TAPE2 MONITOR)	AKB1127
	SPEAKER TERMINAL 8-P	AKE-111
	JACK (CONTROL)	AKN-207
	AC OUTLET (1P)	AKP1054
	AM RF TUNING BLOCK	AXX1025
	2 SERIAL F.E. MODULE ASSEMBLY (This assembly has no service part.)	AXQ1002

VR ASSEMBLY

SEMICONDUCTORS

IC361	MECHANISM DRIVER IC	TA8409S
Q361	TRANSISTOR	RN1201

COILS

L361, 362	AXIAL INDUCTOR	LAU101K
-----------	----------------	---------

CAPACITORS

C361	ELECTR. CAPACITOR	CEAS470M16
C362, 363	CERAMIC CAPACITOR	CKCYF473Z50
C364	CERAMIC CAPACITOR	CKCYX104M25

RESISTORS

VR361	MOTOR VR WITH LED	ACX1070
	Other resistors	RD1/8PM□□□J

TRANS ASSEMBLY

TRANS assembly has no service part.

6. ADJUSTMENTS

- For connections and points to be adjusted, refer to Fig. 6-1, Fig. 6-2 and Fig. 6-3.

6.1 AM TUNER ADJUSTMENT

- Set the BAND selector "AM".

Step No.	Adjustment Title	AM SG (400Hz 30% Mod.)		Reception Frequency Display	Adjustment Location	Specifications
		Frequency (kHz)	Level (dB μ V)			
1	TUNED indicator sensitivity check	1000	—	1000kHz	R117	Check that the indicator lights up when the level is less than 64dB μ V/m. *1

*1. Remove R117 if the indicator does not light up.

6.2 FM TUNER ADJUSTMENT

- Set the BAND selector to "FM".
- Perform VCO adjustment two minutes or more after turning the power ON.

Note :
 Stereo modulation : Main 1kHz L+R \pm 68.25kHz dev.
 Pilot 19kHz \pm 6.75kHz dev.

Step No.	Adjustment Title	FM SG (1kHz \pm 75kHz dev.)		Reception Frequency Display	Adjustment Location	Specifications
		Frequency (MHz)	Level (dB μ V)			
1	Detector coil T-meter adjustment	98.0	60	98.0MHz	L101	Adjust so that the DC voltage between both sides of R111 is 0 \pm 50mV.
2	Separation check	98.0	60	98.0MHz	R121 *1	Check that the separation is 23dB or more (at 1kHz).
3	TUNED indicator sensitivity check	98.0	20 \pm 13	98.0MHz	R113 *2	Check that the indicator lights up.

*1. Remove R121 if the separation is less than 23dB.

*2. Remove R113 if the indicator does not light up.

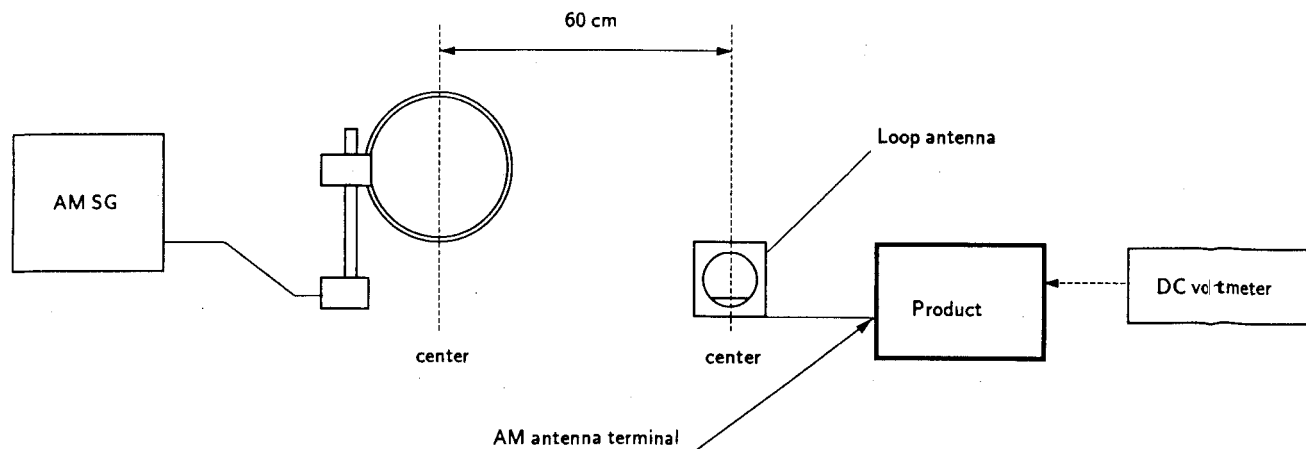

Fig. 6-1 AM Adjustment Connection Diagram

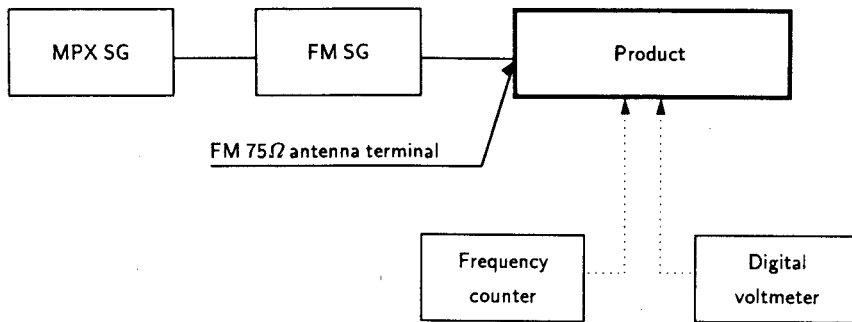

Fig. 6-2 FM Adjustment Connection Diagram

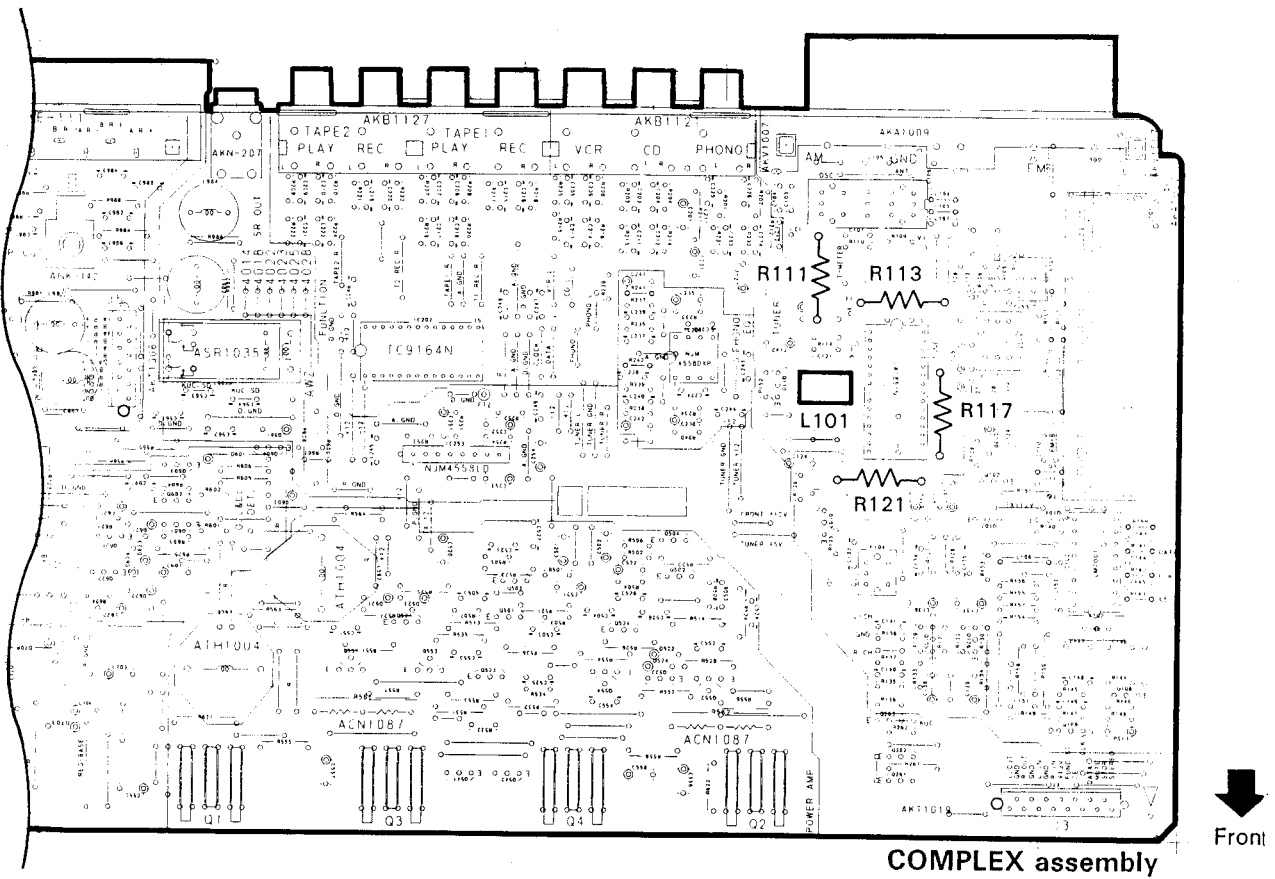

Fig. 6-3 Adjustment Points

7. FOR SX – 311R/SD, KUC/CA, SX – 301/KUC, SX – 251R/KUC, KUC/CA, SX – 201/KUC, SD AND KUC/CA TYPES

- KUC/CA type is identical to KUC type but with additional (French) operating instructions :

Model Name	Operating Instructions (French)
SX – 311R/KUC/CA	ARC1348
SX – 251R/KUC/CA	ARC1348
SX – 201/KUC/CA	ARC1348

7.1 CONTRAST OF MISCELLANEOUS PARTS

NOTES:

- Part without part number cannot be supplied.
- The Δ mark found on some component parts indicates the importance of the safety factor of the part. Therefore, when replacing, be sure to use parts of identical designation.
- Parts marked by "●" are not always kept in stock. Their delivery time may be longer than usual or they may be unavailable.

SX – 311R/SD, SX – 301/KUC, SX – 251R/KUC, SX – 201/KUC, SD and SX – 311R/KUC have the same construction except for the following :

Mark	Symbol & Description	Part No.						Remarks
		SX – 311R/ KUC type	SX – 311R/ SD type	SX – 301/ KUC type	SX – 251R/ KUC type	SX – 201/ KUC type	SX – 201/ SD type	
●	COMPLEX assembly	AWZ4023	AWZ4028	AWZ4022	AWZ4018	AWZ4014	AWZ4025	
●	CONTROL assembly	AWZ4019	AWZ4082	AWZ4015	AWZ4019	AWZ4015	AWZ4026	
	SP SWITCH assembly	Non supply	Non supply	Non supply	Non supply	Non supply	Non supply	*1
	9k/10k assembly	Non supply	Non supply	*2
	VR assembly	Non supply	Non supply	Non supply	*3
Δ	Q1, Q2 Transistor	2SC4689	2SC4689	2SC4689	2SC4688	2SC4688	2SC4688	
Δ	Q3, Q4 Transistor	2SA1804	2SA1804	2SA1804	2SA1803	2SA1803	2SA1803	
Δ	S1 Line voltage selector (AC110V/120–127V/220V/240V)	AKX – 507	AKX – 507	
Δ	S2 Line voltage selector (AC110–127V/220–240V)	AKX1004	
Δ	T1 Power transformer	ATS1409	ATS1411	ATS1409	ATS1408	ATS1408	ATS1410	
Δ	FU1 Fuse (4A/125V)	AEK – 125	AEK – 125	
Δ	FU1 Fuse (2A/125V)	AEK – 122	
Δ	FU1 Fuse (3.15A/125V)	AEK – 124	AEK – 124	
Δ	FU1 Fuse (1.6A/125V)	AEK – 121	
Δ	FU2 Fuse (2A/125V)	AEK – 122	
Δ	FU2 Fuse (1.6A/125V)	AEK – 121	
Δ	Fuse holder	AKR1001	AKR1001	
Δ	AC Power cord	ADG1058	ADG1051	ADG1058	ADG1058	ADG1058	ADG1051	
Δ	Strain relief	AEP – 113	AEC – 882	AEP – 113	AEP – 113	AEP – 113	AEC – 882	
	Display panel	AAK2277	AAK2278	AAK2276	AAK2277	AAK2276	AAK2276	
	Rotary knob assy	AAB1275	AAB1275	
	Rotary knob	AAB1277	AAB1277	AAB1277	AAB1277	
	Insulation spacer	Non supply	

SX-311R/SX-301
SX-251R/SX-201

Mark	Symbol & Description	Part No.						Remarks
		SX-311R/ KUC type	SX-311R/ SD type	SX-301/ KUC type	SX-251R/ KUC type	SX-201/ KUC type	SX-201/ SD type	
	Front panel	AMB1950	AMB1950	AMB1970	AMB1969	AMB1949	AMB1949	
	Insulator assy	AMR2140	AMR2140	
	Leg assy	AEC-784	AEC-784	AEC-784	AEC-784	
	Bonnet case	ANE1334	ANE1334	ANE1334	ANE1343	ANE1343	ANE1343	
	Screw	BBZ26P120FMC	BBZ26P120FMC	Fuse holder *4
	Screw	PMZ30P040FMC	PMZ30P040FMC	
	Screw	ABA1009	ABA1009	
	Packing case	AHD2225	AHD2227	AHD2224	AHD2223	AHD2222	AHD2226	
	Remote control unit (CU-SX042)	AXD1259	AXD1259	AXD1259	
	Battery cover	AZA1297	AZA1297	AZA1297	
	Operating instructions (Spanish)	ARC1332	ARC1332	

*1 : SP SWITCH assemblies of SX-311R/KUC, SD and SX-251R/KUC types are the same.

SP SWITCH assemblies of SX-301/KUC, SX-201/KUC and SD types are the same.

*2 : 9k/10k assemblies of SX-311R/SD and SX-201/SD types are the same.

*3 : VR assemblies of SX-311R/KUC and SD types are the same.

*4 : For Channel step selector.

● **CONTROL ASSEMBLY (AWZ4082, AWZ4015, AWZ4026)**

CONTROL assembly (AWZ4082, AWZ4015, AWZ4026) and CONTROL assembly (AWZ4019) have the same construction except for the following :

Mark	Symbol & Description	Part No.				Remarks
		AWZ4019	AWZ4082	AWZ4015	AWZ4026	
	Q802	RN2201	RN2201	
	Q803	RN1201	RN1201	
	Q804	RN1203	
	Q805	2SC2458	
	D802	HSS104-02	HSS104-02	
	D821	AEL1108	
	S831	ASG1034	ASG1034	
	C811	CKCYX104M25	CKCYX104M25	
	C812	CKPUYF473Z16	CKPUYF473Z16	
	VR361	ACT1071	ACT1071	
	R365, R366	RD1/8PM102J	RD1/8PM102J	
	R811, R812	RD1/8PM472J	RD1/8PM472J	
	R821	RD1/8PM472J	
	R822	RD1/4PM221J	
	R823	RD1/8PM562J	
	Remote control sensor unit	AXX1023	AXX1023	

◎ **COMPLEX ASSEMBLY (AWZ4028, AWZ4022)**

COMPLEX assembly (AWZ4028, AWZ4022) and COMPLEX assembly (AWZ4023) have the same construction except for the following :

Mark	Symbol & Description	Part No.			Remarks
		AWZ4023	AWZ4028	AWZ4022	
	Q263	RN2203	
	Q751	RN1201	RN1201	
	D714, D751, D754	HSS104-02	HSS104-02	
	D752	S5566	S5566	
	D753	HZS6A2L	HZS6A2L	
	RY751	ASR1027	ASR1027	
	T751	ATT1011	ATT1015	
	C100	CCDSL101J50	
△	C708 (0.01/AC400V)	ACG1002	ACG1002	
△	C708 (0.022/AC400V)	ACG1030	
	C751, C755	CKCYX104M25	CKCYX104M25	
	C752	CEAS471M25	CEAS471M25	
	C753	CEAS470M10	CEAS470M10	
△	C754 (0.01/AC400V)	ACG1002	ACG1002	
	R707 (2.2M, 1/2W)	ACN-208	ACN-208	
△	R751	RS2LMF221J	RS2LMF221J	
	R752	RD1/2PM470J	RD1/2PM470J	
	Mini jack (CONTROL)	AKN-207	AKN-207	

VR ASSEMBLY (SX-251R/KUC)

VR assembly (SX-251R/KUC) and VR assembly (SX-311R/KUC) have the same construction except for the following :

Mark	Symbol & Description	Part No.		Remarks
		SX-311R/KUC	SX-251R/KUC	
	Q361	RN1201	
	C364	CKCYX104M25	
	VR361	ACX1070	ACX1069	
	R363	RD1/8PM182J	

SX-311R/SX-301 SX-251R/SX-201

SP SWITCH ASSEMBLY (SX-301/KUC, SX-201/KUC and SX-201/SD)

SP SWITCH assembly (SX-301/KUC, SX-201/KUC, SD) and SP SWITCH assembly (SX-311R/KUC) have the same construction except for the following :

Mark	Symbol & Description	Part No.		Remarks
		SX-311R/KUC	SX-301/KUC, SX-201/KUC, SD	
	S1	ASG1035	
△	C571 (0.01/AC400V)	ACG1002	

7.2 PCB PARTS LIST

NOTES:

- Part without part number cannot be supplied.
- Parts marked by "●" are not always kept in stock. Their delivery time may be longer than usual or they may be unavailable.
- The △ mark found on some component parts indicates the importance of the safety factor of the part. Therefore, when replacing, be sure to use parts of identical designation.
- When ordering resistors, first convert resistance values into code form as shown in the following examples.

Ex. 1 When there are 2 effective digits (any digit apart from 0), such as 560 ohm and 47k ohm (tolerance is shown by J = 5%, and K = 10%).

560Ω 56 × 10¹ 561.....RD1/8PM [5] [6] [J]
 47kΩ 47 × 10³ 473.....RD1/4PS [4] [7] [J]
 0.5Ω 0R5.....RN2H [0] [5] [K]
 1Ω 010.....RS1P [0] [1] [K]

Ex. 2 When there are 3 effective digits (such as in high precision metal film resistors).

5.62kΩ 562 × 10¹ 5621.....RN1/4SR [5] [6] [2] [F]

Mark No.	Description	Parts No.	Mark No.	Description	Parts No.
● COMPLEX ASSEMBLY (AWZ4018 : SX-251R/KUC)			Q605	TRANSISTOR	RN1203
SEMICONDUCTORS			Q606	TRANSISTOR	RN1201
IC101	AM/FM IC	LA1851N	Q751	TRANSISTOR	RN1201
IC102	PLL IC	LM7001	D521-524	DIODE	HSS104-12
IC201	OP-AMP IC	NJM4558DXP	D561	DIODE	HSS104-12
IC202	E-SW IC	TC9164N	D601	ZENER DIODE	HZS12AL
IC253	OP-AMP IC	NJM4558LD	D700	DIODE	HSS104-12
Q101	TRANSISTOR	2SC2668	D701	DIODE	D3SBA20(A)
Q102	TRANSISTOR	RN2203	D703	ZENER DIODE	HZS12B2L
Q103	TRANSISTOR	RN1203	D704	ZENER DIODE	HZS12AL
Q104	TRANSISTOR	RN2201	D705	ZENER DIODE	HZS24-2L
Q108	TRANSISTOR	2SC1740SLN	D706	ZENER DIODE	HZS6B2L
Q109	N-FET	2SK246	D708-710	DIODE	HSS104-12
Q110	TRANSISTOR	2SC1740S	D711	ZENER DIODE	HZS7B2L
Q261, 262	TRANSISTOR	RN1203	D712	ZENER DIODE	HZS6B2L
Q501-504	TRANSISTOR	2SA992	D713, 714	DIODE	HSS104-12
Q521, 522	TRANSISTOR	2SA1145	D751	DIODE	HSS104-12
Q523, 524	TRANSISTOR	2SC2705	D752	DIODE	S5566
Q541, 542	TRANSISTOR	2SC2458	D753	ZENER DIODE	HZS6A2L
Q551, 552	TRANSISTOR	2SC2235	D754	DIODE	HSS104-12
Q553, 554	TRANSISTOR	2SA965	RELAY		
Q601, 602	TRANSISTOR	2SC2458	RY561	RELAY	ASR1035
Q603	TRANSISTOR	2SA1048	RY751	RELAY	ASR1027
Q604	TRANSISTOR	2SC2240			

Mark No.	Description	Parts No.	Mark No.	Description	Parts No.
COILS & TRANSFORMER			C239, 240	MYLAR FILM CAPACITOR	CQMA822K50
F101, 102	CERAMIC FILTER	ATF-126	C241, 242	ELECTR. CAPACITOR	CEAS2R2M50
F103	CERAMIC FILTER	ATF-208	C243-246	AXIAL CERAMIC CAPACITOR	CKPUYF103Z25
L101	COIL	ATE1012	C247, 248	CERAMIC CAPACITOR	CKCYB331K50
L106	AXIAL INDUCTOR	LAU2R2M	C249	CERAMIC CAPACITOR	CKCYB471K50
L561, 562	COIL	ATH1004	C251, 252	ELECTR. CAPACITOR	CEAS2R2M50
T751	POWER TRANSFORMER	ATT1011	C253, 254	ELECTR. CAPACITOR	CEAS4R7M50
CAPACITORS			C501, 502	ELECTR. CAPACITOR	CEAS2R2M50
C101, 103	CERAMIC CAPACITOR	CKPUYY103N16	C503, 504	CERAMIC CAPACITOR	CKCYB102K50
C105	AXIAL CERAMIC CAPACITOR	CKPUYF473Z16	C505, 506	CERAMIC CAPACITOR	CKDYB681K50
C106	AXIAL CERAMIC CAPACITOR	CKPUYF223Z25	C520	ELECTR. CAPACITOR	CEAS101M16
C107	AXIAL CERAMIC C.	CCPUCH150J50	C521, 522	ELECTR. CAPACITOR	CEAS220M16
C108	AXIAL CERAMIC CAPACITOR	CKPUYF223Z25	C523, 524	CERAMIC CAPACITOR	CCCSL120K500
C109	ELECTR. CAPACITOR	CEAS100M50	C525, 526	CERAMIC CAPACITOR	CCCSL050C500
C110	CERAMIC CAPACITOR	CKPUYY103N16	C551-554	CERAMIC CAPACITOR	CCCSL101K500
C112, 113	CERAMIC CAPACITOR	CKPUYY103N16	C561, 562	MYLAR FILM CAPACITOR	CQMA473K50
C115	CERAMIC CAPACITOR	CKDYX473M25	C601	ELECTROLYTIC CAPACIT	CEAS471M6
C116	CERAMIC CAPACITOR	CKPUYB102K50	C602	AXIAL CERAMIC CAPACITOR	CKPUYF103Z25
C117	ELECTR. CAPACITOR	CEAS3R3M50	C603	ELECTR. CAPACITOR	CEAS101M16
C118	CERAMIC CAPACITOR	CKPUYY103N16	C605	ELECTR. CAPACITOR	CEAS4R7M50
C119	ELECTR. CAPACITOR	CEAS470M16	C701, 702	ELECTROLYTIC CAPACIT	ACH1145
C120	CERAMIC CAPACITOR	CKPUYX562M16	C703	ELECTR. CAPACITOR	CEAS101M16
C121	CERAMIC CAPACITOR	CKPUYY103N16	C704	ELECTR. CAPACITOR	CEAS100M50
C122	AXIAL CERAMIC C.	CCPUSL470J50	C705	ELECTR. CAPACITOR	CEAS101M25
C123	ELECTR. CAPACITOR	CEAS010M50	C706	ELECTROLYTIC CAPACIT	CEHAQ470M35
C125	ELECTR. CAPACITOR	CEAS4R7M50	C707	CAPACITOR (0.047/5.5)	ACH1135
C126	ELECTR. CAPACITOR	CEAS100M50	△ C708	CKA (0.01/AC400V)	ACG1002
C128, 129	CERAMIC CAPACITOR	CKPUYY103N16	C709	CKA (0.01/AC250V)	ACG1005
C130, 131	ELECTR. CAPACITOR	CEAS010M50	C710	ELECTROLYTIC CAPACIT	CEHAQ470M10
C132	ELECTR. CAPACITOR	CEASR33M50	C751	CERAMIC CAPACITOR	CKCYX104M25
C134, 135	CERAMIC CAPACITOR	CKCYB103K50	C752	ELECTROLYTIC CAPACIT	CEAS471M25
C136, 137	ELECTR. CAPACITOR	CEAS4R7M50	C753	ELECTR. CAPACITOR	CEAS470M10
C142	ELECTR. CAPACITOR	CEAS470M16	△ C754	CKA (0.01/AC400V)	ACG1002
C145	CERAMIC CAPACITOR	CKPUYB221K50	C755	CERAMIC CAPACITOR	CKCYX104M25
C146, 147	AXIAL CERAMIC C.	CCPUCH150J50	RESISTORS		
C148	AUDIO FILM CAPACITOR	CFTXA224J50	R521, 522	CARBON FILM RESISTOR	RD1/4PM562J
C149	AUDIO FILM CAPACITOR	CFTXA103J50	R523, 524	CARBON FILM RESISTOR	RD1/4PM104J
C150	ELECTR. CAPACITOR	CEAS330M16	△ R527, 528	CARBON FILM RESISTOR	RD1/4PMF680J
C151	AXIAL CERAMIC CAPACITOR	CKPUYF223Z25	△ R535, 536	FUSLIBLE RESISTOR	RFA 1/4PS101J
C152	CERAMIC CAPACITOR	CKPUYY103N16	△ R551-554	FUSLIBLE RESISTOR	RFA 1/4PS101J
C201	ELECTR. CAPACITOR	CEAS010M50	R555-558	CARBON FILM RESISTOR	RD1/4PMF101J
C231, 232	ELECTR. CAPACITOR	CEAS100M50	△ R561, 562	RESISTOR (0.33, 5W)	ACN1087
C233, 234	CERAMIC CAPACITOR	CCCSL221J50			
C235, 236	ELECTR. CAPACITOR	CEAS470M10			
C237, 238	MYLAR FILM CAPACITOR	CQMA242J50			

SX-311R/SX-301 SX-251R/SX-201

Mark No.	Description	Parts No.
△ R563, 564	CARBON FILM RESISTOR	RD1/4PMF100J
R565, 566	CARBON FILM RESISTOR	RD1/4PMF100J
△ R608	METAL OXIDE RESISTOR	RS2LMF911J
R609	CARBON FILM RESISTOR	RD1/4PM123J
△ R700	METAL OXIDE RESISTOR	RS1PMF562J
R701	CARBON FILM RESISTOR	RD1/4PM302J
△ R703	CARBON FILM RESISTOR	RD1/4PMF2R2J
△ R705	METAL OXIDE RESISTOR	RS2LMF122J
R707	RESISTOR (2.2M, 1/2W)	ACN-208
△ R715	METAL OXIDE RESISTOR	RS1LMF151J
△ R721-723	METAL OXIDE RESISTOR	RS2LMF682J
△ R751	METAL OXIDE RESISTOR	RS2LMF221J
R752	CARBON FILM RESISTOR	RD1/2PM470J
△ R753	CARBON FILM RESISTOR	RD1/4PMFL2R2J
	Other resistors	RD1/8PM□□□J
OTHERS		
X101	CRYSTAL RESONATOR (456kHz)	ASS1066
X102	CRYSTAL RESONATOR (7.2MHz)	ASS1005
	ANTENNA TERMINAL 4-P	AKA1009
	PIN JACK 6P (PHONO, CD, VCR/LD)	AKB1121
	PIN JACK 8P (TAPE1/DAT, TAPE2 MONITOR)	AKB1127
	SPEAKER TERMINAL 8-P	AKE-111
	JACK (CONTROL)	AKN-207
	AC OUTLET (1P)	AKP1054
	AM RF TUNING BLOCK	AXX1025
	2 SERIAL F.E. MODULE ASSEMBLY	AXQ1002
	(This assembly has no service part.)	

◎ COMPLEX ASSEMBLY (AWZ4014 : SX-201/KUC) SEMICONDUCTORS

IC	Description	Parts No.
IC101	AM/FM IC	LA1851N
IC102	PLL IC	LM7001
IC201	OP-AMP IC	NJM4558DXP
IC202	E-SW IC	TC9164N
IC253	OP-AMP IC	NJM4558LD
Q101	TRANSISTOR	2SC2668
Q102	TRANSISTOR	RN2203
Q103	TRANSISTOR	RN1203
Q104	TRANSISTOR	RN2201
Q108	TRANSISTOR	2SC1740SLN
Q109	N-FET	2SK246
Q110	TRANSISTOR	2SC1740S
Q261, 262	TRANSISTOR	RN1203
Q501-504	TRANSISTOR	2SA992
Q521, 522	TRANSISTOR	2SA1145
Q523, 524	TRANSISTOR	2SC2705
Q541, 542	TRANSISTOR	2SC2458
Q551, 552	TRANSISTOR	2SC2235
Q553, 554	TRANSISTOR	2SA965
Q601, 602	TRANSISTOR	2SC2458
Q603	TRANSISTOR	2SA1048
Q604	TRANSISTOR	2SC2240
Q605	TRANSISTOR	RN1203
Q606	TRANSISTOR	RN1201
D521-524	DIODE	HSS104-02
D561	DIODE	HSS104-02
D601	ZENER DIODE	HZS12AL
D700	DIODE	HSS104-02
D701	DIODE	D3SBA20 (A)
D703	ZENER DIODE	HZS12B2L
D704	ZENER DIODE	HZS12AL
D705	ZENER DIODE	HZS24-2L
D706	ZENER DIODE	HZS6B2L
D708-710	DIODE	HSS104-02
D711	ZENER DIODE	HZS7B2L
D712	ZENER DIODE	HZS6B2L
D713	DIODE	HSS104-02

RELAY

RY561	RELAY	ASR1035
-------	-------	---------

COILS

F101, 102	CERAMIC FILTER	ATF-126
F103	CERAMIC FILTER	ATF-208
L101	COIL	ATE1012
L106	AXIAL INDUCTOR	LAU2R2M
L561, 562	COIL	ATH1004

CAPACITORS

C101, 103	CERAMIC CAPACITOR	CKPUYY103N16
C105	AXIAL CERAMIC CAPACITOR	CKPUYF473Z16

SX-311R/SX-301 SX-251R/SX-201

Mark No.	Description	Parts No.
△ R753	CARBON FILM RESISTOR	RD1/4PMFL2R2J
	Other resistors	RD1/8PM□□□J
OTHERS		
X101	CRYSTAL RESONATOR (456kHz)	ASS1066
X102	CRYSTAL RESONATOR (7.2MHz)	ASS1005
	ANTENNA TERMINAL 4-P	AKA1009
	PIN JACK 6P (PHONO, CD, VCR/LD)	AKB1121
	PIN JACK 8P (TAPE1/DAT, TAPE2 MONITOR)	AKB1127
	SPEAKER TERMINAL 8-P	AKE-111
	AC OUTLET (1P)	AKP1054
	AM RF TUNING BLOCK 2 SERIAL F.E. MODULE ASSEMBLY (This assembly has no service part.)	AXX1025 AXQ1002

◎ COMPLEX ASSEMBLY (AWZ4025 : SX-201/SD)

SEMICONDUCTORS

IC101	AM/FM IC	LA1851N
IC102	PLL IC	LM7001
IC201	OP-AMP IC	NJM4558DXP
IC202	E-SW IC	TC9164N
IC253	OP-AMP IC	NJM4558LD
Q101	TRANSISTOR	2SC2668
Q102	TRANSISTOR	RN2203
Q103	TRANSISTOR	RN1203
Q104	TRANSISTOR	RN2201
Q108	TRANSISTOR	2SC1740SLN
Q109	N-FET	2SK246
Q110	TRANSISTOR	2SC1740S
Q261, 262	TRANSISTOR	RN1203
Q263	TRANSISTOR	RN2203
Q501-504	TRANSISTOR	2SA992
Q521, 522	TRANSISTOR	2SA1145
Q523, 524	TRANSISTOR	2SC2705
Q541, 542	TRANSISTOR	2SC2458
Q551, 552	TRANSISTOR	2SC2235
Q553, 554	TRANSISTOR	2SA965
Q601, 602	TRANSISTOR	2SC2458
Q603	TRANSISTOR	2SA1048
Q604	TRANSISTOR	2SC2240
Q605	TRANSISTOR	RN1203
Q606	TRANSISTOR	RN1201
D521-524	DIODE	HSS104-02
D561	DIODE	HSS104-02
D601	ZENER DIODE	HZS12AL

Mark No.	Description	Parts No.
D700	DIODE	HSS104-02
D701	DIODE	D3SBA20 (A)
D703	ZENER DIODE	HZS12B2L
D704	ZENER DIODE	HZS12AL
D705	ZENER DIODE	HZS24-2L
D706	ZENER DIODE	HZS6B2L
D708-710	DIODE	HSS104-02
D711	ZENER DIODE	HZS7B2L
D712	ZENER DIODE	HZS6B2L
D713	DIODE	HSS104-02
RELAY		
RY561	RELAY	ASR1035
COILS		
F101, 102	CERAMIC FILTER	ATF-126
F103	CERAMIC FILTER	ATF-208
L101	COIL	ATE1012
L106	AXIAL INDUCTOR	LAU2R2M
L561, 562	COIL	ATH1004
CAPACITORS		
C100	CERAMIC CAPACITOR	CCDSL101J50
C101, 103	CERAMIC CAPACITOR	CKPUYY103N16
C105	AXIAL CERAMIC CAPACITOR	CKPUYF473Z16
C106	AXIAL CERAMIC CAPACITOR	CKPUYF223Z25
C107	AXIAL CERAMIC C.	CCPUCH150J50
C108	AXIAL CERAMIC CAPACITOR	CKPUYF223Z25
C109	ELECTR. CAPACITOR	CEAS100M50
C110	CERAMIC CAPACITOR	CKPUYY103N16
C112, 113	CERAMIC CAPACITOR	CKPUYY103N16
C115	CERAMIC CAPACITOR	CKDYX473M25
C116	CERAMIC CAPACITOR	CKPUYB102K50
C117	ELECTR. CAPACITOR	CEAS3R3M50
C118	CERAMIC CAPACITOR	CKPUYY103N16
C119	ELECTR. CAPACITOR	CEAS470M16
C120	CERAMIC CAPACITOR	CKPUYX52M16
C121	CERAMIC CAPACITOR	CKPUYY103N16
C122	AXIAL CERAMIC C.	CCPUSL470J50
C123	ELECTR. CAPACITOR	CEAS010M50
C125	ELECTR. CAPACITOR	CEAS4R7M50
C126	ELECTR. CAPACITOR	CEAS100M50
C128, 129	CERAMIC CAPACITOR	CKPUYY103N16
C130, 131	ELECTR. CAPACITOR	CEAS010M50
C132	ELECTR. CAPACITOR	CEASR33M50
C134, 135	CERAMIC CAPACITOR	CKCYB103K50
C136, 137	ELECTR. CAPACITOR	CEAS4R7M50
C142	ELECTR. CAPACITOR	CEAS470ML6
C145	CERAMIC CAPACITOR	CKPUYB221K50
C146, 147	AXIAL CERAMIC C.	CCPUCH150J50
C148	AUDIO FILM CAPACITOR	CFTXA224J50

Mark No.	Description	Parts No.
C149	AUDIO FILM CAPACITOR	CFTXA103J50
C150	ELECTR. CAPACITOR	CEAS330M16
C151	AXIAL CERAMIC CAPACITOR	CKPUYF223Z25
C152	CERAMIC CAPACITOR	CKPUYY103N16
C201	ELECTR. CAPACITOR	CEAS010M50
C231, 232	ELECTR. CAPACITOR	CEAS100M50
C233, 234	CERAMIC CAPACITOR	CCCSL221J50
C235, 236	ELECTR. CAPACITOR	CEAS470M10
C237, 238	MYLAR FILM CAPACITOR	CQMA242J50
C239, 240	MYLAR FILM CAPACITOR	CQMA822K50
C241, 242	ELECTR. CAPACITOR	CEAS2R2M50
C243-246	AXIAL CERAMIC CAPACITOR	CKPUYF103Z25
C247, 248	CERAMIC CAPACITOR	CKCYB331K50
C249	CERAMIC CAPACITOR	CKCYB471K50
C251, 252	ELECTR. CAPACITOR	CEAS2R2M50
C253, 254	ELECTR. CAPACITOR	CEAS4R7M50
C501, 502	ELECTR. CAPACITOR	CEAS2R2M50
C503, 504	CERAMIC CAPACITOR	CKCYB102K50
C505, 506	CERAMIC CAPACITOR	CKDYB681K50
C520	ELECTR. CAPACITOR	CEAS101M16
C521, 522	ELECTR. CAPACITOR	CEAS220M16
C523, 524	CERAMIC CAPACITOR	CCCSL120K500
C525, 526	CERAMIC CAPACITOR	CCCSL050C500
C551-554	CERAMIC CAPACITOR	CCCSL101K500
C561, 562	MYLAR FILM CAPACITOR	CQMA473K50
C601	ELECTROLYTIC CAPACIT	CEAS471M6
C602	AXIAL CERAMIC CAPACITOR	CKPUYF103Z25
C603	ELECTR. CAPACITOR	CEAS101M16
C605	ELECTR. CAPACITOR	CEAS4R7M50
C701, 702	ELECTROLYTIC CAPACIT	ACH1145
C703	ELECTR. CAPACITOR	CEAS101M16
C704	ELECTR. CAPACITOR	CEAS100M50
C705	ELECTR. CAPACITOR	CEAS101M25
C706	ELECTROLYTIC CAPACIT	CEHAQ470M35
C707	CAPACITOR (0.047/5.5)	ACH1135
△ C708	CKA (0.01/AC400V)	ACG1002
C709	CKA (0.01/AC250V)	ACG1005
C710	ELECTROLYTIC CAPACIT	CEHAQ470M10

RESISTORS

R521, 522	CARBON FILM RESISTOR	RD1/4PM562J
R523, 524	CARBON FILM RESISTOR	RD1/4PM104J
△ R527, 528	CARBON FILM RESISTOR	RD1/4PMF680J

Mark No.	Description	Parts No.
△ R535, 536	FUSLIBLE RESISTOR	RFA1/4PS101J
△ R551-554	FUSLIBLE RESISTOR	RFA1/4PS101J
R555-558	CARBON FILM RESISTOR	RD1/4PMF101J
△ R561, 562	RESISTOR (0.33, 5W)	ACN1087
△ R563, 564	CARBON FILM RESISTOR	RD1/4PMF100J
R565, 566	CARBON FILM RESISTOR	RD1/4PMF100J
△ R608	METAL OXIDE RESISTOR	RS2LMF911J
R609	CARBON FILM RESISTOR	RD1/4PM123J
△ R700	METAL OXIDE RESISTOR	RS1PMF562J
R701	CARBON FILM RESISTOR	RD1/4PM302J
△ R703	CARBON FILM RESISTOR	RD1/4PMF2R2J
△ R705	METAL OXIDE RESISTOR	RS2LMF122J
△ R715	METAL OXIDE RESISTOR	RS1LMF151J
△ R721-723	METAL OXIDE RESISTOR	RS2LMF682J
△ R753	CARBON FILM RESISTOR	RD1/4PMFL2R2J
	Other resistors	RD1/8PM□□□J

OTHERS

X101	CRYSTAL RESONATOR (456kHz)	ASS1066
X102	CRYSTAL RESONATOR (7.2MHz)	ASS1005
	ANTENNA TERMINAL 4-P	AKA1009
	PIN JACK 6P	AKB1121
	(PHONO, CD, VCR/LD)	
	PIN JACK 8P	AKB1127
	(TAPE1/DAT, TAPE2 MONITOR)	
	SPEAKER TERMINAL 8-P	AKE-111
	AC OUTLET (1P)	AKP1054
	AM RF TUNING BLOCK	AXY1025
	2 SERIAL F.E. MODULE ASSEMBLY	AXQ1002
	(This assembly has no service part.)	

9k/10k ASSEMBLY (SX-311R/SD, SX-201/SD)

SWITCH

S999	SWITCH	ASE-028
------	--------	---------

8. PANEL FACILITIES

- The illustration shows SX-311R multi-voltage model.

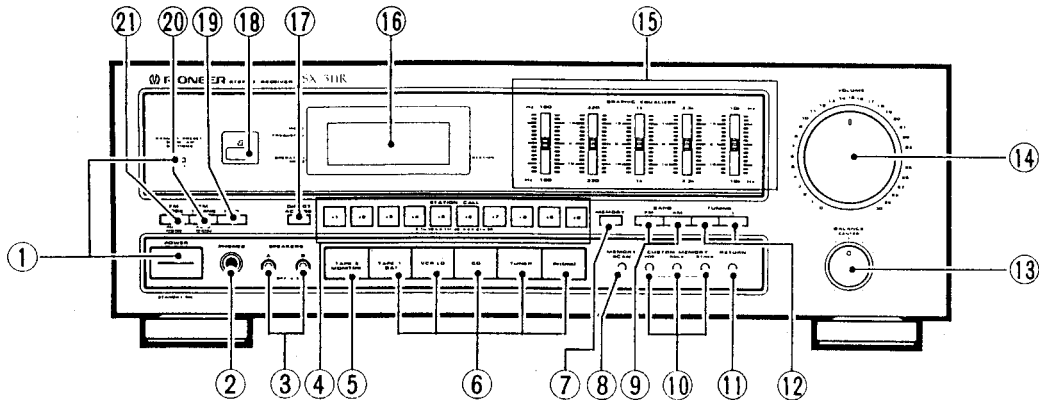

① POWER (STANDBY/ON) switch

(SX-311R, SX-251R)

STANDBY indicator

(SX-311R multi-voltage model only)

This is the switch for electric power.

ON: When set to the ON position, power is supplied and the unit becomes operational.

STANDBY: When set to the STANDBY position, the main power flow is cut and the unit is no longer fully operational. A minute flow of power feeds the unit to maintain operation readiness.

- The accessory remote control unit can also be used to operate STANDBY/ON.

[For SX-311R multi-voltage model]

Even when the power is in STANDBY, the STANDBY indicator remains lit.

NOTE:

When the power is initially turned ON, muting will be applied to prevent sound from being output for approx. 5 seconds.

① POWER (OFF, ON) switch

(SX-301, SX-201)

When this switch is pressed, power is supplied to the unit.

Press the switch again to turn power OFF.

[Timer ON/OFF possible]

When the unit is switched ON, ON/OFF control can be performed by means of the optional timer.

NOTE:

When the power is initially turned ON, muting will be applied to prevent sound from being output for about 5 seconds.

② PHONES jack

Connect the plug on your headphones to this jack. To listen to a program through the headphones, set both SPEAKERS A and B switches to the OFF position.

③ SPEAKERS (OFF, ON) buttons

These are used to select the speaker through which you wish to listen.

A: When the speakers connected to A terminals are in use.

B: When the speakers connected to B terminals are in use.

- Turn both A and B speakers to OFF position when only the headphones are in use.

NOTE:

No sound will be heard through the speakers when both A and B buttons are depressed if only one set of speakers has been connected to either A or B SPEAKERS terminals.

④ STATION CALL buttons

These buttons are used to preset and recall desired broadcasting stations.

⑤ TAPE 2 MONITOR button

Press when listening to tape playback with the cassette deck 2.

⑥ Function buttons

Use to select playback source.

[TAPE 1/DAT] – Press when listening to tape playback with the cassette deck 1 or digital audio tape deck.

[VCR/LD] – Press when listening to programs from a component connected to the VCR/LD terminals.

[CD] – Press when listening to compact disc playback with a CD player.

[TUNER] – Press when listening to AM or FM broadcasts with a tuner.

[PHONO] – Press when listening to record playback on a turntable.

⑦ MEMORY button

When the unit is in the frequency display mode, pressing this button will result in the memorization of the current broadcast band, reception frequency, and FM AUTO/MONO mode.

This button is also used to input custom memory names.

⑧ MEMORY SCAN button

This button is used for both station memory scan and custom memory scan.

⑨ BAND Selector buttons

These buttons are used to select either AM or FM reception.

⑩ CUSTOM MEMORY buttons

Stations can be assigned to STATION CALL buttons according to the genre of material broadcast (POP, ROCK, OTHER). You can recall a particular genre, and scan all the stations of that genre with Memory Scan until you reach the desired one.

⑪ RETURN button

This is helpful during troubleshooting or when no sound is output. Pressing this button returns the receiver to the following settings, the sound level being controlled by VOLUME control.

- TAPE 2 MONITOR OFF
- FUNCTION TUNER
- BAND FM*

* The last FM broadcast you were listening to will be received. When reception is not possible, search begins for frequency that can be received.

NOTE:

If no sound is output after the RETURN button is pressed, make sure that SPEAKERS switches are turned on.

⑫ TUNING buttons (-, +)

+: The FM or AM band is scanned in the direction of increasing frequency.

-: The opposite operation to that of the UP button takes place.

⑬ BALANCE control

Should normally be left in the center position. Adjust balance if the sound is louder from one of the speakers. If the right side is louder, turn toward the L position and if the left side is louder, turn toward the R position.

⑭ VOLUME control

Use to adjust volume level.

⑮ GRAPHIC EQUALIZER controls

The equalizer is divided into five frequency ranges (100 Hz, 330 Hz, 1 kHz, 3.3 kHz, 10 kHz) to tailor music to the individual taste of the listener.

⑯ OPERATION DISPLAY panel

- (a) Indicates the function or frequency by the function switches.
- (b) TUNED indicator
- (c) FM STEREO indicator
- (d) FM MONO indicator
- (e) TUNING AUTO/MANUAL indicator
- (f) DIRECT ACCESS tuning indicator
- (g) CUSTOM MEMORY indicator
- (h) Indicates channel, STATION CALL number or sleep time.
- (i) SEARCH indicator
- (j) SCAN indicator
- (k) MEMORY indicator
- (l) TAPE 2 monitor indicator.

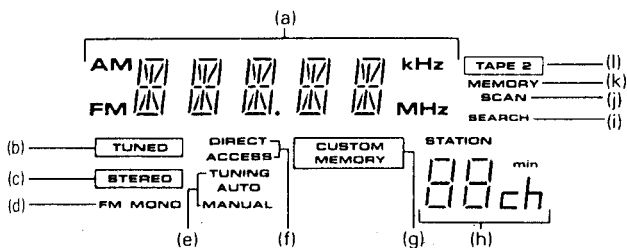

⑰ DIRECT ACCESS tuning button

When this button is pressed, the STATION CALL buttons function as ten-key number buttons for direct input of the desired reception frequency. Press again to cancel this mode.

If the input station falls outside of the receiver's tuning range, the display section will display a message: "UPPER" if the frequency is too high and "LOWER" if it is too low.

⑱ Remote sensor window

(SX-311R, SX-251R models only)

⑲ HITS button

- Works during FM reception.
- If the HITS button is pressed during input of numbers for DIRECT ACCESS tuning, the receiver sets the remaining digits which have not yet been input to "0", searches for the corresponding frequencies, and stops on the first station it finds.
- If the HITS button is pressed at the currently displayed station frequency, the receiver searches up and down the frequency band for the next station (the SEARCH indicator in the display section lights at this time) and stops at the first one it finds.

(FM)

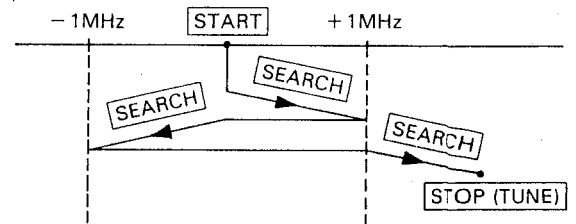

NOTE:

- The system searches for stations within successive 1 MHz ranges for FM. During DIRECT ACCESS tuning, it searches up and down for a station until it reaches the edges of the band. If no receivable station is found within the band range, the receiver returns to the state it was in before the HITS button was pressed.
- If the upper (or lower) frequency limit of the receiver is encountered during HITS operation, the receiver stops searching in that direction but continues to search in the other.

⑳ FM TUNING AUTO/MANU button

Works during FM reception.

Use this button to select either the AUTO mode or the MANUAL mode.

When the "AUTO" indicator is lit, the receiver is in the AUTO mode.

㉑ FM MODE AUTO/MONO selector button

Use to select the auto stereo mode or monaural mode when listening to FM broadcasts. The monaural mode has been selected when the FM MONO indicator is lighted.

Auto stereo mode:

Normally leave in this mode for reception. When a stereo FM broadcast is received, it will be automatically reproduced in stereo sound.

Monaural mode:

When receiving distant stations or stations with weak broadcast signals, the input signal may be weak, thus resulting in increased noise during FM stereo broadcasts. In this event, setting the receiver to the monaural mode will reduce the noise. In this case, however, FM stereo broadcasts will be reproduced in monaural sound.

NOTE:

This button has no effect on reception of AM broadcasts.

SX-311R/SX-301 SX-251R/SX-201

- The illustration shows SX-311R multi-voltage model.

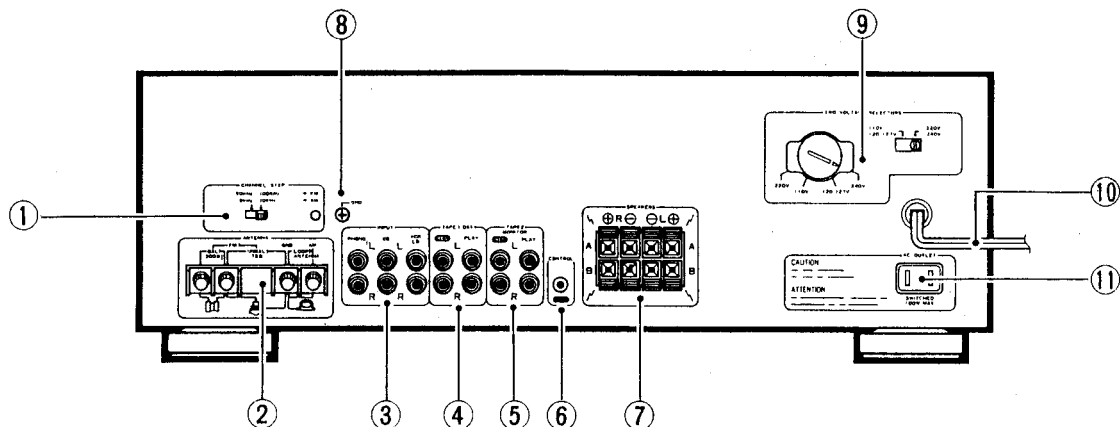

① CHANNEL STEP switch

② FM/AM ANTENNA terminals

Use these antenna terminals for receiving FM and AM broadcasts.

③ INPUT jacks

PHONO Connect to the output cables from a turntable.
 CD Connect to the output jacks of a compact disc player.
 VCR/LD ... Connect to the output jacks of a video cassette recorder or LD player, etc.

④ TAPE 1/DAT jacks

Connect these jacks to the cassette deck or digital audio tape deck.

⑤ TAPE 2 jacks

Connect these jacks to the cassette deck.

⑥ CONTROL OUT jacks (SX-311R, SX-251R only)

Connect this jack to other Pioneer components bearing the  mark when using the remote control of this unit to control the other components.

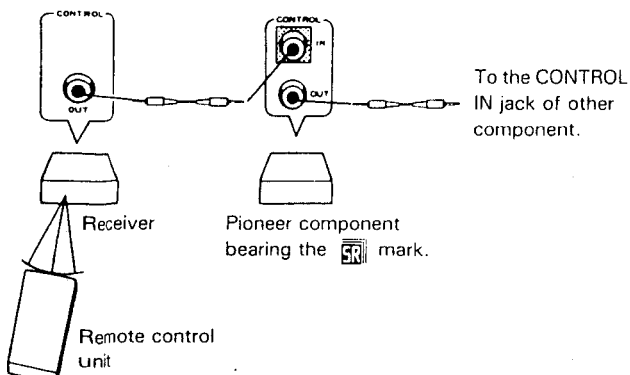

⑦ SPEAKERS terminals

A: Connect to a first set speakers.
 B: Connect to a second set of speakers.

NOTE:

No sound will be heard through the speakers when both A and B buttons are depressed if only one set of speakers has been connected to either A or B SPEAKERS terminals.

⑧ GND terminal

Connect to the ground lead of a turntable.
 Use a screwdriver to connect with the ground terminal.

⑨ VOLTAGE SELECTORS (SX-311R, SX-201 multi-voltage models only)

⑩ Power cord

Connect to AC wall socket.

⑪ AC OUTLET

AC OUTLET

[U.S. and Canadian models] SWITCHED 100 W MAX (0.8 A MAX)

Power supplied through this outlet is turned on and off by the receiver's POWER switch. Electrical power consumption of the connected equipment should not exceed 100 W (0.8 A MAX).

The equipment should be disconnected by removing the mains plug from the wall socket when not in regular use, e.g. when on vacation.

[Multi-voltage model] SWITCHED 100 W MAX

Power supplied through this outlet is turned on and off by the receiver's POWER switch. Electrical power consumption of the connected equipment should not exceed 100 W. The equipment should be disconnected by removing the mains plug from the wall socket when not in regular use, e.g. when on vacation.

CAUTION:
DO NOT CONNECT MONITOR OR TV SET.

NOTE:

Do not connect appliances with high power consumption such as heaters, irons, or television sets to the AC OUTLET, in order to avoid overheating or fire risk.
 This can cause the receiver to malfunction.