

# DUAL 500 SERIES TWO POWER AMPLIFIER

## *Service Manual*

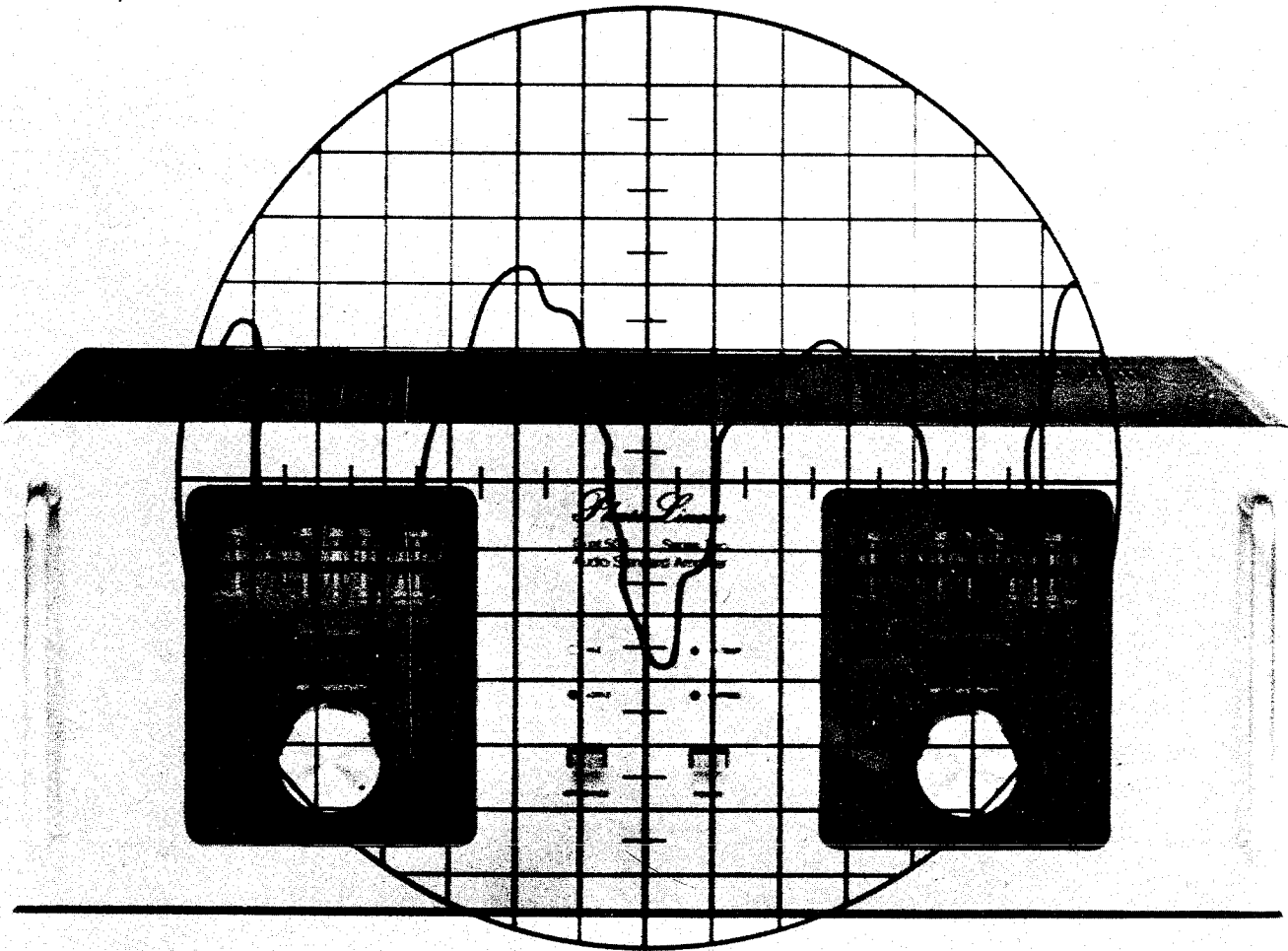

*Phase Linear*  
THE POWERFUL DIFFERENCE

Phase Linear Service Department  
20121 48th Ave. West  
Lynnwood, WA 98036  
Tel. (206) 774-8848  
(206) 774-3571

#1078

revised 5/81

DUAL 500 SERIES TWO POWER AMPLIFIER

SERVICE MANUAL

CONTENTS

1-0.	Technical Specifications .....	4
2-0.	Schematics and Diagrams .....	5
3-0.	Circuit Descriptions .....	12
4-0.	Disassembly Procedure .....	15
5-0.	Test Procedure .....	20
6-0.	Troubleshooting Guide .....	23
7-0.	Parts List .....	32
8-0.	Service Bulletins and Supplements ..	33

\*\*\*\*\*CAUTION\*\*\*\*\*

THIS MANUAL IS INTENDED FOR USE ONLY BY QUALIFIED TECHNICAL SERVICE PERSONNEL. HAZARDOUS VOLTAGES MAY BE ENCOUNTERED IN THE TEST AND SERVICING OF THE DUAL 500. USE EXTREME CAUTION: READ ALL INSTRUCTIONS CAREFULLY

## 1.0. Technical Specifications

### 1-1.1. Performance Specifications

RATED OUTPUT: 505 watts per channel minimum power RMS into 8 ohms from 20Hz to 20K Hz with no more than 0.09% total harmonic distortion.

POWER OUTPUT FOR PROFESSIONAL USE: 800 watts per channel minimum power RMS into 4 ohms at 1000Hz with no more than 0.09% total harmonic distortion.

TYPICAL TOTAL HARMONIC DISTORTION: 0.009% at rated power into 8 ohms @ 1K Hz.

INTERMODULATION DISTORTION (60Hz:7K Hz = 4:1): Less than 0.09% at rated power into either 4 or 8 ohms.

FREQUENCY RESPONSE: 12Hz to 40K Hz +0/-1dB.

SIGNAL-TO-NOISE RATIO (IHF A-CURVE): Better than 110dB below 505 watts into 8 ohms.

RESIDUAL NOISE (IHF A-CURVE): 120 microvolts.

DAMPING FACTOR (8 OHMS): Greater than 1000 @ 1K Hz.

SLEW RATE: Better than 20 volts/microsecond.

RISE TIME (SMALL SIGNAL): Less than 4.0 microseconds.

PHASE RESPONSE: 0 degrees at 20Hz; -18 degrees at 20K Hz.

SENSITIVITY: 1.5 volts RMS for 505 watts into 8 ohms.

LOAD IMPEDANCE: Greater than 4 ohms in high impedance mode.

INPUT IMPEDANCE: 33K ohms minimum at full clockwise rotation of level control.

- DISPLAYS: A. A peak responding 3½-inch sequential light emitting diode (LED) display is provided for each channel. The display is calibrated to indicate output voltage and power levels on a logarithmic scale, and 0dB corresponding to rated power output (505 watts into 8 ohms). The dynamic range of the display is greater than 40dB; it responds to peak output voltage levels with very fast rise time but relatively slow decay time. Amplifier clipping or overload is indicated by a flashing right-hand portion of the display. Flashing will continue for approximately 2 seconds after an overload condition. LED's are provided to indicate the following:
- B. High/low impedance mode of operation.
  - C. Amplifier turn-off due to excessive high temperatures.
  - D. Activation of the high frequency overload circuit.

CONTROLS: Independent front panel level controls for each channel, pushbutton power switch, and push-button load impedance selector.

- PROTECTION:
- A. Output transistor protection - electronic limiters together with power supply fuses prevent excursions into the unsafe operating region, regardless of load conditions.
  - B. High frequency overload protection - high frequency input signals greater than 10K Hz of sufficient amplitude to produce clipping will be attenuated to prevent common mode conduction of output transistors.
  - C. Speaker protection - the amplifier does not provide speaker protection from excessive high-power audio signals. External fusing of the speaker is highly recommended. An electronically activated relay disconnects the amplifier's output to the speakers -
    - 1. for approximately five seconds after turn-on.
    - 2. immediately after turn-off.
    - 3. in the presence of DC output voltage or high-power subsonic signals.
    - 4. if operating temperature exceeds 90°C.
  - D. Thermal protection - the amplifier is convection cooled with automatic switchover to forced air cooling provided by a self-contained fan when unit temperature exceeds 58°C. The speakers will be automatically disconnected from the amplifier's output if operating temperature exceeds 90°C to prevent thermal breakdown.

#### 1-1.2. General Specifications

POWER CONSUMPTION: 1800 watts (16 amps) maximum at rated power output.

DIMENSIONS: 19"W x 7"H x 15"D (48.3cm x 17.8cm x 38.1cm).

SHIPPING WEIGHT: 70 pounds (32kg).

#### 2-0. Schematics and Diagrams.

Diagram 2-1. Main Schematic.

Diagram 2-2. Layout, Main PCB PL32.

Diagram 2-3. X-ray view of PL32, from foil side.

Diagram 2-4. Layout, Display PCB PL33.

Diagram 2-5. X-ray view of PL33, from foil side.

Diagram 2-6. Interconnect schematic.

Diagram 2-7. Block diagram.

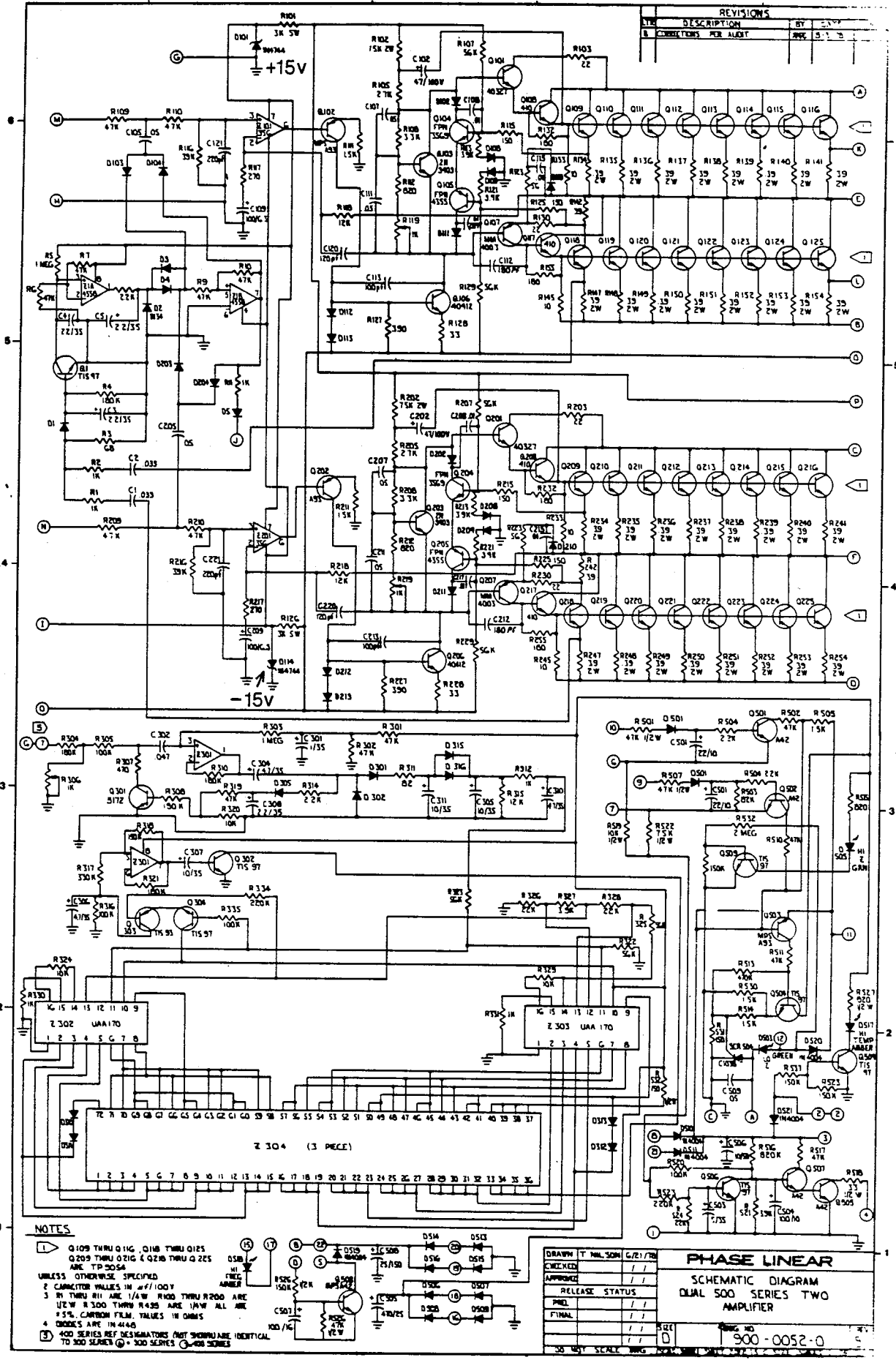

**NOTES**

- 1 Q109 THRU Q116, Q118 THRU Q125  
Q209 THRU Q216 & Q218 THRU Q 225  
ARE TP-2054
- UNLESS OTHERWISE SPECIFIED
- 2 CAPACITOR VALUES IN  $\mu$ F / OOV
- 3 R1 THRU R11 ARE 1/4W R100 THRU R200 ARE  
1/2W R300 THRU R400 ARE 1/4W ALL ARE  
5% CARBON FILM VALUES IN OHMS
- 4 DIMENSIONS ARE IN INCHES
- 5 400 SERIES REF DESIGNATORS (NOT SHOWN) ARE IDENTICAL  
TO 300 SERIES (A) = 300 SERIES (B) = 400 SERIES

DRAWN BY	T. MILSON	DATE	6/21/70
CHECKED BY			
APPROVED BY			
RELEASE STATUS			
PHASE			
FINAL			
SIZE	D	FIG. NO.	900-0052-0
SCALE			

**PHASE LINEAR**  
SCHEMATIC DIAGRAM  
DIAL 500 SERIES TWO  
AMPLIFIER

Diagram 2-1. Main Schematic

REVISIONS		
LTN	DESCRIPTION	BY DATE
C	ADDED C112 & Z12 REMOVED UNUSED PADS & LANDS	TDN 1/21
D	ZONE B11B4 R112 R1212 WAS 680A	TDN 3/9/78
E	CORRECTIONS PER AUDIT	TDN B/3/8

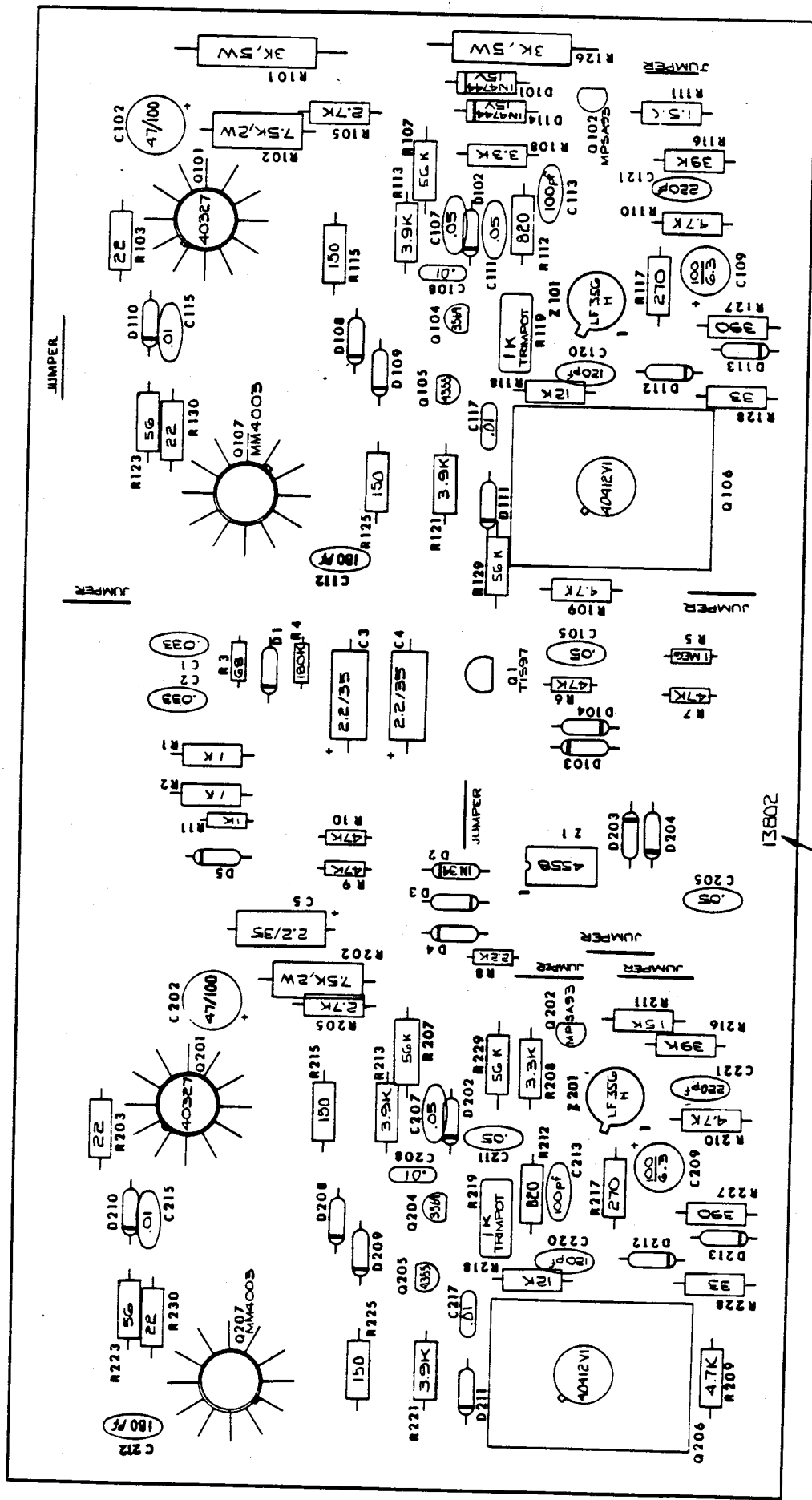

NOTES:  
 1. ALL DIODES IN 4148, UNLESS SPECIFIED OTHERWISE.  
 2. DATE CODE: 13802

Diagram 2-2. Layout, Main PCB PL32.

- Blue (input) —
- Black (input) —
- Purple —
- Brown (bias xstr) —
- Yellow —
- Black (PCB gnd) —
- Grey —
- Orange —
- Brown —
- Black (bias xstr) —
- Blue —
- Red (bias xstr) —
- Green/black —
- Red (B+) —

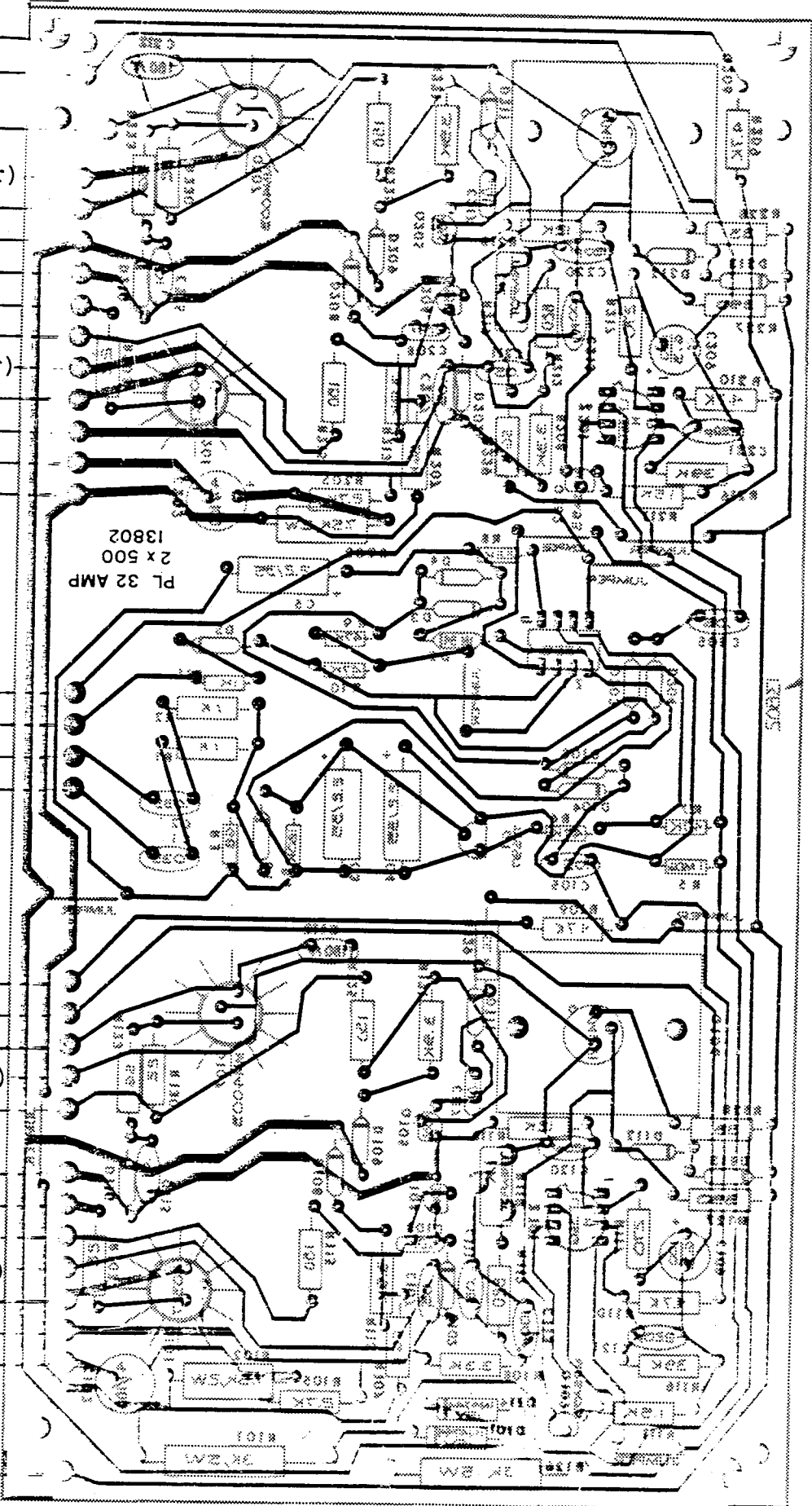

- Blue (LED) —
- Red (LED) —
- Red/white —
- Red/white —

- Blue (input) —
- Black (input) —
- Purple —
- Brown (bias xstr) —
- Yellow —
- Grey —
- Orange —
- Brown —
- Black (bias xstr) —
- Blue —
- Red (bias xstr) —
- Green/black —
- Black (B-) —

Diagram 2-3. X-ray view of PL32, from foil side.

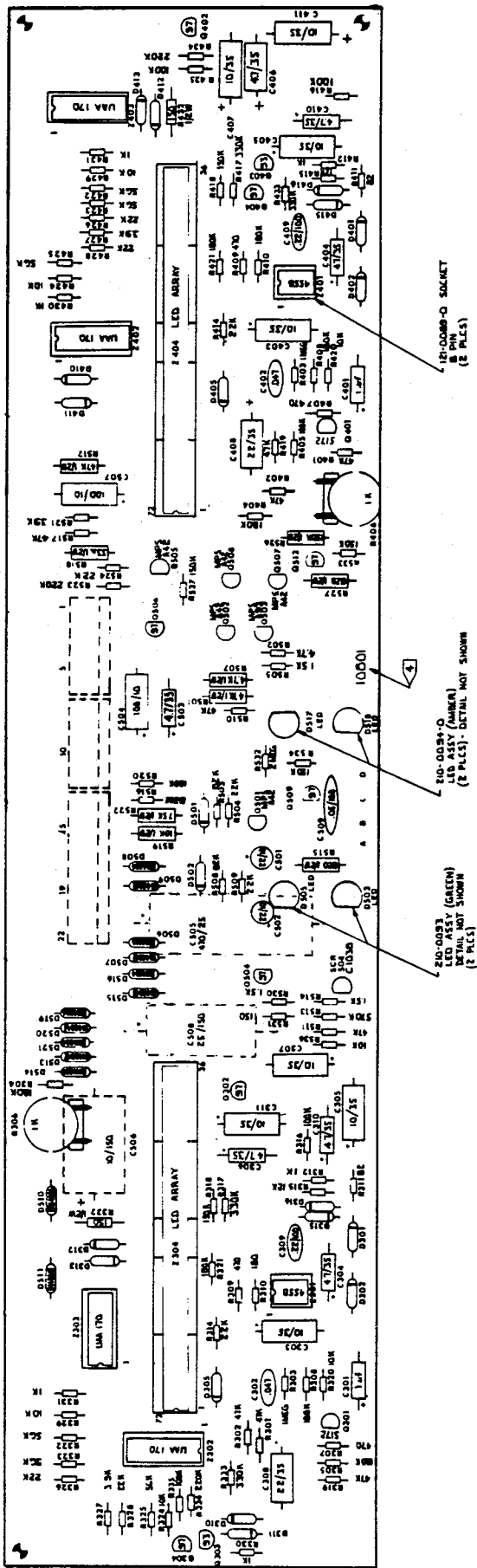

PL 33  
PCB ASSY

NOTES

- 1 ALL DIODES IN4148 UNLESS OTHERWISE SPECIFIED.
- 2 ALL RESISTORS 1/4W 5% CARBON FILM, VALUES IN OHMS, UNLESS OTHERWISE SPECIFIED.
- 3 ALL TRANSISTORS INSTALLED 3B MAX HEIGHT ABOVE PCB

Diagram 2-4. Layout, Display PCB PL33.

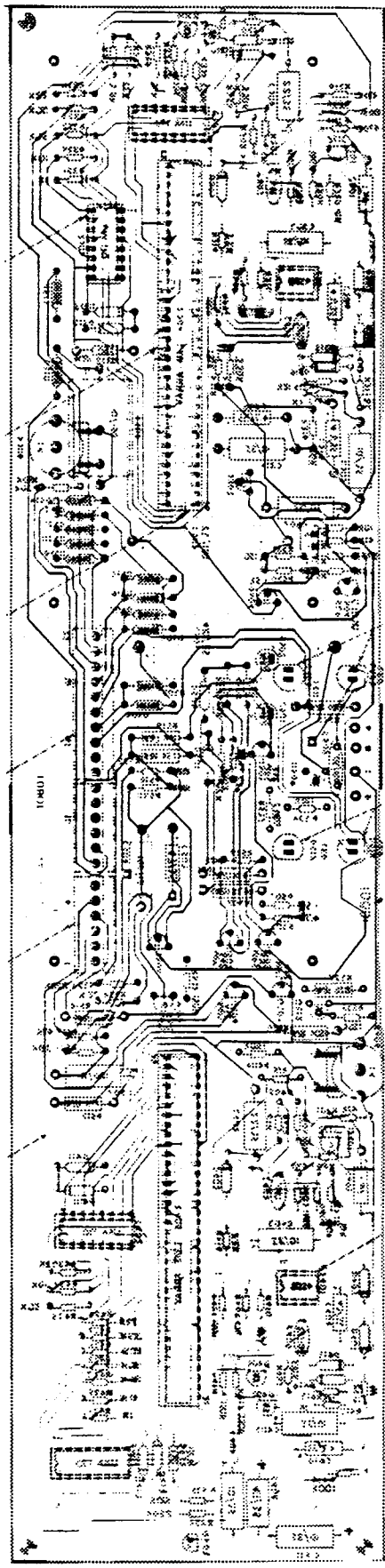

Diagram 2-5. X-ray view of PL33, from foil side.



# DUAL 500 BLOCK DIAGRAM

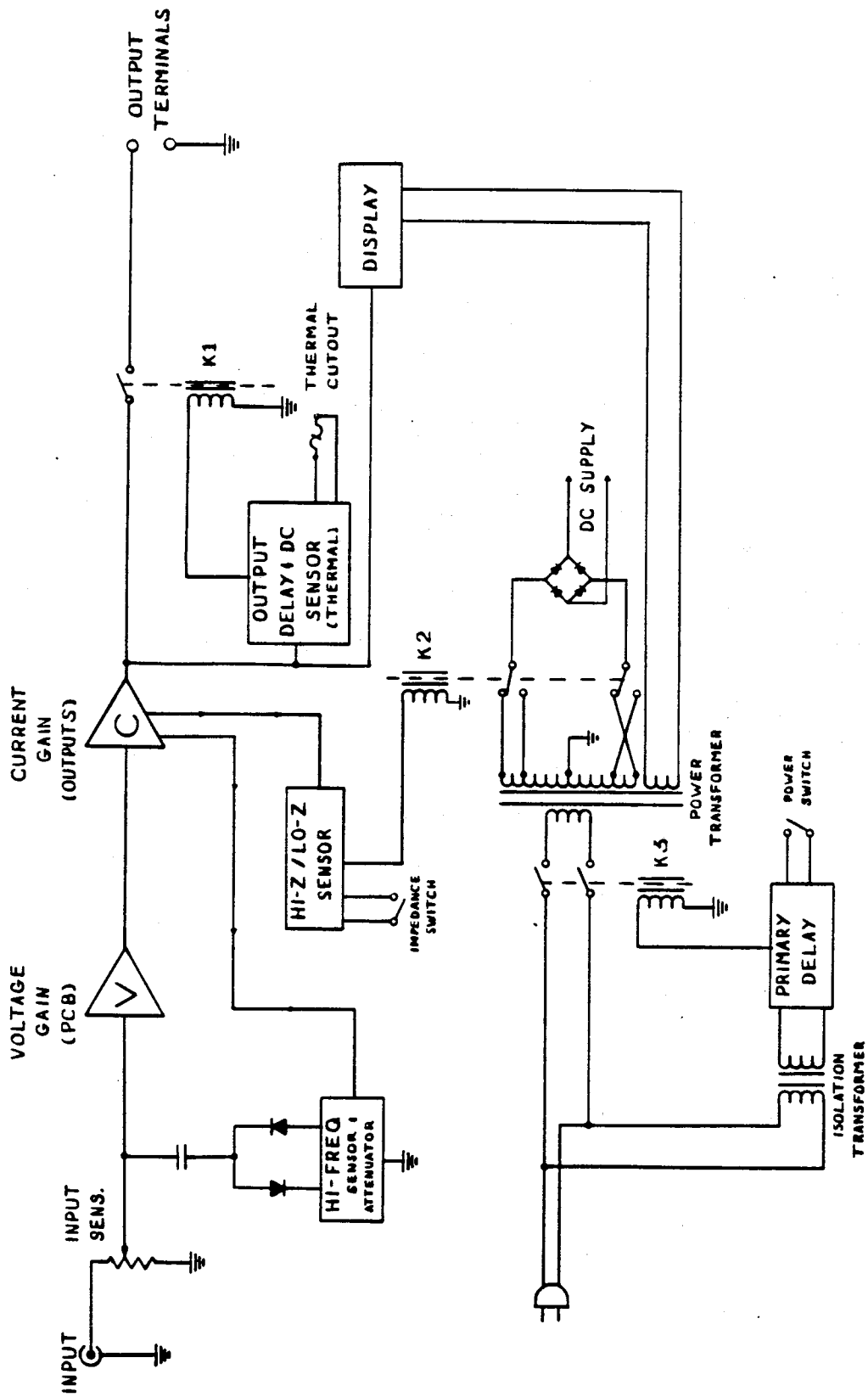

Diagram 2-7. Block diagram.

### 3-0. Dual 500II Circuit Descriptions.

- 3-1. Power Amplifier. The Phase Linear Dual 500 consists of two independent direct coupled linear power amplifiers combined to form a single, dual channel unit capable of extremely high power output. Please refer to the schematic diagram for the following circuit description of the individual power amplifier.

The low level input stage employs a wideband low noise FET input integrated circuit operational amplifier (Op Amp) to provide high open loop voltage gain for minimum distortion. The input signal is applied to the noninverting input of the Op Amp while the inverting input receives a portion of the final output voltage forming a negative feedback loop. A transistor functioning as a voltage level shifter couples the output signal of the Op Amp to a common emitter amplifier. The common emitter amplifier stage, biased for class A operation, is capable of swinging the full power supply voltage of 240 volts, providing the final voltage gain of the amplifier. The output stage forms a unity voltage gain buffer, capable of delivering the required current.

A bootstrap arrangement is used to provide a high impedance load for the common emitter stage and at the same time increases the amount of drive current available to the positive predriver transistor allowing symmetrical saturation. Control of the amplifier idle current is accomplished with a transistorized biasing circuit (Vbe multiplier) which regulates the bias conditions of the predriver, driver and output transistors. The bias regulator transistor is mounted on the output stage heat sink assembly to achieve proper thermal tracking and prevents the possibility of thermal runaway.

The output stage of each channel employs 18 high current, high voltage silicon power transistors arranged in a quasi-complementary format and biased for true class B operation. The required bias current is carried by the driver transistors only, resulting in very high circuit efficiency. In this design, the driver and predriver transistors serve to provide current amplification of the output signal from the common emitter stage to a level required by the parallel connected output transistors.

Voltage and current levels of the output transistors are monitored continuously during amplifier operation by the built-in, dual-slope protection circuit. The protection circuit consists of two transistors, one operates when the amplifier output is positive and the other operates when the amplifier output is negative. If the voltage and current levels in the output transistors become excessive,

the protection transistors will conduct to divert drive current entering the predriver transistors; thereby limiting the current flow in the output stage to a safe level.

If the amplifier clips with high frequency signals and common mode conduction of the output transistors occurs, the high frequency overload protection circuit is activated. The protection circuit consists of a diode detector, three stages of amplification and a high frequency attenuator. The diode detector monitors the output stage of the amplifier and generates a DC voltage if common mode conduction occurs. This DC voltage is then amplified by one transistor and two Op Amps to turn on the attenuator located at the input of the amplifier. Consequently, high frequency input signals are momentarily attenuated to stop the clipping and the output stage is taken out of common mode conduction.

- 3-2. LED Drive. The LED drive gets its input from the speaker relay output. R304 and R306 form an input voltage divider with R306 serving as an input sensitivity adjustment for the LED display. Z301, D305 and Q301 form a compressor/rectifier circuit which is necessary for the LED drive chips (UAAL70). Part of the output of Z301 is rectified by D305 and fed back to the base of Q301 which acts as a variable shunt resistance at the input of Z301 thereby compressing the amplifier output voltage. D301 and D302 form a half-wave rectifier which converts the compressed AC output of the amplifier into a compressed DC voltage suitable for driving the LED drive ICs. This compressed DC voltage varies from 0 V (ground) to 5 VDC. The circuit is designed so that 5 VDC corresponds to full output voltage of the amplifier.
- 3-3. Clipping Indicator. If the amplifier output is clipped, more than 5 VDC is generated. This causes zener diode D303 (5.1 V) to become forward biased and activates the clipping indicator. The other half of Z301 forms a monostable multivibrator. The output of Z301 is normally low until the DC voltage at pin 5 (+ input) exceeds about 1 volt. When this happens, the output of Z301 swings high, temporarily forward biasing Q302 and causing the last four display LEDs to turn on. The length of time the LEDs flash is determined by C306 and the rate of flashing is determined by the R-C time constant of R321 and C309.
- 3-4. Delayed turn-on. When the on/off switch is depressed, voltage from the isolation supply (C+) is applied through R526 to the base of Q508. When the charge across C507 is sufficient to turn on Q508, the relay coil is activated and the contacts close thus turning on the main (A+, B+) power supplies.

3-5. Output Relay. The output relay closes when the charge through R516 across C504 is sufficient to turn on Q505 and Q507. There are two protection circuits associated with the speaker relay:

3-5.1. DC/subsonic sensing. The relay will remain closed until excessive DC or subsonic (less than or equal to 10Hz) voltage charges up R-C combination, R523 and C503, causing Q506 to conduct and short across C504. When this happens, Q505 and Q507 will turn off thus opening the speaker relay.

3-5.2. High temperature sensing. The two thermal cutouts on the outside edge of the heatsinks will open when heatsink temperature reaches the 85-90° C range. When this happens, collector current from Q507 through the relay coil will switch off thus opening the relay. At the same time the base of Q512 will be pulled up thus turning on Q512 and the Hi-Temp LED, D517.

3-6. High/Low Z Circuit. Output current is sensed across two output emitter resistors (one per channel). The voltage across these emitter resistors is rectified by D501 and D502 and stored in capacitors C501 and C502. When it is sufficient to turn on Q501 and Q502 (indicating excessive output current and/or a low impedance load), Q503 and Q504 also turn on thus pulling up (positive) the gate of SCR504. This causes SCR504 to conduct which closes the Lo Z relay contacts and turns on the Lo Z LED (D503). The Hi Z mode can be restored by pressing the Hi/Lo Z switch in and then out again. This temporarily shorts the anode of SCR504 to ground causing it to turn off.

Q501 and Q502 are normally off thus turning on Q509 and the Hi Z LED.

3-7. High Frequency Overload. High level (clipping), high frequency (above 10K Hz) output can cause the output stage to go into common mode conduction due to the finite turn on/off time of the output transistors. This condition is prevented by the High Frequency Overload circuit. Output voltage is applied to C1-R1 and C2-R2 which is rectified by D1 and applied to C3. When the charge on C3 is sufficient to turn on Q1, a low voltage is applied to comparator Z1 causing its output to flip from positive to negative. This voltage is limited by D2, then inverted by Z1B. These complementary DC voltages are applied to D103 and D104 causing them to conduct, and thus shunting input voltage through C105. This limits high frequency inputs to a safe region.

## DUAL 500

### 4-0. DISASSEMBLY PROCEDURE

#### CONTENTS

- 4-1. Output stage and main PCB inspection/repair
- 4-2. Front panel disassembly
- 4-3. Front panel re-assembly
- 4-4. Relay and power supply access

CAUTION: Before disassembling the Dual 500, unplug the power cord, push the power switch to the ON position, wait 5 seconds, then switch the power back OFF. This is necessary to remove any hazardous charge which might still remain in the power supply capacitors.

#### 4-1. OUTPUT STAGE AND MAIN PCB INSPECTION/REPAIR

- 4-1.1. Place unit as shown, upside down with heatsinks forward, and remove the seven phillips screws farthest to the rear on the bottom cover.

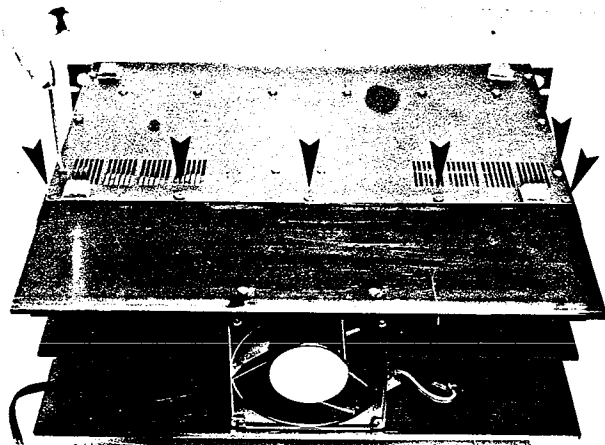

4-1.2. Turn the unit right side up, heatsinks forward, align it such that the four heat-sink retainer screws are in a vertical line with the edge of the table or bench, as shown.

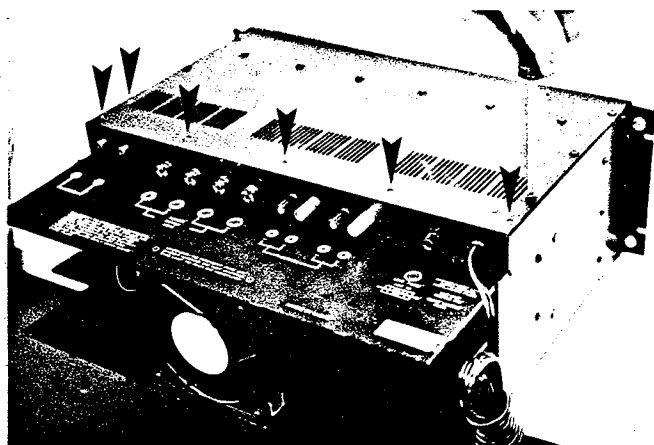

4-1.3. Remove the 7 phillips screws from the top cover closest to the heatsink.

4-1.4. LOOSEN ONLY--DO NOT REMOVE all four heatsink re- tainer screws, about two turns.

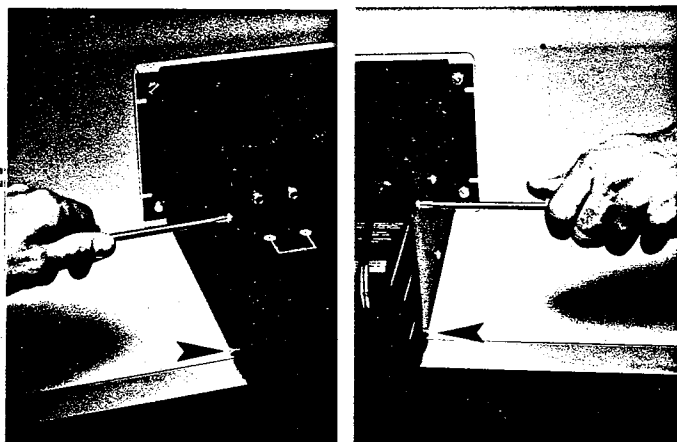

4-1.5. While holding the heat-sink assembly firmly, re- move the two upper heat- sink retainer screws. With these screws removed, the heatsink is now free to rotate downwards, ex- posing the main PCB and allowing removal of the transistor covers.

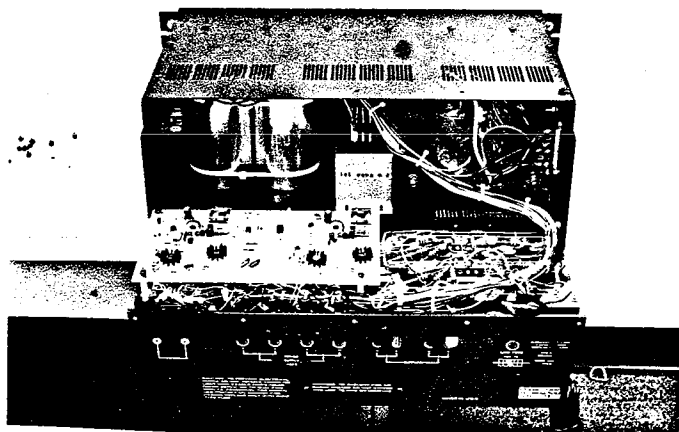
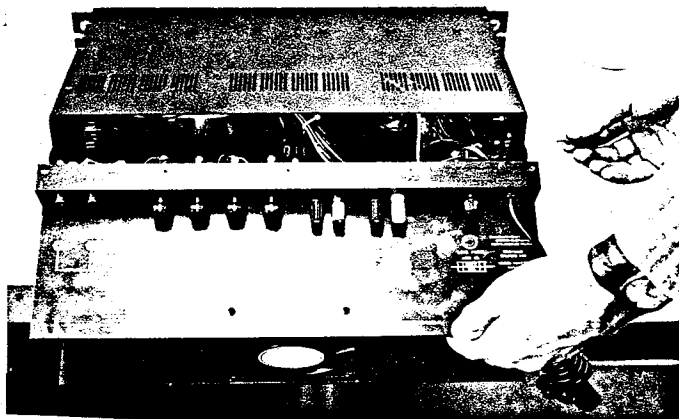

4-1.6. Unscrew the four main PCB retainer bolts and rotate the PCB forward for access to the foil side and output wiring.

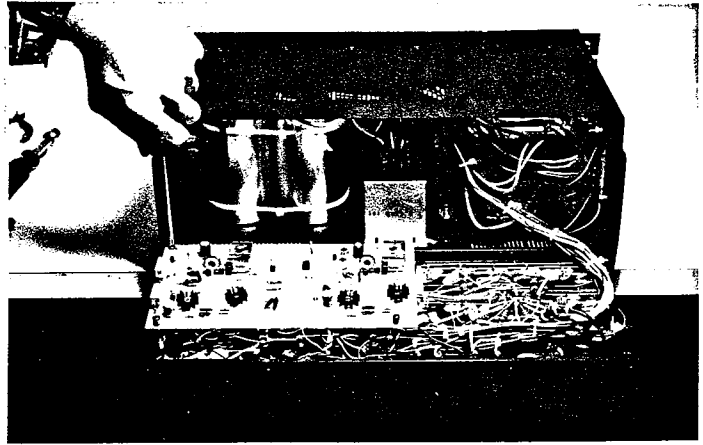

**CAUTION:** While testing or working on the unit with the heatsink rotated downward, be careful not to short any PCB components or jumpers to the heatsink when working on the main PCB.

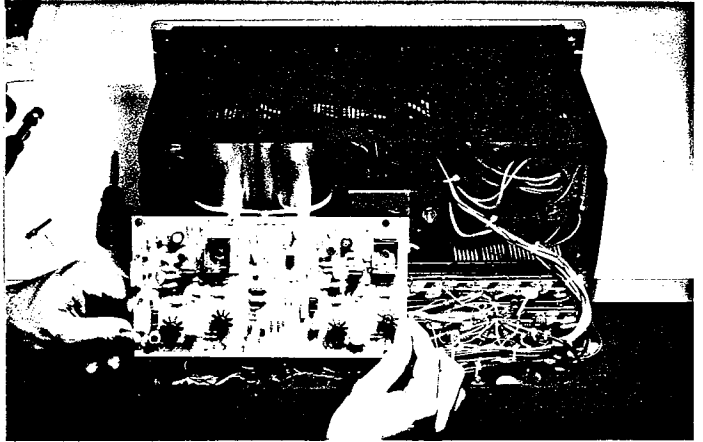

4-1.7. To re-assemble, reverse the above procedure.

**CAUTION:** Be sure that all of the transistor covers<sup>1</sup> and the fan cord grommet<sup>2</sup> are properly positioned and that all wires are clear before rotating the heatsink assembly upward into position. **DO NOT FORCE THE HEATSINK INTO POSITION.** Check for pinched wires and clearance under the top cover.

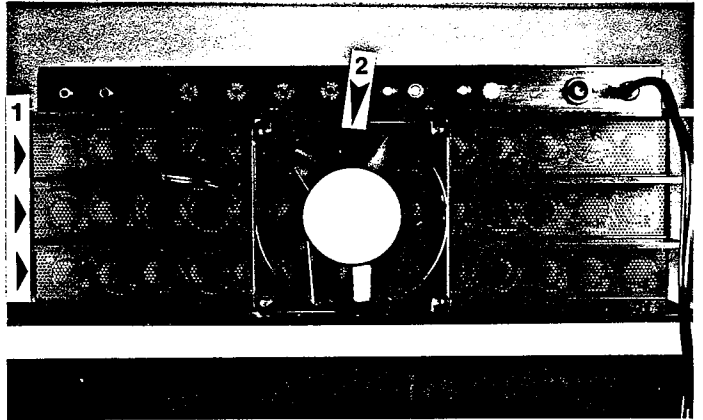

## 4-2. FRONT PANEL DISASSEMBLY

4-2.1. Position the unit right side up, front panel forward, and at least 6 inches back from the edge of the bench. Remove all four handle screws; set handles and ferrules aside.



4-2.2. Slide front panel forward to clear switch buttons and set panel aside.

4-2.3. Remove all six sub-front panel retainer screws, located just behind the chassis ears.

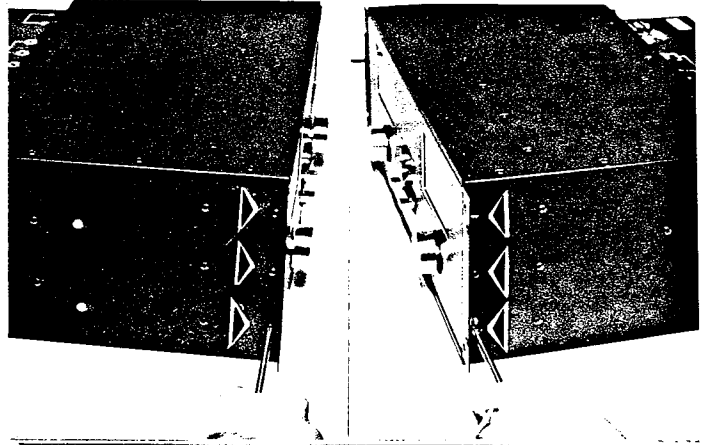

4-2.4. Pull the sub-front assembly forward out of the chassis, unplug the three wire harness connectors and place the assembly face down on a non-abrasive surface.

**CAUTION:** When unplugging the wire harness connectors DO NOT PULL BY MEANS OF THE WIRES, as these may pull out from the connector. Grasp the nylon connector itself and pull firmly.

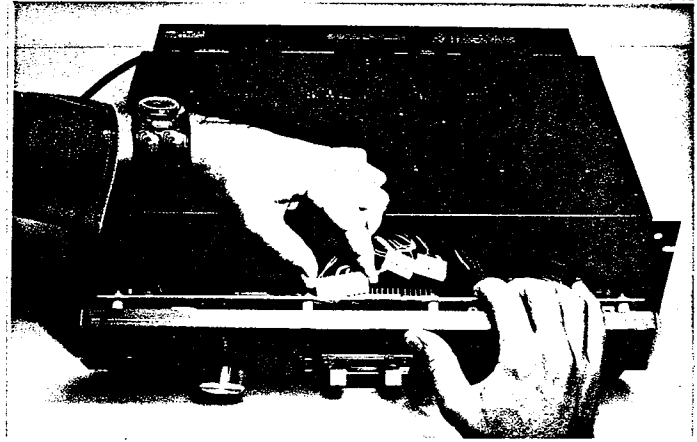

4-2.5. Remove the 8 front panel PCB retainer nuts and fiber washers and lift the PCB upward for access to the component side of the board. DO NOT STRAIN THE WIRES TO THE SWITCH ASSEMBLY.

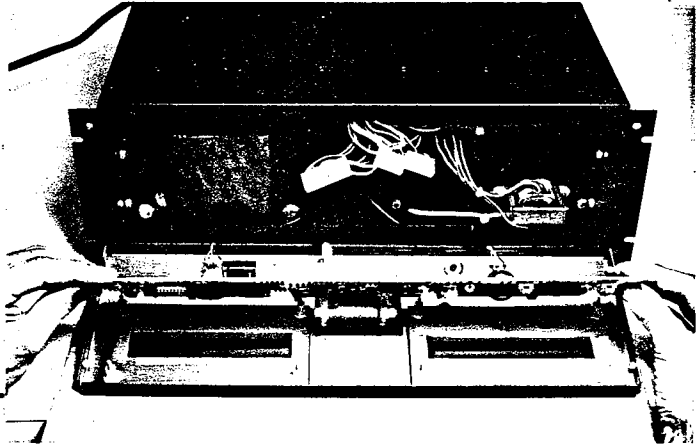

#### 4-3. FRONT PANEL RE-ASSEMBLY

4-3.1. Position the front panel PCB onto the retainer bolts and replace the fiber washers and nuts. Tighten nuts firmly.

**CAUTION:** Be sure all fiber washers are in place before tightening nuts.

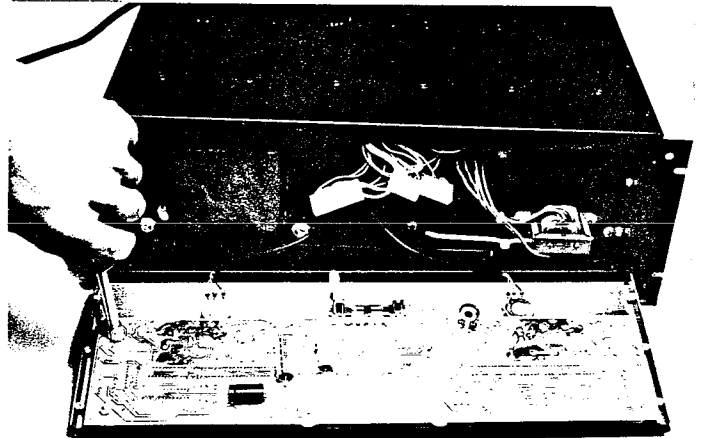

4-3.2. Plug in the wire harness connectors as shown, position the sub-front assembly in the chassis and insert but DO NOT TIGHTEN the six sub-front retainer screws.

4-3.3. Slide the front panel in place over the LEDs and switch buttons. Position handles with ferrules and secure loosely in place with handle screws and washers.

CAUTION: Be sure that all four LEDs are lined up with the front panel holes before tightening the handle screws, otherwise these LEDs might be damaged.

4-3.4. Insert a phillips screwdriver into one of the upper sub-front retainer screws and then pull forward on the tip of the screwdriver firmly so that the sub-front panel is pulled snugly against the back of the front panel, as shown. Again be sure that the four LEDs are aligned in the holes. While holding thus, tighten the screw firmly. Repeat this procedure for the other upper, lower, then middle retainer screws.

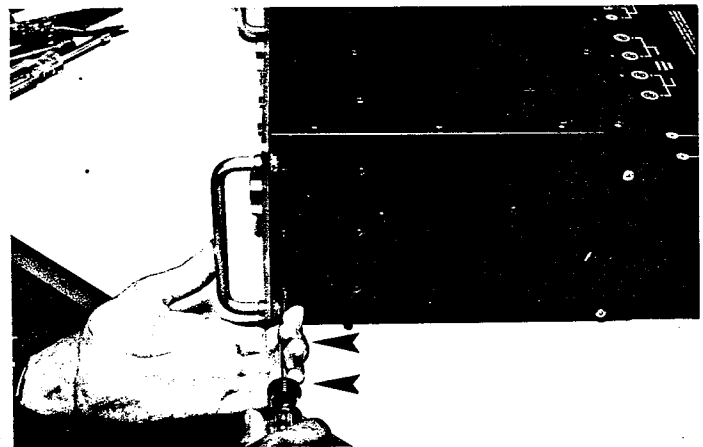
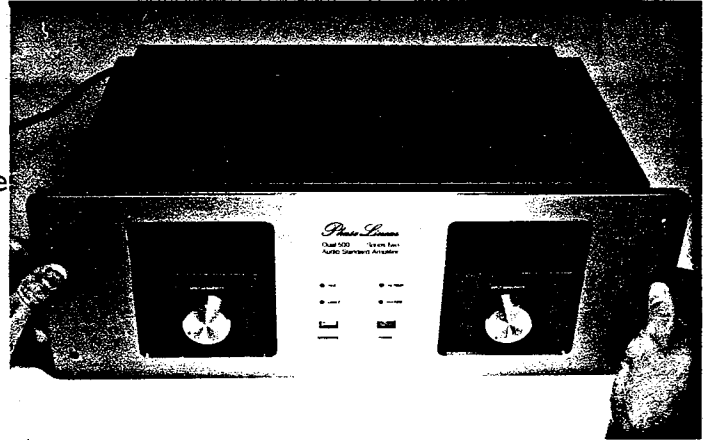
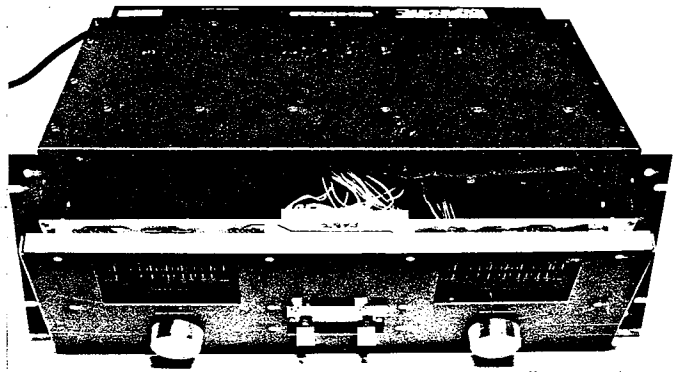

#### 4-4. RELAY & POWER SUPPLY ACCESS

4-4.1. Remove the top cover plate, 17 phillips screws.

CAUTION: When replacing the top cover screws, position and turn each slowly counterclockwise until the screw drops into the former threads. Then turn it clockwise and tighten. Avoid crossthreading the rearmost screws as these may break off before fully tightened.

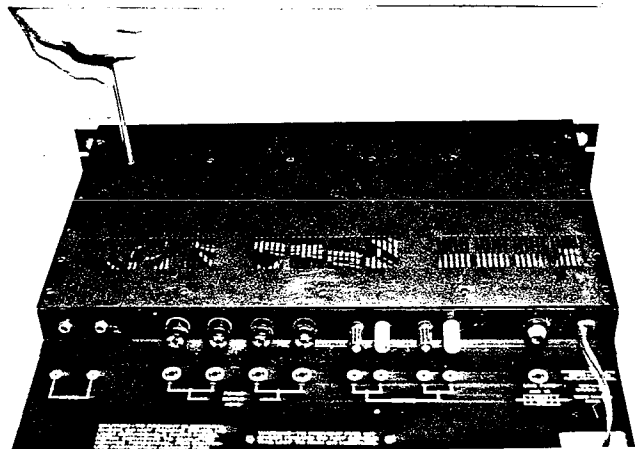

## 5.0 TEST PROCEDURE

### CONTENTS

- 5-1. Power supply
- 5-2. Energizing the unit
- 5-3. Output signal--without load
- 5-4. Output with 8 ohm load
- 5-5. Hi-Z and Lo-Z modes
- 5-6. Distortion
- 5-7. Offset
- 5-8. Short circuit test
- 5-9. Output relay test
- 5-10. Display

#### Necessary Equipment:

Low distortion audio generator  
VOM or DVM  
High Impedance scope  
500 watt dummy load, 8 & 4 ohms (250 watt short term)

- 5-1. Power supply. Before plugging in the AC line cord on the Dual 500, check all fuses: verify AGX-8 ONLY for the supply fuses and ABC 15 only for the line fuse. (ABC 8 for 220V)

CAUTION: If any fuse is discovered blown, do not energize the unit, even after replacing the blown fuse(s). Follow the procedure in section 6-1 to properly energize the unit without causing possible further damage to the output stage.

- 5-2. Energizing the unit. With the Dual 500 power switch in the OFF position, plug the AC line cord into a variable line transformer or AC outlet governed by no less than a 20 amp circuit breaker. If a variable transformer is used, turn it up to the specified line voltage (117 or 230 VAC). Depress the Dual 500 power switch to the ON position and verify that either the Lo-Z or Hi-Z LED indicator on the front panel lights up. NOTE: The amber Hi-Temp and/or Hi-Freq LEDs may light up briefly, then turn off after the unit is fully energized.
- 5-3. Output signal--without load. Verify that the Dual 500 is in the Hi-Z mode. Monitor the left channel output with the scope and AC voltmeter--DO NOT CONNECT ANY OTHER LOAD TO THE OUTPUTS AT THIS TIME. Drive only the left channel input with a 2K Hz sine wave until the output wave form is well into clipping. Verify that the clipping is symmetrical. Turn down the input and repeat the above with the right channel.
- 5-4. Output with 8 ohm load. Connect an 8 ohm 500 watt (250 watt short term) load resistor to the right channel output terminals and monitor the right channel output. Apply a 2K Hz signal to the right channel input and verify at least 64 VRMS output before clipping.

NOTE: Prolonged clipping (more that a second or two) may cause the Dual 500 to automatically switch to the Lo-Z mode; the amplifier must be in the Hi-Z mode to meet the 64 VRMS spec. Depress the Impedance switch twice to return to the Hi-Z mode if the amplifier automatically switches to Lo-Z.

Repeat the above at 20 Hz, 200 Hz, and 20K Hz with the right and then left channel.

- 5-5. Hi-Z and Lo-Z modes. Drive BOTH channels of the Dual 500 simultaneously into clipping at 20K Hz with a load and verify that the amplifier drops into the Lo-Z mode automatically: the front panel Lo-Z LED should be lit, and the output signal should appear more severely clipped due to the lower supply voltage in the Lo-Z mode. While in the Lo-Z mode, drive the right channel to clipping into a 4 ohm load and verify at least 40 VRMS before clipping. Verify at least 38 VRMS before clipping into a 2 ohm load. Repeat these for the left channel.

- 5-6. Distortion. Monitor the left channel output with a THD analyzer; verify that the 8 ohm load is connected to the left output terminals. Drive the left channel output to 64 VRMS and verify a THD of 0.09% or less. Repeat this with right channel.
- NOTE: It may be necessary to use the high filter on the THD analyzer if it is so equipped. Use the above procedure to verify IM distortion of 0.09% or less.
- 5-7. Offset. Measure the output of the left and right channels with a DC voltmeter and verify less than  $\pm 10$  mV DC of offset.
- 5-8. Short Circuit Test. Drive the right channel with 200Hz signal to an output level of 64 VRMS. Now short the right channel output terminals with a jumper wire for 2 to 3 seconds. In the shorted mode the Dual 500 will draw at least 11 amps from the AC line. Remove the shorting jumper and verify that the amplifier resumes normal operation. Repeat the above for the left channel.
- 5-9. Output Relay Test. Drive the left channel into clipping with a 1 Hz to 10 Hz signal (with or without a load) and verify that the output signal is removed almost immediately; this should be accompanied by a distinct clicking sound as the output relay opens. Turn down or remove the input signal and verify that the output relay closes in two to four seconds, restoring signal to the output terminals. Repeat the above with the right channel.
- 5-10. Display. Remove all connections from the outputs except the scope, using this to monitor the output of either channel. Drive BOTH inputs with a 60 Hz signal: slowly increase the input level while observing both LED arrays. Verify that these track within 3 segments of each other. Drive both channels to clipping and verify that the last four segments on the right end of each array flash and remain flashing for 1 to 3 seconds after the input is turned down. The display clipping network should respond to 63 VRMS output,  $\pm 2$  db. This completes the Dual 500 test procedure.

## 6-0. TROUBLESHOOTING GUIDE

### CONTENTS

- 6-0. Troubleshooting guide
- 6-1. Power supply malfunction
- 6-2. Unit will not energize properly
- 6-3. Output malfunction--no load
- 6-4. Output malfunction into a load
- 6-5. Malfunction of Hi-Z/Lo-Z circuit
- 6-6. Excessive distortion/bias adjustment
- 6-7. Excessive offset
- 6-8. Protection circuit malfunction
- 6-9. Output relay malfunction
- 6-10. Display malfunction
- 6-11. Hi-Freq Overload Circuit Malfunction

NOTE: Most transistors and diodes in the Dual 500 can be checked in circuit using an ohmmeter on the RX1, RX10 or 2K ohm scale. With the Dual 500 power switch OFF, measure the forward-biased resistance of the particular diode or transistor junction and verify a reading of 400 to 700 ohms on a typical DVM for a good device. Actual readings on good devices will vary from meter to meter, and some meters do not have sufficient test voltage to turn on a semiconductor. Nevertheless the shorted or open device is usually revealed quickly using this method.

CAUTION: BEFORE MAKING ANY MEASUREMENTS INTERNAL TO THE DUAL 500, UNLESS OTHERWISE SPECIFIED BE SURE THAT THE LINE CORD IS UNPLUGGED AND THE POWER SUPPLY CAPACITORS ARE DISCHARGED--WAIT AT LEAST 5 MINUTES AFTER UNPLUGGING THE AMPLIFIER TO ENSURE THAT THESE CAPACITORS ARE DISCHARGED. USE EXTREME CAUTION WHEN TAKING ANY MEASUREMENTS INTERNAL TO THE DUAL 500 WITH POWER ON--HAZARDOUS VOLTAGES ABOVE 100 VOLTS ARE PRESENT. ONLY QUALIFIED PERSONNEL WITH PROPERLY INSULATED AND PROTECTED EQUIPMENT SHOULD ATTEMPT SERVICING OF THE DUAL 500 WITH POWER ON.

## 6-1. POWER SUPPLY MALFUNCTION

- 6-1.1. Blown supply fuse. If any of the supply fuses are found blown, there is a high probability that one or more of the output transistors is defective, especially if the blown fuse appears blackened or silvered (indicating large current surge).

CAUTION: Do not replace the fuse(s) and energize the unit at this point since this may cause further damage to the output stage. First perform the following test to check for defective output transistors:

- 6-1.2. Checking for shorted outputs. Be sure that the AC line cord of the Dual 500 is UNPLUGGED, then follow the disassembly procedure steps 4-1 through 4-6. Place the negative probe of an ohmmeter (set on the RX1, RX10 or 2K ohm scale) on the collector buss wire of one bank of output transistors. Touch the positive probe to any one of the output emitters in that bank. If any of the transistors in that bank is shorted, the meter will display a very low reading, usually less than an ohm.

If none of the outputs are shorted, the meter will display a typical reading for a forward biased diode (since measurement is essentially across flyback diodes D115 and D116), usually 400 to 700 ohms depending on the meter in use. Repeat the above for each remaining bank of transistors. Refer to 6-1.3. for isolation of a defective output transistor.

- 6-1.3. Isolating defective outputs: To isolate the defective output(s) in a bank which indicates a short, switch the ohmmeter to the lowest scale (RX1 or 200 ohm) and touch the positive probe to each output emitter in that bank, leaving the negative probe connected to the collector buss wire as in 6-1.2. One or two of the readings will be significantly lower than the rest, which indicates that that particular output transistor is shorted. Replace the defective output(s) and repeat the above until no short is indicated.

IMPORTANT: WHENEVER ANY OUTPUT TRANSISTOR HAS BEEN REPLACED IT IS NECESSARY TO PERFORM STEP 6-1.4. TO VERIFY PROPER CURRENT SHARING OF ALL OUTPUT TRANSISTORS.

6-1.4. Current sharing test: This test is necessary to verify that ALL outputs are operating properly, ensuring a permanent repair. Although the amplifier will probably meet all specs without all outputs operational, increased current loading of the remaining outputs will result in a significant reduction in reliability.

- a). With an 8 ohm load connected to the output terminals of the left channel, drive the left input with a 200 Hz signal to obtain 63 V RMS output (unit must be in the Hi-Z mode at this time). Now switch the unit into the Lo-Z mode and verify that the output signal appears well into clipping.
- b). Using a DC voltmeter, measure the voltage drop across one emitter resistor in each output bank. Verify that there is between 140 and 170 millivolts DC across these resistors.
- c). If any readings do not fall within the above typical spec, measure ALL of the emitter resistor voltages in that bank. Replace any transistor whose emitter resistor reading varies more than +10% from the average reading in that bank, after verifying that the emitter resistor itself is not damaged. Be sure to re-check any bank of outputs in which a transistor has been replaced.

## 6-2. UNIT WILL NOT ENERGIZE PROPERLY

6-2.1. Unit blows circuit breaker at turn-on: The large, short-term in-rush current of the Dual 500 power supply may trip a circuit breaker under certain conditions. For proper turn-on of the Dual 500, be sure that:  
-there are no other current loads on the breaker line in addition to the Dual 500.  
-the circuit breaker is at least 20 amp.

6-2.2. Power supply relay will not switch in:

- a). Replace line fuse ABC 15.
- b). Check the relay drive circuit on the display PCB: Q505, Q506, Q507 and associated circuitry. With the power switch on, there should be 110 VDC on the collector of Q507.
- c). Check for proper isolation supply voltage: 100 VDC across C508. If there is insufficient or no voltage present, check D513 thru D516; also pull the isolation transformer secondary and verify approx. 85 VAC secondary output.
- d). Check for shorted main filter capacitors.
- e). Check on/off switch continuity; check line cord continuity.
- f). Verify proper wiring to coil of relay K3.

6-2.3. Bypassing power supply and output relays:

- a). Unplug the AC line cord of the Dual 500 and press the power switch to the ON position.
- b). Remove the top cover plate (17 phillips screws).
- c). Using a pair of needle-nose pliers, grasp the connector joining the purple wire to the coil of relay K1 and unplug this from the relay pin.

CAUTION: Do not unplug the connector by pulling the wire, as this will cause the wire to break from the connector. Grasp the connector itself firmly and pull upward with a rocking motion. After the connector is free, insert the loose connector into the wire bundle to keep it from touching any metal parts in the amplifier.

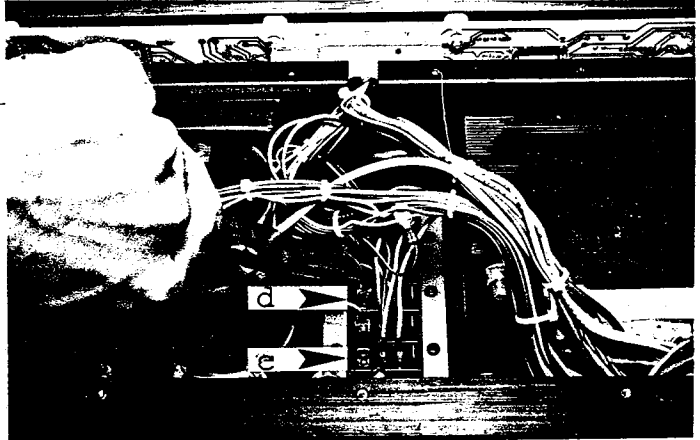
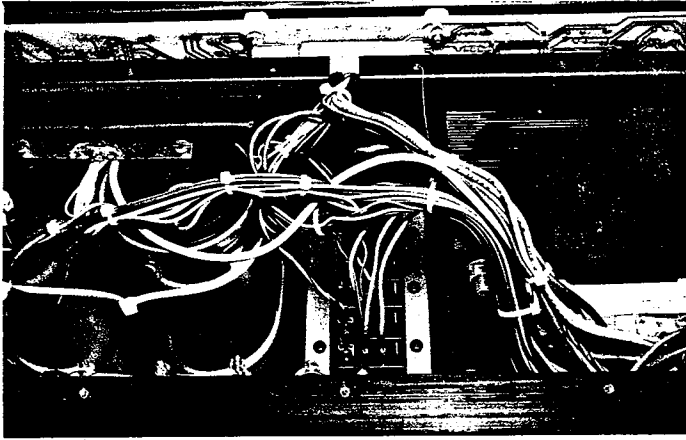

- d). Repeat step C above with the connector joining the orange wire to the coil of relay K3 .
- e). Move the two black wire connectors on K3 and the two gray wire connectors on K1 to the outer (normally closed) pins on each respective relay, as shown. Both relays are now bypassed.

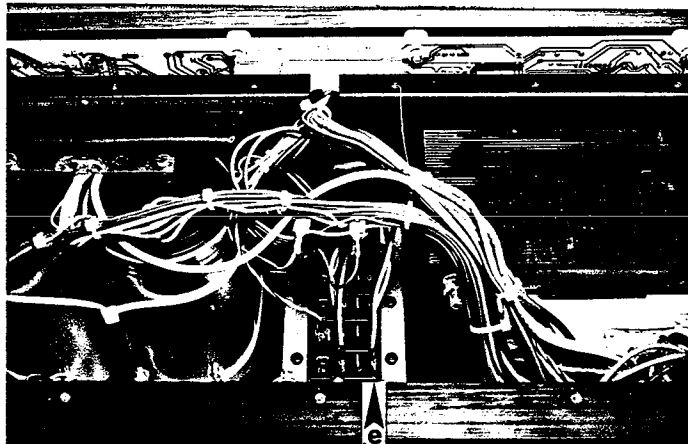

- f). With D500 power switch ON, plug the AC line cord into a variable line transformer set at 0 VAC. Slowly turn the transformer up to no more than 20 VAC while observing the output of each channel of the Dual 500 with a scope. If the unit does not show a proper output signal when operated according to step 5-3, and/or draws large amounts of line current when voltage is first applied, turn the variable transformer off and trouble-shoot according to step 6-3.
- g). After verifying proper operation of both channels up to 117 VAC, unplug the Dual 500 line cord and reverse the above procedure to return the relay network to normal operation.

### 6-3. OUTPUT MALFUNCTION--NO LOAD

- 6-3.1. No output, one or both channels: If one or both channels fail to demonstrate any output signal during the test in 5-3, it is recommended that the unit be turned off immediately and all further troubleshooting be continued only after bypassing the power supply and output relays as outlined in step 6-2.3. Fully energizing the unit in certain failure modes may cause further damage and longer repair times.
  - a). Offset: If the output shows excessive DC offset this may prevent output relay from closing when normally wired.
    - check collector of Q106 for no more than .66 VDC; check all semiconductors in circuit (6-0)
    - check for proper ground on both inputs
    - replace Z101,
    - replace Q102, then Q106
  - b). No output:
    - check supply fuses--refer to 6-1.1. thru 6-1.3.
  - c). Excessive current drawn when voltage applied to the line cord:
    - check the bias transistors carefully; replace if necessary. If the unit ceases to draw excess current when the bias transistors are shorted from collector to emitter, then replace the bias transistors.
    - check outputs and output drivers (6-1.2,3.).
- 6-3.2. Asymmetrical clipping:
  - a). Verify matched power supply readings at the filter capacitors in the main power supply, + 120 VDC in Hi-Z mode, + 85 VDC in Lo-Z. There should be no greater than 2 volts difference between positive and negative supply reading.
  - b). see 6-3.3.

- c). Disconnect one end of diodes D102 and D111 in the protection circuit and repeat the test. If the problem is now removed, replace D102, D111, Q104 and Q105 as necessary.

6-3.3. Truncated or asymmetrical output:

- a). Possible faulty protection circuit: disconnect one end of diodes D102 and D111 and repeat the test. If the problem is now removed, check and replace D102, D111, Q104 and Q105 as necessary.
- b). Possible defective predriver or output driver; check Q101, Q107, Q117 and Q108.
- c). Possible defective Class A stage; check Q106, D112, and D113.

6-3.4. Oscillations:

- a). Check RC network located at the output terminals; replace if doubtful.
- b). Install 180 pf capacitors from base to collector on predrivers Q101 and Q107, ONLY AS NECESSARY. These may already have been installed at the factory.
- c). Replace predriver Q101, Q107 as necessary.
- d). Replace output drivers Q108 and Q117 as necessary.
- e). Check output transistor insulators: if these are the rubber self-lubricated type, there is a possibility of parasitic oscillations caused by output transistor casing biting through the insulator as a result of thermal cycling or overtightening. It is recommended that if this situation exists that the insulators be replaced with the mica type lubricated with thermal compound.
- f) if oscillations (bursts) occur just before rated output at low test frequencies, be sure that line voltage at the Dual 500 line plug is 120 VAC.

NOTE: Several ferrite beads are positioned in the output stage buss wiring. These are carefully placed at the factory for maximum high frequency stability--it is recommended that these beads NOT BE ALTERED IN THE SLIGHTEST AMOUNT.

6-4. OUTPUT MALFUNCTION INTO A LOAD

6-4.1. Unit will not deliver 64 VRMS into 8 ohm load:

- a). Check for line or variac voltage sag; voltage at the Dual 500 line plug must be at least 117 VAC when delivering full output.
- b). Possible defective output transistor or driver; perform step 6-1.4.

- 6-4.2. Unit will not meet spec at certain frequency:  
a). Check to be sure unit is in Hi-Z mode.  
b). Drive only one input at a time for testing at 20K Hz.  
c). Verify proper line voltage at Dual 500 line plug.
- 6-4.3. Asymmetrical clipping (or loss of half of wave form):  
a). Check protection circuit as outlined in step 6-3.3.  
b). Check for balanced power supply voltage at the main filter capacitors while driving a load. If voltages differ by more than 2 volts, replace the capacitor which reads low.

#### 6-5. MALFUNCTION OF HI-Z/LO-Z CIRCUIT

- 6-5.1. Unit will not drop into Lo-Z:  
a). Replace SCR504, D503.  
b). Check wiring to coil of relay K2.
- 6-5.2. Unit will not stay in Hi-Z mode with 8 ohm load.  
a). Verify that R505 is 1.5K.  
b). Check Q504.

#### 6-6. EXCESSIVE DISTORTION

- 6-6.1. Improper bias setting. Check and adjust as follows:  
a). Allow at least 5 minutes warm-up time; perform step 5-4 to accelerate warm-up.  
b). Remove all input and output connections, then measure the DC voltage drop across R133 or R145 located in the output stage.  
c). Verify a reading of no less than 0.30 VDC and no greater than 0.40 VDC. Adjust R119 as necessary.
- 6-6.2. THD analyzer adjustments:  
a). Activate the 80K Hz filter on the analyzer if it is so equipped and repeat THD measurement.  
b). Examine test bench grounding system for possible ground loops. Ground the analyzer directly to the Dual 500 output ground, not to the load, scope or meter grounds. Use 16 gauge wire for output ground system.

#### 6-7. EXCESSIVE OFFSET

- a). Replace Z101.  
b). Verify +15 VDC  $\pm$  10% across D101; replace if necessary.  
c). Verify -15 VDC  $\pm$  10% across D114; replace if necessary.  
d). Replace Q102.

- e). Replace C109.
- f). Verify proper input ground connection to output ground on both channels. If one channel does not show good ground, install a jumper wire from channel A input ground to channel B input ground.
- g). Isolate the protection circuit as described in 6-3.3a.

## 6-8. PROTECTION CIRCUIT MALFUNCTION

- 6-8.1. Supply fuses open when amplifier is shorted:  
This indicates that the protection circuit is not shunting drive current properly.
  - a). Check Q104, Q105, D102, D111, and D108, D109.
  - b). Check R134, R142, Q109 and Q118 in the output stage.
  - c). Perform step 6-1.4. to verify that all output transistors are functioning properly.

## 6-9. OUTPUT RELAY MALFUNCTION

- 6-9.1. Output relay will not open with low frequency signal:
  - a). Check Q505, Q506, Q507 and associated circuitry.
  - b). Check continuity of wiring from front panel connector to coil of relay K1.
- 6-9.2. Output relay opens prematurely or erratically:
  - a). Check for excessive output offset.
  - b). Replace C503, C504, Q506.
- 6-9.3. Output relay does not close when unit is energized:
  - a). Check Q505, Q506, Q507 and associated circuitry.
  - b). Check for defective output as outlined in step 6-1.2. and 6-1.3.
  - c). Excessive output offset--see step 6-7.

## 6-10. DISPLAY MALFUNCTION

- 6-10.1. -0 dB segment does not meet  $63 \text{ VRMS} \pm 2\text{dB}$  spec:
  - a). Adjust R306 .
- Clipping indicator flashes prematurely (before all segments are lit):
  - a). Replace zener diode D303, D403.
- Clipping indicator does not flash at all:
  - a). Replace D303, D403 and/or Q301, Q401.
- Channels do not track within spec:
  - a). Verify that Q301 is MPS5172; replace if necessary.
  - b). Replace Q301, Q401, D311-D313, D411-D413.

-Twelve-segment array not working:

- a). defective array chip--replace array
- b). Replace Z302.

-One or more individual LED segments not lighting:

- a). Be sure that array is plugged firmly into the socket, wiggle and press down into socket to ensure good contact of all pins.
- b). Defective array; replace array.

-Entire array network not operating:

- a). Verify +12 VDC across C505.
- b). Replace Z302, Z301.

-Three segments do not go off with input removed:

- a). Check and replace as necessary D310, D311, D312 and D314.
- b). Increase C301 to 5 mF.

6-11. High Frequency Overload circuit malfunction.

6-11.1. Hi-Freq indicator LED stays lit.

- a). Check PCB supply at D101 and D114: verify that the positive voltage is at least 0.2 VDC greater than the negative voltage. Replace D101 and D114 as necessary, or exchange these.
- b). Replace Z1, Q1, D1 through D4 as necessary.

7-0. PARTS LIST

Transistors:		Potentiometers:	
TP9054	126-0073-0	100K Log (input)	129-0005-0
66546 (RCA410)	126-0016-0	1K trim	129-0073-0
40412V1	126-0005-0	5K trim	129-0001-0
40327	126-0007-0	Switches:	
MM4003	126-0006-0	Thermal cutout	129-0021-0
MPS A93	126-0028-0	Thermal cut-in	129-0054-0
MPS A42	126-0052-0	2-Sta Push Button	129-0055-0
TIS 97	126-0020-0	15A Relay	129-0053-0
TIS 93	126-0009-0	Fan	129-0036-0
MPS 5172	126-0010-0	Resistors:	
3569	126-0044-0	3K 5w	128-0378-0
4355	126-0045-0	10/3w	128-0356-0
Integrated Circuits:		10/2w	128-0369-0
LF356	126-0051-0	7.5K/2w	128-0366-0
4558	126-0038-0	.39/2w	128-0365-0
UAA170	126-0048-0	Front Panel Accessories:	
LF351	126-0114-0	Knob, 1.5"	142-0038-0
Diodes:		Handle	142-0029-0
S25A20 Bridge	126-0001-0	Handle Ferrule	143-0015-0
1N4148	126-0002-0	Display Glass	141-0072-0
1N4004	126-0003-0	Display Bezel	141-0118-0
1N34	126-0021-0	Display Gasket	141-0119-0
1N4744 (15V)	126-0064-0	Metalwork:	
1N752 (5.6V)	126-0049-0	Front Panel	220-0032-0
C103B (SCR)	126-0047-0	Sub-front Panel	220-0033-0
LED, Amber	126-0065-0	Sub-front, inner	141-0074-0
LED, Green	126-0066-0	Display Face Panel	220-0031-0
LED Array	126-0050-0	Side panel (L)	141-0114-0
Capacitors:		Side panel (R)	141-0113-0
13,000/125V elect	127-0103-0	Top Cover	141-0076-0
470/25V elect	127-0102-0	Bottom Cover	141-0077-0
100/10V elect	127-0022-0	Heatsink	220-0034-0
47/35V elect	127-0032-0	Transistor cover,	
22/10V elect	127-0078-0	1-piece	141-0131-0
20/150V elect	127-0110-0	Transistor cover,	
5/35V elect	127-0037-0	2-piece	141-0142-0
2.2/35V elect	127-0068-0	Circuit Boards:	
.22/100V myl	127-0028-0	PL32 Driver PCB	210-0144-0
.047/100V myl	127-0058-0	PL33 Display PCB	210-0146-0
.033/100V myl	127-0025-0	Note: When ordering replacement	
.01/100V myl	127-0063-0	parts, please specify MODEL and	
.01/100V cer	127-0005-0	SERIAL NUMBER of the unit.	
.05/25V cer	127-0007-0		
Transformers:			
Power	125-0028-0		
Isolation	125-0029-0		

USE ONLY REPLACEMENT PARTS ISSUED OR AUTHORIZED BY THE PHASE LINEAR FACTORY SERVICE DEPARTMENT. ANY USE OF UNAUTHORIZED PARTS WILL RESULT IN INVALIDATION OF THE EXPRESS PHASE LINEAR WARRANTY.

8-0. Service Bulletins and Supplements.

This section of the Dual 500 Service Manual is reserved for the inclusion of any service bulletins, troubleshooting or other supplements which apply to the Dual 500.



Phase Linear

20121 - 48th Avenue West, LYNNWOOD, WASHINGTON 98036 U.S.A. Telephone: (206) 774-3571

## SERVICE BULLETIN

**IMPORTANT!! ALL PHASE LINEAR PRODUCT SERVICING PERSONNEL PLEASE READ...**

**SUBJECT:** Models 400 Series, 700 Series, and D-500 amplifier output transistors and output driver transistors.

Since Phase Linear amplifiers began production several years ago we have incorporated several different types of output transistors and a few variations on output driver transistors. *Only* those which we have used in the past have been tested and approved by our engineering department for use in Phase Linear amplifiers. It is very important that **ALL OUTPUT TRANSISTORS USED IN PHASE LINEAR AMPLIFIERS BE THE SAME IN EACH CHANNEL**, that is, they must match by make and device number. Mixing output transistors in the same channel will adversely affect performance, reliability, and/or thermal stability. Therefore when replacing defective output transistors be sure to use only the same make and number used in that particular channel.

The following is a list of output transistors used in the past and their disposition. *Only* these devices have been approved for use in any of the 400 or 700 series amplifiers. Do not attempt to cross-reference these devices to another type of output transistor (2N, Sylvania ECG, etc.) since in the past the use of these devices has resulted in various kinds of amplifier malfunctions or direct failures. Also notice that the model Series Two D-500 uses *only one type* of output transistor (TP9054).

TP9054 (Motorola) - used in some production runs of Series Two model 400II and 700II. This is a higher voltage (and subsequently more expensive) device than the other output transistors. The model D-500 uses TP9054's *exclusively*; no other output transistor should be used in this amplifier. TP9054 is our own number stamped on Motorola MJ15024 devices. If MJ15024's are available locally they may be mixed with TP9054's in the same channel; this is one of *only two* exceptions to the mixed output rule (see XPL909).

XPL909 (Delco) - used in original 400's and 700's to the present. Some early XPL909's were marked PL909 and should not be confused with the Fairchild PL909 transistor. Delco PL909's are marked with *blue* ink and should be considered as XPL909 when ordering replacements. XPL909 is our own number stamped on selected Delco DTS411 devices. If DTS411's are available locally they may be mixed with XPL909's in the same channel. This is one of *only two* exceptions to the mixed output rule (see TP9054).

F

PL909 or FPL909 (Fairchild) - notice the 'F' above PL909. This is how the number appears on the device. Do not confuse Fairchild PL909's with early Delco PL909's. All Fairchild PL909's are marked with *black* ink and should be considered as FPL909 when ordering replacements.

XPL910 (Delco) - these are power Darlington devices and are no longer used in production. Be sure not to confuse or mix these with XPL909's since the design markings on both devices are identical.

1B05 (RCA) - this is RCA's number and these should be available locally. They are no longer used in production.

MJ15011 (Motorola) - this is Motorola's number and these should be available locally. They are no longer used in production.

SE230 (Sensitron) - may be found only on very early model 400's. This is Sensitron's number and these may be available locally.

PL909A (Motorola) - notice the 'A' suffix. These may be found only on very early model 400's and possibly an early 700. These were found to have inconsistent reliability traits and should *all* be replaced in the amplifier whether good or defective. See exchange policy below.

2SD555 (NEC) - was never used in production runs of 400 or 700 series but is a suitable replacement transistor and is slightly more expensive than other outputs. These should be available locally.

*Exchange Policy.* Since some of the approved output devices have been dropped from our production runs and others are no longer stocked it may be necessary to replace all of the output transistors in one channel of an amplifier if duplicate replacements are not available.

We will be glad to exchange good (non-defective) output transistors for what we have currently available in stock at no charge *providing that* there be included with the transistors returned a note or letter stating the reason for the return and that the transistors being returned are not defective. Also you may wish to state a preference for which devices you would like to receive as replacements, though we cannot always honor your request since we are limited to what we have in stock at the time. Due to the higher cost, TP9054 or 2SD555 devices cannot be sent as direct replacements.

*Output Drivers.* We have used only two types of output drivers in the past though three different types may be used (see below). The output driver is the *bottom* transistor in each of the output banks of the amplifier. **OUTPUT DRIVERS MUST NOT BE USED AS OUTPUT TRANSISTOR SUBSTITUTES AND VICE VERSA.** Output drivers *may* be mixed in the same channel without adversely affecting performance or reliability.

66546 (RCA) - this is our own number stamped on RCA 410 devices which may be available locally.

SJ2741 (Motorola) - found on early model 400's and 700 series amplifiers. May also be listed by Motorola as MJ2741 and should be available locally.

MJ1800 (Motorola) - standard Motorola number and should be available locally.

#### **SPECIAL NOTE**

We occasionally receive comments from field technicians that our output transistors read "leaky" on transistor testers and therefore cannot be used in a Phase Linear amplifier. Our engineering department has determined that due to the low gain/high current characteristics of these devices, standard transistor testers are *totally invalid* in checking for bad outputs in this application.

The only valid test we have found is an in-circuit operational test with the amplifier on and loaded. This test procedure can be found in any of the amplifier service manuals in the Troubleshooting Guide section under "Current Sharing Test" or "Operational Output Transistor Test".

SERVICE BULLETIN

1180

SUBJECT: Wave Form Oscillations in models 400, 700 and D-500 Series Two Power Amplifiers

On some model 400, 700 and D-500 Series Two amplifiers (or on some earlier units retrofitted with the Series Two PL36 drive PC boards) parasitic oscillations may occur causing excessively high distortion and/or thermal instability of the output stage. During sine wave bench testing these oscillations may show up on either or both the positive and negative half of the output sine wave.

The preferred solution to this problem is to install "slowdown" capacitors on the respective predriver transistor(s) from base to collector (see diagram). Predriver transistors are Q101, Q105, Q201 and Q205 for the 400 and 700 amplifiers, and Q101, Q107, Q201 and Q207 for the D-500 amplifier. 100-150pF should be adequate values in most instances, however, values up to about 250pF may be necessary to slow down the predrivers sufficiently. Capacitor values in excess of this may cause high frequency slewing and the unit should be troubleshot for other sources of the oscillations if a higher value is needed. Capacitors used for this modification should have at least a 100V rating.

PHASE LINEAR SERVICE DEPARTMENT  
20121 48th Ave. West  
Lynnwood, WA 98036  
(206) 774-8848  
(206) 774-3571

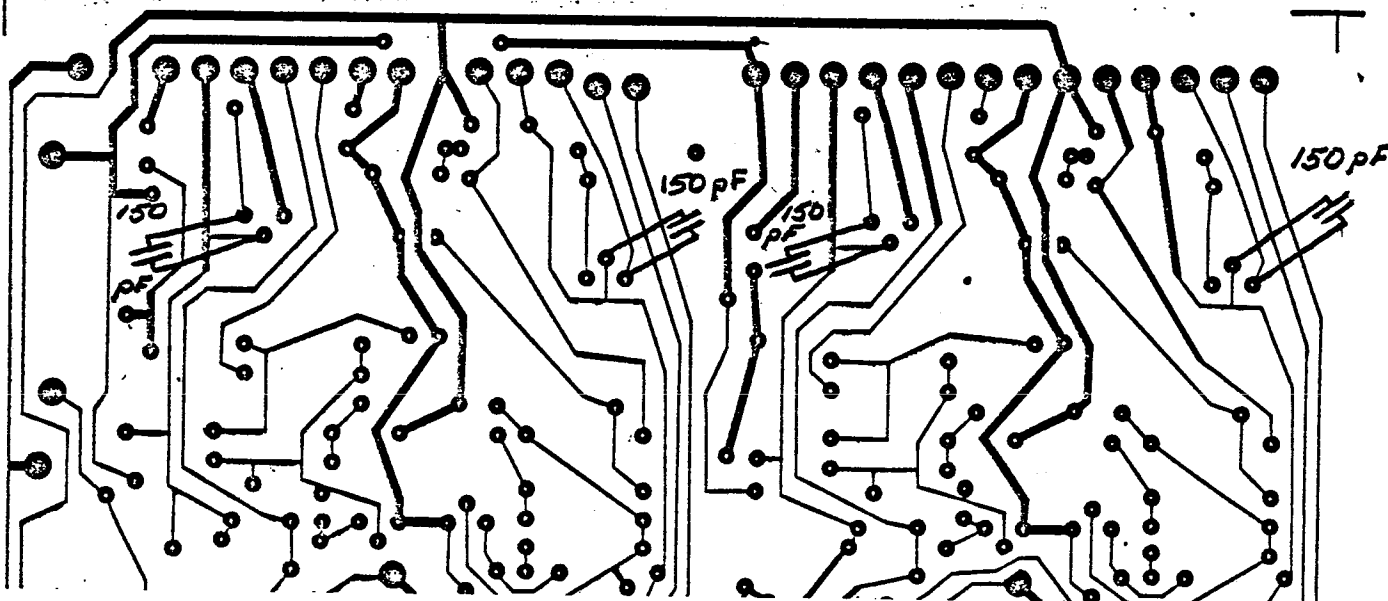

## SERVICE BULLETIN

Subject: D-500 Impedance Sensing Circuit Modification

We have found that on several early production runs of the model D-500 Series Two power amplifier a condition may exist where, when the amplifier is connected to a load impedance of greater than four ohms and driven by an input signal of sufficient amplitude in the "HI-Z" mode, the unit will prematurely switch into the "LO-Z" mode. This condition occurs only with upper mid-band and high frequencies and will always show up during bench testing of the amplifier.

To remedy this problem locate R505 (10K/¼-watt) in the Z-sensing circuit (see diagrams). To R505 add a 1.8K/¼-watt or ½-watt resistor in parallel for a resulting value of about 1.5K. This completes the modification. The existing schematic and assembly diagrams in the D-500 service manual show the revised (1.5K) resistor value.

When bench testing the amplifier after installing the modification verify that it will not prematurely switch from the "HI-Z" mode into the "LO-Z" mode when approaching the clipping level into a load impedance of greater than four ohms with a 20K Hz input signal.

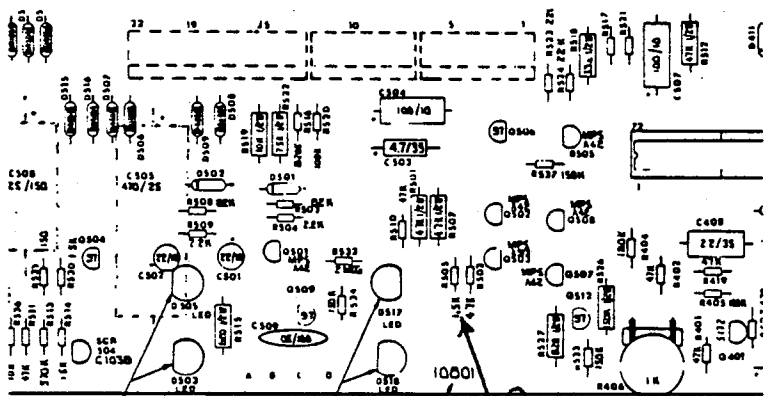

PL33 Display PCB

