

*Phase Linear 400*

**SERVICE MANUAL**

THIS DOCUMENT  
PROVIDED BY  
WATTS\_ABUNDANT.

CONTACT US AT

[watts.abundant@yahoo.com](mailto:watts.abundant@yahoo.com)

FOR PARTS AND  
SERVICE

MODEL 400  
POWER AMPLIFIER

Service Manual

Contents:

	p.
SPECIFICATIONS . . . . .	2
I. OPERATING INSTRUCTIONS . . . . .	3
II. CIRCUIT DESCRIPTIONS . . . . .	5
III. SCHEMATIC AND ASSEMBLY DIAGRAMS. . . . .	6-15
IV. DISASSEMBLY. . . . .	16
V. TEST PROCEDURE . . . . .	17
VI. TROUBLESHOOTING AND ALIGNMENT. . . . .	19
VII. SERVICE BULLETINS AND SUPPLEMENTS. . . . .	26
VIII. PARTS LIST - MODEL 400 . . . . .	back page

THIS MANUAL IS INTENDED FOR USE ONLY BY QUALIFIED PERSONNEL. HAZARDOUS VOLTAGES MAY BE ENCOUNTERED IN THE SERVICING OF THE MODEL 400 AMPLIFIER, AND ONLY QUALIFIED PERSONNEL WITH PROPERLY INSULATED AND PROTECTED EQUIPMENT SHOULD ATTEMPT SERVICE. USE EXTREME CAUTION AND READ ALL INSTRUCTIONS CAREFULLY.

Phase Linear Service Department  
20121 48th Ave. West  
Lynnwood, WA 98036

Tel. (206) 774-8848  
(206) 774-3571

prepared 6/76  
1st revision 6/80  
2nd revision 6/81

## TECHNICAL SPECIFICATIONS

POWER: 201 WATTS PER CHANNEL MINIMUM R.M.S. @ 8 OHMS  
FROM 20Hz to 20kHz.

TOTAL HARMONIC DISTORTION: less than 0.25%

TYPICAL THD: less than 0.1%

HUM & NOISE: minimum 100dB below rated output

DAMPING RATIO: 1000:1 @ 20Hz

RISE TIME: less than 1.7 microseconds

PHASE SHIFT: 0 degrees @ 20Hz; -12 degrees @ 20kHz

SENSITIVITY: PL400C PCB-1.7 volts for rated output  
PL14 PCB-1.2 volts for rated output

INPUT IMPEDANCE: PL400C - 47kOhms  
PL14A - 10kOhms  
PL14B - 39kOhms

SLEW RATE: 11 volts/microsecond

SPEAKER IMPEDANCE: will accept 4-ohm or greater speaker load

POWER CONSUMPTION AT IDLE: 40 watts

DIMENSIONS: 19w x 7h x 10d inches

SHIPPING WEIGHT: 35 lb.

provided that the speaker load driven is 8 ohms or greater in nominal impedance. Contact the factory for further details.

NEVER RACK-MOUNT THE AMPLIFIER WITHOUT PROVIDING ADDITIONAL SUPPORT FOR THE POWER TRANSFORMER.

And finally, a word about turn-off noise...

It is a characteristic of the model 400 power amplifier to display a delayed turn-off thump a few seconds after the unit is turned off. This is caused by the power supply discharging through the front end differential transistors. It should, however, be a fairly low level noise(it's not always a thump). If it is extremely loud and threatens loudspeaker damage refer to section VI-8.e. on page 25.

## II. CIRCUIT DESCRIPTIONS

### a. PC Drive Board PL400C:

Input signal is applied to the base of Q1. The output of the differential pair comprised of Q1 and Q2 is applied to the base of Q4. Q4 provides the final voltage gain to drive the pre-driver transistors Q7 and Q8. The PNP predriver Q7 serves as a phase inverter to drive the negative output driver transistor Q13. The emitter of Q13 drives the paralleled emitter follower output transistors Q14, Q15 and Q16. The positive half of the signal is amplified by emitter follower Q8 which in turn drives the paralleled outputs Q9, Q10 and Q12.

Forward bias is generated by bias regulator transistor Q3. R14 adjusts the slight amount of forward bias necessary to provide a few milliamps of idling current in the driver transistors which minimizes crossover distortion.

The protection circuit consists of Q5, Q6 and their associated R-C and diode networks. If the output current flowing through R25 and R36 becomes dangerously large, capacitors C12 and C13 acquire a voltage through R23 and R35 to cause Q5 and Q6 to turn on. Drive current is then shunted through D6 and Q5 around the predriver Q8, preventing an uncontrolled increase in output current. This prevents Q9 from driving the load. D12 and D13 are flyback diodes which prevent overvoltage from appearing across the output transistors in the event an inductive load is switched.

S1 is a thermal switch attached to the chassis between the heatsinks. It disconnects the line AC in the event the unit overheats.

b. PC Drive Board PL14(all):

Input signal is applied to the base of Q1. The output of the differential pair comprised of Q1 and Q2 is applied to the second differential pair Q3 and Q4. This second differential pair provides single-ended output which is applied to the base of Q5. Q5 provides the final voltage gain to drive the predriver transistors Q7 and Q10. The PNP predriver Q7 serves as a phase inverter to drive the negative output driver transistor Q12. The emitter of Q12 drives the paralleled emitter follower output transistors Q14, Q16 and Q18. The positive half of the signal from Q5 is amplified by emitter follower Q10, which in turn drives the paralleled outputs Q13, Q15 and Q17 through output driver Q11.

Diodes D6-D8 provide forward bias to the output bias regulator transistor Q6. R20 adjusts the slight amount of forward bias necessary to provide a few milliamps of idling current in the driver transistors which minimizes crossover distortion.

III. SCHEMATIC AND ASSEMBLY DIAGRAMS

	p.
Schematic Diagram, PL400C . . . . .	7
PCB Assembly Diagram, PL400C. . . . .	8
Schematic Diagram, PL14A. . . . .	9
PCB Assembly Diagram, PL14A . . . . .	10
Schematic Diagram, PL14B/02512. . . . .	11
PCB Assembly Diagram, PL14B/02512 . . . . .	12
PCB Assembly Diagram, PL18 Meter. . . . .	13
Wire Harness Diagram/Foil Pattern, PL400C . . . . .	14
Wire Harness Diagram/Foil Pattern, PL14B/02512. . . . .	15
Wire Harness Diagram/Foil Pattern, PL14A. . . . .	15

NOTE: All voltage measurements are made with no inputs or outputs connected to the amplifier.

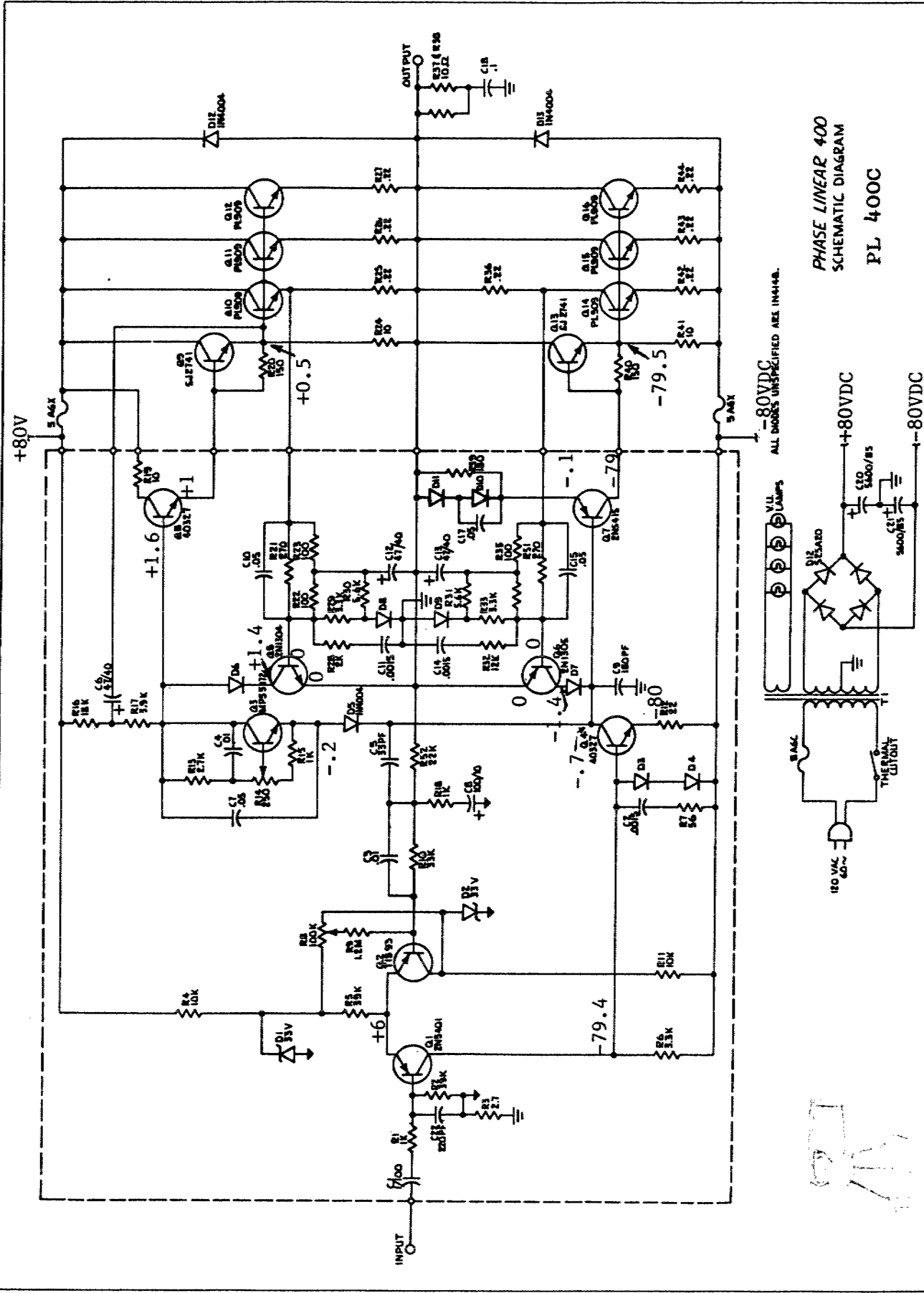

PHASE LINEAR 400  
SCHEMATIC DIAGRAM  
PL 400C

ALL DIODES UNSPECIFIED ARE 1N4448.



PHASE LINEAR 400  
 PCB ASSEMBLY  
 PL 400C

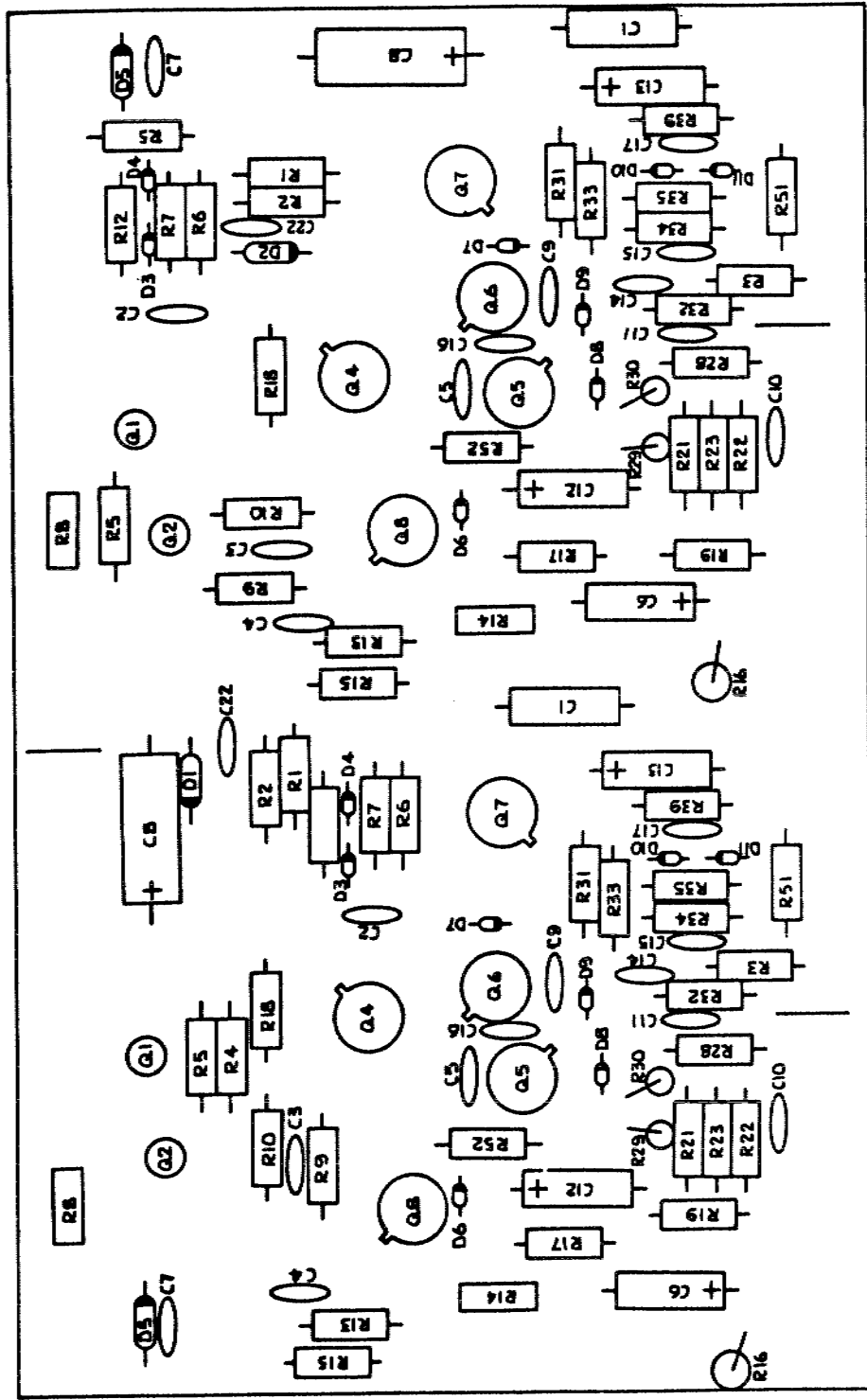

NOTE: Test measurements are made with no inputs or outputs connected to the amp.

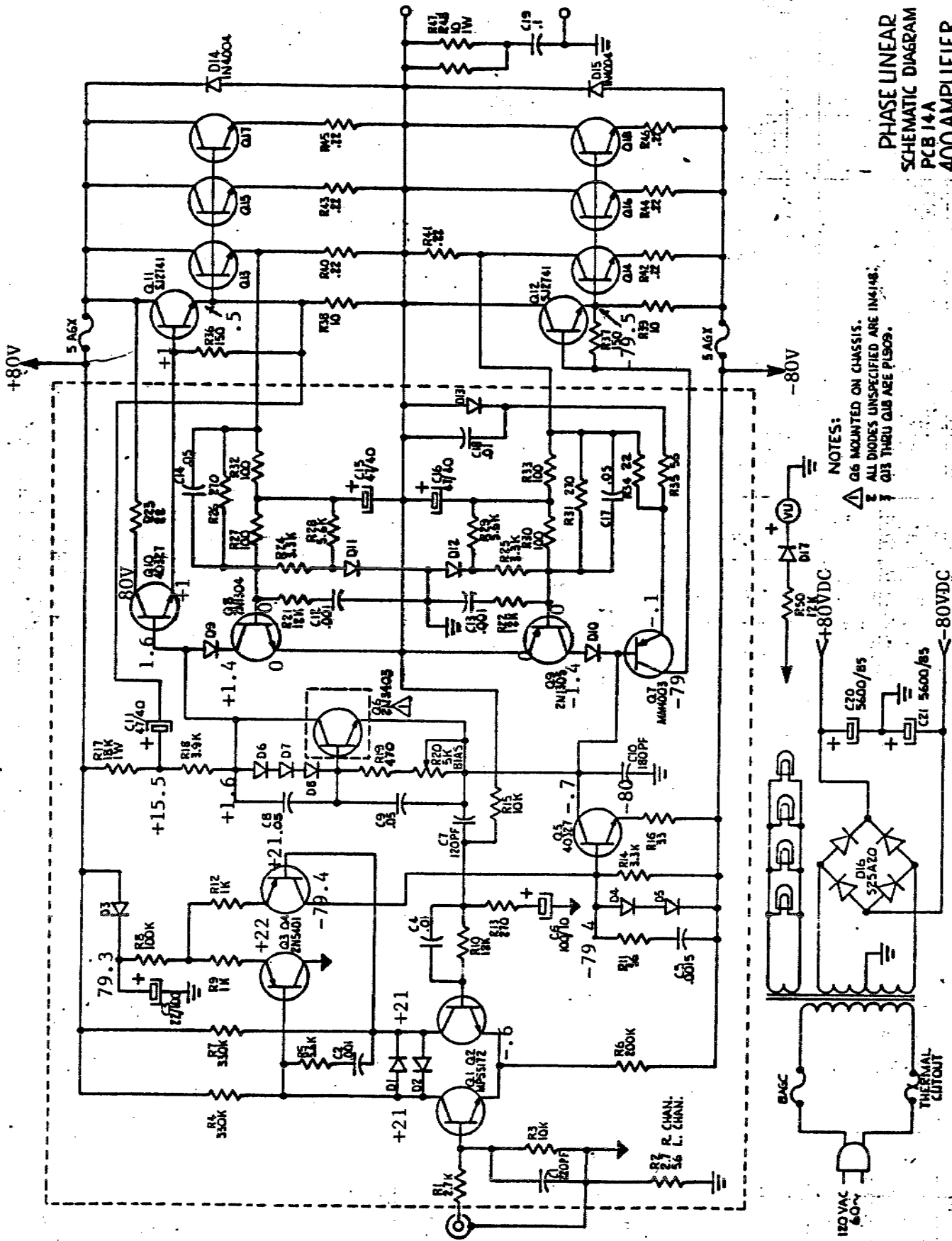

PHASE LINEAR  
SCHEMATIC DIAGRAM  
PCB 14A  
400 AMPLIFIER

Rev 9, 1973

- NOTES:
- △ G6 MOUNTED ON CHASSIS.
  - ⊗ ALL DIODES UNSPECIFIED ARE 1N4148.
  - ⊚ Q13 THRU Q18 ARE PL509.

PHASE LINEAR  
ASSEMBLY PCB14A  
400 AMPLIFIER

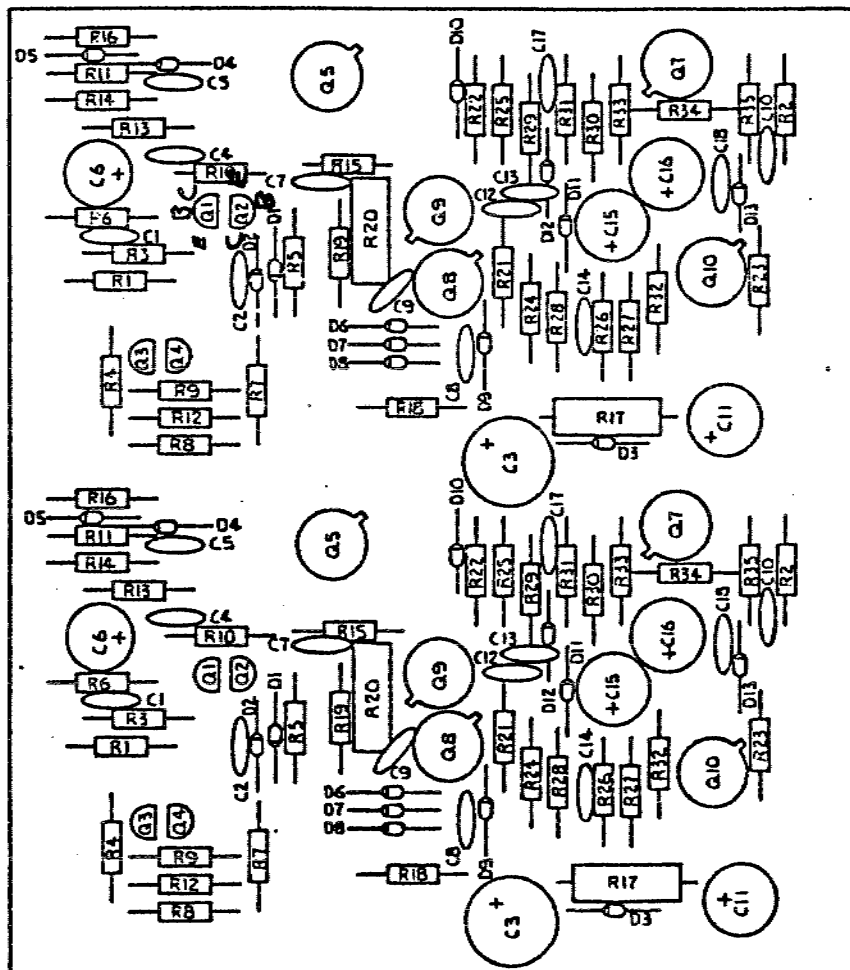
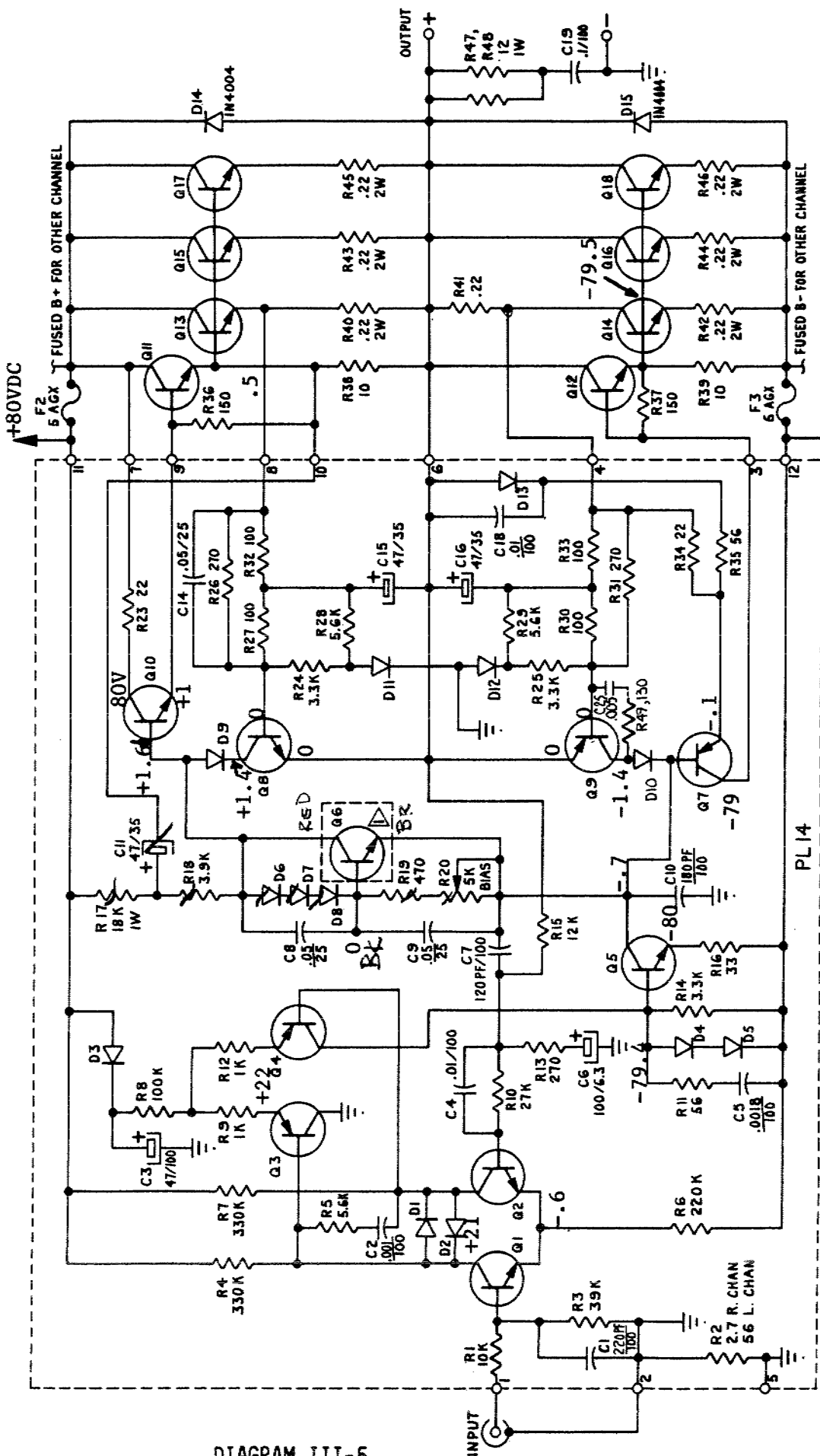

DIAGRAM III-5



NOTE: Test voltages are measured with no inputs or outputs connected to the amp.

PL 14

NOTES:  $\nabla$  Q6 MOUNTED ON CHASSIS.  
 2. ALL DIODES UNSPECIFIED ARE IN414B.  
 $\nabla$  EXPORT MODELS ARE 230VAC OR 250VAC.

TRANSISTORS
Q1, Q2 TIS-97
Q3 TIS-93
Q4 MPS-A93
Q5, Q10 4032T
Q6 2N3403
Q7 MM4003
Q8 2N1304
Q9 2N1305
Q11, Q12 6654C
Q13-Q18 PL 909

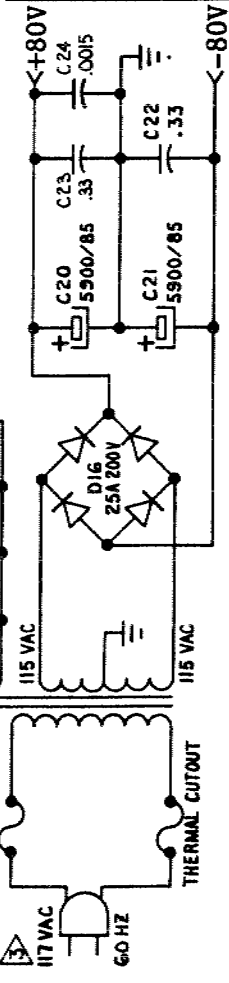

DRAWN	P. LANDRESSE 10/15/75
CHECKED	/ / /
APPROVED	/ / /
RELEASE STATUS	
PREL.	/ / /
FINAL	/ / /
DO NOT SCALE DWG.	SCALE NONE

Phase Linear	
SCHEMATIC	
400 AMPLIFIER	
SIZE	C
DWG. NO.	402471
REV.	N
PAGE 1 OF 1	

NOTE  
FOR SCHEMATIC SEE DWG 402471

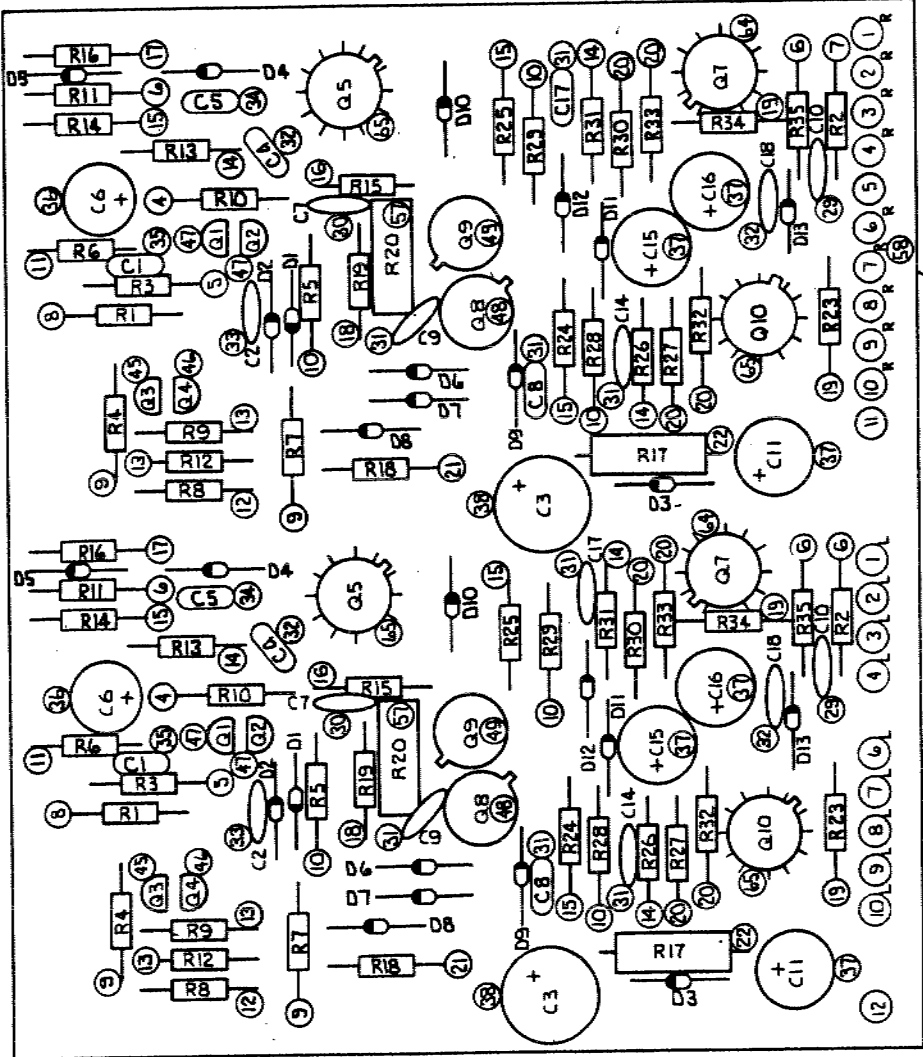

NOTES: UNLESS OTHERWISE SPECIFIED  
DIODES ARE IN4148.

O3 ASSY 400 POWER AMP PCB. PL14B.

- C- SAME AS D EXCEPT C1 IS 100PF/100
- D- SAME AS O1 EXCEPT EXTRA HOLES ARE ON PCB. AND ADD 1 JUMPER ON PAD 11.
- O1- SAME AS O2 EXCEPT Q1 & Q2 ARE MP5512Z.
- O2- SAME AS O3 EXCEPT R16 IS 200K & C5 IS .0015PF.
- O3- SHOWN

DRAWN	PICKENS	8-8-74
CHECKED		8-8-74
APVD		
RELEASE STATUS		
PREL		
FINAL		
DO NOT SCALE DWG		
C	PL14	402471
SCALE	2/1	
REV	H	
		SHEET 1 OF 1

PHASE LINEAR

PCB ASSY  
400 PWR AMP



DIAGRAM III-8. Wire harness diagram for PL400C.

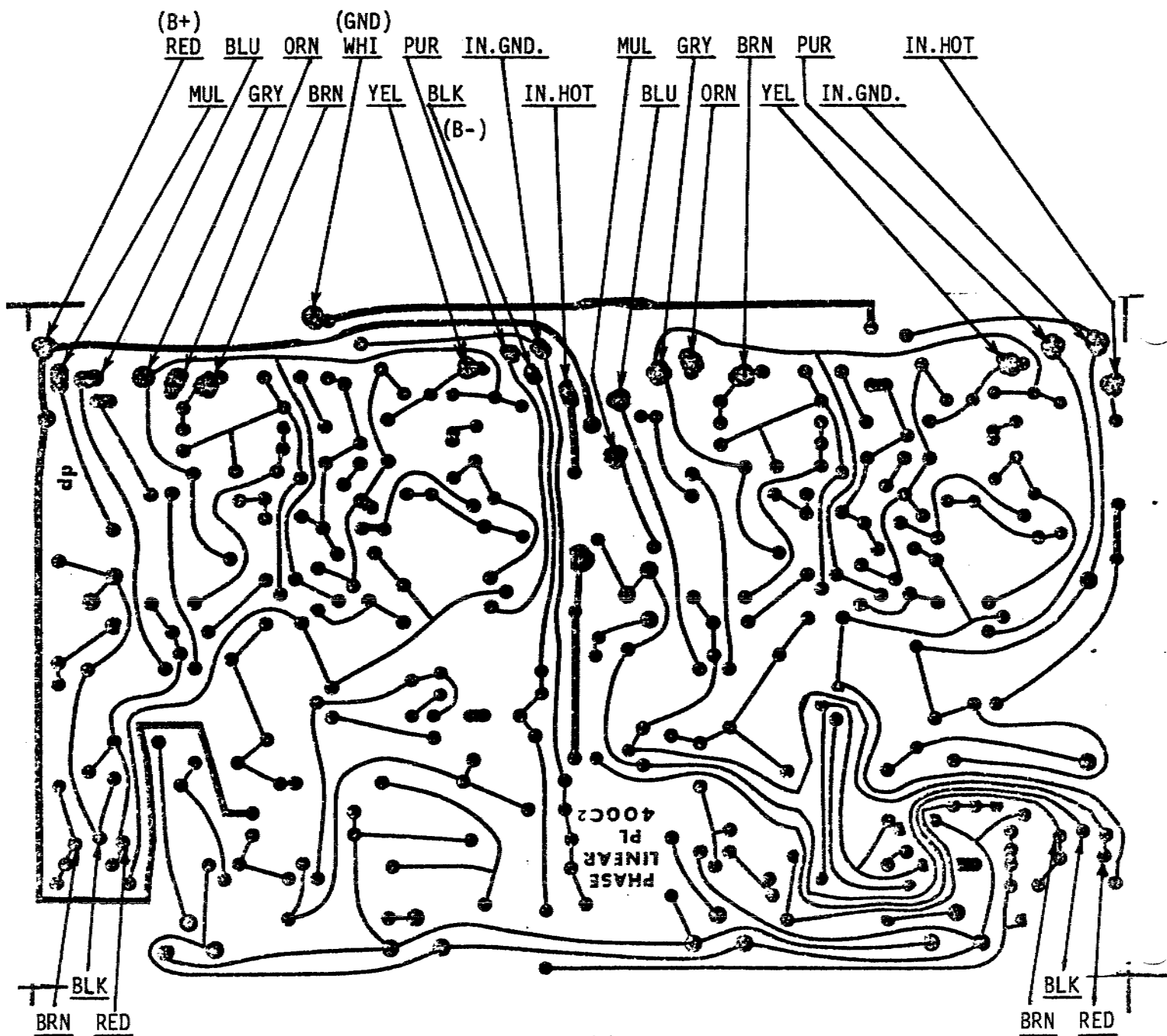
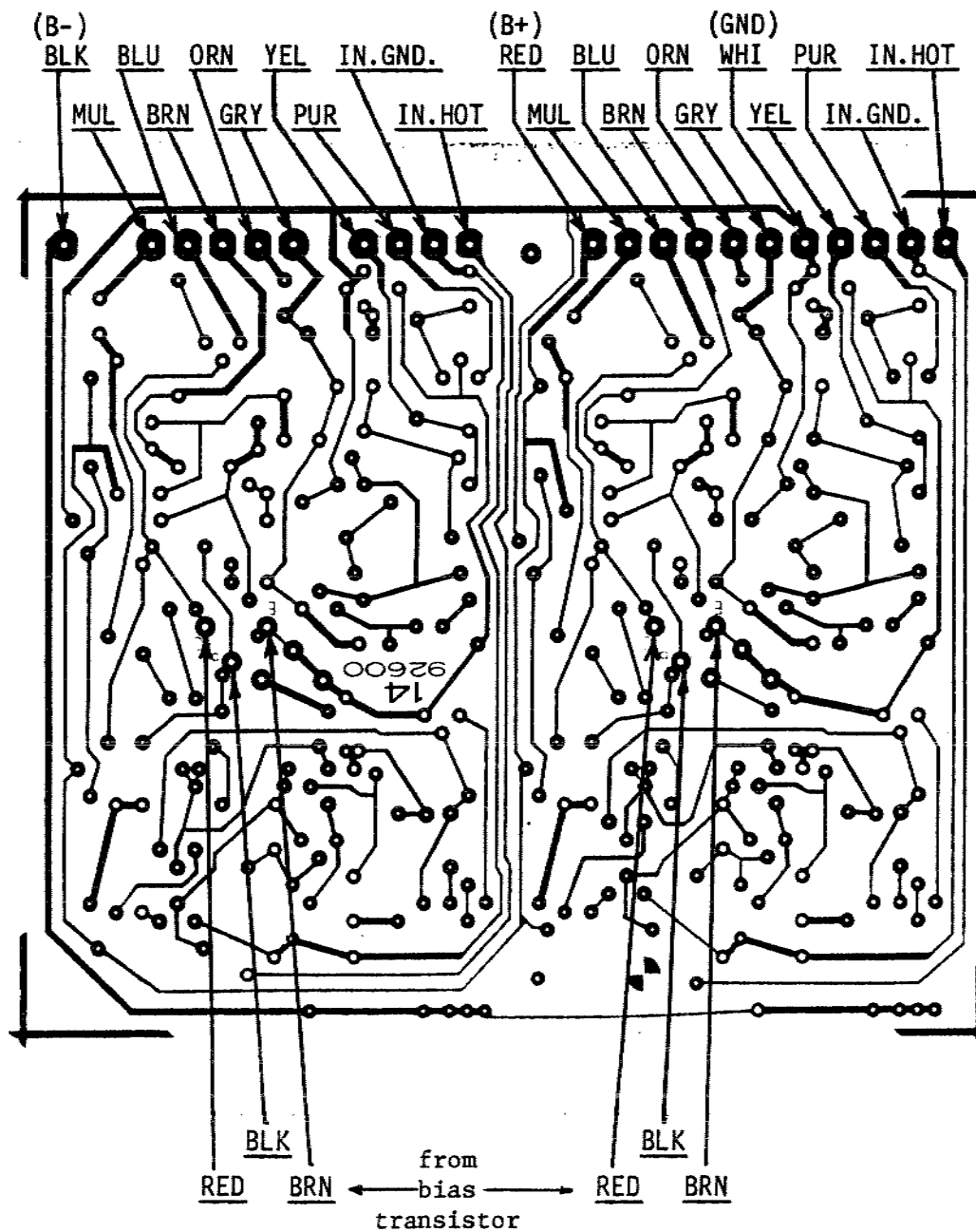

DIAGRAM III-9. Wire harness diagram for PL14 (a11)



#### IV. DISASSEMBLY

Step #1. Remove black top and bottom plates (10 phillips screws).

Step #2. Position the unit so that it rests on the heat sinks, with the front panel facing up. It will be necessary to place some type of support under the transformer so that the unit does not tip to the left (use a piece of foam rubber, small cardboard box, large banana or whatever is handy).

Step #3. Remove the 4 front panel nuts and bolts, taking care not to scratch either the front panel or the bolts. Lift the front panel off and set it down on edge to the rear of the unit. Avoid straining the wire harness and be sure that the meter lugs do not short against the chassis.

Step #4. Remove 3 hold-down nuts from the PL400C board, or 2 hold-down nuts from the PL14A and B boards, and flip the circuit board over and pull gently toward you. Before energizing the unit be sure that none of the PCB components are touching the rim of the chassis. The unit is now ready for test procedure.

Step #5. Re-assembly--reverse the above procedure (Note: to ensure that the unit will fit into a wood cabinet, align the front panel bolts so that the outer edge is parallel to the edge of the front panel).

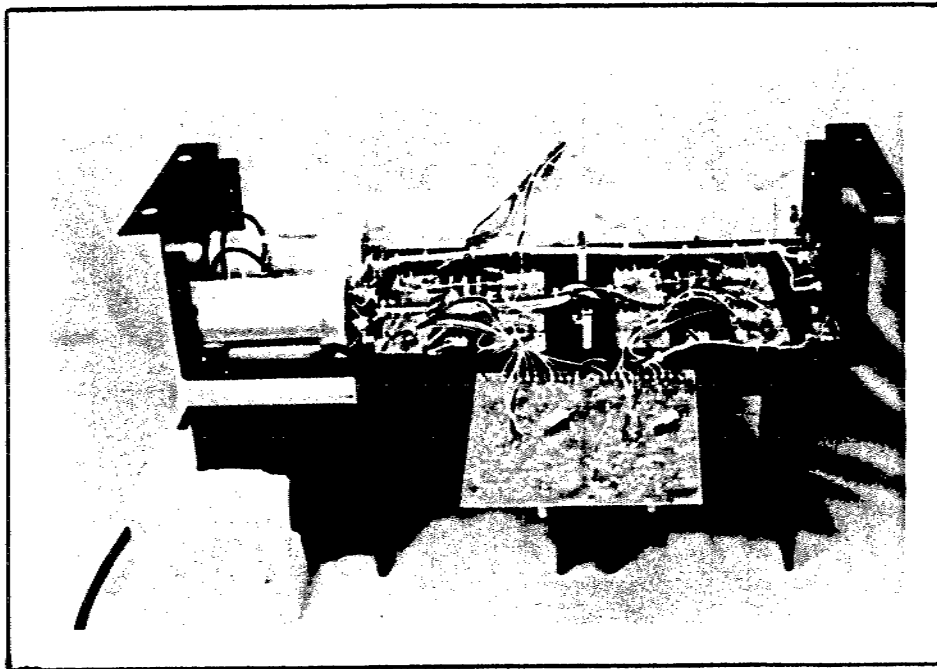

## V. TEST PROCEDURE

### Contents:

- V-1. Power supply
- V-2. Energizing the unit
- V-3. Output signal w/o load
- V-4. Output signal w/load
- V-5. Distortion
- V-6. Offset
- V-7. Short circuit test

### Required test equipment:

Audio signal generator  
High-impedance oscilloscope(dual-trace preferred)  
VOM or DVM  
8-ohm/250-watt resistive test load  
Variable line transformer(VARIAC)  
THD analyzer

V-1. Power supply. Before plugging in the AC line cord on the 400, check all fuses. Verify AGX-5 or AGX-8(fast-blow only) fuses for the power supply and AGC-8 or AGC-10(fast-blow only) for the line fuse. For 220-240VAC operation use only AGC-5 fuse in the line.

► CAUTION: If any fuse is discovered blown, do not energize the unit even after replacing the blown fuse(s). Follow the procedure in Section VI-1 to properly energize the unit without causing possible further damage to the output stage.

V-2. Energizing the unit. Plug the line cord into a variable line transformer and slowly turn it up to 117VAC(or 230VAC) as required. Verify immediate illumination of the front panel VU meters.

V-3. Output signal w/o load. Monitor the left channel output with the scope and AC voltmeter. DO NOT connect any other load to the outputs at this time. Drive the left channel input with a 2kHz sine wave until the output wave form is well into clipping. Verify that the clipping is symmetrical. Repeat for right channel.

V-4. Output signal w/load. Connect a 8-ohm/250-watt resistive load to the left channel output terminals and monitor the left channel output on the scope and voltmeter. Apply a 2kHz signal to the left channel input and verify at least 40V RMS output before clipping. Repeat the above at 20Hz, 200Hz and 20kHz for both left and right channels.

V-5. Distortion. Monitor the left channel output with a THD analyzer. With an 8-ohm load connected also to the left channel output, drive the left channel to 40V RMS and verify a THD of 0.25% or less. Repeat this procedure on the right channel.

This same procedure may be also used to test for IM distortion of 0.25% or less.

NOTE: It may be necessary to utilize the high filter in the distortion analyzer if it is so equipped.

V-6. Offset. Measure across the output terminals of each channel for presence of DC offset voltage. With no input or output connections on the amplifier verify  $\pm 50\text{mV}$  DC or less.

V-7. Short circuit test. With no signal driving the amplifier short the output terminals of the left channel with a jumper wire. Slowly turn up a 2kHz input signal and monitor the waveform on the scope. Verify that at output power level above one watt the waveform is truncated indicating shunt current to the output protection circuit transistors. Remove the jumper wire and verify that the amplifier resumes normal operation. Repeat for the right channel.

## VI. TROUBLESHOOTING AND ALIGNMENT

### Contents:

- VI-1. Power supply malfunction
- VI-2. Blown supply fuses/output transistor tests
- VI-3. Output malfunction with no load driven
- VI-4. Output malfunction with load driven
- VI-5. Excessive distortion/bias adjustment
- VI-6. Excessive offset voltage
- VI-7. Protection circuit malfunction
- VI-8. Miscellaneous malfunctions

NOTE: Most transistors and diodes in the 400 can be checked in circuit using an ohmmeter on the Rx1, Rx10 or 2K scale. With the 400 power OFF, measure the forward-biased resistance of the particular diode or transistor junction and verify a reading of 400 to 700 ohms on a typical DVM for a good device. Actual readings on good devices will vary from meter to meter, and some meters do not have sufficient test voltage to turn on a semiconductor. Nevertheless the shorted or open device is usually revealed quickly using this in-circuit method.

- CAUTION: BEFORE MAKING ANY MEASUREMENTS INTERNAL TO THE 400, UNLESS OTHERWISE SPECIFIED, BE SURE THAT THE LINE CORD IS INPLUGGED AND THE POWER SUPPLY CAPACITORS ARE FULLY DISCHARGED. WAIT AT LEAST TWO MINUTES AFTER UNPLUGGING THE AMPLIFIER TO ENSURE THAT THESE CAPS ARE DISCHARGED, OR DISCHARGE THEM BY SHORTING A 5-20 OHM (MINIMUM 5-WATT RATING) RESISTOR ACROSS THE CAPACITOR TERMINALS.

### VI-1. POWER SUPPLY MALFUNCTION

#### a. Blown line fuse.

1. Measure the bridge rectifier for shorted diode(s). This is most accurately done by disconnecting the positive and negative supply wires either at the filter capacitors or at the bridge. By disconnecting these wires, eliminated is the possibility of obtaining an inaccurate reading due to the DVM sample voltage on the R scale charging the supply caps.
2. Disconnect either positive or negative terminals from each filter capacitor (C20, C21) and measure each for possible internal short.
3. Disconnect power transformer secondary leads from the bridge rectifier and measure from primary to secondary for possible short. This has historically been a rarity.

b. Improper supply voltage. At idle the 400 positive and negative power supply voltages should each measure 80-84VDC, and measure within one volt of each other. If there is greater than 1 volt between supply measurements the defective filter capacitor is usually the lower reading of the two.

## VI-2. BLOWN SUPPLY FUSE(S)/OUTPUT TRANSISTOR TESTS

a. Blown supply fuse(s). If either of the supply fuses opens by a simple break in the filament replace the fuse(s) and re-test the amplifier. If the fuse displays any remote trace of a black or silver vaporized appearance on the glass wall DO NOT REPLACE THE FUSE(S) AND ENERGIZE THE UNIT AT THIS POINT since this may only cause further damage to the output stage.

First, perform the following test to check for defective output transistors:

▶▶ NOTE: IT IS NOT NECESSARY TO REMOVE EACH AND EVERY OUTPUT TRANSISTOR OR OUTPUT DRIVER TO LOCATE A SHORTED DEVICE.

Use a DVM or VOM set to the lowest resistance scale. Connect the negative lead to the collector bus wire of the suspected bank of output devices. Starting with the top transistor measure the resistance at its emitter with the positive lead. If the outputs in that bank are good you will get a reading just slightly lower than a typical semiconductor junction reading and you can go on to the next bank of outputs.

If that transistor, or any in that particular bank of transistors is shorted the meter will indicate a fraction of an ohm since the transistors are connected in parallel through their emitter resistors. Note the resistance reading and proceed from emitter to emitter (in that bank) testing in turn each device. When the shorted transistor is measured the meter will indicate slightly less (about .5 ohm) than it did on the good transistors.

If all transistor emitters in a bank have the same identical reading, suspect the output driver transistor as being shorted. Also, if an analog ohmmeter is being used care is required in reading the meter to spot the small differential in the shorted output emitter reading.

IMPORTANT: WHENEVER ANY OUTPUT TRANSISTOR HAS BEEN REPLACED IT IS NECESSARY TO PERFORM FOLLOWING STEP VI-2.b. TO VERIFY PROPER CURRENT SHARING OF ALL OUTPUT TRANSISTORS IN A BANK.

▶ WHEN REPLACING OUTPUT TRANSISTORS IT IS IMPORTANT THAT ONLY THE SAME MAKE AND DEVICE NUMBER BE INSTALLED IN ANY ONE CHANNEL. PLEASE REVIEW SERVICE BULLETIN 1-80 IN THE BACK OF THIS MANUAL.

b. Current sharing test. This test is necessary to verify that ALL output transistors are operating properly, ensuring a permanent repair (also see section VI-5 for bias adjustment). Although the amplifier will probably meet all specs without all outputs operational, increased current loading of the re-

maining outputs will result in a significant reduction in reliability and thermal stability.

1. With an 8-ohm test load connected to the output terminals of the left channel, drive the left input with a 200Hz signal to obtain a 40V RMS output. Turn down the line voltage on the VARIAC to about 75-80VAC. If a VARIAC is not available drive the inputs such that the amplifier is well into clipping.
2. Using a DC voltmeter measure the voltage drop across the output transistor emitter resistors in each output bank of the loaded channel. Verify that there is between 140 and 180 millivolts DC across each emitter resistor (this number may be higher if no VARIAC is being used to drop the line voltage).
3. Replace any output transistor whose emitter resistor voltage reading varies more than  $\pm 20\%$  from the typical. Also verify that the emitter resistor itself is not defective.

### VI-3. OUTPUT MALFUNCTION WITH NO LOAD DRIVEN

#### a. No output, one or both channels.

1. Check for blown supply or line fuse; refer to sections VI-1 and VI-2.
2. With line cord disconnected from AC outlet, check all PC board semiconductors (in circuit) as described under heading VI on page 19. Most output malfunctions which occur while driving an open load with the amplifier are the result of a defective component or assembly procedure on the PC drive board rather than in the output stage.

#### b. Excessive current drawn when voltage applied to the line cord.

1. Check the bias transistors (Q3 on PL400C; Q6 on PL14); replace if in doubt.
2. Check output transistors and output drivers per section VI-2.
3. Check all PCB semiconductors per section VI on page 19.
4. Isolate protection circuit as outlined in step c below.

#### c. Truncated or asymmetrical wave form output.

1. Verify matched power supply voltages at the filter capacitors per step VI-1.b. on page 20.
2. Protection circuit isolation: disconnect one end of diodes D9 and D10 (D6, D7 on PL400C PCB) and repeat the test. If the problem is now removed check/replace D9, D10, Q8, Q9, Q13 and Q14 (for PL400C PCB: D6, D7, Q5, Q6, Q10 and Q14).
3. Check predrivers Q7 and Q10 (Q7 and Q8 on PL400C), and check output drivers Q11 and Q12 (Q9 and Q13 on PL400C).
4. Possible defective Class A stage; check/replace Q5, D4 and D5 (Q4, D3 and D4 on PL400C).

d. Oscillations. (Also see section VI-7 PROTECTION CIRCUIT MALFUNCTION on page 24.)

1. Check RC output pole network R47/R48/C19 (R37/R38/C18 on units fitted with PL400C PCB). Replace if doubtful.
2. Replace predrivers Q7 and Q10 (Q7, Q8 on PL400C).
3. Replace output drivers Q11 and Q12 (Q9, Q13 on units fitted with PL400C PCB).
4. Check output transistor insulators. Occasionally the output transistor can pinch through the insulator as a result of thermal cycling, overtightening or previous replacement in which screw or socket metal particles become pinched between the insulator and heatsink. If this is found to be a trouble spot and the insulators used are the rubber (pink or gray) self-lubricating type it is recommended that these be replaced with the mica type with thermal transfer compound applied to them.
5. If oscillations (bursts) occur just before rated output at low test frequencies, be sure that line voltage at the line plug is maintained at 117-120VAC.

► NOTE: On some model 400 amplifiers several ferrite beads are positioned on the output stage busbar wiring. These are placed at the factory on a per-unit basis for maximum high frequency stability and it is recommended that they not be removed or altered in location.

On those 400 amplifiers which oscillate it may be necessary to place ferrite beads on the output bus wiring (usually on the output base bus wire). These are placed by experimental location.

VI-4. OUTPUT MALFUNCTION WITH LOAD DRIVEN

a. Unit will not deliver rated output (40VRMS) into 8-ohm load.

1. Check for line or VARIAC voltage sag. Voltage at the line plug must be at least 117VAC when delivering rated output of 40V RMS.
2. Possible defective (open) output transistor or output driver; see section VI-2 on page 20.

b. Asymmetrical or truncated wave form output.

1. Isolate protection circuit as outlined in section VI-3.c. on page 21.
2. Check for balanced power supply voltages at the filter capacitors (C20, C21) of + and - 80-84V with no more than 1 volt of variation between supplies.
3. Check for defective output transistor emitter resistors and/or open output transistors; see section VI-2.a. and b. on page 20.

## VI-5. EXCESSIVE DISTORTION/BIAS ADJUSTMENT

a. Bias adjustment. Check and adjust the pre-driver bias as follows:

1. Allow the unit to warm up sufficiently. Ideally the bias should be adjusted after the unit has achieved normal operating temperature.
2. Remove all input and output connections to the amplifier. Locate R38 and R39 (10-ohm,  $\frac{1}{2}$ -watt) in each output bank (R24 and R41 on units fitted with PL400C PCB).
3. Measure the DC voltage drop across R38 (R24 on PL400C units). Verify a reading of 300-400mV DC and adjust R20 in that channel on the PC board (R14 on PL400C) to obtain this reading. Once this measurement is obtained measure the DC voltage drop across R39 (R41 on PL400C units) and verify that it is within 20% of R38 (R24 on PL400C units).

▶ NOTE: For amplifiers used in sound reinforcement or commercial use it is recommended that the bias be adjusted closer to 300mV across R38 (R47 on PL400C units). This will increase distortion only slightly, but more importantly will provide for much cooler operating temperatures. A cooling fan is still recommended, however.

b. THD analyzer adjustments.

1. Activate the 80kHz filter on the analyzer if it is so equipped and repeat THD measurement.
2. Examine test bench grounding system for possible ground loops. Ground the analyzer directly to the 400 output ground and not to the load, scope or meter grounds. Use 16 gauge wire for the ground system.
3. Reverse the line cord polarity by removing the line plug from the AC outlet, reversing it and plugging it in again.

c. Defective protection circuit. Refer to section VI-7 PROTECTION CIRCUIT MALFUNCTION on page 24.

## VI-6. EXCESSIVE OFFSET VOLTAGE

For units fitted with PL400C PCB:

1. Remove all inputs to the amplifier. Monitor the DC offset voltage at the output of the left channel. Adjust offset voltage as close to 0V as possible via R8 on the PC board. Ideally offset should be adjusted after the amplifier has achieved normal operating temperatures.  
Repeat the above step for the right channel. Offset should be less than 50mV after final adjustment.
2. If DC offset cannot be zeroed (less than 50mV) replace differential transistors Q1 and/or Q2 and readjust per step 1 above.

For units fitted with PL14 PCB:

1. Remove all inputs to the amplifier. Monitor the DC offset voltage at the output terminals of the left channel. Ideally offset should be adjusted after the amplifier has achieved normal operating temperature. Offset should measure less than 50mV. Repeat measurement for the right channel.
2. The DC offset in the PL14 PC boards is determined by matching of the first differential pairs in each channel (Q1,Q2). If DC offset measures more than 50mV in either channel replace Q1 and/or Q2 in that channel. Occasionally Q3 and/or Q4 will affect offset as well.

VI-7. PROTECTION CIRCUIT MALFUNCTION

Supply fuse(s) open when amplifier output terminals are shorted.

This indicates that the protection circuit is not shunting drive current properly.

1. Check/replace Q8,Q9 and D9-D12(Q5,Q6,D8-D11 on PL400C).
2. Check/replace R40-R42,Q13 and Q14(R25,R36,R42,Q10 and Q14 on units with PL400C PCB).
3. Perform step V-7 on page 18 after defective devices have been replaced to verify proper protection circuit operation.

VI-8. MISCELLANEOUS MALFUNCTIONS

a. Meter(s) peg when unit is turned on. Occasionally when a model 400 is turned on there may be a condition where there is sufficient leakage in one or more output transistors, or the output transistor(s) may short in such a way that the supply fuse(s) will not blow, passing the 80V supply voltage to the loudspeakers. The display meter for the defective channel will usually peg to full output deflection. This symptom should be troubleshot as if a shorted output transistor condition existed, and see also section VI-3. OUTPUT MALFUNCTION WITH NO LOAD DRIVEN on page 21.

This condition also reinforces the need for external speaker fusing as described on page 3, section I-4.

b. Hum. If hum is heard through loudspeakers in a home system be sure that the preamplifier is not stacked directly above or beneath the power amplifier. The model 400 power transformer radiates a very large hum field which can be picked up by poor or non-shielded high gain circuitry.

Also, fluorescent lighting in the vicinity of the power amp can inject hum into the power supply as can AC line rheostats ("dimmer switches"). There is little that can be done for these two conditions.

1. Remove the line plug from the AC outlet and reverse the polarity by turning the plug over and plugging it back into the AC outlet.

2. Tighten the 7/16" power transformer bolts since a loose transformer lamination can vibrate at line frequency and be transmitted into the signal.
3. Tighten the terminals at the power supply filter capacitors.
4. Tighten the ½" nuts which attach the input jacks to the chassis. This can be done externally with no other dis-assembly required.

c. Radio Frequency Interference (RFI). Most from a model 400 is radiated by the bridge rectifier in the power supply.

Connect four .01/1000v ceramic or mylar capacitors across each terminal of the bridge rectifier as shown:

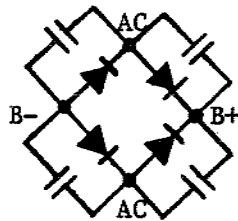

d. Low output at low frequencies. This is usually caused by a defective capacitor or resistor in the negative feedback loop. Replace C6 (100/10v lytic), R13, R10 and/or C4. C6 is the most common culprit.

e. Turn on/off noise. A delayed turn-off noise (usually a thump) is characteristic of the model 400 power amp. This is caused by the power supply voltage discharging through the front end differential transistors, and should be a fairly low level noise. If the noise is extremely loud and poses a threat to the loudspeakers connected to the amp the following measures, applicable only to units fitted with the PL14 series drive PC board, should be observed:

1. Replace D3 in the defective channel and check C3.
2. Check/replace Q1 and/or Q2.
3. Check/replace Q3 and/or Q4.

Model 400's fitted with the PL400C drive PC board have very little which can be done about turn-off noise aside from experimental matching of the front end differential transistors.

An alternative to any of the above procedures for all 400's is the installation of an output relay which insures elimination of any turn-on/off noises. The associated PC board which accompanies the relay also provides DC and subsonic frequency protection. Contact the factory service department for details and availability.



*Phase Linear*

20121 - 48th Avenue West, LYNNWOOD, WASHINGTON 98036 U.S.A. Telephone: (206) 774-3571

**SERVICE BULLETIN** 1-80

**IMPORTANT!! ALL PHASE LINEAR PRODUCT SERVICING PERSONNEL PLEASE READ...**

**SUBJECT:** Models 400 Series, 700 Series, and D-500 amplifier output transistors and output driver transistors.

Since Phase Linear amplifiers began production several years ago we have incorporated several different types of output transistors and a few variations on output driver transistors. *Only* those which we have used in the past have been tested and approved by our engineering department for use in Phase Linear amplifiers. It is very important that **ALL OUTPUT TRANSISTORS USED IN PHASE LINEAR AMPLIFIERS BE THE SAME IN EACH CHANNEL**, that is, they must match by make and device number. Mixing output transistors in the same channel will adversely affect performance, reliability, and/or thermal stability. Therefore when replacing defective output transistors be sure to use only the same make and number used in that particular channel.

The following is a list of output transistors used in the past and their disposition. *Only* these devices have been approved for use in any of the 400 or 700 series amplifiers. Do not attempt to cross-reference these devices to another type of output transistor (2N, Sylvania ECG, etc.) since in the past the use of these devices has resulted in various kinds of amplifier malfunctions or direct failures. Also notice that the model Series Two D-500 uses *only one type* of output transistor (TP9054).

TP9054 (Motorola) - used in some production runs of Series Two model 400II and 700II. This is a higher voltage (and subsequently more expensive) device than the other output transistors. The model D-500 uses TP9054's *exclusively*; no other output transistor should be used in this amplifier. TP9054 is our own number stamped on Motorola MJ15024 devices. If MJ15024's are available locally they may be mixed with TP9054's in the same channel; this is one of *only two* exceptions to the mixed output rule (see XPL909).

XPL909 (Delco) - used in original 400's and 700's to the present. Some early XPL909's were marked PL909 and should not be confused with the Fairchild PL909 transistor. Delco PL909's are marked with *blue* ink and should be considered as XPL909 when ordering replacements. XPL909 is our own number stamped on selected Delco DTS411 devices. If DTS411's are available locally they may be mixed with XPL909's in the same channel. This is one of *only two* exceptions to the mixed output rule (see TP9054). XPL909's are no longer used or stocked as replacement parts.

F

PL909 or FPL909 (Fairchild) - notice the 'F' above PL909. This is how the number appears on the device. Do not confuse Fairchild PL909's with early Delco PL909's. All Fairchild PL909's are marked with *black* ink and should be considered as FPL909 when ordering replacements.

XPL910 (Delco) - these are power Darlington devices and are no longer used in production. Be sure not to confuse or mix these with XPL909's since the design markings on both devices are identical.

1B05 (RCA) - this is RCA's number and these should be available locally. They are no longer used in production.

MJ15011 (Motorola) - this is Motorola's number and these should be available locally. They are no longer used in production.

SE230 (Sensitron) - may be found only on very early model 400's. This is Sensitron's number and these may be available locally.

(cont.)

PL909A (Motorola) - notice the 'A' suffix. These may be found only on very early model 400's and possibly an early 700. These were found to have inconsistent reliability traits and should *all* be replaced in the amplifier whether good or defective. See exchange policy below.

2SD555 (NEC) - was never used in production runs of 400 or 700 series but is a suitable replacement transistor and is slightly more expensive than other outputs. These should be available locally.

*Exchange Policy.* Since some of the approved output devices have been dropped from our production runs and others are no longer stocked it may be necessary to replace all of the output transistors in one channel of an amplifier if duplicate replacements are not available.

We will be glad to exchange good (non-defective) output transistors for what we have currently available in stock at no charge *providing that* there be included with the transistors returned a note or letter stating the reason for the return and that the transistors being returned are not defective. Also you may wish to state a preference for which devices you would like to receive as replacements, though we cannot always honor your request since we are limited to what we have in stock at the time. Due to the higher cost, TP9054 or 2SD555 devices cannot be sent as direct replacements.

*Output Drivers.* We have used only two types of output drivers in the past though three different types may be used (see below). The output driver is the *bottom* transistor in each of the output banks of the amplifier. **OUTPUT DRIVERS MUST NOT BE USED AS OUTPUT TRANSISTOR SUBSTITUTES AND VICE VERSA.** Output drivers *may* be mixed in the same channel without adversely affecting performance or reliability.

66546 (RCA) - this is our own number stamped on RCA 410 devices which may be available locally.

SJ2741 (Motorola) - found on early model 400's and 700 series amplifiers. May also be listed by Motorola as MJ2741 and should be available locally.

MJ1800 (Motorola) - standard Motorola number and should be available locally.

#### **SPECIAL NOTE**

We occasionally receive comments from field technicians that our output transistors read "leaky" on transistor testers and therefore cannot be used in a Phase Linear amplifier. Our engineering department has determined that due to the low gain/high current characteristics of these devices, standard transistor testers are *totally invalid* in checking for bad outputs in this application.

The only valid test we have found is an in-circuit operational test with the amplifier on and loaded. This test procedure can be found in any of the amplifier service manuals in the Troubleshooting Guide section under "Current Sharing Test" or "Operational Output Transistor Test".

# Phase Linear Corporation

20121-48 Avenue West  
Lynnwood, Washington 98036 USA  
206 774-3571 TWX 9104492851

SERVICE BULLETIN

6-76  
rev 6-81

Subject: TO-92/TO-18 Transistor Pin Patterns

All Phase Linear products incorporate one or more type of the small plastic case TO-92 or TO-18 packaged transistors. Unfortunately these do not all have the same pin configuration and since different pin pattern transistors are interchangeable we feel that a few diagrams are in order.

These types of transistors fall into two basic categories: in-line or TO-92 as shown in diagram 1, and triangular(offset) or TO-18 as shown in diagram 2. These pin configurations apply to the transistors listed below each diagram, but not necessarily to any transistor made in that package. BE SURE TO CHECK THE PIN PATTERN WHENEVER REPLACING A TRANSISTOR WITH ONE OF A DIFFERENT NUMBER OR PACKAGE. The most commonly confused are the MPS5172 replaced with GES97 or TIS 97, and GES93 or TIS 93 replaced with a MPS A93. To further complicate matters, a few years ago GE changed the pin pattern on the GES97 and GES93 transistors, two of our most commonly used. Therefore both of these devices were used in both in-line and triangular packages. It is important that these be examined for proper installation if being used as a replacement part.

NOTE: For example, if you've just replaced Q1 and/or Q2 in a PL14 PCB and the amp seems to work okay except for ten or fifteen volts of offset, you've stuffed them in backward.

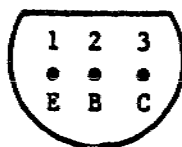

Bottom View

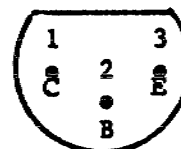

Diagram 1  
TO-92

MPS A93  
MPS A55  
GES97(later versions)  
GES93(later versions)  
MPS5172  
MPS A18  
2N5401(obsolete)  
3569  
4355  
8599

Diagram 2  
TO-18

TIS97  
GES97(earlier versions)  
TIS93  
GES93(earlier versions)  
KA1778\*

(\*in-line version of KA1778 but has triangular pin pattern, i.e., pins 1-2-3 are C-B-E, respectively.



# *Phase Linear Corporation*

20121-48 Avenue West  
Lynnwood, Washington 98036 USA  
206 774-3571 TWX 9104492851

## SERVICE BULLETIN

1-76  
rev 6-81

SUBJECT: Replacement of Transistor 2N5401

Our statistics and quality control have revealed that in later use of Motorola transistor 2N5401, excessive breakdown occurred with the PL14 series of model 400 and 700B drive PC boards. Therefore, any 2N5401 transistor which has failed should be replaced with Motorola transistor MPS A93 (Phase Linear part no. 126-0028).

In all models of 700B and 400 which contain any of the PL14 series of drive PC boards it is advisable to replace Q3 and Q4 in both channels even though the channel(s) may be operable. If MPS A93 is already used for Q3 and/or Q4, replacement is not necessary unless the device is defective. Q3 alternately used MPS A93 or TIS93 depending on the production run and either is permissible. Q4 should only be replaced with MPS A93 and nothing else.

Q1 and Q2 will accept either TIS97, GES97 or 2N5172 as suitable parts, although both will want to be the same number since the matching of these two differential transistors will determine offset voltage at the output of the amplifier (see OFFSET VOLTAGE under the TROUBLESHOOTING AND ALIGNMENT section of the service manual).

Model 400 Service Manual SUPPLEMENT

Subject: Changing Line Voltage Setting and Fusing

All model 400 amplifiers were factory fitted with power transformers capable of operating on only one given AC line voltage. Only a scattered few model 400's were fitted with dual-primary (117/220v) power transformers, mostly those with serial numbers above 15000.

For most model 400 amplifiers the only means of changing line voltage operation is with the use of a step-up or step-down external transformer, or by changing the power transformer on the amplifier. Dual-primary power transformers are available from the factory as part number 125-0033. Contact the factory service department for current prices and availability.

Once a model 400 is equipped with the dual-primary transformer, or for those few units which are presently equipped with one, the following is a diagram which explains the proper wiring for either 117/120VAC or 220/240VAC operation:

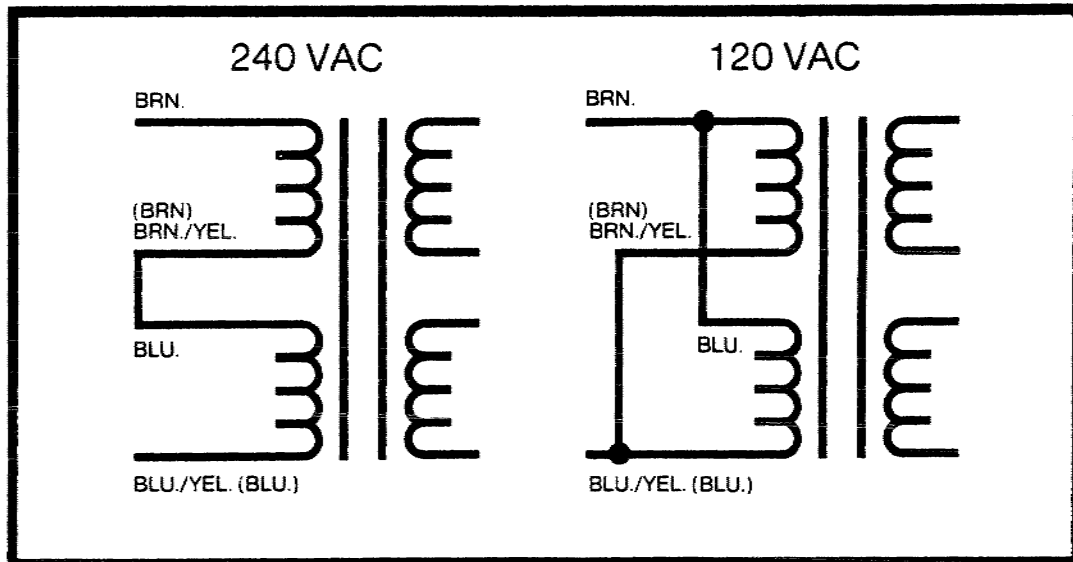

IF THE PRIMARY VOLTAGE IS CHANGED, THE LINE FUSE MUST BE CHANGED AS FOLLOWS:

120 VAC: Use 10 AMP, Type AGC

240 VAC: Use 5 AMP, Type AGC



# Phase Linear Corporation

20121-48 Avenue West  
Lynnwood, Washington 98036 USA  
206 774-3571 TWX 9104492851

2/80  
rev 6/81

## SERVICE BULLETIN

SUBJECT: Infinity Speakers with Watkins(TM) Woofer System

Due to the crossover design of the Watkins(TM) Woofer system, a very large capacitance value (1000-2000 uF) is seen by the amplifier. Normally this capacitance is not a problem, however under some operating conditions trouble can occur. Avoid turning off the amplifier and turning it back on before the crossover completely discharges (usually 1-2 min.). The amplifier charges the capacitors at turn-off, and upon turn-on they discharge back into the amplifier, causing offset and/or damage to the amplifier and/or speaker. To bleed off this charge a resistor shunt at the speaker terminals for the woofer is recommended (see diagram below). The value for the resistor is 150 ohm/10 watt.

For further information contact: Infinity Systems, INC.  
(213) 883-4800  
Canoga Park, California

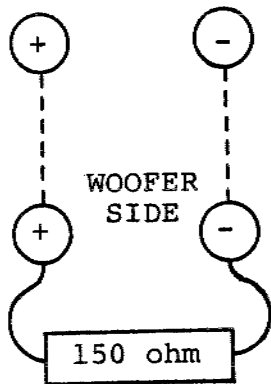

(10 watt)

--- BI-AMP LINK

Model 400 Service Manual SUPPLEMENT

Subject: Retrofitting of Series Two Drive PC Boards(PL36)  
to Pre-Series Two Output Stages

Both the PL400C and PL14 series of PC drive boards used in the model 400 are no longer available from the factory as new replacements, although rebuilt units can be purchased. Contact the factory service department for current prices and availability.

It is possible to retrofit the newer Series Two drive PC board (PL36) into an older model 400 if a new circuit board must be installed. The main difference between the PL14 and PL36 drive PC boards is the replacement of the discrete front end differential transistors with a modern FET input op amp(LF351 or LF356). The new design offers lower noise, greater stability, lower offset, higher common mode and power supply rejection, higher open loop gain, and faster speed, thus allowing a reduction of output bias current.

These new circuit boards also have silicon protection circuit transistors(to replace the previously used expensive germanium types)which require prebiasing in order to perform properly when retrofitted to early 400 output stages. The prebiasing comes from resistors connected between the positive and negative supplies to the bases of the protection circuit transistors(see fig.1). The four resistors should be valued at 39k ohms( $\frac{1}{2}$ -watt)for early 400's.

The wiring harness connections for the newer PL36 circuit boards are the same as for earlier 700B(PL20)circuit boards. See fig.2.

Occasionally PL36 boards retrofitted into earlier 400 output stages may develop parasitic oscillations causing excessively high distortion and/or thermal instability. During sine wave bench testing the oscillations may show up as riding on either half of the wave form.

The preferred solution to this is the installation of "slowdown" capacitors attached from base-to-collector on each of the predriver transistors, Q101/Q201(40327)and Q105/Q205(MM4003)as per the diagram below. Suitable capacitors are ceramic or mylar, 100-150pF with minimum 100v rating. Capacitors up to around 250pF may be used if necessary, although values higher than this may cause high frequency slewing and the unit should be troubleshot for other oscillation source areas.

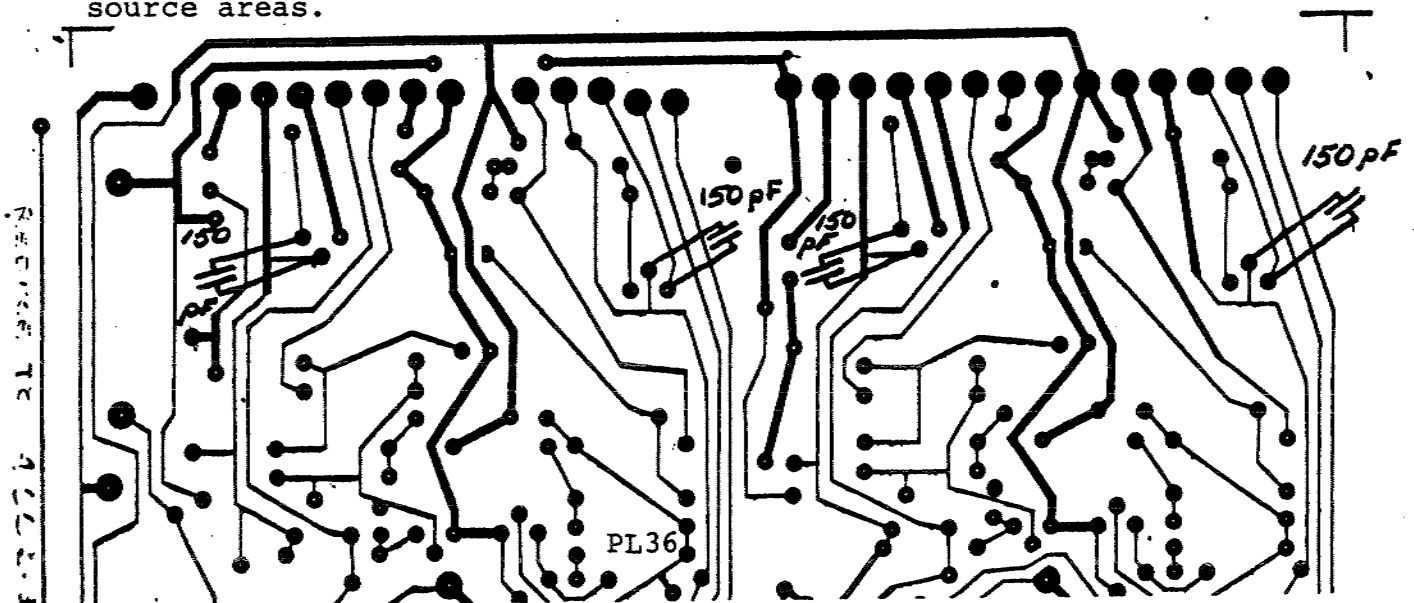



VIII. PARTS LIST - Model 400

TRANSISTORS: PL Part No.  
 XPL909, FPL909, MJ15011,  
 1B05, 2SD555.....126-0015  
 RCA410, 66546, MJ2741.....126-0016  
 40327.....126-0007  
 MM4003, 2N5415.....126-0006  
 2N3403.....126-0018  
 2N1304.....126-0004  
 2N1305.....126-0013  
 MPS A93.....126-0028  
 MPS 5172.....126-0010  
 TIS93, GES93.....126-0009  
 TIS97, GES97.....126-0033

DIODES:  
 Bridge rect:S25A20.....126-0001  
 1N4148.....126-0002  
 1N4004.....126-0003  
 1N4752(33v).....126-0017

CAPACITORS:<sup>1</sup>  
 5900/85v:lytic.....127-0021  
 47/35v:lytic:rad.....127-0032  
 47/100v:lytic:rad.....127-0065  
 100/6.3v:lytic:rad.....127-0033  
 .01/100v:mylar.....127-0063  
 .33/100v:mylar.....127-0027  
 .22/400v:mylar.....127-0041  
 .01/100v:disc.....127-0005  
 .05/25v:disc.....127-0007  
 .001/100v:disc.....127-0062  
 .0018/100v:disc.....127-0039  
 220pF/100v:disc.....127-0042  
 180pF/100v:disc.....127-0009

RESISTORS:  
 .22/2watt.....128-0354  
 5/5watt.....128-0357  
 18k/2watt.....128-0347

SWITCHES:  
 Thermal cut-out.....129-0030

TRANSFORMER:  
 117/115v sec:CT.....125-0002  
 117-220/115 sec:CT.....125-0033

PRINTED CIRCUIT BOARDS:Part No.<sup>2</sup>  
 PL14 Drive:rebuilt.....210-0003  
 PL400C Drive:rebuilt... - -  
 PL18 Meter/Lamp PCB....210-0006  
 PL36 Drive(Series II)..210-0156

METERS/FRONT PANEL COMPONENTS:<sup>3</sup>  
 Meter Assembly.....123-0001  
 Meter Movement(Jewell).130-0067  
 Meter Lens(Cover).....142-0066  
 Lamp:#1784.....121-0046  
 Lamp:FL6/6(fuse type).. - -  
 Meter Bezel:black.....142-0005  
 Meter Bezel Clip.....210-0064

METALWORK:  
 Front Panel.....220-0002  
 Chassis.....141-0004  
 Cover:top:bottom.....141-0007  
 Heatsink:lg:outside....141-0005  
 Heatsink:sm:inside....141-0025  
 Cover:trnstr:2-bank...210-0006  
 Cover:trnstr:1-bank...141-0030  
 X-fmr end bell:outer...142-0015  
 X-fmr end bell:inner...142-0003  
 Clamp:pwr supply cap...141-0140

HARDWARE:  
 Nut:hex:¼-20.....122-0015  
 Screw:top,btm.cover...122-0001  
 Bezel clip:meter.....210-0064  
 Nut:hex:kep:6-32.....122-0018

MISCELLANEOUS:  
 Jack:phono:input.....121-0002  
 Binding post:white....121-0006  
 Binding post:red.....121-0007  
 Binding post:black....121-0008  
 Line cord:l8-2.....121-0016  
 Strain relief:line cord121-0029  
 Fuseholder:AGX(supply).121-0011  
 Fuseholder:AGC(line)...121-0010  
 Fuse:AGX-5.....121-0037  
 Fuse:AGX-8.....121-0038  
 Fuse:AGC-10.....121-0039

<sup>1</sup>All values in microfarads unless otherwise stated.

<sup>2</sup>New PL14 or PL400C drive circuit boards are no longer available, however, rebuilt editions may be. Contact factory service department for current prices and availability. If new drive PCB must be installed PL36(re 400 Series Two) may be retrofitted. See service manual SUPPLEMENT, "Retrofitting of Series Two Drive PC Boards(PL36) to Pre-Series Two Output Stages" in the back of the service manual.

<sup>3</sup>When ordering meters or meter replacement parts BE SURE to specify the manufacturer of the meter assembly as cast on the meter housing. Meter movements are only available as made by JEWELL, otherwise complete meter assembly must be ordered.