

Nottingham

Analogue Studios

Dealer Manual

Table of Contents

1. Essential tools
2. Set up Specs
Distance from Tone arm center to spindle
Effective Mass of Tonearms
Nottingham Cartridge specs
3. Set up tips
The meaning of tight
Thoughts on VTA
Thoughts on Bias (anti-skate)
Motor height
Getting the tone arm position right
Installing and positioning the cartridge
Getting the right amount of oil in the bearing
Positioning your table – (including leveling, mains connection)
What about the plinth?
4. Maintenance & Service
Cleaning Belts
Changing Oil
Leveling the platter
5. Manuals
Horizon
Space Deck
Dais
Heavy Kit
Wave Mechanic
6. General Specs
Weights
Dimensions
7. Prices
8. Warranty information

Essential tools

Included

Allen Keys (metric)

Spirit Level

Protractor

Additional tools

- Stylus Pressure Gauge - The Shure SFG gauge works well
- Small Electric Screwdriver - With a clutch so you won't over tighten
- Cartridge Mounting Screws - Spares are helpful so when you drop them you don't have to go crazy looking for them
- A Good pair of Needle Nosed Pliers - Not Tweezers!
- A Ruler w/ Metric scale - At least 12 inches long
- A Good pair of Ears - Nothing will tell you more than listening to music

Set up Specs

Distance from Tone arm center to spindle

Interspace and RB-250	-	222 mm
Space Arm	-	210 mm
Anna (10")	-	222 mm
Anna (12")	-	294 mm

Effective Mass of Tone arms*

RB-250	-	11.25 grams
Interspace	-	11.25 grams
Space Arm	-	12.5 grams
Anna (10")	-	13 grams
Anna (12")	-	15.5 grams

* All measurements are approximate

Nottingham "Tracer One" cartridge specs

Cartridge Type	-	Moving Magnet
Output	-	5 millivolt – 5 cm/sec at 1KHz
Recommended Loading	-	47 K Ohm
Tracking Force	-	1.5 to 2.5 grams: Optimal 2.0 grams
Channel Balance	-	within 1.5 db at 1KHz
Channel Separation	-	More than 18 db at 1000 KHz
Dynamic Compliance	-	10×10^{-6} th cm/dyne
Stylus Tip	-	.6 mil Elliptical Diamond Stylus
Impedance	-	3200 ohms at 1000 Hz
DC Resistance	-	480 ohms at 1000 Hz
Weight	-	5 grams
Frequency Response	-	15 – 25,000 cycles

Set up tips

The meaning of tight

There is a great deal of debate about how tightly you should tighten all of the little screws and bolts when setting up a turntable. While we will not offer our thoughts on other manufacturers recommendations, we thought you should know about *our* recommendations for *our* turntable.

Tom Fletcher (Founder and head designer at Nottingham Analogue) says: “You should tighten just enough to hold in place. Our turntables are generally on the warm side of neutral, by tightening you have the ability to raise frequencies slightly. There are not many situations where this will help.” Over tightening things will raise the frequency of the turntable thereby exaggerating surface noise and making the table bright and strident.

Thoughts on VTA

Setting VTA causes a great deal of anxiety. I’ve never really understood why in light of the fact that no records are really the same thickness. Take a variety of records and listen.

Tom says: “Start with the arm parallel to the record. No diamond on the end of the styli is where it should be, so adjust the VTA up /down until you hear the best possible compromise. This is done in conjunction with the bias. Test records will *not* do the job for you, they may get you to the right haystack, but you will have to find the needle.”

Thoughts on Bias (anti-skate)

A good place to start is to set the stylus on the blank space between the lead out grooves. Adjust the bias weight until the stylus runs neither to the inside nor to the outside of the record. The dynamics of blank plastic are not the same as when the stylus is in the groove, so once you’ve done this add some bias, subtract some bias and listen.

Tom says: “On some cartridges, the bias mechanics can be used more beneficially if there are two small bias weights on the end of the lever. Some moving coils can need two bias weights, but these are the exception rather than the rule.” Call us at Audiophile Systems if you need additional weights.

Motor height

The motor height is adjustable and it is important to line up the grooves on the pulley with the grooves on the platter. Make sure the table is leveled first. If you need to raise or lower the motor, do so by pushing on the motor itself. It is snug in its housing, but it will move.

DO NOT PUSH ON THE PULLEY!

Installing and positioning the cartridge

My suggestion is to install the cartridge on the tone arm while the tone arm is free from the table. It will be much easier to attach wires and get the mounting screws threaded while the arm is free and on its back. Get the screws just snug enough to hold the cartridge in place but loose enough so that you can move it when you are lining things up with the protractor. Position the cartridge using the protractor, and then remove the tone arm again to snug the screws up (see section on “The meaning of tight”).

Getting the tone arm position right

Set the position of the tone arm using the distances listed in the chart found in set up specs. Do this before adding oil to the bearing well due to the fact that on some of the tables you will need to remove the platter to re-position the arm and tighten the arm pod back in place.

You may find that with certain cartridges you can optimize their set up by slightly repositioning the arm. This again is more easily done before the oil is added to the bearing.

Getting the right amount of oil in the bearing

Follow the recommendations on the set up sheet. Remember, though, that too much oil is better than too little. I take an absorbent paper towel, fold it, tear it half way across and position it around the spindle. Then, when the platter lowers into the bearing well (and some oil spills out), most of the overflow of oil will be caught by the towel. I usually spin the platter while it is settling. This seems to speed things up just a bit.

Positioning your table – (including leveling, mains connection)

Positioning your turntable (for that matter, your whole system) can have a major effect on your outcome. You must make sure that it is level. You should take care not to plug equipment into wall sockets that are connected to circuits that have dimmers, fluorescent lights or low voltage lighting (with its attendant transformers). Also be careful with fancy line conditioners. Some actually work, but most do not. Whenever you add anything to your system, listen carefully and judge by what you hear and feel, not by what you read in a magazine.

Tom says: “Sensible positioning of the turntable is required – special stands/platforms are sold for this very purpose but few succeed in any way shape or form! However, a few work very well – finding them can be difficult though. A wooden table will do the job very well. Try to divorce the turntable (physically and electrically) from big amps/transformers so you don’t undo all the work the turntable manufacturer is trying to do. Keep the table still and you will hear the music!”

What about the plinth

A plinth is supplied with each table. In the case of the Space Deck and the Horizon this is done to supply a platform with a predictable behavior. It is possible to use the tables without the plinth, but be careful! As we mentioned in the section above, many things that claim to do a “better” job, don’t. So listen.

The Dais requires the use of the plinth. There is a cutout for the motor that allows the motor to sit on the shelf below the plinth. This provides further isolation between the motor and the turntable. If you leave out the plinth, you will not be able to get proper height for the motor or proper isolation.

The other thing to keep in mind is that if you get way too much oil in the bearing it may overflow and drip onto your furniture. (Yeh, yeh, we all get the joke about British machinery leaking oil. Why do you never drive a British car without an oil spot under it? Because it must be out of oil.)

Maintenance & Service

Cleaning Belts

The belt should last a very long time. Occasionally you may want to clean it (especially if you have smokers in the house or if the house is dusty). All you have to do is wash it in some gentle liquid hand soap, rinse it carefully and let it dry.

Changing Oil

Tom Fletcher says: “Oil wears out under rotation – if the turntable is used *very* frequently, then change the oil every six months. If it is used once or twice a week (how most turntables are used) oil change is required only every 18 months to two years.”

You may also want to change oil if you haven't tried the new **Special Nottingham Analogue Kinetic Enhancement** oil. Believe it or not, this oil will improve the performance of your turntable. It has improved the performance of every turntable on which we have tried it.

Leveling the platter

Rarely, you may run across a platter that seems to wobble ever so slightly as it turns. On the Space Deck and the Horizon turntables the platter is held in place by three screws that are found under the mat and right around the spindle. You can correct these minor wobbles by tightening or loosening the three screws. Adjust to level the platter but be careful not to over-tighten. If you do not feel comfortable attempting this operation, contact Audiophile Systems.



NOTTINGHAM ANALOGUE STUDIO
128 CORDY LANE, UNDERWOOD, NOTTINGHAM NG16 5FD
Design and Manufacture of Quality Audio Equipment
Telephone: +(44) (0) 1773 762947
Fax: +(44) (0) 1773 533566
V.A.T. REGISTRATION NO. 667 3729 92

ASSEMBLY INSTRUCTIONS FOR THE HORIZON TURNTABLE

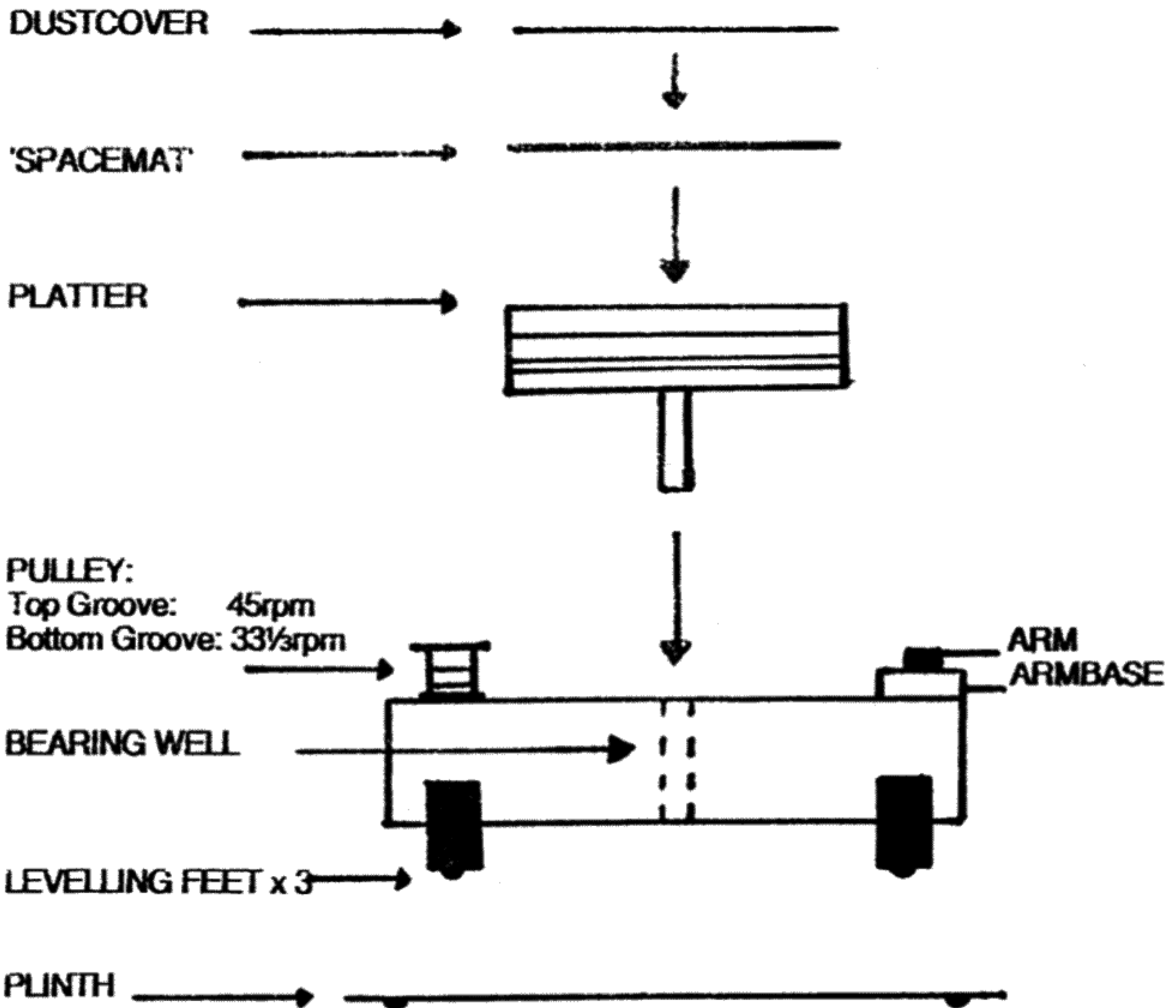

Put approximately $\frac{1}{2}$ of a capful of oil into the bearing well. Lower the platter assembly into the bearing well and allow it to settle. This may take a few minutes.

Place the drive belt provided around the platter and pulley using the appropriate grooves for the desired speed.

Fit the arm into the armbase and adjust using the protractor provided after you have fitted your choice of cartridge.

Happy Listening!



NOTTINGHAM ANALOGUE STUDIO
128 CORDY LANE, UNDERWOOD, NOTTINGHAM NG16 5FD

Design and Manufacture of Quality Audio Equipment

Telephone: +(44) (0) 1773 762947

Fax: +(44) (0) 1773 533566

V.A.T. REGISTRATION NO. 667 3729 92

ASSEMBLY INSTRUCTIONS FOR THE HORIZON SE TURNTABLE

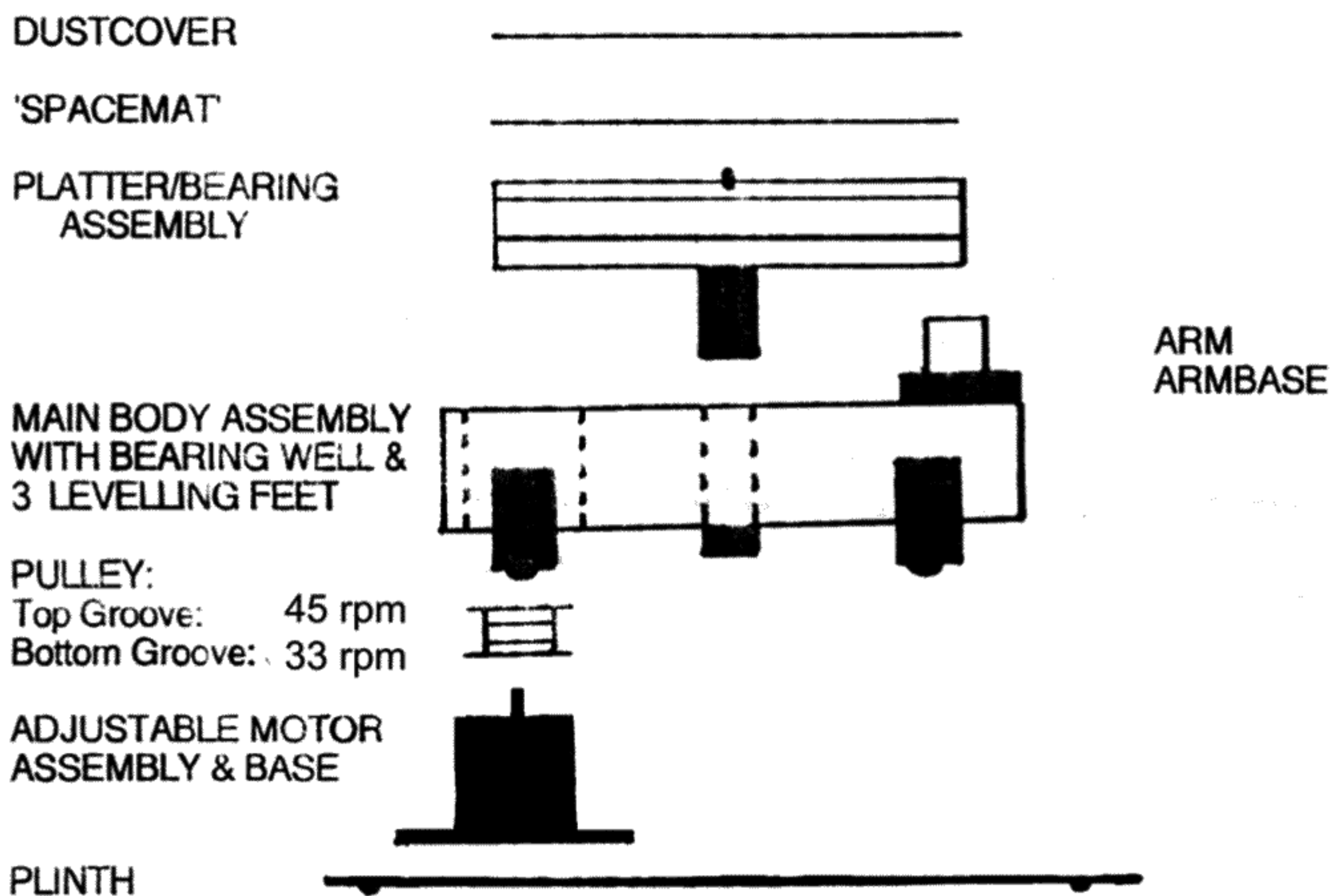

Put approximately $\frac{1}{2}$ of a capful of oil into the bearing well. Lower the platter assembly into the bearing well and allow it to settle. This may take a few minutes. Attach pulley onto motor spindle.

Place the motor/pulley assembly on the left side of the plinth with the cutout to the front and cable to the rear. The height can be adjusted by gently pushing the motor cassette up/down as required using hand pressure. **Do not adjust by pushing/pulling the pulley.**

VERY CAREFULLY lower the main body/platter assembly over the motor/pulley assembly. The cutout of the motor assembly base should be in line with the left leg of the main body, but not touching it. Using a combination of adjusting the motor cassette height and leveling feet, the platter and pulley can be lined up and leveled. Place the drive belt provided around the platter and pulley using the appropriate grooves for the desired speed.

Fit the arm into the armbase and adjust using the protractor provided after you have fitted your choice of cartridge.

Gently push the platter to start the turntable. It will adjust itself to the correct speed.

Happy listening!



NOTTINGHAM ANALOGUE STUDIO
128 CORDY LANE, UNDERWOOD, NOTTINGHAM NG16 5FD
Design and Manufacture of Quality Audio Equipment
Telephone: +(44) (0) 1773 762947
Fax: +(44) (0) 1773 533566
V.A.T. REGISTRATION NO. 667 3729 92

SPACEDECK INSTRUCTIONS

Place the turntable on a level surface. Half fill the bearing hole with oil. Carefully lower the platter assembly into the bearing well centrally and allow to sink slowly under its own weight. This can take several minutes. Level the turntable by the two adjusting feet. Place the motor up to the platter and align the two motor pulley grooves to coincide with the two bottom grooves in the platter by pushing the motor housing into the body up or down. If pushing down, **do not** push from the top of the pulley as motor damage may result. Place the belt around the bottom grooves of the platter and motor pulley. The bottom groove is 33 1/3 rpm and the top is 45 rpm.

Place the motor cut out groove by the static leg of the turntable without touching it and pull the motor body away from the leg to leave a gap of 6mm between the top of the pulley and the platter. Always use the turntable with the mat on. The plastic cover is a dust cover only. Do not touch the three caphead bolts on the top of the platter.

To start the turntable, give the platter a push by the thick rubber band. If pushed to fast, it will adjust to the correct speed in a few seconds. To stop the platter, gently place your hand on the thick rubber band.

Attach the cartridge to the arm and place the arm into the hole. The headshell should face directly to the front when the arm is 'parked'. Place the mat and an old record onto the platter. Position the arm so that it sweeps the whole of the record before hitting the 'stop'. Adjust the height and level with the small spirit level on top of the headshell. Tighten the two grub screws in the arm pillar. Align the cartridge and playing weight in the usual way. When using scales, place them directly onto the mat, not on the record. The adjustment of the playing-weight is set by moving the heavy bronze inner-weight. The bias is set by ear, but a rough guide is to lower the arm onto the runout groove of the record. It should stabilize before running gently into the center of the record. If the stylus moves quickly to the inside or outside of the record, the bias needs to be increased or decreased.

Note: if unable to get the correct cartridge adjustment, the armboard satellite can be adjusted by removing the platter and undoing the cap head bolt on the right side of the baseboard.



NOTTINGHAM ANALOGUE STUDIO
128 CORDY LANE, UNDERWOOD, NOTTINGHAM NG16 5FD
Design and Manufacture of Quality Audio Equipment

Telephone: +(44) (0) 1773 762947

Fax: +(44) (0) 1773 533566

V.A.T. REGISTRATION NO. 667 3729 92

SPACEDECK DIAGRAM

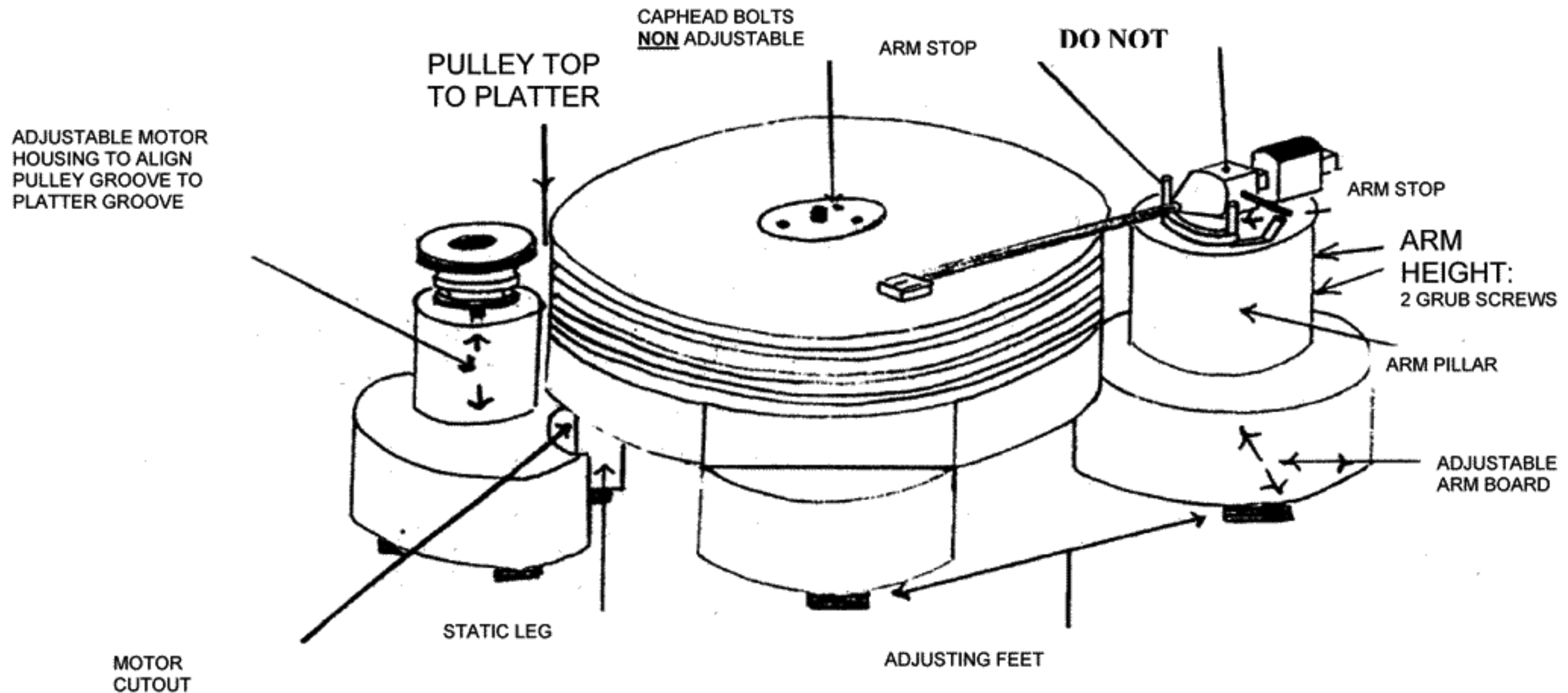



NOTTINGHAM ANALOGUE STUDIO
128 CORDY LANE, UNDERWOOD, NOTTINGHAM NG16 5FD
Design and Manufacture of Quality Audio Equipment
Telephone: +(44) (0) 1773 762947
Fax: +(44) (0) 1773 533566
V.A.T. REGISTRATION NO. 667 3729 92

HYPERSPACE INSTRUCTIONS

Place the turntable on a level surface. Put two capfuls of oil into the bearing well. Carefully lower the platter assembly into the bearing well centrally and allow to sink slowly under its own weight. This can take several minutes. After placing the main platter into the bearing well fit the plastic spacer over the spindle shaft, then gently lower the graphite top onto the main platter. Place the second rubber band in the groove between the main platter and the graphite top/ Level the turntable by the two adjusting feet.

Place the motor up to the platter and align the two motor pulley grooves to coincide with the two bottom grooves in the platter by pushing the motor housing into the body up or down. If pushing down, **do not** push from the top of the pulley as motor damage may result. Place the belt around the bottom grooves of the platter and motor pulley. The bottom groove is 33 1/3 rpm and the top is 45 rpm.

Place the motor cut out groove by the static leg of the turntable without touching it and pull the motor body away from the leg to leave a gap of 6mm between the top of the pulley and the platter. Always use the turntable with the mat on. The plastic cover is a dust cover only. Do not touch the three caphead bolts on the top of the platter.

To start the turntable, give the platter a push by the thick rubber band. If pushed to fast, it will adjust to the correct speed in a few seconds. To stop the platter, gently place your hand on the thick rubber band.

Attach the cartridge to the arm and place the arm into the hole. The headshell should face directly to the front when the arm is 'parked'. Place the mat and an old record onto the platter. Position the arm so that it sweeps the whole of the record before hitting the 'stop'. Adjust the height and level with the small spirit level on top of the headshell. Tighten the two grub screws in the arm pillar. Align the cartridge and playing weight in the usual way. When using scales, place them directly onto the mat, not on the record. The adjustment of the playing-weight is set by moving the heavy bronze inner-weight. The bias is set by ear, but a rough guide is to lower the arm onto the runout groove of the record. It should stabilize before running gently into the center of the record. If the stylus moves quickly to the inside or outside of the record, the bias needs to be increased or decreased.

Note: if unable to get the correct cartridge adjustment, the armboard satellite can be adjusted by removing the platter and undoing the cap head bolt on the right side of the baseboard.

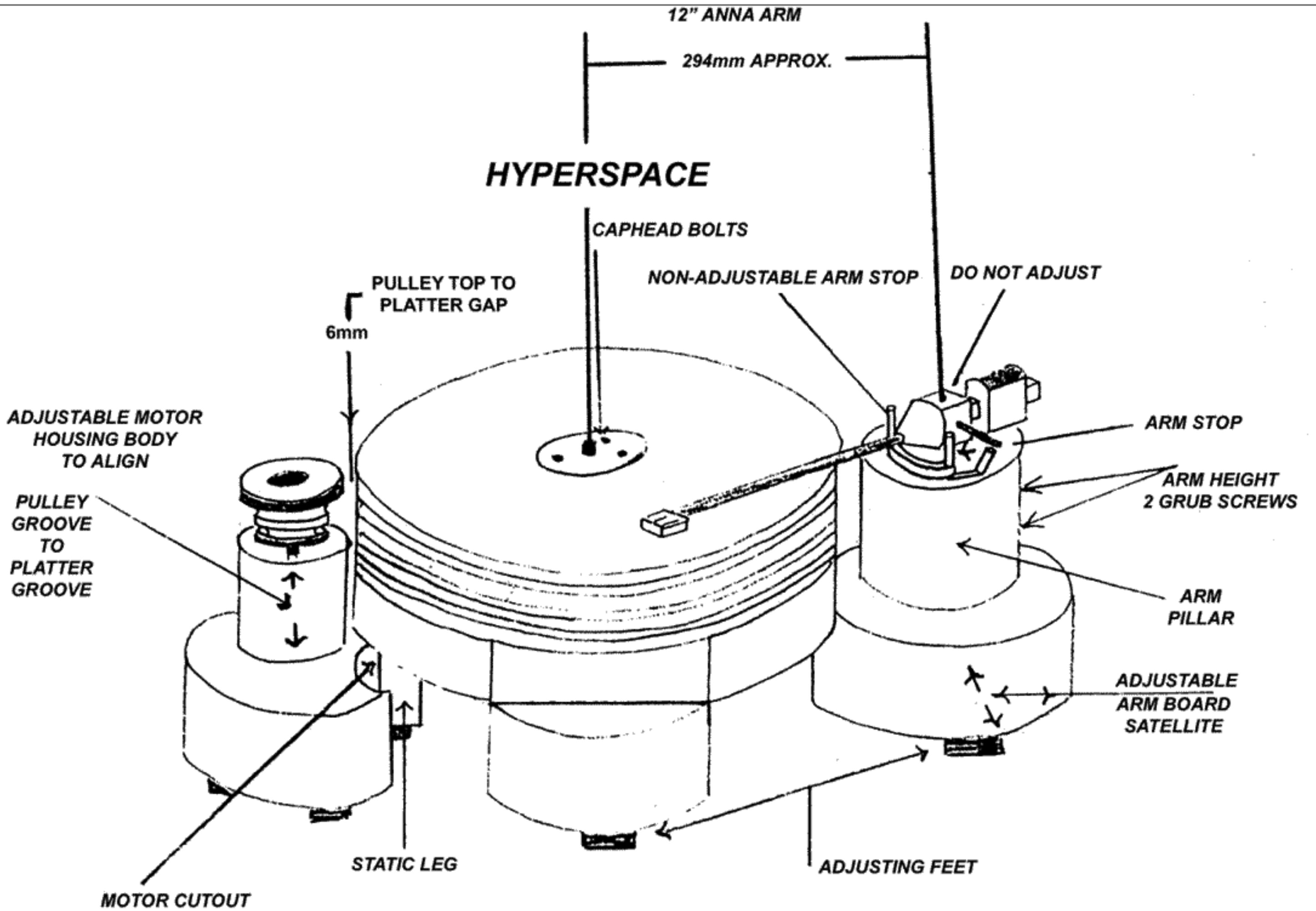



NOTTINGHAM ANALOGUE STUDIO
128 CORDY LANE, UNDERWOOD, NOTTINGHAM NG16 5FD

Design and Manufacture of Quality Audio Equipment

Telephone: +(44) (0) 1773 762947

Fax: +(44) (0) 1773 533566

V.A.T. REGISTRATION NO. 667 3729 92

DAIS INSTRUCTIONS

Well done, you have found the instructions! Now, carefully unpack both boxes. OK – we know it looks like a 'kit' to build a turntable. Put the plinth onto the surface you are going to use for your turntable with the 'U' shape cut out facing away from you. Put the motor into the 'U' shape with the lobe of the motor inside. Lift up the bearing chassis and you will find at the back a small 'u' shape cut out. This has to fit centrally around the motor, approximately 3mm away. With the spirit level provided, level the chassis with the three leveling feet. Carefully remove the sealing tape from around the bottom of the bearing. This will allow you to take the 'male' out of the 'female' part of the bearing. Half fill the bearing with the oil provided (do not worry if you slightly over fill it). Gently lower the male spindle into the hole and let it settle slowly down for a few minutes – it may take a long time to go right down, but it will reach its final level when the platter is put on.

Before placing the platter onto the bearing, make sure the mating surfaces are clean. Then, using the lifting handles provided, lower the platter very gently onto the bearing. Once the platter has settled, check the level again with the spirit level on top of the platter. Unscrew the lifting handles and gently place the graphite 'mat' on top of the platter. Place the drive belt around the platter and motor (top groove for 45rpm, bottom for 33 1/3rpm). Now you can fit your arm in the usual way. It is self-explanatory how to adjust the armboard 'lobes' with the tools provided.

Happy listening!



NOTTINGHAM ANALOGUE STUDIO
128 CORDY LANE, UNDERWOOD, NOTTINGHAM NG16 5FD
Design and Manufacture of Quality Audio Equipment
Telephone: +(44) (0) 1773 762947
Fax: +(44) (0) 1773 533566
V.A.T. REGISTRATION NO. 667 3729 92

ASSEMBLY INSTRUCTIONS FOR 'HEAVY DUTY KITS'

Remove the arm from the turntable.

Position the turntable satellite over the edge of a table. With the standard Allen key, undo the two headscrews under the armbase. Place the 25mm spacer in and re-connect the armbase to the satellite using the longer bolts provided.

Position the centre adapter in the middle of the turntable and gently lower the graphite platter onto the original platter. The damping ring is then placed in the groove between the original and the new graphite platters.

Replace and set up the arm.

Happy listening.

PLEASE NOTE: Due to the nature of the platter material, you may often find small imperfections in the top or bottom of the platter. This will make no difference to the function or the sound.



NOTTINGHAM ANALOGUE STUDIO
128 CORDY LANE, UNDERWOOD, NOTTINGHAM NG16 5FD
Design and Manufacture of Quality Audio Equipment
Telephone: +(44) (0) 1773 762947
Fax: +(44) (0) 1773 533566
V.A.T. REGISTRATION NO. 667 3729 92

WAVE MECHANIC POWER SUPPLY

Why a power supply? But first, why an AC turntable motor?

Nottingham Analogue turntables excel by virtue of their almost elemental simplicity, relying as they do on the fact that a rotating platter will continue to do so at absolutely constant speed unless acted upon by outside forces. By coupling this steadily rotating mass to an arm base that is stable around the axis of rotation of the platter, the result is a truly integrated unit.

By giving the platter adequate moment of inertia, the effects of any variability in outside forces are minimized. However, the most important force, bearing friction, should if the bearing is correctly made and lubricated remain essentially constant; hence, all that is required is to supply a small amount of energy to the platter at a constant rate – just sufficient to counter the friction and maintain a steady speed.

DC motors and their highly developed control systems may rightly dominate the small motor market for “movement and placement” applications such as robotics, but are they what we need in order to maintain this steady state? For this purpose, an AC synchronous motor backed by the “mass” of the National Grid should be the answer. Unfortunately, although the laws of mechanics show no sign of changing, electricity supplies are – and apparently always for the worse. There are four main areas of concern.

1. Voltage variations

As a case in point, since “harmonizing” with the rest of the EC, the nominal UK domestic supply voltage has fallen from 240V to 230V, but the permissible range of voltage has increased vastly, now being from –6% (216.2V) to +10% (253V). This whole range will not be seen in any one locality, but wide variations do occur between different areas.

For an AC synchronous motor, such voltage variations will not affect its overall speed, but will affect its torque: not what we need for constant energy input (torque x speed = power). In addition, the absolute voltage level has a very distinct effect on the dynamics and detail of the music, with a clearly audible optimum voltage range. We need, then, to be able to optimize the motor supply voltage and to hold it stable.

2. Frequency variations

These, by definition, will directly affect the speed of a synchronous motor. Supply frequency variations are generally slow, but are easily demonstrated using an independent precision strobe illuminator such as the “Zapper”.

Permissible variation in the UK is +/- 1% (6% equates to a semitone). Over 24 hours the frequency must average exactly 50Hz to satisfy users of synchronous clocks, so that if the frequency is slow at one point in the 24 hours, it must be fast at some other point as night follows day (sometimes literally!). For a power supply, some slight adjustment of frequency is desirable for pitch purposes but once set, it must remain stable.

3. Supply waveform

This is an aspect that has been becoming universally and insidiously more of a problem over the years largely as a result of the “switched mode” power supplies that have generally supplanted transformers in much modern electronic equipment.

The supply waveform does not now have a clean sinusoidal shape, but shows drastically clipped peaks – the equivalent of adding numerous high order harmonics to the fundamental 50 or 60 Hz. These can be shown to exist at significant levels far up into the audio frequency range, and even if attenuated by damping in the drive belt will still feed through to the platter. We need to synthesize a new clean waveform; “filtering” is not an answer.

4. Voltage spikes, and other “hash”

These are another part of the fallout from the volume and complexity of modern consumer demands, and are sufficiently worrying to have provoked restrictive regulations on equipment manufacturers. Our AC motor supply needs to be free of all such intrusions.

THE WAVE MECHANIC

The “Wave Mechanic” power supply addresses all of these issues, and provides a clean waveform, stable in voltage and frequency even when run off voltages well below the permissible level. The output voltage is pre-set internally to be in the optimum range, and there is a single control on the front panel to allow minor adjustment of the frequency for pitch control. Other than for this purpose it will probably remain untouched.

Both 50Hz and 60Hz version are available configured to suit local frequency and voltage.

For a Turntable speed reference to partner the “Wave Mechanic” power supply, the “Zapper” hand-held battery-operated strobe illuminator is ideal. This is available in 50Hz and 60Hz version, either with the power supply or separately for more general use.

The audible benefits of the power supply are very clear. Detail, dynamics and sound stage are all much improved, but perhaps the most evident feature is the way that the whole pace and rhythm of the music sound natural and true. Pitch stability is impeccable, giving complete confidence and much deeper involvement in the musical performance.

The benefits should not be expected to replace those from upgrading the turntable, but rather to complement them. All of the Nottingham Analogue turntables will benefit, whether your current one or your next upgraded one!

Specifications:

Supply voltage/frequency: Version for 230V/50Hz, 115V/60Hz, 100V/50Hz, 100V/60Hz

Power consumption: 6.5W

Fuse: Ceramic HRC 5mm x 20mm T250mA (230V), T500mA (115V and 100V)

Output frequency: 50Hz or 60Hz (depending on model) with control in center position.

Case Dimensions: (H x W x D) 2.55” x 4.13” x 11.22”

Weight: (w/ packaging) 5.6 lbs.



NOTTINGHAM ANALOGUE STUDIO
128 CORDY LANE, UNDERWOOD, NOTTINGHAM NG16 5FD
Design and Manufacture of Quality Audio Equipment
Telephone: +(44) (0) 1773 762947
Fax: +(44) (0) 1773 533566
V.A.T. REGISTRATION NO. 667 3729 92

Pulley Installation

An adjustment has been made to the packing of Nottingham's turntables to ensure that the motor/pulley assembly can better withstand the rigors of shipping in the United States. Follow these steps to properly affix the pulley to the motor:

1. Locate the pulley (fig. 1)
2. Locate the motor (fig. 2)
3. Slide the hole in the bottom of the pulley (fig. 3) over the post at the center of the motor, and press down until the pulley stops.

When the turntable is spinning, if you notice rubbing at the bottom of the pulley, simply pull up on the pulley to eliminate any contact with the motor housing.

Figure 1



Figure 2

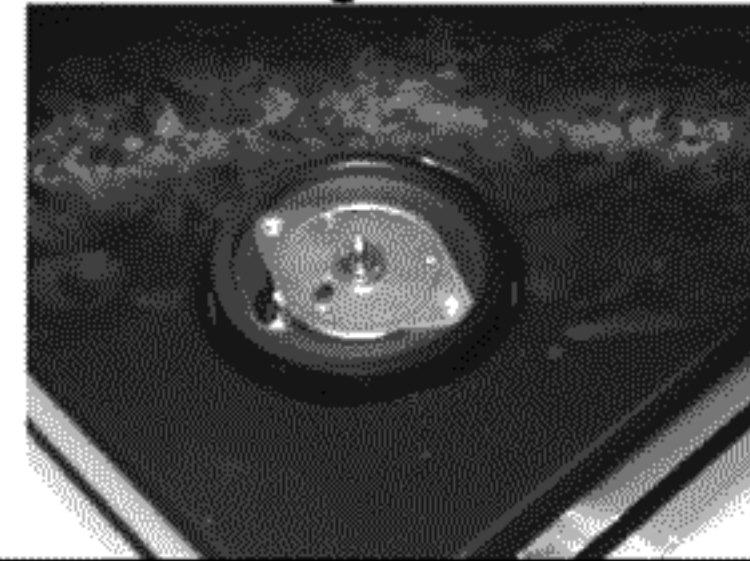
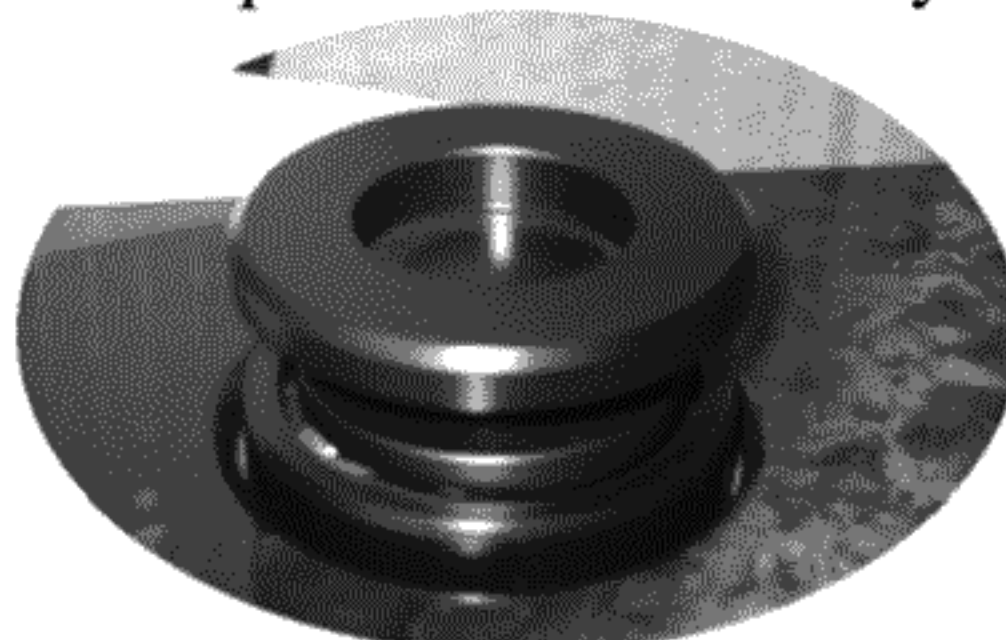

Figure 3



Completed motor assembly





NOTTINGHAM ANALOGUE STUDIO
128 CORDY LANE, UNDERWOOD, NOTTINGHAM NG16 5FD

Design and Manufacture of Quality Audio Equipment

Telephone: +(44) (0) 1773 762947

Fax: +(44) (0) 1773 533566

V.A.T. REGISTRATION NO. 667 3729 92

Rega Tonearm Instructions

With the cartridge fitted and aligned using the alignment protractor supplied, ensure that the bias adjustment slider is set to zero. Screw the balance weight along its shaft until the stylus is 'floating' just 1mm clear of the record.

The recommended tracking force can now be applied by rotating the balance weight so that it moves toward the front of the arm. One half-turn gives 1g of tracking force. The green plastic plugs on the weight can be used as a visual aid to achieve this. Always use a force that corresponds to the upper limit of the cartridge maker's recommended range.

Set the bias adjustment slider to the same number as the tracking force control, i.e.

1 ½g tracking force=1 ½ on the bias slider.

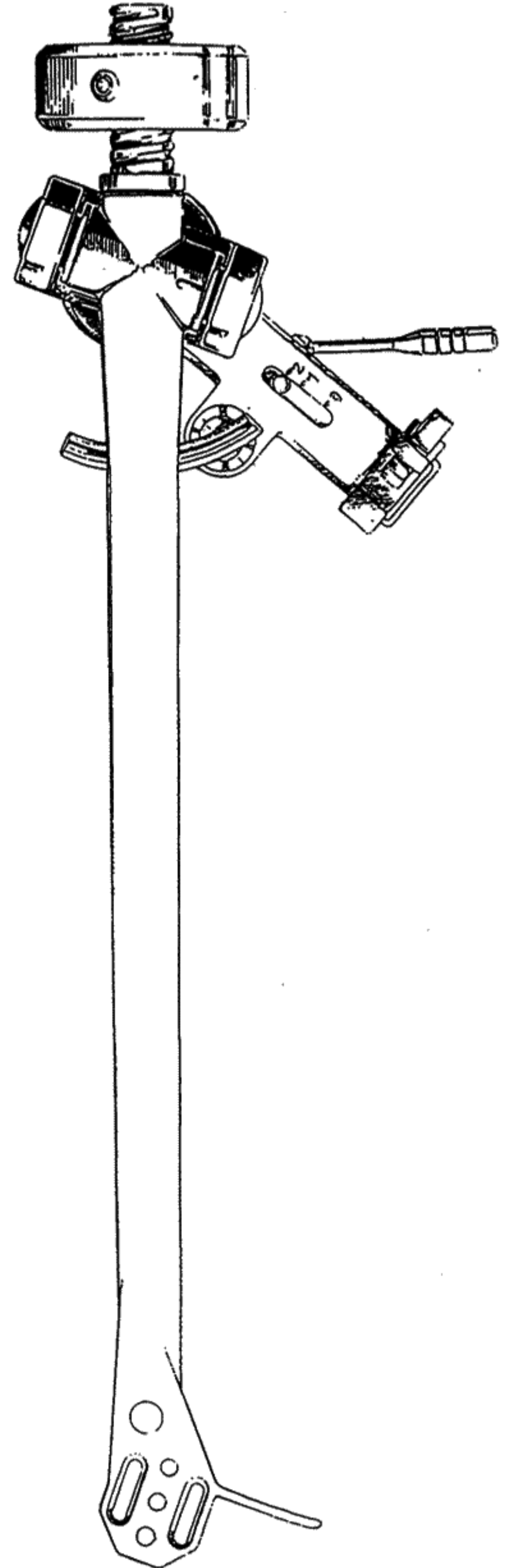



NOTTINGHAM ANALOGUE STUDIO

128 CORDY LANE, UNDERWOOD, NOTTINGHAM NG16 5FD

Design and Manufacture of Quality Audio Equipment

Telephone: +(44) (0) 1773 762947

Fax: +(44) (0) 1773 533566

V.A.T. REGISTRATION NO. 667 3729 92

INTERSPACE ARM INSTRUCTIONS

Place the arm in the collet facing forward. Carefully put the stylus into the cartridge body and raise the arm out of the collet. With the small spirit level placed forward on top of the headshell, set the arm level on top of the record. Lock up the small grub screws with the Allen key provided. The screws are situated on the right side of the arm board. Check the cartridge alignment with the protractor provided. Tracking weight is set with the mat in place, but not the record. The bias can now be set. The plastic weight carrier must hang straight when final adjustment of weight is achieved.



NOTTINGHAM ANALOGUE STUDIO
128 CORDY LANE, UNDERWOOD, NOTTINGHAM NG16 5FD
Design and Manufacture of Quality Audio Equipment
Telephone: +(44) (0) 1773 762947
Fax: +(44) (0) 1773 533566
V.A.T. REGISTRATION NO. 667 3729 92

SPACEARM and ANNAARM INSTRUCTIONS

Attach the cartridge to the arm and place the arm into the hole. The headshell should face directly to the front when the arm is 'parked'. Place the mat and an old record onto the platter. Position the arm so that it sweeps the whole of the record before hitting the 'stop'

With the arm set to the proper tracking force, adjust the arm in its mount so that the arm is parallel to the surface of an LP on the platter. Snug one of the arm lock screws in the arm base and turn the VTA adjustment screw until it just touches the arm base.

Loosen the arm lock screw and turn the VTA adjustment screw counter clockwise a couple of turns so that the back of the arm is definitely too low and snug up the arm lock screw just enough that when the VTA adjustment screw is turned clockwise it will raise the back of the arm.

Play a record in this setting then turn the screw clockwise in ½ turn increments. The sound will continue to improve to a point then it will start to sound worse with subsequent turns. Go back the number of half turns where it sounded best and then loosen the snug arm lock screw so that the arm settles to the height of the VTA adjustment screw. Tighten both arm lock screw (not too tight!) and enjoy.

Tighten the two grub screws in the arm pillar. Align the cartridge and playing weight in the usual way. When using scales, place them directly onto the mat, not on the record. The adjustment of the playing-weight is set by moving the heavy bronze inner-weight. The bias is set by ear, but a rough guide is to lower the arm onto the runout groove of the record. It should stabilize before running gently into the center of the record. If the stylus moves quickly to the inside or outside of the record, the bias needs to be increased or decreased.

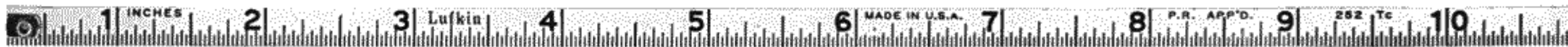

Polaris Plus Stylus Alignment Gauge (standard pattern)



Pivot to Stylus:

Anna Arm 12" = 294mm (11 37/64 in.)

Anna Arm 10" = 222mm (8 1/4 in.)

Spacearm = 210mm (8 17/64 in.)

Interspace Arm = 210mm (8 17/64 in.)

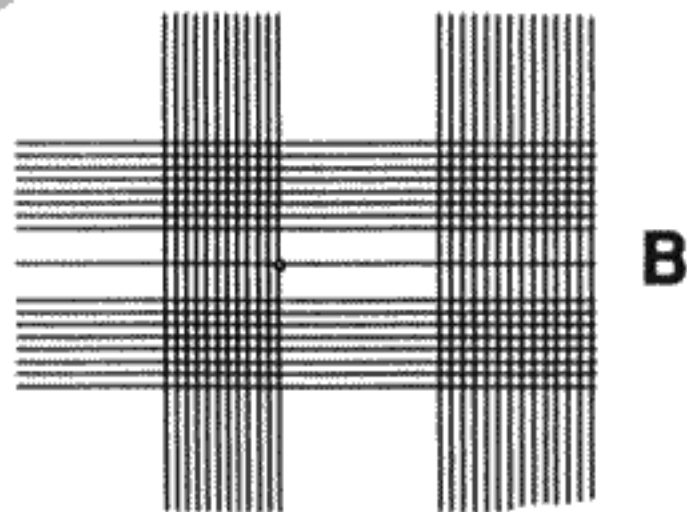

1. Initially mount the cartridge midway in the headshell slots.
2. Level the 'playing field'; set a nominal tracking force and arm height, and zero the bias ('antiskating') force.
3. Slip hole 'A' of the gauge over the turntable spindle.
4. Point the arrow directly at the vertical pivot axis of the arm.
5. Adjust the cartridge position and angle such that the stylus sits in the center of the small circle on line 'B', and the cantilever (viewed from the front) lies exactly above and along line 'B'. If you cannot see the cantilever well enough for sighting, then align the cartridge body to the grid. **Make sure the arrow is still on target!**
6. Re-adjust the tracking force, and if necessary, repeat step 5.
7. (optional) Confirm the setting using hole 'C' instead of hole 'A'. Please note that the alignment of hole 'A' is far more accurate and critical.
8. Set the bias force, and perfect this together with the tracking force and V.T.A. (arm height) by listening.

General Specifications

<u>Model</u>	<u>Dimension (w/d/h inches)</u>	<u>Weight / Shipping Weight</u>	
Deco	20 x 18 x 9.5	99	140
Dais	19 x 15 x 12	66	109
Hyperspace	19 x 15 x 10	55	86
Space w/ heavy kit	18 x 14.25 x 8	47	63
Space Deck	18 x 14.25 x 8	38	50
Horizon SE	19 x 13.25 x 7.25	22	35
Horizon	19 x 13.25 x 7.25	22	35

Nottingham Arm Boards

Following you will find a grid for specifying and ordering mounting systems for the most commonly requested tonearms for each of the Nottingham Analogue turntables. All information is based on the assumption that the turntable in question is a current model and is equipped with the standard mount for a Nottingham tonearm. ALL exceptions must be noted. Be aware that older Space Decks and Hyperspace Decks have thinner platters which require a different set up.

Please be advised that the following information is accurate only for standard length arms that are currently in production. ALL tonearms not listed must be quoted individually.

ALL 12 inch versions of these arms are exempt and must be quoted individually.

When ordering you MUST specify the model number of the specific tonearm and whether you intend to mount it on the right or left hand side of the table. All left hand mounts will require complete pods for Space Decks and Hyperspace Decks unless you are replacing an arm currently on a left hand POD.

ARMBASE INFORMATION

Use this Chart to determine the hardware required to mount the following common arms on tables fitted with Nottingham Arms or arm mounts

Turntable	Rega	SME	Graham 2.2	Morch *	Hadcock
Horizon & Horizon SE Right side only	Collet	Arm base	Arm base	Collet	Arm base
Interspace Right or Left side	Collet	Arm base	Arm base	Collet	Arm base
Space & Space Heavy Right side Left side	Collet Pod	Arm base Pod	Arm base Pod	Collet Pod	Arm base Pod
Hyperspace Right Side Left side	Collet Pod	Arm base Pod	Arm base Pod	Collet Pod	Arm base Pod
Dais or Anna Log Right side Left Side	Collet Arm base	Arm base Arm base	Arm base Arm base	Collet Arm base	Arm base Arm base
Deco Right side Left side	Collet Arm Base	Arm base Arm base	Arm base Arm base	Collet Arm base	Arm base Arm base

* (15&20)
mm
Arm pillars

Prices*

Retail

Collets:

Rega	\$50.00
Morch	\$75.00

Arm Base:

Horizon / Horizon SE	\$375.00
Interspace	\$180.00
Space & Space Heavy	\$220.00
Hyperspace	\$375.00
Dais / Anna Log	\$220.00
Deco	\$375.00

Complete Pod:

Space & Space Heavy	\$430.00
Hyperspace	\$595.00

* Prices are for Standard Length arms only - 12 inch versions require individual quotes