

SERVICE MANUAL

NAD Model 90

STEREO AMPLIFIER

copy

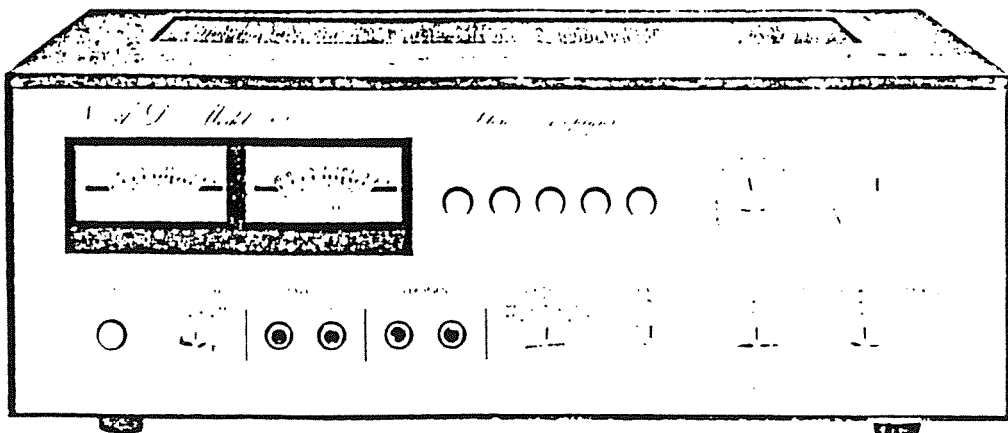

2. BIAS ADJUSTMENT PROCEDURE

The proper bias adjustment is most important to assure correct performance of the amplifier. Bias adjustment is necessary if any of the transistors are replaced in the power amplifier circuitry or the amplifier exhibits overheating of the output transistors under normal operating conditions.

INDICATOR	ADJUSTMENT	REMARKS
DC Voltmeter	VR601a, b (1 Kohm)	Adjust for 0.006 – 0.015 V across R624a, b (0.33 ohm) with NO SIGNAL

REMARK: Bias can also be adjusted by using a line wattmeter. Adjust the VR601a and VR601b to the point at which the line wattmeter shows very slight increase.

3. ADJUSTMENT AND CHECK POINTS

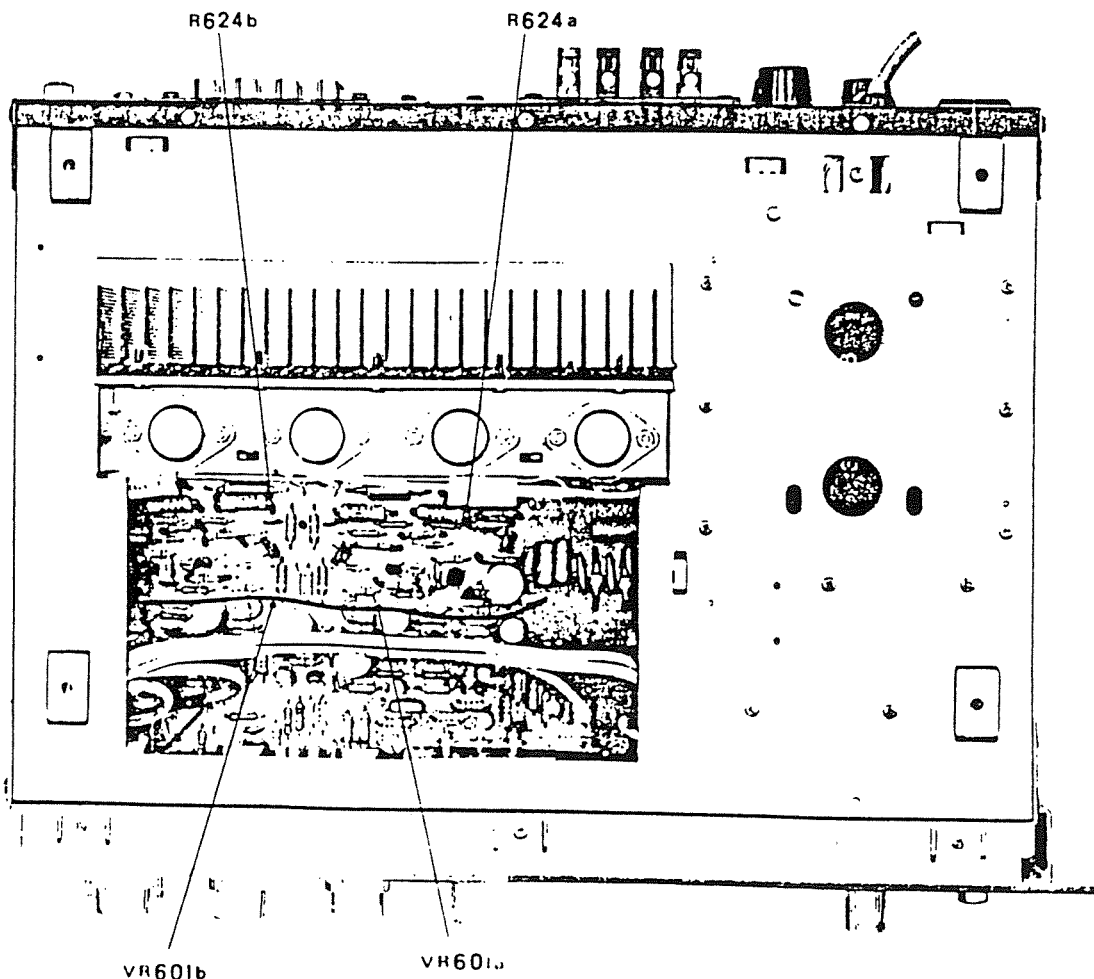

15. SCHEMATIC DIAGRAM

N.S.D. Model 90
Stereo Amplifier

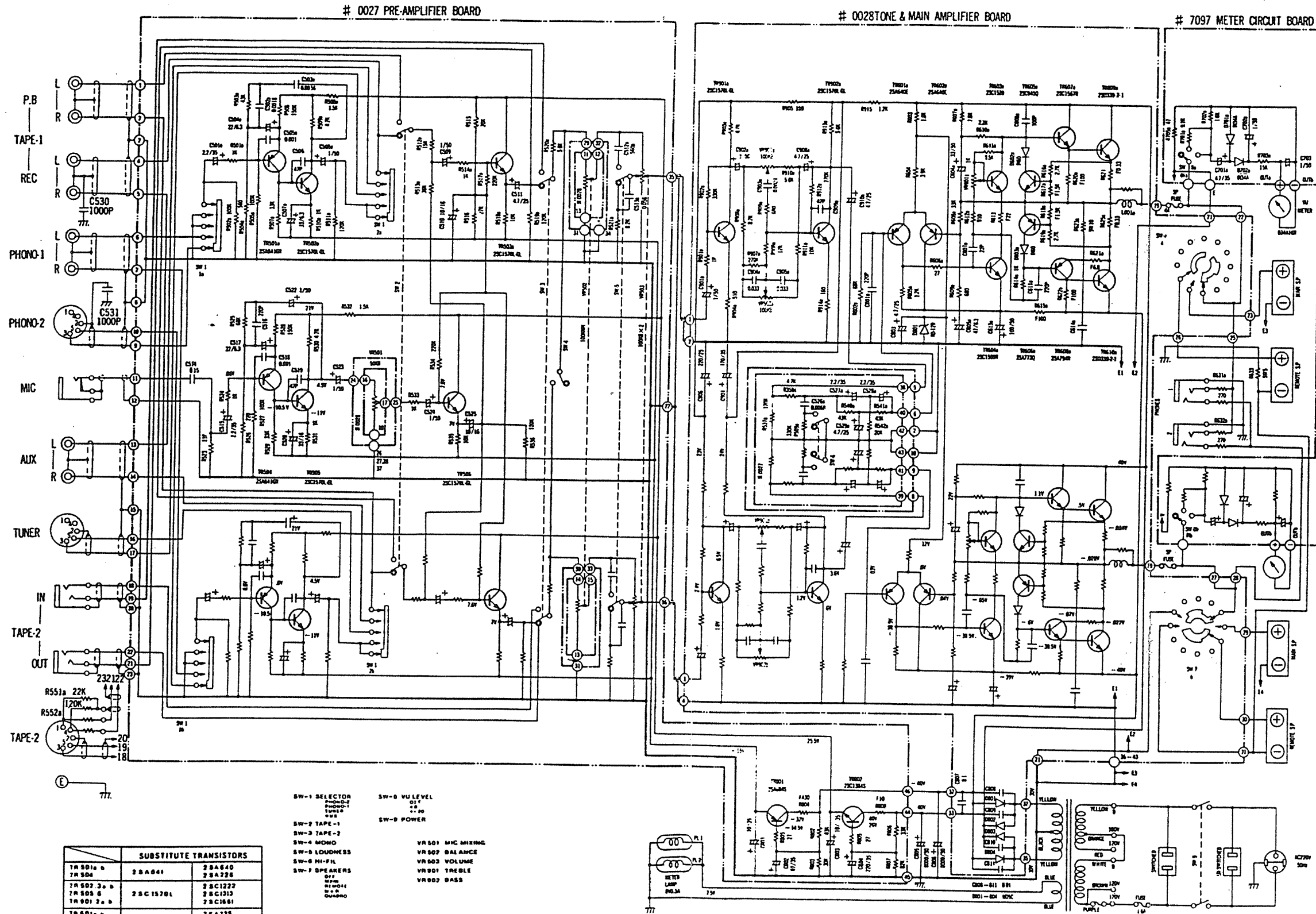

SUBSTITUTE TRANSISTORS		
TR 801a, b	2SA841	2SA840
TR 804	2SA228	
TR 807 3a, b	2SC1227	
TR 805 6	2SC1513	
TR 801 7a, b	2SC1661	
TR 801a, b	2SA840	2SA775
TR 802a, b	2SA841	2SA641
TR 803a, b	2SC1539	NONE
TR 804a, b	2SC1508	2SD439
TR 805a, b	2SC845	2SC863
TR 806a, b	2SA753	2SA841
TR 807a, b	2SC1567	2SC1174 2SD415
TR 808a, b	2SA784	2SA708 2SD349
TR 809a, b	2SD339	2SD397 2SD332
TR 801	2SA684	2SA775
TR 802	2SC1384	2SC1475

- SW-1 SELECTOR
- SW-2 TAPE-1
- SW-3 TAPE-2
- SW-4 MONO
- SW-5 LOUDNESS
- SW-6 HI-FIL
- SW-7 SPEAKERS
- SW-8 VU LEVEL
- SW-9 POWER
- VR 801 MIC MIXING
- VR 807 BALANCE
- VR 803 VOLUME
- VR 801 TREBLE
- VR 802 BASS

TRANSISTOR CONNECTIONS											
TR 801a, b TR 804	TR 801a, b TR 802a, b	TR 805a, b	TR 806a, b	TR 801	TR 804a, b	TR 803a, b	TR 803a, b	TR 807 3a, b TR 805 6 TR 801 7a, b	TR 808a, b TR 809a, b	TR 802	TR 802a, b

1. Resistance values are indicated in ohms unless otherwise specified (K=1,000, M=1,000,000).
2. Capacitance values are shown in microfarads unless otherwise noted (P= micro-microfarads).
3. DC voltages are reference to ground under the following conditions:
No signal
() 1,000µV FM stereo signal
4. Numbers shown in circles are pin points

Transistors.

Powerboard :

TR601a	A640	BC560
TR601b	A640	BC560
TR 602b	BC560	hfe 498
TR 602a	BC560	hfe 498
TR 604b	2SC3328 (y)	hfe 144
TR 604a	2SC3328	hfe 144
TR 605b	C945	hfe 242
TR 605a	C945	hfe 246
TR 606b	A733	hfe 338 new
TR 606a	A733	hfe 338 new
TR 607b	BD 139	hfe 110
TR 607a	BD 139	hfe 110
TR 608b	BD140	hfe 117
TR 608a	BD 140	hfe 117
TR 901b	BC550	hfe 580 new
TR 901a	BC550	hfe 580 new
TR 902b	BC550	hfe 594 new
TR 902a	BC550	hfe 594 new

Tone control board

TR 501a	BC 560	Hfe 542 new.
TR 501b	BC 560	Hfe 546 new
TR 502a	C1570 (G)	Hfe 339
TR 502b	C1570 (G)	Hfe 339
TR 503a	BC550	Hfe 651 new
TR 503b	BC550	Hfe 651 new
TR 504	BC560	Hfe 547 new
TR 505	BC550	Hfe 607 new
TR 506	BC550	Hfe 607 new
TR 801	2SA684	hfe 200
TR 802	2SC1384	hfe 200

C1570 =BC 550
A640 = BC 560
A841 = BC 560
A733 = BC 557
C945 = BC 182

Ceramic caps.

Tone board.

C514 = 154k = 150000 pf = 150nF = 0,15 uF = MKT 0,15

C503b = 562k = 5600pf = 5,6nF

C503a = 562k = 5600pf = 5,6nF newtone

C519 = 47pf

C506b = 47pf

C506a = 47pf

C502a = 182k = 1800 pf = 1,8nf

C503b = 182k = 1800pf = 1,8nf

C505a = ,001k = 0,001uf = 1 nf newtone

C505b = ,001k = 0,001uF = 1nf

c518 = ,001k = 0,001uf = 1nf

C516 = 220pf newtone

c 512a = 560 = 560pf

c512b = 560 = 560pf

c513a = 563k = 56000 pf = 56nf ebay 2,50

c513b = 56nf0 = 56000pf = 56nf

C526a = .0068 = 0.0068uf = 68nf

C526b = .0068 = 0.0068uf = 68nf

powerboard :

C608b = 100pf

c 608a = 100pf

c904a = 333k 33000pf = 33nf

c 904b = 333k 33000pf = 33nf

c909b = 47 pf

c909a = 47 pf

c 905 a = 333k 33000pf = 33nf

c905 b = 3335 33000pf = 33nf

c 903a = ,0027k 0,0027 uf = 2,7 nf

c903b = ,0027k 0.0027uf = 2,7nf

c601a = 220pf

c 601b = 220pf

c607a = 22pf-*+

c607b = 22pf

c611a = 220pf

c611b = 220pf

c808-811 = ,01uF 4x = 10nF