

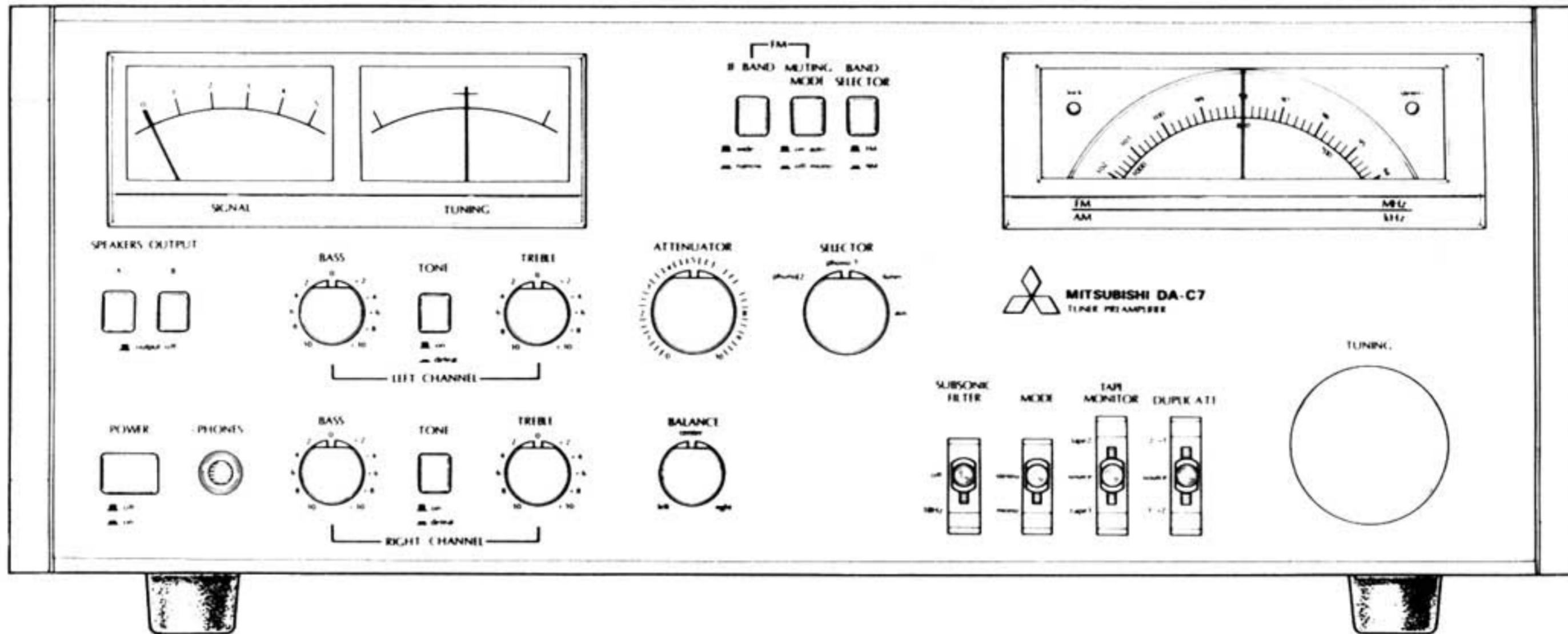

SERVICE MANUAL  
**TUNER-PREAMPLIFIER**  
MODEL **DA-C7**



**MELCO SALES INC.**  
3030 East Victoria Street Compton, California 90221

## SPECIFICATIONS

### 1-(1) FM TUNER SECTION (IHF)

Usuable sensitivity	
MONO	11.2dBf (2.0 $\mu$ V)
STEREO	23.1dBf (7.8 $\mu$ V)
50dB quieting sensitivity	
MONO	20dBf (5.5 $\mu$ V)
STEREO	40dBf (55 $\mu$ V)
Signal to noise ratio	
MONO	76dB
STEREO	73dB
Frequency response	+0.5 dB from 30Hz to 16kHz -1.0
Total harmonic distortion (at 1kHz, 65dBf)	
MONO	0.08% (WIDE) 0.25% (NARROW)
STEREO	0.1% (WIDE) 0.5% (NARROW)
Capture ratio	1.0dB (WIDE) 2.0dB (NARROW)
Alternate channel selectivity	50dB (WIDE) 75dB (NARROW)
Spurious response ratio	70dB
Image response ratio	60dB
IF response ratio	80dB
AM suppression ratio	50dB (WIDE) 40dB (NARROW)
Stereo separation	
WIDE	45dB at 1kHz, 40dB at 10kHz
NARROW	35dB at 1kHz, 30dB at 10kHz
Subcarrier product ratio	60dB
SCA rejection ratio	70dB
Tuning range	88MHz to 108MHz

### 1-(2) FM TUNER SECTION (DIN)

Sensitivity (at 40kHz deviation)	
MONO (S/N 26dB)	1.2 $\mu$ V
STEREO (S/N 46dB)	32 $\mu$ V
Image frequency rejection (at 98MHz)	60dB
IF rejection (at 98MHz)	80dB
Spurious rejection (at 98MHz)	70dB
AM suppression	50dB (WIDE) 40dB (NARROW)
Selectivity (at 40kHz deviation, $\pm$ 300kHz)	45dB (WIDE) 70dB (NARROW)
Signal to noise ratio (at 40kHz deviation)	
MONO	75dB
STEREO	68dB

Total harmonic distortion (at 1kHz deviation)	
MONO	0.08% (WIDE) 0.25% (NARROW)
STEREO	0.1% (WIDE) 0.5% (NARROW)
Stereo separation (at 1kHz, 40kHz deviation)	35dB (NARROW)
Frequency response	+ 0.5 dB from 30Hz to 16kHz - 1.0

### 2-(1) AM TUNER SECTION (IHF)

Usable sensitivity (bar antenna)	200 $\mu$ V/m
Selectivity	25dB
Total harmonic distortion	1.0%
Image response ratio	40dB
IF response ratio	40dB
Hum and noise	50dB
Tuning range	525kHz to 1605kHz

### 2-(2) AM TUNER SECTION (DIN)

Selectivity (bar antenna, at 30% modulation S/N 25dB)	300 $\mu$ V/m
Signal to noise ratio (at 5mV/m, 30% modulation)	50dB
Selectivity (at $\pm$ 9kHz)	25dB
Image frequency rejection (at 1MHz)	40dB
IF rejection (at 1MHz)	70dB
Total harmonic distortion (at 30% modulation)	1.0%

### 3 PREAMPLIFIER SECTION

Input sensitivity/impedance	
PHONO 1, PHONO 2	2.5mV/50k ohms
AUX, PLAY 1, PLAY 2	150mV/50k ohms
Output level/impedance	
OUTPUT	1V (rated output)/600 ohms 10V (maximum output)
REC 1, REC 2	150mV/600 ohms
PHONES (8 ohms)	600mV(at output 1V /15 ohms ) 650mV (maximum output) (headhone impedance from 8 ohms to 16 ohms)
Equivalent input noise level (IHF, A network)	
PHONO 1, PHONO 2	-127dB(V) (closed circuit)
AUX, PLAY 1, PLAY 2	-115dB(V) (closed circuit)
Signal to noise ratio (IHF, A network, at rated output)	
PHONO 1, PHONO 2	75dB (closed circuit)
AUX, PLAY 1, PLAY 2	99dB (closed circuit)
Signal to noise ratio (DIN)	
PHONO 1, PHONO 2	69dB (2.2k ohms terminated)
AUX, PLAY 1, PLAY 2	88dB (47k ohms//250pF terminated)
Total harmonic distortion	
(at rated output attenuator -20dB, 1kHz)	
PHONO 1, PHONO 2	0.003%
AUX, PLAY 1, PLAY 2	0.003%

Frequency response	
PHONO 1, PHONO 2	±0.2dB from 20Hz to 20kHz (RIAA STD)
PLAY 1, PLAY 2	+ 0 -0.5 dB from 10Hz to 70kHz
Tone control	
BASS	±10dB at 100Hz
TREBLE	±10dB at 10kHz
Subsonic filter	18Hz (-6dB/oct)
Phono overload level (at 1kHz with 0.1% THD)	
PHONO 1, PHONO 2	100mV

#### 4 GENERAL

Power consumption	25W
Dimensions (W x H x D)	425 x 170 x 292 mm (16-3/4 x 6-3/4 x 11-1/2")
Weight	7.5kg (16-1/2 lbs)
Supplied with;	T shaped antenna

**Design and specifications are subject to change without notice for improvements**

## SERVICING NOTES

### 1. Before connection, turn off the power supply at all times

Otherwise, the speakers are liable to be damaged by click noise caused when the cord is plugged in or out.

### 2. Avoid improper connection

When turntable, tuner, and R and L output terminals of this machine are incorrectly connected or short-circuited, damage to the unit may result.

### 3. Correctly make input terminal connection

If pin plug or ground wire of record player output cord is loosely connected or disconnected, hum occurs. Note that the speaker is liable to be damaged as a result of this induced hum.

### 4. Use shielded wire for input terminal connection

Use a shielded wire of not more than 2 m long for connections to record player. In this case, avoid the use of longer shielded wire which causes deterioration of high frequency characteristics and may cause an increase in hum and noise.

### 5. Use the short-circuiting pin plugs provided in the unused PHONE terminal

This is intended to prevent open noise, and click noise caused when the input selector is switched without connecting a turntable. When you use Mitsubishi DA-A7DC, DA-A10DC, or DA-A15DC in combination with this machine, power of the power amplifier must be supplied from SWITCHED plug sockets of this machine. The speaker control cord is used only with Mitsubishi power amplifiers.

## DISASSEMBLING

### 1. Removal of the Top Plate and the Bottom Cover

- 1) After removing the two screws indicated as A in Fig. 1, take off the top plate pulling it backwards.
- 2) The bottom cover is removed by taking off the two screws indicated as B in Fig. 1 as well as the two screws located at the bottom.

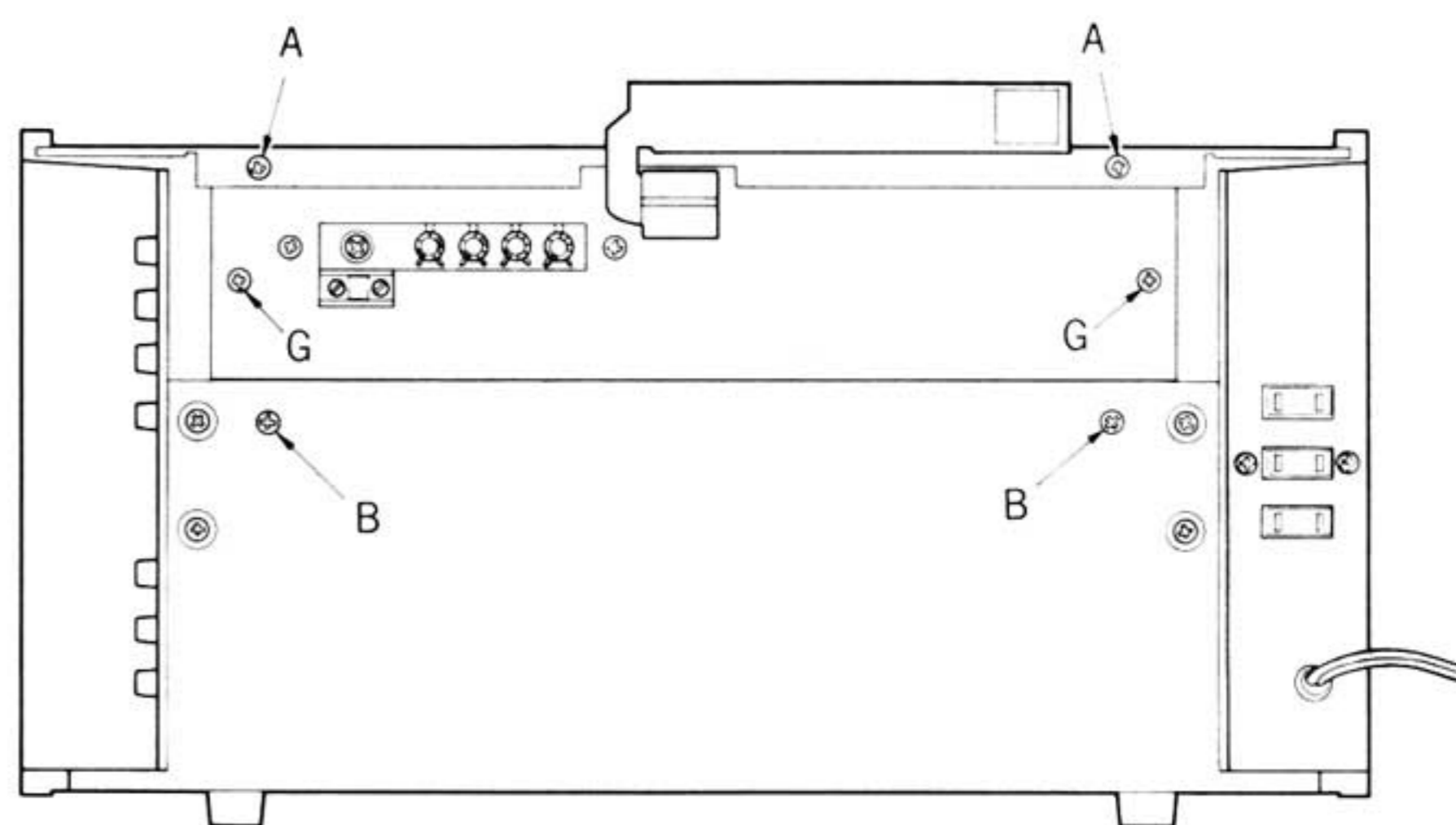

Fig. 1

### 2. Removal of Front Panel

- 1) Take out the two upper panel fixing screws indicated as C in Fig. 2.
- 2) Take out the two lower panel fixing screws indicated as D in Fig. 4.
- 3) Remove the knobs on the front panel. The tuning knob, (T in Fig. 3), should be removed by means of a hexagonal screw driver having a 2 mm opposite side.) The remaining knobs should be removed by forcefully pulling them out toward the front.
- 4) In this condition, the front panel can be removed toward the front.

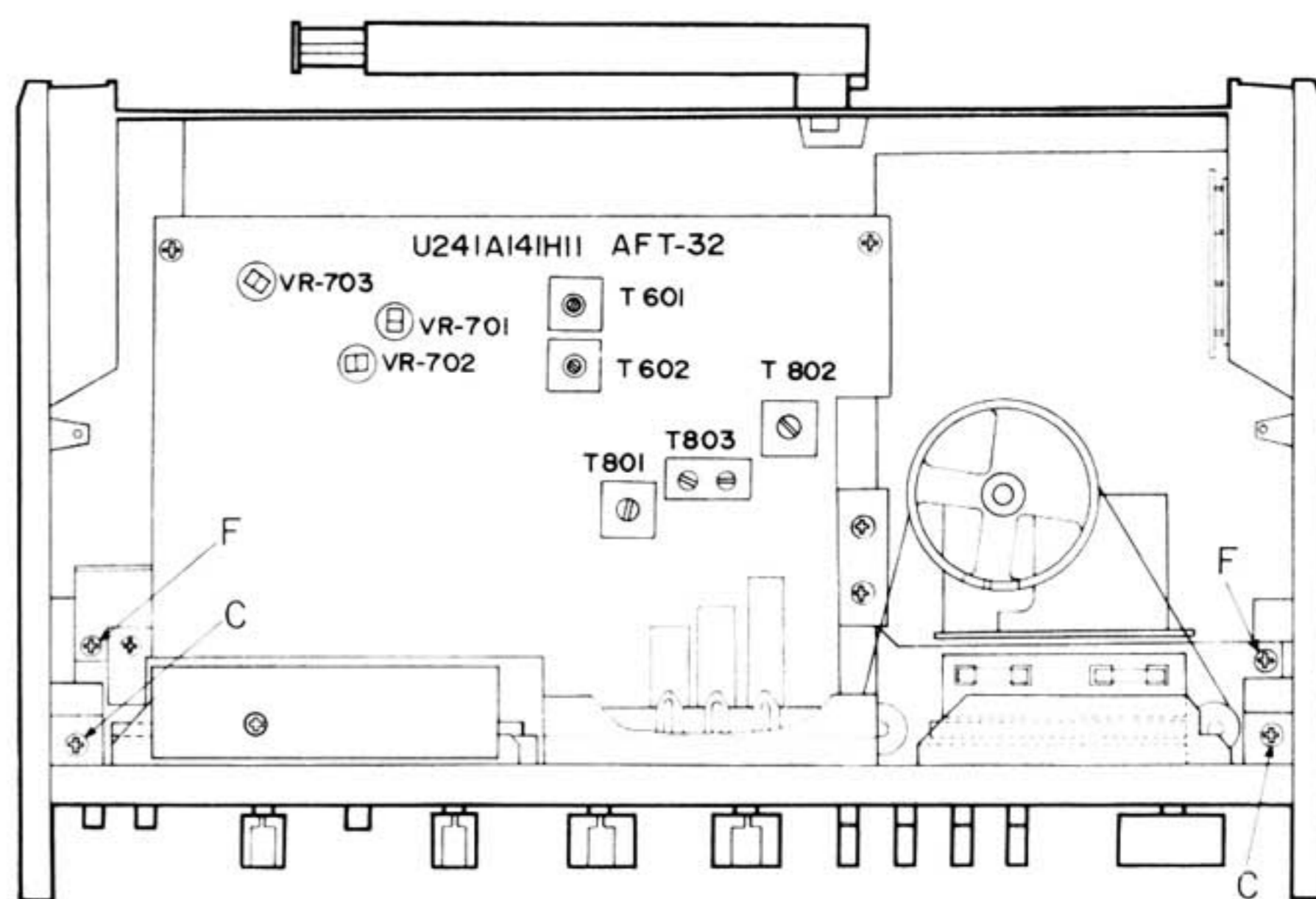

Fig. 2

### 3. Removal of Tuner Section

- 1) Disassemble the aluminum inlay of the tuner section by removing the four screws indicated as E in Fig. 5.
- 2) Take off the two chassis-fixing screws (F in Fig. 2) of the tuner section.
- 3) Remove the rear-chassis-fixing screws (9 of Fig. 1) of the tuner section.
- 4) Take off the two chassis-fixing screws (H and I in Fig. 4) of the tuner section.
- 5) Lift up the tuner section. To prevent short-circuiting between the tuner section's chassis and the preamplifier's printed circuit board, insert a cloth or the like in between as shown in Fig. 6.
- 6) With the set in this condition, the front end can be serviced or adjusted.
- 7) To remove the printed circuit board from the chassis when replacing the parts on it, the following screws must be removed.
  - (1) Take off the two holder setscrews for meter mounting (J in Fig. 6).
  - (2) Unscrew the two push switch assembly screws (K in Fig. 6).
  - (3) Unscrew the two printed circuit board assembly screws (L in Fig. 6).

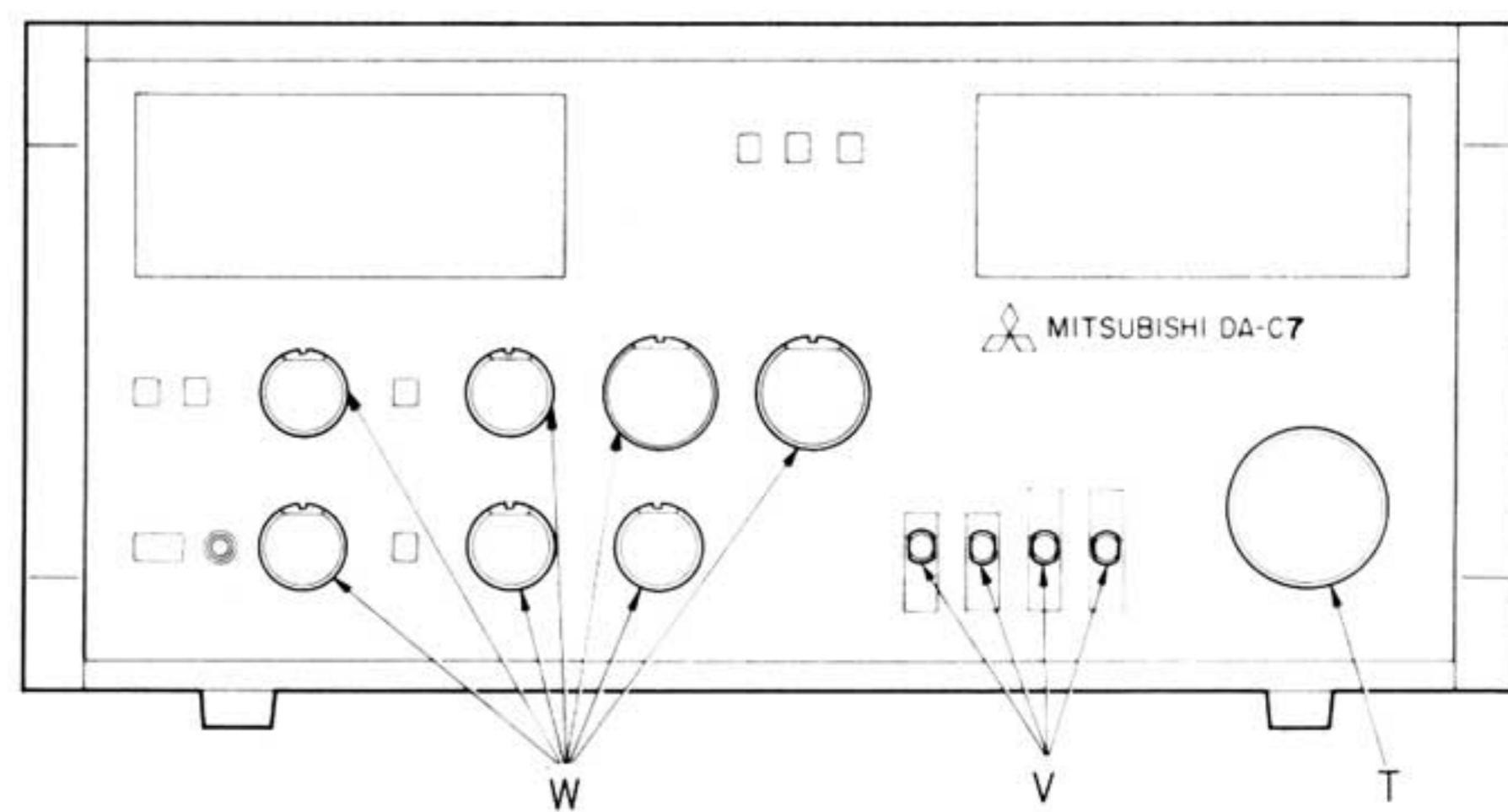

Fig. 3

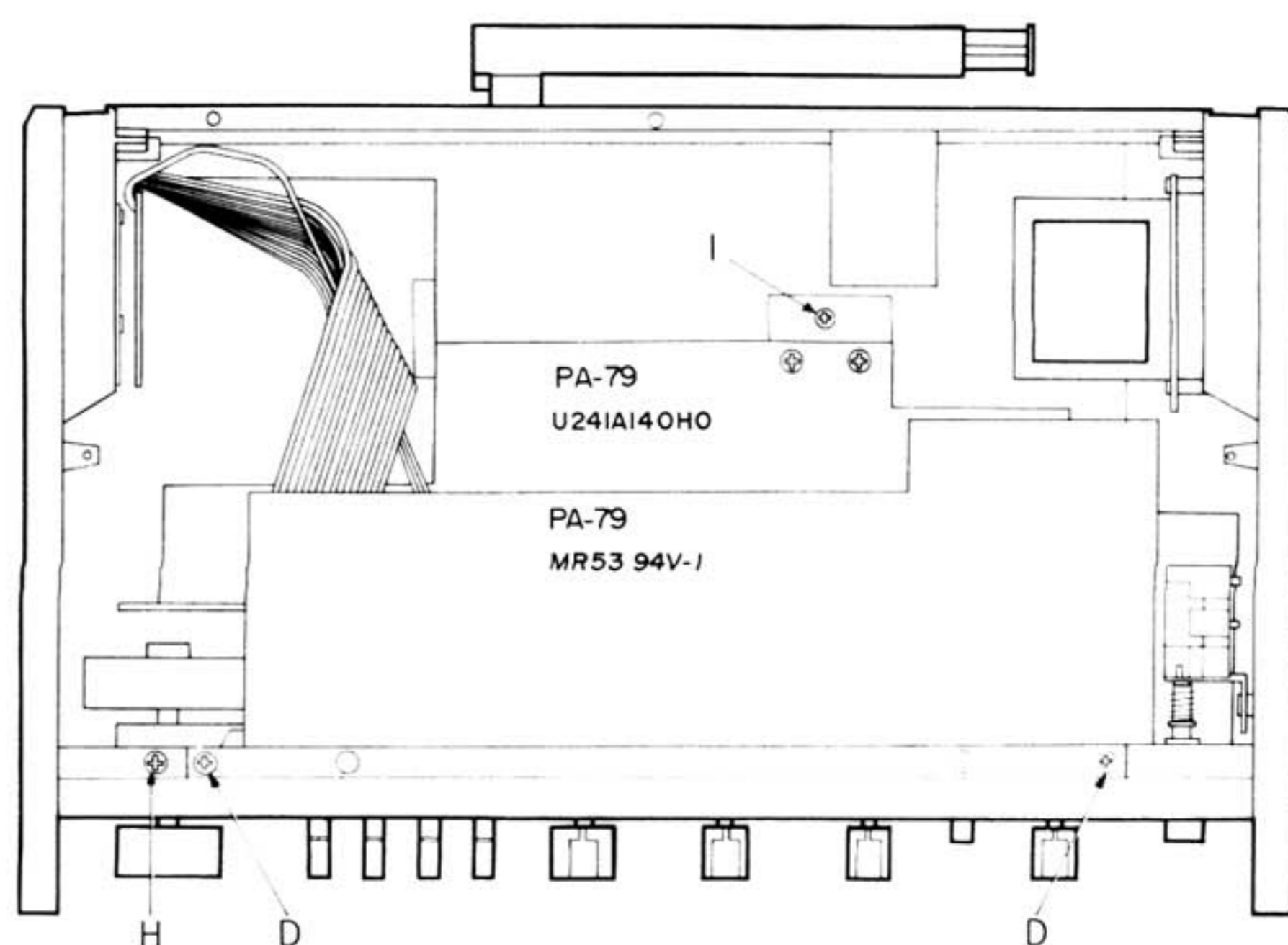

Fig. 4



## ■ FM SECTION

### 1. Front End Adjustment

- 1) With the signals of a signal generator (SG) connected to the FM-ANT terminal, take out the set's output from terminal 2 of IC701.
- 2) With the SG's frequency set to 87 MHz, turn the dial fully counterclockwise so that the tuner may indicate the lowest frequency. Adjust the local oscillator coil so as to make the signals generated by the SG maximum.
- 3) With the SG's frequency set to 109 MHz, turn the dial fully clockwise so that the tuner indicator may show the maximum frequency. Adjust the local oscillator trimmer C517 in a manner as to make the SG's signal maximum.
- 4) Repeat Steps 2) and 3) several times.
- 5) With the SG's frequency set to 88 MHz, set the tuner to indicate 88 MHz with the dial. Adjust coils L501 and L502 so as to make the output maximum.
- 6) With the SG's frequency set to 108 MHz, set the tuner to indicate 108 MHz with the dial. Adjust trimmers C502 and C506 so as to make the output maximum.

### 2. Adjustment of FM-MONO

- 1) Set the SG to 98 MHz, 400 Hz MONO modulation and the output to 80 dB.
- 2) Set the selector switch of the set to the FM position and the mode to FM-MONO/MUTING OFF and SELECTIVITY-WIDE.
- 3) Adjust the secondary side core (upper side) of T602 so that the center meter may indicate the center during detuning (approximately 100 MHz).
- 4) Tune the set to the SG's frequency (98 MHz). Tuning, in this case, is attained when the center meter is a state in which it indicates the center.  
Next, with the mode switch set to FM-AUTO/MUTING-ON, adjust VR703 so as to make the center meter indicate the center.
- 5) After connecting a distortion meter to the output pin terminal, adjust the primary side core (lower side) of T601 so as to make the distortion factor minimum. In this case, if the center meter does not indicate the center, adjust the secondary side of T602 again until it does.

### 3. Adjustment of FM-MPX

- 1) Set the SG to 98 MHz, 1 kHz STEREO to L+R 90%, pilot to 10% modulation and the output to 80 dB.
- 2) Set the selector switch of the set to the FM position and mode to FM-MONO/MUTING-OFF and to SELECTIVITY-WIDE.  
While receiving 98 MHz signals from the SG, adjust the local oscillation trimmer C517 of the front end in a manner to make the indicator indicate 98 MHz on the dial plate.
- 3) Place the set to FM-AUTO/MUTING-ON. Shift the position of the indicator to the left and right from 98 MHz and confirm that LOCK and MUTING operations are normal.
- 4) Set the SG modulation to OFF. Connect the frequency counter to the terminal 14 of IC701. Adjust VR701 for the frequency counter to read  $76K \pm 0.2KHz$ .
- 5) Connect the stereo modulator to SG to turn on the pilot signal. Then check to see that the stereo indicator is light up.
- 6) Adjust VR702 so that the leakage to the output of the pilot signal of 19KHz may be minimized.
- 7) With the modulation of the stereo modulator set to either L or R, adjust VR703 so that the leakage to L → R and that to R → L may be minimized.

## ■ AM SECTION

### 1. Tracking Adjustment

- 1) With the SG's signal set to 600 kHz and 400 Hz to 30% modulation, and the indicator of the set tuned to 600 kHz, adjust the COIL-ANT (L801) and COIL-OSC (T801) so that the output will become maximum.
- 2) With the SG's signal set to 1,400 kHz and the indicator of the set tuned to 1,400 kHz, adjust the antenna trimmer C525 and local oscillation trimmer C523 to make the output maximum.
- 3) Repeat steps 1) and 2) several times.

# EQUIVALENT CIRCUIT DIAGRAM

HA-11223

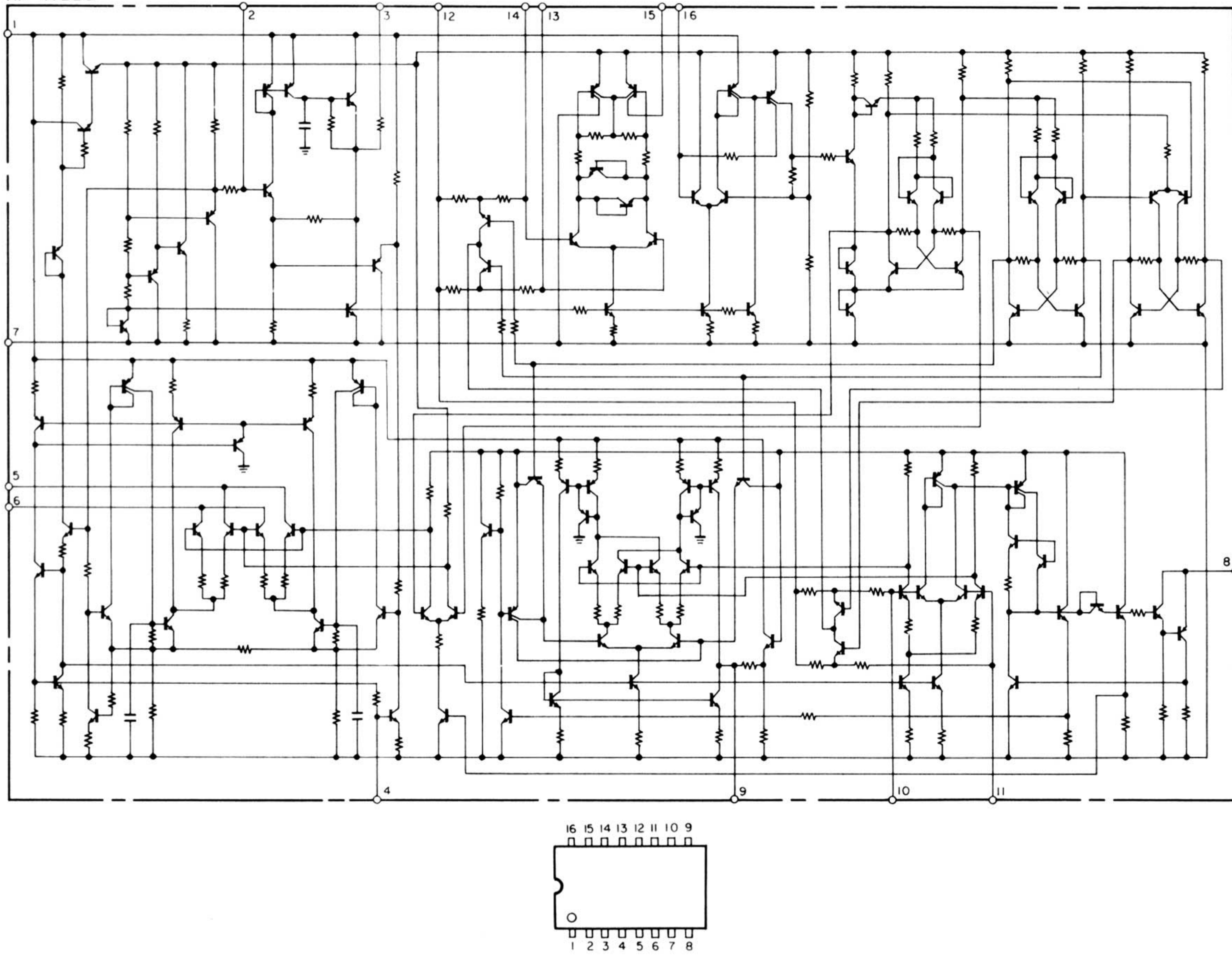

HA-1197

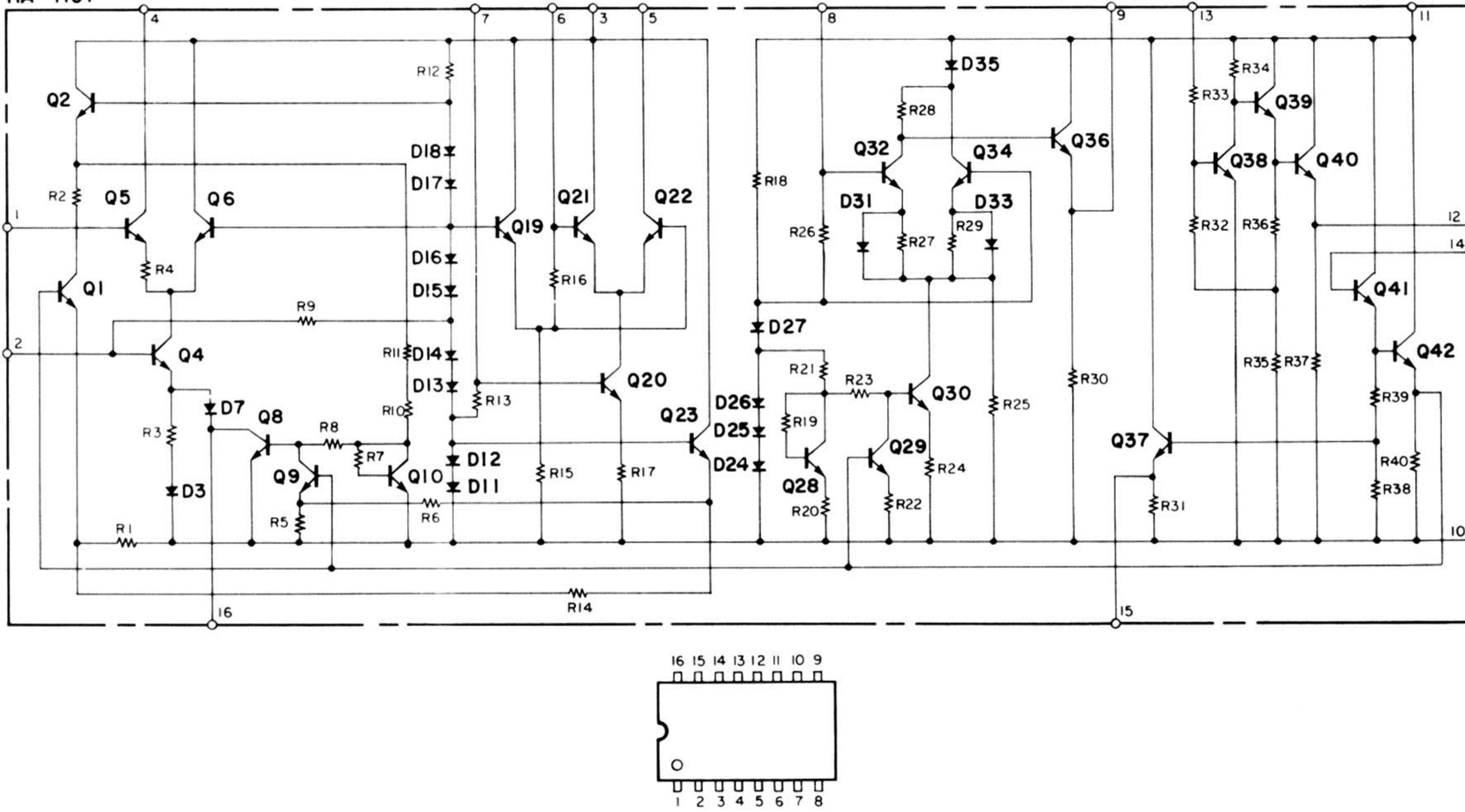

KB-4420

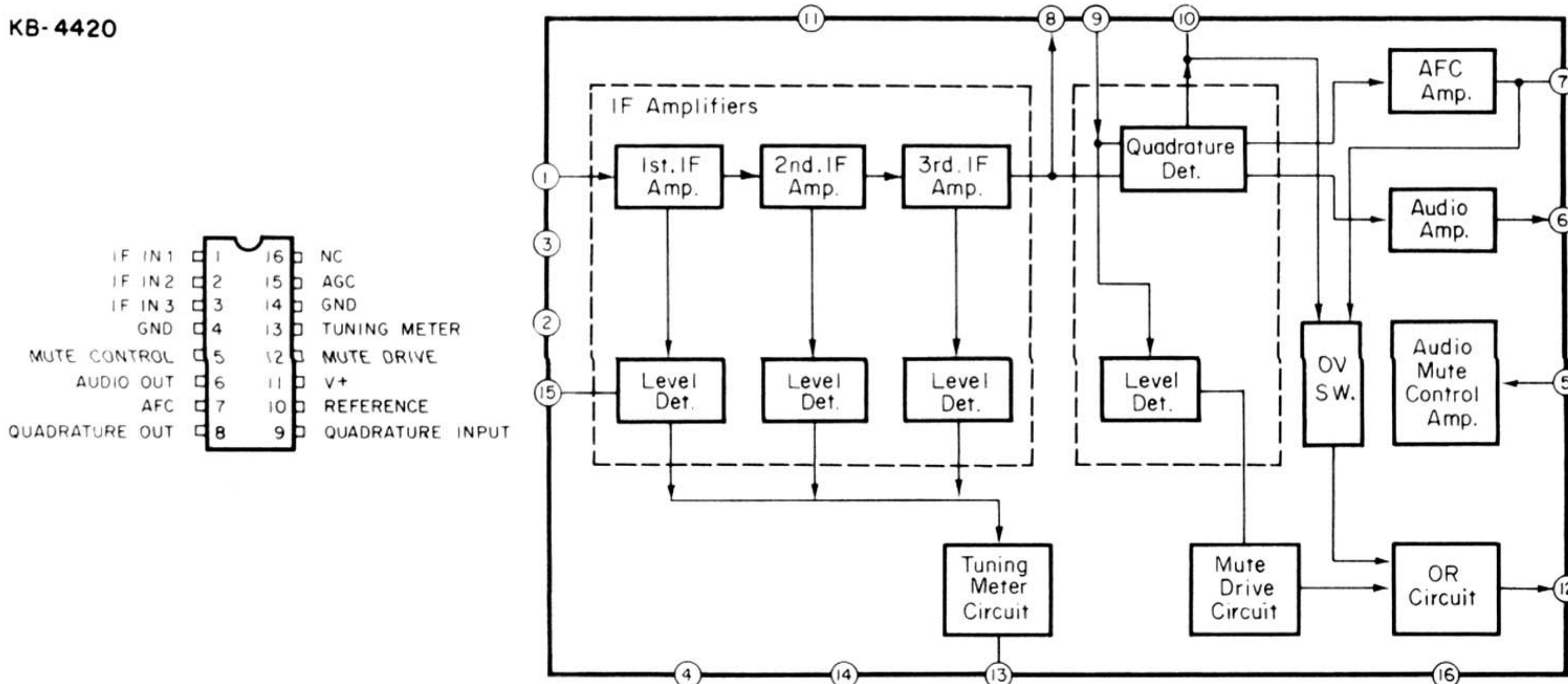

M5213L

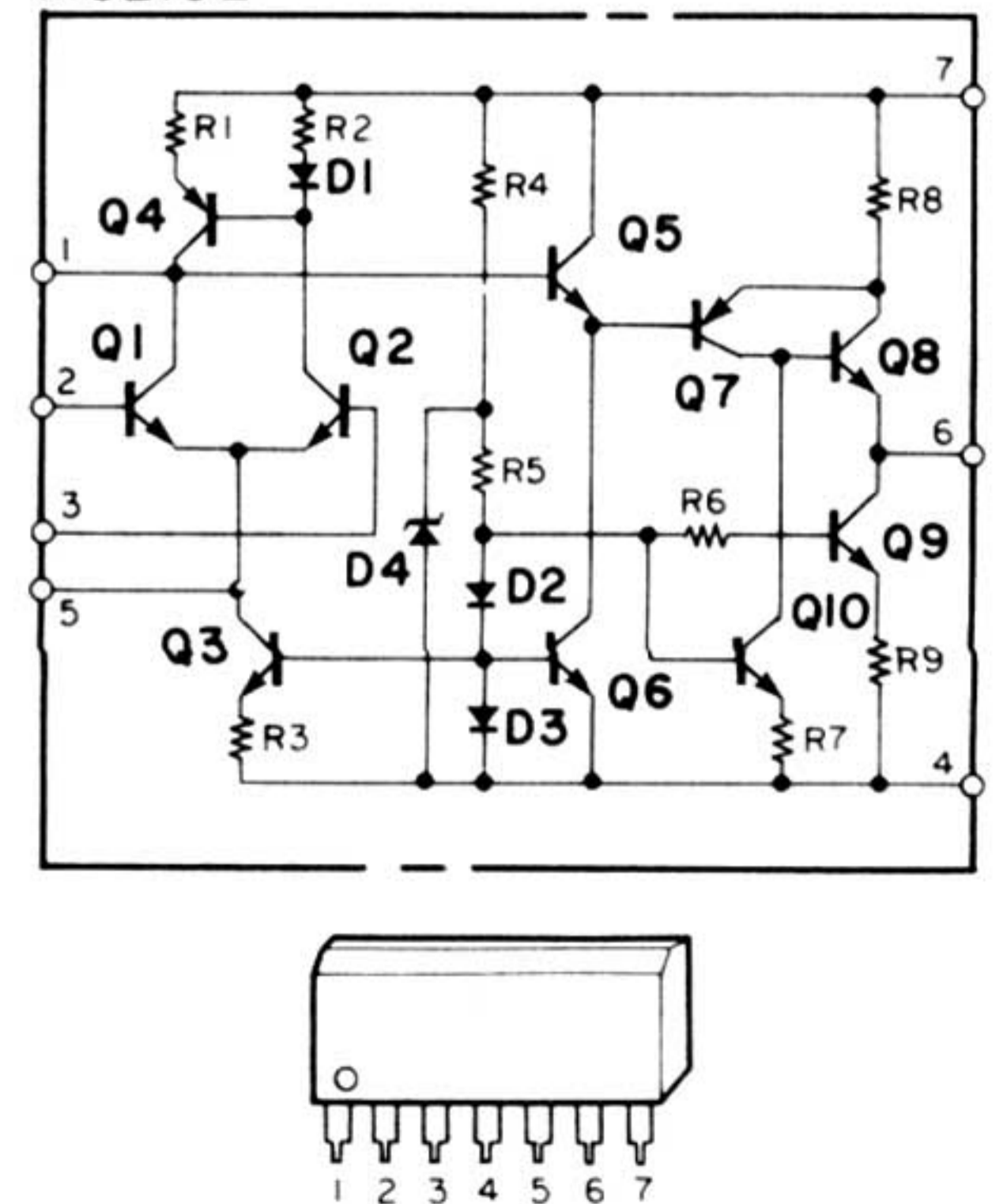

- ① Phase compensation terminal
- ② Input terminal
- ③ Feedback terminal
- ④ Minus power terminal
- ⑤ Buzz preventive terminal
- ⑥ Output terminal
- ⑦ Plus power terminal

SCHEMATIC DIAGRAM

■ TUNER SECTION



■PREAMPRIFIER SECTION



EXTERNAL VIEW AND POLARITY DIAGRAM OF THE TRANSISTOR.

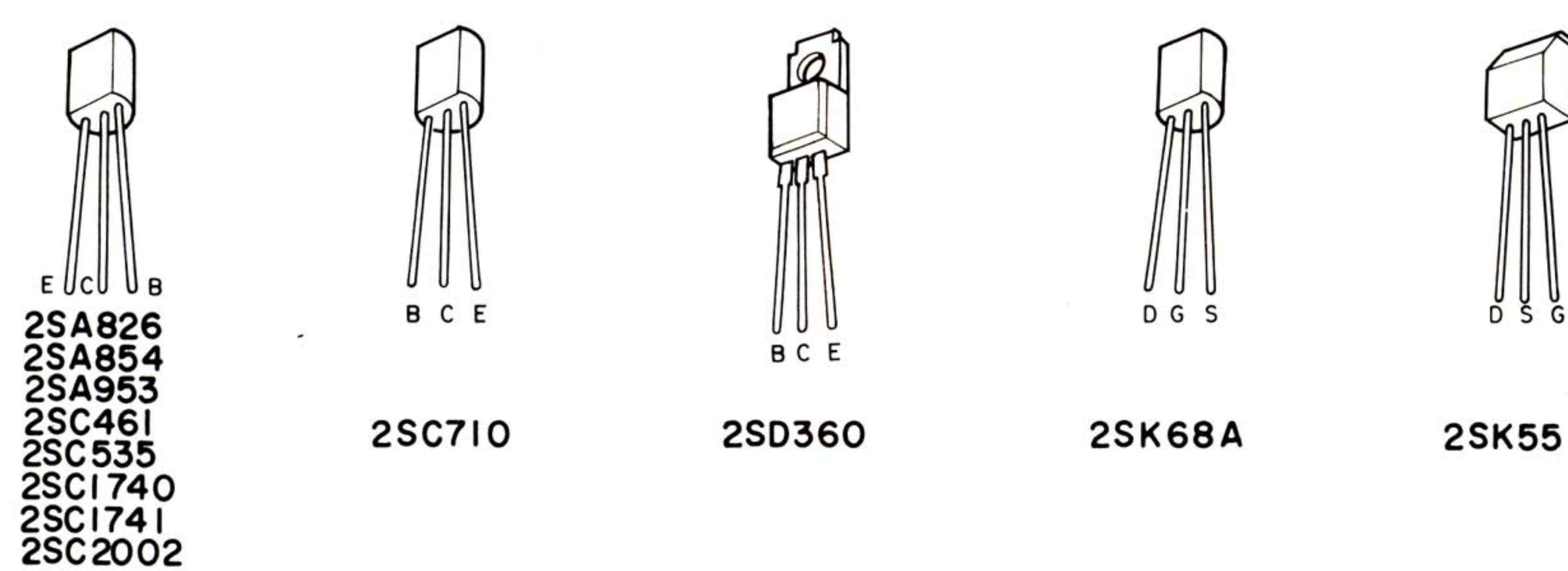

NOTE : 1. SW 1 AM/FM Switch ..... FM Position  
 SW 2 AUTO Muting/MONO ..... AUTO Position  
 SW 3 WIDE/NARROW ..... WIDE Position  
 S 1 SELECTOR Switch ..... Phono 1 Position  
 S 2 DUPLICATE Switch ..... Source Position  
 S 3 TAPE MONITOR Switch ..... Source Position  
 S 4 MODE Switch ..... Stereo Position  
 S 5 SUBSONIC FILTER Switch ..... off Position  
 S 6 TONE Switch ..... on Position  
 S 7 TONE Switch ..... on Position  
 S8-1 SPEAKERS Switch ..... off Position  
 S8-2 SPEAKERS Switch ..... off Position

2. Unit of C and R  
 (1) C ..... non-symbol  $\mu$ F  
 p symbol pF  
 (2) R ..... non-symbol  $\Omega$   
 K symbol K $\Omega$

3. The voltage in each section is the value measured by the DC20K $\Omega$ /V tester  
 This circuit is a basic circuit diagram and is subject to change without notice for improvements.

PA-79

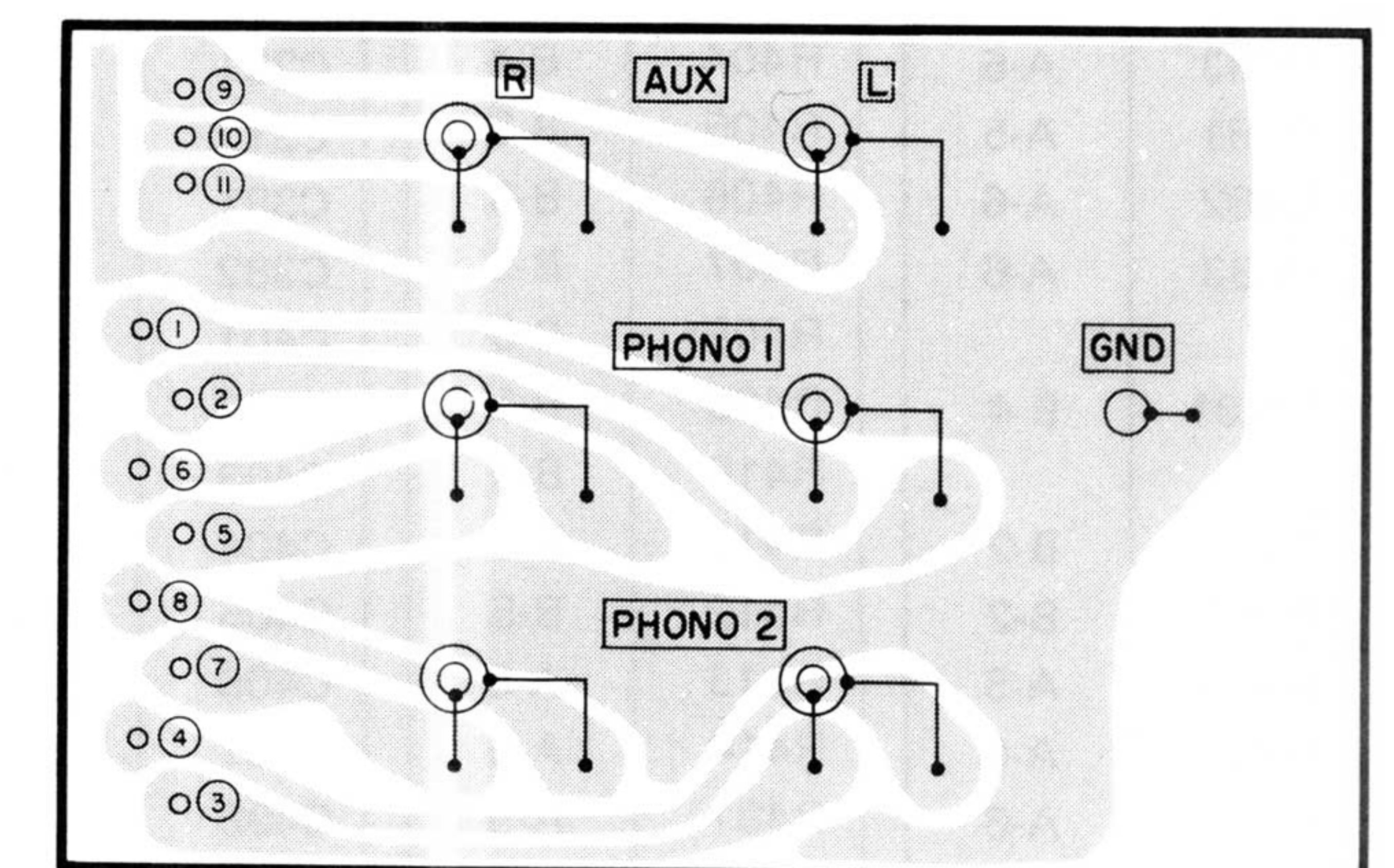
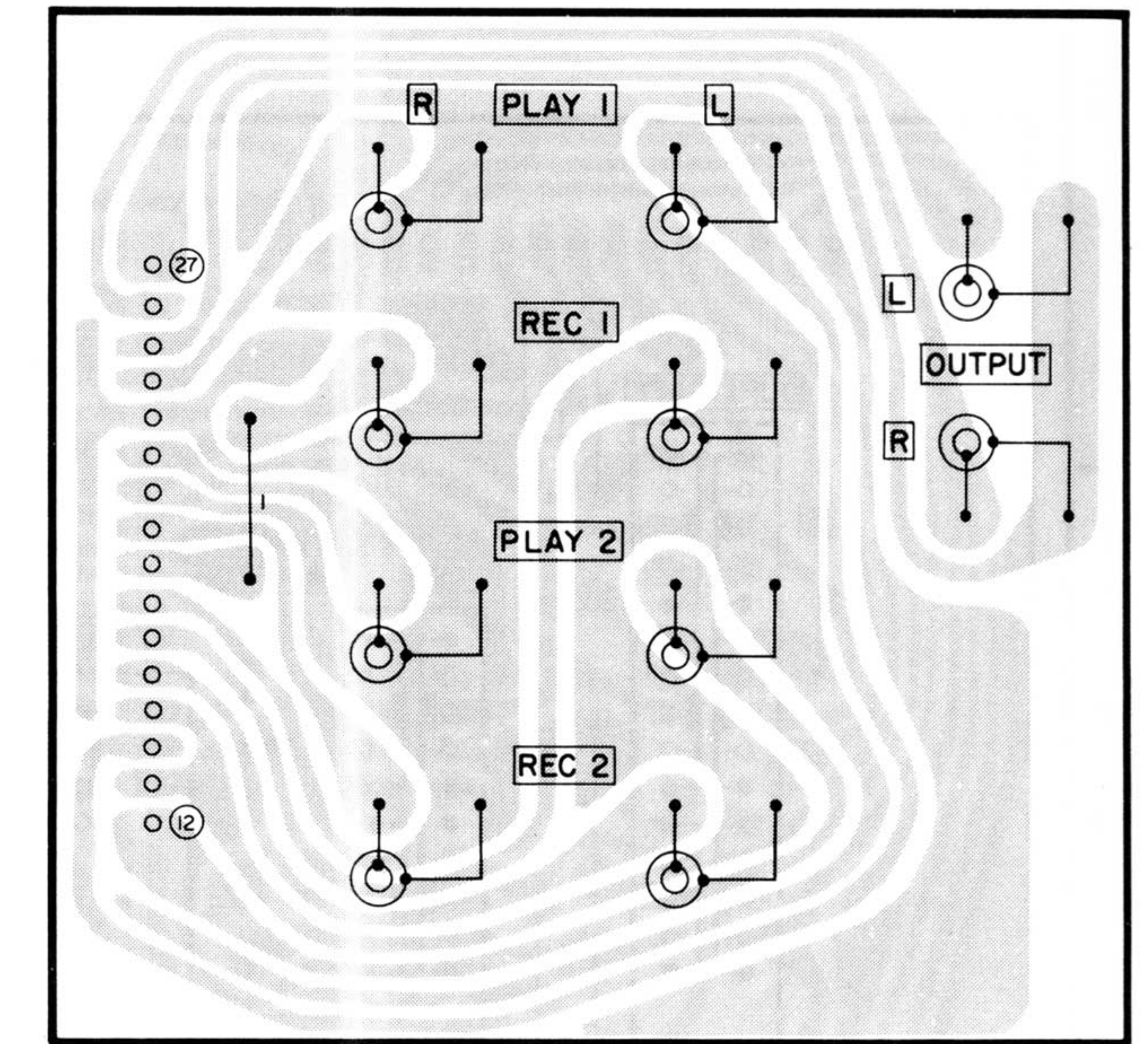
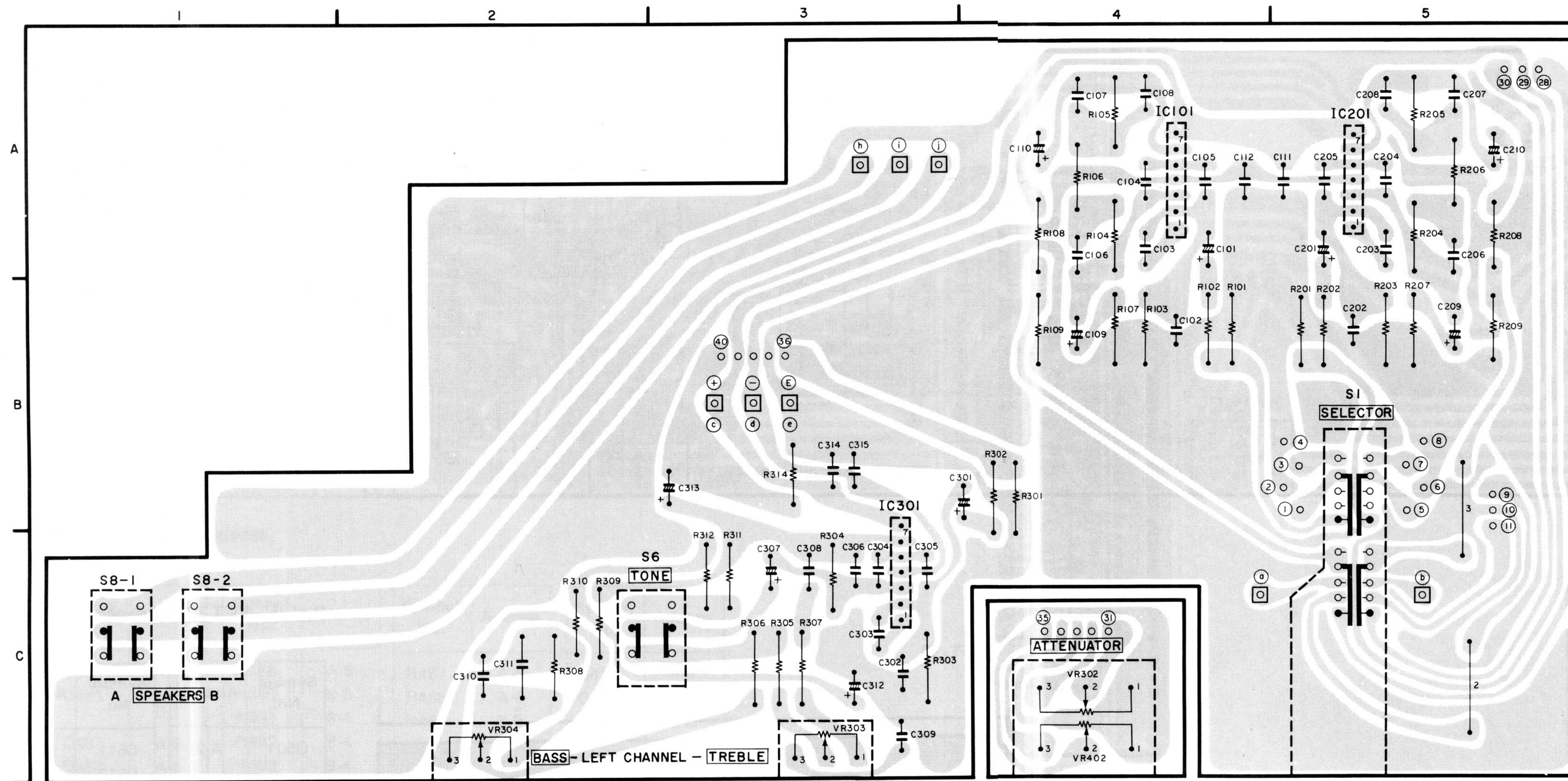

P.C.B PA-79 Address

Symbol No.	Address	Symbol No.	Address	Symbol No.	Address	Symbol No.	Address
IC101	A-4	R203	B-5	R309	C-2	C110	A-4
IC201	A-5	R204	A-5	R310	C-2	C111	A-5
IC301	C-3	R205	A-5	R311	C-3	C112	A-4
		R206	A-5	R312	C-3	C201	A-5
R101	B-4	R207	B-5	R314	B-3	C202	B-5
R102	B-4	R208	A-5			C203	A-5
R103	B-4	R209	B-5	C101	A-4	C204	A-5
R104	A-4	R301	B-4	C102	B-4	C205	A-5
R105	A-4	R302	B-4	C103	A-4	C206	A-5
R106	A-4	R303	C-3	C104	A-4	C207	A-5
R107	B-4	R304	C-3	C105	A-4	C208	A-5
R108	A-4	R305	C-3	C106	A-4	C209	B-5
R109	B-4	R306	C-3	C107	A-4	C210	A-5
R201	B-5	R307	C-3	C108	A-4	C301	B-4
R202	B-5	R308	C-2	C109	B-4	C302	C-3



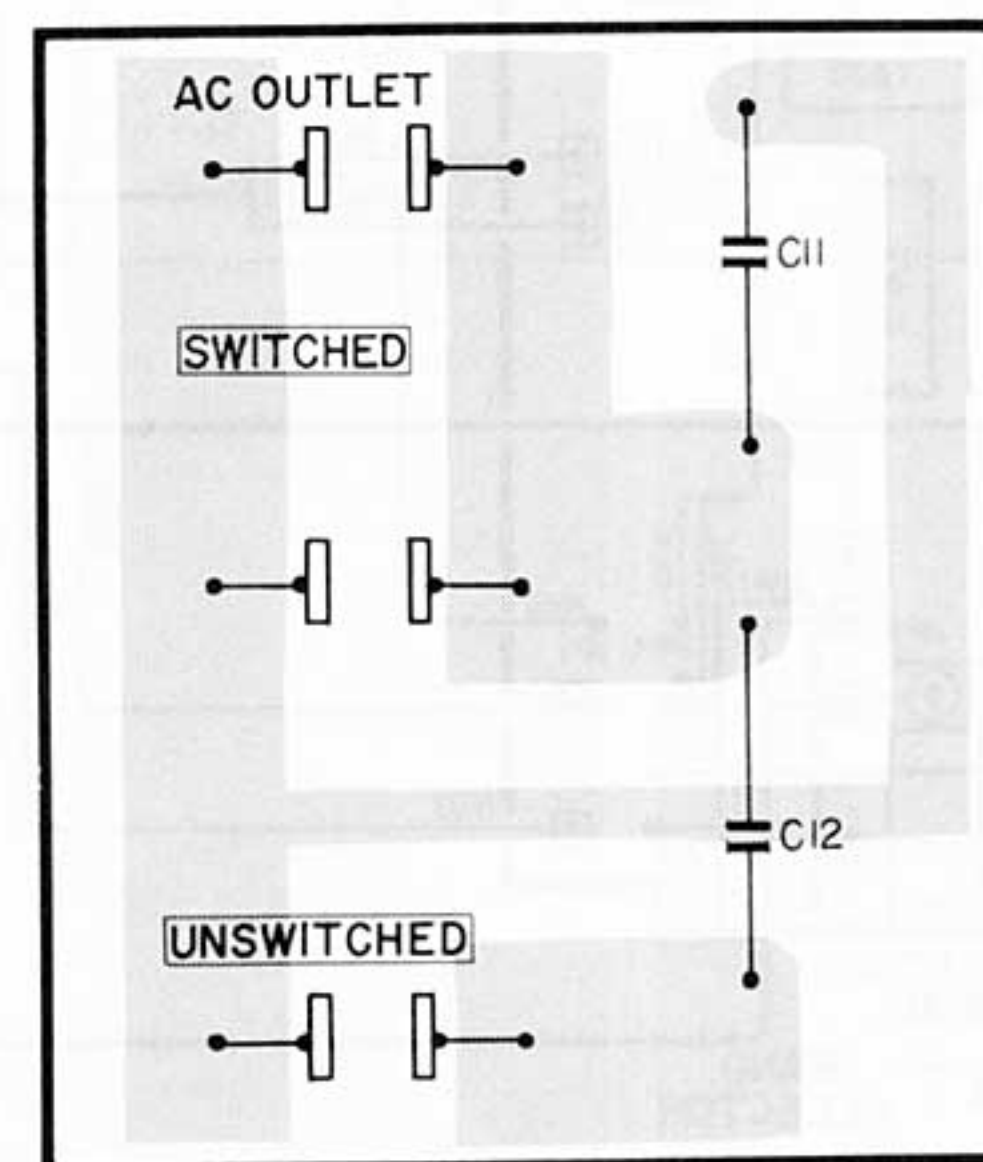
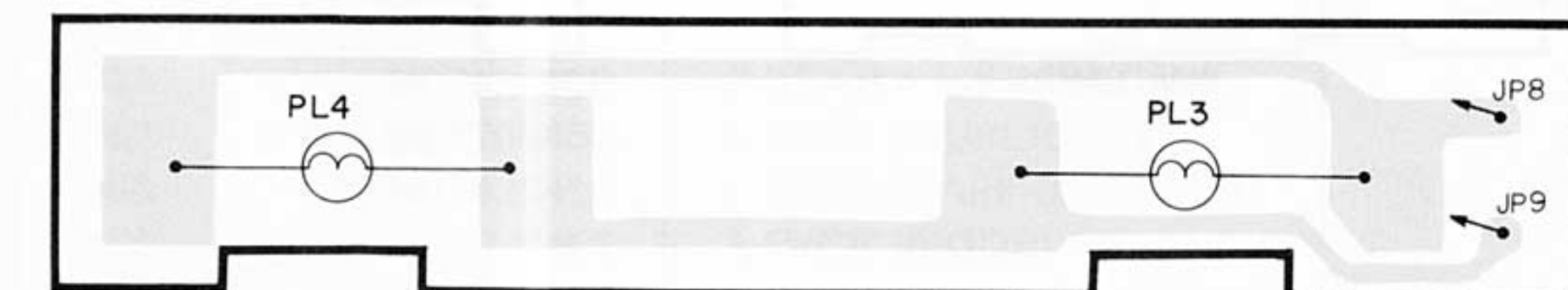
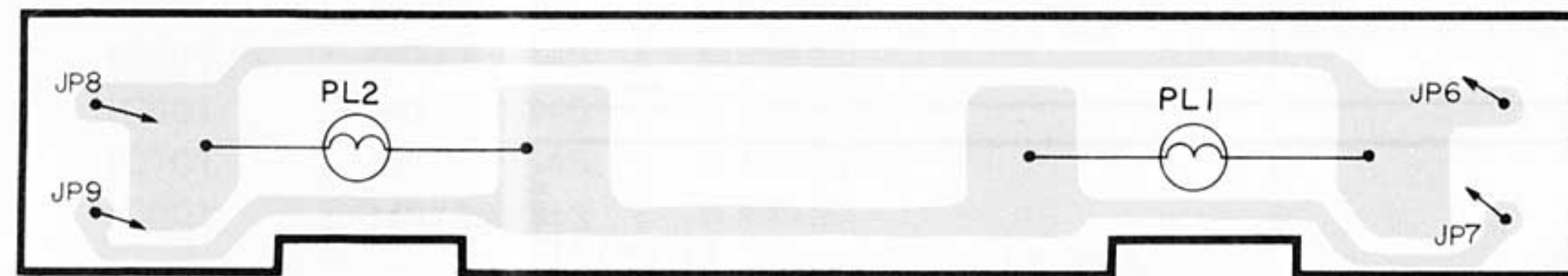
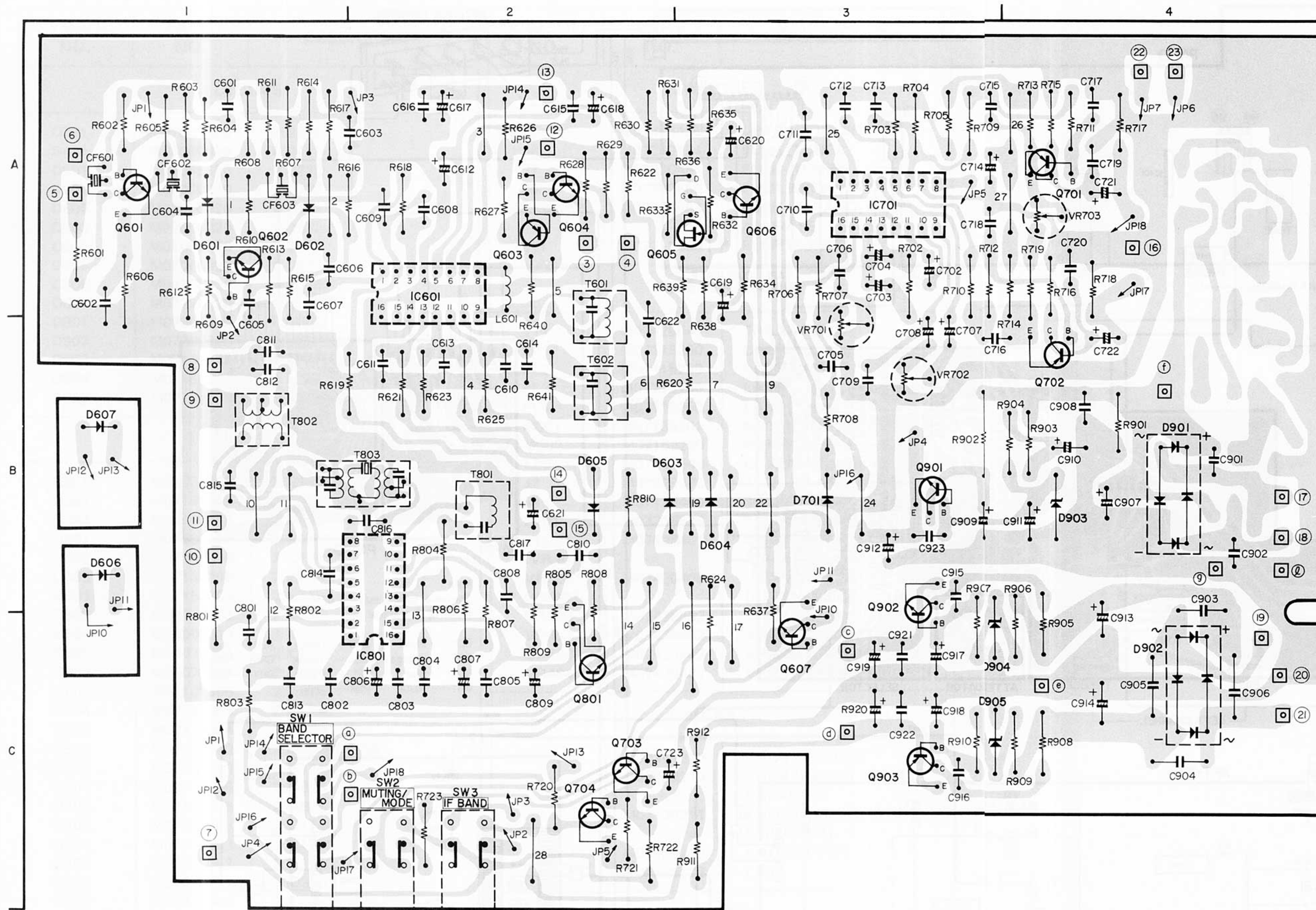

P.C.B AFT-32 Address

Symbol No.	Address	Symbol No.	Address	Symbol No.	Address	Symbol No.	Address
D601	A-1	R623	B-2	R907	C-3	C806	C-2
D602	A-1	R624	C-3	R908	C-4	C807	C-2
D603	B-2	R625	B-2	R909	C-4	C808	B-2
D604	B-3	R626	A-2	R910	C-3	C809	C-2
D605	B-2	R627	A-2	R911	C-3	C810	B-2
D606	B-1	R628	A-2	R912	C-3	C811	B-1
D607	B-1	R629	A-2			C812	B-1
D701	B-3	R630	A-2	C601	A-1	C813	C-1
D901	B-4	R631	A-2	C602	A-1	C814	B-1
D902	C-4	R632	A-3	C603	A-2	C815	B-1
D903	B-4	R633	A-2	C604	A-1	C816	B-2
D904	C-3	R634	A-3	C605	A-1	C817	B-2
D905	C-3	R635	A-3	C606	A-1	C901	B-4
		R636	A-3	C607	A-1	C902	B-4
Q601	A-1	R637	B-3	C608	A-2	C903	B-4
Q602	A-1	R638	A-3	C609	A-2	C904	C-4
Q603	A-2	R639	A-3	C610	B-2	C905	C-4
Q604	A-2	R640	A-2	C611	B-2	C906	C-4
Q605	A-3	R641	B-2	C612	A-2	C907	B-4
Q606	A-3	R702	A-3	C613	B-2	C908	B-4
Q607	C-3	R703	A-3	C614	B-2	C909	B-3
Q701	A-4	R704	A-3	C615	A-2	C910	B-4
Q702	B-4	R705	A-3	C616	A-2	C911	B-4
Q703	C-2	R706	A-3	C617	A-2	C912	B-3
Q704	C-2	R707	A-3	C618	A-2	C913	C-4
Q801	C-2	R708	B-3	C619	A-3	C914	C-4
Q901	B-3	R709	A-3	C620	A-3	C915	B-3
Q902	B-3	R710	A-3	C621	B-2	C916	C-3
Q903	C-3	R711	A-4	C622	B-2	C917	C-3
		R712	A-3	C702	A-3	C918	C-3
IC601	A-2	R713	A-4	C703	A-3	C919	C-3
IC701	A-3	R714	A-4	C704	A-3	C920	C-3
IC801	B-2	R715	A-4	C705	B-3	C921	C-3
		R716	A-4	C706	A-3	C922	C-3
R601	A-1	R717	A-4	C707	B-3	C923	B-3
R602	A-1	R718	A-4	C708	B-3		
R603	A-1	R719	A-4	C709	B-3	VR701	B-3
R604	A-1	R720	C-2	C710	A-3	VR702	B-3
R605	A-1	R721	C-2	C711	A-3	VR703	A-4
R606	A-1	R722	C-2	C712	A-3		
R607	A-1	R801	C-1	C713	A-3	T601	A-2
R608	A-1	R802	C-1	C714	A-3	T602	B-2
R609	A-1	R803	C-1	C715	A-3	T801	B-2
R610	A-1	R804	B-2	C716	B-3	T802	B-1
R611	A-1	B805	B-2	C717	A-4	T803	B-2
R612	A-1	R806	B-2	C718	A-3		
R613	A-1	R807	C-2	C719	A-4	CF601	A-1
R614	A-1	R808	B-2	C720	A-4	CF602	A-1
R615	A-1	R809	C-2	C721	A-4	CF603	A-1
R616	A-2	R810	B-2	C722	B-4		
R617	A-1	R901	B-4	C723	C-2	SW1	C-2
R618	A-2	R902	B-3	C801	C-1	SW2	C-2
R619	B-2	R903	B-4	C802	C-1	SW3	C-2
R620	B-3	R904	B-4	C803	C-2		
R621	B-2	R905	C-4	C804	C-2	L601	A-2
R622	A-2	R906	C-4	C805	C-2		

WIRING

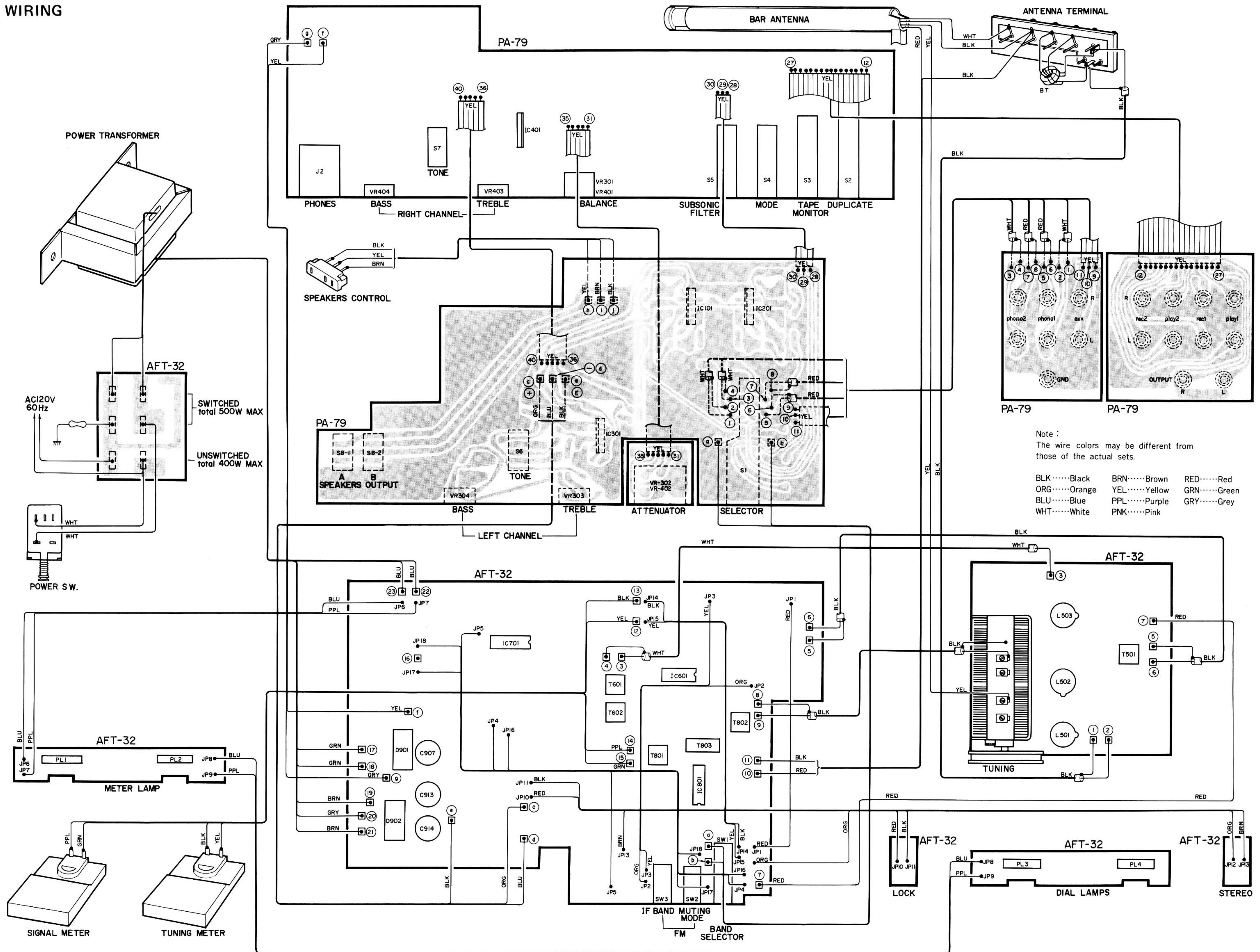

# PARTS LIST

SYMBOL NO.	PART NO.	DESCRIPTION
<b>DIODES</b>		
D381	M07060320	1S2473
D481	M07060320	1S2473
D501	M07085320	1S2236
D601	M07060320	1S2473
D602	M07060320	1S2473
D603	M07060320	1S2473
D604	M07060320	1S2473
D605	M07060320	1S2473
D606	M07228320	SEL105R
D607	M07228320	SEL105R
D901	M07300323	ESAB03
D902	M07300323	ESAB03
D903	M07141322	MZ314
D904	M07140320	MZ320
D905	M07140320	MZ320
<b>TRANSISTORS</b>		
Q381	M07387303	2SC1740
Q382	M07141303	2SC1741
Q383	M07137308	2SA854
Q481	M07387303	2SC1740
Q482	M07141303	2SC1741
Q483	M07137308	2SA854
Q501	M07152303	2SK55
Q502	M04070303	2SC535
Q503	M04066313	2SC461
Q601	M04070304	2SC710
Q602	M04070304	2SC710
Q603	M07137306	2SA826
Q604	M07387303	2SC1740
Q605	M07139304	2SK68A
Q606	M07387303	2SC1740
Q607	M07387303	2SC1740
Q701	M07137306	2SA826
Q702	M07137306	2SA826
Q703	M07387303	2SC1740
Q704	M07387303	2SC1740
Q801	M07387303	2SC1740
Q901	M05079311	2SD360
Q902	M07229305	2SC2002
Q903	M07229303	2SA953
<b>ICs</b>		
IC101	M07388343	M5213L
IC201	M07388343	M5213L
IC301	M07388343	M5213L
IC401	M07388343	M5213L
IC601	M07361345	KB4420B
IC701	M07357345	HA11223W
IC801	M07387343	HA1197
<b>SWITCHES</b>		
S1	M07426452	ROTARY (SELECTOR)
S2	M07290452	LEVER (DUPLICATE)
S3	M07426450	LEVER (TAPE-MONITOR)
S4	M07426451	LEVER (MODE)

SYMBOL NO.	PART NO.	DESCRIPTION
<b>SWITCHES</b>		
S5	M07426451	LEVER (FILTER)
S6	M07290454	PUSH (TONE)
S7	M07290454	PUSH (TONE)
S8	M07290455	PUSH (SPEAKERS)
SW1~SW3	M07426453	PUSH (IF BAND, MODE AM-FM SELECTOR)
S11	M07213450	PUSH (POWER)
<b>ELECTRICAL</b>		
T11	M07426549	TRANS-POWER
PL1	M07115250	LAMP
PL2	M07115250	LAMP
PL3	M07115250	LAMP
PL4	M07115250	LAMP
M601	M07163261	METER (TUNING)
M602	M07163260	METER (SIGNAL)
L801	M07241540	COIL-ANTENNA
J2	M07229476	JACK (HEAD PHONE)
J3	M07139480	SOCKET
Z501	M07236575	TERMINAL BOARD
VR301	M07426401	VR-W-HB250K25
(VR401)		(BALANCE)
VR302	M07426400	VR-W-B250K25
(VR402)		(ATTENUATOR)
VR303	M07426402	VR-STD-C100K25 (TREBLE)
VR304	M07426402	VR-STD-C100K25 (BASS)
VR403	M07426402	VR-STD-C100K25 (TREBLE)
VR404	M07426402	VR-STD-C100K25 (BASS)
<b>CABINET</b>		
	M07141210 M07290210	KNOB (TUNING) KNOB (BASS, TREBLE, BALANCE)
	M07139211	KNOB (ATTENUATOR, SELECTOR)
	M07139213 M04108195	KNOB-LEVER LEG
<b>PACKING</b>		
	M07426900 M07426930 M07139910 M07426999 M07166998	PACKING BOX PACKING BAG CUSHION I.B WARRANTY CARD

# PACKAGE INSTRUCTION



I.B.:  
WARRANTY CARD:

CUSHION:

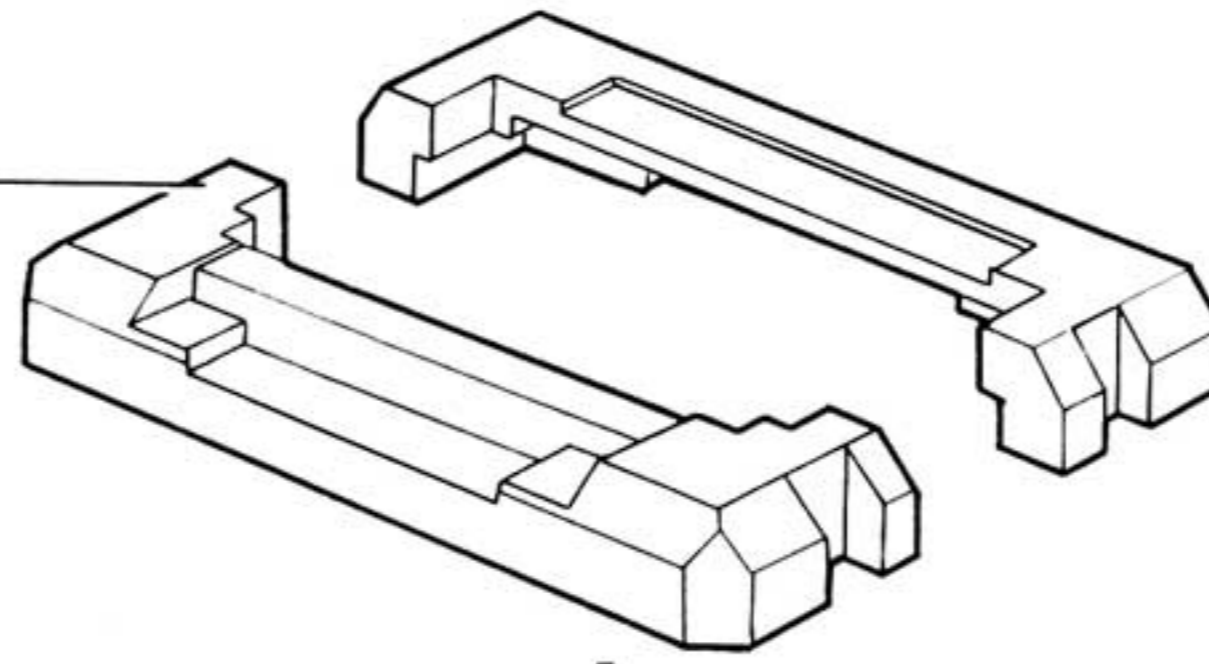

PACKING BAG:

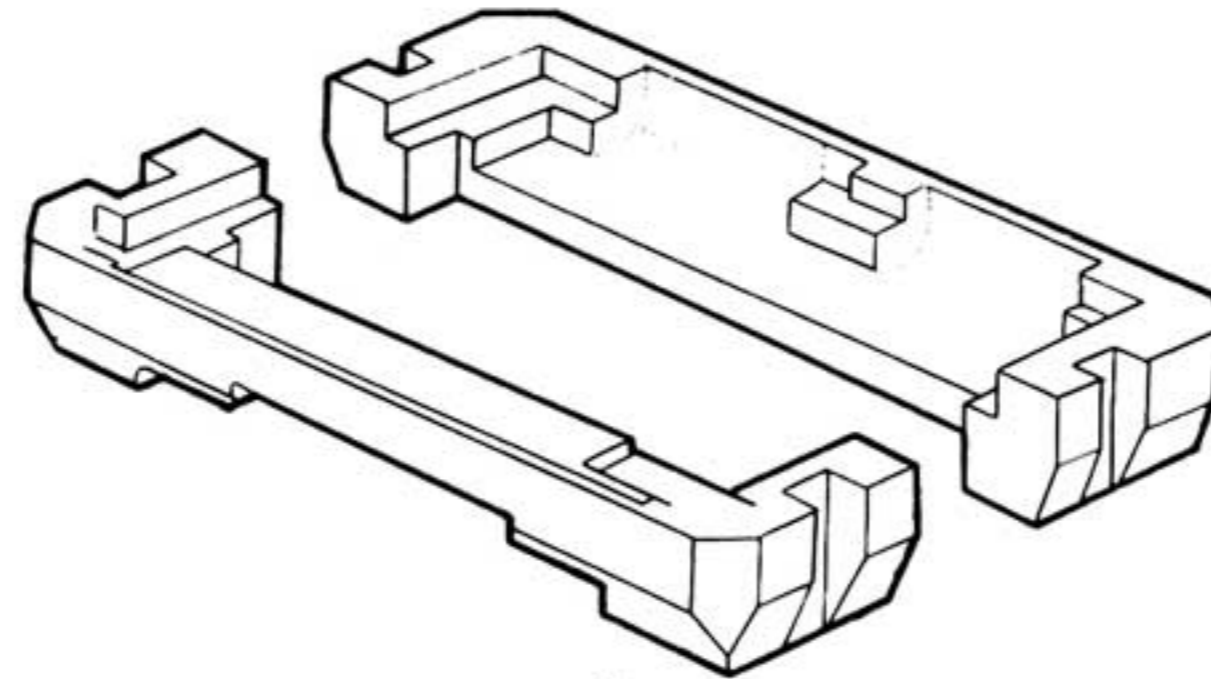
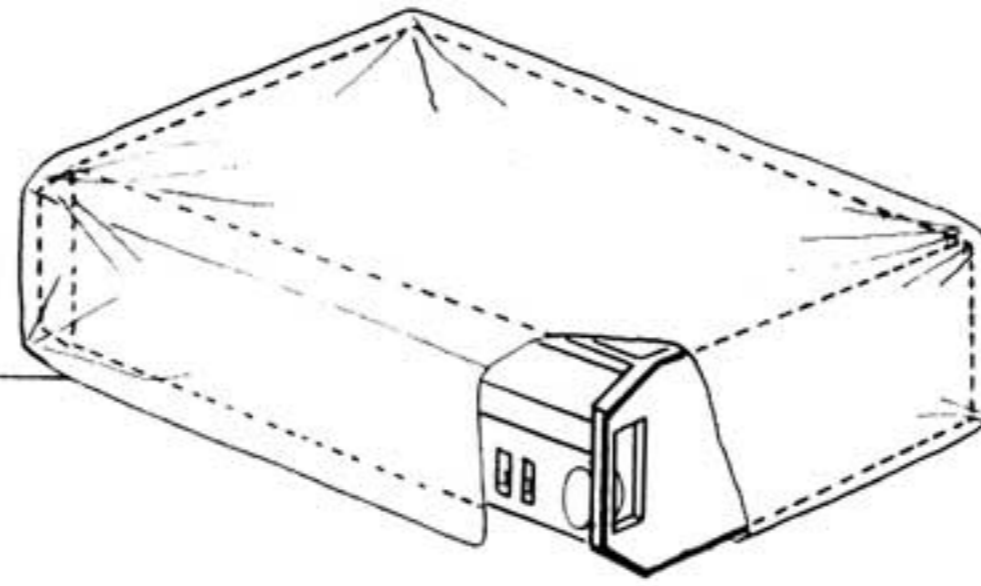

PACKING BOX:

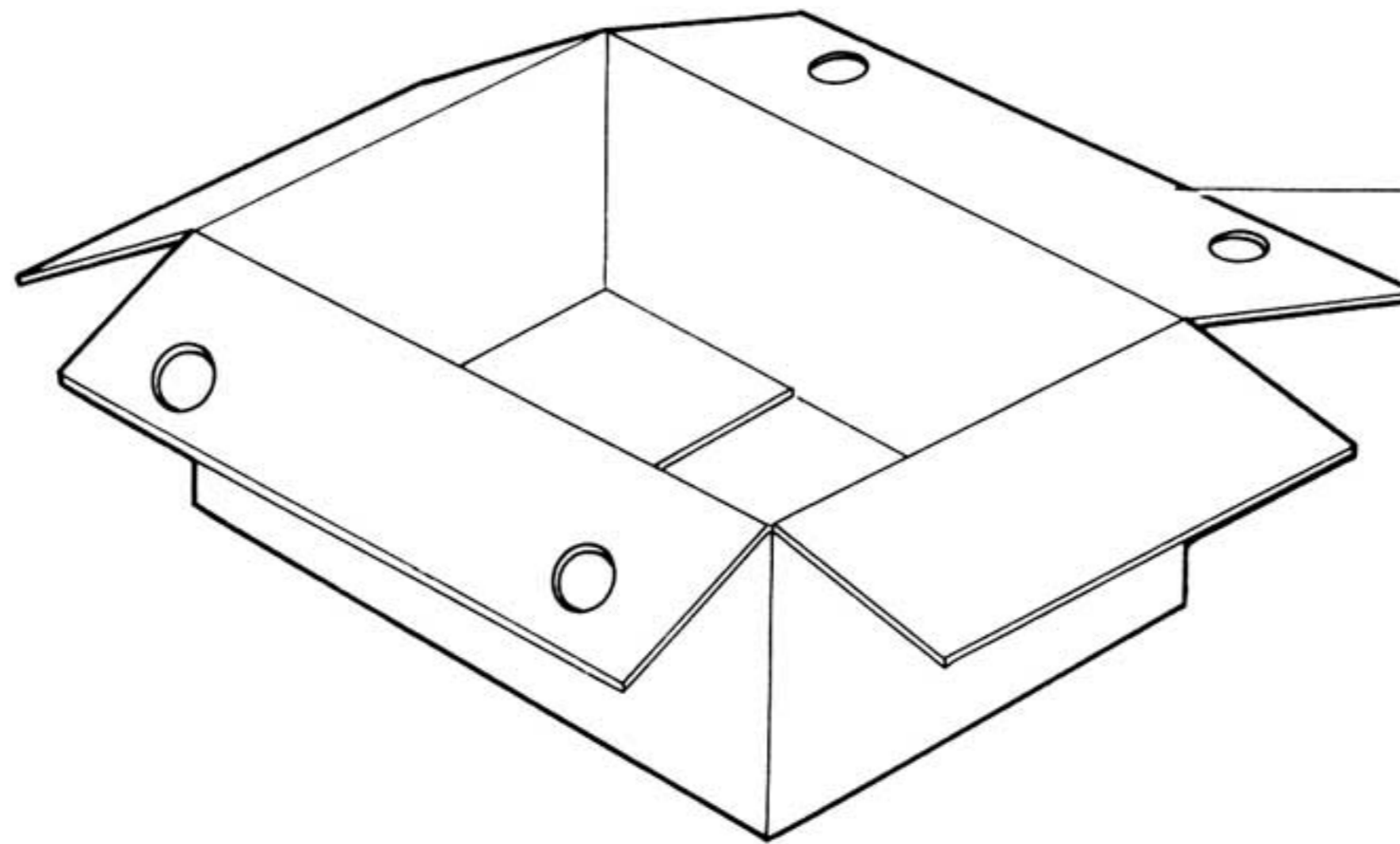

Staple

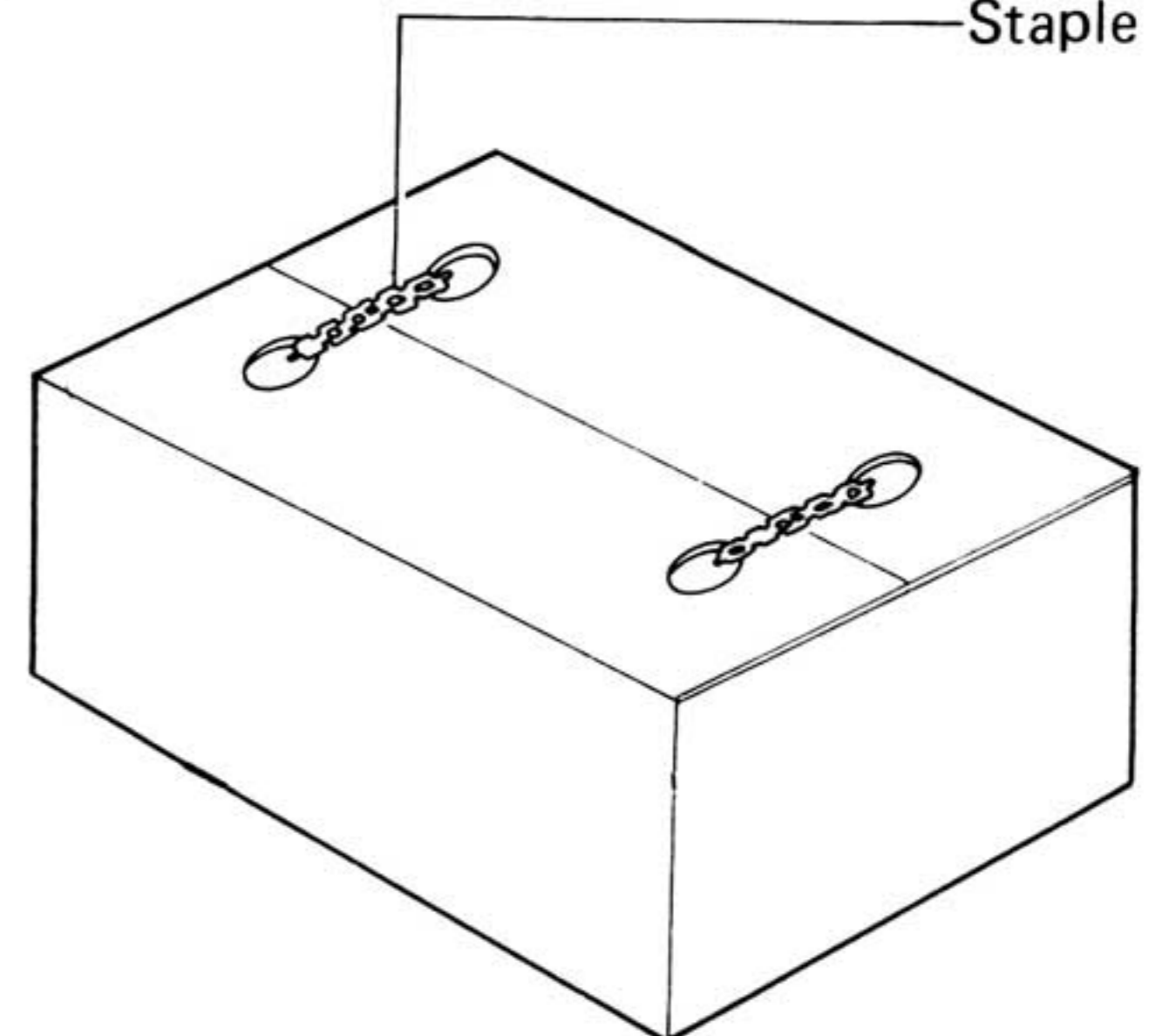

**MELCO SALES, INC.**

3030 East Victoria Street, Compton, California 90221, U.S.A.

Tel.: (213) 537-7132, Telex: 0673278

Toll Free: (800) 421-1140 (Outside of California)

SM-8061-US PRINTED IN JAPAN