

# MITSUBISHI STEREO

# POWER AMPLIFIER DA-A10DC/A15DC

## SERVICE MANUAL

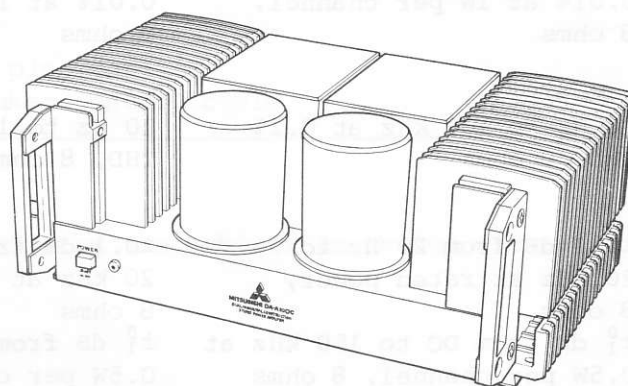

## CONTENTS

SERVICE DATA .....	2
DA-A10DC CHARACTERISTIC TABLE .....	4
DA-A15DC CHARACTERISTIC TABLE .....	5
DISCRIPTION AND FUNCTION OF EACH PART .....	6
DISASSEMBLY .....	8
ADJUSTMENT .....	9
PRINTED CIRCUIT BOARD .....	10
DA-A10DC SCHEMATIC DIAGRAM .....	11
DA-A10DC, DA-A15DC WIRING .....	13
DA-A15DC SCHEMATIC DIAGRAM .....	15
DA-A10DC PARTS LIST .....	17
DA-A15DC PARTS LIST .....	18
PACKAGE INSTRUCTION .....	19

MELCO SALES, INC.

SERVICE DATA

	DA-A10DC	DA-A15DC
Power output	100W continuous power per channel, both channels driven into 8 ohms from 15 Hz to 30 kHz, with 0.01% THD	150W continuous power per channel, both channels driven into 8 ohms from 15 Hz to 30 kHz, with 0.01% THD
Total harmonic distortion	0.005% at 50W per channel, both channels driven into 8 ohms from 20 Hz to 20 kHz	0.005% at 75W per channel, both channels driven into 8 ohms from 20 Hz to 20 kHz
Intermodulation distortion (70Hz and 7kHz 4:1)	0.008% at rated power, 8 ohms 0.01% at 1W per channel, 8 ohms	0.008% at rated power, 8 ohms 0.01% at 1W per channel, 8 ohms
Power bandwidth (IHF)	10 Hz to 100 kHz at 0.1% THD, 8 ohms	10 Hz to 100 kHz at 0.1% THD, 8 ohms
Frequency response	±0.1 dB from 20 Hz to 20 kHz at rated power, 8 ohms ± <sub>1</sub> <sup>0</sup> dB from DC to 150 kHz at 0.5W per channel, 8 ohms	±0.1 dB from 20 Hz to 20 kHz at rated power, 8 ohms ± <sub>1</sub> <sup>0</sup> dB from DC to 150 kHz at 0.5W per channel, 8 ohms
Input sensitivity/ impedance	1V (variable)/50K ohms	1V (variable)/50K ohms
Damping factor	100 from 20 Hz to 20 kHz, 8 ohms	100 from 20 Hz to 20 kHz, 8 ohms
Channel separation	100 dB at 1 kHz 80 dB at 20 kHz	100 dB at 1 kHz 80 dB at 20 kHz
Hum and noise	0.12 mV (unweighted, closed circuit)	0.15 mV (unweighted, closed circuit)
Signal to noise ratio (at rated power)	107 dB (unweighted, closed circuit) 122 dB (IHF, A network, closed circuit) 118 dB (DIN, closed circuit) 109 dB (DIN, 47K ohms// 250pF terminated)	107 dB (unweighted, closed circuit) 123 dB (IHF, A network, closed circuit) 119 dB (DIN, closed circuit) 109 dB (DIN, 47K ohms// 250pF terminated)

	DA-A10DC	DA-A15DC
Slew rate	30V/ $\mu$ s at 50V peak to peak, 8 ohms	30V/ $\mu$ s at 50V peak to peak, 8 ohms
Power consumption	600W (IEC nominal) 390W at rated power, 8 ohms 240W (UL nominal)	900W (IEC nominal) 550W at rated power, 8 ohms 320W (UL nominal)
Dimensions (W×H×D)	425 × 170 × 285 mm (16-3/4 × 6-3/4 × 11-1/4")	425 × 170 × 285 mm (16-3/4 × 6-3/4 × 11-1/4")
Weight	16 kg (35-1/4 lb)	17.7 kg (39 lb)
Supplied with:	pin plug cord speaker control cable	

Design and specifications are subject to change without notice for improvements.



DA-A10DC CHARACTERISTIC TABLE

OUTPUT POWER VERSUS HARMONIC DISTORTION CHARACTERISTIC  
(8 ohms, both channels driven)

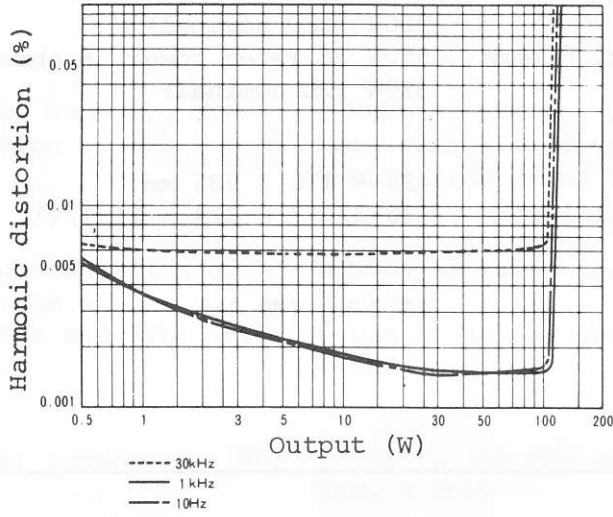

FREQUENCY VERSUS HARMONIC DISTORTION CHARACTERISTIC  
(8 ohms, both channels driven)

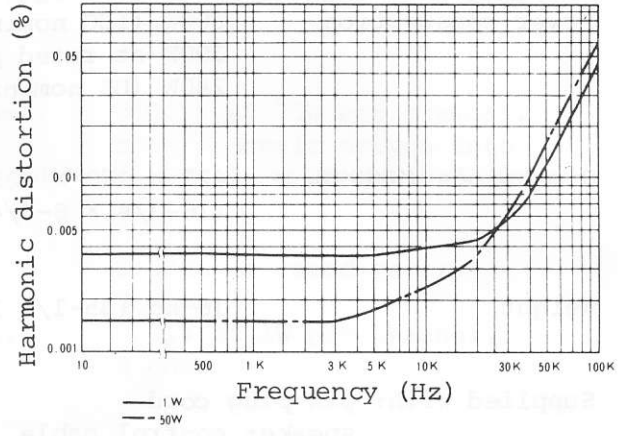

FREQUENCY RESPONSE

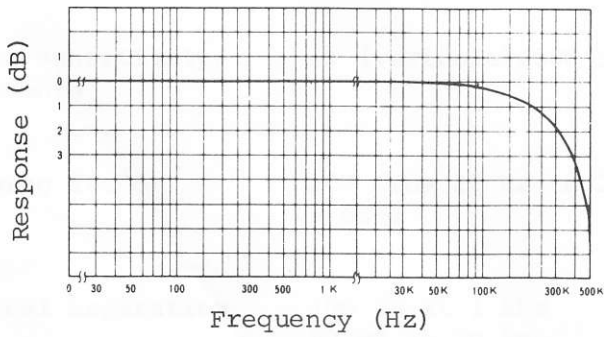

Output (1W) 8 ohms

FREQUENCY VERSUS SEPARATION CHARACTERISTIC

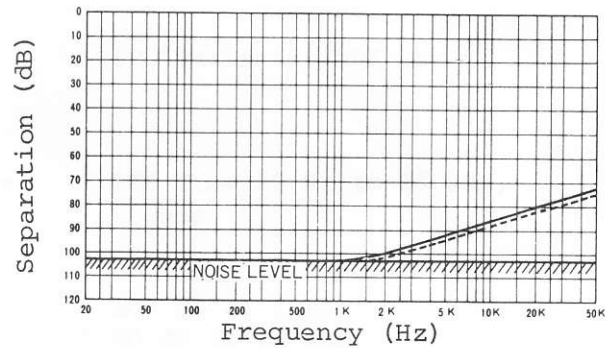

Output Rating - 3dB (50W)  
 — R → L  
 - - - L → R

DA-A15DC CHARACTERISTIC TABLE

OUTPUT POWER VERSUS HARMONIC DISTORTION CHARACTERISTIC  
(8 ohms, both channels driven)

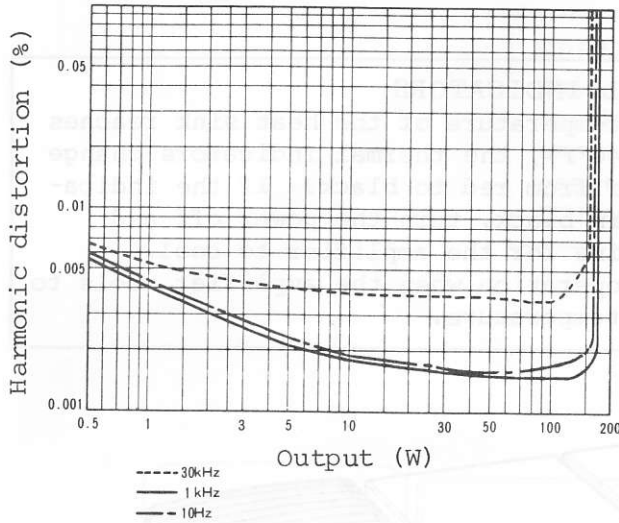

FREQUENCY VERSUS HARMONIC DISTORTION CHARACTERISTIC  
(8 ohms, both channels driven)

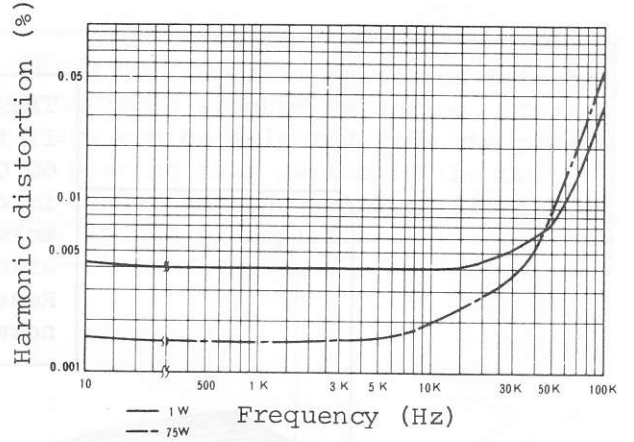

FREQUENCY RESPONSE

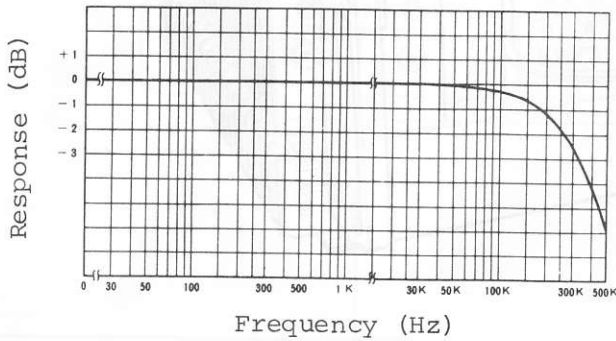

Output (1W) 8 ohms

FREQUENCY VERSUS SEPARATION CHARACTERISTIC

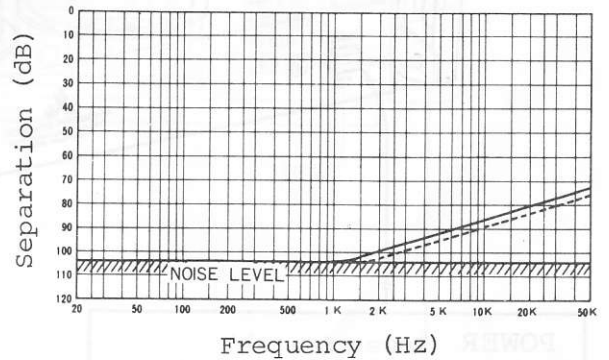

Output  
Rating - 3 dB (75W)  
—— R → L  
----- L → R

## DESCRIPTION AND FUNCTION OF EACH PART

### ■ Front Panel of DA-A10DC (DA-A15DC)

#### THERMAL INDICATORS

If the temperature of the heat sink reaches 60°C (140°F), the thermal indicators change in color from red to black. If the indicators turn black, turn the power off and allow time for the amplifier to cool. Resume operation when the amplifier cools to normal temperature.

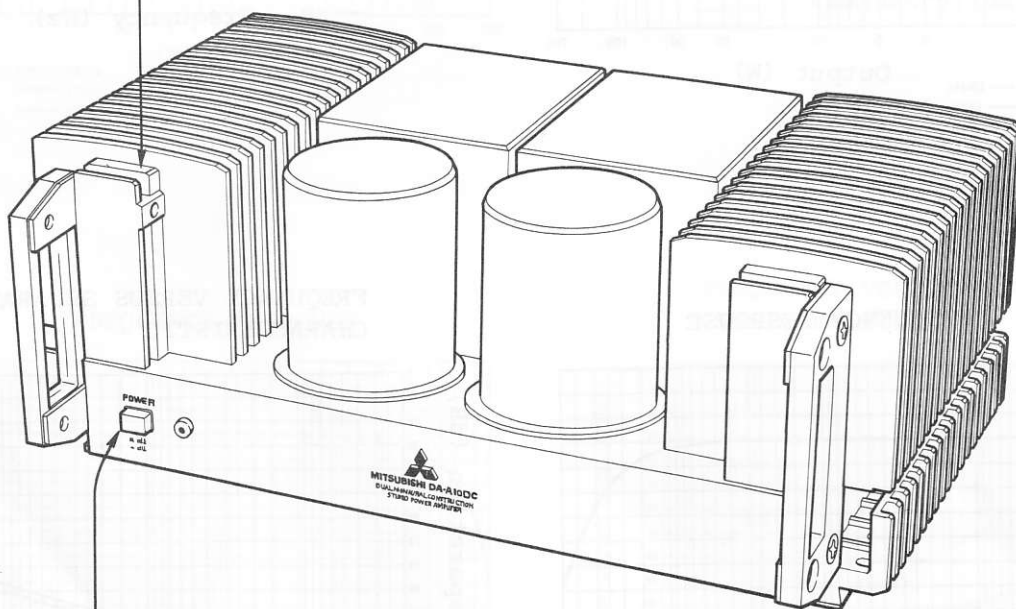

#### POWER (Power Switch)

This switch is for turning this unit on and off. When in the ON position, the power indicator is illuminated.

■ Power ON ■ Power OFF

■ Back Panel of DA-A10DC (DA-A15DC)

**SPEAKER SELECTOR (Speaker Selection Switch)**  
This switch controls speaker selection. The speaker systems can be selected from the pre-amplifier by placing this switch in the OFF position and connecting the supplied **SPEAKER CONTROL CABLE** to the preamplifier.

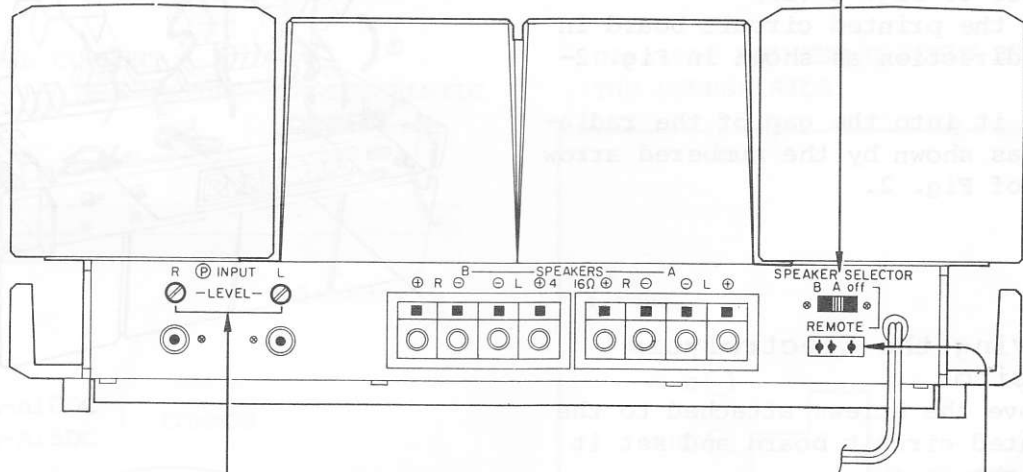

**INPUT LEVEL (Input Level Controls)**  
The input level from the preamplifier can be adjusted by these screws. To increase the input level, turn these screws clockwise. These screws are normally turned fully clockwise.

**REMOTE (Remote Terminal)**  
The connection for one end of the **SPEAKER CONTROL CABLE**. The other end is plugged into the "speaker control" terminal of a companion preamplifier.

## DISASSEMBLY

### 1. Disassembling the Bottom Cover (Fig. 1)

- 1) Remove the screws attached to the bottom cover. (Refer to Fig. 1)

Note: Since there are two types of screws used.

Description of the screws

A: M4×8 ... 4 pieces screws

B: M3×6 ... 5 pieces screws

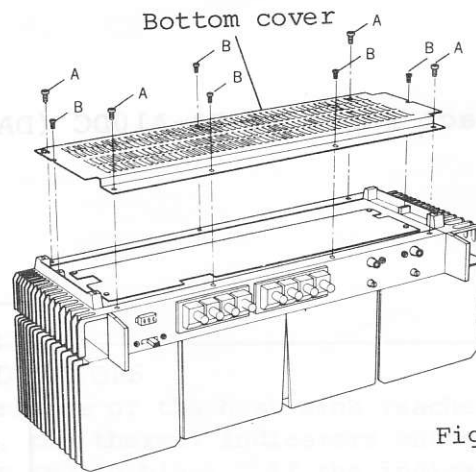

Fig. 1

### 2. Taking Out the Printed Circuit Board (Fig. 2)

- 1) Remove the screws of the bottom plate.
- 2) Remove the screws clamping the printed circuit board.
- 3) Cut the clampers binding the lead wire with a nipper. (Refer to Fig. 2-(1))
- 4) Lift the printed circuit board in the direction as shown in Fig. 2-(2).
- 5) Hold it into the gap of the radiator as shown by the numbered arrow (3) of Fig. 2.

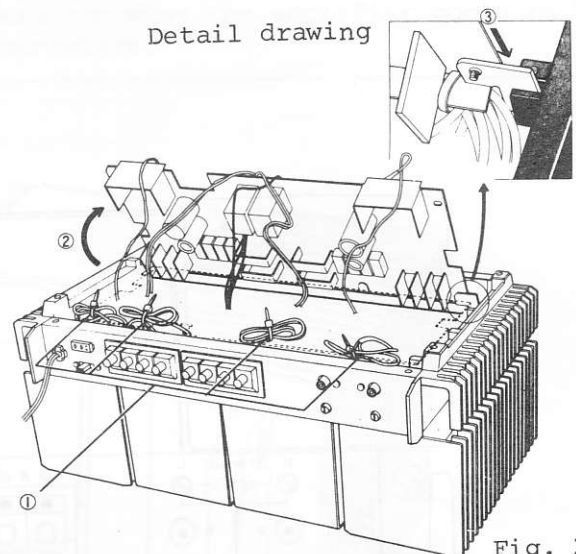

Fig. 2

### 3. Removing the Electrolytic Capacitor

- 1) Remove the screws attached to the printed circuit board and set it upright.

- 2) The capacitor cover can be removed by removing the screws as shown in Fig. 3.

M3×12: Self-tapping screws

- 3) The electrolytic capacitor is bonded to a holder.

It can be easily taken off with a slight force.

- 4) When the electrolytic capacitor is fitted, be sure to bond it properly to the holder.

\*As the electrolytic capacitor cover has its fixed mounting direction, be careful about the direction.

\*The M3×12 screws are used for attaching the capacitor cover. But the M3×16 screws should be used when the holes of the M3×12 screws are bigger.

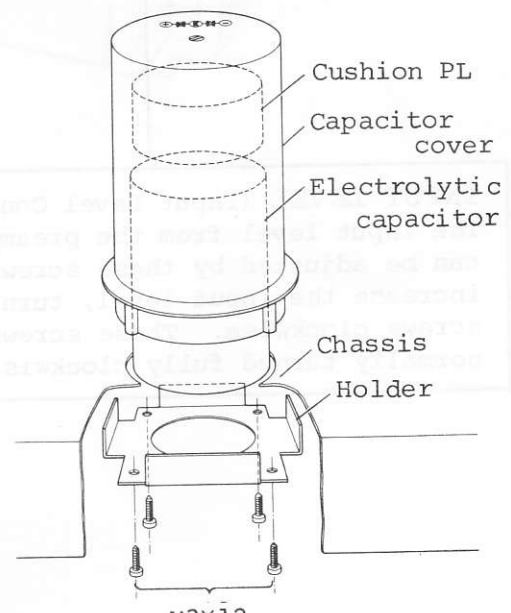

M3×12  
(Self-tapping screws) Fig. 3

ADJUSTMENT (DA-A15DC can be adjusted in the same manner as in DA-A10DC.)

### 1. Adjustment of Idling Current

- 1) Set the speaker selector switch to OFF position.
- 2) Connect a DC ammeter between the terminals (10) — (15) on the printed circuit board (MA-25) of DA-A10DC or connect it between the terminals (40) — (45) on the same circuit board (MA-25).
- 3) Rotate VR104 and VR204 and make the DC voltmeter indication minimum.
- 4) Adjust VR104 and VR204 and make the DC voltmeter indication 10 mV.
- 5) At it takes time before a steady state appears, readjust after approximately 10 minutes so that the voltmeter indicates  $50 \pm 3$  mV.

### 2. Adjustment of Neutral-Point Potential

- 1) Connect the DC voltmeter between the terminals (23) — (61) on the printed circuit board of DA-A10DC or connect it between the terminals (53) — (61) or the same printed circuit board.
- 2) Rotate VR103 and VR203 and adjust them in the mechanical center.
- 3) Make a rough adjustment of the DC voltmeter indication for  $0 \pm 5$  mV by means of the VR102. Then make a fine adjustment by means of the VR103. In the same manner, make a fine adjustment of Rch by means of VR202 after making its rough adjustment by means of VR203.

NON-SIGNAL CURRENT  
— TEMPERATURE CHARACTERISTIC

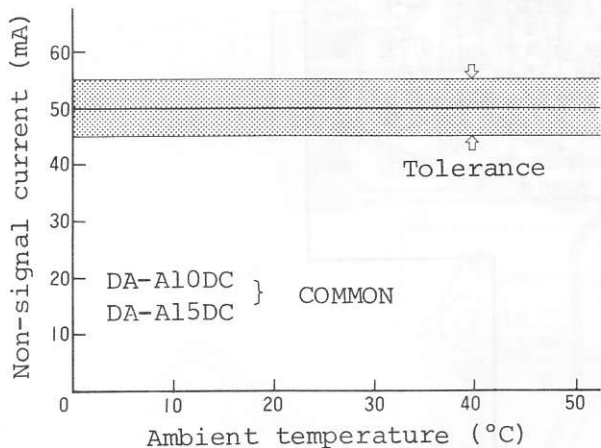

DA-A10DC PRINTED CIRCUIT BOARD ON THE COPPER SIDE

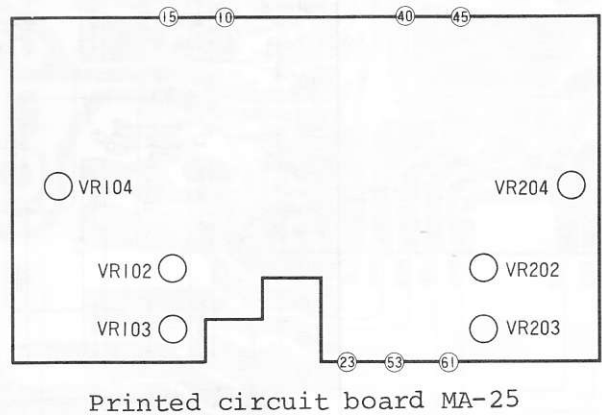



DA-A10DC SCHEMATIC DIAGRAM

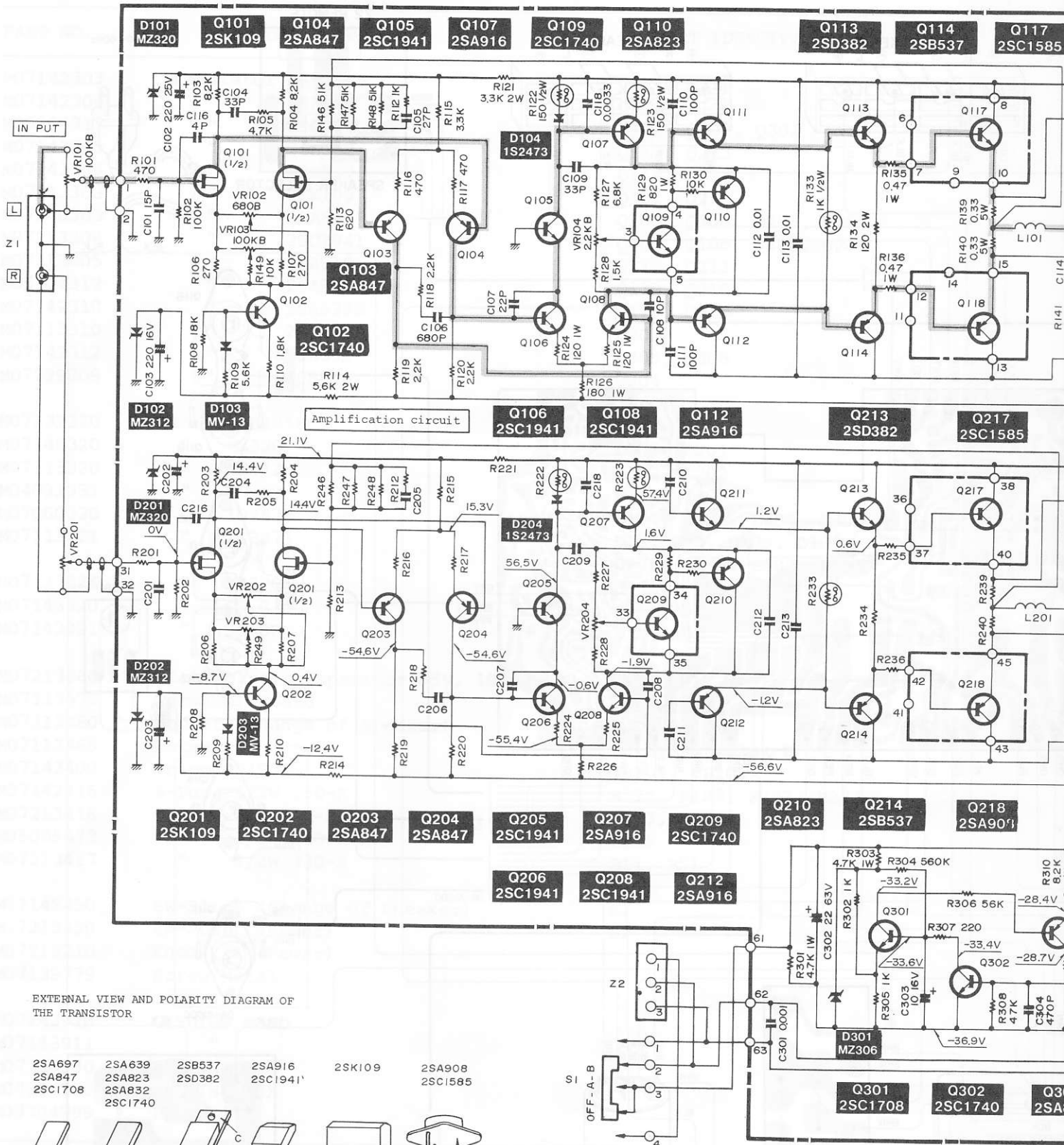

EXTERNAL VIEW AND POLARITY DIAGRAM OF THE TRANSISTOR

- |         |         |        |         |        |         |
|---------|---------|--------|---------|--------|---------|
| 2SA697  | 2SA639  | 2SB537 | 2SA916  | 2SK109 | 2SA908  |
| 2SA847  | 2SA823  | 2SD382 | 2SC1941 |        | 2SC1585 |
| 2SC1708 | 2SA832  |        |         |        |         |
|         | 2SC1740 |        |         |        |         |

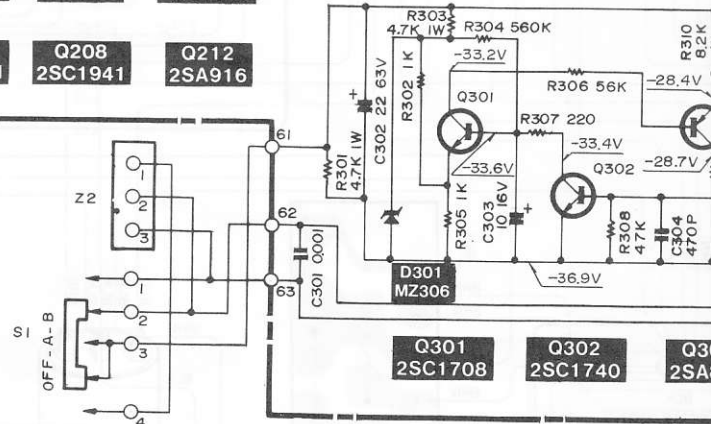
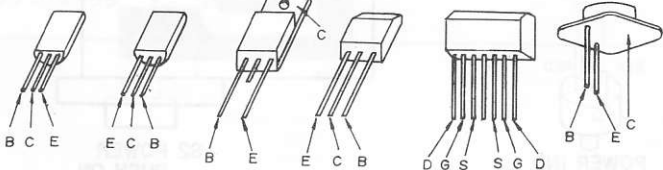

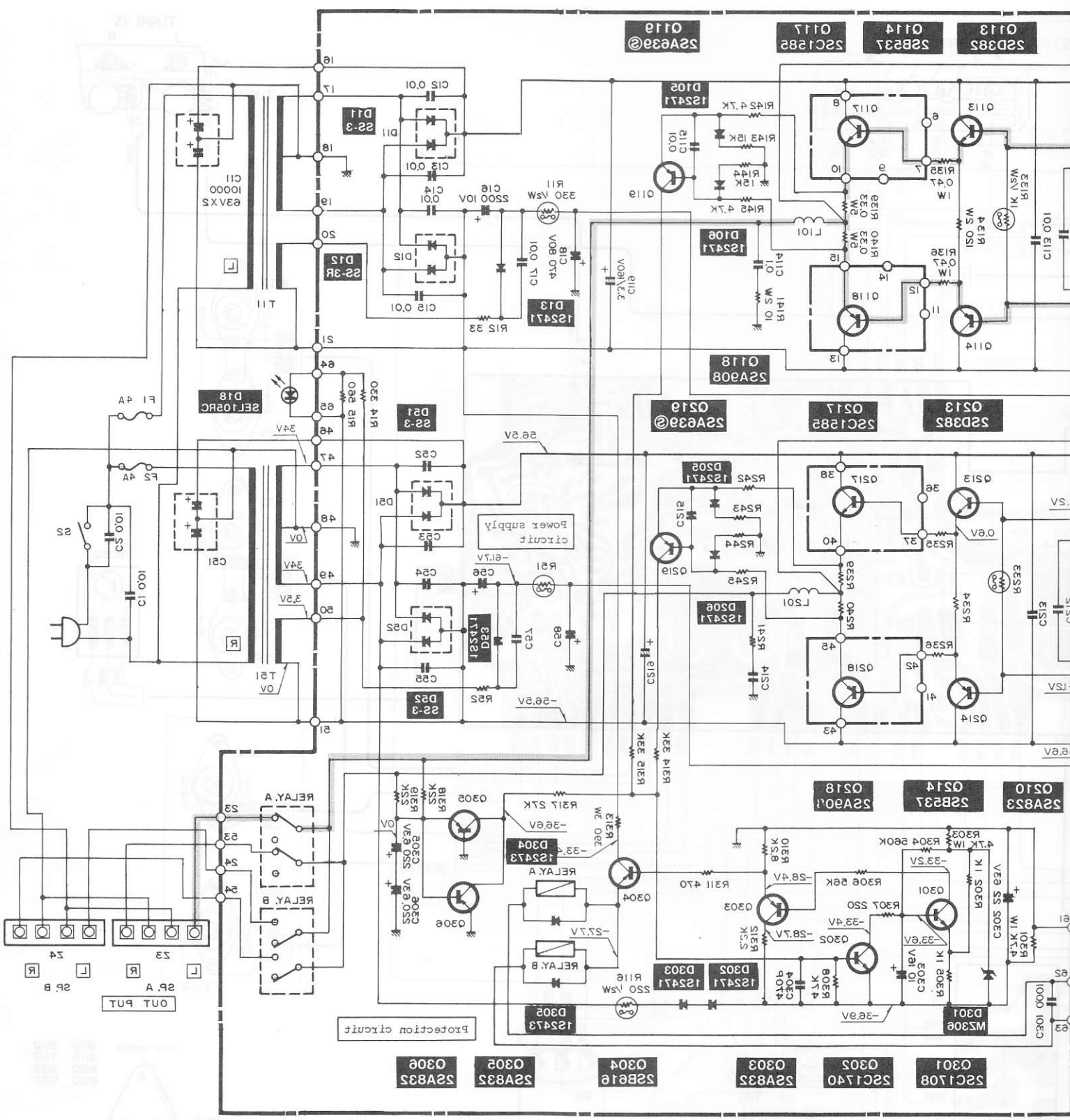

Note: 1. S1 shows SP speaker selector switch and SP-A position.  
 2. Unit of C and R  
 (1) C ... non-symptol pf  
 P symbol  
 (2) R ... non-symptol K symbol

3. The voltage in each section is the value measured by the DC 20KΩ/V tester.  
 This circuitry is a basic circuit diagram and is subject to change without notice for improvements.

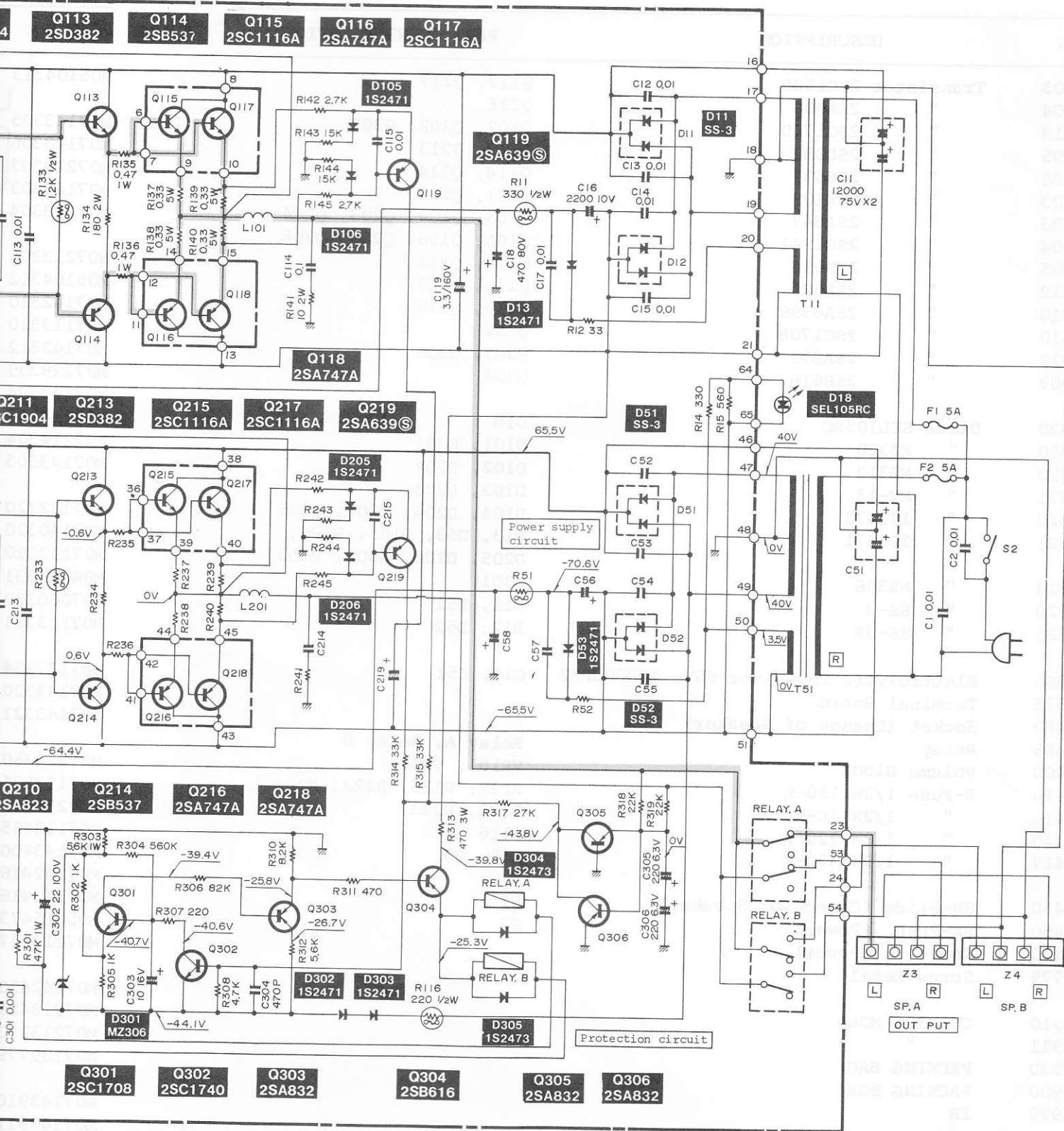

Note: 1. S1 shows SP speaker selector switch and SP-A position.  
 2. Unit of C and R  
 (1) C ... non-symbol  $\mu$ F  
 P symbol pF  
 (2) R ... non-symbol  $\Omega$   
 K symbol K $\Omega$

3. The voltage in each section is the value measured by the DC 20K $\Omega$ /V tester.  
 This circuitry is a basic circuit diagram and is subject to change without notice for improvements.

DA-A10DC, DA-A15DC WIRING

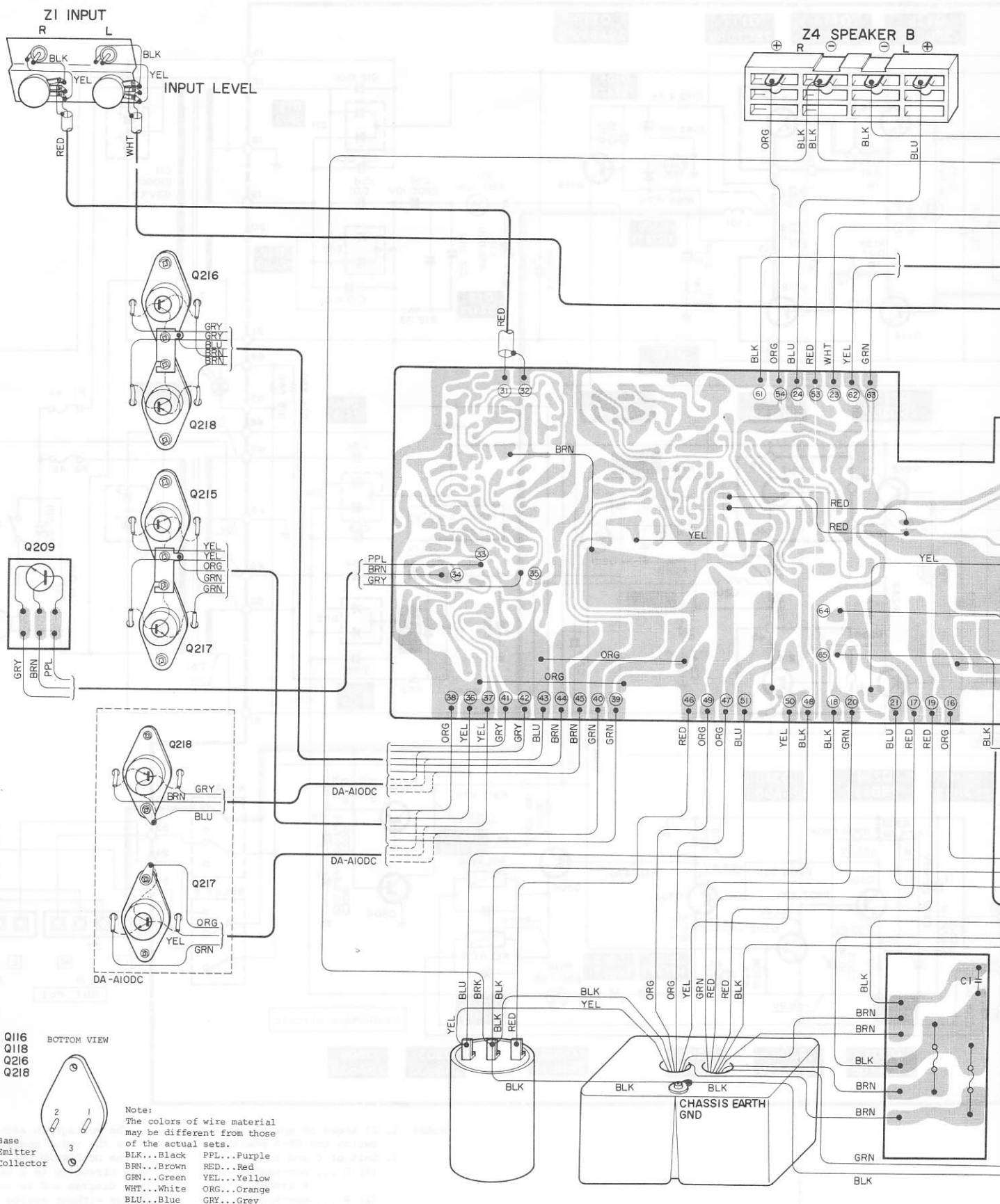

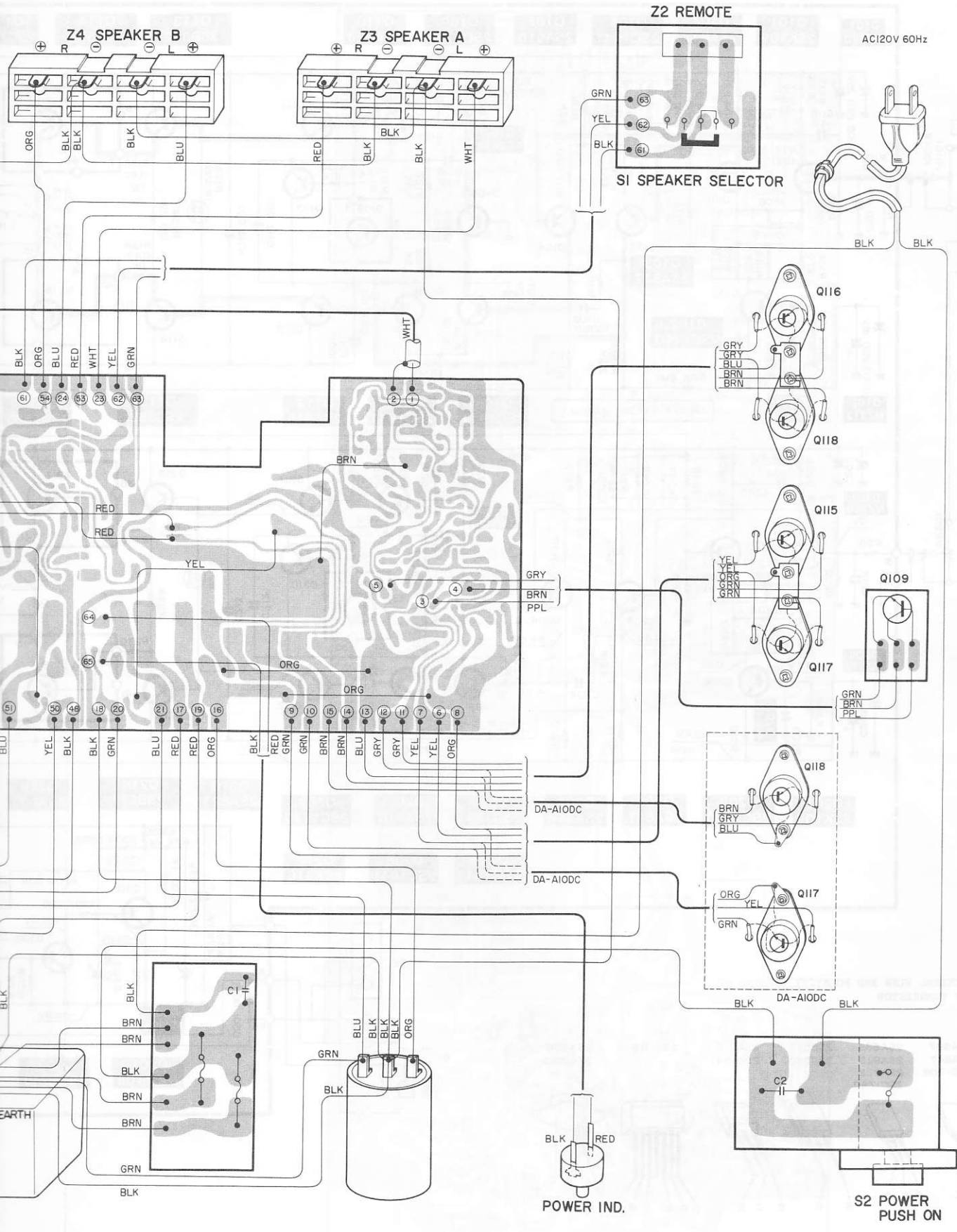

DA-A15DC SCHEMATIC DIAGRAM

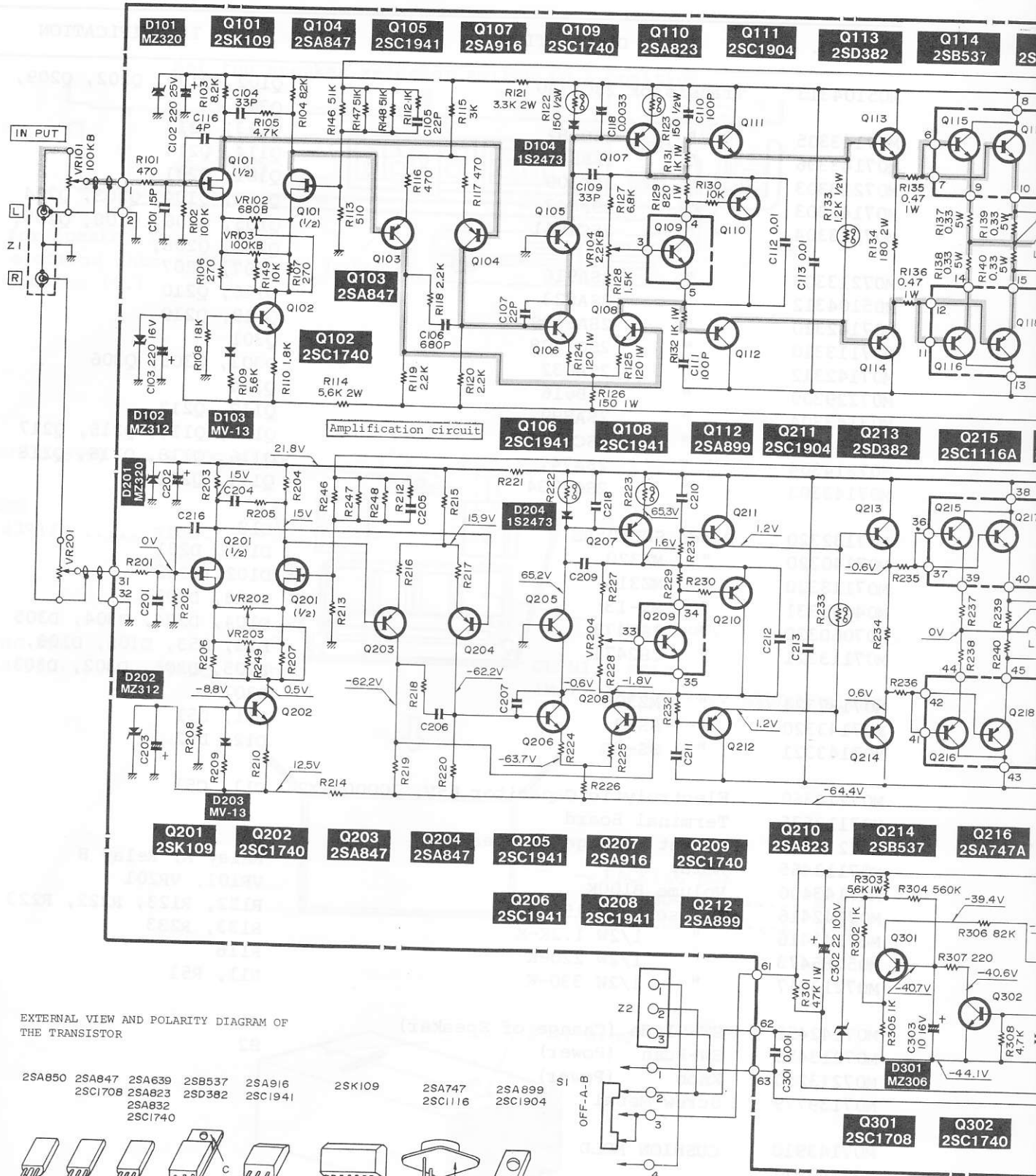

EXTERNAL VIEW AND POLARITY DIAGRAM OF THE TRANSISTOR

- |        |         |         |        |         |        |         |         |
|--------|---------|---------|--------|---------|--------|---------|---------|
| 2SA850 | 2SA847  | 2SA639  | 2SB537 | 2SA916  | 2SK109 | 2SA747  | 2SA899  |
|        | 2SC1708 | 2SA823  | 2SD382 | 2SC1941 |        | 2SC1116 | 2SC1904 |
|        |         | 2SA832  |        |         |        |         |         |
|        |         | 2SC1740 |        |         |        |         |         |

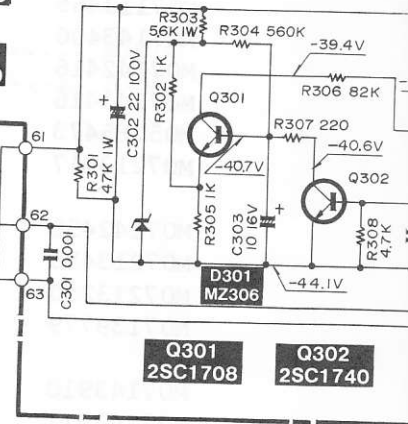
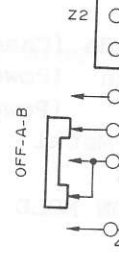
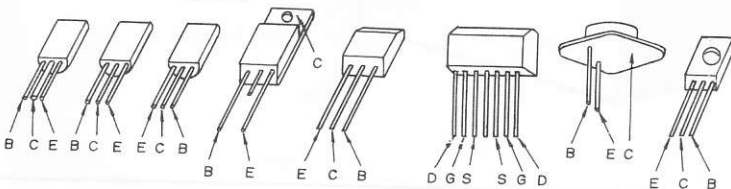

DA-A10DC PARTS LIST

PART NO.	DESCRIPTION	PART IDENTIFICATION
M07142303	Transistor 2SC1585	Q117, Q217
M07142304	" 2SA908	Q218
M05104313	" 2SC1740	Q102, Q202, Q302
M07143305	" 2SD382	Q113, Q213
M07143306	" 2SB537	Q114, Q214
M07213303	" 2SK109	Q101, Q201
M07140303	" 2SA847	Q103, Q104, Q203, Q204
M07213304	" 2SC1941	Q105, Q106, Q205, Q206
M07213305	" 2SA916	Q112, Q212
M05104312	" 2SA823	Q110, Q210
M07142310	" 2SA639S	Q119, Q219
M07113310	" 2SC1708	Q301
M07142312	" 2SA832	Q305, Q306
M07229309	" 2SB616	Q304
M07132320	Diode SEL105RC	D18
M07140320	" MZ320	D101, D201
M07113320	" MZ312	D102, D202
M04091331	" MV-13	D103, D203
M07060320	" 1S2473	D104, D204, D304, D305
M07113321	" 1S2471	D13, D53, D105, D106, D205, D206, D302, D303
M07137324	" MZ306	D301
M07143320	" SS-3	D11, D51
M07143321	" SS-3R	D12, D52
M07213360	Electrolytic Capacitor 65V, 10000 $\mu$ F $\times$ 2	C11, C51
M07113575	Terminal Board	
M07213480	Socket (Change of Speaker)	
M07113465	Relay	Relay A, Relay B
M07143400	Volume B100K	VR101, VR201
M07142416	R-Fuse 1/2W 150-K	R122, R123, R222, R223
M07213416	" 1/2W 1K-K	R133, R233
M05085473	" 1/2W 220-K	R116
M07213417	" 1/2W 330-K	R11, R51
M07142450	SW-Slide (Change of Speaker)	S1
M07213450	SW-Push (Power)	S2
M07213210	Knob (Power)	
M07139779	Screw Metal	
M07143910	CUSHION MOLD	
M07143911	"	
M07143930	PACKING BAG	
M07304900	PACKING BOX	
M07304999	IB	

DA-A15DC PARTS LIST

DA-A15DC SCHEMATIC DIAGRAM

PART NO.	DESCRIPTION	PART IDENTIFICATION
M05104313	Transistor 2SC1740	Q102, Q109, Q202, Q209, Q302,
M07143305	" 2SD382	Q113, Q213
M07143306	" 2SB537	Q114, Q214
M07213303	" 2SK109	Q101, Q201
M07140303	" 2SA847	Q103, Q104, Q203, Q204
M07213304	" 2SC1941	Q105, Q106, Q108, Q205, Q206, Q208,
M07213305	" 2SA916	Q107, Q207
M05104312	" 2SA823	Q110, Q210
M07142310	" 2SA639S	Q119, Q219
M07113310	" 2SC1708	Q301
M07142312	" 2SA832	Q303, Q305, Q306
M07229309	" 2SB616	Q304
M07143304	" 2SA899	Q112, Q212
M07214303	" 2SC1116	Q115, Q117, Q215, Q217
M07214304	" 2SA747	Q116, Q118, Q216, Q218
M07143303	" 2SC1904	Q111, Q211
M07132320	Diode SEL105RC	D18
M07140320	" MZ320	D101, D201
M07113320	" MZ312	D102, D202
M04091331	" MV-13	D103, D203
M07060320	" 1S2473	D104, D204, D304, D305
M07113321	" 1S2471	D13, D53, D105, D106, D205, D206, D302, D303
M07137324	" MZ306	D301
M07143320	" SS-3	D11, D51
M07143321	" SS-3R	D12, D52
M07214360	Electrolytic Capacitor 65V, 10000µF×2	C11, C51
M07113575	Terminal Board	
M07213480	Socket (Change of Speaker)	
M07113465	Relay	Relay A, Relay B
M07143400	Volume B100K	VR101, VR201
M07142416	R-Fuse 1/2W 150-K	R122, R123, R222, R223
M07143416	" 1/2W 1.2K-K	R133, R233
M05085473	" 1/2W 220-K	R116
M07213417	" 1/2W 330-K	R11, R51
M07142450	SW-Slide (Change of Speaker)	S1
M07213450	SW-Push (Power)	S2
M07213210	Knob (Power)	
M07139779	Screw Metal	
M07143910	CUSHION MOLD	
M07143911		
M07143930	PACKING BAG	
M07305900	PACKING BOX	
M07304999	IB	

PACKAGE INSTRUCTION

Set the speaker selector switch to A position.

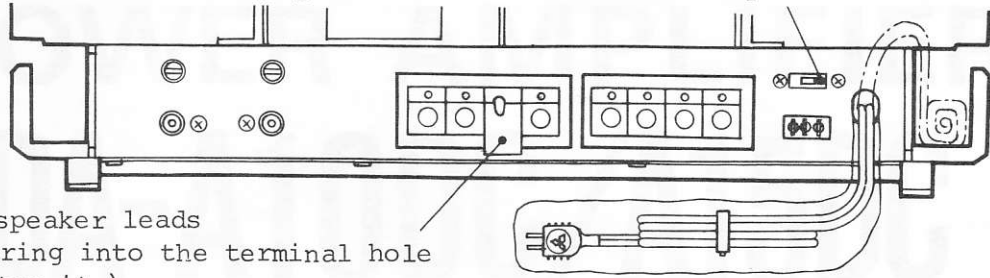

Note for speaker leads  
(Put a string into the terminal hole  
and tighten it.)

IB (M07304999) ... A10DC, A15DC

CUSHION  
(M07143911) ..... A10DC,  
A15DC

PACKING BAG  
(M07143930) ..... A10DC, A15DC

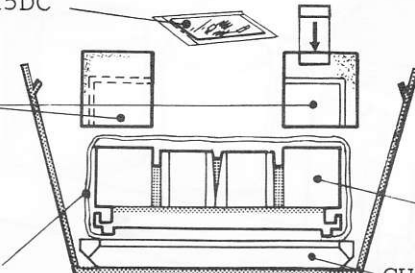

Main body

CUSHION MOLD  
(M07143910) ..... A10DC, A15DC

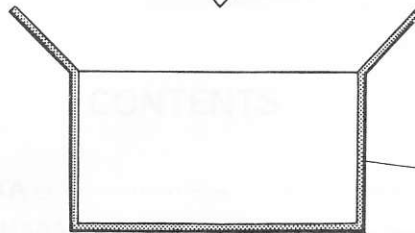

PACKING BOX  
(M07304900) ..... A10DC  
(M07305900) ..... A15DC

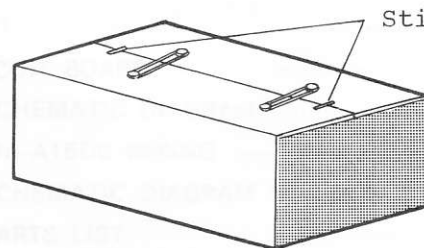

Stitching

Speaker Selector Switch

Set the speaker selector switch to A position.

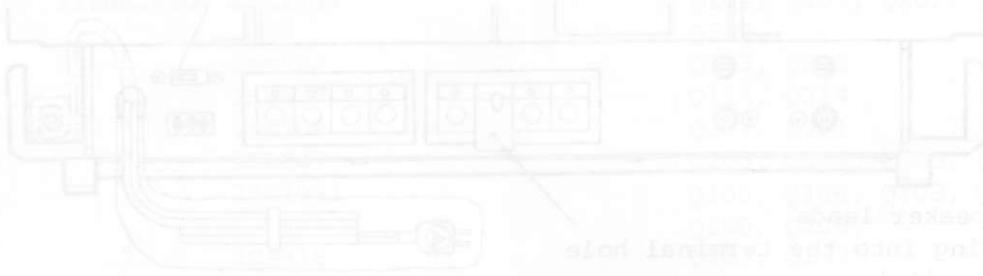

Note for speaker leads: Put a string into the terminal hole and tighten it.

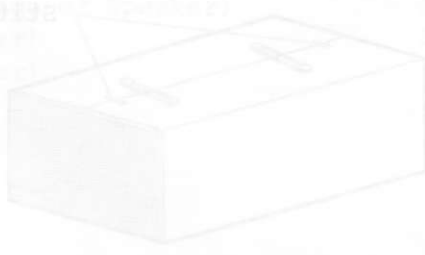
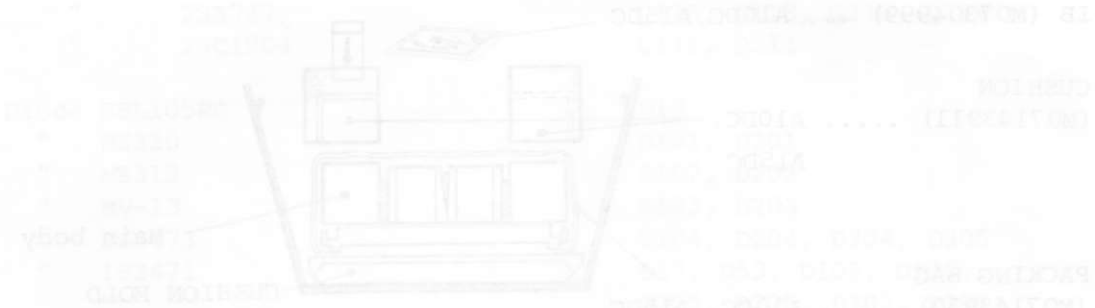

MELCO SALES, INC.

3030 East Victoria Street, Compton, California 90221, U.S.A.  
Tel.: (213) 537-7132, Telex: 0673278  
Toll Free: (800) 421-1132 (Outside of California)