

SERVICE MANUAL

marantz

model 3250B

Stereo Control Console

MARANTZ DESIGN AND SERVICE

Using superior design and selected high grade components, MARANTZ Company has created the ultimate in stereo sound. Only original MARANTZ parts can insure that your MARANTZ product will continue to perform to the specifications for which it is famous.

Parts for your MARANTZ stereo are generally available within 72 hours throughout the nation via a toll-free line to our National Parts Depot in California. The sales professionals who take your call immediately refer to their own desk top computer terminal and can quickly determine the availability and price information you require. If for some reason, your order should exceed our available stock, we usually can instantly provide an alternate replacement part or current delivery information. When the order is placed and confirmed, the computer simultaneously generates "hard copy" orders at the distribution center. As hard copies come directly from the computer to the national parts depot, your requested stock is assembled and prepared for shipment and placed on the first available carrier for delivery to you.

ORDERING PARTS

Phone orders will eliminate mail delays, and we encourage the use of this method. If you order by mail, use MARANTZ parts order forms which are available from our National Parts Depot located at the following address:

SUPERSCOPE NATIONAL PARTS DEPARTMENT
 20525 Nordhoff Street
 Chatsworth, California 91311
 Phone: 1-800-423-5108
 1-213-998-9333

The following information must be supplied to eliminate delays in processing your order:

1. Complete address.
2. Complete part numbers.
3. Complete description of parts.
4. Model number for which part is required (indicate MARANTZ).
5. Account number (for account customers only).

Direct consumers will be provided with the current retail price quotation on available parts in order to advise them of the cost of the parts and shipping.

OVERSEAS PARTS ORDERING

Parts may also be ordered from the following overseas addresses:

CANADA

Superscope Canada, Ltd.
 3710 Nashua Drive
 Mississauga
 Ontario, Canada L4V1M5

AUSTRALIA

Superscope (Australasia) Pty., Ltd.
 32 Cross Street (P.O. Box 604)
 Brookvale 2100 N.S.W.
 Australia

JAPAN

Marantz Japan, Inc.
 3622 Kamitsuruma
 Sagamihara Shi
 Kanagawa, Japan

EUROPE

Superscope Europe, S.A.
 Avenue Leopold III, 2
 7120 Perennes-Lez-Binche
 Belgium

Marantz France
 Rue Louis Armand 9
 92600 Asnieres
 Hauts-de-Seine
 France

Marantz Audio U.K. Ltd.
 London Road, 203
 Staines
 Middlesex
 England

Superscope GmbH
 Max-Planck-Strasse 22
 D-6072 Dreieich 1
 West Germany

All of the above locations are fully equipped to take care of your total service needs. Because various countries have differing configuration requirements, it is necessary that you contact the service facility in your particular country. In the event that there is no service location listed for your country, please contact the nearest facility for the necessary assistance.

TABLE OF CONTENTS

SECTION	PAGE
1. INTRODUCTION	1
2. PW BOARD	1
3. TEST EQUIPMENT REQUIRED FOR SERVICING	1
4. ALIGNMENT	2
5. VOLTAGE CONVERSION FOR EUROPE	2
6. BLOCK DIAGRAM	3
7. SCHEMATIC DIAGRAM	4
8. DIAGRAM AND COMPONENT LOCATIONS	6
8.1 SPK/Headphone Assembly (PW01) Schematic Diagram and Component Locations	6
8.2 Pre-Amp Assembly (PJ01) Schematic Diagram and Component Locations	6
8.3 Loudness Control (PF01) Schematic Diagram and Component Locations	7
8.4 Fuse Assembly (PP01) Schematic Diagram and Component Locations	8
8.5 Input Terminal (PV01) Schematic Diagram and Component Locations	9
8.6 Tone Control Filter (PS01) Schematic Diagram and Component Locations	10
9. EXPLODED MECHANICAL DIAGRAM	11
9.1 Rear Panel for Europe only	11
10. PACKING MATERIAL EXPLODED VIEW	14
11. PARTS LIST	15
12. TECHNICAL SPECIFICATIONS	22

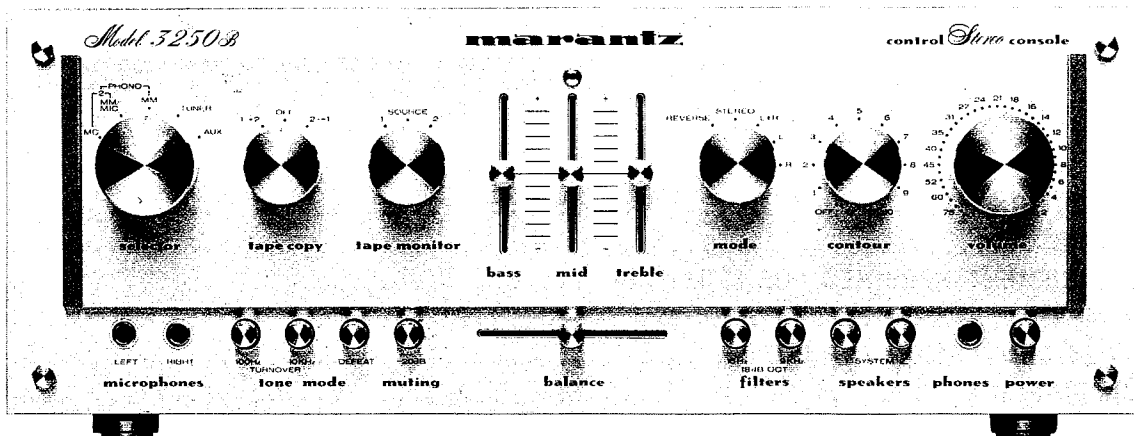

1. INTRODUCTION

This service manual was prepared for use by Authorized Warranty Stations and contains service information for Marantz Model 3250B Stereo Control Console. Servicing information and voltage data included in this manual are intended for use by knowledgeable and experienced personnel only. All instructions should be read carefully. No attempt should be made to proceed without a good understanding of circuitry operation. The parts list furnishes complete ordering information. Most replacement parts should be ordered from the Marantz Company. However, a simple description is included for parts which can be obtained locally.

2. P.W. BOARD

As can be seen from the circuit diagram, the chassis of Model 3250B consists of following units. Each unit mounted on a printed circuit board is described within the square enclosed by a bold dotted line on the circuit diagram.

1. Tone-Amp. Ass'y mounted on P.W.B. PJ 01
2. Tone Control, Filter Ass'y mounted on P.W.B. PS 01
3. Input Terminal Ass'y mounted on P.W.B. PV 01
4. Speaker/Headphone Ass'y mounted on P.W.B. PW 01
5. Fuse Ass'y mounted on P.W.B. PP 01
6. Loudness Control Ass'y mounted on P.W.B. PF 01

3. TEST EQUIPMENT REQUIRED FOR SERVICING

Table 1 lists the test equipment required for servicing the Model 3250B Stereo Control Console.

Item	Manufacturer and Model No.	Use
Distortion Analyzer Audio Oscillator AC VTVM	Sound Technology Model 1700B	Distortion measurements Sinewave and swuarewave signal source Voltage measurements (AC)
Oscilloscope	Tektronix Model T932 Philips Model 3232	Waveform analysis and trouble shooting
Circuit Tester		Trouble shooting
DC VTVM	Fluke Model 8000 "Digital" Simpson Model 313, Triplet Model 801	Voltage measurements (DC)
AC Wattmeter	Simpson Model 1379	Monitors primary power to amplifier
AC Ammeter	Commercial Grade (1-10A)	Monitors amplifier output under short circuit condition
Line Voltmeter	Simpson Model 1359	Monitors potential of primary power to amplifier
Variable Autotransformer	Superior Electronic Co., Powerstat Model 116B - 10 A	Adjusts level of primary power to amplifier
Shorting Plug	Use phono plug with 600 ohm across center pin and shell	Shorts amplifier input to eliminate noise pickup

4. ALIGNMENT PROCEDURES

1. Set the VOLUME control at maximum, and also BASS, MID, TREBLE and BALANCE Controls at mechanical center position.
2. Connect 47 kΩ dummy load resistor to each R and L channel on PRE OUT jacks of the unit.

ITEM	SIGNAL APPLICATION	INDICATOR CONNECTION
CHECK OF THE TECHNICAL SPEC.	PHONO, AUX, TAPE	TAPE OUT, PRE OUT

5. VOLTAGE CONVERSION

● EUROPEAN MODEL ONLY

This Model is equipped with a universal power transformer to permit operation at 110, 120, 220 and 240V AC 50/60 Hz.

To convert the unit to the required voltage, set the plug as illustrated so that you can adjust the voltage as required.

CAUTION

DISCONNECT POWER SUPPLY CORD FROM AC OUTLET BEFORE CONVERTING VOLTAGE.

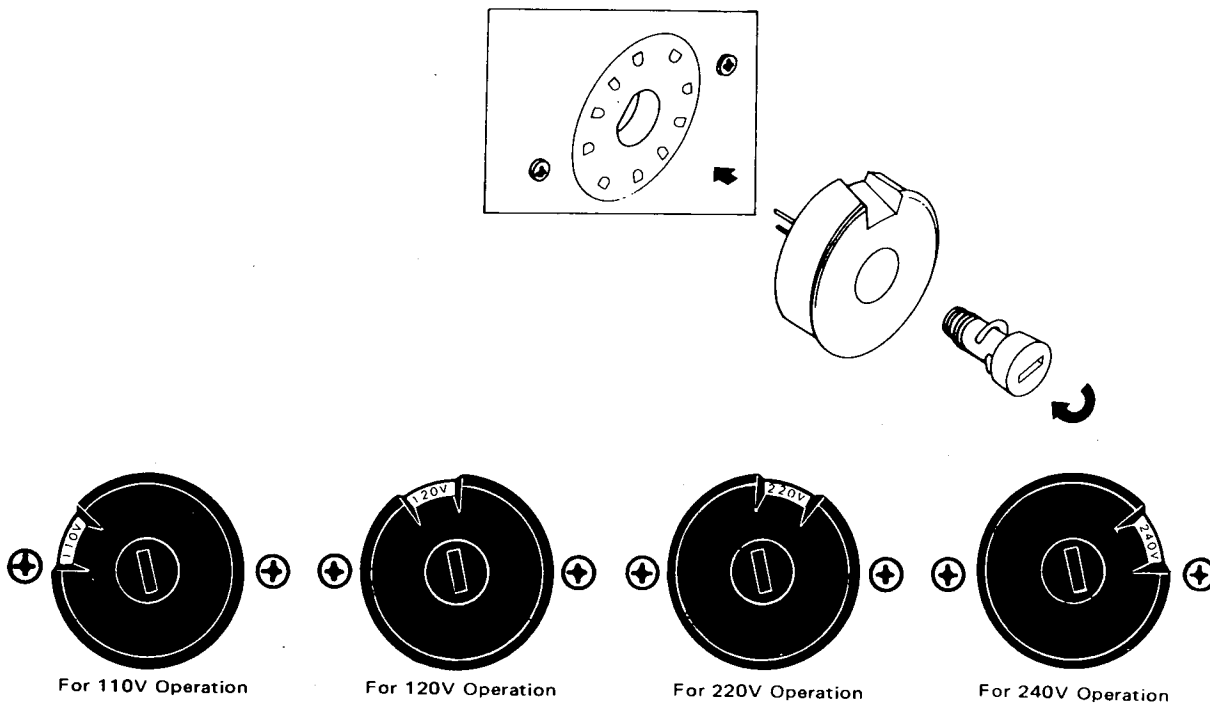

6. BLOCK DIAGRAM

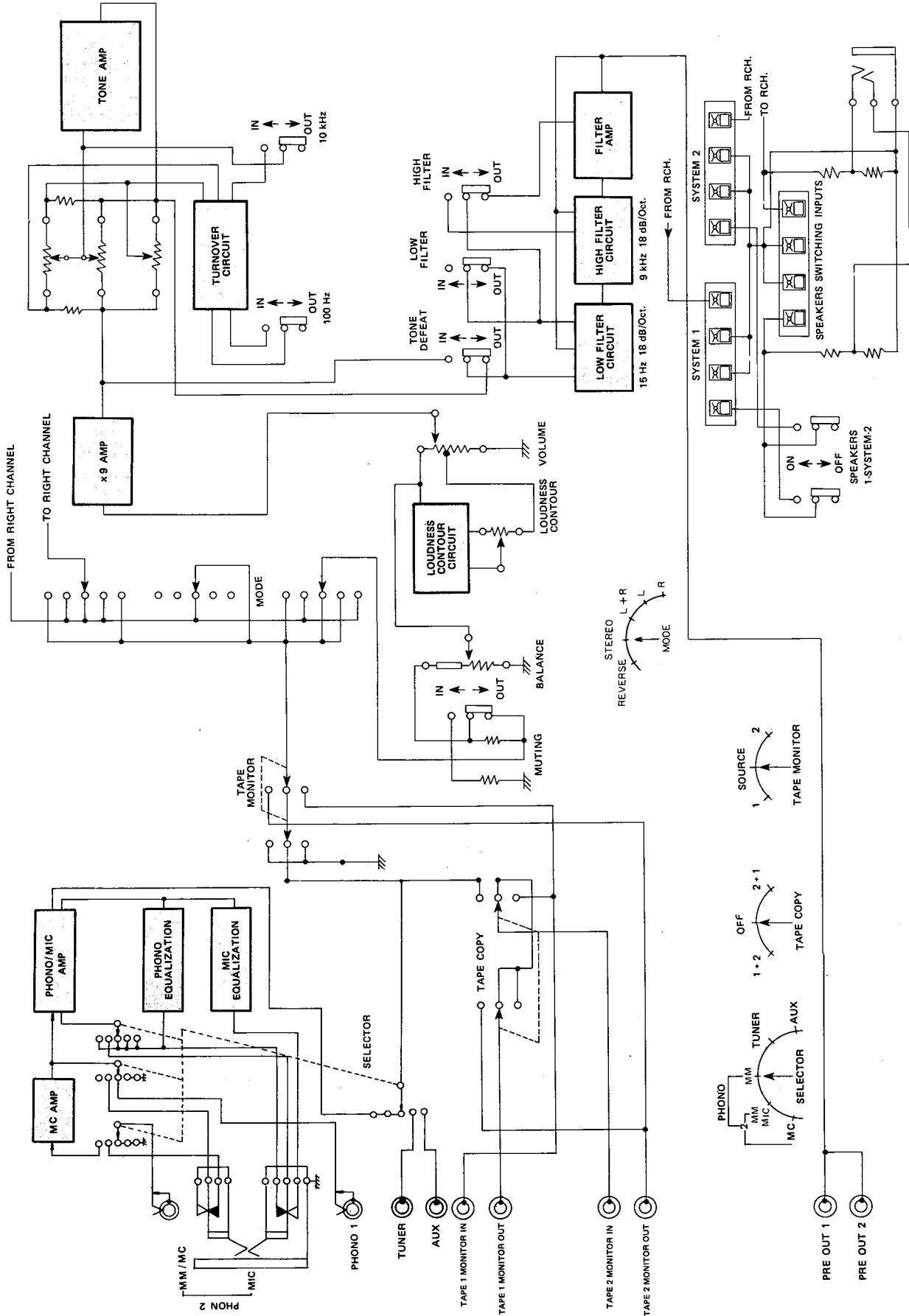
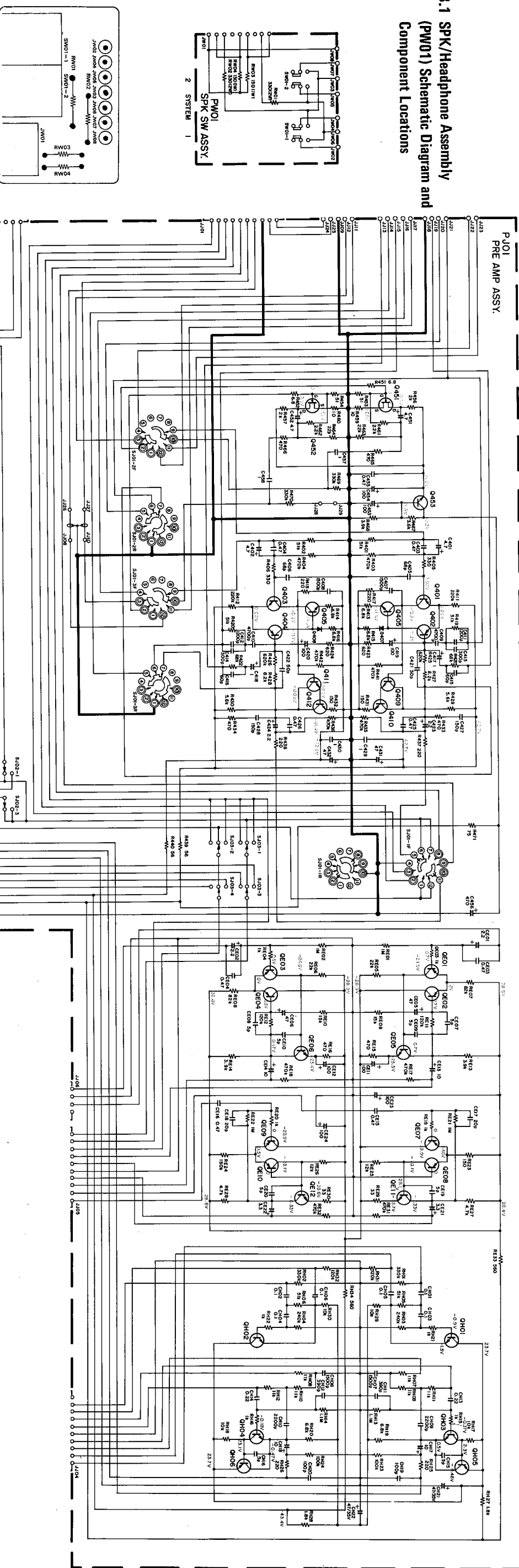

Figure 10. Functional Block Diagram

8. DIAGRAM AND COMPONENT LOCATIONS

8.2 Pre-Amp Assembly (PJ01) Schematic Diagram and Component Locations



8.1 SPK/Headphone Assembly (PW01) Schematic Diagram and Component Locations

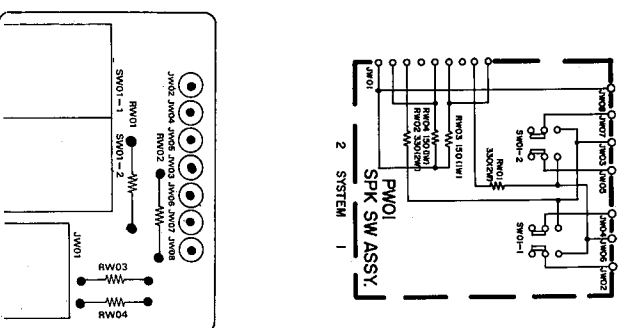

8.3 Loudness Control (PF01) Schematic Diagram and Component Locations

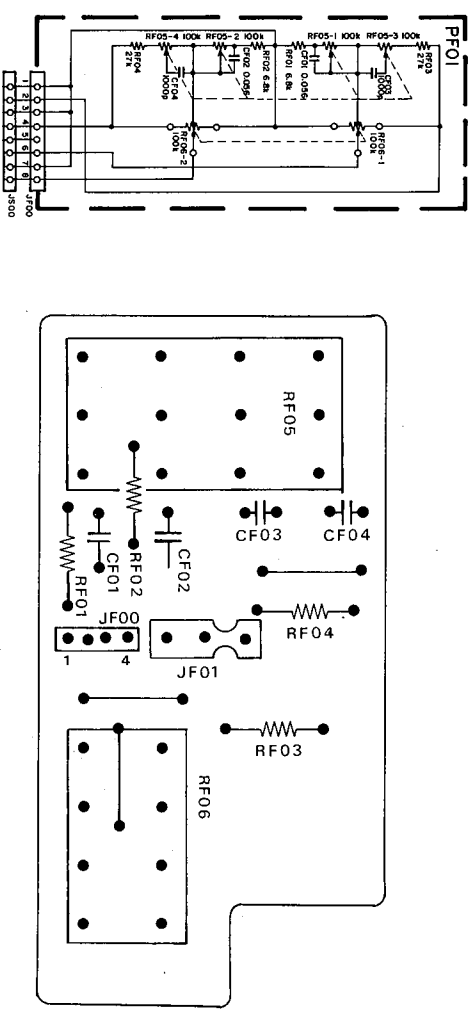

7. SCHEMATIC DIAGRAM

Model 3250B

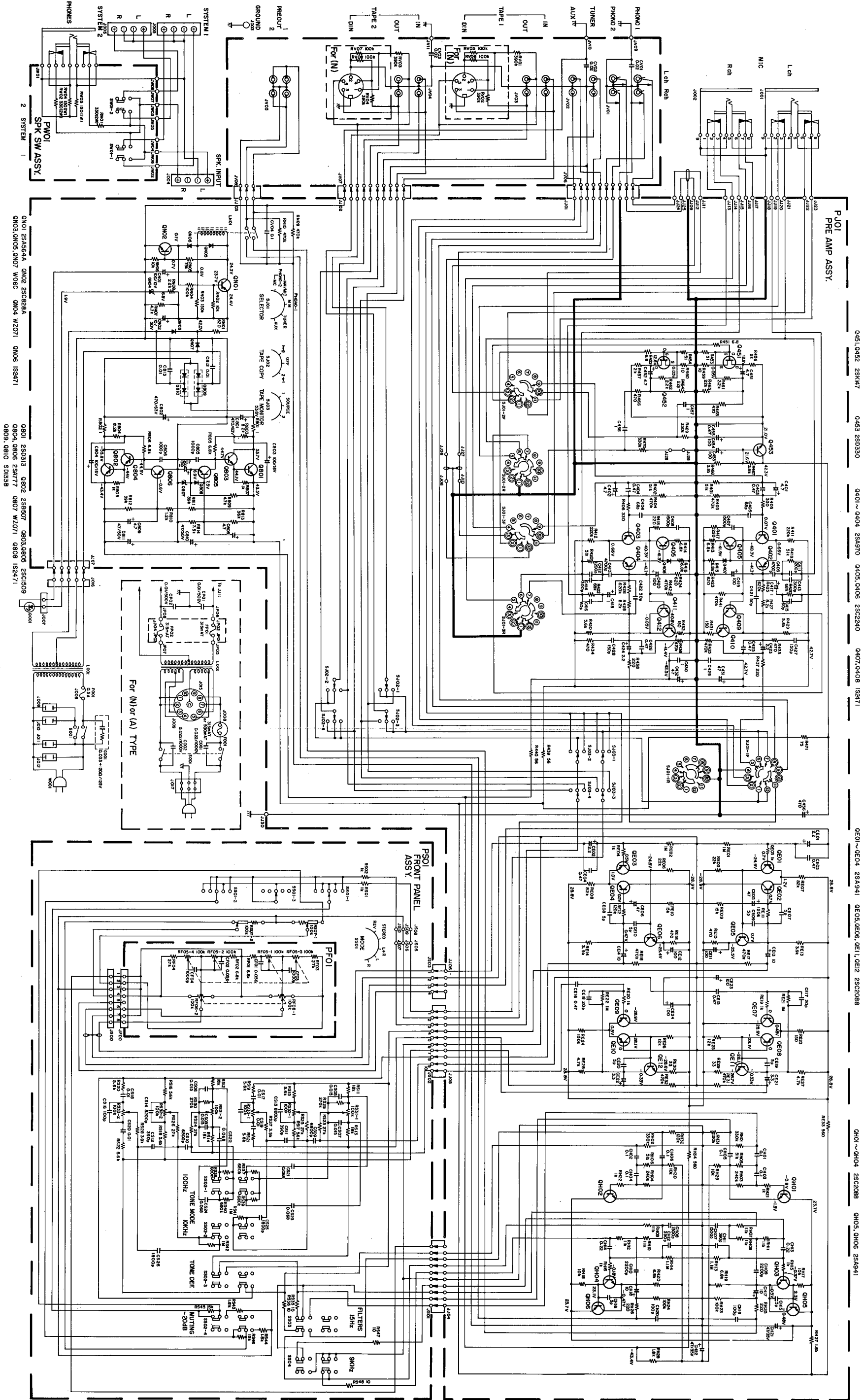

- Q451, Q452 25K47 Q453 25D330 Q401 ~ Q404 25A970 Q405, Q406 25C2240 Q407, Q408 152471
- Q501 ~ Q504 25A941 Q505, Q506, Q511, Q512 25C2088
- Q601 ~ Q604 25C2088 Q605, Q606 25A941

8.6 Tone Control Filter (PS01) Schematic Diagram and Component Locations

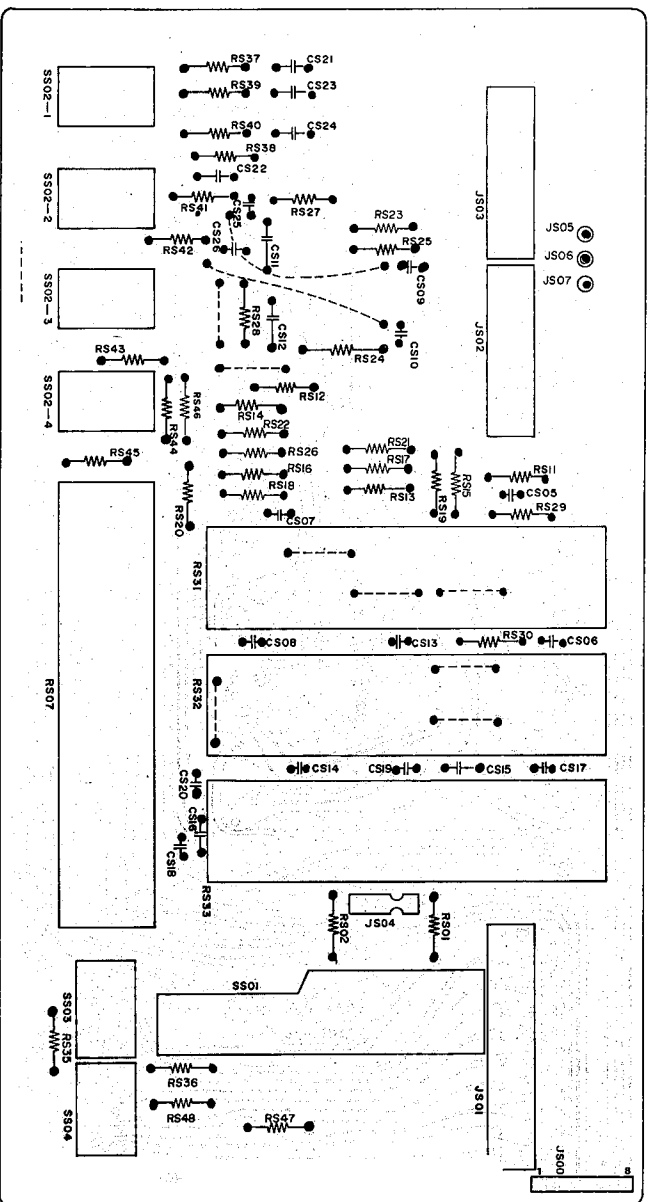
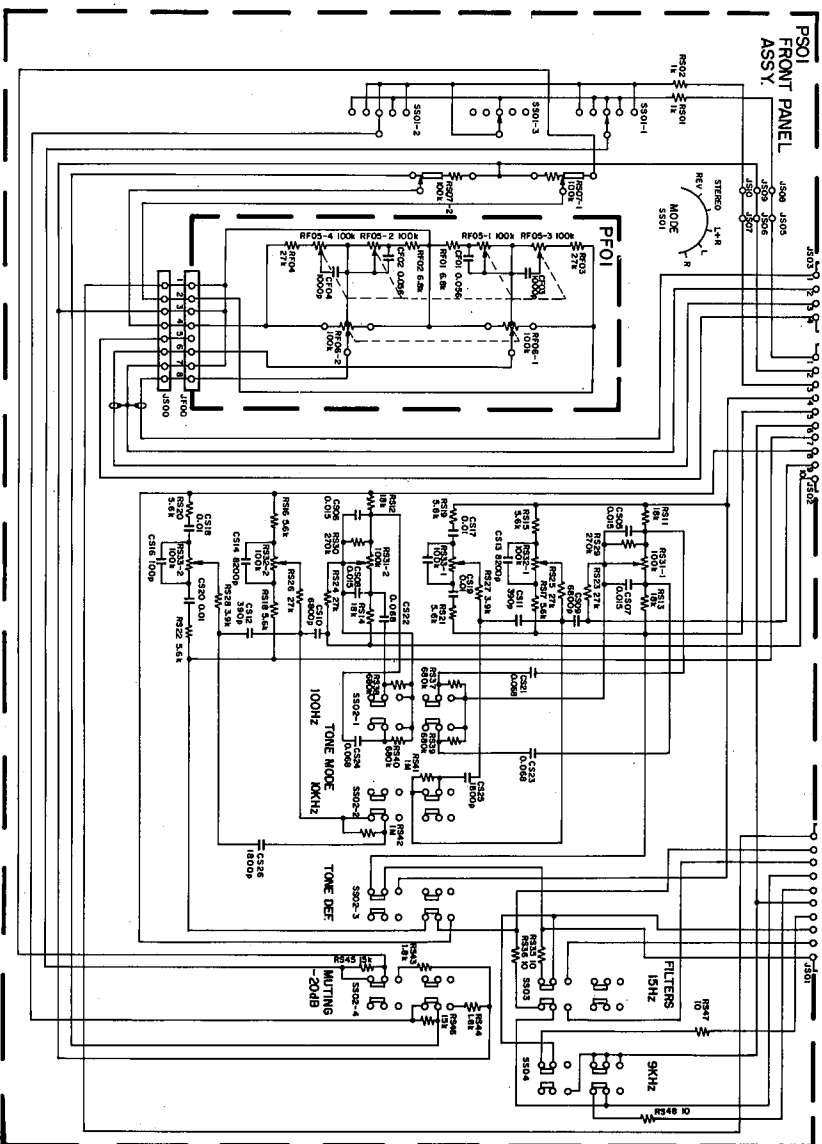

9. EXPLODED MECHANICAL DIAGRAM

9.1 Rear Panel for Europe only

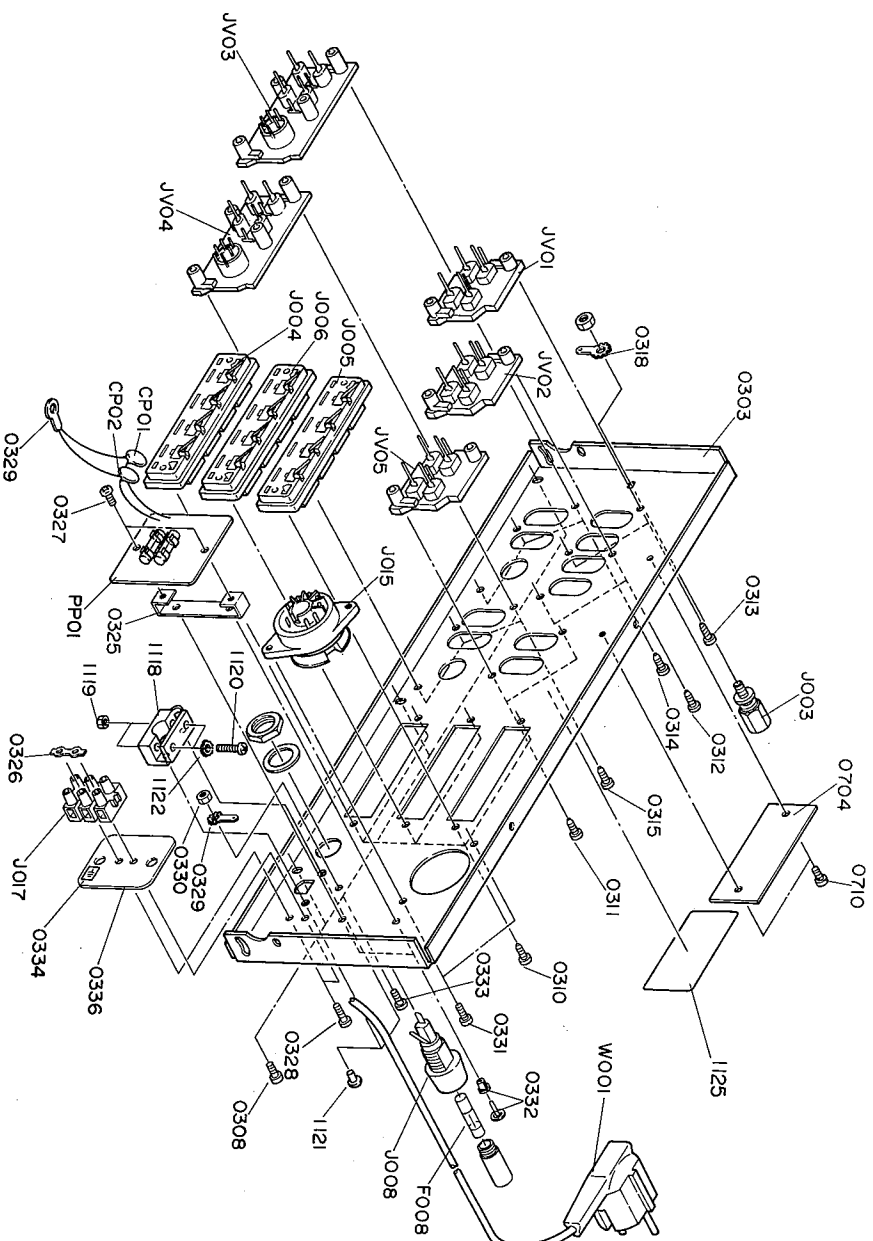

8.5 Input Terminal (PV01) Schematic Diagram and Component Locations

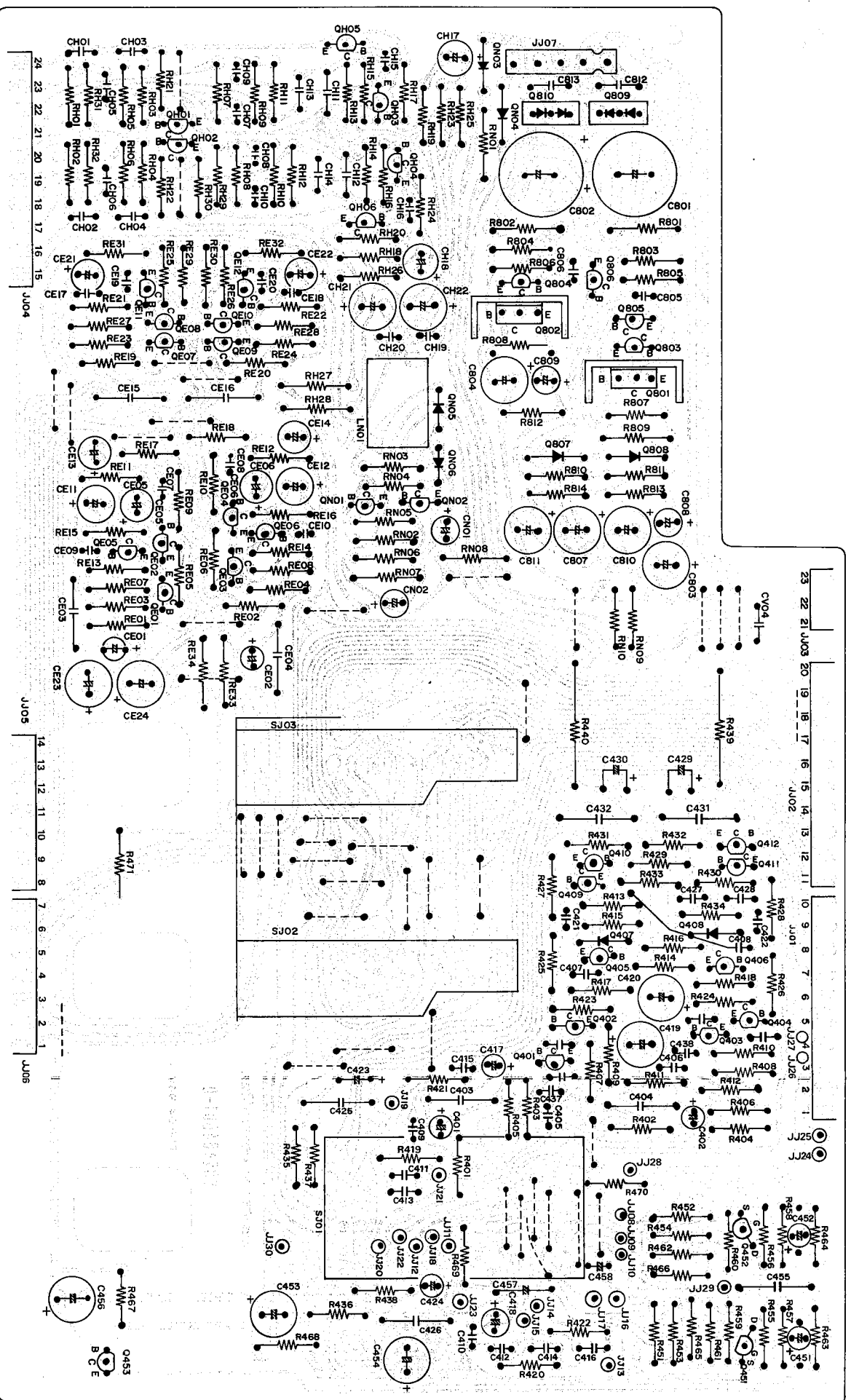
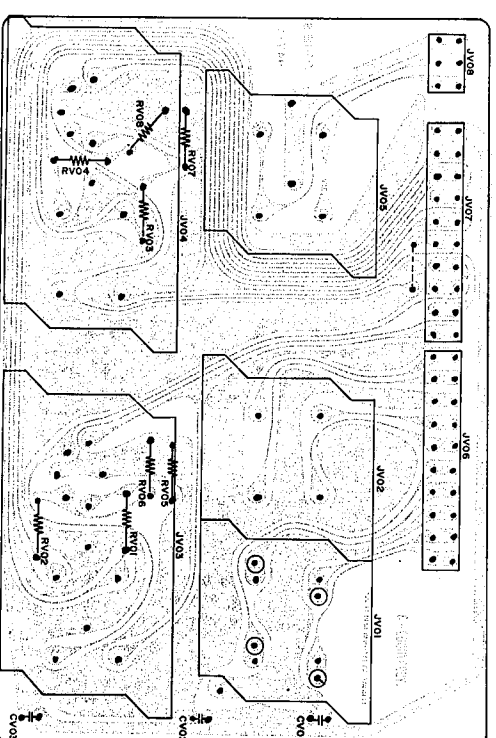
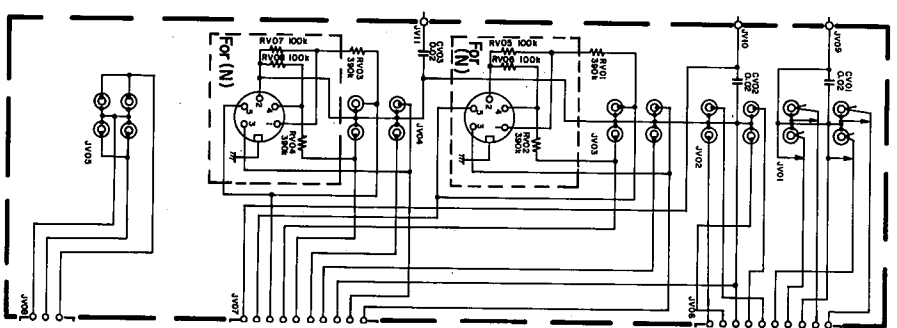

8.4 Fuse Assembly (PP01) Schematic Diagram and Component Locations

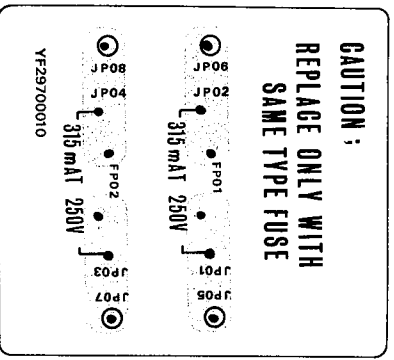
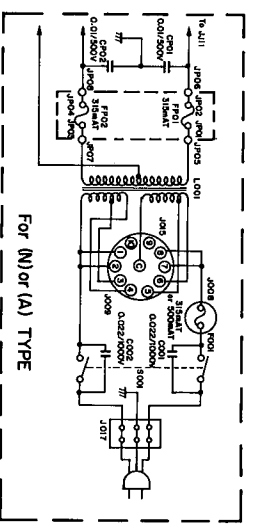

10. PACKING MATERIAL EXPLODED VIEW

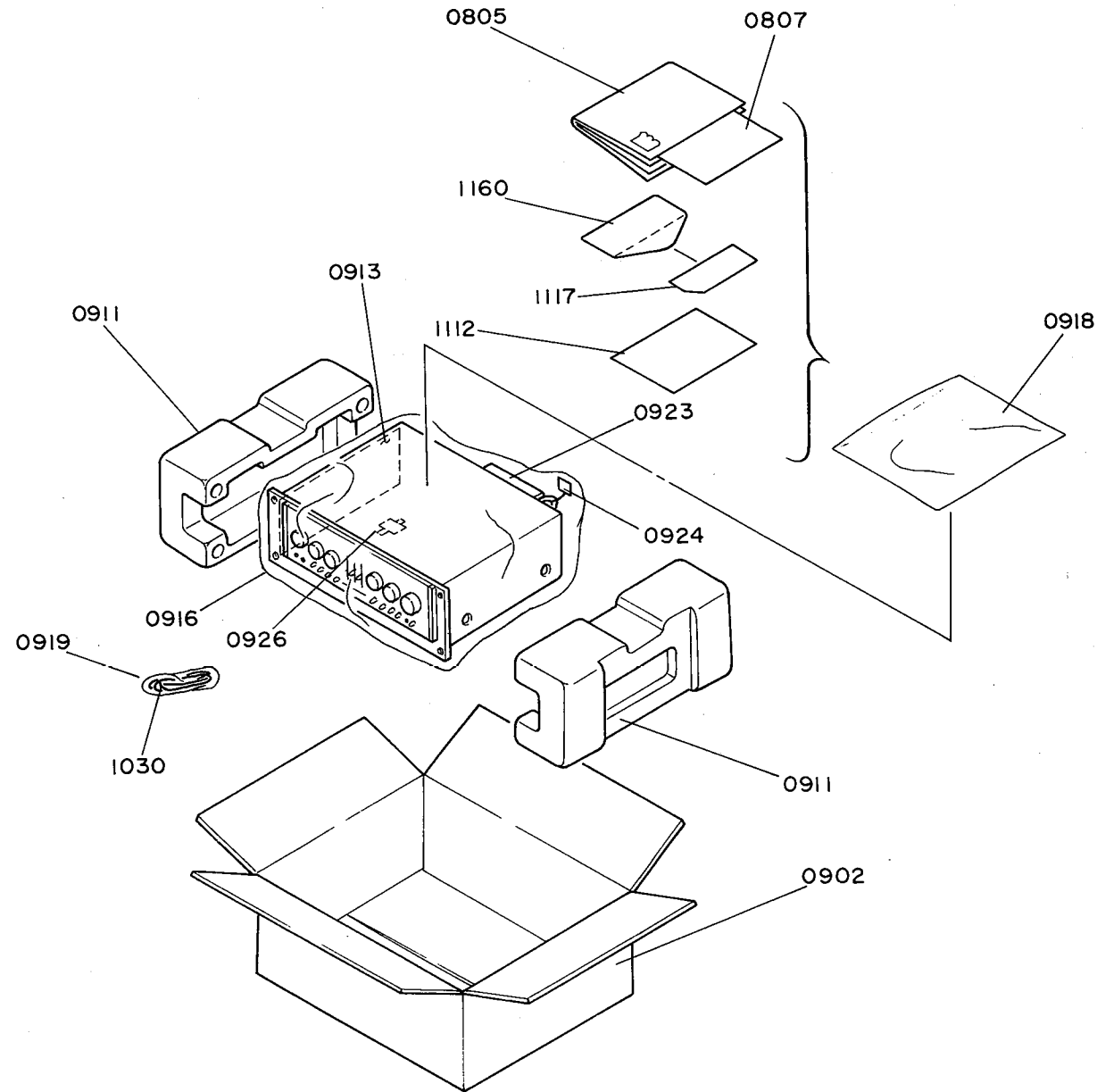

11. PARTS LIST

• (U) for U.S.A.
• (C) for Canada
• (N) for Europe

REF. DESIG.	Q'TY			PART NO.	DESCRIPTION	REF. DESIG.	Q'TY			PART NO.	DESCRIPTION
	U	C	N				U	C	N		
A	1	1	1	2464063400	Front Panel Assembly	0204	3	3	3	51280410U0	B.H. Tapped Screw, B4 x 10
0502	1	1	1	2464063010	Escutcheon Main	0205	2	2	2	51290308B0	B.H. Tapped Screw, B3 x 8
0503	1	1	1	2464063020	Escutcheon Sub	0206	2	2	2	54050300R0	T.L. Washer, OR
0504	1	1	1	2926259040	Bushing	0207	4	4	4	2932057010	Leg
0505	3	3	3	2970259010	Bushing	0208	4	4	4	51570410S0	P. Tapped Screw, P4 x 10
0506	3	3	3	2978259020	Bushing	0214	2	2	2	2979005010	Clamper
0507	9	9	9	2978259012	Bushing	0215	2	2	2	51100408S9	B.H.M. Screw, B4 x 8
0508	1	1	1	2970303010	Mask	0218	1	1	1	62030049W0	Lug
0509	1	1	1	2926303020	Mask	0219	1	1	1	51100306S9	B.H.M. Screw, B3 x 6
0510	1	1	1	2979259022	Bushing	0220	1	1	1	53110303B9	Hexagon Nut
0511	2	2	2	2965063050	Escutcheon	0221	1	1	1	1382005030	Clamper
0513	1	1	1	64020600Q0	R.G. Ring	0223	1	1	1	2464160010	Bracket
0526	10	10	10	51480306A9	F. Washer Screw, F3 x 6	0224	2	2	2	51100306S9	B.H.M. Screw, B3 x 6
						0225	2	2	2	51280306B0	B.H. Tapped Screw, B3 x 6
						0229	1	1	1	2970160040	Bracket
						0230	2	2	2	51100306S9	B.H.M. Screw, B3 x 6
						0231	1	1	1	2965005010	Clamper
						0232	1	1	1	2886005020	Clamper
						0302	1	1	1	2464160210	Bracket
						0303			1	2464160223	Bracket
						0306	2	2	2	51290308B0	B.H. Tapped Screw, B3 x 8
						0307	2	2	2	51280306U0	B.H. Tapped Screw, B3 x 6
						0308	3	3	3	51280306U0	B.H. Tapped Screw, B3 x 6
						0310	6	6	6	51280308U0	B.H. Tapped Screw, B3 x 8
						0311	10	10	10	51280308U0	B.H. Tapped Screw, B3 x 8
						0317	1	1	1	1455259070	Bushing
						0318	1	1	1	62040029W0	Lug
						0325			1	2854160030	Bracket
						0326			1	2970005010	Clamper
						0327	2			51100306A9	B.H.M. Screw, B3 x 6
						0328	2			51100314S9	B.H.M. Screw, B3 x 14
						0329	1			62030039W0	Lug
						0330	1			53110303A9	Hexagon Nut
						0331	2			51100308S9	B.H.M. Screw, B3 x 8
						0332	2			2912259020	Bushing
						0333	1			51100306S9	B.H.M. Screw, B3 x 6
						0334	1			2882861020	Label
						0335	1			62030039W0	Lug
						0336	1			2970120040	Insulator
						0402	1	1	1	2970109020	Shield
						0407	2	2	2	2963267020	Heatsink
						0408	2	2	2	51280306B0	B.H. Tapped Screw, B3 x 6
						0417	1	1	1	2970257112	Lid
						0418	4	4	4	51280306U0	B.H. Tapped Screw, B3 x 6
						0419	4	4	4	51480406S9	F. Washer Screw, F4 x 6
						0420	4	4	4	2965118010	Spacer
						0421	6	6	6	2991259010	Bushing
						0490	1	1	1	2886005020	Clamper
						0500	1	1	1	2464053010	Cover
						0502	1	1	1	2464063010	Escutcheon
						0503	1	1	1	2464063023	Escutcheon
						0504	1	1	1	2926259040	Bushing
						0505	3	3	3	2970259010	Bushing
						0506	3	3	3	2978259020	Bushing
						0507	9	9	9	2978259010	Bushing
						0508	1	1	1	2970303010	Mask
						0509	1	1	1	2926303020	Mask
PF11	3	3	3	75061251P0	Jumper						
PJ08	30	30	30	2933118020	Spacer						
PJ11	35	35	35	75061251P0	Jumper						
PJ12	1	1	1	75060751P0	Jumper						
PJ13	1	1	1	75061001P0	Jumper						
PJ14	1	1	1	75061501P0	Jumper						
PS12	9	9	9	75061251P0	Jumper						
PV11	1	1	1	75061001P0	Jumper						
PW07	8	8	8	3444118050	Spacer						
0102	1	1	1	2970160015	Bracket						
0104	1	1	1	2970120010	Insulator						
0105	3	3	3	51340306B0	F.H. Tapped Screw, F3 x 6						
0106	2	2	2	51100306A9	B.H.M. Screw, B3 x 6						
0107	2	2	2	51100306A9	B.H.M. Screw, B3 x 6						
0108	2	2	2	51100306A9	B.H.M. Screw, B3 x 6						
0109	2	2	2	51100306A9	B.H.M. Screw, B3 x 6						
0110	2	2	2	51100306A9	B.H.M. Screw, B3 x 6						
0111	1	1	1	2970120020	Insulator						
0112	2	2	2	51340306B0	F.H. Tapped Screw, F3 x 6						
0113	2	2	2	51100306A9	B.H.M. Screw, B3 x 6						
0114	2	2	2	51040306B9	F.H.M. Screw, F3 x 6						
0115	3	3	3	2970112510	Shaft						
0116	3	3	3	2970112013	Shaft						
0117	3	3	3	2970106013	Sustainer						
0118	3	3	3	64000400R0	R.G. Ring, E						
0119	6	6	6	51280308B0	B.H. Tapped Screw, B3 x 8						
0120	3	3	3	64054800R0	R.G. Ring, CT						
0121	1	1	1	51280306B0	B.H. Tapped Screw, B3 x 6						
0122	1	1	1	2978259060	Bushing						
0123	3	3	3	51100306A9	B.H.M. Screw, B3 x 6						
0124	1	1	1	2970101010	Support						
0126	1	1	1	2970109010	Shield						
0127	2	2	2	51100306A9	B.H.M. Screw, B3 x 6						
0130	3	3	3	2963125010	Joint						
0202	1	1	1	2970105016	Chassis						

- (U) for U.S.A.
- (C) for Canada
- (N) for Europe

REF. DESIG.	Q'TY			PART NO.	DESCRIPTION	REF. DESIG.	Q'TY			PART NO.	DESCRIPTION
	U	C	N				U	C	N		
0510	1	1	1	2464160110	Bracket	1121			2	55060305S0	T.R. Rivet
0510	1	1	1	2979259020	Bushing	1121	1			9650000050	S. Station Card
0511	2	2	2	51280408B0	B.H. Tapped Screw, B4 x 8	1122			2	54050300R0	T.L. Washer, OR
0512	2	2	2	51470408A9	L. Washer Screw, L4 x 8	1125	1			2818854024	Guarantee Card
0513	1	1	1	64020600Q0	R.G. Ring, CS	1125			1	2970861010	Label
0516	1	1	1	2970154010	Knob	1126			1	2818854040	Guarantee Card
0518	3	3	3	2970154024	Knob	1126			1	54050400A0	T.L. Washer, OR
0520	4	4	4	2970154050	Knob	1135	1			2225813010	Envelope
0522	1	1	1	2963154010	Knob	CE01	1	1	1	EE22505040	Electrolytic Cap., 2.2μF 50V
0523	1	1	1	2963154040	Knob	CE02	1	1	1	EE22505040	Electrolytic Cap., 2.2μF 50V
0524	9	9	9	2963154030	Knob	CE03	1	1	1	DF16474510	Film Cap., 0.47μF ±10% 100V
0525	2	2	2	51690306Q9	Socket Screw, HP	CE04	1	1	1	DF16474510	Film Cap., 0.47μF ±10% 100V
0526	6	6	6	51480306A9	F. Washer Screw, F3 x 6	CE05	1	1	1	EE47601040	Electrolytic Cap., 47μF 10V
0527	1	1	1	51302608B0	P.H. Tapped Screw, P2.6 x 8	CE06	1	1	1	EE47601040	Electrolytic Cap., 47μF 10V
0528	1	1	1	53118179A0	Hexagon Nut	CE07	1	1	1	DD11050010	Ceramic Cap., 5pF 25V SL
0530	6	6	6	51280406U0	B.H. Tapped Screw, B4 x 6	CE08	1	1	1	DD11050010	Ceramic Cap., 5pF 25V SL
0533	4	4	4	52017069J0	H. Head Bolt	CE09	1	1	1	DD11050010	Ceramic Cap., 5pF 25V SL
0535	4	4	4	59030805P1	Washer	CE10	1	1	1	DD11050010	Ceramic Cap., 5pF 25V SL
0560			2	3926120010	Insulator	CE11	1	1	1	EA10701090	Electrolytic Cap., 100μF 10V
0702	1			2464265010	Indicator	CE12	1	1	1	EA10701090	Electrolytic Cap., 100μF 10V
0703		1		2464265020	Indicator	CE13	1	1	1	EE10605040	Electrolytic Cap., 10μF 50V
0704		1		2464265030	Indicator	CE14	1	1	1	EE10605040	Electrolytic Cap., 10μF 50V
0710	2	2	2	51760306B0	OS Tapped Screw, O3 x 6	CE15	1	1	1	DF16474510	Film Cap., 0.47μF ±10% 100V
0714		1		2911861110	Label	CE16	1	1	1	DF16474510	Film Cap., 0.47μF ±10% 100V
0715		1		2911861143	Label	CE17	1	1	1	DD15200010	Ceramic Cap., 20pF ±5% 50V CH
0717	1		1	2578861010	Label	CE18	1	1	1	DD15200010	Ceramic Cap., 20pF ±5% 50V CH
0718	1		1	2932861010	Label	CE19	1	1	1	DD11050010	Ceramic Cap., 5pF 25V SL
0723	1		1	9511101040	Label	CE20	1	1	1	DD11050010	Ceramic Cap., 5pF 25V SL
0724		1		2457861040	Label	CE21	1	1	1	EE33505040	Electrolytic Cap., 3.3μF 50V
0727		1		2911861230	Label	CE22	1	1	1	EE33505040	Electrolytic Cap., 3.3μF 50V
0804	1			2464851010	Instructions	CE23	1	1	1	EA10703590	Electrolytic Cap., 100μF 35V
0805		1	1	2464851312	Instructions	CE24	1	1	1	EA10703590	Electrolytic Cap., 100μF 35V
0806	1			2464851020	Instructions	QE01	1	1	1	HT109412A0	Transistor, 2SA941 GR or BL
0807		1		2464851030	Instructions	QE02	1	1	1	HT109412A0	Transistor, 2SA941 GR or BL
0808		1		2464851050	Instructions	QE03	1	1	1	HT109412A0	Transistor, 2SA941 GR or BL
0809		1		2886851100	Instructions	QE04	1	1	1	HT109412A0	Transistor, 2SA941 GR or BL
0902	1		1	2464801010	Packing Case	QE05	1	1	1	HT320882A0	Transistor, 2SC2088 BL or V
0902		1		2464801150	Packing Case	QE06	1	1	1	HT320882A0	Transistor, 2SC2088 BL or V
0911	2	2	2	2970809010	Cushion	QE07	1	1	1	HT109412A0	Transistor, 2SA941 GR or BL
0913	1	1	1	2918107160	Sheet	QE08	1	1	1	HT109412A0	Transistor, 2SA941 GR or BL
0916	1	1	1	9014550180	Polyethylene Bag	QE09	1	1	1	HT109412A0	Transistor, 2SA941 GR or BL
0918	1	1	1	9013025010	Polyethylene Bag	QE10	1	1	1	HT109412A0	Transistor, 2SA941 GR or BL
0919	1	1	1	9011325010	Polyethylene Bag	QE11	1	1	1	HT320882A0	Transistor, 2SC2088 BL or V
0923	1	1	1	2864804010	Sleeve	QE12	1	1	1	HT320882A0	Transistor, 2SC2088 BL or V
0924		1		9560000043	Hang Tag	RE01	1	1	1	RT05105140	Resistor, 1MΩ ±5% ¼W
0926		1		2731821010	Silicagel	RE02	1	1	1	RT05105140	Resistor, 1MΩ ±5% ¼W
1002	3			9526019010	Serial No. Card	RE03	1	1	1	RT05102140	Resistor, 1kΩ ±5% ¼W
1003		3		9526019020	Serial No. Card	RE04	1	1	1	RT05102140	Resistor, 1kΩ ±5% ¼W
1004		3		9526019060	Serial No. Card	RE05	1	1	1	RT05223140	Resistor, 22kΩ ±5% ¼W
1014		2		9510901020	Label	RE06	1	1	1	RT05223140	Resistor, 22kΩ ±5% ¼W
1030	1	1	1	ZD01500160	Connective Cord	RE07	1	1	1	RT05823140	Resistor, 82kΩ ±5% ¼W
1105		1		2918813010	Envelope	RE08	1	1	1	RT05823140	Resistor, 82kΩ ±5% ¼W
1106		1		2818813010	Envelope	RE09	1	1	1	RT02153140	Resistor, 15kΩ ±2% ¼W
1117		1		9630000180	Guarantee Card	RE10	1	1	1	RT02153140	Resistor, 15kΩ ±2% ¼W
1118		1		2821259010	Bushing	RE11	1	1	1	RT02124140	Resistor, 120kΩ ±2% ¼W
1119		2		53110303A9	Hexagon Nut	RE12	1	1	1	RT02124140	Resistor, 120kΩ ±2% ¼W
1120		2		51060312A9	P.H.M. Screw P3 x 12	RE13	1	1	1	RT05392140	Resistor, 3.9kΩ ±5% ¼W

• (U) for U.S.A.
 • (C) for Canada
 • (N) for Europe

REF. DESIG.	Q'TY			PART NO.	DESCRIPTION
	U	C	N		
RE14	1	1	1	RT05392140	Resistor, 3.9kΩ ±5% ¼W
RE15	1	1	1	RT05471140	Resistor, 470Ω ±5% ¼W
RE16	1	1	1	RT05471140	Resistor, 470Ω ±5% ¼W
RE17	1	1	1	RT05474140	Resistor, 470kΩ ±5% ¼W
RE18	1	1	1	RT05474140	Resistor, 470kΩ ±5% ¼W
RE19	1	1	1	RT05102140	Resistor, 1kΩ ±5% ¼W
RE20	1	1	1	RT05102140	Resistor, 1kΩ ±5% ¼W
RE21	1	1	1	RT05105140	Resistor, 1MΩ ±5% ¼W
RE22	1	1	1	RT05105140	Resistor, 1MΩ ±5% ¼W
RE23	1	1	1	RT05154140	Resistor, 150kΩ ±5% ¼W
RE24	1	1	1	RT05154140	Resistor, 150kΩ ±5% ¼W
RE25	1	1	1	RT05123140	Resistor, 12kΩ ±5% ¼W
RE26	1	1	1	RT05123140	Resistor, 12kΩ ±5% ¼W
RE27	1	1	1	RT05472140	Resistor, 4.7kΩ ±5% ¼W
RE28	1	1	1	RT05472140	Resistor, 4.7kΩ ±5% ¼W
RE29	1	1	1	RT05330140	Resistor, 33Ω ±5% ¼W
RE30	1	1	1	RT05330140	Resistor, 33Ω ±5% ¼W
RE31	1	1	1	RT05474140	Resistor, 470kΩ ±5% ¼W
RE32	1	1	1	RT05474140	Resistor, 470kΩ ±5% ¼W
RE33	1	1	1	GJ05561010	Resistor, 560Ω ±5% 1W
RE34	1	1	1	GJ05561010	Resistor, 560Ω ±5% 1W
CF01	1	1	1	DF15563010	Film Cap., 0.056μF ±5% 50V
CF02	1	1	1	DF15563010	Film Cap., 0.056μF ±5% 50V
CF03	1	1	1	DF15102010	Film Cap., 1000pF ±5% 50V
CF04	1	1	1	DF15102010	Film Cap., 1000pF ±5% 50V
JF01	1	1	1	YP06001040	Plug, 3P Base Post
PF01 LOUDNESS CONTROL BOARD					
PF01	1	1	1	YF29700020	P.W. Board
	1	1	1	ZZ29701020	P.W. Board Assembly
RF01	1	1	1	RT05682140	Resistor, 6.8kΩ ±5% ¼W
RF02	1	1	1	RT05682140	Resistor, 6.8kΩ ±5% ¼W
RF03	1	1	1	RT05823140	Resistor, 82kΩ ±5% ¼W
RF04	1	1	1	RT05823140	Resistor, 82kΩ ±5% ¼W
RF05	1	1	1	RG01040060	Variable Resistor, 100kΩ A 250kΩ C
RF06	1	1	1	RM01040180	Variable Resistor, 100kΩ B
CH01	1	1	1	DF15104010	Film Cap., 0.1μF ±5% 50V
CH02	1	1	1	DF15104010	Film Cap., 0.1μF ±5% 50V
CH03	1	1	1	DF15104010	Film Cap., 0.1μF ±5% 50V
CH04	1	1	1	DF15104010	Film Cap., 0.1μF ±5% 50V
CH05	1	1	1	DF15104010	Film Cap., 0.1μF ±5% 50V
CH06	1	1	1	DF15104010	Film Cap., 0.1μF ±5% 50V
CH07	1	1	1	DF15152010	Film Cap., 1500pF ±5% 50V
CH08	1	1	1	DF15152010	Film Cap., 1500pF ±5% 50V
CH09	1	1	1	DF15222010	Film Cap., 2200pF ±5% 50V
CH10	1	1	1	DF15222010	Film Cap., 2200pF ±5% 50V
CH11	1	1	1	DF65391010	Film Cap., 390pF ±5% 50V
CH12	1	1	1	DF65391010	Film Cap., 390pF ±5% 50V
CH13	1	1	1	DF17224010	Film Cap., 0.22μF ±10% 35V
CH14	1	1	1	DF17224010	Film Cap., 0.22μF ±10% 35V
CH15	1	1	1	DD11050010	Ceramic Cap., 5pF 25V SL
CH16	1	1	1	DD11050010	Ceramic Cap., 5pF 25V SL
CH17	1	1	1	EE10605040	Electrolytic Cap., 10μF 50V
CH18	1	1	1	EE10605040	Electrolytic Cap., 10μF 50V
CH19	1	1	1	DD15101020	Ceramic Cap., 100pF 50V ±5% TH
CH20	1	1	1	DD15101020	Ceramic Cap., 100pF 50V ±5% TH
CH21	1	1	1	EA47603590	Electrolytic Cap., 47μF 35V

REF. DESIG.	Q'TY			PART NO.	DESCRIPTION
	U	C	N		
CH22	1	1	1	EA47603590	Electrolytic Cap., 47μF 35V
QH01	1	1	1	HT320882A0	Transistor, 2SC2088 BL or V
QH02	1	1	1	HT320882A0	Transistor, 2SC2088 BL or V
QH03	1	1	1	HT320882A0	Transistor, 2SC2088 BL or V
QH04	1	1	1	HT320882A0	Transistor, 2SC2088 BL or V
QH05	1	1	1	HT109412A0	Transistor, 2SA941 GR or BL
QH06	1	1	1	HT109412A0	Transistor, 2SA941 GR or BL
RH01	1	1	1	RT05334140	Resistor, 330kΩ ±5% ¼W
RH02	1	1	1	RT05334140	Resistor, 330kΩ ±5% ¼W
RH03	1	1	1	RT05244140	Resistor, 240kΩ ±5% ¼W
RH04	1	1	1	RT05244140	Resistor, 240kΩ ±5% ¼W
RH05	1	1	1	RT05513140	Resistor, 51kΩ ±5% ¼W
RH06	1	1	1	RT05513140	Resistor, 51kΩ ±5% ¼W
RH07	1	1	1	RT05113140	Resistor, 11kΩ ±5% ¼W
RH08	1	1	1	RT05113140	Resistor, 11kΩ ±5% ¼W
RH09	1	1	1	RT05113140	Resistor, 11kΩ ±5% ¼W
RH10	1	1	1	RT05113140	Resistor, 11kΩ ±5% ¼W
RH11	1	1	1	RT05113140	Resistor, 11kΩ ±5% ¼W
RH12	1	1	1	RT05113140	Resistor, 11kΩ ±5% ¼W
RH13	1	1	1	RT05115140	Resistor, 1.1MΩ ±5% ¼W
RH14	1	1	1	RT05115140	Resistor, 1.1MΩ ±5% ¼W
RH15	1	1	1	RT05102140	Resistor, 1kΩ ±5% ¼W
RH16	1	1	1	RT05102140	Resistor, 1kΩ ±5% ¼W
RH17	1	1	1	RT05103140	Resistor, 10kΩ ±5% ¼W
RH18	1	1	1	RT05103140	Resistor, 10kΩ ±5% ¼W
RH19	1	1	1	RT05682140	Resistor, 6.8kΩ ±5% ¼W
RH20	1	1	1	RT05682140	Resistor, 6.8kΩ ±5% ¼W
RH21	1	1	1	RT05102140	Resistor, 1kΩ ±5% ¼W
RH22	1	1	1	RT05102140	Resistor, 1kΩ ±5% ¼W
RH23	1	1	1	RT05104140	Resistor, 100kΩ ±5% ¼W
RH24	1	1	1	RT05104140	Resistor, 100kΩ ±5% ¼W
RH25	1	1	1	RT05221140	Resistor, 220Ω ±5% ¼W
RH26	1	1	1	RT05221140	Resistor, 220Ω ±5% ¼W
RH27	1	1	1	GF05182120	Resistor, 1.8kΩ ±5% ½W
RH28	1	1	1	GF05182120	Resistor, 1.8kΩ ±5% ½W
RH29	1	1	1	RT05103140	Resistor, 10kΩ ±5% ¼W
RH30	1	1	1	RT05103140	Resistor, 10kΩ ±5% ¼W
RH31	1	1	1	RT05124140	Resistor, 120kΩ ±5% ¼W
RH32	1	1	1	RT05124140	Resistor, 120kΩ ±5% ¼W
JJ01	1	1	1	YP06000400	Plug, 10P
JJ02	1	1	1	YP06000400	Plug, 10P
JJ03	1	1	1	YP06000330	Plug, 3P
JJ04	1	1	1	YP06000400	Plug, 10p
JJ05	1	1	1	YP06000370	Plug, 7P
JJ06	1	1	1	YP06000340	Plug, 4P
JJ07	1	1	1	YP06001050	Plug, 5P Base Post
JJ08	1	1	1	YP10001130	Plug
JJ09	1	1	1	YP10001130	Plug
JJ10	1	1	1	YP10001130	Plug
JJ11	1	1	1	YP10001140	Plug, Wrapping Pin
JJ12	1	1	1	YP10001140	Plug, Wrapping Pin
JJ13	1	1	1	YP10001130	Plug, Wrapping Pin
JJ14	1	1	1	YP10001130	Plug
JJ15	1	1	1	YP10001130	Plug
JJ16	1	1	1	YP10001130	Plug
JJ17	1	1	1	YP10001130	Plug
JJ18	1	1	1	YP10001140	Plug, Wrapping Pin

- (U) for U.S.A.
- (C) for Canada
- (N) for Europe

REF. DESIG.	Q'TY			PART NO.	DESCRIPTION
	U	C	N		
JJ19 ? JJ26 JJ27 ? JJ33	8	8	8	YP10001130	Plug
PJ01	1	1	1	YG24640010 ZZ24640010	P.W. Board P.W. Board Assembly
SJ01 SJ02 SJ03 CN01 CN02 LN01 QN01 QN02 QN03 QN04	1	1	1	SR09050110 SR04030190 SR04030190 EA10701090 EA10605090 LY20240120 HT105642H0 HT308282H0 HD20011010 HD30023090	Rotary Switch, Selector Rotary Switch, Tape Copy Rotary Switch, Tape Monitor Electrolytic Cap., 100μF 10V Electrolytic Cap., 10μF 50V Relay, 24V Transistor, 2SA564A Q or R Transistor, 2SC828A Q or R Diode, W06C Zener, WZ071
QN05 QN06 QN07 RN01 RN02 RN03 RN04 RN05 RN06 RN07	1	1	1	HD20011010 HD20003210 HD20011010 GJ05821010 RT05103140 RT05154140 RT05104140 RT05753140 RT05103140 GF05472120	Diode, W06C Diode, 1S2471 Diode, W06C Resistor, 820Ω ±5% 1W Resistor, 10kΩ ±5% ¼W Resistor, 150kΩ ±5% ¼W Resistor, 100kΩ ±5% ¼W Resistor, 75kΩ ±5% ¼W Resistor, 10kΩ ±5% ¼W Resistor, 4.7kΩ ±5% ¼W
RN08 RN09 RN10 CP01 CP02 FP01 FP02 JP01 ? JP04 JP05 ? JP08	1	1	1	GF05222120 RT05474140 RT05474140 DK18103510 DK18103510 FS10031800 FS10031800 YJ08000200 YP10001130	Resistor, 2.2kΩ ±5% ¼W Resistor, 470kΩ ±5% ¼W Resistor, 470kΩ ±5% ¼W Ceramic Cap., 0.01μF 500V Ceramic Cap., 0.01μF 500V Fuse, 315 MA Fuse, 315 MA Jack Plug
PP01	1	1	1	YF29700010 ZZ29708010	PP01 FUSE BOARD P.W. Board P.W. Board Assembly
CS05 CS06 CS07 CS08 CS09 CS10 CS11 CS12 CS13 CS14	1	1	1	DF15153010 DF15153010 DF15153010 DF15153010 DF15682010 DF15682010 DF65391010 DF65391010 DF15822010 DF15822010	Film Cap., 0.015μF ±5% 50V Film Cap., 0.015μF ±5% 50V Film Cap., 0.015μF ±5% 50V Film Cap., 0.015μF ±5% 50V Film Cap., 6800pF ±5% 50V Film Cap., 6800pF ±5% 50V Film Cap., 390pF ±5% 50V Film Cap., 390pF ±5% 50V Film Cap., 8200pF ±5% 50V Film Cap., 8200pF ±5% 50V

REF. DESIG.	Q'TY			PART NO.	DESCRIPTION
	U	C	N		
CS15 CS16 CS17 CS18 CS19 CS20 CS21 CS22 CS23 CS24	1	1	1	DD15101020 DD15101020 DF15103010 DF15103010 DF15103010 DF15103010 DF15103010 DF15683010 DF15683010 DF15683010 DF15683010	Ceramic Cap., 100pF ±5% 50V Ceramic Cap., 100pF ±5% 50V Film Cap., 0.01μF ±5% 50V Film Cap., 0.01μF ±5% 50V Film Cap., 0.01μF ±5% 50V Film Cap., 0.01μF ±5% 50V Film Cap., 0.01μF ±5% 50V Film Cap., 0.068μF ±5% 50V Film Cap., 0.068μF ±5% 50V Film Cap., 0.068μF ±5% 50V Film Cap., 0.068μF ±5% 50V
CS25 CS26 JS01 JS02 JS03 JS04 JS05 JS06 JS07	1	1	1	DF15182010 DF15182010 YJ06000400 YJ06000370 YJ06000370 YP06001090 YP10001130 YP10001130 YP10001130	Film Cap., 1800pF ±5% 50V Film Cap., 1800pF ±5% 50V Jack, 10P Socket Jack, 7P Socket Jack, 7P Socket Plug, 3P Base Post 20mm Plug Plug Plug
PS01	1	1	1	YG27700010 ZZ29700010	PS01 TONE CONTROL, FILTER BOARD P.W. Board P.W. Board Assembly
RS01 RS02 RS07 RS11 RS12 RS13 RS14 RS15 RS16 RS17	1	1	1	RT05102140 RT05102140 RS01040060 RT05183140 RT05183140 RT05183140 RT05183140 RT05183140 RT05562140 RT05562140 RT05562140	Resistor, 1kΩ ±5% ¼W Resistor, 1kΩ ±5% ¼W Variable Resistor, 100kΩ MN Balance Resistor, 18kΩ ±5% ¼W Resistor, 18kΩ ±5% ¼W Resistor, 18kΩ ±5% ¼W Resistor, 18kΩ ±5% ¼W Resistor, 18kΩ ±5% ¼W Resistor, 5.6kΩ ±5% ¼W Resistor, 5.6kΩ ±5% ¼W Resistor, 5.6kΩ ±5% ¼W
RS18 RS19 RS20 RS21 RS22 RS23 RS24 RS25 RS26 RS27	1	1	1	RT05562140 RT05562140 RT05562140 RT05562140 RT05562140 RT05273140 RT05273140 RT05273140 RT05273140 RT05273140 RT05392140	Resistor, 5.6kΩ ±5% ¼W Resistor, 5.6kΩ ±5% ¼W Resistor, 5.6kΩ ±5% ¼W Resistor, 5.6kΩ ±5% ¼W Resistor, 5.6kΩ ±5% ¼W Resistor, 27kΩ ±5% ¼W Resistor, 27kΩ ±5% ¼W Resistor, 27kΩ ±5% ¼W Resistor, 27kΩ ±5% ¼W Resistor, 27kΩ ±5% ¼W Resistor, 3.9kΩ ±5% ¼W
RS28 RS29 RS30 RS31 RS32 RS33 RS35 RS36 RS37 RS38	1	1	1	RT05392140 RT05274140 RT05274140 RS01040040 RS01040040 RS01040040 RT05100140 RT05100140 RT05684140 RT05684140	Resistor, 3.9kΩ ±5% ¼W Resistor, 270kΩ ±5% ¼W Resistor, 270kΩ ±5% ¼W Variable Resistor, 100kΩ B (Bass) Variable Resistor, 100kΩ B (Mid) Variable Resistor, 100kΩ B (Treble) Resistor, 10Ω ±5% ¼W Resistor, 10Ω ±5% ¼W Resistor, 680kΩ ±5% ¼W Resistor, 680kΩ ±5% ¼W
RS39 RS40 RS41 RS42	1	1	1	RT05684140 RT05684140 RT05105140 RT05105140	Resistor, 680kΩ ±5% ¼W Resistor, 680kΩ ±5% ¼W Resistor, 1MΩ ±5% ¼W Resistor, 1MΩ ±5% ¼W

• (U) for U.S.A.
 • (C) for Canada
 • (N) for Europe

REF. DESIG.	Q'TY			PART NO.	DESCRIPTION
	U	C	N		
RS43	1	1	1	RT05182140	Resistor, 1.8kΩ ±5% ¼W
RS44	1	1	1	RT05182140	Resistor, 1.8kΩ ±5% ¼W
RS45	1	1	1	RT05153140	Resistor, 15kΩ ±5% ¼W
RS46	1	1	1	RT05153140	Resistor, 15kΩ ±5% ¼W
RS47	1	1	1	RT05100140	Resistor, 10Ω ±5% ¼W
RS48	1	1	1	RT05100140	Resistor, 10Ω ±5% ¼W
SS01	1	1	1	SR04050100	Rotary Switch, Mode Switch
SS02	1	1	1	SP04040170	Pushswitch, Tone, Mode, Def. Muting
SS03	1	1	1	SP04010210	Pushswitch, Low Filter
SS04	1	1	1	SP04010210	Pushswitch, Hi Filter
CV01	1	1	1	DK18203010	Ceramic Cap., 0.02μF 50V
CV02	1	1	1	DK18203010	Ceramic Cap., 0.1μF 50V
CV03	1	1	1	DK18203010	Ceramic Cap., 0.1μF 50V
CV04	1	1	1	DF17104010	Film Cap., 0.1μF 50V
JV01	1	1	1	YT02040270	Terminal, Phono 1, 2, 4P
JV02	1	1	1	YT02040150	Terminal, Tuner, Aux 4P
JV03	1	1	1	BY01050060	Jack, 4P + Din Terminal for Tape 1
JV03	1	1	1	YT02040150	Terminal, Tape 1 4P
JV04	1	1	1	BY01050060	Jack, 4P + Din Terminal for Tape 2
JV04	1	1	1	YT02040150	Terminal, Tape 2 4P
JV05	1	1	1	YT02040150	Terminal, Pre Out 1, 2 4P
JV06	1	1	1	YJ06000400	Jack, 10P Socket
JV07	1	1	1	YJ06000400	Jack, 10P Socket
JV08	1	1	1	YJ06000330	Jack, 3P Socket
JV09	1	1	1	YP10001130	Plug
JV10	1	1	1	YP10001130	Plug
JV11	1	1	1	YP10001130	Plug
PV01 INPUT TERMINAL BOARD					
PV01	1	1	1	YD29700022	P.W. Board
	1	1	1	ZZ29700020	P.W. Board Assembly
			1	ZZ29708020	P.W. Board Assembly
RV01		1		RT05394140	Resistor, 390kΩ ±5% ¼W
RV02		1		RT05394140	Resistor, 390kΩ ±5% ¼W
RV03		1		RT05394140	Resistor, 390kΩ ±5% ¼W
RV04		1		RT05394140	Resistor, 390kΩ ±5% ¼W
RV05		1		RT05104140	Resistor, 100kΩ ±5% ¼W
RV06		1		RT05104140	Resistor, 100kΩ ±5% ¼W
RV07		1		RT05104140	Resistor, 100kΩ ±5% ¼W
RV08		1		RT05104140	Resistor, 100kΩ ±5% ¼W
JW01	1	1	1	YJ01000860	Jack, Headphones
PW01 SPKR/HEADPHONE BOARD					
PW01	1	1	1	YD29700030	P.W. Board
	1	1	1	ZZ29700030	P.W. Board Assembly
RW01	1	1	1	GJ05331020	Resistor, 330Ω ±5% 2W
RW02	1	1	1	GJ05331020	Resistor, 330Ω ±5% 2W
RW03	1	1	1	GJ05151010	Resistor, 150Ω ±5% 1W
RW04	1	1	1	GJ05151010	Resistor, 150Ω ±5% 1W
SW01	1	1	1	SP02020240	Pushswitch, SPKR
C001		1		BF33300020	Cap. Comp., 0.033μF + 120Ω
C001		1		DF17223800	Film Cap., 0.022μF ±10% 1000V
C002		1		DF17223800	Film Cap., 0.022μF ±10% 1000V
F001		1		FS10031800	Fuse, 315 MA
F001	1	1		FS10050090	Fuse, 0.5A 250V UL
G001	1			BF33300030	Cap. Comp., 0.033μF + 120Ω 125V
J001	1	1	1	YJ01000850	Jack, Mic

REF. DESIG.	Q'TY			PART NO.	DESCRIPTION
	U	C	N		
J002	1	1	1	YJ01000850	Jack, Mic
J003	1	1	1	YT01010050	Terminal, Ground
J004	1	1	1	YT03040160	Terminal, Spkr (Input)
J005	1	1	1	YT03040160	Terminal, Spkr (System 1)
J006	1	1	1	YT03040160	Terminal, Spkr (System 2)
J007	1	1	1	JY05000250	Jack, L.E.D. Socket with wire
J008			1	YJ08000220	Jack, Fuse Holder
J008	1	1		YJ08000230	Jack, Fuse Holder
J009					
J012		4	4	YJ04000560	Jack, AC Outlet
J015			1	BY03110010	Plug, Voltage Selector
J016	1	1	1	YJ06001050	Jack, 5P Socket for L.E.D. & Trans.
J017	1	1	1	YL09030010	Terminal, 3P Terminal for AC Cord
J017	1	1	1	YU04110010	PF01 + PS01
J018	1	1	1	YJ06001040	Jack, 3P Socket
L001	1	1	1	TS16012020	Power Transformer
L001	1	1	1	TS16012040	Power Transformer
Q001	1	1	1	HI10004030	L.E.D.
S001			1	SP02010250	Pushswitch, Power
S001	1	1		SP02020210	Pushswitch, Power
W001			1	YC01900030	A.C. Power Cord
W001	1	1	1	YC02000160	A.C. Power Cord, SPT-2 125V. 13A
C401	1	1	1	EE47505040	Electrolytic Cap., 4.7μF 50V
C402	1	1	1	EE47505040	Electrolytic Cap., 4.7μF 50V
C403	1	1	1	DF16474510	Film Cap., 0.47μF ±10% 100V
C404	1	1	1	DF16474510	Film Cap., 0.47μF ±10% 100V
C405	1	1	1	DD16680010	Ceramic Cap., 68pF ±10% 50V RH
C406	1	1	1	DD16680010	Ceramic Cap., 68pF ±10% 50V RH
C407	1	1	1	DF15152010	Film Cap., 0.0015μF ±5% 50V
C408	1	1	1	DF15152010	Film Cap., 0.0015μF ±5% 50V
C409	1	1	1	DF74472010	Film Cap., 4700pF ±2% 50V
C410	1	1	1	DF74472010	Film Cap., 4700pF ±2% 50V
C411	1	1	1	DF14122010	Film Cap., 1200pF ±2% 50V
C412	1	1	1	DF14122010	Film Cap., 1200pF ±2% 50V
C413	1	1	1	DD15301010	Ceramic Cap., 300pF ±5% 50V
C414	1	1	1	DD15301010	Ceramic Cap., 300pF ±5% 50V
C415	1	1	1	DD15600010	Ceramic Cap., 60pF ±5% 50V
C416	1	1	1	DD15600010	Ceramic Cap., 60pF ±5% 50V
C417	1	1	1	EE10505040	Electrolytic Cap., 1μF 50V
C418	1	1	1	EE10505040	Electrolytic Cap., 1μF 50V
C419	1	1	1	EE10701640	Electrolytic Cap., 100μF 16V
C420	1	1	1	EE10701640	Electrolytic Cap., 100μF 16V
C421	1	1	1	DD16500010	Ceramic Cap., 50pF ±10% 50V SL
C422	1	1	1	DD16500010	Ceramic Cap., 50pF ±10% 50V SL
C423	1	1	1	EE22505040	Electrolytic Cap., 2.2μF 50V
C424	1	1	1	EE22505040	Electrolytic Cap., 2.2μF 50V
C425	1	1	1	DF16474510	Film Cap., 0.47μF ±10% 100V
C426	1	1	1	DF16474510	Film Cap., 0.47μF ±10% 100V
C427	1	1	1	DD16151010	Ceramic Cap., 150pF ±10% 50V
C428	1	1	1	DD16151010	Ceramic Cap., 150pF ±10% 50V
C429	1	1	1	EA47605090	Electrolytic Cap., 47μF 50V
C430	1	1	1	EA47605090	Electrolytic Cap., 47μF 50V
C431	1	1	1	DF16105500	Film Cap., 1μF ±10% 500V
C432	1	1	1	DF16105500	Film Cap., 1μF ±10% 500V
C451	1	1	1	EE47505040	Electrolytic Cap., 4.7μF 50V
C452	1	1	1	EE47505040	Electrolytic Cap., 4.7μF 50V

- (U) for U.S.A.
- (C) for Canada
- (N) for Europe

REF. DESIG.	Q'TY			PART NO.	DESCRIPTION
	U	C	N		
C453	1	1	1	EA47703590	Electrolytic Cap., 470μF 35V
C454	1	1	1	EA10703590	Electrolytic Cap., 100μF 35V
C455	1	1	1	DF16474510	Film Cap., 0.47μF ±10% 100V
C456	1	1	1	EA47705090	Electrolytic Cap., 470μF 50V
C457	1	1	1	EQ10505010	Electrolytic Cap., 1μF 50V
C458	1	1	1	EQ10505010	Electrolytic Cap., 1μF 50V
Q401	1	1	1	HT109701A0	Transistor, 2SA970 GR
Q402	1	1	1	HT109701A0	Transistor, 2SA970 GR
Q403	1	1	1	HT109701A0	Transistor, 2SA970 GR
Q404	1	1	1	HT109701A0	Transistor, 2SA970 GR
Q405	1	1	1	HT322402A0	Transistor, 2SC2240 GR or BL
Q406	1	1	1	HT322402A0	Transistor, 2SC2240 GR or BL
Q407	1	1	1	HD20003210	Diode, 1S2471
Q408	1	1	1	HD20003210	Diode, 1S2471
Q409	1	1	1	HT322402A0	Transistor, 2SC2240 GR or BL
Q410	1	1	1	HT318852C0	Transistor, 2SC1885 R or S
Q411	1	1	1	HT322402A0	Transistor, 2SC2240 GR or BL
Q412	1	1	1	HT318852C0	Transistor, 2SC1885 R or S
Q451	1	1	1	HF201471A0	F.E.T., 2SK147 GR
Q452	1	1	1	HF201471A0	F.E.T., 2SK147 GR
Q453	1	1	1	HT403302A0	Transistor, 2SD330 D or E
R401	1	1	1	RN05513140	Resistor, 51kΩ ±5% ¼W
R402	1	1	1	RN05513140	Resistor, 51kΩ ±5% ¼W
R403	1	1	1	RN05474140	Resistor, 470kΩ ±5% ¼W
R404	1	1	1	RN05464140	Resistor, 470kΩ ±5% ¼W
R405	1	1	1	RT05331140	Resistor, 330Ω ±5% ¼W
R406	1	1	1	RT05331140	Resistor, 330Ω ±5% ¼W
R411	1	1	1	RN05224140	Resistor, 220kΩ ±5% ¼W
R412	1	1	1	RN05224140	Resistor, 220kΩ ±5% ¼W
R413	1	1	1	RT05682140	Resistor, 6.8kΩ ±5% ¼W
R414	1	1	1	RT05682140	Resistor, 6.8kΩ ±5% ¼W
R415	1	1	1	RT05682140	Resistor, 6.8kΩ ±5% ¼W
R416	1	1	1	RT05682140	Resistor, 6.8kΩ ±5% ¼W
R417	1	1	1	RT05221140	Resistor, 220Ω ±5% ¼W
R418	1	1	1	RT05221140	Resistor, 220Ω ±5% ¼W
R419	1	1	1	RT02513140	Resistor, 51kΩ ±2% ¼W
R420	1	1	1	RT02513140	Resistor, 51kΩ ±2% ¼W
R421	1	1	1	RT05683140	Resistor, 68kΩ ±5% ¼W
R422	1	1	1	RT05683140	Resistor, 68kΩ ±5% ¼W
R423	1	1	1	RT02621140	Resistor, 620Ω ±2% ¼W
R424	1	1	1	RT02621140	Resistor, 620Ω ±2% ¼W
R425	1	1	1	RT02624140	Resistor, 620kΩ ±2% ¼W
R426	1	1	1	RT02624140	Resistor, 620kΩ ±2% ¼W
R427	1	1	1	RT05303140	Resistor, 30kΩ ±5% ¼W
R428	1	1	1	RT05303140	Resistor, 30kΩ ±5% ¼W
R429	1	1	1	GU05562120	Resistor, 5.6kΩ ±5% ¼W
R430	1	1	1	GU05562120	Resistor, 5.6kΩ ±5% ¼W
R431	1	1	1	GF05151140	Resistor, 150Ω ±5% ¼W
R432	1	1	1	GF05151140	Resistor, 150Ω ±5% ¼W
R433	1	1	1	GF05471140	Resistor, 470Ω ±5% ¼W
R434	1	1	1	GF05471140	Resistor, 470Ω ±5% ¼W
R435	1	1	1	RT05474140	Resistor, 470kΩ ±5% ¼W
R436	1	1	1	RT05474140	Resistor, 470kΩ ±5% ¼W
R437	1	1	1	RT05221140	Resistor, 220Ω ±5% ¼W
R438	1	1	1	RT05221140	Resistor, 220Ω ±5% ¼W
R439	1	1	1	GF05560120	Resistor, 56Ω ±5% ¼W
R440	1	1	1	GF05560120	Resistor, 56Ω ±5% ¼W

REF. DESIG.	Q'TY			PART NO.	DESCRIPTION
	U	C	N		
R441	1	1	1	RT05474140	Resistor, 470kΩ ±5% ¼W
R442	1	1	1	RT05474140	Resistor, 470kΩ ±5% ¼W
R451	1	1	1	RT05068140	Resistor, 6.8Ω ±5% ¼W
R452	1	1	1	RT05068140	Resistor, 6.8Ω ±5% ¼W
R453	1	1	1	RT05510140	Resistor, 51Ω ±5% ¼W
R454	1	1	1	RT05510140	Resistor, 51Ω ±5% ¼W
R455	1	1	1	GM21220010	Resistor, 2.00kΩ ±2% ½W
R456	1	1	1	GM21220010	Resistor, 2.00kΩ ±2% ½W
R459	1	1	1	RT05100140	Resistor, 10Ω ±5% ¼W
R460	1	1	1	RT05100140	Resistor, 10Ω ±5% ¼W
R461	1	1	1	RT05222140	Resistor, 2.2kΩ ±5% ¼W
R462	1	1	1	RT05222140	Resistor, 2.2kΩ ±5% ¼W
R463	1	1	1	RN05223140	Resistor, 22kΩ ±5% ¼W
R464	1	1	1	RN05223140	Resistor, 22kΩ ±5% ¼W
R465	1	1	1	RT05471140	Resistor, 470Ω ±5% ¼W
R466	1	1	1	RT05471140	Resistor, 470Ω ±5% ¼W
R467	1	1	1	RT05362140	Resistor, 3.6kΩ ±5% ¼W
R468	1	1	1	RT05392140	Resistor, 3.9kΩ ±5% ¼W
R469	1	1	1	RT05334140	Resistor, 330kΩ ±5% ¼W
R470	1	1	1	RT05334140	Resistor, 330kΩ ±5% ¼W
R471	1	1	1	GF05750140	Resistor, 75Ω ±5% ¼W
C801	1	1	1	EA47706310	Electrolytic Cap., 470μF 63V
C802	1	1	1	EA47706310	Electrolytic Cap., 470μF 63V
C803	1	1	1	EA10701690	Electrolytic Cap., 100μF 16V
C804	1	1	1	EA10701690	Electrolytic Cap., 100μF 16V
C805	1	1	1	DF16102010	Film Cap., 1000pF ±10% 50V
C806	1	1	1	DF16102010	Film Cap., 1000pF ±10% 50V
C807	1	1	1	EA10701690	Electrolytic Cap., 100μF 16V
C808	1	1	1	EA47505090	Electrolytic Cap., 4.7μF 50V
C809	1	1	1	EA47505090	Electrolytic Cap., 4.7μF 50V
C810	1	1	1	EA47605090	Electrolytic Cap., 47μF 50V
C811	1	1	1	EA47605090	Electrolytic Cap., 47μF 50V
C812	1	1	1	DK18103510	Ceramic Cap., 0.01μF 500V YZ
C813	1	1	1	DK18103510	Ceramic Cap., 0.01μF 500V YZ
Q801	1	1	1	HT403132P0	Transistor, 2SD313 Dor E
Q802	1	1	1	HT205072P0	Transistor, 2SB507 D or E
Q803	1	1	1	HT315091Q0	Transistor, 2SC1509 Q
Q804	1	1	1	HT107771Q0	Transistor, 2SA777 Q
Q805	1	1	1	HT315091Q0	Transistor, 2SC1509 Q
Q806	1	1	1	HT107771Q0	Transistor, 2SA777 Q
Q807	1	1	1	HD30023090	Zener, WZ071
Q808	1	1	1	HD20003210	Diode, 1S2471
Q809	1	1	1	HD20013030	Diode, DS133B
Q810	1	1	1	HD20013030	Diode, DS133B
R801	1	1	1	GJ05010010	Resistor, 1Ω ±5% 1W
R802	1	1	1	GJ05010010	Resistor, 1Ω ±5% 1W
R803	1	1	1	RT05822140	Resistor, 8.2kΩ ±5% ¼W
R804	1	1	1	RT05822140	Resistor, 8.2kΩ ±5% ¼W
R805	1	1	1	RT05682140	Resistor, 6.8kΩ ±5% ¼W
R806	1	1	1	RT05682140	Resistor, 6.8kΩ ±5% ¼W
R807	1	1	1	RT05102140	Resistor, 1kΩ ±5% ¼W
R808	1	1	1	RT05102140	Resistor, 1kΩ ±5% ¼W
R809	1	1	1	GF05472120	Resistor, 4.7kΩ ±5% ¼W
R810	1	1	1	RT05122140	Resistor, 1.2kΩ ±5% ¼W
R811	1	1	1	RT05393140	Resistor, 39kΩ ±5% ¼W
R812	1	1	1	RT05393140	Resistor, 39kΩ ±5% ¼W
R813	1	1	1	RT05363140	Resistor, 36kΩ ±5% ¼W
R814	1	1	1	RT05752140	Resistor, 7.5kΩ ±5% ¼W

12. TECHNICAL SPECIFICATIONS

FOR U.S.A. MODEL ONLY

Rated Output Level	3 Volts RMS
Total Harmonic Distortion (THD), 20 Hz to 20 kHz at Rated Output Level	0.01%
Intermodulation (IM) Distortion at Rated Output	0.01%
Phono Section	
Input Overload at 1 kHz (MM)	220 mV
THD (100 mV Input at 1 kHz)	0.01%
Equivalent Input Noise ("A" Weighted)	
Phono (MM)	0.24 μ V
Phono (MC)	0.04 μ V
Dynamic Range ("A" Weighted)	
Phono (MM)	120 dB
Input Sensitivity (ref. Output 1.5 V)	
Phono (MM)	1.8 mV
Phono (MC)	90 μ V
Input Impedance	
Phono (MM)	47 k ohms
Phono (MC)	40 ohms
Input Capacitance	100 pF
Frequency Response, RIAA 20 Hz to 20 kHz	\pm 0.2 dB
Signal to Noise Ratio (ref. to rated output and 7.75 mV input "PHONO MM" or 0.375 mV input "PHONO MC" at 1 kHz, "A" weighted)	
Phono (MM)	90 dB
Phono (MC)	80 dB
High Level Inputs (Aux, Tape, and Tuner)	
Input Sensitivity (ref. Output 1.5 V)	180 mV
Input Impedance	30 k ohms
Frequency Response	
20 Hz ~ 20 kHz	\pm 0.1 dB
5 Hz ~ 60 kHz	\pm 1.0 dB
Signal-to-Noise Ratio (ref. to Rated Output and 775 mV input, "A" weighted)	98 dB
Output Levels	
Tape Out (ref. to 7.75 mV at Phono Inputs)	775 mV
Pre Out (ref. to 180 mV at Aux Inputs)	1.5 V
(ref. to 500 mV at Aux Inputs)	4.2 V
Output Impedance	
Tape Out (Phono Mode)	270 ohms
Pre Out	220 ohms
General	
Power Requirements	120 VAC, 60 Hz
Power Consumption	11 Watts
Dimensions (WxHxD)	16-3/8" x 5-3/4" x 9-3/4" (416mm x 146mm x 247mm)
Weight	
Unit Alone	14.5 lbs (6.6 kg)
Packed for Shipment	17.6 lbs (8.0 kg)

FOR EUROPEAN MODEL ONLY**AUDIO SECTION**

TOTAL HARMONIC DISTORTION AT RATED POWER OUTPUT	0.005%
I.M. DISTORTION AT RATED POWER OUTPUT	
(250 Hz AND 8 kHz MIXED, AMPLITUDE RATIO 4:1)	0.003%
Frequency Response	
Phono (RIAA)	±0.2 dB
Aux (±1 dB)	7 Hz~100 kHz
Signal-to-Noise Ratio (IHF, MC)	
Phono: (MM) at 3 V output	90 dB
(MC) at 3 V output	80 dB
Aux	98 dB
Input Terminals	
Phono: Input Impedance (MM)	47 k ohms
Input Capacitance	100 pF
Input Sensitivity (MM)	1.8 mV
Aux: Input Impedance	30 k ohms
Input Sensitivity	180 mV
Phono Equivalent Input Noise (MM)(IHF-A)	0.24 µV
Phono Dynamic Range (Ratio of input overload to equivalent input noise)	120 dB
Channel Balance (0 to -40 dB/40 Hz~16 kHz)	
Phono	1.0 dB
Aux	1.0 dB
Interchannel Crosstalk	
Phono 1 kHz	51 dB
Aux 1 kHz	56 dB
Tape 1 kHz	48 dB
Intersource Crosstalk (Worst Point)	
1 kHz	53 dB
Output Voltage, 1 kHz	
Tape Out (Input: Phono 7.75 mV)	775 mV
Pre Out (Input: Aux 180 mV)	1500 mV
Output Impedance, 1 kHz	
Tape Out	330 ohms
Pre Out	220 ohms

GENERAL

Power Requirements	220 V AC; 50 Hz
	(N version is featuring an external voltage selector for use on 110/120/240 V. Other versions can be converted by a qualified technician to operate on 110/120/240 V.)
Power Consumption at Rated Output, Both Channels Operating	11 W
Semiconductor Complement	
Transistors	37
Diodes	33
Field Effect Transistors	3
Dimensions	
Panel Width	16-3/8" (416 mm)
Panel Height	5-3/4" (146 mm)
Depth	9-3/4" (247 mm)
Weight	
Unit alone	14.5 lbs (6.6 kg)
Packed for shipment	17.6 lbs (8.0 kg)



marantz

MARANTZ CO., INC. · P. O. BOX 577 · CHATSWORTH, CALIFORNIA · 91311



A WHOLLY-OWNED SUBSIDIARY OF SUPERSCOPE INC., CHATSWORTH, CALIFORNIA · 91311