

Service Manual

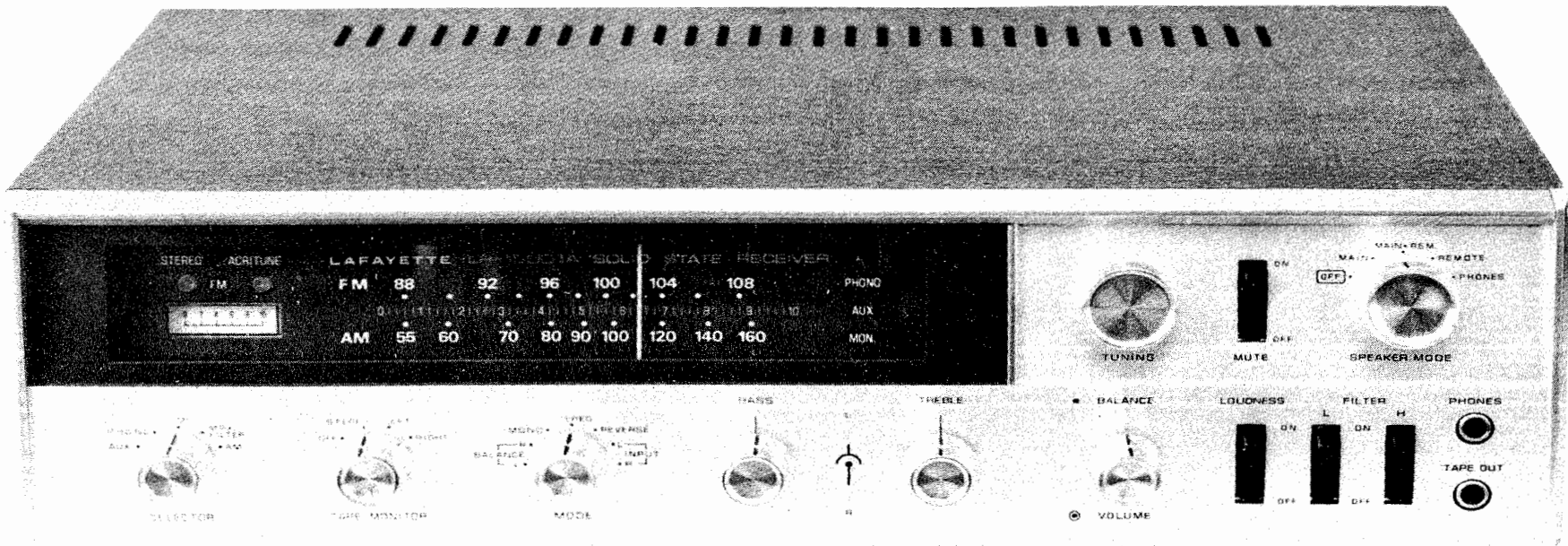

LAFAYETTE

Model LR-1500TA



Stock No. 99-01950WX

240-Watt Solid State AM/FM Stereo Receiver

This service manual has been carefully prepared to aid you in servicing the LAFAYETTE high fidelity receiver LR-1500TA.

Please follow the procedures outlined -- do not attempt short-cuts.

- * Always remove the AC power cord plug from the outlet when soldering or making repairs to the unit.
Wait until the power supply filters have dissipated their charge.
- * Do not use an ohmmeter to test transistors. In some instances the voltage across the test probes of an ohmmeter may exceed the base to emitter break-down voltage. Therefore, do not use an ohmmeter for testing transistors unless you are certain of the transistor's capability.
- * Do not replace a defective output transistor, until you have determined the cause of its failure. To assume it was a defective transistor only may result in further damage not only to the replacement, but to other transistors in that channel.
- * When installing a power transistor, make sure that the bottom of its mounting flange, surface of the heat sink and the insulator between them are free of dust and dirt particles. Failure to observe this precaution will prevent proper heat transfer and may even puncture the insulator, causing a short circuit to ground. Also, for proper heat transfer, both side of the insulator should be coated with silicone grease.
- * To prevent damage to the printed circuit boards and components, use the correct soldering iron; small diameter tip for single connection, large areas and special de-soldering tip for multiple connection component removal.
- * The following test equipments are required;
 - * AM/FM Signal Generator
 - * MPX Generator (with built-in RF output or used in conjunction with FM Signal Generator)
 - * DC V.T.V.M.

- * AC V.T.V.M.
- * Oscilloscope flat to 100 KHz
- * Audio Sine Wave Generator
- * I.M. Distortion Analyzer
- * Harmonic Distortion Analyzer
- * 10.7 MHz Sweep Generator
- * 455 KHz Sweep Generator
- * 2 pcs of 50W 4 or 8 ohm resistors

All voltage measurements should be made with the AC line adjusted to 117V. VTVM DC measurements are made to ground, with no signal input unless specified otherwise. Measurements may vary plus or minus 20%.

The circuits in this receiver have been designed so that realignment is not necessary when transistors or other small components are replaced in the front end, IF amplifier and multiplex decoder. Realignment is recommended only when it is absolutely necessary as indicated by sub-normal operation of the receiver, definitely attributed to misalignment.

Alignment should not be attempted unless the test equipment previously listed is available and the alignment procedure is thoroughly understood.

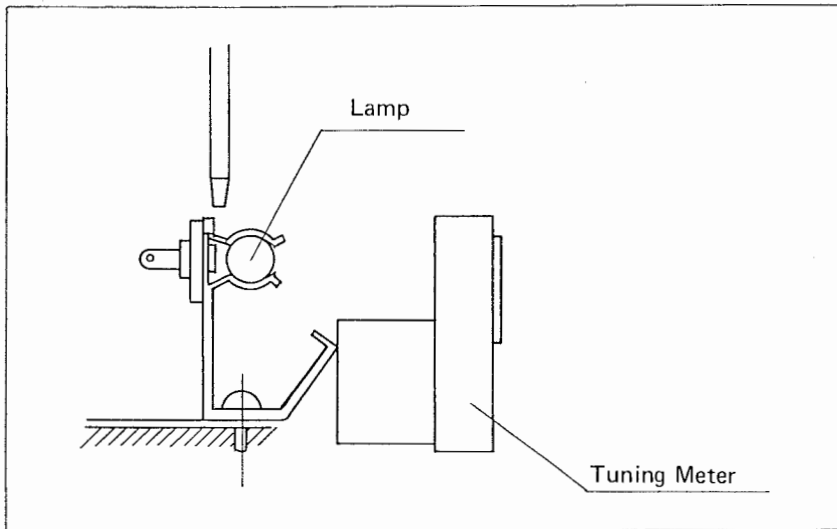

REPLACEMENT OF METER LAMP

Insert the blade of a screwdriver behind the lamp and lever the lamp out from its spring mounting. The blade should be inserted under the lamp at a point close to one of the retaining springs to avoid damage to the lamp. The replacement lamp is 8 volts, 0.25A (Green).

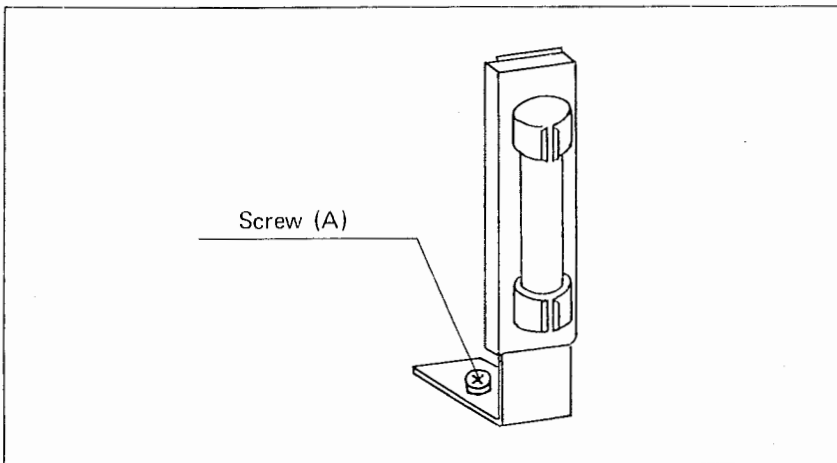

REPLACEMENT OF DIAL LAMPS

Remove Screw A to loosen bracket holding the lamp. Remove the lamp from the spring clips. Replacement lamp is 8 volts, 0.25A (Clear).

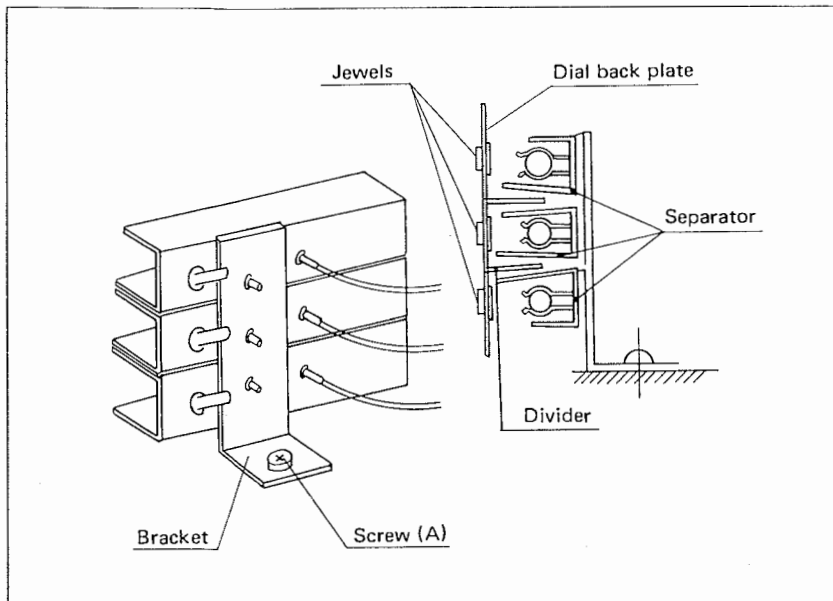

REPLACEMENT OF FUNCTION INDICATOR LAMPS

Remove Screw A and detach bracket holding indicator lamps. Be careful to insert separator correctly between divider as shown when re-mounting the bracket. Replacement lamp is 8 volts, 0.25A (Clear).

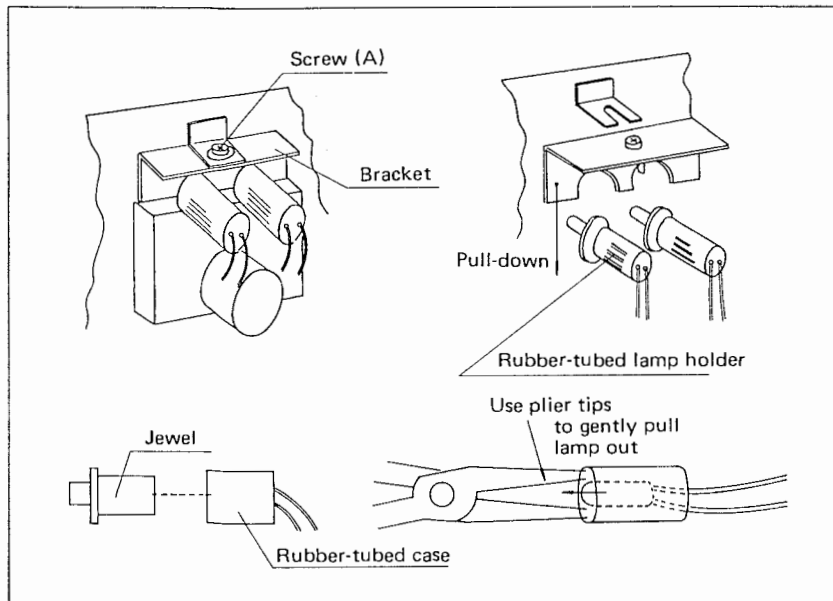

REPLACEMENT OF FM AND ACRITUNE LAMPS

Step 1: Remove Screw A and remove the bracket carefully. Use care when pulling the bracket back to avoid damaging the dial cord.

NOTE: On some units, Screw A and the bracket need not be removed because the bracket has been redesigned to permit sliding the holders out sideways.

Step 2: Remove the rubber-tubed lamp holder from bracket.

Step 3: The lamp is replaced as follows: Pull the plastic jewel out of the rubber-tubed case. Using small-nosed pliers, extract the lamp from within the tube as shown. Remove wires from old lamp, then solder wires to new lamp.

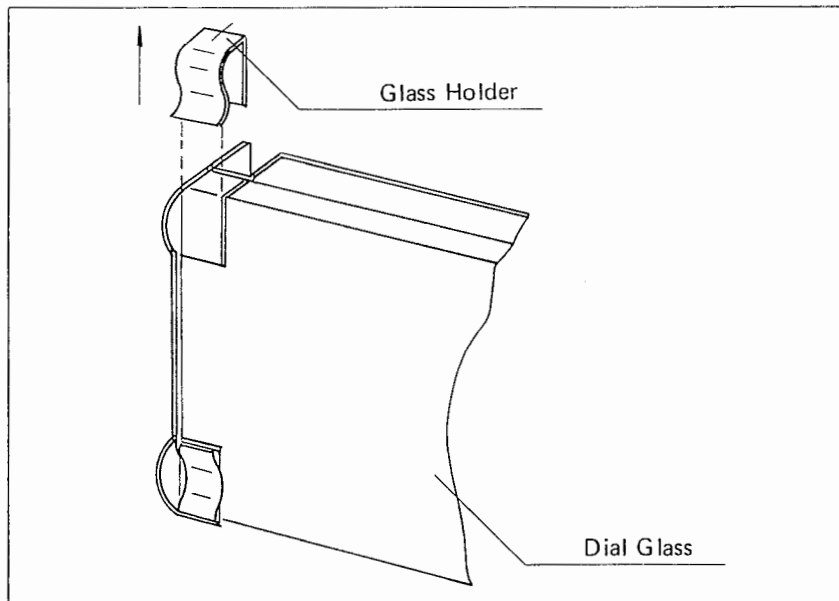

CLEANING THE DIAL GLASS

- * Remove front panel (see "Removing front panel").
- * Remove glass holder at both upper ends of dial glass by pulling them in an upward direction.
- * Pull dial glass in an upward direction to remove.
- * To clean the glass, use a soft, lint-free cloth.
- * Do not use a solvent for this purpose, and use a light rubbing motion to avoid erasure of the dial lettering.

DIAL CORD STRINGING

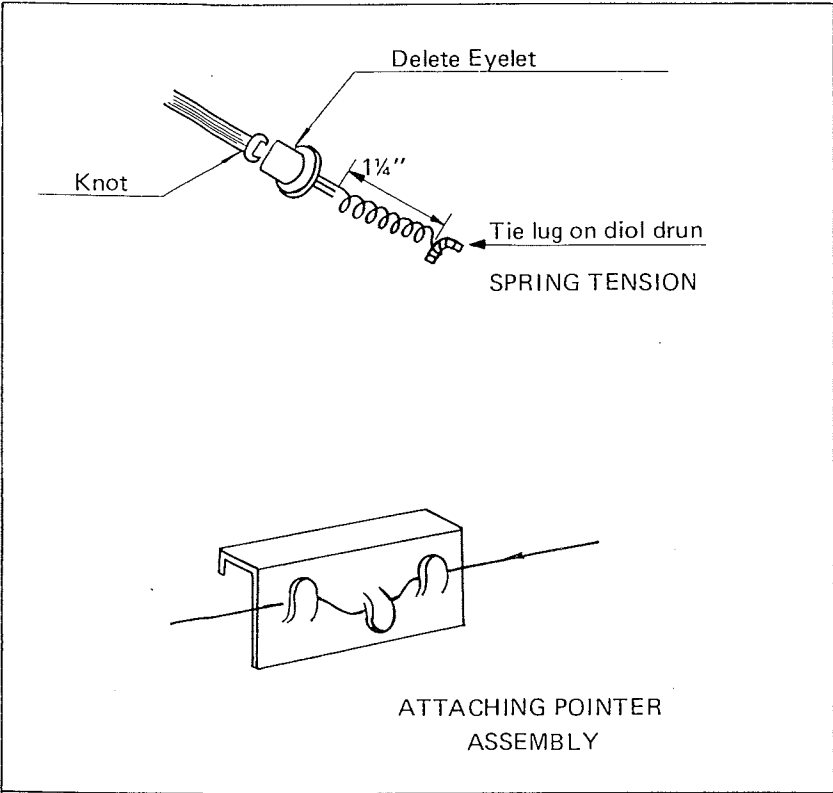
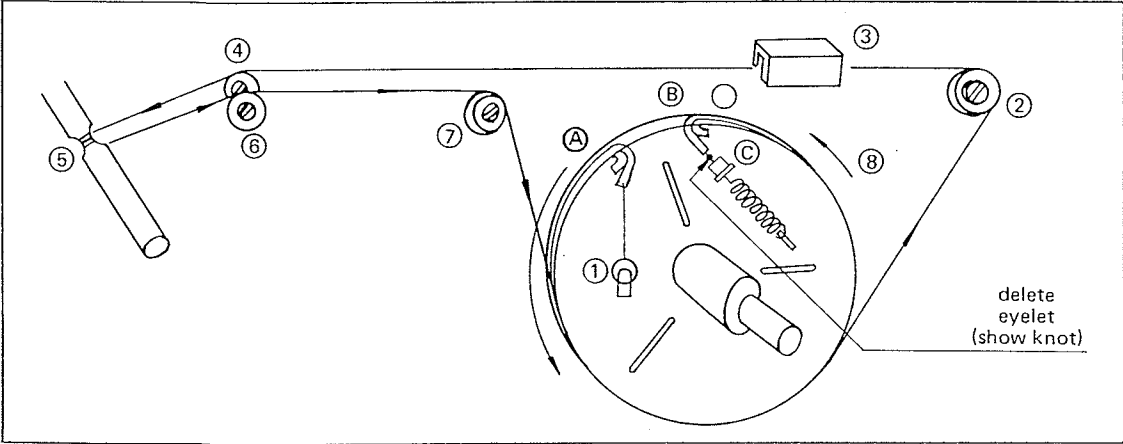

DIAL CORD STRINGING

- Step 1: Position dial drum as shown, and tie one end of a 4 ft length of dial string to Point 1.
- Step 2: Slip a length of soft plastic tubing (3/64" in diameter) over the string at Point A to prevent wearing of string, and then run in indicated direction around pulley at 2 and 4.
- Step 3: Make two full turns around tuning shaft (5) and run string in direction of 6, 7, and 8.
- Step 4: The same plastic tubing used at Point A should also be used at B.
- Step 5: Slip string through loop of spring at C and adjust tension of spring by pulling on string until the spring is expanded to a length of approximately 1 1/4". If tension is too weak, slipping will occur at tuning shaft. If tension is too strong, dial pointer will not run smoothly.
- Step 6: Fully mesh the tuning capacitor, then mount dial pointer assembly (3) as shown, with pointer set on "Zero" on logging scale. Attach securely to string by applying paint to the 3 tie lugs on the pointer assembly.

DISASSEMBLY OF THE UNIT

REMOVING CAGE

Remove 4 screws attaching cage on both sides of the unit.

REMOVING FRONT PANEL

Remove all control knobs (held by set-screws)
Remove 3 nuts attaching front panel to chassis.

REMOVING OF BOTTOM PLATE

Remove all screws attaching bottom plate to chassis.

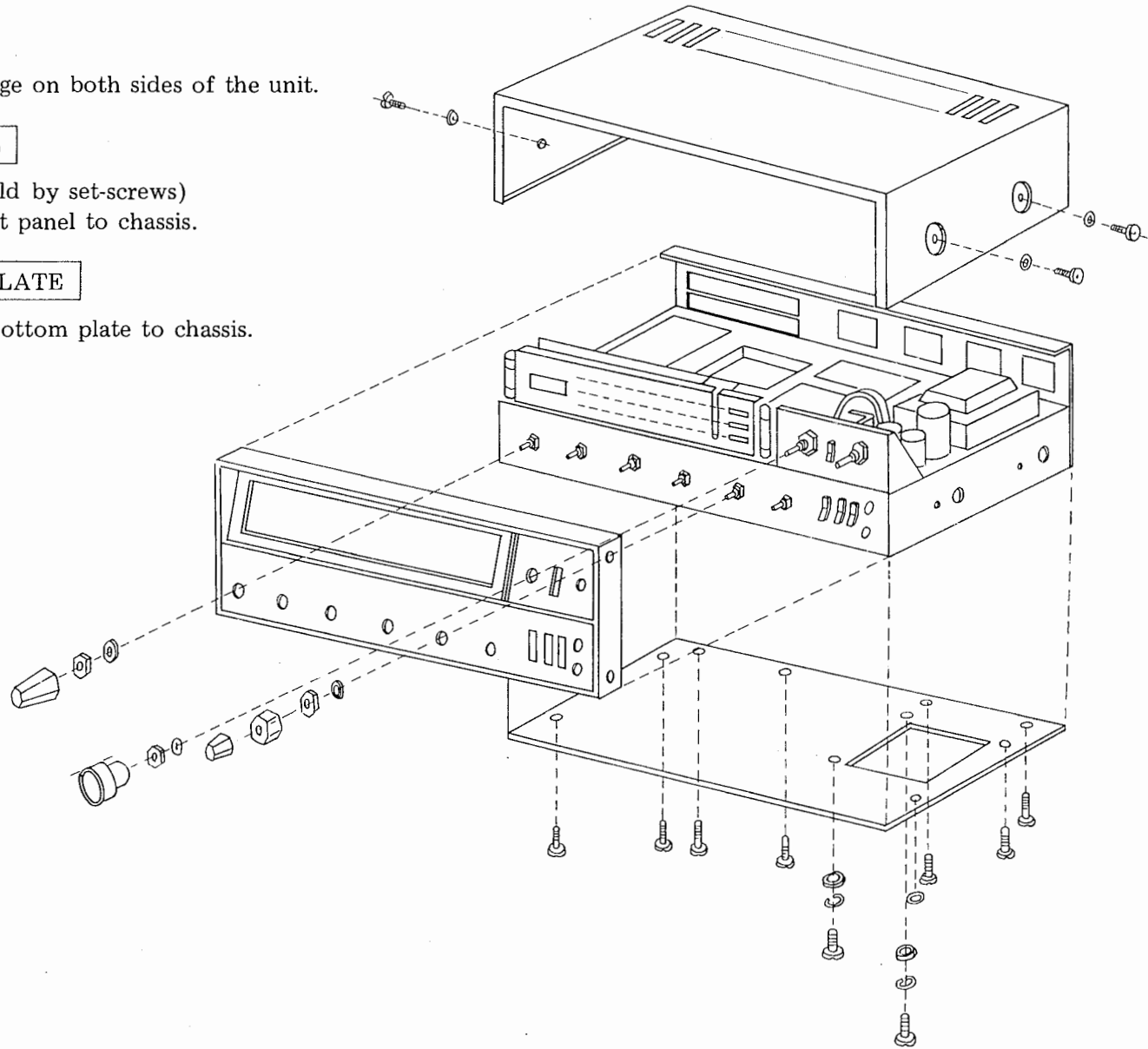

ADJUSTMENT PROCEDURE

MAIN AMP DC BIAS ADJUSTMENT (PC BOARD NUMBER : EPO-22)

INSTRUMENT : DC AMMETER and DC VOLTMETER

LEFT CHANNEL ADJUSTMENT

- 1 Set RV-402L to minimum position.
- 2 Remove any input signal and speaker load.
- 3 Connect DC VOLTMETER, high side to No-13L tie point, low side to chassis and read +34V on DC VOLTMETER by adjusting RV-401L.
- 4 Connect DC AMMETER high side to No-6L tie point, low side to Q-7 TRANSISTOR collector.
- 5 Adjust RV-402L for 30mA DC.

RIGHT CHANNEL ADJUSTMENT

* Repeat same above steps for right channel, but substitute the following:

- | | |
|-----------------------------------|--|
| Step 1: RV-402R | Step 4: Tie point No-6R, Q9 transistor |
| Step 3: Tie point No-13R, RV-401R | Step 5: RV-402R |

MAIN AMP BALANCE ADJUSTMENT (PC BOARD NUMBER : EPO-22)

INSTRUMENT : AC VTVM, AUDIO SIGNAL GENERATOR, and OSCILLOSCOPE

LEFT CHANNEL ADJUSTMENT

- 1 Set BALANCE CONTROL (left channel) to minimum, BASS and TREBLE CONTROLS to their center position.
- 2 Set MODE SWITCH to STEREO position, SPEAKER SWITCH to MAIN position and SELECTOR SWITCH to AUX position.
- 3 Connect 8-ohm (50W) resistor across L-MAIN SPEAKER TERMINALS.
- 4 In parallel with the load resistor, connect OSCILLOSCOPE and AC VTVM in parallel connection.
- 5 Connect AUDIO SIGNAL GENERATOR, set for 1KHz, to L-AUX INPUT. Output of AUDIO SIGNAL GENERATOR should be minimum.
- 6 Connect AC POWER CORD and switch power-on. Rotate VOLUME CONTROL (left channel) to its maximum clockwise position.
- 7 Increase AUDIO SIGNAL GENERATOR output until sine wave on SCOPE just starts to clip.

8 Adjust RV-401L for equal clipping on the positive and negative half cycles of the signal as shown below.

RIGHT CHANNEL ADJUSTMENT

* Repeat same above steps for right channel, but substitute the following:

Step 1: Right channel BALANCE CONTROL

Step 5: R-AUX INPUT

Step 3: R-MAIN SPEAKER TERMINALS

Step 6: Right channel VOLUME CONTROL

Step 8: Adjust RV-401R

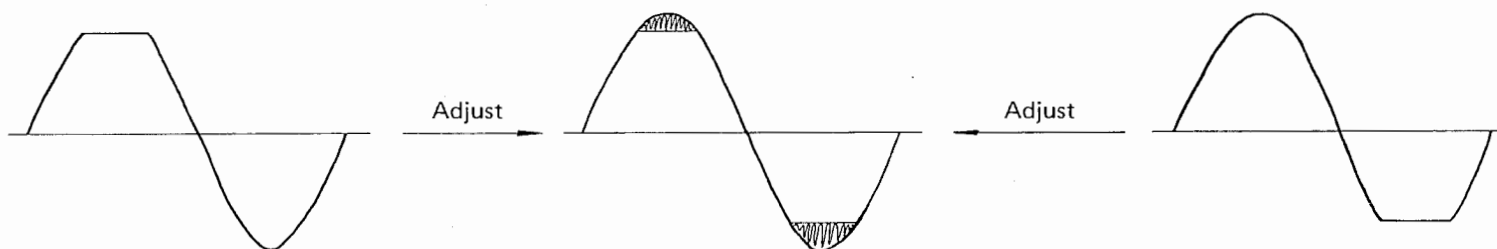

“COMPUTOR-MATIC” CIRCUIT ADJUSTMENT (PC BOARD NUMBER : EPO-22)

Before adjusting this CIRCUIT, BIAS and BALANCE ADJUSTMENT have to be completed.

INSTRUMENT : AC VTVM, AUDIO SIGNAL GENERATOR, OSCILLOSCOPE and DC VOLTMETER (1V Range)

LEFT CHANNEL ADJUSTMENT

- 1 Comment 4-ohm (50W) resistor across L-MAIN SPEAKER TERMINALS.
- 2 Connect DC VOLTMETER, high side to No-16L tie point, low side to No-13L tie point and adjust RV-403L until reading on VOLTMETER shows “zero” volts.
- 3 Connect AUDIO SIGNAL GENERATOR, set for 1KHz, using RCA PLUG, to L-AUX INPUT.
Output of AUDIO SIGNAL GENERATOR should be minimum.
- 4 In parallel with the load resistor, connect OSCILLOSCOPE and AC VTVM in parallel connection.
- 5 Rotate VOLUME CONTROL (left channel) to maximum position.
- 6 Increase output of AUDIO SIGNAL GENERATOR until sine wave on scope just starts to clip.
- 7 Connect OSCILLOSCOPE, high side to No-13L tie point, low side to No-17L tie point and adjust RV-404L.
Response curve should be as in figure below and the height of curve should be adjusted to minimum.

RIGHT CHANNEL ADJUSTMENT

* Repeat same above steps for right channel, but substitute the following:

Step 1: R-MAIN SPEAKER TERMINALS.

Step 5: Right-channel VOLUME CONTROL.

Step 2: Tie points No-16R, 13R, RV-403R.

Step 7: Tie points No-13R, 17R, RV-404R.

Step 3: R-AUX INPUT.

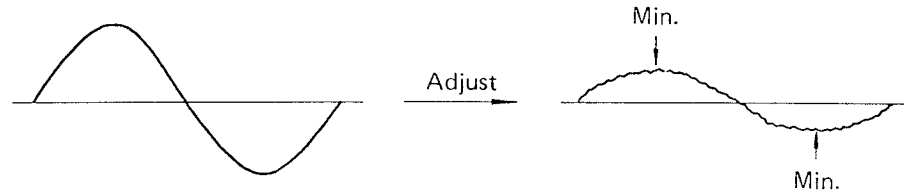

PRE-AMPLIFIER ADJUSTMENT (PC BOARD NUMBER : EPO-19)

INSTRUMENT : AUDIO SIGNAL GENERATOR, AC VTVM and OSCILLOSCOPE

LEFT CHANNEL ADJUSTMENT

- 1 Set VOLUME CONTROLS to minimum, SELECTOR SWITCH to AUX position.
- 2 Connect AUDIO SIGNAL GENERATOR, set for 1KHz, to AUX INPUTS (L & R) using RCA PLUGS.
- 3 Connect AC VTVM and OSCILLOSCOPE to L-TAPE REC. OUTPUT in parallel connection.
- 4 Increase AUDIO SIGNAL GENERATOR output until sine wave on SCOPE just start to clip.
- 5 Adjust RV-203 on the left channel for equal clipping on the positive and negative half cycles of the signal as shown in figure below.

RIGHT CHANNEL ADJUSTMENT

* Repeat same above steps for right channel by adjusting RV-204 with AC VTVM and OSCILLOSCOPE connected to R-TAPE REC. OUTPUT.

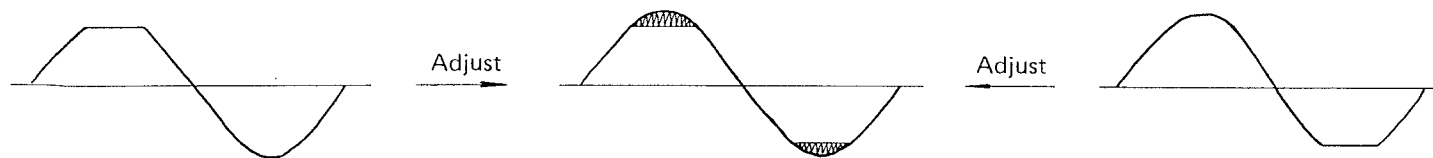

ALIGNMENT PROCEDURE

Please read the following notes carefully before attempting any alignments or adjustments.

1 Generator signal

Always work with the minimum generator signal sufficient to produce a satisfactory output indication.

2 Dial Pointer

Check dial pointer for alignment at left-hand start mark. (Logging scale " zero")

3 FM, AM and MPX FILTER alignment

Set VOLUME/BALANCE CONTROL to minimum position.

FM SECTION ALIGNMENT (PC BOARD NUMBER : EPO-18)

INSTRUMENT : FM SIGNAL GENERATOR, AC VTVM, OSCILLOSCOPE and FM IF SWEEP GENERATOR

Step	Dummy Antenna	Coupling of FM Signal Generator	Frequency of FM Signal Generator or FM IF Sweep Generator	Selector Switch Position	Tuning Dial Pointer Setting	Connection of FM IF Sweep Generator (Output)	Connection of VTVM and Oscilloscope (Input)	Test Equipment Set-up	Adjustment	Reading on VTVM and Scope
1			10.7 MHz on FM IF Sweep Generator	FM	No-Signal Position	High side to Q-103 GATE, low side to chassis.	High side to No-5 tie point, low side to chassis.	Fig - A	T-105 and T-106 top and bottom cores	Max. reading on VTVM and the best response curve as shown in Fig - C
2			Same as above	AUX	Same as above	High side to No-5 tie point, low side to chassis.	High side to No-11 tie point, low side to chassis.	Fig - A	T-107 and T-108 top and bottom cores	Same as above
3			Same as above	AUX	Same as above	High side to No-11 tie point, low side to chassis.	High side to No-14 tie point, low side to chassis.	Fig - B	T-109 top and bottom cores	Max. reading and response curve as shown in Fig - D
4	300Ω Dummy Antenna	To EXT. ANT TERMINALS of receiver through Dummy Antenna	90 MHz 400 Hz Mod. 75 KHz FM Dev. on FM SIGNAL GENERATOR	FM	90 MHz		To TAPE REC OUTPUT (L or R)	Fig - H	T-101 to T-104	Max. reading and response curve as Fig - E
5	300Ω Dummy Antenna	Same as above	106 MHz 400 Hz Mod. 75 KHz FM Dev. on FM SIGNAL GENERATOR	FM	106 MHz		Same as above	Same as above	CT-101 to CT-104	Same as above and response curve as Fig - E
6	Repeat same steps 4 and 5 until no further improvements are produced									

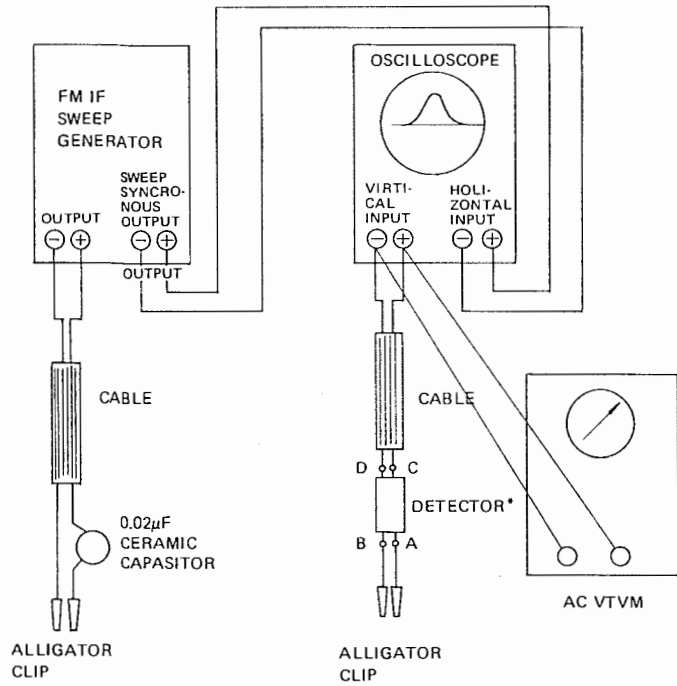

FIGURE - A

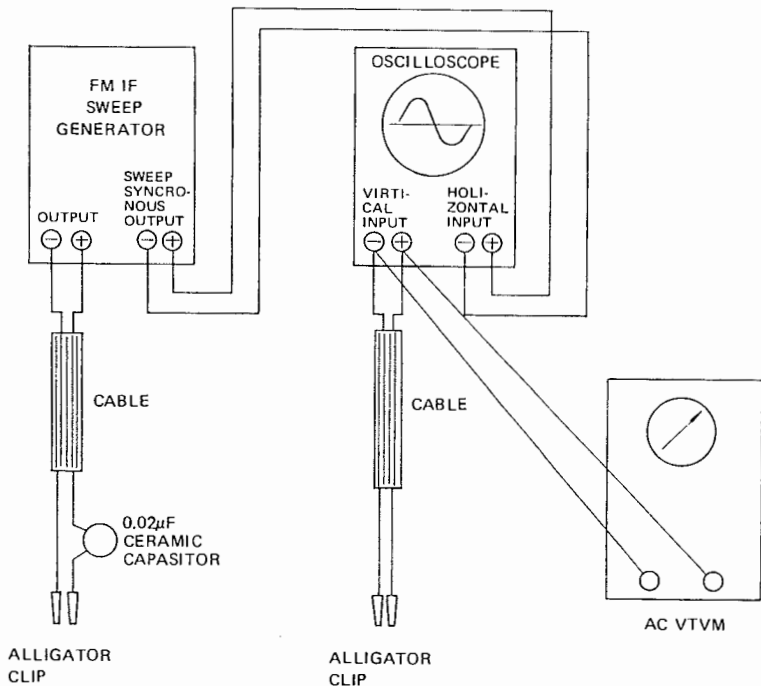
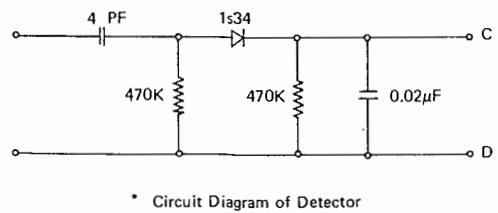

FIGURE - B



* Circuit Diagram of Detector

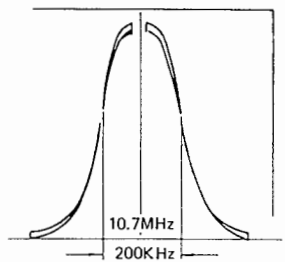

FIGURE - C

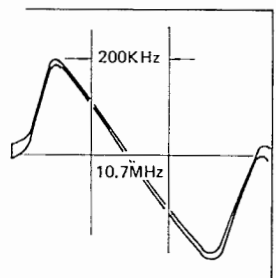

FIGURE - D

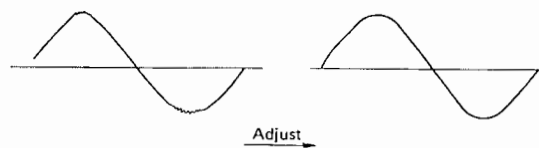
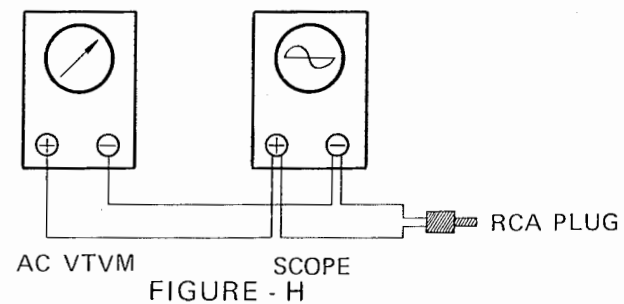
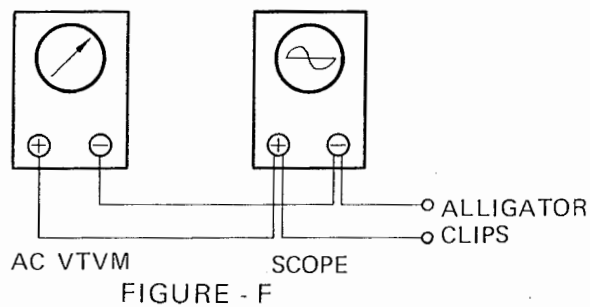

FIGURE - E

MPX SECTION ALIGNMENT (PC BOARD NUMBER : EPO-19)

INSTRUMENT : AUDIO SIGNAL GENERATOR, MPX SIGNAL GENERATOR, AC VTVM and OSCILLOSCOPE

Step	Dummy Antenna	Coupling of MPX Signal Generator or Audio Signal Generator	MPX Signal Generator Frequency	Selector Switch Position	Tuning Dial Setting	Connection of VTVM and Oscilloscope	Test Equipment Set-up	Adjust	Reading on VTVM and Scope
1		Audio Signal Generator high side to EPO-19 No-22 tie point, low side to chassis	Adjust Frequency of Audio Signal Generator 66KHz (0.5V) and 68KHz (0.5V)	AUX	No-Signal Position	High side to EPO-19, Q-201 base. low side to chassis	Fig-F	T-201 (68KHz) and T-202 (66KHz)	Minimum reading on VTVM.
2	300Ω Dummy Antenna	MPX Signal Generator To External Antenna terminal through 300Ω Dummy Antenna	100 MHz 19 KHz Pilot only. 7.5 KHz Dev.	FM (Mode Switch Stereo)	100 MHz	High side to EPO-19, D-205 anode, and low side to chassis	Fig-F	T-205, 206 and 207	Maximum reading on VTVM.
3	300Ω Dummy Antenna	Same as above	Same as above	FM (Mode Switch Mono)	100 MHz	Tape Rec. Terminal. (L or R)	Fig-H	T-203	Minimum reading on VTVM
4	300Ω Dummy Antenna	Same as above	Composite MPX signal 400 Hz on LEFT CHANNEL only. 75 KHz Dev.	FM (Mode Switch Stereo)	100 MHz	Right Channel Tape Rec. Output	Same as above Fig-H	RV-202 and T-205	Same as above
5	300Ω Dummy Antenna	Same as above	Composite MPX Signal 400 Hz on RIGHT CHANNEL only.	Same as above	100 MHz	Left Channel Tape Rec. Output	Fig-H	RV-201 and T-205	Same as above
6	Repeat steps 4 and 5 until no further improvements are produced								



TUNING METER ALIGNMENT (EPO-18)

INSTRUMENT : FM SIGNAL GENERATOR

Step	Dummy Antenna	Coupling of Signal Generator	Signal Generator Frequency and Output Level	Selector Switch Position	Tuning Dial Setting	Indicator	Adjustment	Reading on Indicator
1	300 Ω Dummy Antenna	To external Antenna terminals through 300 Ω Dummy Antenna	98 MHz 400 Hz Mod. 75 KHz Dev. Level : 10 mV Output	FM	98 MHz	Tuning Indicator	RV-101	"9" on scale

MUTING ADJUSTMENT (PC BOARD NUMBER : EPO-18)

INSTRUMENT : FM SIGNAL GENERATOR and STEREO HEAD PHONES

- 1 Connect FM SIGNAL GENERATOR to EXT. ANT TERMINALS through 300 Ω DUMMY ANTENNA.
- 2 Set SELECTOR SWITCH to FM position, TUNING DIAL POINTER on 98 MHz.
- 3 Insert STEREO HEAD PHONES into PHONES JACK in front panel of receiver.
- 4 Set VOLUME CONTROL 9 to 12 o'clock position.
- 5 Increase input voltage of SIGNAL GENERATOR generally from zero until TUNING INDICATOR indicates 3.5 on its scale.
- 6 Switch-on MUTE SWITCH and rotate RV-102 until output of STEREO HEAD PHONES for the thresh-hold condition.

ACRITUNE INDICATOR ALIGNMENT (PC BOARD NUMBER : EPO-19)

- 1 Set SELECTOR SWITCH on FM position and disconnect FM EXT. ANTENNA.
- 2 Adjust R-210 POTENTIOMETER so that ACRITUNE LAMP is not lit by irregular signal level (Noise Level) while tuning over the entire 88 to 108 MHz band.

AM SECTION ALIGNMENT (PC BOARD NUMBER : EPO-18)

INSTRUMENT : AM SIGNAL GENERATOR and LOOP ANTENNA

Step	Dummy Antenna	Coupling of Signal Generator	Signal Generator Frequency	Selector Switch Position	Tuning Dial Setting	Indicator	Adjustment	Reading on Tuning Meter	Remarks
1		High side to Q-106 base through 0.02 μ F ceramic capacitor, low side to chassis	455 KHz 400 Hz, 30% AM Mod.	AM	No-Signal Position	Tuning Meter	EPO-18 T-112 to T-114 top and bottom cores	Maximum Deflection	Output of SIGNAL GENERATOR must be kept low so that the reading of TUNING METER does not exceed "6" on its scale
2	Loop Antenna	To loop Antenna and make distance of about 2 Feet between loop antenna and receiver	600 KHz 400 Hz, 30% AM Mod.	AM	600 KHz	Tuning Meter	EPO-18 T-110 and T-111	Maximum Deflection	
3	Loop Antenna	Same as above	1400 KHz 400 Hz, 30% AM Mod.	AM	1400 KHz	Tuning Meter	EPO-18 CT-105 to CT-107	Maximum Deflection	
4	Repeat steps 2 and 3 until no further improvements are produced								

AM/FM, TUNER, IF SECTION PC BOARD ASSEMBLY (EPO-18)

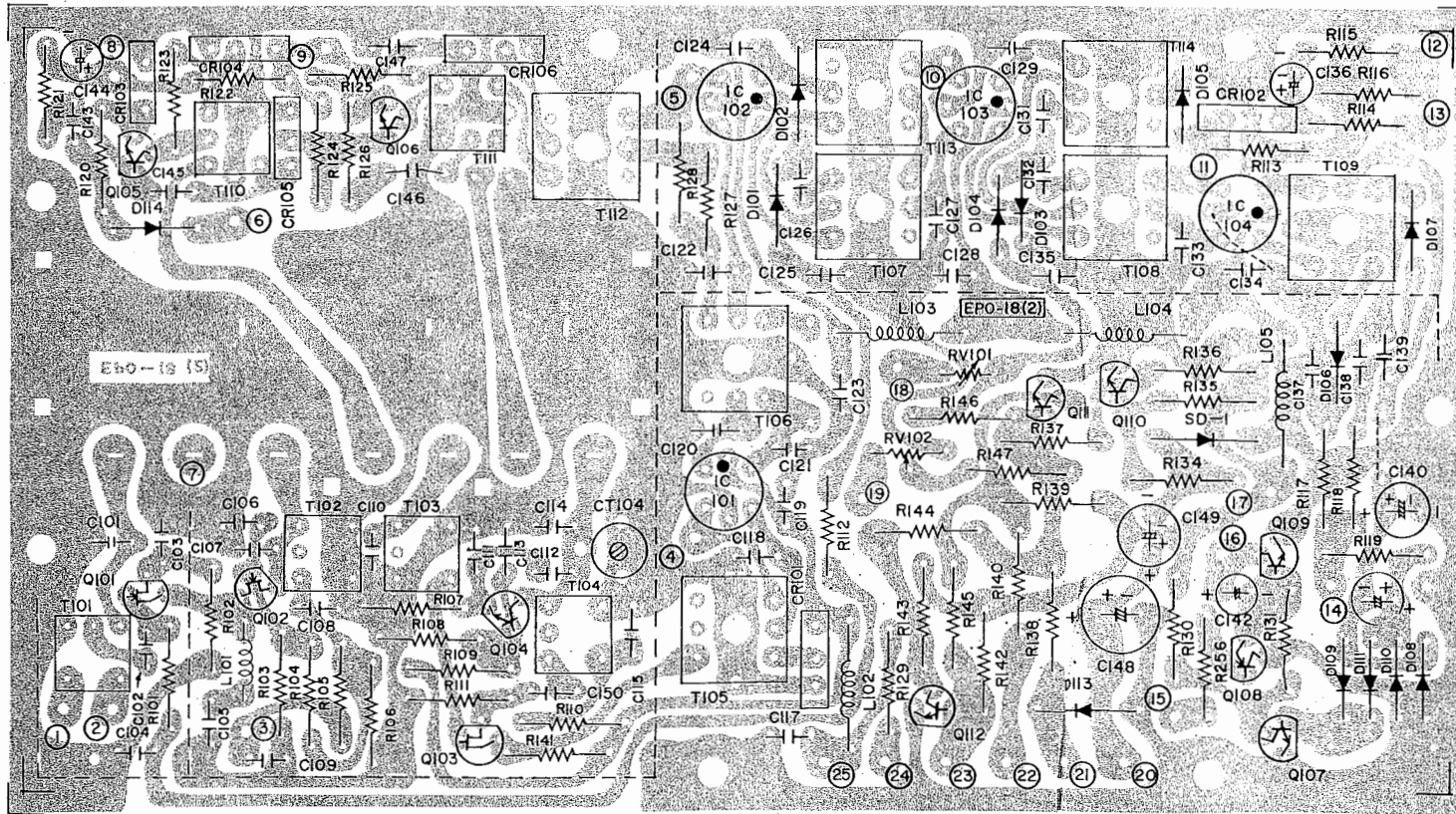

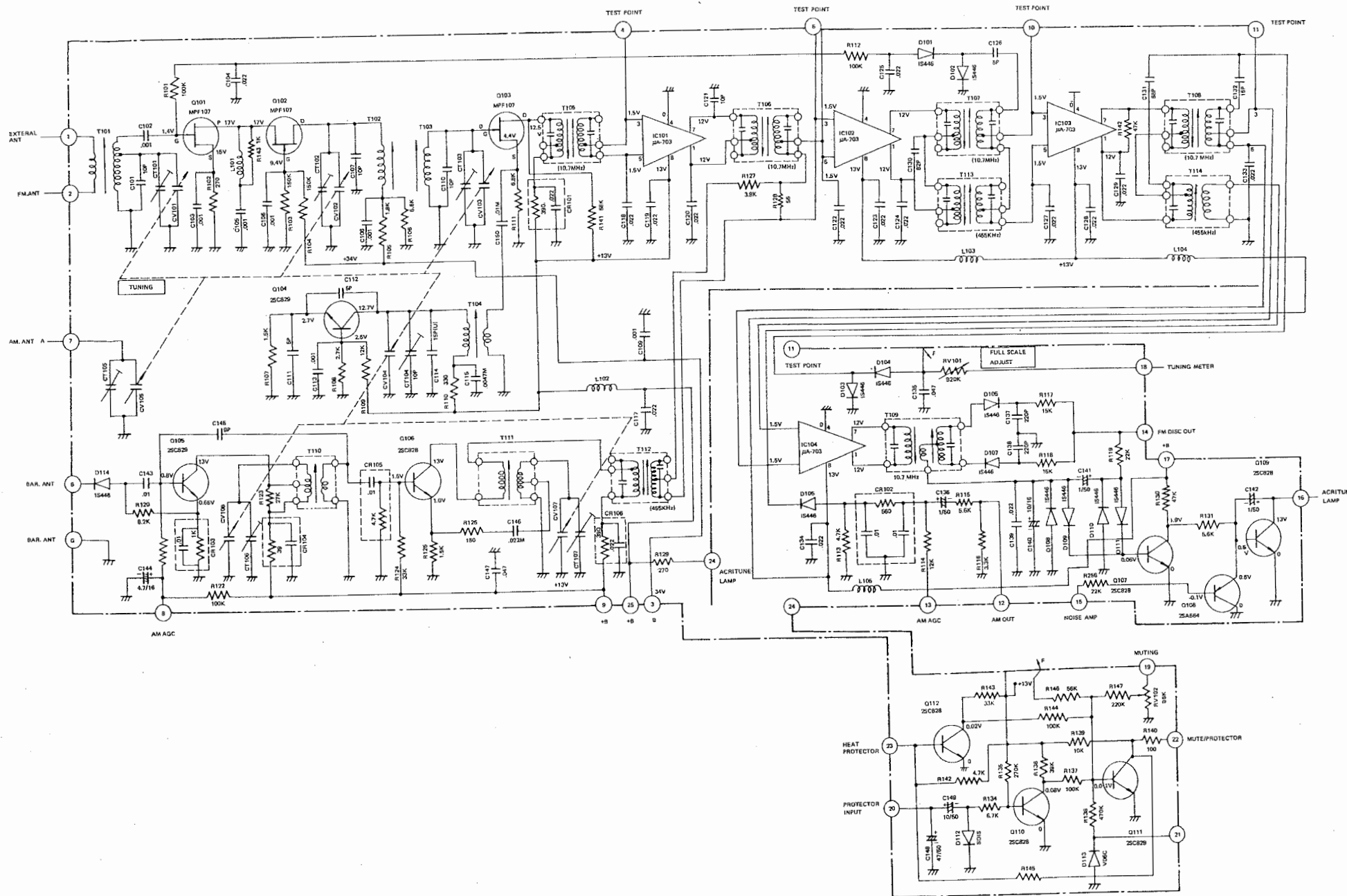

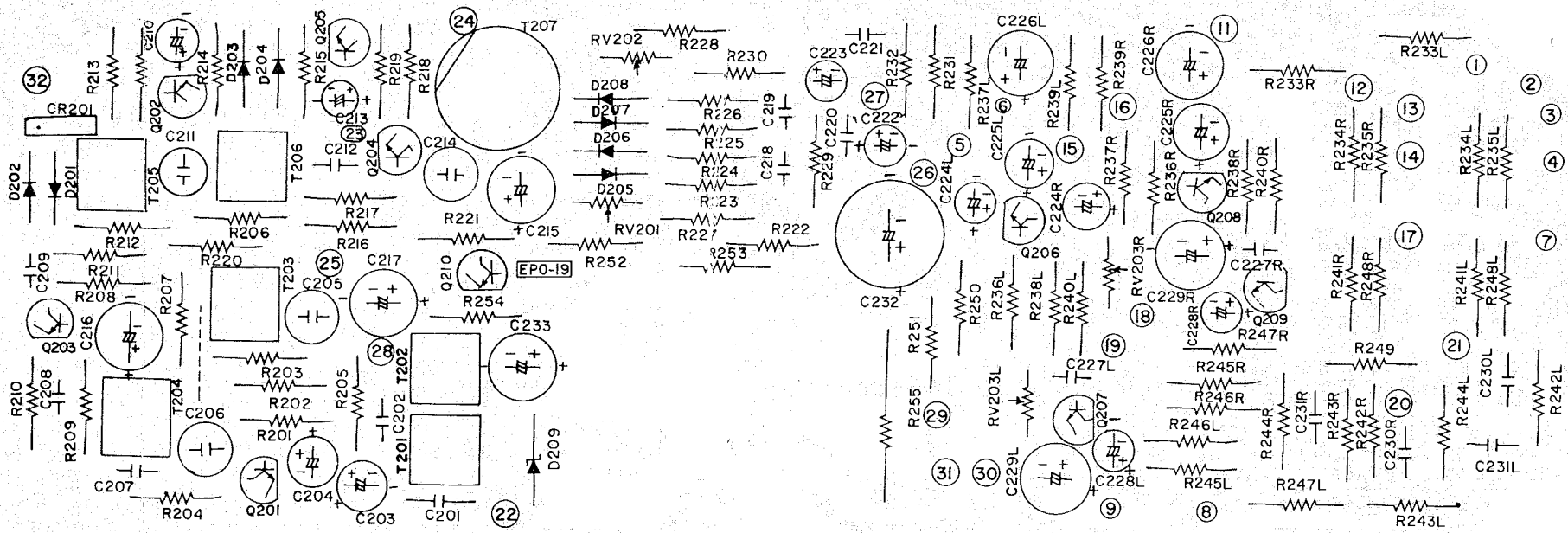

MAIN AMPLIFIER PC BOARD ASSEMBLY (EPO-22)

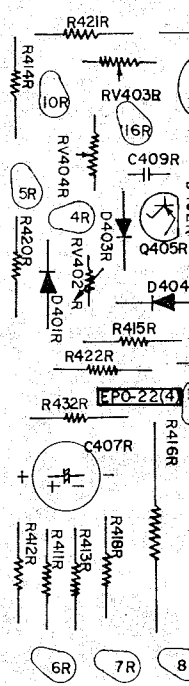
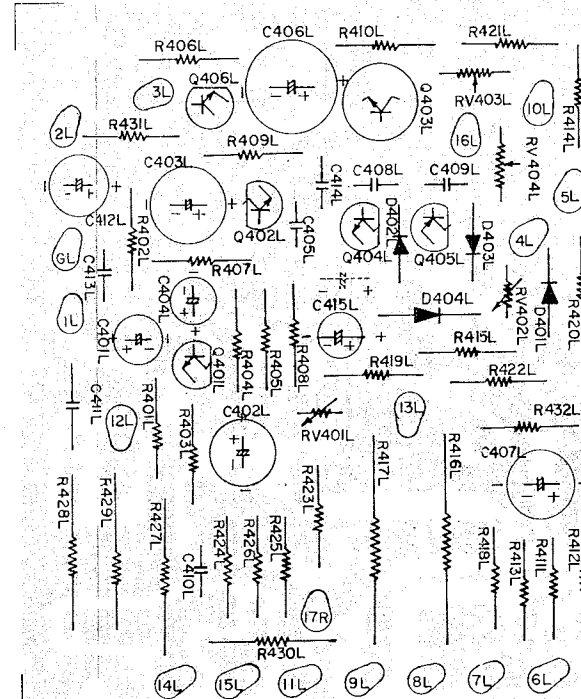
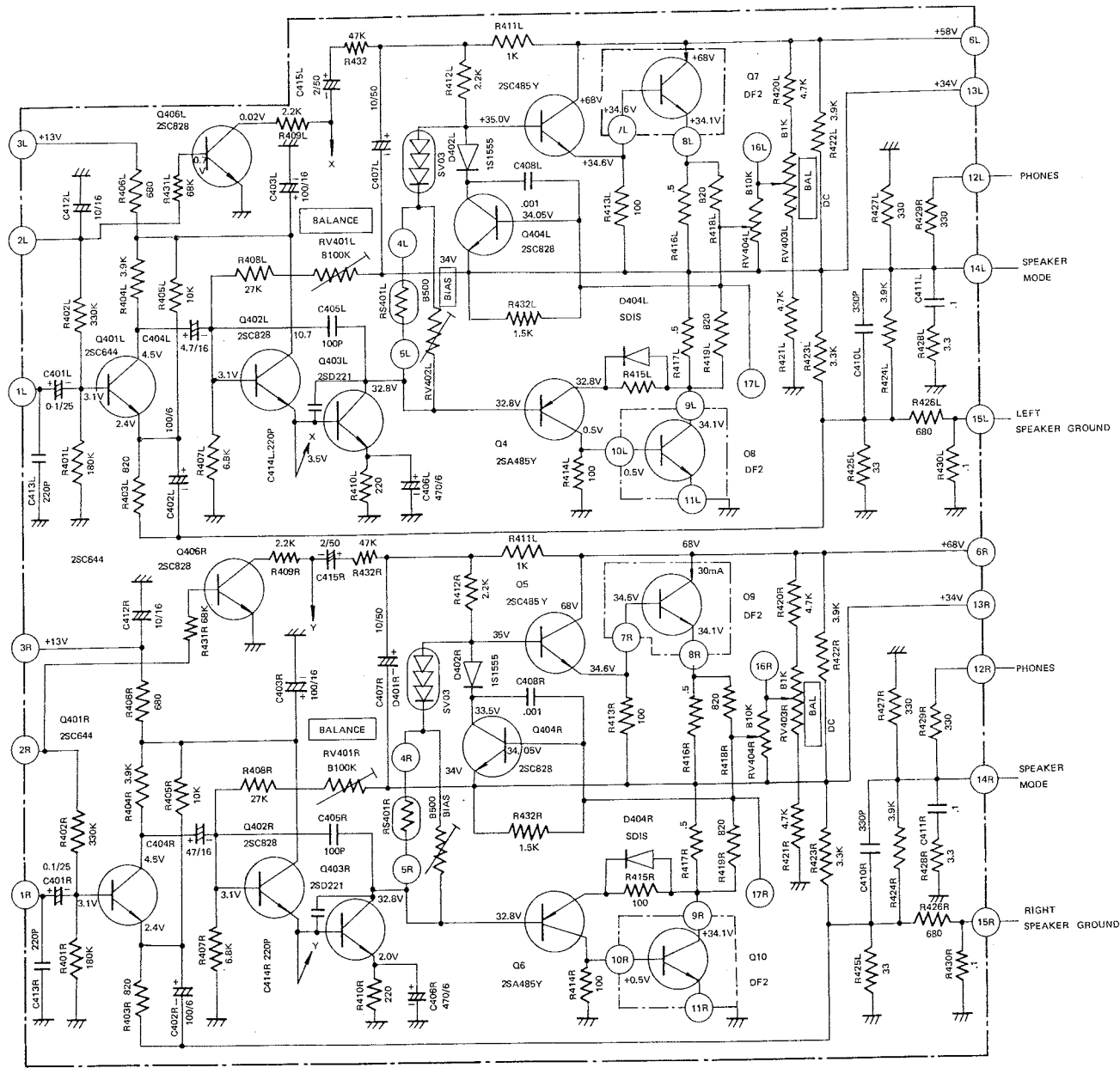

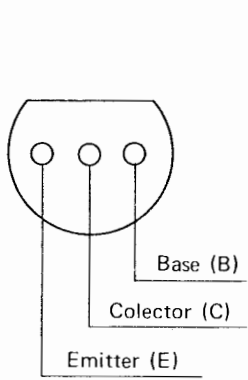

2SC828,	2SC644
2SC829,	2SA564
2SA564A	

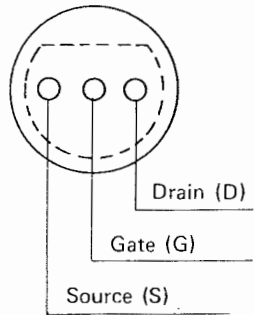

2SK30
2SK17

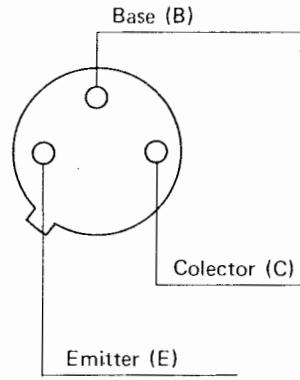

2SD221,	2SD224
2SC538,	2SA550
2SC627	

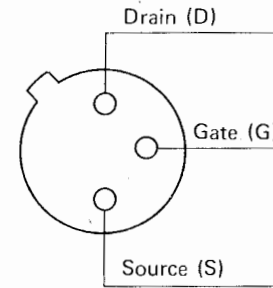

1T-107

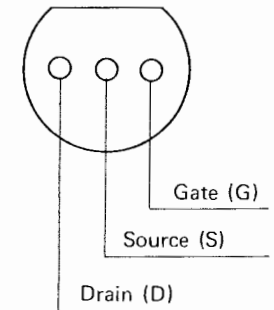

2N5486 (MPF-107)

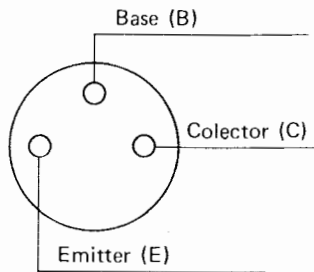

2N4356,	CS-1504
CS-1502A	
CS-1502B	
CS-1503	

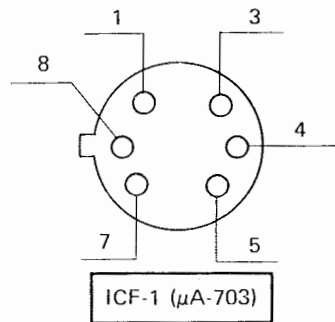

ICF-1 (μ A-703)

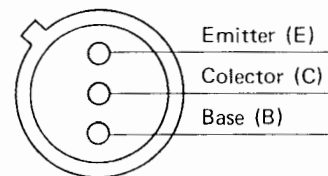

2SC645

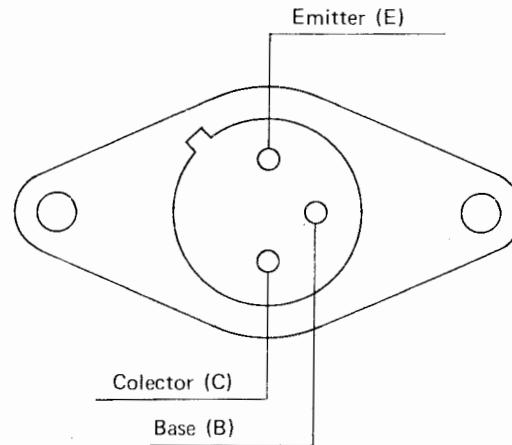

2SC485,
2SA485,
2SA546

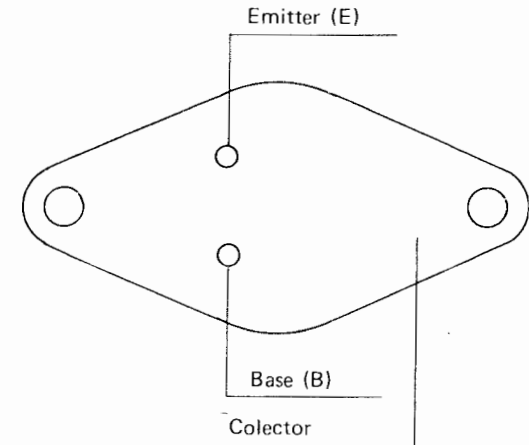

2SD142,	2SB481,	2SD236
2SDF2,	2SDF45	2SD238
2SD91,	2SD90	

TONE CONTROL PC BOARD ASSEMBLY (EPO-20)

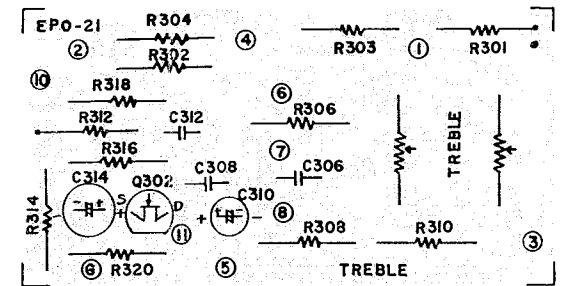
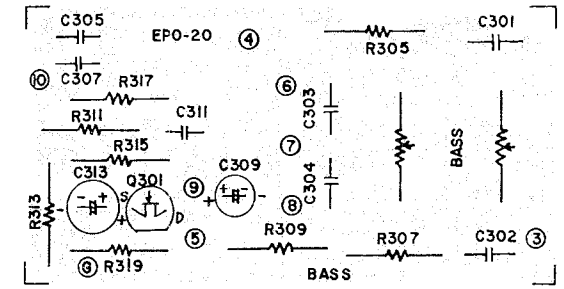
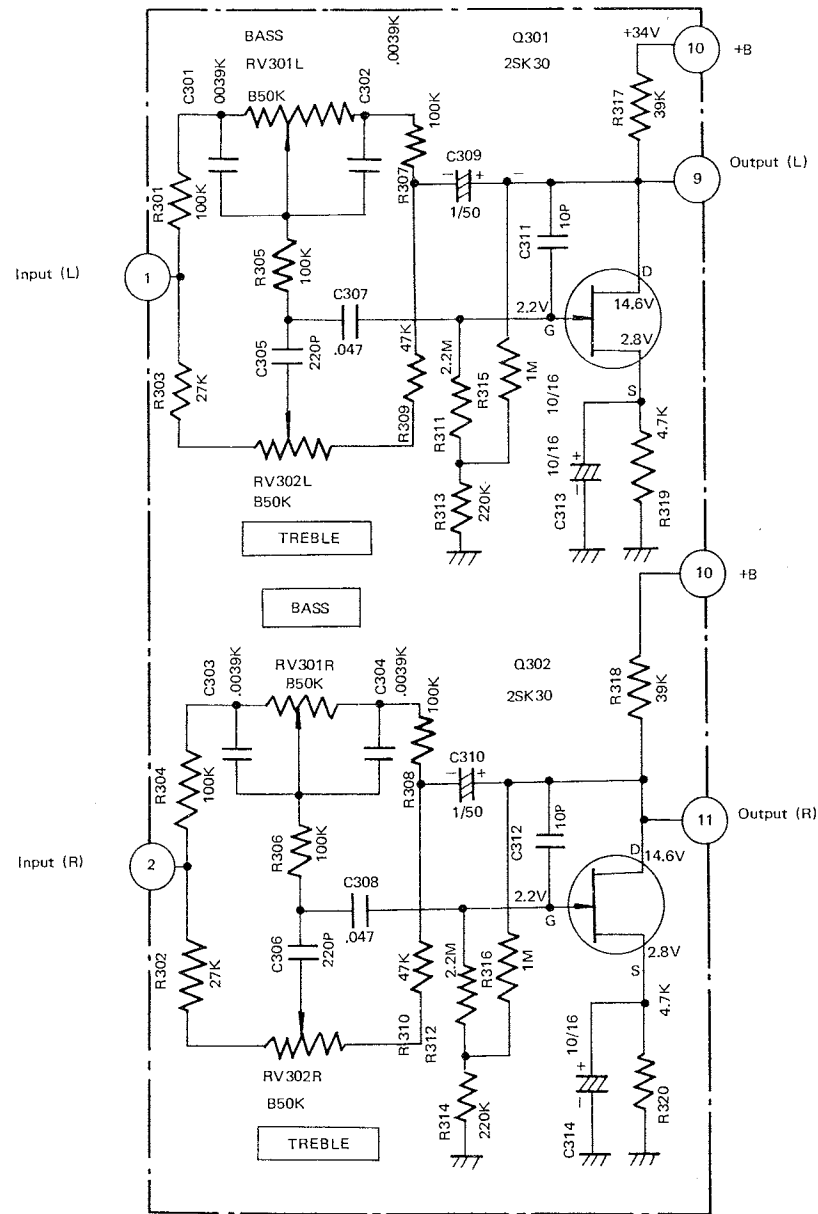

PARTS LOCATION LR-1500TA

