

**KT-250A**

a s s e m b l y

m a n u a l

**LAFAYETTE**

**50 WATT INTEGRATED  
STEREO AMPLIFIER**

Price 50c

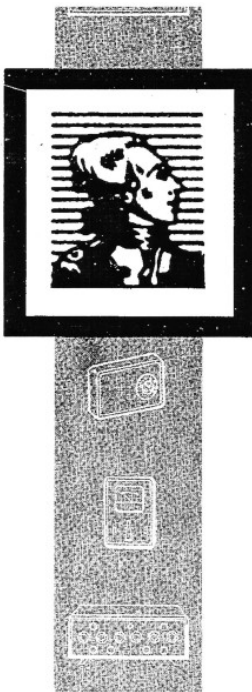

## STANDARD COLOR CODE

RESISTORS AND CAPACITORS				
INSULATED UNINSULATED	FIRST RING BODY COLOR	SECOND RING END COLOR	THIRD RING DOT COLOR	FOURTH RING END COLOR
Color	First Figure	Second Figure	Multiplier	Tolerance
BLACK	0	0	1	
BROWN	1	1	10	
RED	2	2	100	
ORANGE	3	3	1,000	
YELLOW	4	4	10,000	
GREEN	5	5	100,000	
BLUE	6	6	1,000,000	
VIOLET	7	7	10,000,000	
GRAY	8	8	100,000,000	
WHITE	9	9	1,000,000,000	
GOLD				5%
SILVER				10%
NO COLOR				20%

**AXIAL LEAD RESISTOR**

**MOLDED MICA TYPE CAPACITORS**

CURRENT STANDARD CODE

**5-DOT RADIAL LEAD CERAMIC CAPACITOR**

**MOLDED PAPER TYPE CAPACITORS**

TUBULAR CAPACITOR

**EXTENDED RANGE TC CERAMIC HICAP**

**BY-PASS COUPLING CERAMIC CAPACITOR**

## SPECIFICATIONS

The KT-250-A you have purchased is an improved version of the original KT-250. Modifications include changes to front panel styling and also to the circuitry, resulting in a unit that is greatly enhanced both in appearance and performance. For convenience, the suffix letter A has not been added to the Kit number in the text of the construction manual and on the Pictorial Inserts.

### POWER OUTPUT

AND DISTORTION .... 25 watts  $\pm 1$  db at less than 1% total harmonic distortion at 1 KC.

Less than 0.25% total harmonic distortion at 1 KC at normal listening level (1 watt); less than 0.5% IM (60 cps and 7 KC, 4:1) at normal listening level.

FREQUENCY RESPONSE .. 15-40,000 cps  $\pm 0.5$  db (at normal listening level)  
20-50,000 cps  $\pm 1$  db at rated output.

SENSITIVITY ..... For full output: High level inputs 0.5 V; Mag. Phono inputs 3.5 MV at 1 KC.

CHANNEL SEPARATION.. Greater than 55 db at 1 KC; greater than 45 db from 20-20,000 cps.

TONE CONTROL RANGE.. Treble control: 12.5 db boost or cut at 10 KC.  
Bass control: 15.5 db boost or cut at 50 cps.

HUM AND NOISE ..... Zero volume hum: 77 db below rated output.  
Maximum volume hum: High level inputs, 70 db below rated output;  
Mag. Phono inputs, 50 db below rated output.

INPUTS ..... (5 pairs) - Mag. Phono, Ceramic/Crystal, Tuner, Aux, Tape Head.

OUTPUTS ..... (5) - Dual 4, 8 and 16 ohms, Dual Tape out, Bridged Out.

TUBE COMPLEMENT ... 4-6CW5/EL86, 2-7199, 3-12AX7, 3-Silicon diodes.

POWER CONSUMPTION.. 200 watts.

DIMENSIONS ..... Overall, 14-1/2" W x 12-3/4" D x 5-1/2" H.

SHIPPING WEIGHT ..... 28 lbs.

## UNPACKING INSTRUCTIONS

Unpack the kit carefully, and check each part against the parts list before starting construction. A color code chart on the inside front cover of the assembly manual, and a parts identification chart are provided to help you identify parts and determine component values. Some components may differ slightly from the specified values given in the parts list. Such minor differences (where the supplied value falls within the listed tolerance for the component, such as a 510K resistor for a 470K 10% resistor) do not indicate an error. These substitutions are checked carefully before being made, and are only made in circuits allowing such substitutions.

As you unpack the kit and check the various components against the parts list, you may find it to your advantage to group certain parts and place them in suitable containers. In any event, the parts should be placed where they are readily available and will not become lost or damaged.

Any large variation from the specified value or shortage of parts should be reported to us immediately. Include with your letter the inspection slip from the package.

### DAMAGE IN SHIPMENT

If your kit was damaged in shipment, obtain a report from your express agent or trucker and mail it to: Kit Adjustment Division, Lafayette Radio, 111 Jericho Turnpike, Syosset, Long Island, N. Y. Do not return any parts until you receive instructions from us.

### REPLACEMENT WARRANTY

Lafayette Radio will replace, free of charge, any parts which become defective within 1 year from date of purchase of this kit by the original purchaser. Such replacement will be made only in cases where parts were defective at the time of sale or became defective in normal operation during the 1 year warranty period. Parts damaged during kit construction or through customer's wiring error are not subject to replacement.

## PARTS LIST

<u>PART NO.</u>	<u>DESIGNATION</u>	<u>DESCRIPTION</u>	<u>QUANTITY</u>
<b>CAPACITORS</b>			
12-1	C1, C18	120 $\mu\text{f}$ 10% ceramic disc	2
12-12	C4, C10, C12, C28, C31, C32, C15, C16, C26, C39	0.1 $\mu\text{f}$ 400 volt 20% molded tubular	10
12-132	C8, C24	6.8 $\mu\text{f}$ 10% ceramic disc	2
12-73	C3, C11, C20, C27	0.02 $\mu\text{f}$ 20% ceramic disc	4
12-106	C38a, C38b	60-60 $\mu\text{f}$ 250 volt electrolytic	1
12-107	C34a, b, c, d	270-100-100-100 $\mu\text{f}$ 75 volt electrolytic	1
12-108	C37a, C37b	20-200 $\mu\text{f}$ 250 volt electrolytic	1
12-109	C35	250 $\mu\text{f}$ 200 volt electrolytic (Insulated)	1
12-110	C36	250 $\mu\text{f}$ 200 volt electrolytic	1
12-111	C2, C19	0.04 $\mu\text{f}$ 200 volt molded tubular	2
12-112	C5, C21	680 $\mu\text{f}$ 10% ceramic disc	2
12-113	C6, C22	220 $\mu\text{f}$ 10% ceramic disc	2
12-114	C7, C23	0.15 $\mu\text{f}$ 200 volt 20% molded tubular	2
12-116	C13, C29	10 $\mu\text{f}$ 200 volt electrolytic	2
12-133	C14, C30	75 $\mu\text{f}$ 5% ceramic disc	2
12-131	C17, C33	4.7 $\mu\text{f}$ 10% ceramic disc	2
12-127	C9, C25	0.02 $\mu\text{f}$ ceramic disc $\pm 80$ -20%	2

<u>PART NO.</u>	<u>DESIGNATION</u>	<u>DESCRIPTION</u>	<u>QUANTITY</u>
<b>RESISTORS</b>			
13-1	R7, R9, R11, R15, R43, R45, R47, R51	100K ohm 1/2 watt 10%	8
13-2	R17, R53	22K ohm 1/2 watt 10%	2
13-3	R12, R48	2.2 Meg ohm 1/2 watt 10%	2
13-5	R6, R20, R42, R56	1.0 Meg ohm 1/2 watt 10%	4
13-16	R2, R38	470K ohm 1/2 watt 10%	2
13-17	R27, R29, R63, R65, R86	270K ohm 1/2 watt 10%	5
13-18	R84	4,700 ohm 1/2 watt 10%	1
13-19	R76	2,200 ohm 1/2 watt 10%	1
13-33	R19, R55, R75, R77, R36, R72	27K ohm 1/2 watt 10%	6
13-42	R32, R33, R68, R69	1K ohm 1/2 watt 10%	4
13-48	R3, R21, R39, R57	10K ohm 1/2 watt 10%	4
13-58	R1, R37	56K ohm 1/2 watt 10%	2
13-63	R4, R40	220K ohm 1/2 watt 5%	2
13-64	R85	8,200 ohm 1/2 watt 10%	1
13-79	R30, R31, R66, R67	18K ohm 1/2 watt 10%	4
13-101	R5, R41	2,700 ohm 1/2 watt 5%	2
13-102	R8, R44	1,200 ohm 1/2 watt 10%	2
13-103	R10, R46	330K ohm 1/2 watt 10%	2
13-104	R16, R52	820 ohm 1/2 watt 10%	2
13-106	R25, R26, R61, R62	15K ohm 1 watt 5%	4
13-107	R80	33 ohm 3 watt 10%	1
13-108	R82	450 ohm 7 watt 10%	1
13-109	R83	2,200 ohm 1 watt 10%	1
13-110	R87	5K ohm 20 watt 10%	1
13-111	R34, R35, R70, R71	10 ohm 1/2 watt 1%	4
13-118	R24, R60	330 ohm 1/2 watt 10%	2
13-116	R23, R59	560K ohm 1/2 watt 10%	2
13-117	R88, R89	680K ohm 1/2 watt 10%	2
13-121	R90, R91	470 ohm 2 watt 10%	2
13-288	R22, R58	91K ohm 1 watt 5%	2

#### SWITCHES AND CONTROLS

11-34	R28, R64, R79, R81	Concentric bias-balance control, (5K ohm - 10K ohm)	2
11-35	S6, R73, R74	Separation control and on/off switch, (dual 0.5 Meg ohm with SPST switch)	1
11-36	R13, R49	Concentric treble control (dual 0.5 Meg ohm)	1
11-37	R14, R50	Concentric bass control (dual 1.0 Meg ohm)	1
11-38	R18, R54	Clutch-operated volume-balance Control (dual 0.5 Meg ohm)	1
11-39	R78	Hum balance control (200 ohm 2 watt)	1
14-16/C	S2, S3	A and B slide switch (SPDT) -white	2
14-17/C	S5	Phase switch (DPDT) -white	1
14-23/C	S4a, S4b	Loudness switch (DPST) -white	1
14-24	S1a, S1b, S1c, S1d	Selector switch	1

#### TRANSFORMERS AND RECTIFIERS

15-19	T1	AC power transformer	1
15-22/A	T2, T3	Output transformer	2
17-9	SR1, SR2	Silicon diode	2
17-10	SR3	Silicon diode	1

<u>PART NO.</u>	<u>DESIGNATION</u>	<u>DESCRIPTION</u>	<u>QUANTITY</u>
<b>TUBES</b>			
26-1	V1, V2, V6	12AX7	3
26-2	V3, V7	7199	2
26-3	V4, V5, V8, V9	6CW5/EL86	4
<b>KNOBS</b>			
18-72		Small diameter outer knob (bass, treble and volume balance)	3
18-71		Large diameter panel knob (bass, treble and volume balance)	3
18-73		Single knob (selector and separation)	2
<b>MISCELLANEOUS</b>			
20-306	PL1	Neon pilot lamp assembly	1
20-316		Clip for pilot lamp	1
19-30		Tube sockets, V1, V2, V6	3
19-31		Tube sockets, V3, V4, V5, V7, V8, V9	6
20-173		V1, V2, V6 tube shields	3
19-4		AC receptacle	1
20-3		Wire strain relief	1
20-175		Fuse holder	1
20-186	F1	Fuse, 4 amp.	1
20-199		6' AC line cord with plug	1
20-77		Loudspeaker terminal strip (5 screws)	1
20-170		Loudspeaker terminal strip (4 screws)	1
19-29	J1, J9, J7, J8, J4, J10, J11, J12	Phono jack assembly (4 jacks)	2
20-169		Insulator for 4 phono jack assembly	2
19-22	J2, J3, J5, J6	Phono jack assembly (2 jacks)	2
20-79		Insulator for 2 phono jack assembly	2
19-3	J13	Single phono jack	1
20-164		4-lug terminal post	1
20-165		5-lug terminal post	1
20-167		7-lug terminal post	1
20-168		7-lug terminal post	1
20-10		2-lug terminal post	3
20-74		1-lug terminal post	1
20-42		1-lug terminal post	2
20-49		8-lug terminal post	2
20-78		3-lug terminal post	3
20-92		3-lug terminal post	1
20-73		3-lug terminal post	1
20-33		Grommet, for 1/2" chassis hole	4
20-25		Grommet, for 5/16" chassis hole	3
20-171		Grommet, for 3/8" chassis hole	3
16-2		Printed circuit (tone control circuit)	2
20-15		Capacitor mounting wafer	2
20-120		Spade lug	1
20-51		Cable strap	2
<b>CABINET PARTS</b>			
10-73D		Escutcheon	1
10-74		Front plate	1
10-200		Bottom plate	1

<u>PART NO.</u>	<u>DESIGNATION</u>	<u>DESCRIPTION</u>	<u>QUANTITY</u>
10-76B		Cage (Cover)	1
10-78A		Chassis	1
10-77		Shield bracket	1
20-341		Molded legs	4

#### HARDWARE

22-10		4-40 x 1/4" steel machine screw	86
22-11		6-32 x 1/4" steel machine screw	4
22-14		4-40 x 1/4" hex nut	90
22-16		#4 internal tooth lockwasher	90
22-17		#6 internal tooth lockwasher	4
22-19		6-32 x 5/16" hex nut	4
22-20		3/8"-32 hex nut	7
22-21		3/8" internal tooth lockwasher	6
22-26		8-32 x 11/32" hex nut	4
22-28		#8 internal tooth lockwasher	4
22-178		#8 x 3/8 PK screw	4
22-54		8-32 x 1-1/4" steel machine screw	4
22-85		8-32 x 1" steel machine screw	4
22-59		#8 x 1/2" flat washer	4
22-176		#6 x 3/8 PK screw	4
22-80/A		#8 x 1/2 PK screw	6
22-97		3/8" lockwasher (small pattern)	1

#### CABLES, LEADS AND SLEEVING

21-12		#22 Green Lead	5 feet
21-14		#22 Blue Lead	9 feet
21-15		#22 Black Lead	18 feet
21-16		#22 Red Lead	4 feet
21-17		Bare Wire #22	6 feet
21-25		#22 Red/White Lead	2 feet
21-26		#22 Green/White Lead	6 feet
21-27		#22 Blue/White Lead	11 feet
21-28		#22 Yellow/White Lead	5 feet
21-19		#14 sleeving	5 feet
21-44		2 Cond. Grey/Red Shielded Cable (Black, White inner leads)	2 feet
21-46		3 Cond. Grey/Black Shielded Cable (Brown, Yellow, Orange inner leads)	2 feet
21-47		4 Cond. Grey Cable (Brown, White, Black, Red inner leads)	2-1/2 feet
21-48		Single Cond. Blue Shielded Cable (Blue inner lead)	4 feet
21-49		Single Cond. Green Shielded Cable (Green inner lead)	4 feet
21-50		2 Cond. Grey/Blue Shielded Cable (Black, White inner leads)	2 feet
21-54		3 Cond. Grey Shielded Cable (Brown, Yellow, Orange inner leads)	2 feet
20-104/A		15 ft. roll solder	1

## RESISTORS AND CAPACITORS

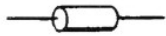

1/2 WATT  
RESISTOR



1/2 WATT  
1% RESISTOR



1 WATT RESISTOR



3 WATT RESISTOR

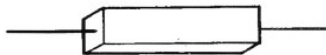

7 WATT RESISTOR

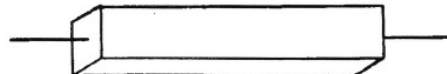

20 WATT RESISTOR

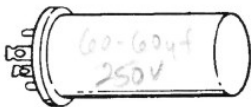

12-106  
ELECTROLYTIC  
CAPACITOR

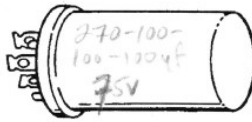

12-107  
ELECTROLYTIC  
CAPACITOR

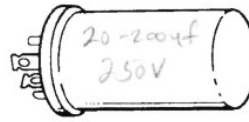

12-108  
ELECTROLYTIC  
CAPACITOR

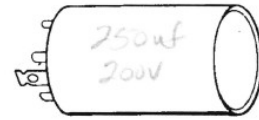

12-109  
ELECTROLYTIC  
CAPACITOR

12-110  
ELECTROLYTIC  
CAPACITOR

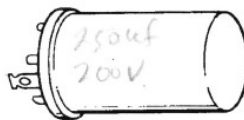

MOLDED  
TUBULAR CAPACITOR



CERAMIC  
DISC  
CAPACITOR

## SWITCHES AND CONTROLS

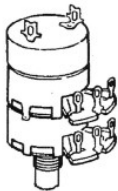

11-35  
SEPARATION  
CONTROL

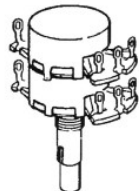

11-38 }  
11-37 } \*  
11-36 }  
DUAL  
CONCENTRIC  
CONTROL

\* These controls may be identified by referring to the part number which appears on the components



11-34  
CONCENTRIC  
BIAS-BALANCE  
CONTROL

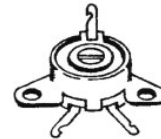

11-39  
HUM BALANCE  
CONTROL

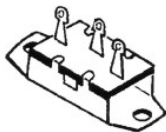

14-16  
S2, S3  
SLIDE SWITCH

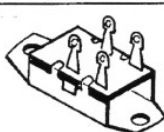

14-23  
S4  
SLIDE SWITCH



14-17  
S5  
SLIDE SWITCH

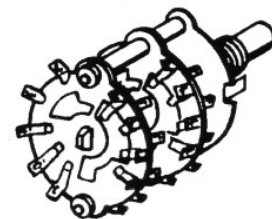

14-24  
SELECTOR  
SWITCH

### TRANSFORMERS AND RECTIFIERS

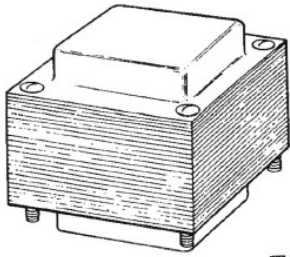

15-19  
T1  
POWER  
TRANSFORMER

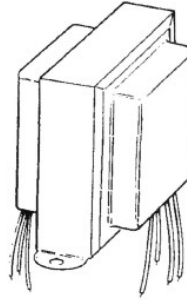

15-22/A  
T2, T3  
OUTPUT  
TRANSFORMER



17-9 17-10  
SILICON DIODE

### MISCELLANEOUS

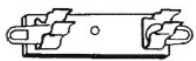

20-175  
FUSEHOLDER



20-51  
CABLE  
STRAP

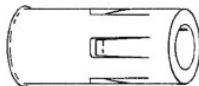

20-173  
TUBE  
SHIELD

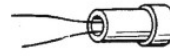

20-306  
NEON PILOT  
LAMP

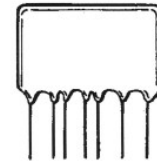

16-2  
PC  
BOARD



20-15  
CAPACITOR  
MOUNTING  
WAFER



20-3  
WIRE  
STRAIN  
RELIEF



20-341  
MOLDED  
LEG



20-316  
CLIP

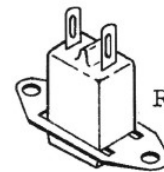

19-4  
AC  
RECEPTACLE

### HARDWARE



22-10  
4-40 x 1/4"  
SCREW



22-16  
#4  
LOCKWASHER



22-14  
4-40 x 1/4"  
HEX NUT



22-26  
8-32  
HEX NUT



22-97  
3/8" LOCKWASHER  
(Small Pattern)



22-11  
6-32 x 1/4"  
SCREW



22-17  
#6  
LOCKWASHER



22-19  
6-32 x 5/16"  
HEX NUT



22-28  
#8  
LOCKWASHER



22-21  
3/8"  
LOCKWASHER



22-20  
3/8" - 32  
HEX NUT



8-32 SCREW  
22-85 1"  
22-54 1-1/4"



22-59  
#8 x 1/2"  
FLAT  
WASHER



22-178  
#8 x 3/8"  
PK SCREW



22-80/A  
#8 x 1/2"  
PK SCREW



22-176  
#6 x 3/8"  
PK SCREW



20-120  
SPADE  
LUG

## TERMINAL POSTS



20-42



20-74



20-10



20-73

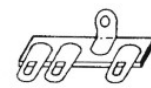

20-78

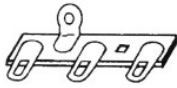

20-92



20-164

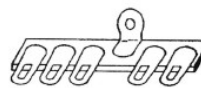

20-165



20-167



20-168



20-49

## JACKS, TERMINAL STRIPS AND SOCKETS

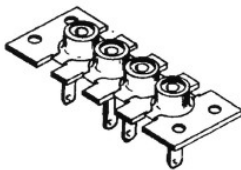

19-29  
4-PHONO JACK

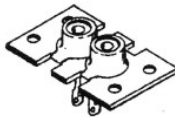

19-22  
2-PHONO JACK



19-3  
SINGLE  
PHONO JACK

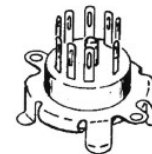

19-30  
TUBE  
SOCKET



20-169  
INSULATOR  
FOR 19-29

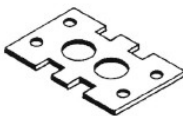

20-79  
INSULATOR  
FOR 19-22

19-31  
TUBE  
SOCKET

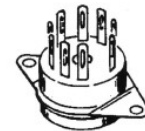

20-77  
5-LUG  
TERMINAL  
STRIP

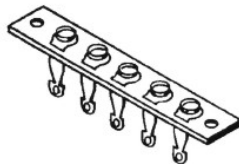

20-170  
4-LUG  
TERMINAL  
STRIP

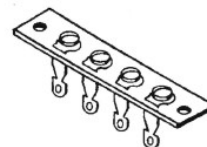

## TOOLS YOU WILL NEED

Just a few standard tools are all you will need to successfully assemble this kit. You should use a small iron (about 25 to 50 watts) for soldering. A pair of long-nose pliers; a pair of diagonal or side-cutting pliers; a small screwdriver and a small adjustable wrench complete your tool requirements; an ohmmeter such as the Lafayette TE-10 or RW-60 would be of value.

## STEP-BY-STEP INSTRUCTIONS

The instructions which follow have been carefully planned and arranged in the most logical and practical sequence possible. Skilled engineers and technical writers have prepared these instructions while actually assembling samples of this kit. We are certain we have provided you with the best and fastest method of assembling your kit.

Each instructional step should be read and thoroughly understood before it is performed. In this way, errors will be avoided. Check off each step in the check space ( ) provided. In this way you will avoid omitting any steps. You might also use a colored pencil to cross out each wire and component on the wiring pictorials after insertion.

Assembly and wiring pictorials have been provided to assist you in following the step-by-step instructions. All components have been assigned letter and/or number designations. Those components which also appear on the schematic diagram have generally been assigned the same designations on the wiring pictorials. Other components, such as terminal strips, solder lugs, etc. have been assigned letter and/or number designations.

The instructions tell you when to solder and when not to solder a connection. When you see "No Solder" (NS) after or during a step, simply wrap or "crimp" the lead to the terminal and proceed to the next step. When all leads have been connected to this terminal, a solder designation (S) will follow. The figures which appear with these designations indicate the number of connections which have been made to that terminal or lug when the "Solder" instruction is given.

## READ CAREFULLY BEFORE PROCEEDING

### NOTES ON WIRING

Each kit is supplied with more than enough hook-up wire for complete wiring. A length of insulated hook-up wire, unless otherwise specified, should have about 1/4" of insulation removed or "stripped" from each end. Excessive wire exposure increases the possibility of shorts to nearby wiring or terminals. Use a razor blade or sharp knife to cut off the insulation; during this operation, be sure not to cut into the wire itself. The length to which each hook-up wire is to be cut is specified in the step-by-step instructions, and allowance has been made for the removal of the insulation from each end. The hook-up wire supplied is solid wire, but some of the transformer leads are stranded; the latter should be tinned (coated with solder) before connecting to the specified point. To prepare these transformer leads, remove a 1/4" length of insulation from the end of the lead, twist all the strands together with your fingers, and tin the end. To connect a wire to a lug as specified in the step-by-step instructions, put about three-quarters of the bared end of the wire through the hole in the lug, and then, using the long-nose pliers, wrap the wire around the lug.

### NOTES ON SOLDERING

The importance of good soldering technique in the construction of kits cannot be over-emphasized. Good solder joints are essential if you are to realize the quality and stability of performance that has been engineered into this unit. If you are inexperienced in soldering, we suggest that you spend a little time practicing with pieces of scrap wire and an old tube socket or terminal strip before attempting to do any soldering on your kit. The purpose of soldering an electrical connection is to provide a permanent electrical bond between the wires and terminals to be joined. This prevents the formation of corrosion which insulates or produces unwanted resistance between the joined parts. It is not at all difficult to make a good solder connection that will provide the required electrical bond if you will simply observe a few basic rules for good soldering.

1. Use only good quality, rosin-core solder made specifically for radio and television use; a good composition is 60 per cent tin and 40 per cent lead (usually indicated as 60/40). Acid core solder or paste flux must NOT, under any circumstances, be used, as the corrosive effects of these materials will cause much damage to the circuit components.

## CAUTION

THE USE OF ACID CORE SOLDER OR PASTE FLUX ON THIS KIT OR ANY PORTION THEREOF AUTOMATICALLY VOIDS OUR WARRANTY COVERAGE.

2. Use a good soldering iron, 25-50 watts. The tip of the iron must be kept clean and well tinned, in accordance with the instructions of the soldering iron manufacturer, to obtain consistently good connections. The tip should present a bright appearance and be free of excess solder. An old rag or a pad of steel wool may be used to wipe the hot tip clean occasionally during use.
3. Be sure leads and terminals to be joined are clean and free of wax or corrosion before soldering. The solder will not adhere properly to the joint if the leads and terminals are dirty or corroded. This will usually result in a "cold" or high resistance connection.
4. A good mechanical connection should always be made before soldering, by crimping the leads on the terminals with your pliers. Do not rely on solder alone for physical strength. Stranded hook-up wire should always be tinned with solder before being connected.
5. To solder properly, apply the iron to the joint for a few seconds; then apply the solder and hold the iron on the connection until the solder flows freely. The solder must flow completely over the connection. Simply melting drops of solder onto the connection will not produce the desired results, but will result in a "cold" solder connection. This presents a dull and pitted or "grainy" appearance. A good connection will have a smooth and shiny appearance. Remember, the joint itself must be heated sufficiently to melt solder before the solder will flow smoothly and freely in and around the connection; however, you must be careful not to apply heat too long. Excessive heat from the iron may damage components and insulation on wires connected to the joint. When soldering a joint having a small component connected to it (a 1/2 watt resistor, for example) the component may be protected from excessive heat from the iron by grasping the lead between the joint and the component with long-nose pliers. The pliers will then conduct most of the heat away from the component, preventing overheating. Do not use too much solder when making a connection. Use only enough to completely cover all leads and to fill lug or terminal holes. Excessive use of solder may result in the formation of solder "bridges" or shorts between adjacent terminals or nearby wiring, particularly on tube sockets and switch terminals. Also, solder may flow into the switch contacts, destroying switch action.

## MECHANICAL ASSEMBLY

To assist you in assembling this kit, mechanical assembly views are shown which supplement the step-by-step instructions. In order to clarify the drawings, not all the mounting hardware is shown. The amount of hardware used to assemble each part is specified in the step-by-step instructions.

NOTE: 4-40 Hardware (2) means to use two 4-40 x 1/4" screws, two #4 lockwashers, and two 4-40 x 1/4" hex nuts to mount the part.

## COMPONENT MOUNTING—MAIN CHASSIS

Refer to Pictorials 1, 2 and 3, Figures 1, 2.

1. ( ) Select the main chassis (part #10-78). Mount the AC Receptacle (part #19-4) and the 1-lug terminal post TP-1 (part #20-74) at hole A, using 4-40 hardware (2). See Figure 1 on page 12 and Pictorial 3.
2. ( ) Mount the 4-terminal speaker strip TS-1 (part #20-170) at hole C. Observe the location of the solder lugs which should be nearest the open side of the chassis. Use 4-40 hardware (2). See Pictorials 2 and 3.

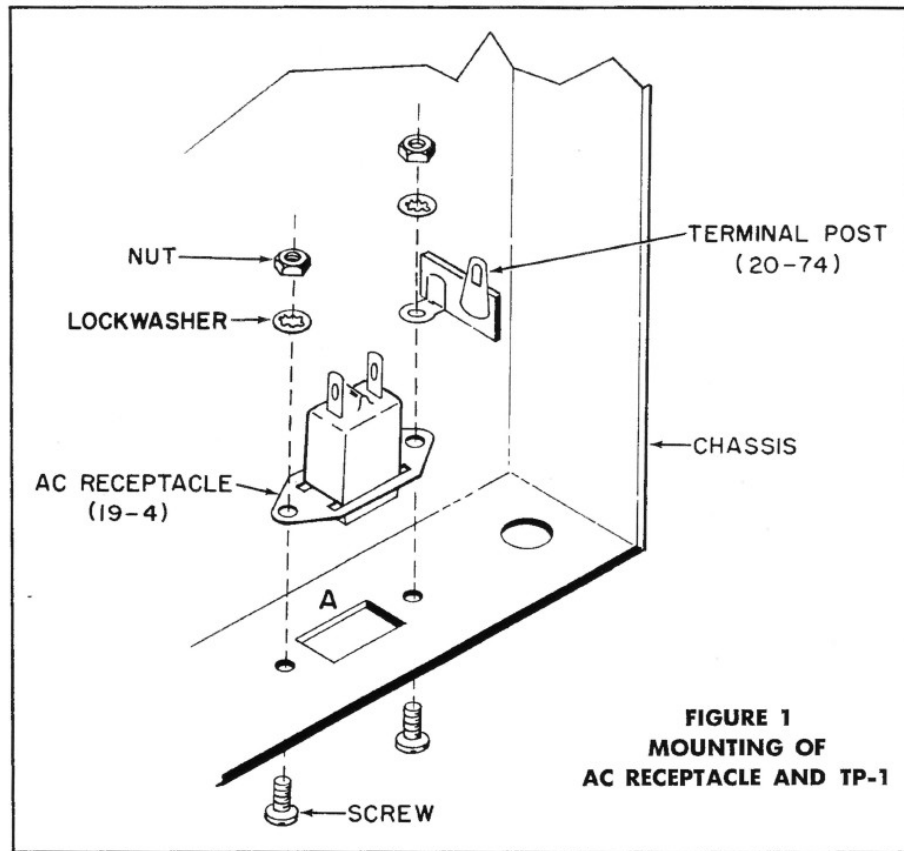

#### COMPONENT MOUNTING - MAIN CHASSIS

- 3.( ) Similarly, mount the 5-terminal speaker strip TS-2 (part #20-77) at hole B. Use 4-40 hardware (2).
- 4.( ) Mount the single phono jack J13 (part #19-3) at hole D, using 4-40 hardware (2). See Pictorials 1 and 3.
- 5.( ) Mount three 5/16" rubber grommets (part #20-25) at holes E, N and X. See Pictorial 2 which shows the mounting of one of these grommets at hole E.
- 6.( ) Select the hum balance control, R78, (part #11-39). Using a pair of long nose pliers, bend the center lug up as shown in Pictorial 3. Mount the control at hole E, using 4-40 hardware (2). Bend the other two solder lugs away from the chassis.
- 7.( ) Select the phono jack assembly (4-jacks), part #19-29 (J4, J10, J11, J12), and the insulator (part #20-169). Mount both at hole F using (4) 4-40 screws and (4) 4-40 nuts. Note the location of the double ground lug - see Pictorial 1 and Figure 2.
- 8.( ) Similarly, mount the phono jack assembly (4-jacks), part #19-29 (J1, J7, J8, J9), and the insulator (part #20-169) at hole G using (4) 4-40 screws and (4) 4-40 nuts. Note the location of the double ground lug.
- 9.( ) Select the dual phono jack assembly (part #19-22) J5, J6, and the insulator (part #20-79). Mount both at hole H using (4) 4-40 screws and (4) 4-40 nuts. See Pictorial 1 and Figure 2.
- 10.( ) Select the dual phono jack assembly (part #19-22) J2, J3, and the insulator (part #20-79). Mount both at hole I using (4) 4-40 screws and (4) 4-40 nuts. Mount as shown in Figure 2.
- 11.( ) Select four 1/2" rubber grommets (part #20-33) and mount them at holes J, K, L and M. See Pictorials 1 and 2.
- 12.( ) Mount the 3-lug terminal post TP-2 (part #20-92) at hole P, using 4-40 hardware (1). Refer to Pictorials 1 and 3.
- 13.( ) Mount the fuse holder (part #20-175) at hole Q, using (1) 4-40 screw and (1) 4-40 nut. Refer to Pictorials 1 and 3.

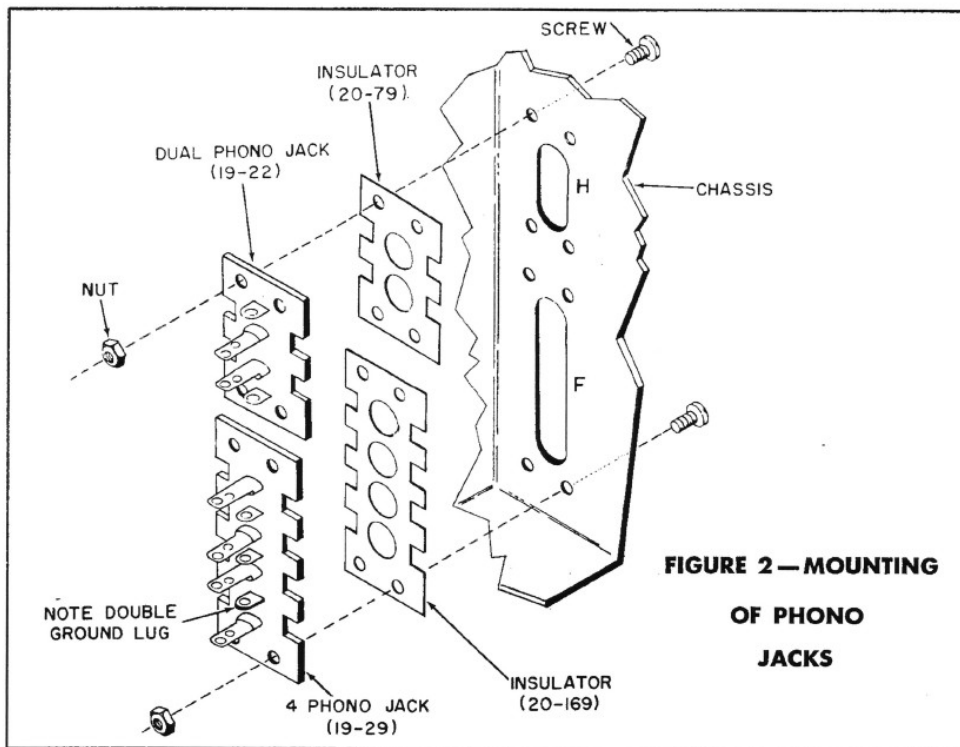



- 14.( ) Mount the V9 tube socket (part #19-31) at hole S using 4-40 hardware (2). Observe the location of the blank space between pins in Pictorial 3. Mount as shown in Pictorial 2, from the topside of the chassis.
  - 15.( ) Similarly, mount the V8, V4 and V5 tube sockets (part #19-31) at holes R, T and U respectively, using 4-40 hardware (2) in each case. Observe the location of the blank space between pins in Pictorial 3.
  - 16.( ) Mount a capacitor mounting wafer (part #20-15) on the topside of the chassis at hole W, using 4-40 hardware (2). Mount a cable strap (part #20-51) under one lockwasher and nut as shown in Pictorial 2. Adjust the wafer opening so that it is located centrally in the chassis hole.
  - 17.( ) Mount another wafer at hole V, using 4-40 hardware (2).
  - 18.( ) Mount two 1-lug terminal posts, TP-3, TP-4 (part #20-42) on the underside of the chassis at holes Y and Z. Use 4-40 hardware (1) for each. See Pictorials 1 and 3.
  - 19.( ) Mount a 7-lug terminal post, TP-5 (part #20-167) on the underside of the chassis at holes AA, using 4-40 hardware (2).
  - 20.( ) Mount an 8-lug terminal post, TP-6 (part #20-49) on the underside of the chassis at holes BB, using 4-40 hardware (2).
  - 21.( ) Mount an 8-lug terminal post, TP-7 (part #20-49) on the underside of the chassis at holes CC, using 4-40 hardware (2).
  - 22.( ) Mount the dual bias-balance control, R64-R81 (part #11-34) on the underside of the chassis at hole EE, using a 3/8-32 hex nut and 3/8 lockwasher as shown in Pictorial 2. Make sure the locating lug enters the small hole provided for it.
- NOTE:** One of the seven 3/8" lockwashers supplied has a smaller outside diameter and is thinner than the others. This small pattern lockwasher should only be used for mounting the selector switch (in step 247). Use the regular 3/8" type for the other controls (including R64 - 81 above).
- 23.( ) Similarly, mount the dual bias-balance control R28-R79 (part #11-34) at hole DD.

### COMPONENT MOUNTING - MAIN CHASSIS

- 24.( ) Mount the three 3/8" rubber grommets (part #20-171) at holes KK.
- 25.( ) Mount the front plate (part #10-74) onto the chassis as shown in Pictorial 2. Use 4-40 hardware (3) at holes FF.
- 26.( ) Mount the Phase switch, S5 (part #14-17/C) at hole JJ, using 4-40 hardware (2). See Pictorials 1 and 3.
- 27.( ) Mount the Loudness switch, S4 (part #14-23/C) at hole II, using 4-40 hardware (2). Orient as shown in Pictorial 3.
- 28.( ) Mount the B Amplifier switch, S3 (part #14-16/C) at hole HH, using 4-40 hardware (2). Orient as shown.
- 29.( ) Mount the A Amplifier switch, S2 (part #14-16/C) at hole GG, using 4-40 hardware (2). Orient as shown.
- 30.( ) Mount a 7-lug terminal post, TP-8 (part #20-168) on the underside of the chassis at holes LL, using 4-40 hardware (2). Orient as shown in Pictorial 3.
- 31.( ) Mount the V2 tube socket (part #19-30) from the topside of the chassis at hole MM, using 4-40 hardware (2). See Pictorial 2. Orient pins as shown in Pictorial 3.
- 32.( ) Similarly, mount the V1 tube socket (part #19-30) at hole OO, using 4-40 hardware (2). Orient pins as shown in Pictorial 3.
- 33.( ) Similarly, mount the V6 tube socket (part #19-30) at hole QQ, using 4-40 hardware (2). Orient pins as shown in Pictorial 3.
- 34.( ) Similarly, mount the V7 tube socket (part #19-31) at hole NN, using 4-40 hardware (2). Orient pins as shown in Pictorial 3.
- 35.( ) Similarly, mount the V3 tube socket (part #19-31) at hole PP, using 4-40 hardware (2). Orient pins as shown in Pictorial 3.
- 36.( ) Mount the 3-lug terminal post, TP-9 (part #20-78) on the underside of the chassis at hole RR, using 4-40 hardware (1). Orient as shown in Pictorial 3.
- 37.( ) Mount the 3-lug terminal post, TP-10 (part #20-73) on the underside of the chassis at holes SS, using 4-40 hardware (2).
- 38.( ) Mount the 2-lug terminal post, TP-11 (part #20-10) at hole TT, using 4-40 hardware (1).
- 39.( ) Mount the 5-lug terminal post, TP-12 (part #20-165) at hole UU, using 4-40 hardware (1).
- 40.( ) Mount the 3-lug terminal post, TP-13 (part #20-78) at hole VV, using 4-40 hardware (1).
- 41.( ) Mount the 3-lug terminal post, TP-14 (part 20-78) at hole WW, using 4-40 hardware (1).
- 42.( ) Mount the 4-lug terminal post, TP-17 (part #20-164) on the topside of the chassis at hole XX, using 4-40 hardware (1). Mount the cable strap (part #20-51) under the lockwasher and nut as shown in Pictorial 2.
- 43.( ) Mount the 2-lug terminal post, TP-16 (part #20-10) on the topside of the chassis at hole YY, using 4-40 hardware (1). See Pictorial 2.
- 44.( ) Mount the 2-lug terminal post, TP-15 (part #20-10) on the topside of the chassis at hole ZZ, using 4-40 hardware (1).

## COMPONENT MOUNTING - MAIN CHASSIS

- 45.( ) Mount a 250 $\mu$ f 200 volt electrolytic capacitor, C35 (part #12-109) on insulation wafer at V as shown in Pictorial 2. Orient solder lug as shown in Pictorial 3, with the mounting lugs protruding through the slots in the wafer. To mount securely, hold the capacitor firmly against the wafer and twist each of the four mounting lugs 1/4 turn, using pliers. Make sure the capacitor used is the one with insulation covering.
- 46.( ) Similarly, mount a 250 $\mu$ f 200 volt electrolytic capacitor, C36 (part #12-110) on insulation wafer at hole W. Orient solder lug as shown in Pictorial 3. Twist mounting lugs to secure the capacitor.
- 47.( ) Mount a 20/200 $\mu$ f 250 volt electrolytic capacitor, C37 (part #12-108) at hole AB, with the mounting lugs protruding through the slots in the chassis. Orient solder lugs as shown in Pictorial 3. Twist the mounting lugs to secure the capacitor to the chassis.
- 48.( ) Similarly, mount a 60/60 $\mu$ f 250 volt electrolytic capacitor, C38 (part #12-106) in hole AC. Orient solder lugs as shown in Pictorial 3. Twist the mounting lugs to secure the capacitor to chassis.
- 49.( ) Similarly, mount a 270/100/100/100 $\mu$ f 75 volt electrolytic capacitor, C34 (part #12-107) in hole AD. Orient solder lugs as shown in Pictorial 3, observing the location of the , , and  markings. Twist mounting lugs to secure capacitor to the chassis.
- 49a ( ) Solder one of the twisted mounting lugs of C38 and C34 as indicated in Pictorial 3. Use sufficient Solder and heat to make a good electrical connection between each lug and chassis.
- 50.( ) Mount the Separation control, R73-R74-S6, (part #11-35) at hole AE, using a 3/8 hex nut and lockwasher as shown in Pictorial 2. Make sure the locating tab enters the special hole provided.
- 51.( ) Similarly, mount the Volume-Balance control, R18-R54 (part #11-38) at hole AF. Use a 3/8 hex nut and lockwasher.
- 52.( ) Similarly, mount the Treble control, R13-R49 (part #11-36) at hole AG. Use a 3/8 hex nut and lockwasher.
- 53.( ) Similarly, mount the Bass control, R14-R50 (part #11-37) at hole AH. Use a 3/8 hex nut and lockwasher.
- 54.( ) Mount the output transformer T2 (part #15-22/A) on the topside of the chassis at holes AM, using two 6-32 x 1/4 screws, two #6 lockwashers and two 6-32 hex nuts. Each group of leads should be twisted to facilitate entry into the two grommet holes (L and M) provided. Orient the transformer as shown in Pictorial 2, with the blue, red and blue/white leads on the left-hand side (into hole M).
- 55.( ) In the same manner, mount the output transformer T3 (part #15-22/A) at holes AN, using two 6-32 x 1/4 screws, two #6 lockwashers and two 6-32 hex nuts. Orient the transformer with the blue, red and blue/white leads on the left-hand side. Feed the leads through grommet holes K and J. Refer to Pictorial 1 for hole locations
- 56.( ) Mount the AC power transformer T1 (part #15-19) on the topside of the chassis at hole AL, using four 8-32 x 11/32 hex nuts and four #8 lockwashers. Orient the transformer with the leads in the position shown in Pictorial 3.
- 57.( ) Mount the shield bracket (part #10-77) at holes AR, using 4-40 hardware (2). See Pictorial 3.

Note: The Selector Switch (14-24) shown in Pictorial 2, is not mounted at this time. Instructions to do so will be given later in the manual (after switch has been prewired). At that time, reference should be made to this pictorial for method of mounting.

This completes the mounting of main chassis components. Pictorials 1 and 2 may now be put aside, as they will no longer be required.

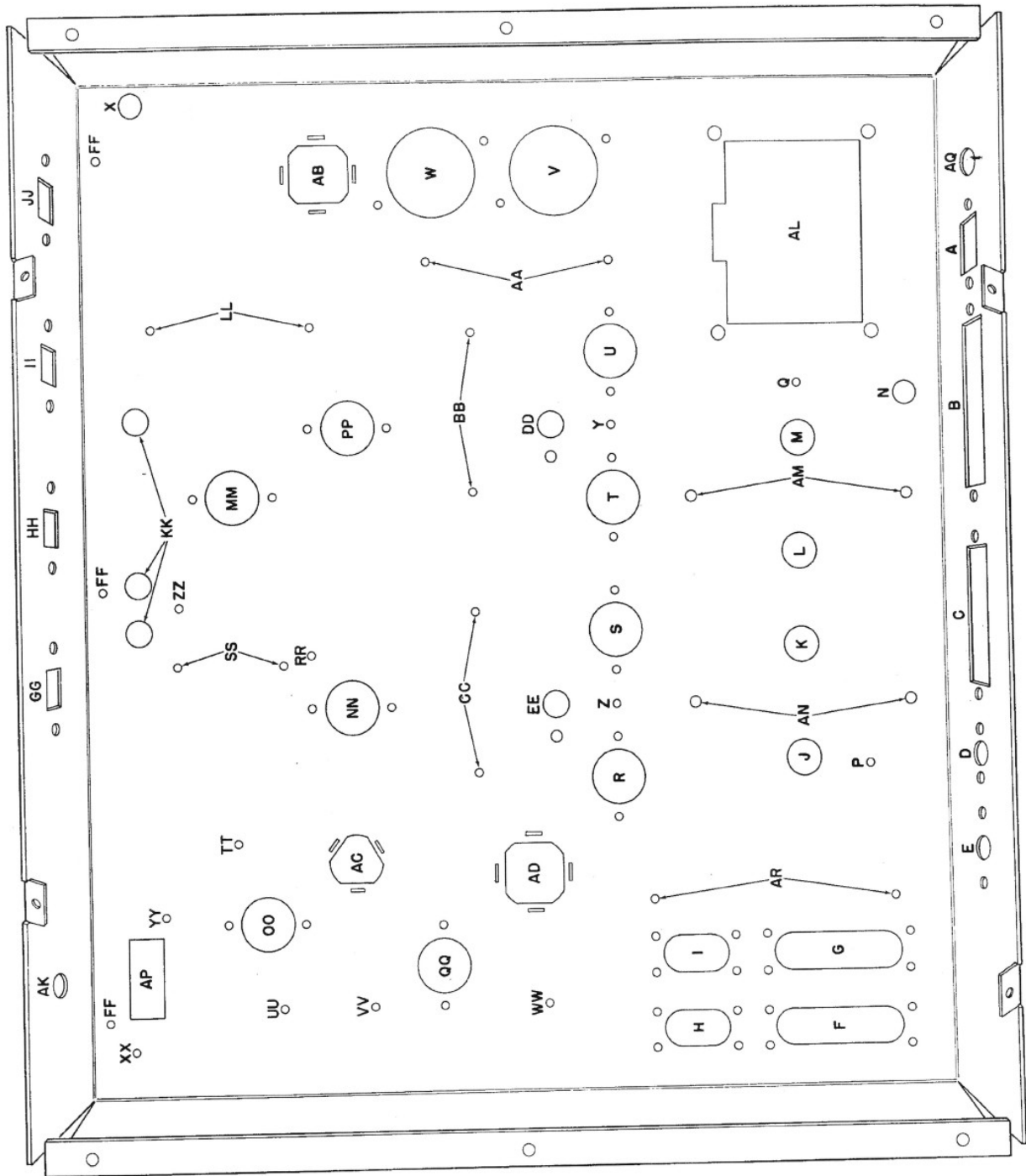

**PICTORIAL 1**  
**MAIN CHASSIS HOLE DESIGNATIONS**

**PICTORIAL 2  
COMPONENT MOUNTING —  
TOP CHASSIS VIEW**

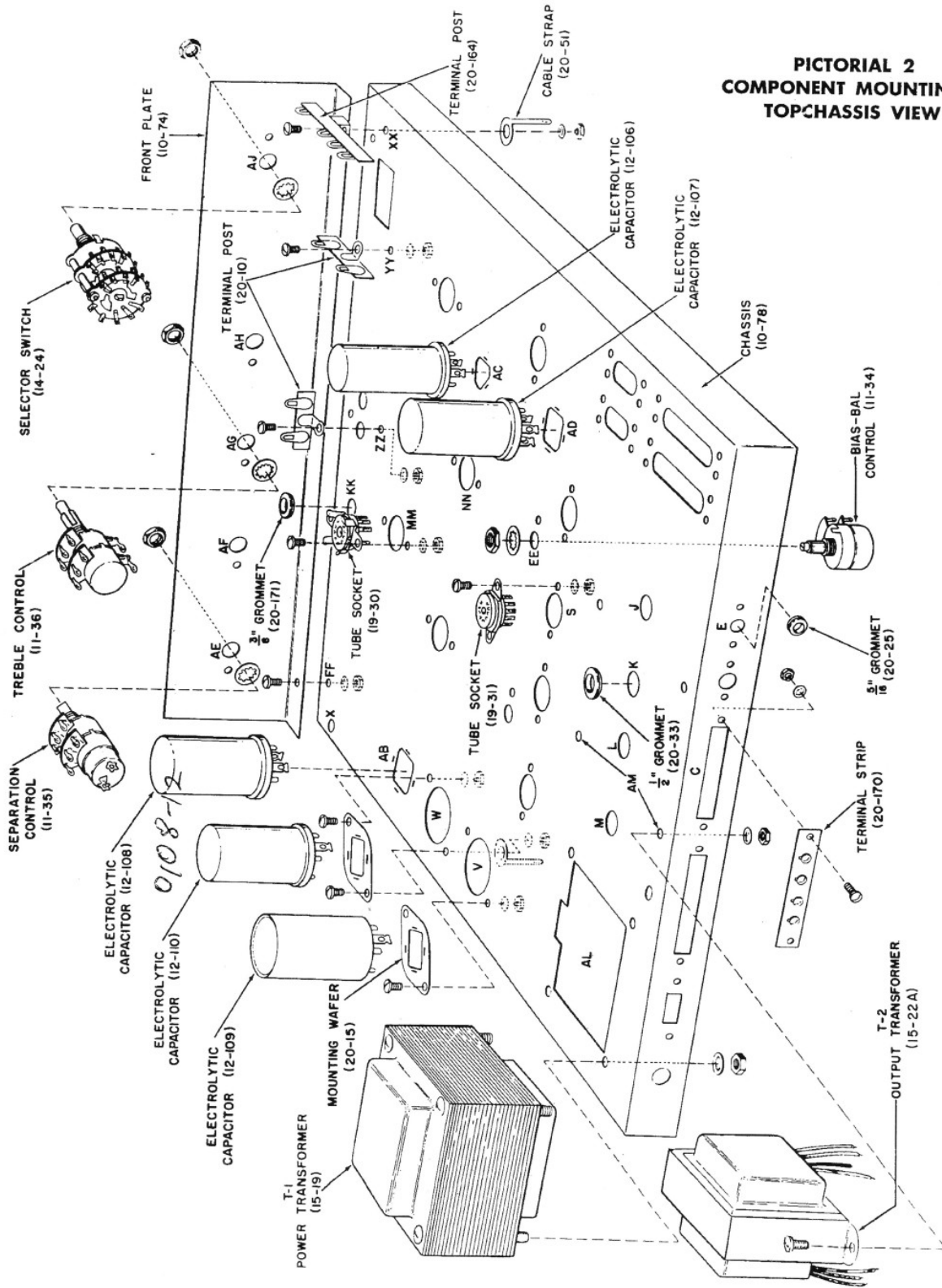

**PICTORIAL 3**  
**COMPONENT MOUNTING — UNDERCHASSIS VIEW**

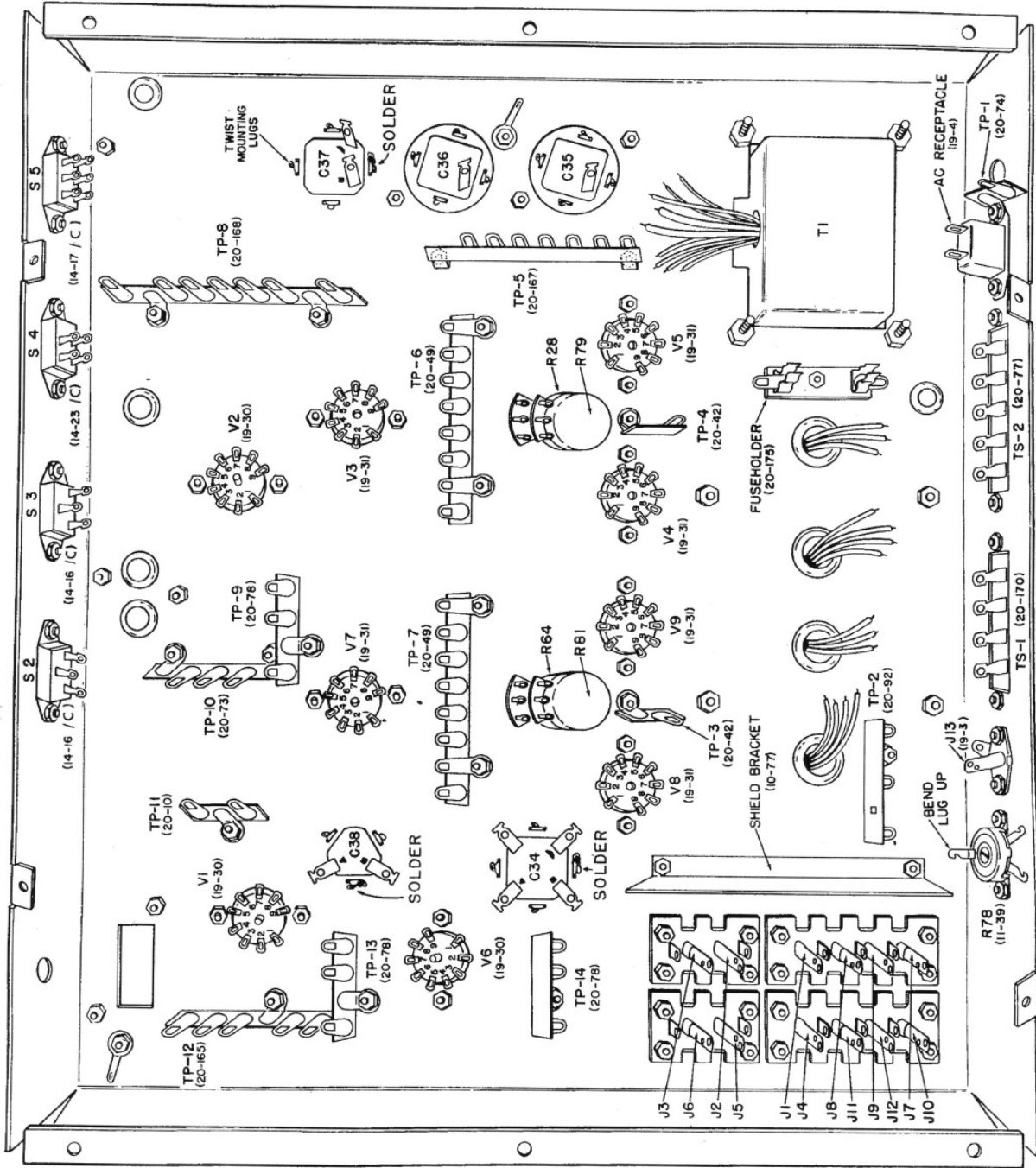

## WIRING

### REFER TO PICTORIAL 4

- 1.( ) Connect an 8-1/2" length of blue/white lead from TS-2 lug 4 (NS) to TP-2 lug 3 (NS).
- 2.( ) Connect a 12-1/2" length of blue lead from TS-1 lug 1 (NS) to TP-9 lug 2 (NS).
- 3.( ) Connect the black transformer lead coming from grommet hole J to TS-1 lug 4 (NS).
- 4.( ) Connect the orange transformer lead coming from grommet hole J to TS-1 lug 3 (NS).
- 5.( ) Connect the green transformer lead coming from grommet hole J to TS-1 lug 2 (S-1).
- 6.( ) Cut 1" from the black transformer lead coming from grommet hole L. Strip 1/4" of insulation from the end and tin. Connect to TS-1 lug 4 (NS).
- 7.( ) Connect a 13" length of green lead from TS-2 lug 2 (NS) to TP-8 lug 6 (NS).
- 8.( ) Connect the yellow transformer lead coming from grommet hole L to TS-2 lug 2 (S-2).
- 9.( ) Connect the green transformer lead coming from grommet hole L to TS-2 lug 3 (S-1).
- 10.( ) Connect the yellow transformer lead from grommet hole J to TS-1 lug 1 (S-2).
- 10a ( ) Connect the orange transformer lead from grommet hole L to TS-2 lug 4 (S-2).
- 11.( ) Connect a 4" length of red lead from V9 pin 9 (NS) to V8 pin 9 (S-1).
- 12.( ) Connect a 4" length of red lead from V5 pin 9 (NS) to V4 pin 9 (S-1).
- 13.( ) Connect a 5-3/4" length of red lead from TP-5 lug 5 (NS) to TP-4 lug 1 (NS).
- 14.( ) Connect the short black lead from AC power transformer T1 to the fuseholder, lug 1 (S-1). Connect the longer black lead to the AC receptacle lug 2 (NS).
- 15.( ) Connect the white lead from T1 to TP-5 lug 1 (NS).
- 16.( ) Connect a 4-1/4" length of black lead from TP-5 lug 1 (NS) to C36 lug G1 (S-1). Dress the lead close to TP-5.
- 17.( ) Connect the red lead from T1 to TP-5 lug 4 (NS).
- 18.( ) Connect the red/white lead from T1 to C35 lug G1 (S-1).
- 19.( ) Connect a 4-1/4" length of red lead from TP-5 lug 7 (NS) to C35 lug 1 (NS).
- 20.( ) Connect a 2" length of red lead from C36 lug 1 (S-1) to C35 lug G2 (S-1).
- 21.( ) Twist together the two red transformer leads from grommet holes K and M as shown. Cut off any excess lead, strip 1/4" of insulation and tin the wire ends before connecting both ends to C35 lug 1 (NS).
- 22.( ) Twist together the green and yellow transformer leads from T1. Connect the green lead to TP-5 lug 2 (NS) and the yellow lead to TP-5 lug 3 (NS).
- 23.( ) Connect a 6-1/2" red lead from TP-5 lug 5 (NS) to C37 lug 2 (S-1). Dress exactly as shown.
- 24.( ) Cut each wire of a 33 ohm 3 watt resistor R80 to 7/8", and connect from C34 lug 3 (NS) to C34 lug 4 (NS).
- 25.( ) Connect a 5-1/4" length of yellow/white lead from TP-2 lug 1 (NS) to C34 lug 3 (S-2).
- 26.( ) Cut the brown and brown/white leads from T1 as follows:- brown/white - 11", brown - 10". Strip 1/4" of insulation from the ends and tin. Twist the leads as shown - approximately 8". Connect the shorter brown lead to TP-2 lug 2 (NS) and the longer brown/white lead to C34 lug G1 (NS).

## WIRING

- 27.( ) Bend out slightly the center lugs of the bias-balance controls R64-R81, R28-R79 (lugs 2).
- 28.( ) Connect a 5" length of blue lead from C34 lug 2 (S-1) to R64 lug 2 (NS). Slip one end of a 1-1/2" length of bare wire down through R81 lug 2 (NS) and connect to R64 lug 2 (S-2). Connect the free end to R81 lug 1 after cutting off any excess wire. Solder lug 1 and 2 of R81.
- 29.( ) Connect a 5-1/4" length of red lead from TP-3 lug 1 (NS) to TP-4 lug 1 (NS)
- 30.( ) Slip one end of a 1-1/2" length of bare wire down through R79 lug 2 and connect to R28 lug 2 (NS). Connect the free end to R79 lug 1 after cutting off any excess wire. Solder lug 1 and 2 of R79.
- 31.( ) Connect a 4" length of yellow/white lead from C34 lug 4 (NS) to R81 lug 3 (NS).
- 32.( ) Connect a 7" length of yellow/white lead from R81 lug 3 (S-2) to R79 lug 3 (S-1).
- 33.( ) Connect a 5-3/4" length of blue/white lead from TP-6 lug 4 (NS) to TP-7 lug 4 (NS).
- 34.( ) Connect a 10-1/2" length of black lead from TP-7 lug 5 (NS) to C37 lug G2 (NS). *- new lead cap*
- 35.( ) Connect a 10-3/4" length of yellow/white lead from C34 lug 4 (S-3) to V2 pin 5 (S-1).
- 36.( ) Connect a 5" length of blue/white lead from C37 lug 1 (NS) to TP-5 lug 6 (NS). *- new lead cap*
- 37.( ) Connect a 4-3/4" length of blue/white lead from TP-5 lug 6 (NS) to TP-6 lug 4 (NS).
- 38.( ) Connect a 6-1/4" length of black lead from TP-6 lug 5 (NS) to C37 lug G2 (NS). *- new lead cap*
- 39.( ) Cut a 1-1/2" length of bare wire. Connect from TP-6 lug 5 (NS) to TP-6 lug 6 (NS). Cut off any excess wire before crimping around lugs.
- 40.( ) Cut a 1-1/2" length of bare wire. Connect from TP-6 lug 3 (NS) to TP-6 lug 4 (NS). Cut off any excess wire before crimping around lugs.
- 41.( ) Cut a 1-1/2" length of bare wire. Connect from TP-7 lug 5 (NS) to TP-7 lug 6 (NS). Cut off any excess wire before crimping around lugs.
- 42.( ) Cut a 1-1/2" length of bare wire. Connect from TP-7 lug 3 (NS) to TP-7 lug 4 (NS). Cut off any excess wire before crimping around lugs.
- 43.( ) Connect a 7" length of yellow/white lead from V1 pin 5 (S-1) to V2 pin 4 (S-1).
- 44.( ) Connect a 5-3/4" length of yellow/white lead from V1 pin 4 (S-1) to V6 pin 5 (S-1).
- 45.( ) Connect a 2-3/4" length of yellow/white lead from C34 lug G1 (NS) to V6 pin 4 (S-1).
- 46.( ) Cut one lead of a 5000 ohm 20 watt resistor R87 to 5/8". Cut the other lead to 7/8". Connect the shorter lead to C37 lug G1 (S-1), the longer lead to TP-5 lug 5 (NS). *- new lead cap*
- 47.( ) Connect an 7-3/4" length of red/white lead from TP-8 lug 4 (NS) to TP-10 lug 1 (NS).
- 48.( ) Connect a 3" length of black lead from C37 lug G2 (S-3) to S5 lug 4 (NS). *> new lead cap*
- 49.( ) Connect a 2" length of bare wire from C37 lug G3 (S-1) to C36 lug G2 (S-1).
- 50.( ) Connect a 4-3/4" length of red/white lead from C38 lug 2 (NS) to TP-10 lug 1 (NS).
- 51.( ) Connect an 5-1/2" length of black lead from C38 lug G1 (NS) to TP-10 lug 2 (NS).
- 52.( ) Connect a 6-3/4" length of black lead from TP-10 lug 2 (NS) to TP-8 lug 1 (NS).
- 53.( ) Connect a 2-1/2" length of black lead from C38 lug G2 (NS) to TP-11 lug 2 (NS).

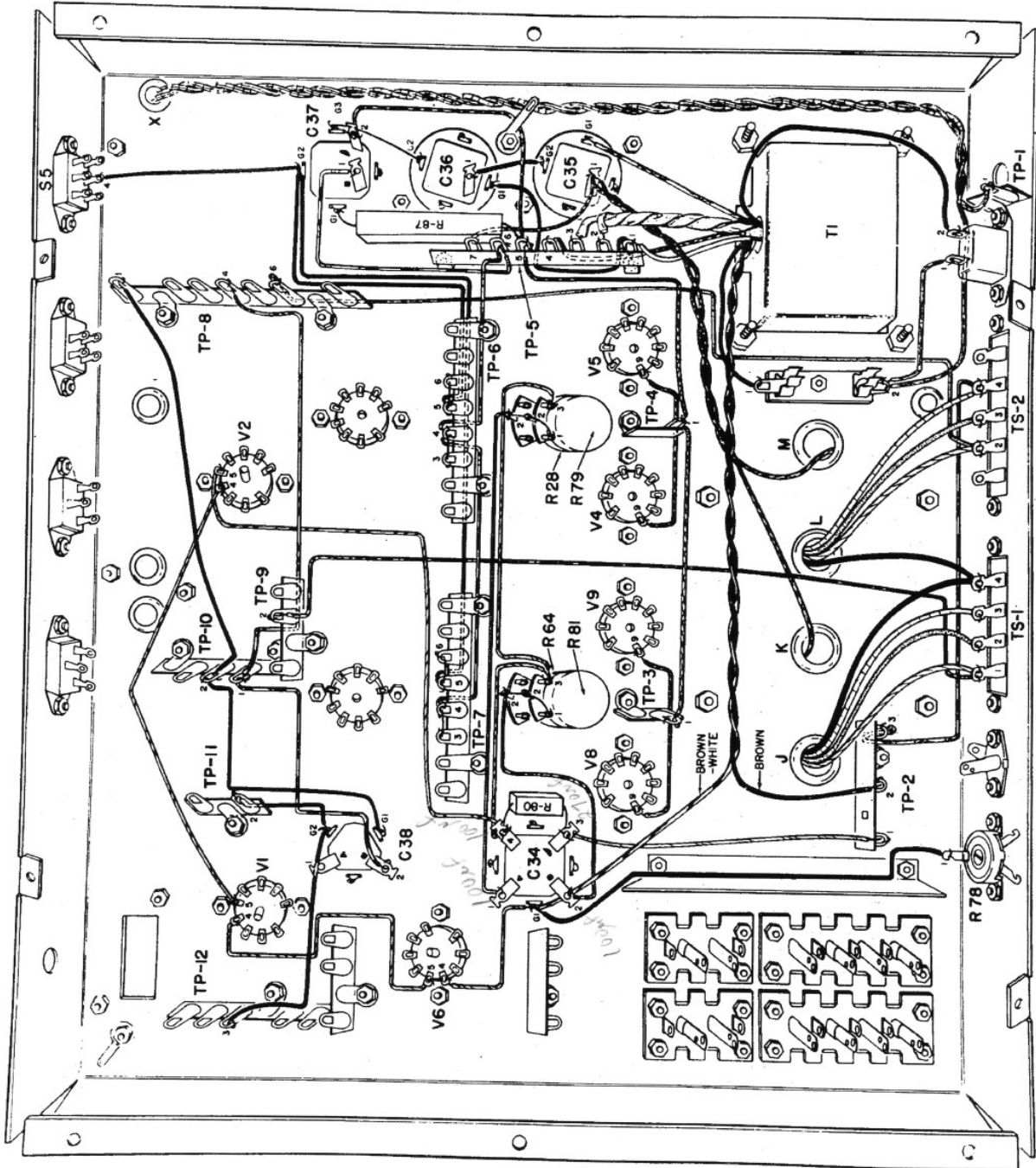

PICTORIAL 4 UNDERCHASSIS WIRING

## WIRING

- 54.( ) Connect a 4-1/4" length of black lead from C38 lug G2 (NS) to TP-12 lug 3 (NS).
- 55.( ) Twist together two 25" lengths of blue lead. Cut a 18-1/2" length of this twisted pair. At one end, untwist 2-1/2" of the pair, and cut off 2" from one lead. Connect the shorter lead to TP-1 lug 1 (NS), and run the longer lead underneath the AC receptacle, connecting it to lug 2 of the fuseholder (NS).
- 56.( ) Route the lead as shown in Pictorial 4 and feed the free end through grommet hole X. Referring to Pictorial 6, connect one lead to S6 lug 1 (S-1), the other lead to S6 lug 2 (S-1).
- 57.( ) Connect a 3-1/4" length of blue/white lead from TP-12 lug 1 (NS) to C38 lug 1 (NS). Refer to Pictorial 5.
- 58.( ) Connect a 3-1/2" length of blue/white lead from TP-11 lug 1 (NS) to C38 lug 1 (NS).
- 59.( ) Connect a 6" length of blue/white lead from TP-12 lug 1 (NS) to TP-14 lug 3 (NS).
- 60.( ) Connect a 3" length of black lead from C38 lug G2 (S-3) to TP-13 lug 2 (NS).
- 61.( ) Connect a 6-3/4" length of black lead from R78 lug 1 (S-1) to C34 lug G1 (S-3). Refer to Pictorial 4.
- 62.( ) Connect a 8" length of green lead from C34 lug 1 (S-1) to R28 lug 2 (S-2).
- 63.( ) Connect a 3" length of blue lead from fuseholder lug 2 (S-2) to the AC receptacle lug 1 (S-1).  
Refer to Pictorials 5 and 6.
- 64.( ) Cut a 22-1/4" length of 4-conductor cable (grey insulation-covered). Remove 2" of outer insulation from one end, and cut the four leads to the following dimensions: White - 1-3/4"; Brown - 1-3/4"; Black - 2"; Red - 1-1/4". Remove 3-1/2" of outer insulation from the other end of the cable and cut these leads to the following dimensions: White - 1-3/4"; Brown - 3-1/8"; Black - 3-1/2"; Red - 1-3/4".  
Run the cable along one side of the chassis from S5 to TS-2. The end with the 3-1/2" black lead should be at TS-2.
- 65.( ) At the end near S5, connect the red lead to S5 lug 6 (NS); the brown lead to S5 lug 4 (S-2); the white lead to S5 lug 2 (NS); the black lead to S5 lug 3 (S-1). Dress the leads as close to the switch body as possible, leaving all lugs clear for further wiring.
- 66.( ) At the end near TS-2, connect the white lead to TS-2 lug 5 (S-1); the red lead to TS-2 lug 1 (S-1); the brown lead to TS-1 lug 4 (S-3); the black lead through grommet hole N to the top side of the chassis. Leave the free end of black lead disconnected. Using a large screwdriver, press the cable clip down firmly against the side of the chassis to hold the cable securely.
- 67.( ) PREPARING TWISTED PAIRS OF LEADS: If either a hand or electric drill is available, these leads may be neatly twisted by inserting the ends into the chuck of the drill and operating it for a short period (two or three twists per inch of lead is desirable).  
Prepare a 4-1/2" length of black and green/white twisted pair of leads. At one end, connect the black lead to V4 pin 4 (NS), and the green/white lead to V4 pin 5 (NS). At the other end, connect the black lead to V5 pin 4 (S-1), and the green/white to V5 pin 5 (S-1).
- 68.( ) Prepare a 4-1/2" length of black and blue/white twisted pair of leads. At one end of the twisted pair, connect the black lead to V8 pin 4 (NS) and the blue/white lead to V8 pin 5 (NS). At the other end of the twisted pair, connect the black lead to V9 pin 4 (NS) and the blue/white lead to V9 pin 5 (NS).
- 69.( ) Prepare a 9" length of black and blue/white twisted pair of leads. At one end, connect the black lead to R78 lug 3 (S-1), the blue/white lead to R78 lug 2 (S-1). At the other end, connect the black lead to V8 pin 4 (S-2), the blue/white lead to V8 pin 5 (S-2).
- 70.( ) Prepare a 7-1/2" length of black and blue/white twisted pair of leads. At one end, connect the black lead to V9 pin 4 (NS) and the blue/white lead to V9 pin 5 (NS). At the other end, connect the black lead to TP-5 lug 3 (NS) and the blue/white lead to TP-5 lug 2 (NS).

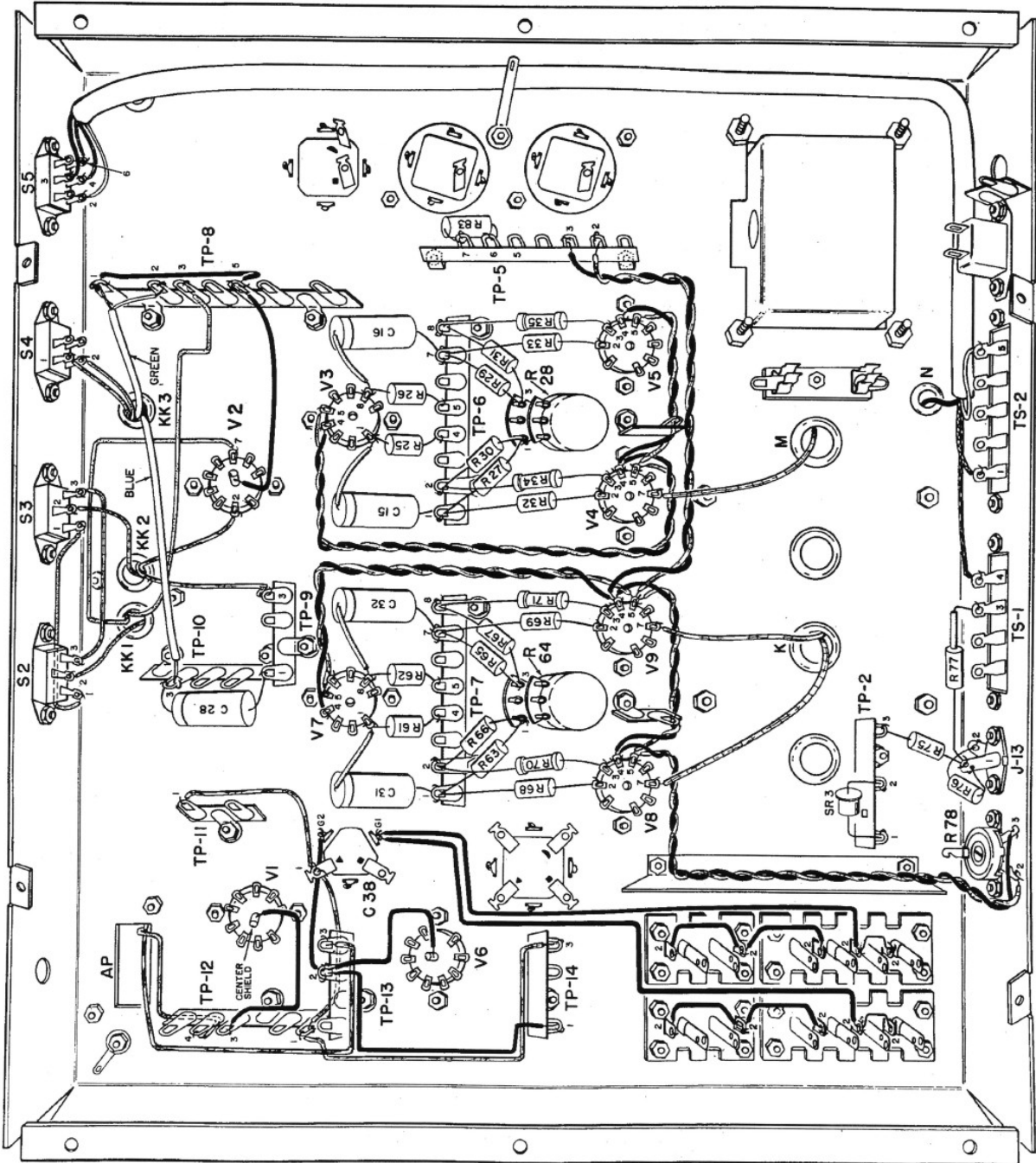

PICTORIAL 5 UNDERCHASSIS WIRING

## WIRING

- 71.( ) Connect the blue transformer lead from grommet hole K to V8 pin 7 (NS).
- 72.( ) Connect the blue/white transformer lead from grommet hole K to V9 pin 7 (S-1).
- 73.( ) Prepare a 7" length of black and blue/white twisted pair of leads. At one end, connect the black lead to V9 pin 4 (S-3) and the blue/white to V9 pin 5 (S-3). At the other end, connect the black lead to V7 pin 4 (S-1) and the blue/white lead to V7 pin 5 (S-1).
- 74.( ) Prepare a 9-1/4" length of black and green/white twisted pair of leads. At one end, connect the black lead to V4 pin 4 (NS) and the green/white lead to V4 pin 5 (NS). At the other end, connect the black lead to V3 pin 4 (S-1), and the green/white lead to V3 pin 5 (S-1).
- 75.( ) Connect the blue transformer lead from grommet hole M to V4 pin 7 (NS).
- 76.( ) Cut each lead of a 2, 200 ohm 1 watt resistor R83 (red-red-red-silver) to 5/8". Connect from TP-5 lug 6 (S-3) to TP-5 lug 7 (NS).
- 77.( ) Connect one end of a 6" length of green/white lead to V2 pin 7 (S-1). Dress lead exactly as shown in Pictorial 5 routing the lead through grommet hole KK1 to the topside of the chassis. Refer to Pictorial 6 and connect to TP-15 lug 2 (NS) on the topside of the chassis.
- 78.( ) Connect one end of a 3-1/4" length of blue/white lead to TP-15 lug 1 (NS). Route lead through grommet hole KK2 to the underside of the chassis and connect to V2 pin 2 (S-1).
- 79.( ) Connect one end of a 2-1/4" length of green/white lead to S4 lug 2 (NS). Route lead through grommet hole KK3 to the topside of the chassis. Connect to R18 lug 4 (S-1).
- 80.( ) Connect one end of a 2-1/2" length of blue/white lead to R54 lug 4 (S-1). Route lead through grommet hole KK3 to the underside of the chassis and connect to S4 lug 1 (NS).
- 81.( ) Connect a 3-3/4" length of green lead from S2 lug 1 (NS) to S3 lug 1 (S-1). Dress lead exactly as shown in Pictorial 5, keeping the lead away from the chassis and the green/white lead beneath it. In this manner, crosstalk between channels will be kept to a minimum.
- 82.( ) Connect a 3-3/4" length of blue lead from S3 lug 3 (S-1) to S2 lug 3 (NS). Dress lead as shown in Pictorial 5, keeping the lead at least 1/4" away from the green lead connected in the previous step.
- 83.( ) Connect one end of a 4-1/4" length of green lead to S2 lug 2 (NS). Route lead through grommet hole KK1 to the topside of the chassis; then refer to Pictorial 6 for connection to R13 lug 3 (NS).
- 84.( ) Connect one end of a 4-1/4" length of blue lead to R49 lug 3 (NS). Route lead through grommet hole KK2 to the underside of the chassis, keeping the lead away from the blue lead connected to S3. Referring to Pictorial 5, connect the free end to S3 lug 2 (NS).
- 85.( ) Connect one end of a 9-1/2" length of green/white lead to TP-8 lug 3 (NS). Route lead through grommet hole KK1 to the topside of the chassis for connection to R13 lug 1 (NS).
- 86.( ) Connect one end of a 6" length of blue/white lead to R49 lug 1 (NS). Route lead through grommet hole KK2 to the underside of the chassis for connection to TP-9 lug 3 (NS).
- 87.( ) Select a 6" length of single conductor green shielded cable and remove 1-1/4" of outside insulation from one end. Twist the strands of the shield together and tin. Slip a 5/8" length of sleeving over this shield wire. Cut the center lead to 5/8" and strip 1/4" of insulation from it.  
Remove 1" of outside insulation from the other end of the cable; twist the strands of the shield together and tin. Remove 1/4" of insulation from the center lead. See Figure 3 for preparation of shielded cables.

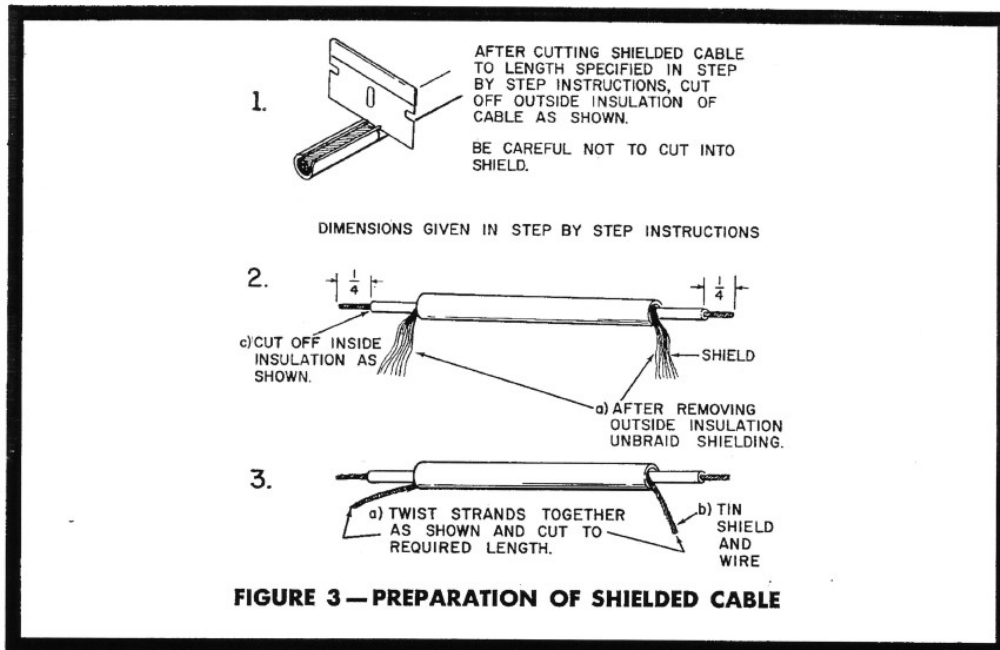

**FIGURE 3 — PREPARATION OF SHIELDED CABLE**

- 88.( ) Bend the lugs of R18 upwards slightly. Connect the end of the green shielded cable with sleeving over the shield as follows: the center lead to R18 lug 2 (S-1), the shield lead to R18 lug 1 (NS). Make sure the shield lead does not short to the metal case of the control. Feed the free end of the cable through the grommet hole KK3 as shown in Pictorials 5 and 6. Connect this end to TP-8, the center lead to lug 2 (NS), and the shield lead to lug 1 (NS).
- 89.( ) Select a 7-1/2" length of single conductor blue shielded cable. Remove 1-1/4" of outside insulation from one end, twist together the strands of the shield and tin. Slip a 5/8" length of sleeving over this shield wire. Cut the center lead to 5/8" and strip 1/4" of insulation from it. Remove 5/8" of outside insulation from the other end of the cable and cut off the shielding. Strip 1/4" of insulation from the center lead.
- 90.( ) Connect the end of the blue cable without shielding to TP-10 lug 3 (NS). Route the cable as shown in Pictorial 5 through grommet hole KK3 to the topside of the chassis. Referring to Pictorial 6, bend the lugs of R54 upwards slightly. Connect the center lead of the free end of the cable to R54 lug 2 (S-1), the shield lead to R54 lug 1 (NS). Make sure the shield lead does not short to the metal case of the control.
- 91.( ) Connect a 2-3/4" length of black lead from R18 lug 1 (NS) to R73 lug 1 (S-1).
- 92.( ) Connect a 2-3/4" length of black lead from R54 lug 1 (NS) to R74 lug 1 (S-1).
- 93.( ) Connect a 2-3/4" length of green lead from R18 lug 3 (NS) to R73 lug 3 (S-1).
- 94.( ) Connect one end of a 3" length of bare wire to R18 lug 1 (S-3). Cut the wire to 5/8" and connect the free end to R54 lug 1 (S-3).
- 95.( ) Connect a 2-3/4" length of blue lead from R54 lug 3 (NS) to R74 lug 3 (S-1).

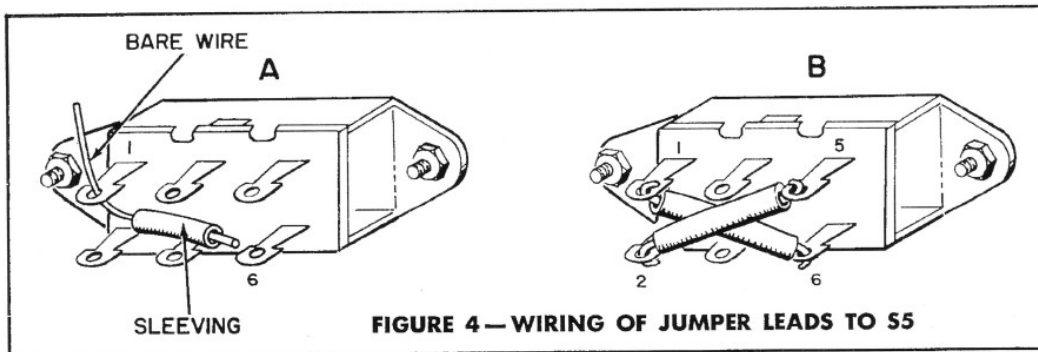

**FIGURE 4—WIRING OF JUMPER LEADS TO S5**

WIRING

- 96.( ) Connect one end of a 3" length of bare wire to R73 lug 2 (S-1). Cut the wire to 5/8" and connect the free end to R74 lug 2 (S-1).
- 97.( ) Connect one end of a 4-1/2" length of green/white lead to TP-12 lug 4 (NS) on the underside of the chassis. Route the lead as shown in Pictorial 5, feeding it through hole AP. Connect the free end to TP-16 lug 2 (NS). Refer to Pictorial 6 for connection to TP-16.
- 98.( ) Connect a 7-5/8" length of blue/white lead from TP-13 lug 3 (NS) to TP-16 lug 1 (NS). Route lead through hole AP to the topside of chassis. Dress as shown in Pictorials 5 and 6.

Refer to Figure 4

- 99.( ) Cut a 4" length of bare wire. Slip the wire through lug 1 of S-5 in the direction of lug 6. Slip a 5/8" length of sleeving over the wire before connecting to lug 6 (S-2). Cut off excess wire at the other end and crimp around lug 1 (S-1).
- 100.( ) Similarly, connect a bare wire (with sleeving) from S5 lug 5 (S-1) to S5 lug 2 (S-2).

Refer to Pictorial 3 for Phono Jack Numbering and Pictorial 5 for Actual Wiring.

- 101.( ) Connect a 2-1/4" length of black lead from J3 lug 2 (NS) to J2 lug 2 (NS).
- 102.( ) Connect a 2-1/4" length of black lead from J6 lug 2 (NS) to J5 lug 2 (NS).
- 103.( ) Connect a 2-3/4" length of black lead from J2 lug 2 (S-2) to J1 lug 2 (S-1).
- 104.( ) Connect a 2-3/4" length of black lead from J5 lug 2 (S-2) to J4 lug 2 (S-1).
- 105.( ) Connect a 1" length of bare wire from J8 lug 2 (NS) to J9 lug 2 (NS). Position this wire as shown.
- 106.( ) Connect a 1" length of bare wire from J11 lug 2 (NS) to J12 lug 2 (NS). Position this wire as shown.

Refer to Pictorial 5

- 107.( ) Connect an 8-1/2" length of black lead from J8 lug 2 (S-2) to C38 lug G1 (NS).
- 108.( ) Connect a 9-1/2" length of black lead from J11 lug 2 (S-2) to C38 lug G1 (S-3).
- 109.( ) Connect a 5" length of black lead from TP-14 lug 1 (NS) to TP-13 lug 2 (NS).
- 110.( ) Connect a 3-1/4" length of black lead from TP-8 lug 5 (NS) to TP-8 lug 1 (NS).
- 111.( ) Prepare a 6" length of black and green/white twisted pair of leads. At one end, connect the black lead to V4 pin 4(S-3), and the green/white to V4 pin 5(S-3). At the other end, connect the black lead to TP-5 lug 3 (S-3), and the green/white lead to TP-5 lug 2 (S-3). Refer to Pictorial 7.



### WIRING

- 112.( ) Connect the blue/white transformer lead from grommet hole M to V5 pin 7 (S-1).
- 113.( ) Connect a 4" length of black wire from the center ground lug of V2 to TP-8 lug 5 (NS). Solder the center ground lug of V2. Dress lead as shown in Pictorial 5.
- 114.( ) Connect a 3-3/4" length of black lead from the center ground lug of V1 to TP-12 lug 3 (NS). Solder the center ground lug of V1. Dress lead as shown.
- 115.( ) Connect a 3" length of black lead from the center ground lug of V6 to TP-13 lug 2 (NS). Solder the center ground lug of V6.
- 116.( ) Cut both leads of a 270K ohm 1/2 watt resistor R63 (red-violet-yellow-silver) to 5/8". Connect from R64 lug 1 (NS) to TP-7 lug 1 (NS).
- 117.( ) Cut both leads of a 270K ohm 1/2 watt resistor R27 (red-violet-yellow-silver) to 5/8". Connect from R28 lug 1 (NS) to TP-6 lug 1 (NS).
- 118.( ) Cut both leads of a 270K ohm 1/2 watt resistor R65 (red-violet-yellow-silver) to 1/2". Connect from R64 lug 3 (NS) to TP-7 lug 7 (NS).
- 119.( ) Cut both leads of a 270K ohm 1/2 watt resistor R29 (red-violet-yellow-silver) to 1/2". Connect from R28 lug 3 (NS) to TP-6 lug 7 (NS).
- 120.( ) Cut both leads of an 18K ohm 1/2 watt resistor R66 (brown-grey-orange-silver) to 1/2". Connect from R64 lug 1 (S-2) to TP-7 lug 2 (NS).
- 121.( ) Cut both leads of an 18K ohm 1/2 watt resistor R30 (brown-grey-orange-silver) to 1/2". Connect from R28 lug 1 (S-2) to TP-6 lug 2 (NS).
- 122.( ) Cut both leads of an 18K ohm 1/2 watt resistor R67 (brown-grey-orange-silver) to 5/8". Connect from R64 lug 3 (S-2) to TP-7 lug 8 (NS).
- 123.( ) Cut both leads of an 18K ohm 1/2 watt resistor R31 (brown-grey-orange-silver) to 5/8". Connect from R28 lug 3 (S-2) to TP-6 lug 8 (NS).
- 124.( ) Cut both leads of a 1K ohm 1/2 watt resistor R68 (brown-black-red-silver) to 1-1/16". Connect from V8 pin 2 (S-1) to TP-7 lug 1 (NS).
- 125.( ) Cut both leads of a 1K ohm 1/2 watt resistor R32 (brown-black-red-silver) to 1". Connect from V4 pin 2 (S-1) to TP-6 lug 1 (NS).
- 126.( ) Cut both leads of a 1K ohm 1/2 watt resistor R69 (brown-black-red-silver) to 1". Connect from V9 pin 2 (NS) to TP-7 lug 7 (NS).
- 127.( ) Cut both leads of a 1K ohm 1/2 watt resistor R33 (brown-black-red-silver) to 1". Connect from V5 pin 2 (NS) to TP-6 lug 7 (NS).
- 128.( ) Select a 10 ohm 1/2 watt resistor R70 (value marked on resistor). Cut one lead to 1", the other to 3/4". Connect the longer lead to TP-7 lug 2 (S-2), the shorter lead to V8 pin 3 (S-1).
- 129.( ) Select a 10 ohm 1/2 watt resistor R34 and cut one lead to 1", the other to 3/4". Connect the longer lead to TP-6 lug 2 (S-2), the shorter lead to V4 pin 3 (S-1).
- 130.( ) Select a 10 ohm 1/2 watt resistor R71 and cut one lead to 1", the other to 3/4". Connect the 3/4" lead to V9 pin 3 (S-1) and the other lead to TP-7 lug 8 (S-2).
- 131.( ) Select a 10 ohm 1/2 watt resistor R35 and cut one lead to 1", the other to 3/4". Connect the 3/4" lead to V5 pin 3 (S-1) and the other lead to TP-6 lug 8 (S-2).

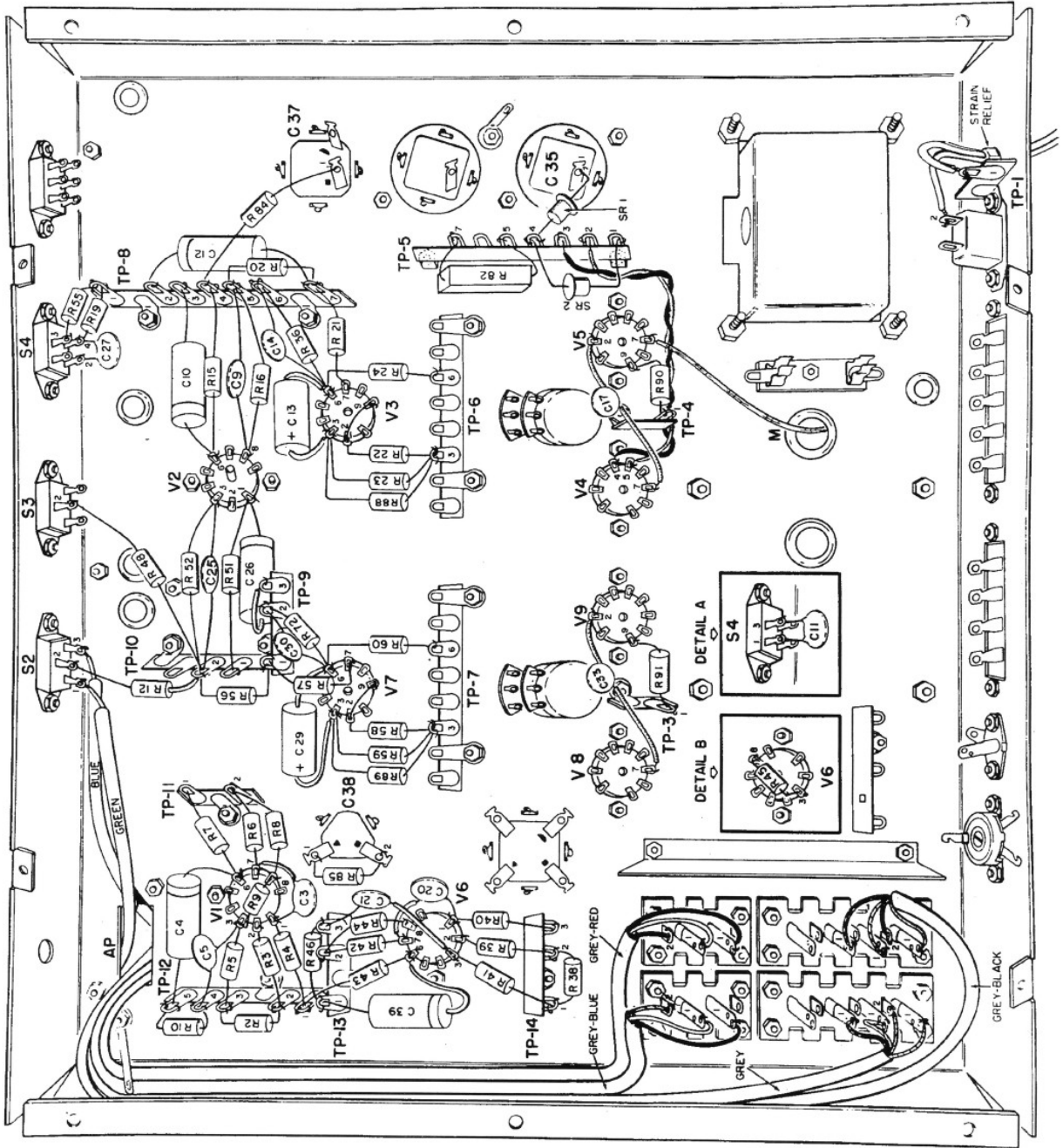

**PICTORIAL 7  
UNDERCHASSIS WIRING**

## WIRING

- 132.( ) Cut both leads of a 2, 200 ohm 1/2 watt resistor R76 (red-red-red-silver) to 5/8". Connect from J13 lug 2 (S-1) to J13 lug 1 (NS).
- 133.( ) Cut one lead of a 27K ohm 1/2 watt resistor R77 (red-violet-orange-silver) to 1", the other lead to 1-1/4". Slip a 5/8" length of sleeving over the shorter lead and connect this end to TS-1 lug 3 (S-2). Connect the other end to J13 lug 1 (NS).
- 134.( ) Cut both leads of a 27K ohm 1/2 watt resistor R75 (red-violet-orange-silver) to 1/2". Connect from J13 lug 1 (S-3) to TP-2 lug 3 (S-2).
- 135.( ) Cut both leads of a silicon diode SR-3, part #17-10 (marked on component), to 3/4". Connect from TP-2 lug 1 (S-2) to TP-2 lug 2 (S-2). Orient exactly as shown in Pictorial 5.
- 136.( ) Select a 0.1 $\mu$ f molded tubular capacitor (C16). Cut the lead from the outside foil end (indicated by a line) to 1-1/4", the other lead to 1". Slip a 1" length of sleeving on the longer lead and connect to V3 pin 8 (NS). Connect the other end to TP-6 lug 7 (S-3). Dress the component as shown.
- 137.( ) Select a 0.1 $\mu$ f molded tubular capacitor (C32). Cut the lead from the outside foil end to 1-1/4", the other lead to 1". Slip a 1" length of sleeving on the longer lead and connect to V7 pin 8 (NS). Connect the other end to TP-7 lug 7 (S-3).
- 138.( ) Select a 0.1 $\mu$ f molded tubular capacitor (C31). Cut the lead from the outside foil end to 1-1/4", the other lead to 1". Slip a 1" length of sleeving on the longer lead and connect to V7 pin 1 (NS). Connect the other lead to TP-7 lug 1 (S-3).
- 139.( ) Select a 0.1 $\mu$ f molded tubular capacitor (C15). Cut the lead from the outside foil end to 1-1/4", the other lead to 1". Slip a 1" length of sleeving on the longer lead and connect to V3 pin 1 (NS). Connect the other end to TP-6 lug 1 (S-3).
- 140.( ) Cut both leads of a 15K ohm 1 watt 5% resistor R26 (brown-green-orange-gold) to 9/16" and connect from V3 pin 8 (S-2) to TP-6 lug 5 (S-3).
- 141.( ) Cut both leads of a 15K ohm 1 watt 5% resistor R62 (brown-green-orange-gold) to 9/16" and connect from V7 pin 8 (S-2) to TP-7 lug 5 (S-3).
- 142.( ) Cut both leads of a 15K ohm 1 watt 5% resistor R25 (brown-green-orange-gold) to 9/16" and connect from V3 pin 1 (S-2) to TP-6 lug 4 (S-4).
- 143.( ) Cut both leads of a 15K ohm 1 watt 5% resistor R61 (brown-green-orange-gold) to 9/16" and connect from V7 pin 1 (S-2) to TP-7 lug 4 (S-3).
- 144.( ) Cut both leads of a 0.1 $\mu$ f molded tubular capacitor C28 to 3/4" and connect from TP-10 lug 3 (S-2) to TP-9 lug 1 (NS). Connect the outside foil end to TP-10 as shown.

### Refer to Pictorial 7

- 145.( ) Cut one lead of a 91K ohm 1 watt resistor R58 (white-brown-orange-gold) to 1/2". Leave the other lead full length. Slip the long lead through V7 pin 2 (NS) and connect to V7 pin 9 (S-1). Bend the lead as shown and connect the other end of the resistor to TP-7 lug 3 (NS). Solder V7 pin 2 (S-1).
- 146.( ) Cut one lead of a 91K ohm 1 watt resistor R22 (white-brown-orange-gold) to 1/2". Leave the other lead full length. Slip the long lead through V3 pin 2 (NS) and connect to V3 pin 9 (S-1). Bend the lead as shown and connect the other end of the resistor to TP-6 lug 3 (NS). Solder V3 pin 2 (S-1).
- 147.( ) Cut both leads of a 75  $\mu$ f 5% ceramic disc capacitor (C14) to 3/4". Connect from V3 pin 6 (NS) to TP-8 lug 6 (NS).
- 148.( ) Cut both leads of a 4.7  $\mu$ f ceramic disc capacitor (C33) to 1-1/4". Slip a 1" length of sleeving over each lead and connect from V9 pin 2 (S-2) to V8 pin 7 (S-2).
- 149.( ) Cut both leads of a 4.7  $\mu$ f ceramic disc capacitor (C17) to 1-1/4". Slip a 1" length of sleeving over each lead and connect from V4 pin 7 (S-2) to V5 pin 2 (S-2).
- 149a ( ) Cut one lead of a 470 ohm 2 watt resistor R90 (yellow-violet-brown-silver) to 1/2". Cut the other lead to 5/8" and connect to V5 pin 9 (S-2). Connect the 1/2" lead to TP-4 lug 1 (S-3).
- 149b ( ) Cut one lead of a 470 ohm 2 watt resistor R91 (yellow-violet-brown-silver) to 1/2". Cut the other lead to 5/8" and connect to V9 pin 9 (S-2). Connect the 1/2" lead to TP-3 lug 1 (S-2).

## WIRING

150. ( ) Cut both leads of a 75  $\mu$ f 5% ceramic disc capacitor (C30) to 1/2" and connect from V7 pin 6 (NS) to TP-9 lug 2 (NS).
151. ( ) Cut one lead of a 560K ohm 1/2 watt resistor R23 (green-blue-yellow-silver) to 1-3/8", the other to 3/4". Connect the longer lead to V3 pin 3 (NS), and the other lead to TP-6 lug 3 (NS).
- 151a ( ) Cut one lead of a 680K ohm 1/2 watt resistor R88 (blue-gray-yellow-silver) to 7/8". Cut the other lead to 1-1/2" and connect to V3 pin 3 (NS). Connect the 7/8" lead to TP-6 lug 3 (S-4).
152. ( ) Cut one lead of a 560K ohm 1/2 watt resistor R59 (green-blue-yellow-silver) to 1-3/8", the other to 3/4". Connect the longer lead to V7 pin 3 (NS) and the other lead to TP-7 lug 3 (NS).
- 152a ( ) Cut one lead of a 680K ohm 1/2 watt resistor R89 (blue-gray-yellow-silver) to 7/8". Cut the other lead to 1-1/2" and connect to V7 pin 3 (NS). Connect the 7/8" lead to TP-7 lug 3 (S-4).
153. ( ) Cut one lead of a 330 ohm 1/2 watt resistor R24 (orange-orange-brown-silver) to 1-1/4", and the other to 7/8". Connect the longer lead to V3 pin 6 (NS) and the other lead to TP-6 lug 6 (S-2).
154. ( ) Cut one lead of a 330 ohm 1/2 watt resistor R60 (orange-orange-brown-silver) to 1-1/4", the other to 7/8". Connect the longer lead to V7 pin 6 (NS) and the other lead to TP-7 lug 6 (S-2).
155. ( ) Cut both leads of a 27K ohm 1/2 watt resistor R72 (red-violet-orange-silver) to 1/2" and connect from V7 pin 6 (NS) to TP-9 lug 2 (S-3).
156. ( ) Cut both leads of a 27K ohm 1/2 watt resistor R36 (red-violet-orange-silver) to 3/4" and connect from V3 pin 6 (NS) to TP-8 lug 6 (S-3).
157. ( ) Cut both leads of a 0.1  $\mu$ f molded tubular capacitor C12 to 7/8" and connect from TP-8 lug 2 (S-2) to TP-8 lug 7 (NS). Connect the outside foil end to lug 2.
158. ( ) Cut each lead of a 4,700 ohm 1/2 watt resistor R84 (yellow-violet-red-silver) to 1-1/4". Connect from C37 lug 1 (S-2) to TP-8 lug 4 (NS).
159. ( ) Cut both leads of a 10K ohm 1/2 watt resistor R57 (brown-black-orange-silver) to 1/2" and connect from TP-9 lug 1 (NS) to V7 pin 7 (S-1). Make sure the resistor is raised--away from the components beneath it.
160. ( ) Cut both leads of a 10K ohm 1/2 watt resistor R21 (brown-black-orange-silver) to 7/8" and connect from TP-8 lug 7 (NS) to V3 pin 7 (S-1). Raise the resistor--away from the components beneath it.
161. ( ) Cut both leads of a 1 Meg ohm 1/2 watt resistor R56 (brown-black-green-silver) to 1". Connect from TP-10 lug 2 (NS) to TP-9 lug 1 (S-3).
162. ( ) Cut both leads of a 1 Meg ohm 1/2 watt resistor R20 (brown-black-green-silver) to 3/4". Connect from TP-8 lug 5 (NS) to TP-8 lug 7 (S-3).
163. ( ) Cut both leads of a 450 ohm 7 watt resistor R82 (value marked on resistor) to 1-1/4". Connect from TP-5 lug 7 (S-3) to TP-5 lug 5 (S-4).
164. ( ) Select the silicon diode SR-1, part #17-9 (marked on component). Cut the lead at the wide end of the diode to 7/8". Cut the other lead to 5/8". Connect the 7/8" lead to C35 lug 1 (S-4), the 5/8" lead to TP-5 lug 4 (NS).
165. ( ) Cut both leads of a silicon diode SR2 (part #17-9) to 1-1/8" and, orienting as shown in Pictorial 7, connect from TP-5 lug 1 (S-3) to TP-5 lug 4 (S-3). Make sure the diode is no higher than the lugs of the terminal post; this prevents accidental shorting when the bottom plate is attached to the chassis later on. Dress as shown in Pictorial 7, keeping the diode away from R82.
166. ( ) Cut both leads of a 10  $\mu$ f 200 volt electrolytic capacitor C13 (value marked on capacitor) to 7/8". Slip a 5/8" length of sleeving over each end. Connect the positive lead (+) to V3 pin 3 (S-3) and the other lead to V3 pin 6 (S-4).
167. ( ) Cut the positive lead of a 10  $\mu$ f 200 volt electrolytic capacitor C29 to 1-7/8", and the other lead to 1". Slip a 1-1/2" length of sleeving on the positive lead and a 3/4" length of sleeving on the other lead. Connect the positive lead to V7 pin 3 (S-3) and the other lead to V7 pin 6 (S-4). Dress the component as shown in Pictorial 7.

## WIRING

168. ( ) Cut both leads of a 27K ohm 1/2 watt resistor R19 (red-violet-orange-silver) to 1/2". Connect from TP-8 lug 1 (NS) to S4 lug 4 (NS).
169. ( ) Cut both leads of a 27K ohm 1/2 watt resistor R55 (red-violet-orange-silver) to 1/2". Connect from TP-8 lug 1 (S-5) to S4 lug 3 (NS).
170. ( ) Cut both leads of a 0.02 $\mu$ f ceramic disc capacitor C27 (value marked on capacitor) to 3/8". Connect from S4 lug 4 (S-2) to S4 lug 2 (S-2).
171. ( ) Cut both leads of a 0.02 $\mu$ f ceramic disc capacitor C11 to 3/8". Connect from S4 lug 3 (S-2) to S4 lug 1 (S-2). See Detail A of Pictorial 7.
172. ( ) Cut the lead from the outside foil end of a 0.1 $\mu$ f molded tubular capacitor C26 to 1/2". Cut the other lead to 1-1/8". Slip a 3/4" length of sleeving over the longer lead and connect to TP-9 lug 3 (S-2). Connect the shorter lead to V2 pin 1 (NS).
173. ( ) Cut both leads of a 0.1 $\mu$ f molded tubular capacitor C10 to 3/4". Connect the outside foil end to V2 pin 6 (NS), and the other end to TP-8 lug 3 (S-2).
174. ( ) Cut both leads of a 100K ohm 1/2 watt resistor R15 (brown-black-yellow-silver) to 1-1/4". Connect from V2 pin 6 (S-2) to TP-8 lug 4 (S-3).
175. ( ) Cut both leads of a 100K ohm 1/2 watt resistor R51 (brown-black-yellow-silver) to 1-1/8". Connect from V2 pin 1 (S-2) to TP-10 lug 1 (S-3).
176. ( ) Cut both leads of an 820 ohm 1/2 watt resistor R16 (grey-red-brown-silver) to 1-1/4". Connect from V2 pin 8 (NS) to TP-8 lug 5 (NS).
- 176a ( ) Cut both leads of a 0.02 $\mu$ f ceramic disc capacitor C9 to 1-1/8". Connect from V2 pin 8 (S-2) to TP-8 lug 5 (S-5). Note: Use capacitor part #12-127
177. ( ) Cut both leads of an 820 ohm 1/2 watt resistor R52 (grey-red-brown-silver) to 1-1/4". Connect from V2 pin 3 (NS) to TP-10 lug 2 (NS).
- 177a ( ) Cut both leads of a 0.02 $\mu$ f ceramic disc capacitor C25 to 1". Connect from V2 pin 3 (S-2) to TP-10 lug 2 (NS). Note: Use capacitor part #12-127
178. ( ) Cut both leads of a 2.2 Meg ohm 1/2 watt resistor R48 (red-red-green-silver) to 1-1/8". Connect from S3 lug 2 (S-2) to TP-10 lug 2 (NS).
179. ( ) Cut a 6-1/4" length of green single conductor shielded cable. At one end, remove 1" of outside insulation. Twist together the strands of shielding and tin. Remove 1/4" of insulation from the center lead. At the other end, remove 7/8" of outside insulation and cut off the shielding. Remove 1/4" of insulation from the center lead.
180. ( ) At the end without shielding, connect the center lead of the green cable to S2 lug 1 (S-2). Feed the free end of the cable through hole AP to the topside of the chassis. Now connect the center lead to TP-17 lug 1 (NS) and the shield lead to TP-17 lug 2 (NS). Refer to Pictorial 6 for the front panel wiring.
181. ( ) Cut a 6-3/4" length of blue single conductor shielded cable. At one end, remove 3/4" of outside insulation. Twist together the shield strands and tin. Remove 1/4" of insulation from the center lead. At the other end, remove 7/8" of outside insulation and cut off the shielding. Remove 1/4" of insulation from the center lead.
182. ( ) At the end without shielding, connect the center lead of the blue cable to S2 lug 3 (S-2). Feed the free end of the cable through hole AP to the topside of the chassis. Now connect the center lead to TP-17 lug 3 (NS), the shield lead to TP-17 lug 4 (NS). Refer to Pictorial 6 for the front panel wiring.
183. ( ) Cut both leads of a 2.2 Megohm 1/2 watt resistor R12 (red-red-green-silver) to 5/8". Slip a 3/8" length of sleeving over one lead and connect to TP-10 lug 2 (S-7). Solder this connection carefully, using sufficient solder to run through all connections. Connect the other end of the resistor to S2 lug 2 (S-2).
184. ( ) Cut the lead from the outside foil end of a 0.1 $\mu$ f molded tubular capacitor C4 to 1", and the other lead to 3/4". Connect the longer lead to V1 pin 6 (NS) and the other lead to TP-12 lug 5 (NS).

## WIRING

- 185.( ) Cut the lead from the outside foil end of a 0.1 $\mu$ f molded tubular capacitor C39 to 1-1/2" and the other lead to 3/4". Slip a 1-1/4" length of sleeving over the longer lead and connect to V6 pin 6 (NS). Connect the other lead to TP-13 lug 1 (NS).
- 186.( ) Cut both leads of a 100K ohm 1/2 watt resistor R7 (brown-black-yellow-silver) to 5/8". Connect from V1 pin 6 (S-2) to TP-11 lug 1 (NS).
- 187.( ) Cut both leads of a 1 Meg ohm 1/2 watt resistor R6 (brown-black-green-silver) to 1/2". Connect from V1 pin 7 (NS) to TP-11 lug 2 (NS).
- 188.( ) Cut one lead of a 0.02 $\mu$ f ceramic disc capacitor C3 to 3/8" and the other lead to 3/4". Slip a 1/2" length of sleeving over the longer end and connect to V1 pin 7 (S-2). Connect the other lead to V1 pin 1 (NS).
- 189.( ) Cut both leads of a 1,200 ohm 1/2 watt resistor R8 (brown-red-red-silver) to 5/8". Connect from V1 pin 8 (NS) to TP-11 lug 2 (S-3).
- 190.( ) Cut one lead of a 220K ohm 1/2 watt resistor R4 (red-red-yellow - gold) to 5/8" and the other lead to 3/4". Connect the longer lead to TP-12 lug 1 (NS) and the other lead to V1 pin 1 (S-2).
- 191.( ) Cut both leads of a 10K ohm 1/2 watt resistor R3 (brown-black-orange-silver) to 5/8". Connect from V1 pin 2 (S-1) to TP-12 lug 2 (NS).
- 192.( ) Cut both leads of a 2,700 ohm 1/2 watt resistor R5 (red-violet-red - gold) to 5/8". Connect from V1 pin 3 (NS) to TP-12 lug 3 (NS).
- 193.( ) Cut both leads of a 470K ohm 1/2 watt resistor R2 (yellow-violet-yellow-silver) to 5/8". Connect from TP-12 lug 2 (NS) to TP-12 lug 3 (NS).
- 194.( ) Cut both leads of a 100K ohm 1/2 watt resistor R9 (brown-black-yellow-silver) to 1/2". Connect from V1 pin 3 (NS) to V1 pin 8 (S-2).
- 195.( ) Cut one lead of a 680 $\mu$ f ceramic disc capacitor C5 to 1/2", and the other lead to 5/8". Connect the longer lead to TP-12 lug 4 (NS) and the other lead to V1 pin 3 (S-3).
- 196.( ) Cut both leads of a 330K ohm 1/2 watt resistor R10 (orange-orange-yellow-silver) to 1/2". Connect from TP-12 lug 4 (S-3) to TP-12 lug 5 (NS).
- 197.( ) Cut both leads of an 8,200 ohm 1/2 watt resistor R85 (grey-red-red-silver) to 5/8". Connect from C38 lug 1 (S-3) to C38 lug 2 (S-2).
- 198.( ) Cut one lead of a 100K ohm 1/2 watt resistor R43 (brown-black-yellow-silver) to 1/2" and the other lead to 7/8". Connect the longer lead to TP-12 lug 1 (S-4) and the other lead to V6 pin 6 (S-2).
- 199.( ) Cut both leads of a 1 Meg ohm 1/2 watt resistor R42 (brown-black-green-silver) to 1/2". Connect from V6 pin 7 (NS) to TP-13 lug 2 (NS).
- 200.( ) Cut both leads of a 2,700 ohm 1/2 watt resistor R41 (red-violet-red - gold) to 5/8". Connect from V6 pin 3 (NS) to TP-14 lug 1 (NS).
- 201.( ) Cut one lead of a 0.02 $\mu$ f ceramic disc capacitor C20 to 1/2" and the other lead to 7/8". Slip a 5/8" length of sleeving over the longer lead and connect to V6 pin 7 (S-2). Connect the shorter lead to V6 pin 1 (NS).
- 202.( ) Cut both leads of a 1,200 ohm 1/2 watt resistor R44 (brown-red-red-silver) to 5/8". Connect from TP-13 lug 2 (S-5) to V6 pin 8 (NS).
- 203.( ) Cut both leads of a 220K ohm 1/2 watt resistor R40 (red-red-yellow - gold) to 1/2". Connect from V6 pin 1 (S-2) to TP-14 lug 3 (S-2).

## WIRING

- 204.( ) Cut both leads of a 10K ohm 1/2 watt resistor R39 (brown-black-orange-silver) to 1/2". Connect from V6 pin 2 (S-1) to TP-14 lug 2 (NS).
- 205.( ) Cut both leads of a 470K ohm 1/2 watt resistor R38 (yellow-violet-yellow-silver) to 5/8". Connect from TP-14 lug 1 (NS) to TP-14 lug 2 (NS).
- 206.( ) Cut both leads of a 100K ohm 1/2 watt resistor R45 (brown-black-yellow-silver) to 1/2". Connect from V6 pin 3 (NS) to V6 pin 8 (S-2). See Detail B in the Pictorial.
- 207.( ) Cut both leads of a 680 $\mu$ mf ceramic disc capacitor C21 to 3/4". Slip a 5/8" length of sleeving over one lead and connect to V6 pin 3 (S-3). Connect the other lead to TP-13 lug 3 (NS).
- 208.( ) Cut both leads of a 330K ohm 1/2 watt resistor R46 (orange-orange-yellow-silver) to 1". Connect from TP-13 lug 1 (NS) to TP-13 lug 3 (S-3).

### Refer to Pictorial 8 for Wiring of Front Panel Controls

- 209.( ) Select the two PC boards, (part #16-2). Turn one of the PC boards over with the unnumbered side facing you and wire leads pointing upwards. Using a pencil, number the leads on the board from 1 to 7, starting at the left-hand side. The numbers should match those on the other side. Repeat this procedure with the other PC board.
- 210.( ) Cut the leads of one PC board to the following dimensions:-  
Lead No. 1 - 1/2":      Lead No. 2 - 1-7/8":      Lead No. 3 - 1-5/8":      Lead No. 4 - 1-3/8":  
Lead No. 5 - 2-3/8":      Lead No. 6 - 3/4":      Lead No. 7 - 2-1/4".
- 211.( ) Slip a 2-1/8" length of sleeving over lead No. 5 and, holding the PC board with the penciled numbers facing you and the leads pointing upwards, bend lead No. 5 back and then downwards. Place the PC board between R13 and R14, and connect this lead to TP-15 lug 2 (S-2). Refer to Pictorial 8.
- 212.( ) Connect lead No. 1 to R13 lug 3 (NS).
- 213.( ) Slip a 1/2" length of sleeving over lead No. 6 and connect to R14 lug 1 (S-1).
- 214.( ) Slip a 1-1/8" length of sleeving over lead No. 4 and connect to R13 lug 2 (S-1).
- 215.( ) Slip a 1-1/4" length of sleeving over lead No. 3 and connect to R14 lug 2 (S-1).
- 216.( ) Slip a 1-5/8" length of sleeving over lead No. 2 and connect to R14 lug 3 (NS).
- 217.( ) Slip a 2" length of sleeving over lead No. 7 and connect to R13 lug 1 (NS).
- 218.( ) Cut the leads of the other PC board to the following dimensions:-  
Lead No. 1 - 1/2":      Lead No. 2 - 1-7/8":      Lead No. 3 - 1-5/8":      Lead No. 4 - 1-3/8":  
Lead No. 5 - 1-7/8":      Lead No. 6 - 3/4":      Lead No. 7 - 2-1/4".
- 219.( ) Slip a 1-1/2" length of sleeving over lead No. 5, and holding the PC board with the penciled numbers facing you and the leads pointing upwards, bend lead No. 5 back and then downwards. Place the PC board between R49 and R50 and connect this lead to TP-15 lug 1 (S-2).
- 220.( ) Connect lead No. 1 to R49 lug 3 (NS).
- 221.( ) Slip a 1/2" length of sleeving over lead No. 6 and connect to R50 lug 1 (S-1).
- 222.( ) Slip a 1-1/8" length of sleeving over lead No. 4 and connect to R49 lug 2 (S-1).

**PICTORIAL 8  
FRONT PANEL WIRING**

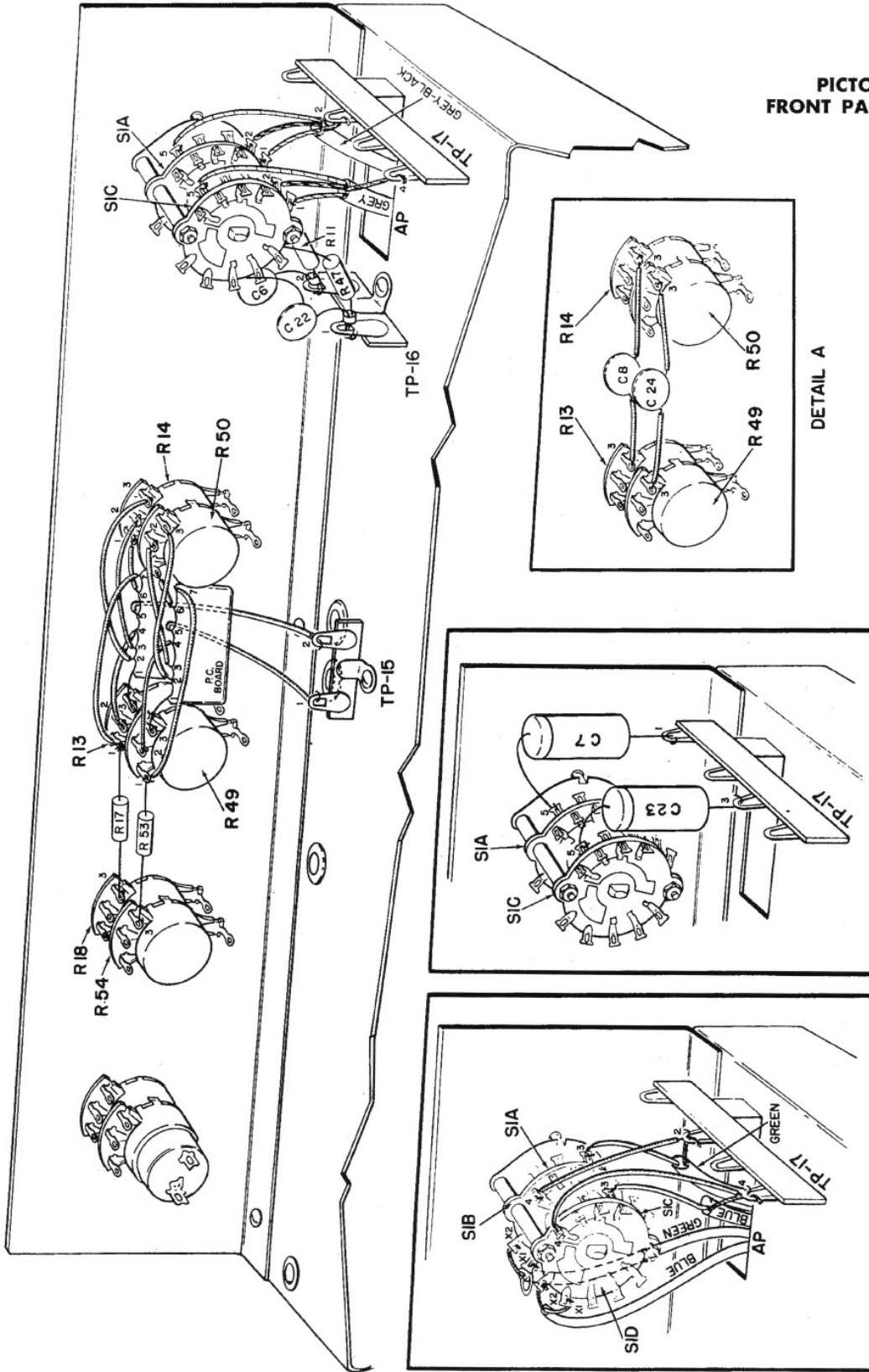

DETAIL A

DETAIL C

DETAIL B

## WIRING

- 223. ( ) Slip a 1-1/4" length of sleeving over lead No. 3 and connect to R50 lug 2 (S-1).
- 224. ( ) Slip a 1-5/8" length of sleeving over lead No. 2 and connect to R50 lug 3 (NS).
- 225. ( ) Slip a 2" length of sleeving over lead No. 7 and connect to R49 lug 1 (NS).
- 226. ( ) Cut both leads of a 22K ohm 1/2 watt resistor R17 (red-red-orange-silver) to 3/4". Connect from R18 lug 3 (S-2) to R13 lug 1 (S-3).
- 227. ( ) Cut both leads of a 22K ohm 1/2 watt resistor R53 (red-red-orange-silver) to 3/4". Connect from R54 lug 3 (S-2) to R49 lug 1 (S-3).
- 228. ( ) Cut both leads of a 6.8  $\mu$ f ceramic disc capacitor C8 to 1-1/4". Slip a 1" length of sleeving over each lead and connect from R14 lug 3 (S-2) to R13 lug 3 (S-3). See Detail A of Pictorial 8.
- 229. ( ) Cut both leads of a 6.8  $\mu$ f ceramic disc capacitor C24 to 1-1/4". Slip a 1" length of sleeving over each lead and connect from R50 lug 3 (S-2) to R49 lug 3 (S-3). See detail A of Pictorial 8.

## PREWIRING OF SELECTOR SWITCH S1

### Refer to Figure 5

- 230. ( ) Select the Selector Switch S1A, B, C, D, (part #14-24). To correctly identify the lugs, orient the switch as shown in Figure 5, with the locating lug towards you. Numbering is carried out in a counter-clockwise direction. The lugs marked with a red spot are always No. 1.
- 231. ( ) Cut both leads of a 100K ohm 1/2 watt resistor R47, (brown-black-yellow-silver) to 5/8". Connect one lead to S1C lug 8 (S-1). Leave the other lead disconnected.
- 232. ( ) Cut both leads of a 100K ohm 1/2 watt resistor R11 (brown-black-yellow-silver) to 5/8". Connect one lead to S1A lug 8 (S-1). Leave the other lead disconnected.
- 233. ( ) Cut a 3" length of bare wire and slip a 2-1/2" length of sleeving over it. Connect from S1C lug 7 (S-1) to S1C lug 4 (NS).
- 234. ( ) Cut a 3" length of bare wire and slip a 2-1/2" length of sleeving over it. Connect from S1A lug 7 (S-1) to S1A lug 4 (NS).
- 235. ( ) Cut a 15" length of 2-conductor grey/red shielded cable. Remove 1-1/2" of outside insulation from one end, twist the strands of shielding together and tin. Cut the shield lead to 3/4". Remove 1/4" of insulation from the white lead. Cut the black lead to 1", remove 1/4" of insulation.
- 236. ( ) Connect the white lead of the grey/red cable to S1B lug 7 (S-1), the black lead to S1B lug 5 (S-1) and the shield lead to S1B lug X2 (NS).
- 237. ( ) Cut both leads of a 220  $\mu$ f ceramic disc capacitor C6 to 5/8". Connect one end to S1A lug 6 (S-1). Leave the other end disconnected.
- 238. ( ) Cut both leads of a 0.04  $\mu$ f molded tubular capacitor C2 to 1/2". Connect from S1B lug 6 (S-1) to S1B lug X1 (NS).
- 239. ( ) Cut a 14" length of 2-conductor grey/blue shielded cable. Remove 1-1/2" of outside insulation from one end, twist the strands of shielding together and tin. Cut the shield lead to 3/4". Remove 1/4" of insulation from the white lead. Cut the black lead to 1", remove 1/4" of insulation.

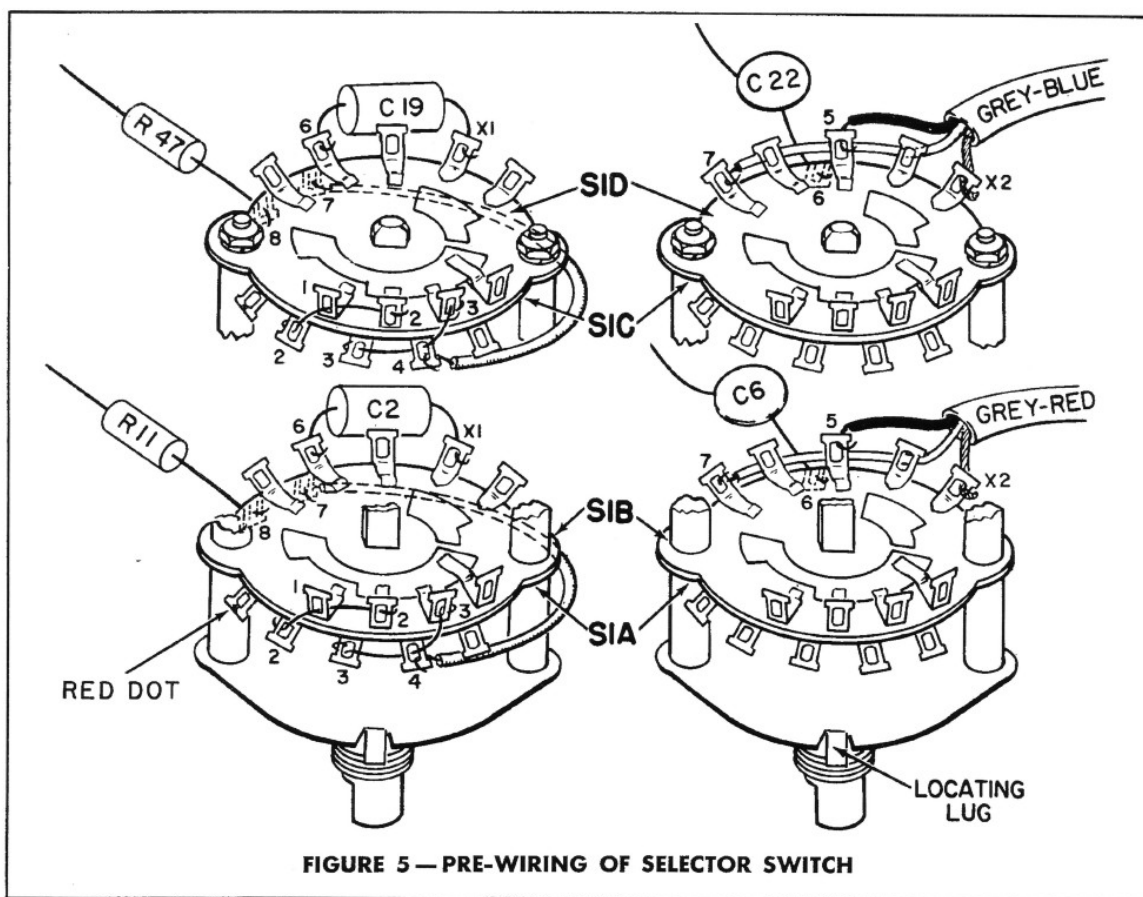

**FIGURE 5 — PRE-WIRING OF SELECTOR SWITCH**

- 240.( ) Connect the white lead of the grey/blue cable to S1D lug 7 (S-1), the black lead to S1D lug 5 (S-1) and the shield lead to S1D lug X2 (NS).
- 241.( ) Cut both leads of a 220 $\mu$ f ceramic disc capacitor C22 to 5/8". Connect one end to S1C lug 6 (S-1). Leave the other end disconnected.
- 242.( ) Cut both leads of a 0.04 $\mu$ f molded tubular capacitor C19 to 1/2". Connect from S1D lug 6 (S-1) to S1D lug X1 (NS).
- 243.( ) Slip a 4" length of bare wire through S1B lug 1 to S1A lug 2 (NS). Cut the wire from S1B lug 1 to 1/2" and connect the free end to S1B lug 2. Solder S1B lug 1 and lug 2.
- 244.( ) Slip a 4" length of bare wire through S1D lug 1 to S1C lug 2 (NS). Cut the wire from S1D lug 1 to 1/2" and connect the free end to S1D lug 2. Solder S1D lug 1 and 2.
- 245.( ) Slip a 4" length of bare wire through S1C lug 4 to S1C lug 3 (NS). Cut the wire from S1C lug 4 to 1/2" and connect the free end to S1D lug 3 (S-1). Solder S1C lug 4.
- 246.( ) Slip a 4" length of bare wire through S1A lug 4 to S1A lug 3 (NS). Cut the wire from S1A lug 4 to 1/2" and connect the free end to S1B lug 3 (S-1). Solder S1A lug 4.

THE PRE-WIRING OF THE SELECTOR SWITCH S1 IS NOW COMPLETED.

## WIRING

- 247.( ) Remove two 1/8" lengths of outside insulation from a piece of green shielded cable. Slip one length over the free ends of the 220 $\mu$ mf ceramic disc capacitor C6 and the 100K ohm resistor R11. This will hold the ends of these components together. Similarly, slip the other 1/8" length of outside insulation over the free ends of capacitor C22 and resistor R47. Slip a 3/8" lockwasher (small pattern) over the shaft of the switch.
- 248.( ) Holding the switch in one hand, feed the free ends of the shielded cables through hole AP. Place the chassis with hole AP protruding beyond the edge of your bench or worktable, allowing the cables to fall freely as you lower the switch in position. As you lower the switch, guide each pair of leads (previously tied together with the 1/8" sleeving) into each lug of TP-16. See Pictorial 8. Mount the switch at the hole on the front panel, making sure the locating lug enters the special hole provided. Secure the switch with a 3/8" hex nut.
- 249.( ) Crimp the leads at TP16 lug 1 (NS) and TP-16 lug 2 (NS).
- 250.( ) Turn the chassis over and dress the grey/blue and grey/red shielded cables as shown in Pictorial 7, between the side of the chassis and the cable strap. Remove 1-1/2" of outer insulation from the free end of the grey/red shielded cable. Twist together the strands of shielding and tin. Cut the shield lead to 1/2". Remove 1/4" of insulation from the black and white leads.
- 251.( ) Connect the shield lead to J3 lug 2 (NS), the black lead to J2 lug 1 (NS), the white lead to J3 lug 1 (S-1). Refer to Pictorial 3 for phono jack numbering and Pictorial 7 for wiring.
- 252.( ) Remove 1-1/2" of outer insulation from the free end of the grey/blue shielded cable. Twist together the strands of shielding and tin. Cut the shield to 1/2". Remove 1/4" of insulation from the black and white leads. Connect the shield lead to J6 lug 2 (NS), the black lead to J5 lug 1 (NS), the white lead to J6 lug 1 (S-1).
- 253.( ) Cut a 20" length of 3-conductor grey/black shielded cable. Remove 1-3/4" of outside insulation from one end, twist the strands of shielding together and tin. Cut the shield lead to 3/4"; remove 1/4" of insulation from the brown, yellow and orange leads.
- 254.( ) Turn the chassis over and feed the unprepared end of this cable between the Selector Switch and TP-17 -- down through hole AP, leaving a sufficient length above the chassis for connection to the Selector Switch. See Pictorial 8.
- 255.( ) Remove the hex nut holding the switch, and, using care, move the switch a little distance away from the front panel, turning it slightly at the same time (counter-clockwise when facing the rear of the switch). Connect the yellow lead of the grey/black cable to S1A lug 1 (S-1); connect the brown lead to S1A lug 2 (S-2); connect the shield lead to TP-17 lug 2 (NS). Leave the orange lead temporarily disconnected.
- 256.( ) Cut a 16-1/2" length of 3-conductor grey shielded cable. Remove 1-1/2" of outside insulation from one end, twist the strands of shielding together and tin. Cut the shield lead to 3/4"; remove 1/4" of insulation from the brown, yellow and orange leads. Feed the unprepared end of the cable through hole AP in the same manner as the other cable, leaving sufficient length above the chassis for connection to the switch.
- 257.( ) Connect the yellow lead to S1C lug 1 (S-1); connect the brown lead to S1C lug 2 (S-2); connect the shield lead to TP-17 lug 4 (NS). Leave the orange lead temporarily disconnected.
- 258.( ) Push the switch back into position, securing it with the 3/8" hex nut.
- 259.( ) Connect the orange lead from the grey/black cable to S1A lug 5 (NS).
- 260.( ) Connect the orange lead from the grey cable to S1C lug 5 (NS).
- 261.( ) Connect one end of a 2" length of bare wire to TP-17 lug 2 (NS). Slip 1-1/4" length of sleeving over the wire and connect the free end to S1B lug 4 (S-1). See Detail B of Pictorial 8.

## WIRING

- 262.( ) Connect one end of a 2-1/8" length of bare wire to TP-17 lug 4 (NS). Slip a 1-3/8" length of sleeving over the wire and connect the free end to S1D lug 4 (S-1). See Detail B.
- 263.( ) Turn the chassis over and dress the cables between the side of the chassis and the cable strap as shown in Pictorial 7. Remove 2-1/4" of outside insulation from the free end of the grey/black shielded cable. Twist together the strands of shielding, cut to 3/4" and tin. Cut the orange lead to 1-1/8"; cut the yellow lead to 1-3/8"; cut the brown lead to 1-5/8". Remove 1/4" of insulation from these leads.
- 264.( ) Connect the shield lead of the grey/black cable to J7 lug 2 (S-2), the orange lead to J7 lug 1 (S-1), the yellow lead to J9 lug 1 (S-1), the brown lead to J8 lug 1 (S-1). Refer to Pictorial 3 for phono jack numbering and Pictorial 7 for wiring.
- 265.( ) Remove 2-1/4" of outside insulation from the free end of the grey shielded cable. Twist together the strands of shielding, cut to 3/4" and tin. Cut the orange lead to 1-1/8"; yellow lead to 1"; brown lead to 1-3/8". Remove 1/4" of insulation from all leads.
- 266.( ) Connect the shield lead to J10 lug 2 (S-2), the orange lead to J10 lug 1 (S-1), the yellow lead to J12 lug 1 (S-1), the brown lead to J11 lug 1 (S-1).

**Warning:** Check all connections to the phono jacks and make sure none of the leads or wires are touching any chassis parts or hardware.

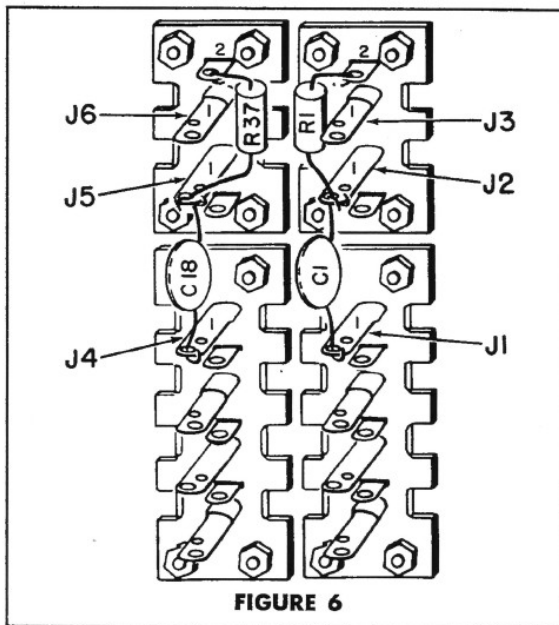

FIGURE 6

Refer to Figure 6

- 267.( ) Cut both leads of a 120 $\mu$ f ceramic disc capacitor C1 to 5/8". Connect from J2 lug 1 (NS) to J1 lug 1 (S-1).
- 268.( ) Cut one lead of a 56K ohm 1/2 watt resistor R1 (green-blue-orange-silver) to 1/2" and the other lead to 3/4". Connect the longer lead to J2 lug 1 (S-3), and the shorter lead to J3 lug 2 (S-3). Make sure this last connection (lug 2) does not bridge or short to the nut situated close to it.
- 269.( ) Cut both leads of a 120 $\mu$ f ceramic disc capacitor C18 to 5/8". Connect from J5 lug 1 (NS) to J4 lug 1 (S-1).
- 270.( ) Cut one lead of a 56K ohm 1/2 watt resistor R37 (green-blue-orange-silver) to 1/2" and the other lead to 3/4". Connect the longer lead to J5 lug 1 (S-3), and the shorter lead to J6 lug 2 (S-3).
- 271.( ) Turn the chassis over to make the following connections. Refer to Pictorial 8.
- 272.( ) Cut a 7-1/2" length of blue single conductor shielded cable. Remove 1-1/8" of outside insulation from one end, twist together the strands of shielding, cut to 3/4" and tin. Remove 1/4" of insulation from the center lead. Feed the other end of this blue cable through hole AP to the underside of the chassis, leaving a sufficient length on the topside for connection to the Selector Switch and TP-17. Connect the shield lead to TP-17 lug 4 (S-4), the center lead to S1C lug 3 (S-2). See Detail B.
- 273.( ) Turn the chassis over and remove 3/4" of outside insulation from the other end of the blue single conductor shielded cable. Cut off the shielding, remove 1/4" of insulation from the center lead. Connect to TP-13 lug 1 (S-3). See Figure 7.

WIRING

274. ( ) Turn the chassis over. Cut a 4" length of green single conductor shielded cable. Remove 1-1/8" of outside insulation from one end, twist together the strands of shielding, cut to 3/4" and tin. Remove 1/4" of insulation from the center lead. At the other end of the cable, remove 3/4" of outside insulation, cut off the shielding, remove 1/4" of insulation from the center lead. Feed the end of the cable with shield cut off through hole AP to the underside of the chassis.
275. ( ) At the end above the chassis, connect the shield lead to TP-17 lug 2 (S-4), the center lead to S1A lug 3 (S-2). See Detail B of Pictorial 8.
276. ( ) Turn the chassis over and connect the center lead of the free end of the green cable to TP-12 lug 5 (S-3). See Figure 7.

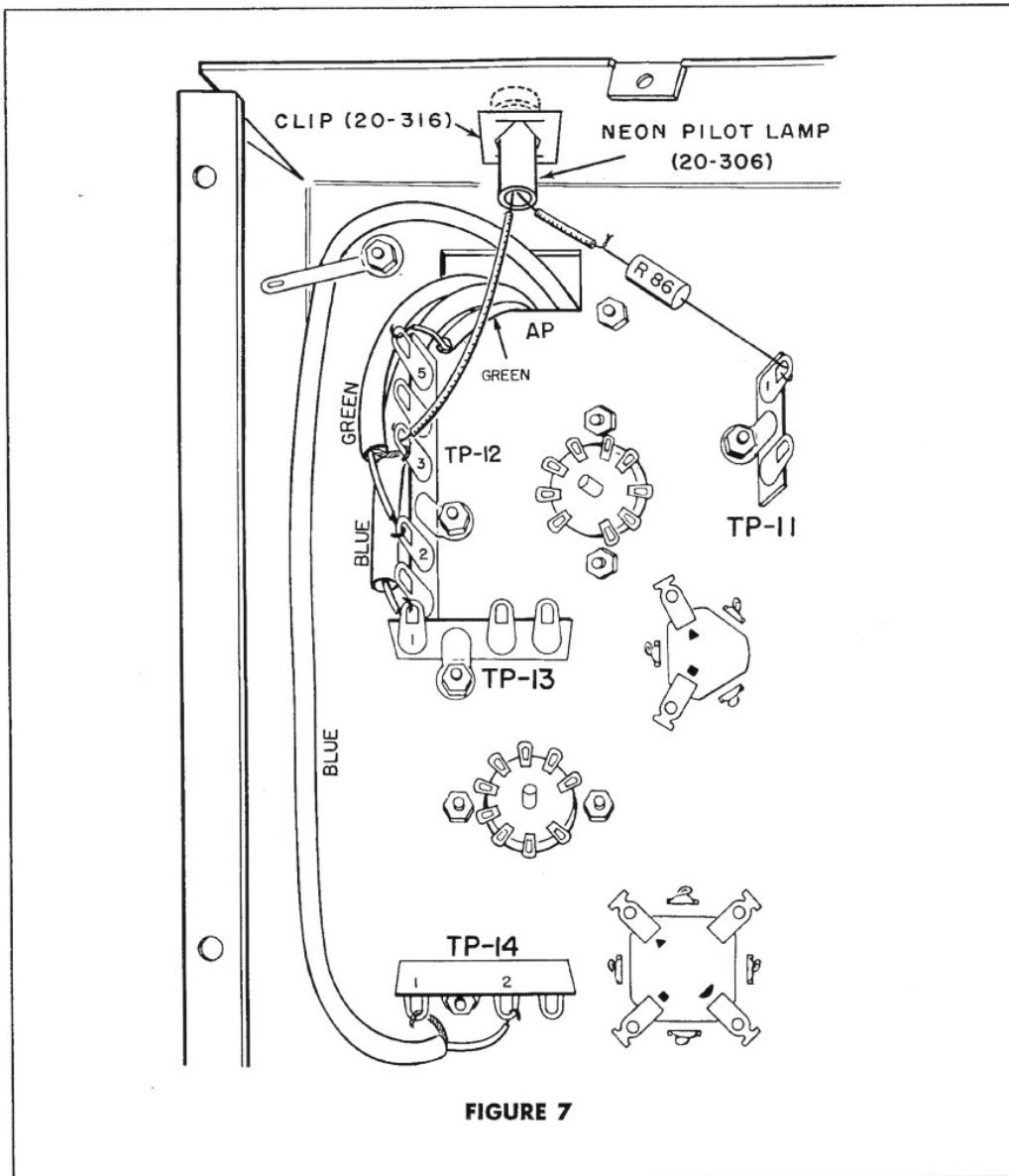

## WIRING

277. ( ) Cut a 7" length of green single conductor shielded cable. Remove 1" of outside insulation from one end, twist together the strands of shielding cut to 5/8" and tin. Remove 1/4" of insulation from the center lead. At the other end, remove 1" of outside insulation, twist the strands of shielding together, cut to 5/8" and tin. Remove 1/4" of insulation from the center lead.
278. ( ) Turn the chassis over, and feed one end of this green cable through hole AP to the underside of the chassis. Leave sufficient length above the chassis for connection to the Selector Switch: - Connect the shield lead to S1B lug X2 (S-2), the center lead to S1B lug X1 (S-2). See Detail B of Pictorial 8.
279. ( ) Turn the chassis over and connect the other end of the green cable, the shield lead to TP-12 lug 3 (NS) and the center lead to TP-12 lug 2 (S-3). See Figure 7.
280. ( ) Cut a 14" length of blue single conductor shielded cable. At one end, remove 1" of outside insulation, twist together the strands of shielding, cut to 5/8" and tin. Remove 1/4" of insulation from the center lead. Prepare the other end of the cable in exactly the same manner.
281. ( ) Turn the chassis over and feed one end of this blue cable through hole AP to the underside of the chassis, leaving a sufficient length above the chassis for connection to the Selector Switch. Connect the shield lead to S1D lug X2 (S-2) and the center lead to S1D lug X1 (S-2). See Detail B of Pictorial 8.
282. ( ) Turn the chassis over, and connect the other end of the blue cable, the shield lead to TP-14 lug 1 (S-4) and the center lead to TP-14 lug 2 (S-3). Dress this cable behind the cable strap. See Figure 7.
283. ( ) Turn the chassis over and solder TP-16 lug 1 (S-3) and TP-16 lug 2 (S-3). See Pictorial 8.
284. ( ) Cut the outside foil lead of a 0.15 $\mu$ f molded tubular capacitor, C7, to 1-1/8", and the other lead to 1/2". Connect the longer lead to S1A lug 5 (S-2) and the shorter lead to TP-17 lug 1 (S-2). See Detail C.
285. ( ) Cut the outside foil lead of a 0.15 $\mu$ f molded tubular capacitor, C23, to 1-1/8", and the other lead to 1/2". Connect the longer lead to S1C lug 5 (S-2) and the shorter lead to TP-17 lug 3 (S-2). See Detail C.
286. ( ) Check all connections to controls and switches on the front panel and make sure they are soldered.
287. ( ) Remove 1/8" of insulation from the black lead coming from the grommet hole beside the power transformer, and tin the wire end. Slide the wire end between the open clamps of the spade lug (part #20-120). Allow the insulation of the lead to slip under the first clamp of the lug. Using pliers, close the clamps tightly over the lead. Apply solder.

Refer to Figure 7

288. ( ) Select the pilot lamp (20-306) and clip (20-316). Slip the lamp into position from the front of the chassis. Exerting pressure on each side of the clip with the thumb and forefinger of one hand, slide the clip over the body of the lamp and press the clip forward as far as it will go. Hold the lamp securely from the front of the chassis with the other hand while doing this. Make sure the lamp is securely held by the clip before proceeding.
289. ( ) Slip a length of sleeving over one bare lead of the pilot lamp, leaving 1/4" of bare wire end exposed. Connect this end to TP-12 lug 3 (S-6).
- Note: Make sure the two wire leads are not twisted together inside the body of the neon lamp.
290. ( ) Cut one lead of a 270K ohm 1/2 watt resistor, R86 (red-violet-yellow-silver) to 1", and the other lead to 3/8". At the 3/8" end, form a small loop but leave unconnected temporarily. Connect the other (1") end to TP-11 lug 1 (S-3).
291. ( ) Cut the remaining wire lead of the pilot lamp to 1-1/8" length. Slip a 7/8" length of sleeving over it, then connect to the loop in the wire lead of R86 and solder.

## WIRING

292. ( ) Refer to Figure 8 which shows the mounting of the line cord and strain relief. Insert the line cord (#20-199) into the one-piece strain relief (part #20-3), allowing the stripped end of the cord to project 2" beyond the strain relief (A). Clamp together as shown in B, and feed the stripped end of the cord through hole AQ (next to TP-1). Press the strain relief into this hole until it snaps in place (C). Cut the bare wires at the stripped end of the cord to 1/4" in length. Connect one wire to lug 2 (S-2) of the AC receptacle, and the other to TP-1 lug 1 (S-2). See Pictorial 7 for wiring.
293. ( ) Loosen slightly the screw securing TP-1 and twist the terminal post in a counter-clockwise direction, so that it presses against the strain relief. Tighten the screw again. This will prevent accidental shorting of the lug to the bottom plate when it is mounted.
- 293a ( ) Special Soldering Step:  
Before proceeding with the next step, apply solder to all four twisted ground lugs of C37. Use sufficient heat and solder to ensure a good electrical connection between each lug and chassis.
294. ( ) Insert the 4 amp fuse (part # 20-186) into the fuseholder on the underside of the chassis.
295. ( ) Insert the 9 tubes in their respective sockets. (Match the tube markings with the designations on the chassis). Take care not to damage the pins when inserting the tubes. Make sure the blank space between pins matches up with the similar space on the tube sockets.
296. ( ) Install tube shields (part #20-173) over tubes V1, V2 and V6.

Refer to Pictorial 9

297. ( ) Carefully, remove the five hex nuts securing the controls to the front of the chassis.
- Select the escutcheon and install it carefully on the front of the chassis, allowing the slide switch knobs and control shafts to pass through their assigned holes in the escutcheon. Secure the escutcheon firmly by means of the control hex nuts previously removed.
- Note: As each hex nut is tightened, make sure the locating tab on the control enters the small hole provided for it in the front of the chassis so that the control will not turn in operation.
298. ( ) Select all the metal control knobs. Turn the outer concentric shafts of the BASS, TREBLE, and VOLUME-BALANCE controls to their mid-positions. Install three large panel knobs on the outer concentric shafts of these controls so that the indicating line on each knob is in the 12 o'clock position. Install three small knobs on the inner shafts of these controls with the set screws tightened against the flats of the shafts (use a small screwdriver with a 3/32" blade). Install the two large knobs on the shafts of the SELECTOR and SEPARATION controls with the set screws tightened against the flats of the shafts.

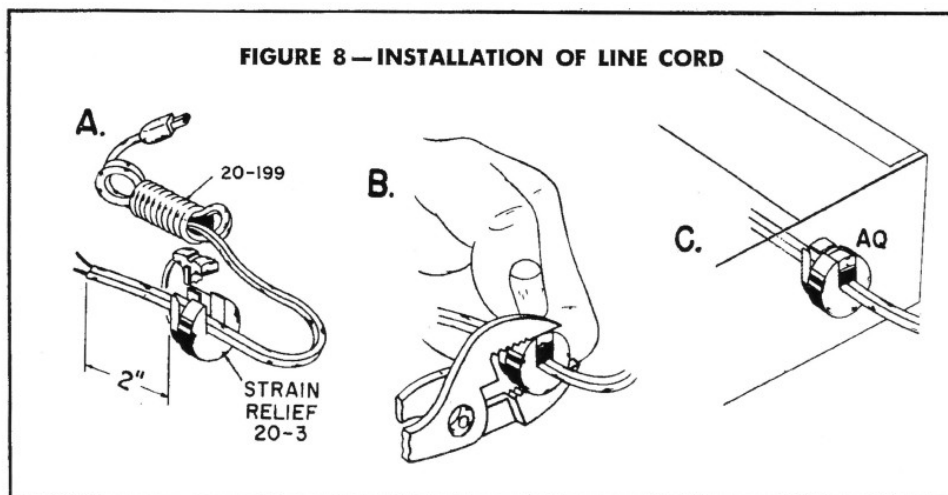

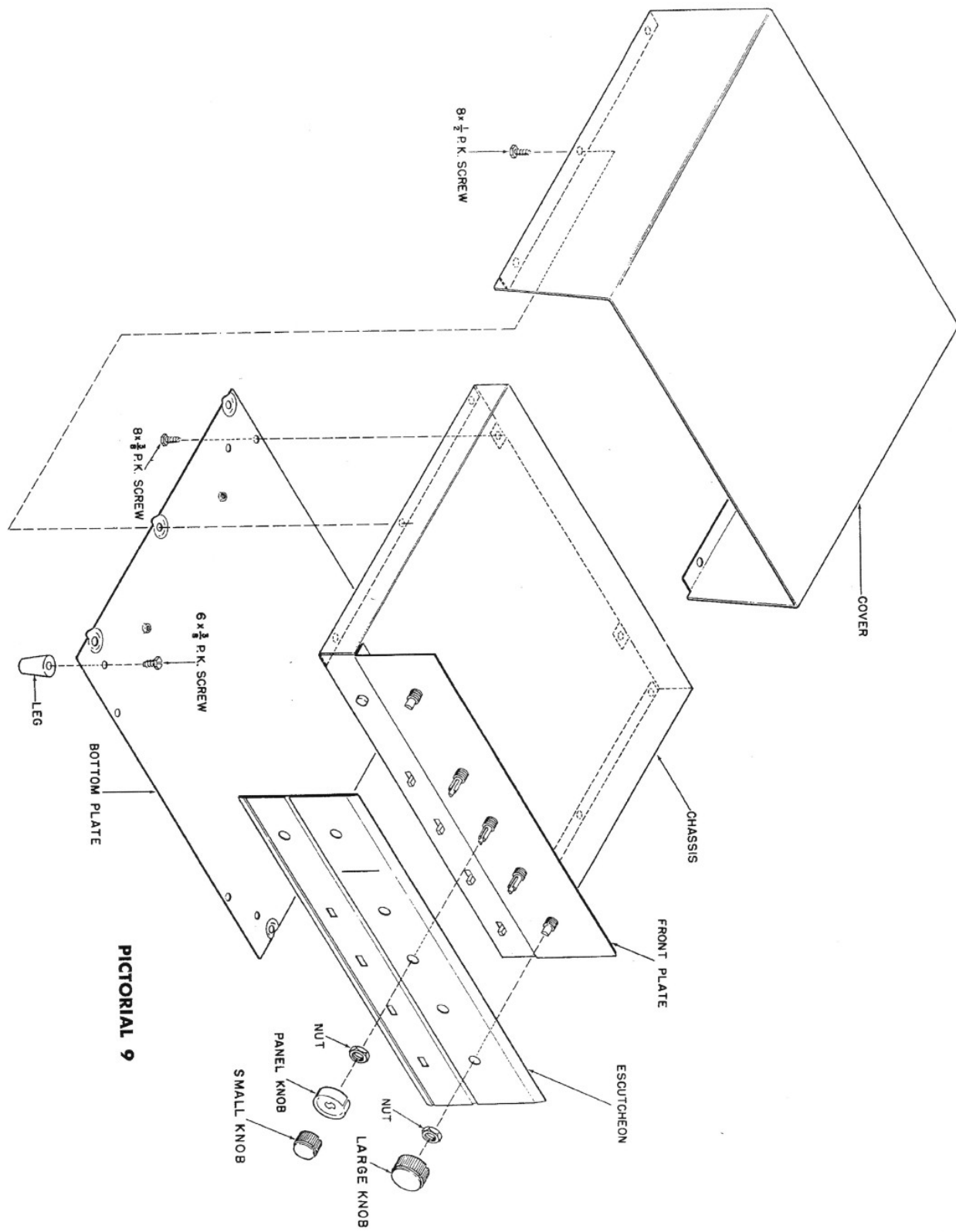

**PICTORIAL 9**

## PRELIMINARY CHECKS

The construction of your KT-250 is now completed. Before proceeding any further, check over the wiring carefully to make sure that you have not made any errors or have left any connections unsoldered. If possible, have a friend check the construction with you, as there is a tendency for a person to repeat his errors. We recommend that you make the following DC resistance measurements before plugging the amplifier into the power line.

Turn the Separation control in a clockwise direction to operate the On-Off switch.

1. Check for a resistance of approximately 2 ohms between the prongs of the AC plug.
2. Check for a resistance of approximately 5000 ohms from C35 lug 1 to ground (chassis). Allow sufficient time for the capacitors to be charged by the ohmmeter battery.
3. Check the resistance from one of the prongs of the AC plug to chassis for a reading of infinity (over one million ohms).

Any large variation (over 20%) from these values should be considered abnormal. DO NOT plug in the amplifier until the cause has been determined and the fault corrected.

## BIAS AND BALANCE ADJUSTMENTS

Before operating the KT-250, the following bias and balance adjustments must be made. This procedure will provide optimum operation of the output stages of the amplifier.

If any of the output tubes are replaced or interchanged, the channel which is affected must be rebalanced for continued optimum performance. It may also be advantageous to check these adjustments approximately every three months.

These adjustments can more easily be made by placing the amplifier on its side with the power transformer and the three electrolytics closest to the workbench or table top. Placing some object (such as pliers) beneath the power transformer will increase the stability of the amplifier in this position.

Caution: Do not make any adjustments without first connecting a speaker or equivalent load to each of the speaker output terminals.

### DO NOT PLUG IN THE AMPLIFIER UNTIL INSTRUCTED TO DO SO.

Cut a piece of electrical tape (Scotch Tape will do) and temporarily wrap it around the silicon diode SR2 (see Pictorial 7 for location of this component). This will prevent accidental contact between the meter probe and this component when measurements are taken from pin 3 of V5 during the bias and balance adjustments. Use sufficient tape to completely cover SR-2 and its terminating wires.

- A. Turn both BIAS controls (inner shafts) fully clockwise, and the BALANCE controls (outer knurled shafts) to their mid-position.
- B. Set Volume-Balance controls fully counter-clockwise (minimum volume); Bass and Treble controls to their "flat" position (indicator bars in a 12 o'clock position); A Amplifier Slide Switch to "A", B Amplifier Switch to "B"; Selector Switch to "AUX".
- C. Plug in the amplifier. Use an outlet which furnishes 110-120 volt AC, 50/60 cycles.
- D. Turn the Separation control clockwise just beyond the point where the On-Off switch operates. The neon lamp will light after a short delay. Make sure all filaments in the tubes are lit.

### CHANNEL A:

1. Using the lowest range of a Voltmeter on which 0.5 volts DC can be read, measure the voltage from pin 3 of V5 to ground (chassis). Adjust the Bias control to give a reading of 0.3 volts.
2. Measure from pin 3 of V4 to ground. Make a note of this reading.
3. Now adjust the BALANCE control for a value midway between the reading in Step 2 and 0.3 volts.
4. Now adjust the BIAS control for a value of approximately 0.48 volts.

### CHANNEL B:

1. Measure from pin 3 of V9 to ground. Adjust the BIAS control to give a reading of 0.3 volts.
2. Measure from pin 3 of V8 to ground. Make a note of this reading.
3. Now adjust the BALANCE control for a value midway between the reading in Step 2 and 0.3 volts.
4. Now adjust the BIAS control for a value of approximately 0.45 volts.

CHANNEL A: Recheck from pin 3 of V5 to ground and pin 3 of V4 to ground for a reading of 0.45 volts. If both readings are identical but incorrect:- Adjust the BIAS control to provide 0.45 volts from either tube.

If readings are unequal:- Adjust the BALANCE control for a value mid-way between the two readings, measuring from either tube. Repeat this procedure until the readings at V4 and V5 are identical. When this has been accomplished, adjust the BIAS control for a reading of 0.45 from pin 3 of either V4 or V5.

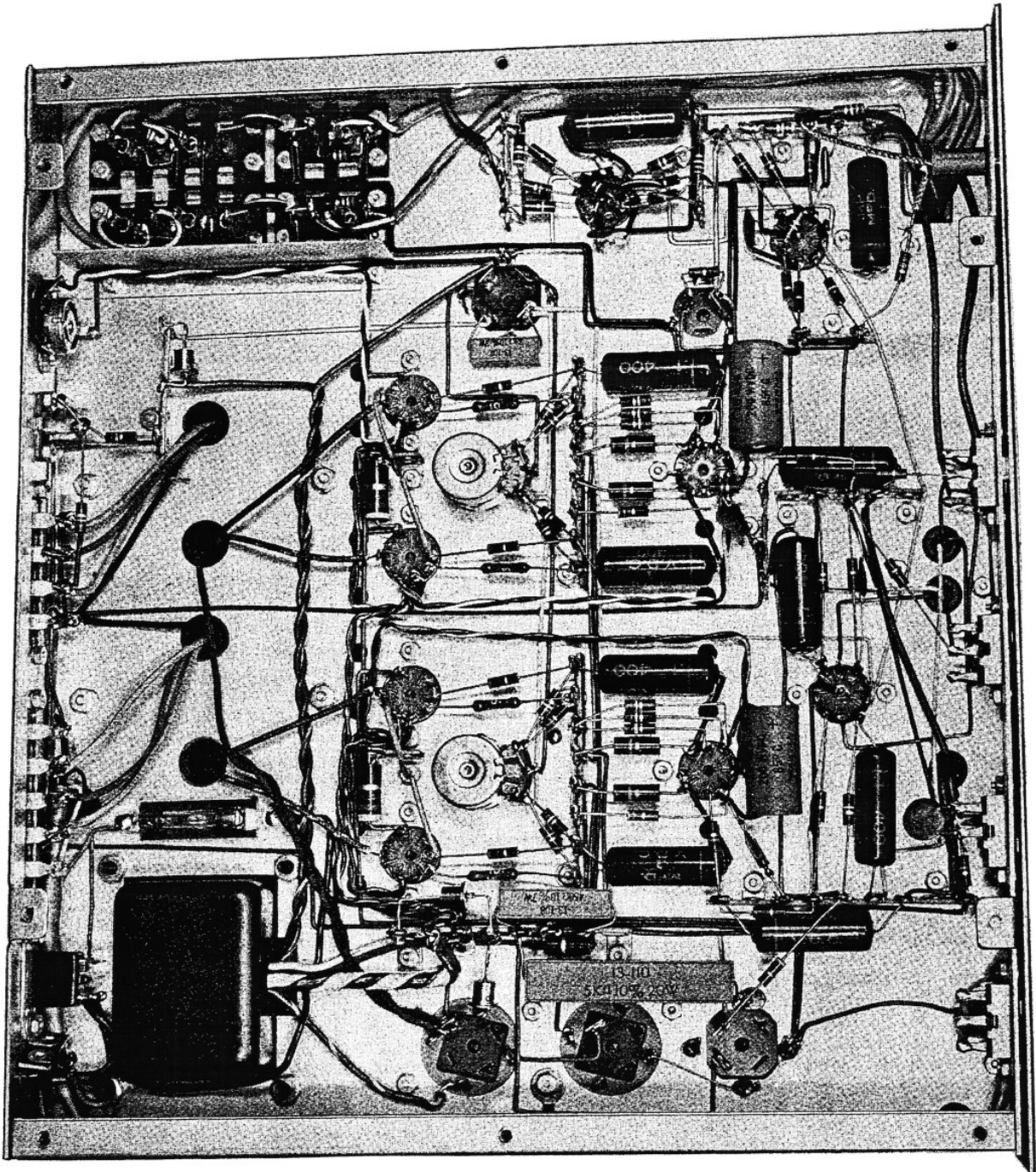

COMPLETED WIRING — UNDERCHASSIS VIEW

## COMPLETED WIRING — TOPCHASSIS VIEW

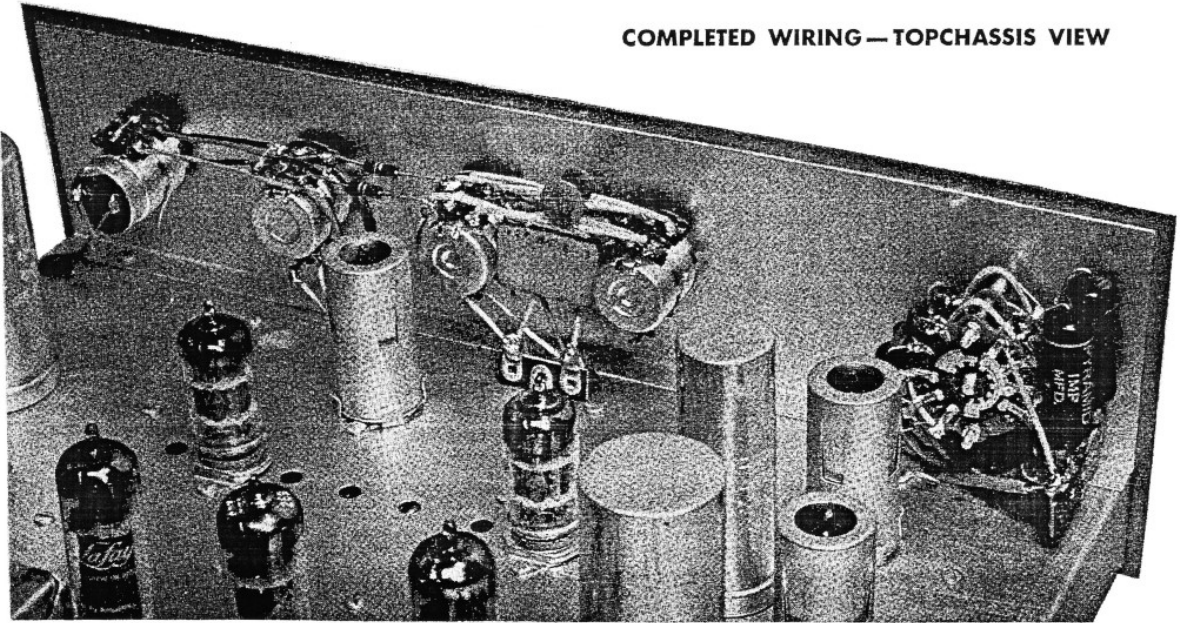

CHANNEL B: Recheck from pin 3 of V9 to ground and pin 3 of V8 to ground for a reading of 0.45 volts. If both readings are identical but incorrect; - Adjust the BIAS control to provide 0.45 volts from either tube. If readings are unequal; - Adjust the BALANCE control for a value mid-way between the two readings, measuring from either tube. Repeat this procedure until the readings at V8 and V9 are identical. When this has been accomplished, adjust the BIAS control for a reading of 0.45 V. from pin 3 of either V8 or V9. At this point, it is suggested that the amplifier remain in operation for a period of several hours, after which, the readings from pin 3 of V4, V5, V8 and V9 to ground should be rechecked for a value of 0.45 volts. Readjust the BIAS and BALANCE controls to this figure if necessary. When all adjustments have been completed, turn the power switch off and unplug the amplifier. Remove the tape from around SR2.

### FINAL ASSEMBLY

If you intend to panel-mount the amplifier in a cabinet, proceed to the section under CABINET MOUNTING

If you intend to place the amplifier on a shelf, proceed to the next step.

Refer to Pictorial 9

1. ( ) Mount the four molded legs at the four holes in the bottom plate (one at each corner) as shown in Pictorial 9. Use a #6 x 3/8" PK screw to secure each leg firmly (do not overtighten).
2. ( ) Attach the bottom plate to the amplifier chassis using four #8 x 3/8" PK screws. These screws should be secured to the four protruding tabs at the bottom of the chassis.
3. ( ) Slide the cover onto the amplifier from the rear, until the front edge of the cover comes to rest against the escutcheon. Extend the AC line cord to prevent obstruction as the cover is installed. Secure the cover to the underside of the amplifier by means of six #8 x 1/2" PK screws (three each side).

This completes the assembly of the amplifier. Turn to the section which describes how the associated equipment (record player, tuner, loudspeakers, etc.) is connected to the amplifier.

### CABINET MOUNTING

Careful consideration must be given to the problem of ventilation in any cabinet-mounted installation. A cabinet with an open back will always provide the best ventilation. If a closed back is used, be sure to provide several large openings in the back, as high up and as low down as possible. For effective ventilation, provision must always be made in the cabinet for cool air to enter and hot air to leave.

The KT-250 may be mounted behind panels of any thickness (1/4" or 1/2" thicknesses are the most commonly used). The cabinet should contain a shelf to support the amplifier as shown in Figure 9. Remove the back cover of the cabinet (if so equipped) before beginning the installation.

1. If you were previously using the amplifier in the open, remove the bottom plate and the cover. Also, detach the four legs from the bottom plate.
2. Attach the bottom plate (without legs) to the bottom of the amplifier. Use six #8 x 1/2" PK screws to secure it. Use the six holes located in the bumped-out portions of the bottom plate.
3. Remove all control knobs and then the escutcheon (held by the five control hex nuts). When this is done, the amplifier is ready for insertion into the cabinet.
4. A full-scale mounting template has been provided on a separate insert. Use the upper half of this template to make the rectangular cut-out in the cabinet front panel. Use the lower half of the template to make the four 1/4" diameter holes and vent cut-out in the support shelf. Note that their distance from the inside of the cabinet front panel depends upon the thickness of the panel.
5. Carefully, slide the amplifier forward into the cut-out from the rear of the cabinet (see side view in Figure 9), allowing the front of the chassis to come through as far as possible.
6. Install the escutcheon onto the front of the chassis, allowing the slide switch knobs and control shafts to pass through their assigned holes in the escutcheon. Secure the escutcheon firmly by means of the hex nuts previously removed.

**Note:** As each hex nut is tightened, look into the chassis and note whether the locating tab on the face of the control is entering the small hole provided for it in the front of the chassis (this will prevent the control from turning).

7. Push the amplifier back into the cut-out so that the escutcheon rests against the front of the cabinet panel (in the position illustrated in Fig. 9).
8. Slip a #8 x 1/2" washer over each of four 8-32 screws. You have been supplied with screws of two lengths -- 1" and 1-1/4". If the support shelf is 1/2" thick, use the 1" screws; if the shelf is 3/4" thick, use the 1-1/4" screws.

Use these four screws to secure the bottom of the amplifier to the support shelf, as shown in Fig. 9.

9. Refer back temporarily to Step 298 on page 42 (and Pictorial 9) and install all control knobs as indicated.

This completes the cabinet mounting. Turn to the section which describes how the associated equipment (record player, tuner, loudspeakers, etc.) is connected to the amplifier.

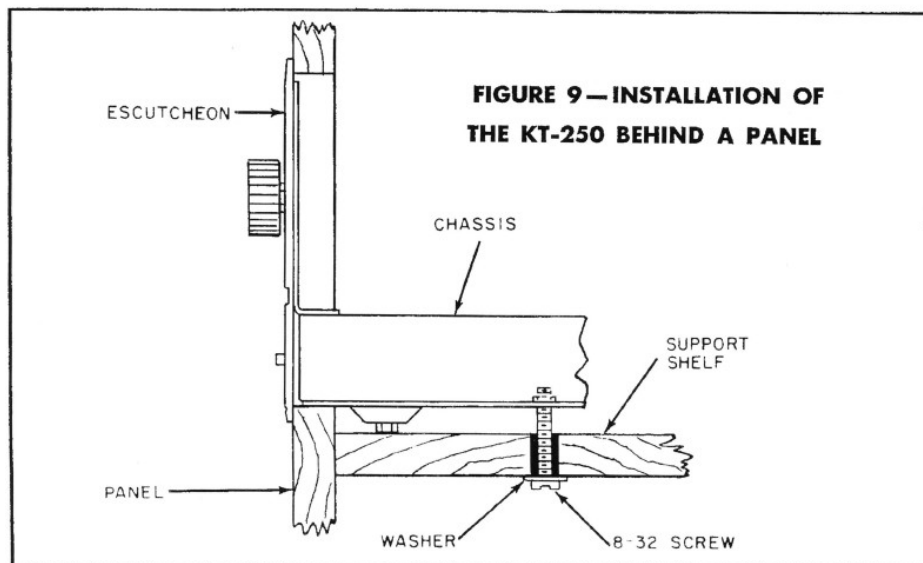

## LOUDSPEAKER CONNECTIONS

**Warning:** Do not operate the KT-250 without first connecting a speaker or equivalent load to the speaker output terminals.

The amplifier has output terminals for connection to speaker systems of 4, 8 or 16 ohms impedance.

**CHANNEL A SPEAKER:** Connect one lead of this speaker system to the extreme left-hand terminal, and the other lead to the extreme right-hand terminal of the channel A output strip. Connect the lead terminated with a spade lug to the terminal with a number corresponding to the impedance of your speaker system.

**CHANNEL B SPEAKER:** Connect one lead of this speaker system to the C terminal of the Channel B output terminal strip, and the other lead to the terminal with a number corresponding to the impedance of your speaker system.

Note: Figure 10 shows speakers of 16 ohms impedance connected to the amplifier. Speakers of 8 or 4 ohms impedance should be connected as indicated above.

For indoor installations, ordinary plastic-covered lamp cord can be used to connect speakers to the amplifier, and may be extended as far as 50 ft. without any significant power loss. TV antenna lead may be used for shorter distances, and is especially convenient for installation under a rug.

**THIRD SPEAKER:** The BRIDGED OUTPUT jack located at the rear of the amplifier may be used to feed a third monophonic power amplifier and speaker placed between the left and right channel speakers. This enables a wider sound spread to be obtained by moving left and right channel speakers further apart, the third speaker effectively eliminating any "hole in the middle" effect which might result. Alternatively, the third speaker may be used for monophonic listening to stereo signals as, for example, in a room other than the one in which the stereo system is being used. The level at this output jack is determined by the setting of the VOLUME-BALANCE controls. If individual adjustment of this sound output is desired, it must be made at the third amplifier.

**Monophonic Operation:** The dual 4, 8 and 16 OHM impedance terminals may be paralleled for connection of single speaker systems of up to 8 ohms. For example, parallel the 16 ohm terminals for use with an 8 ohm speaker, the 8 ohm terminals for use with a 4 ohm speaker.

Note: The Phase switch should be placed in the "Normal" position when paralleling the outputs in this way.

**AC POWER:** The KT-250 is to be used on 105-125 volts, 50-60 cycles AC only. An AC utility outlet for connecting the line cord of another component, normally a tuner, is provided on the rear of the unit. This outlet is controlled by the on-off switch on the amplifier; turning on the KT-250 automatically supplies power voltage to any component whose line cord is plugged into this outlet, but is not protected by the fuse on the amplifier. Do not use this outlet for a record player - an unswitched outlet is recommended for this type of component. Turning off the KT-250 will not then also turn off the player while its idler wheel is engaged because its own power switch still happens to be on. In this manner, flat spots will be prevented from developing on the idler wheel. The power drawn from this outlet by any accessory component should not at any time exceed 350 watts.

## CONNECTIONS TO ASSOCIATED EQUIPMENT

### PHONOGRAPH

The shielded leads from your phono arm should be provided with phono-type plugs for connection to the amplifier. To avoid loss in high frequency, these leads should not exceed 10 feet in length.

**Low Level Phono Inputs:** Inputs from a magnetic or variable reluctance (constant-velocity type) cartridge should be connected to the jacks designated "MAG PHONO". The termination at these jacks is 50,000 ohms. This value correctly loads most cartridges for flat frequency response. Should a cartridge be used where the manufacturer recommends a different load for flat response, remove the 56K ohm resistor connected across the MAG jacks and replace with a resistor, the value of which can be determined from the following:

$$R_x = \frac{(470,000)(R_{term})}{470,000 - R_{term}}$$

$R_x$  is the desired resistor value.  $R_{term}$  the recommended terminating load.

**High Level Phono Inputs:** Inputs from "constant-amplitude" phono cartridges such as crystal, ceramic and FM-capacitance types, should be connected to the jacks designated "CER XTAL".

In addition, crystal and ceramic cartridges may also be plugged into the "Aux" jacks.

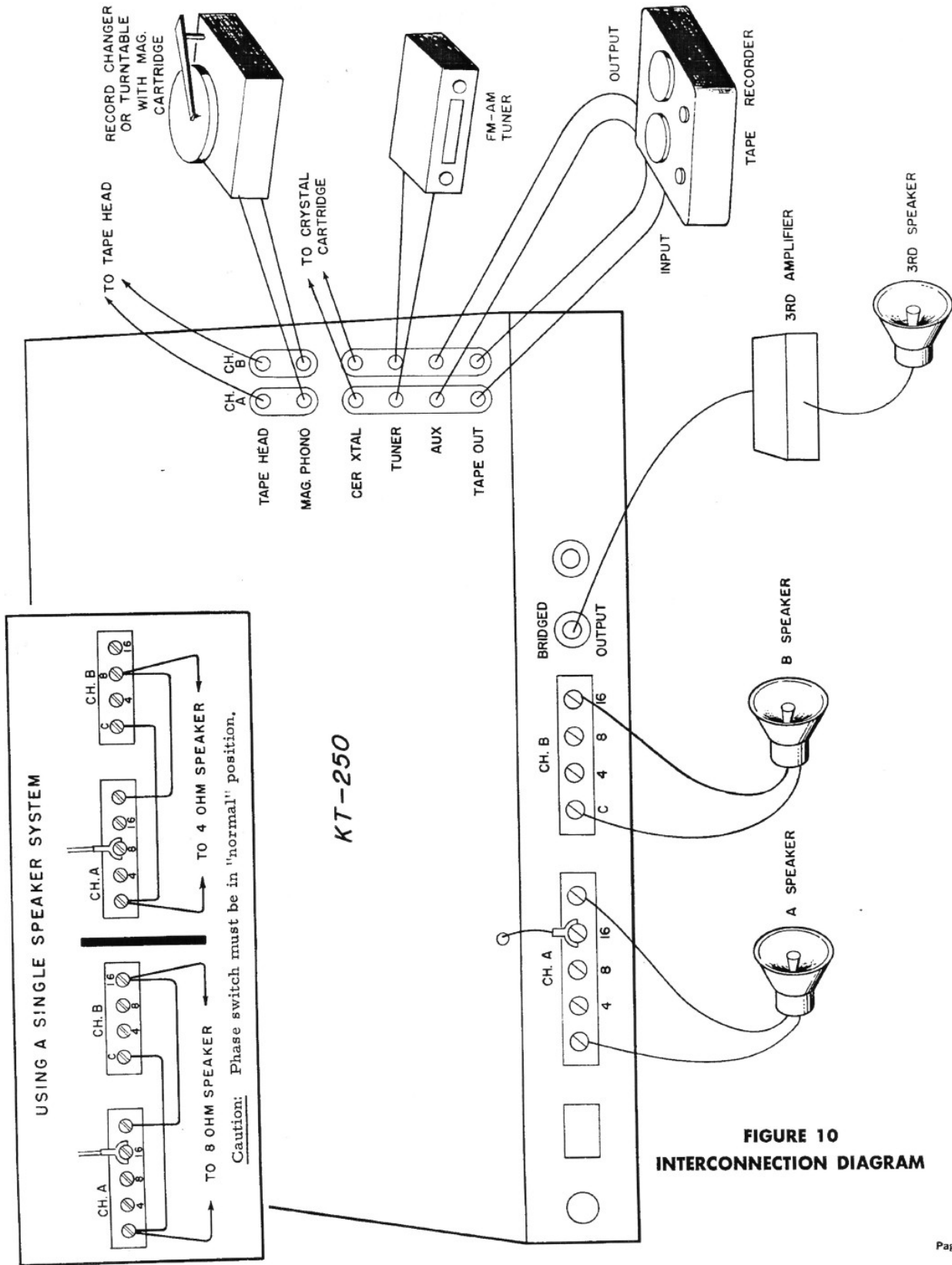

## TUNER

The input jacks designated "TUNER" are for use with FM or AM tuners, FM Multiplex adapters, TV receivers and other equipment with at least 0.7 volt output. Shielded leads complete with phono-type plugs should be used to connect any of these sources to the amplifier.

Stereo Sources: The output of a stereo FM-AM tuner should be connected as follows: FM output into the A tuner input jack, AM output into the B tuner input jack of the same pair. When using a multiplex adapter (FM-FM), connect the two output leads of the adapter to the A and B tuner input jacks.

Monophonic Sources: Monophonic outputs from Radios, Tuners or TV receivers may also be connected to the "TUNER" jacks. For example, an AM tuner could be connected to the A input jack and the sound output of a TV receiver connected to the B input jack. Selection of either of these would be carried out by means of the "Selector" and "Slide" switches on the front panel of the amplifier. (All controls and their use are fully explained in the section on "Operation").

The jacks labelled "AUX" may also be used for inputs from Radios, Tuners and TV receivers etc., either singly from monophonic sources, or as a pair for stereo inputs.

Note: In all cases, careful adjustment of levels must be made at the Tuners, TV receivers, etc., in order not to overload the KT-250.

## TAPE RECORDER

To play back directly from the playback head of a tape player, connect the leads from the tape heads through shielded cables and phono-type plugs into the input jacks labelled "TAPE HEAD". The termination provided in the KT-250 is 470K ohms, a value that is suitable for most modern tape heads. If the tape recorder signal goes through a tape preamplifier, do not connect it to these jacks. The output of a tape preamplifier should be connected to the high level input jacks labelled "AUX". To avoid overloading the KT-250, make use of the level controls available at the tape pre-amp. For recording purposes, use the output at the "TAPE OUT" jacks, which should be connected to the recorder input by means of shielded cables. All sources connected to the KT-250 and selected by the SELECTOR Switch, are available at these jacks. Listening to the original program material is possible, adjustment of the amplifier tone or volume controls having no effect on the signals at the TAPE OUT jacks.

## **OPERATION**

Before attempting to operate the amplifier, be sure all connections have been made in accordance with the instructions given earlier in this manual, and according to directions given by the manufacturer of the other components.

Under normal operation the power transformer will become very hot. This is a normal condition and need not cause any concern. However, it is important that adequate ventilation be provided for the amplifier. The unit is well ventilated in itself, but sufficient space should be allowed around it to permit free air flow at all times. NEVER place books or other objects on top of the amplifier, since covering the perforated cover will restrict ventilation. Failure to observe these precautions will result in sharply reduced component and tube life.

POWER SWITCH. The amplifier is turned on by rotating the SEPARATION control clockwise, just beyond the point where the switch operates. After a slight delay, the neon pilot lamp will light.

SELECTOR. This switch selects signals connected to the input jacks. The "Phono" setting selects signals connected to the "Mag Phono" and "Cer/Xtal" inputs and it is therefore not desirable to have equipment connected to both of these pairs of jacks. The remaining positions of the switch, "Aux", "Tuner" and "Tape Head", select signals connected to the corresponding input jacks on the amplifier.

At every position of the switch, all unused inputs are shorted for zero cross-talk - except for the "Aux" input. A special purpose is served by omitting this input from the automatic shorting process. During a tape recording operation, the output of the tape recorder would normally be connected to the "Aux" input. The selector switch would, of course, be in either the "Phono", or "Tuner" positions to select the recording source. Shorting the "Aux" input would in effect place a short across the tape recorder output, which, although not being used, might nevertheless have a detrimental effect on the recording operation.

SLIDE SWITCHES, (A Amplifier and B Amplifier) The positions of these two slide switches determine the manner in which signals (previously selected by the SELECTOR switch) will go through the amplifier. Various modes of operation and their required switch settings are given below, in addition to a quick-reference table.

**Normal Stereo:** Setting the A Amplifier switch to the "A" position and the B Amplifier switch to the "B" position provides normal stereo operation. In this manner, channel A input signals are controlled and amplified through the channel A amplifier, the channel B input signals through the channel B amplifier.

**Reverse Channel:** Setting the A Amplifier switch to the "B" position and the B Amplifier switch to the "A" position reverses the operation described for normal stereo. Effectively reversing the positions of the two speakers in the room, it is intended to provide a means of suiting individual tastes in listening as regards the relative positions of instrumental groupings.

**Monophonic A:** Setting both the A and B Amplifier switches to the "A" position allows signals connected to the channel A input jacks to be controlled and amplified through both amplifiers and speakers.

**Monophonic B:** Setting both A and B Amplifier switches to the "B" position performs the same function for channel B signals (B signals through both amplifiers and speakers).

<u>Ch. A. Amp.</u> <u>Switch</u>	<u>Operation</u>	<u>Ch. B. Amp.</u> <u>Switch</u>
A	Normal Stereo	B
B	Reverse Channel	A
A	Monophonic A	A
B	Monophonic B	B

**NOTE:** When playing a monophonic record with a stereo cartridge, set the A Amp switch to A, the B Amp switch to B and the SEPARATION CONTROL to its fully clockwise position. This method has the advantage of cancelling out the vertical rumble component.

**BASS AND TREBLE.** These two dual concentric controls provide separate and independent tone control for each channel, either increasing or decreasing the relative strength of the bass and treble range. When the indicators on the knobs are set to be vertical (12 o'clock), response of the amplifier is flat. Clockwise rotation increases bass or treble response, and counter-clockwise rotation provides a reduction. The "panel" knobs (large diameter) control channel A, the "outer" knobs channel B.

**SEPARATION.** The AC power off-on switch is located on this control. Turning the control clockwise operates the switch and supplies power to the KT-250. In the extreme counter-clockwise position (without turning power off), complete channel separation is obtained. Advancing the control clockwise gradually reduces the amount of separation, until, in the fully clockwise position, both channels are fully mixed, with a resultant monophonic output. This control may be used to eliminate exaggerated channel separation found in some stereo source material, or to compensate for speakers that have been installed too far apart. It also permits two channel mixing in the extreme clockwise position (Mon), by blending a monophonic signal inserted into an A input with one inserted into the B input of the same pair. An example of this would be the blending of a voice with a musical program for announcements, or for playing a monophonic record with a stereo cartridge.

**Note:** The signals at the TAPE OUT jacks are completely independent of this mixing feature which takes place in a succeeding stage in the amplifier.

**VOLUME-BALANCE.** This is a dual concentric clutch-operated control which acts as an independent level control for each channel when unclutched, or as a master gain control for both channels when clutched. To unclutch the controls, simply pull the small outer knob outward until a "click" is heard. Each knob may then be operated individually, without affecting the setting of the other. The "panel" knobs (large diameter) control channel A, the "outer" knobs channel "B". Balancing of channels can be carried out by ear or, if greater accuracy is desired, by the use of VU balance meters connected to the speaker output terminals. When this procedure has been completed, the controls should be clutched by pushing the outer knob in again.

LOUDNESS. This switch, when "on", provides the frequency response changes required by the ear at low listening levels, and permits the VOLUME-BALANCE control to function as a compensated loudness control.

PHASE. In the "REV" (Reverse) position of this switch, the phase of channel A is reversed electrically. This action effectively reverses the leads to the channel A speaker in the event that, during connection, the two speakers were connected out of phase. Additionally, the program material itself may have a phase reversal due to incorrect recording or duplicating. To determine the best position of this switch, play a monophonic record containing heavy bass passages (with slide switches set for normal stereo and separation control fully clockwise). Set the switch in the position which offers the greatest reinforcement of bass response. Since this position is usually considered "normal", interchange the two leads of one (only) speaker if the reinforcement occurred while the switch was in the "Rev" position. Thereafter, the switch should be left in the "Normal" position, unless it is discovered that the phase of one of your program sources has been reversed.

HUM BALANCE. The hum balance control located at the rear of the amplifier enables you to minimize any hum that may exist within the amplifier after associated equipment has been connected. The Selector switch should be set to either "Tuner" or "Aux" to select equipment connected to either of these high level input jacks. Turn the Volume-Balance control to its fully clockwise position. Bass and Treble controls should be set to their "flat" position, and all other controls set for normal stereo operations. Using a screwdriver, adjust the HUM BAL control for minimum hum.

### **EXCESSIVE HUM**

Excessive hum encountered during phono operation may be isolated in the following manner.

Disconnect the phono input cable from the amplifier and short the phono input jack to chassis. If the hum disappears, the trouble is not in the amplifier but in the phonograph or in the connection to the amplifier. Excessive hum encountered during any other operation of the amplifier may be isolated in a similar manner. Disconnect the input cable in question and short the particular input jack to chassis. As before, if hum disappears, the trouble is external to the amplifier. If these tests indicate that the fault lies within the amplifier, refer to "IN THE EVENT OF DIFFICULTY".

External Hum: While it is not feasible to list every possible cause of hum in a system, the following notes on the more common causes may enable you to locate and remedy the trouble. If the hum occurs on Phono, it may be due to lack of grounding of a metal pickup arm, in which case a good single ground connection to the cable shield from turntable frame, pickup arm, and cartridge case should be made. Hum which is present only when the phono motor is operating, and which varies as the pickup arm is moved across the turntable, is usually direct pickup by the magnetic cartridge from the phono motor. Using a rubber mat on the turntable will increase the separation of the cartridge from the motor. Hum can be induced in the magnetic cartridge from a power transformer or other magnetic field in the vicinity. Moving the phonograph away from the suspected source will normally cure the trouble. Always make sure that the phono input cable shielding is grounded to the amplifier chassis at one point only through the skirt of the input plug where it connects to the amplifier.

AC Line Cords: As a general means of reducing hum, the following procedure should be carried out.

1. Turn on all equipment connected to the amplifier.
2. Reverse the AC wall plug from the amplifier to determine which position provides the least hum. Leave in this position.
3. Repeat this procedure with the AC plugs of the other components, using the amplifier selector switch to select the component being tested.

Making a single ground connection between the amplifier and a ground point (such as the AC socket wall plate) may further reduce hum. The ground wire should be taken to a point as close to the input jacks of the amplifier as possible.

## IN THE EVENT OF DIFFICULTY

- A. Carefully re-check all wiring and values of components inserted against the instructions. If you have not already done so, trace each lead and component in the pictorials with a colored pencil. It is frequently helpful to have a friend check your work with you as there is a tendency for the constructor to repeat his errors.
- B. Inspect all solder connections carefully. A large number of kits returned for repair have been found defective due to poor solder connections. Therefore, any doubtful connections should be re-heated to make sure they are correctly soldered.
- C. Check for small pieces of solder or wire which may have fallen into the chassis. Make sure that the use of excess solder has not caused a short between adjacent terminals or nearby wiring, particularly on tube sockets and switch terminals.
- D. If you are still unable to locate the trouble and a voltmeter is available, check the voltage readings, referring to the voltage chart. A variation of  $\pm 15\%$  may be considered normal.

**CAUTION: EXERCISE GREAT CARE WHEN MAKING ANY CHECKS WITH THE UNIT TURNED ON.** If any voltage is incorrect, recheck that part of the circuit involved carefully. If the wiring and connections have already been checked and found correct, the trouble will in all probability be due to a defective part (tube, capacitor, resistor, etc.).

If there are obvious signs of a short circuit (components becoming discolored or smoking, repeated fuse-blowing) do not attempt to make voltage checks. Switch the unit off and remove the AC plug until the short circuit has been located and the trouble corrected.

Parts found defective may be returned (postpaid) to us for replacement. If they are covered by the replacement warranty, new parts will be sent to you at no charge. All packages should be addressed to the Kit Adjustment Division.

## VOLTAGE CHART

All measurements made using a VTVM from chassis ground to point indicated, with a line voltage of 117V AC 60 cps, and volume control at minimum. All voltages shown are DC unless otherwise specified. Variations of  $\pm 15\%$  may be considered normal.

TUBE	PINS								
	1	2	3	4	5	6	7	8	9
V1	107	0	0.82	-11.3	-22.6	114	0	0.72	NC
V2	119	0	0.62	-22.6	-34	119	0	0.62	NC
V3	165	45	43	*	*	0.77	0	55	45
V4	NC	**	0.45	*	*	NC	260	NC	225
V5	NC	**	0.45	*	*	NC	260	NC	225
V6	107	0	0.82	0	-11.3	114	0	0.72	NC
V7	165	45	43	*	*	0.77	0	55	45
V8	NC	**	0.45	*	*	NC	260	NC	225
V9	NC	**	0.45	*	*	NC	260	NC	225

C37a 225 volts; C37b 215 volts; C38a 195 volts; C38b 180 volts.

\*Voltage between pins 4 and 5 should be 6.3V AC.

\*\*A reading of 0.45 volts at pin 3 of the EL86 tubes will be obtained with a voltage of approximately -19 at pin 2 of these tubes. Any large variation of the voltage at pin 2 is usually accompanied by a variation in the voltage at pin 3, and will indicate the need for readjustment of the bias and balance controls (see section in the manual under "Bias and Balance Adjustments").

## SERVICE FACILITIES

In the event that your checks do not enable you to correct the defect, you may, if you wish, take advantage of Lafayette's technical consultation service which is available to you without charge. The technical consultants are thoroughly familiar with every kit, but in order for them to help you to correctly diagnose the trouble it is important that you provide as much information as possible.

Details that you should include in any correspondence are:-

- a) Kit description and model number.
- b) Date purchased.
- c) A detailed description of the trouble encountered.
- d) Any checks that have been made and their results. (For example, did you check the wiring against the pictorials and instructions? Did you take voltage measurements?)

All correspondence should be addressed to:-

KIT ADJUSTMENT DIVISION  
LAFAYETTE RADIO ELECTRONICS CORP.  
111 JERICHO TURNPIKE SYOSSET, L. I., N. Y.

If you are not familiar enough with electronics to provide the information required for correct diagnosis, or in the event that you prefer to have the difficulty corrected for you, the unit may be returned to your nearest Lafayette branch store for repair or adjustment. The charge for this service is \$14.50, plus the cost of any parts which have been damaged during installation in the kit through improper soldering or handling. Kits which were not wired in accordance with our detailed instructions, or kits wired with acid solder or paste flux are not eligible for service and will be returned to you at your expense. Kits not completed which require extensive work will also be returned collect with a letter of explanation.

## DEALERS SERVICE

You may, if you wish, return a defective unit to your nearest Lafayette Associated store or authorized Lafayette Dealer for repair or adjustment. This will often be your fastest and most efficient method of obtaining service for your Lafayette kit. Charges for repair by a Dealer may be somewhat higher than those listed in this manual for factory service. However, the amount of increase will often be offset by the shipping charges you would have to pay if you returned the unit to Lafayette. The Lafayette warranty on parts will also be honored by Lafayette Dealers, regardless of whether the kit was purchased from Lafayette or through the dealer.

## SHIPPING INSTRUCTIONS

If the kit must be returned for service, tag the unit with your name, complete address and a brief description of the difficulties encountered.

Wrap the unit in heavy paper before placing into the carton which should be large enough to permit the use of at least three inches of shredded paper or excelsior between all sides of the unit and the carton. Mark the carton **FRAGILE** and clearly address it as follows:

TO:

KIT ADJUSTMENT DIVISION  
LAFAYETTE RADIO ELECTRONICS CORP.  
111 JERICHO TURNPIKE  
SYOSSET, L. I., N. Y.

Include your own name and address on the carton and ship by prepaid express. The unit will be returned to you express collect. Bear in mind that the carrier will disclaim responsibility for damage if, in his opinion, it was caused by improper packing.



Conceived and developed by Lafayette engineers, these kits offer every desirable feature that 41 years of experience can provide. Precise engineering and the use of only premium parts assure you of the best possible performance and the utmost reliability from the finished product. Whatever your need and budgetary level, there is a wide range of fine quality electronic equipment from which to choose. Each embodies the same fine engineering and handsome styling – each will provide a rewarding experience in kit construction.

*FOR THE FINEST IN ELECTRONIC KITS . . .*

**CHOOSE LAFAYETTE**

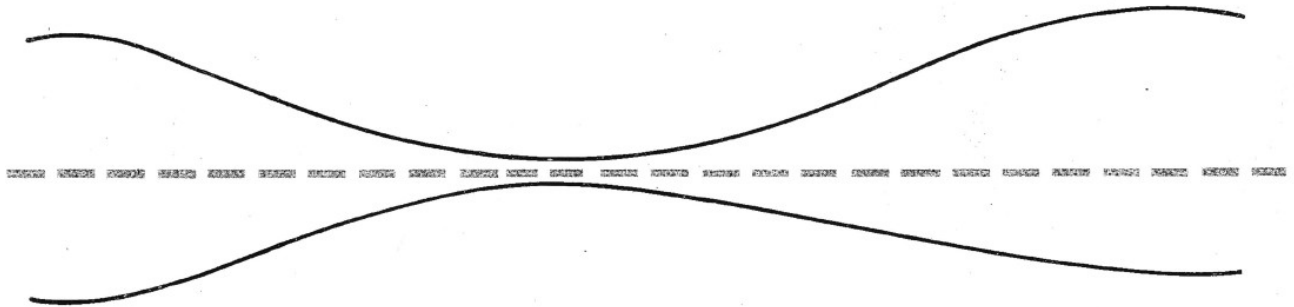

A PRODUCT OF

**LAFAYETTE ELECTRONICS  
MANUFACTURING CORP.**

165-08 LIBERTY AVENUE • JAMAICA 33, NEW YORK