

SERVICE MANUAL

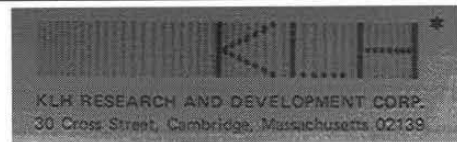

SFM-86

KLH MODEL FIFTY-TWO



SPECIFICATIONS

The following specifications have been derived in accordance with the Institute of High Fidelity (IHF) Standard of Measurement (IHF-A-20) and (IHF-T-100) in all cases where IHF standards exist. Furthermore, the amplifier power output specifications are stated in adherence to the proposed regulations of the Federal Trade Commission (FTC). The various figures, then, are not comparable with the loosely derived and vaguely stated specifications of many current components.

The specifications below are intended to provide complete information about the Model Fifty-Two—not thumbnail comparisons with other units of different manufacturers.

SEMICONDUCTOR COMPLEMENT

- 3 FETs (Field Effect Transistor)
- 36 silicon transistors
- 3 ICs (Integrated Circuit)
- 26 diodes
- 2 ceramic filters

ELECTRONIC

AMPLIFIER SECTION

- Continuous (RMS) power into 8Ω, both channels operating 30/30 watts
- Continuous (RMS) power into 4Ω, both channels operating 38/38 watts
- IHF music power into 8Ω, both channels operating 40/40 watts
- IHF music power into 4Ω, both channels operating 52/52 watts
- Harmonic distortion (THD) at full output 1.0%
- Harmonic distortion (THD) at 1 watt output 0.25%
- IM distortion at full output 1.0%
- IM distortion at 1 watt output 0.3%
- Power bandwidth into 8Ω 15-30,000 Hz
- Frequency response (1 watt) 15-22,500 Hz = 2 dB
- Damping factor at 8Ω greater than 20
- Stability unconditional
- S/N ratio (hum and noise below rated output, 20-20,000 Hz bandwidth, unweighted)
 - Phono inputs -63 dB (equivalent to 1.8 μV at input)
 - Auxiliary inputs -70 dB
 - Tape monitor inputs -70 dB
- Sensitivity for rated output
 - Phono inputs 3.5 mV
 - Auxiliary inputs 500 mV
 - Tape monitor inputs 500 mV
- input impedance
 - Phono inputs 47,000Ω
 - Auxiliary inputs 47,000Ω
 - Tape monitor inputs 47,000Ω
- Phono overload margin (60 mV) 25 dB
- Phono equalization RIAA

- Tape output level (for 30% FM or AM modulation or 3.5 mV phono input) 500 mV
- Tone control action
 - Bass = 10 dB at 100 Hz
 - Treble = 10 dB at 10,000 Hz
- High frequency filter
 - Crossover frequency 3500 Hz
 - Slope 6 dB/octave
- Loudness contour (10 o'clock position of volume control)
 - 50 Hz -13 dB
 - 100 Hz -10 dB
 - 1000 Hz 0 dB
 - 10,000 Hz -3 dB
 - 15,000 Hz -8 dB

FM TUNER SECTION

- Tuning range 87-109 MHz
- FM external antenna input impedance 300Ω balanced
- IF (Intermediate Frequency), nominal 10.7 MHz
- Usable sensitivity 2.0 μV
- S/N ratio 65 dB
- Full limiting (maximum S/N ratio) 10 μV or less
- Capture ratio 2.5 dB
- Image rejection 60 dB
- Alternate channel selectivity 46 dB
- IF rejection 70 dB
- Spurious response rejection 80 dB
- AM suppression 40 dB
- Suppression, 19 kHz 55 dB
- Suppression, 38 kHz 55 dB
- Mono harmonic distortion (THD) at 100% modulation 0.5%
- Stereo harmonic distortion (THD) at 100% modulation 0.8%
- Frequency response 20 Hz to 15 kHz = 2 dB
- Stereo separation at 1 kHz 35 dB
- Stereo separation at 10 kHz 25 dB
- Stereo-mono switching threshold (at 10%, 19 kHz modulation), nominal 4 μV
- Interstation noise suppression threshold 7 μV

AM TUNER SECTION

- Tuning range 540-1605 kHz
- Usable sensitivity 300 μV/meter
- S/N ratio, ultimate 50 dB
- IF 455 kHz
- AGC action greater than 50 dB RF signal change for 10 dB change in audio output
- Image rejection greater than 50 dB
- IF rejection greater than 40 dB
- Selectivity greater than 30 dB
- Spurious response rejection greater than 30 dB
- Harmonic distortion at 80% modulation 1.0%

POWER REQUIREMENTS

- Voltage, nominal 120 V

- Frequency (AC only) 50/60 Hz
- Maximum power consumption 180 watts

GENERAL

- All-silicon-solid-state
- Superheterodyne AM/FM tuner
- 4-gang FM FET front end
- Ultrastable local oscillator
- Separate 5-stage FM IF with 2 IC limiters and 1 ceramic filter
- Low-distortion ratio detector
- IC Multiplex stereo demodulator
- NO AFC required
- Automatic stereo/mono switching circuitry
- Switchable automatic interstation noise muting
- Internal adjustment for stereo/mono switching threshold
- Internal adjustment for interstation noise muting threshold
- AM/FM signal strength meter
- FM center-of-channel tuning meter
- Built-in FM linecord antenna
- Input for balanced external 300Ω FM antenna
- Separate 2-stage AM IF with 1 ceramic filter
- High-sensitivity, ferrite-rod, pivoting AM antenna
- Input for external AM antenna
- Flywheel-weighted tuning knob
- Tape recording and monitoring facilities
- Headphones output jack
- High-frequency noise filter
- Switchable loudness contour with low- and high-frequency compensation
- Main and remote loudspeaker switching facilities
- FET tone control circuitry
- Separate bass and treble tone controls
- Individual control of bass and treble for each channel
- Friction-clutch tone control design
- Quasi-complementary-symmetry output stages
- Short-circuit-proof output stage design
- Fuse protection for both AC input and loudspeaker outputs
- AC convenience outlet
- Separate chassis ground terminal
- Indirectly illuminated blackout dial panel
- Translucent contrasting dial pointer
- Lighted source indicator panel
- RF-interference-shielded walnut grain enclosure
- MECHANICAL
- Dimensions, including knobs and fully extended AM antenna 5¼"H x 18"W x 18½"D
- Dimensions, excluding knobs but including extended AM antenna 5¼"H x 18"W x 17½"D
- Dimensions, excluding both knobs and AM antenna 5¼"H x 18"W x 11½"D
- Weight, unpacked, nominal 22½ lb.
- Weight, shipping, nominal 25½ lb.

Top Chassis

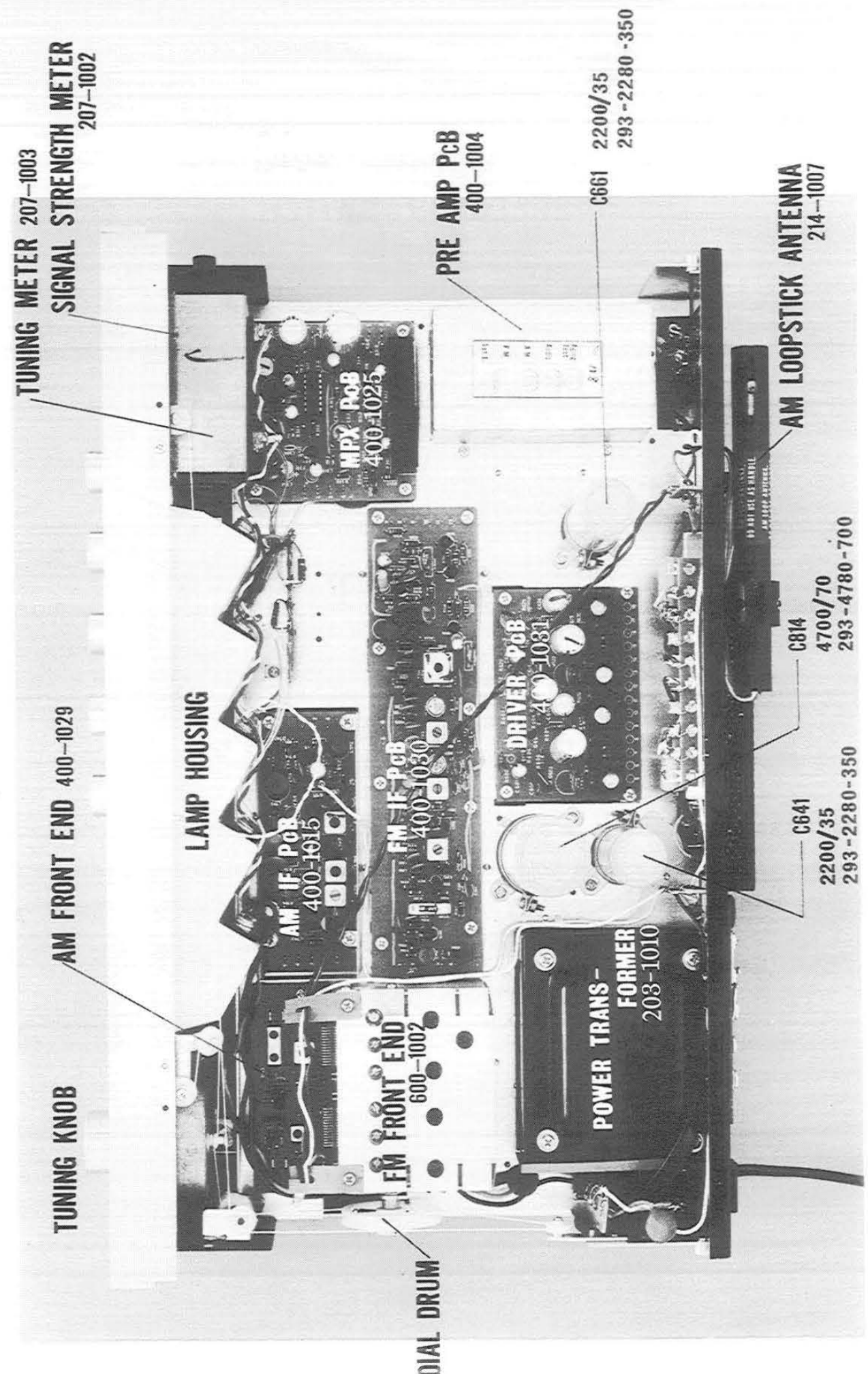

Bottom Chassis

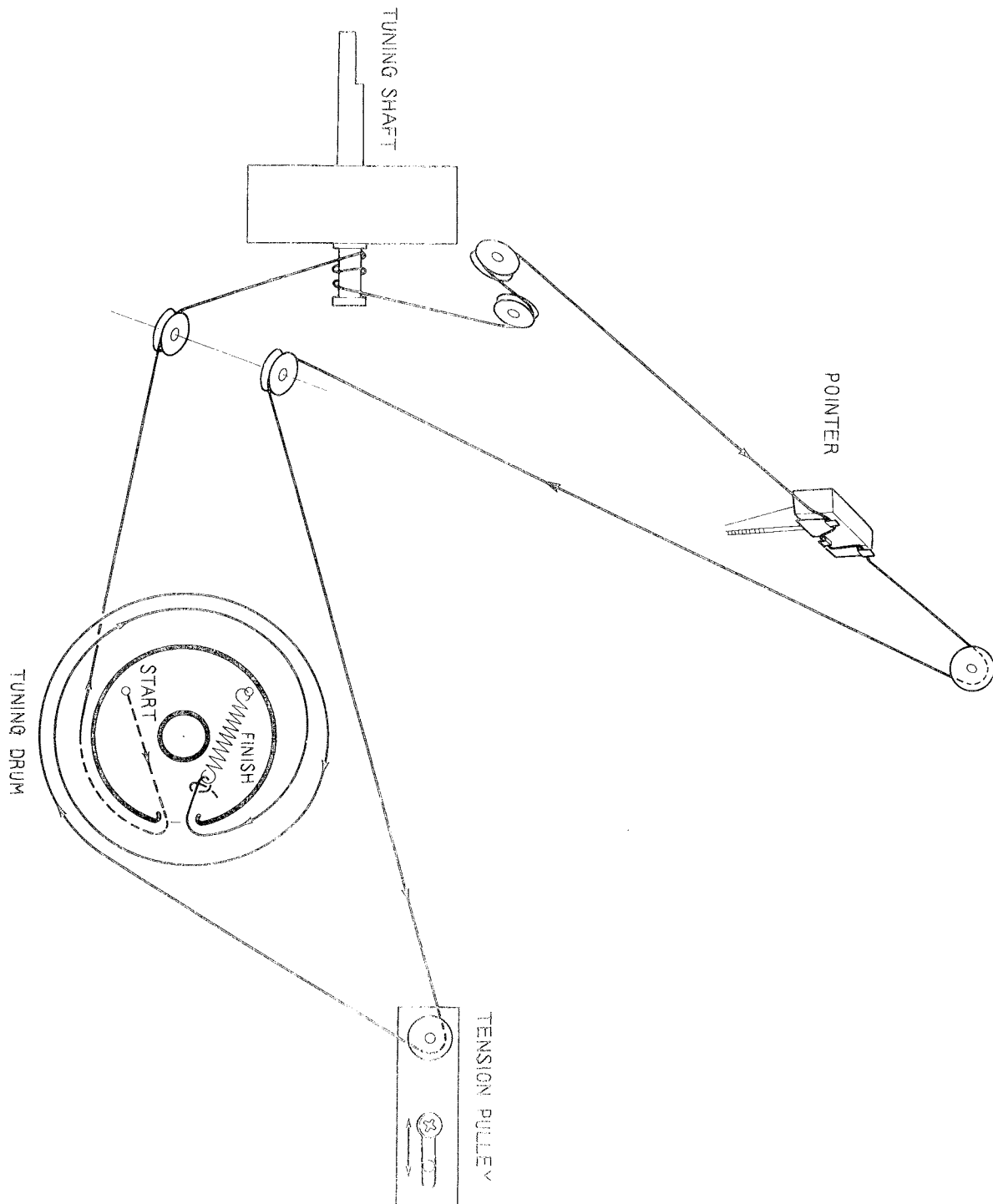
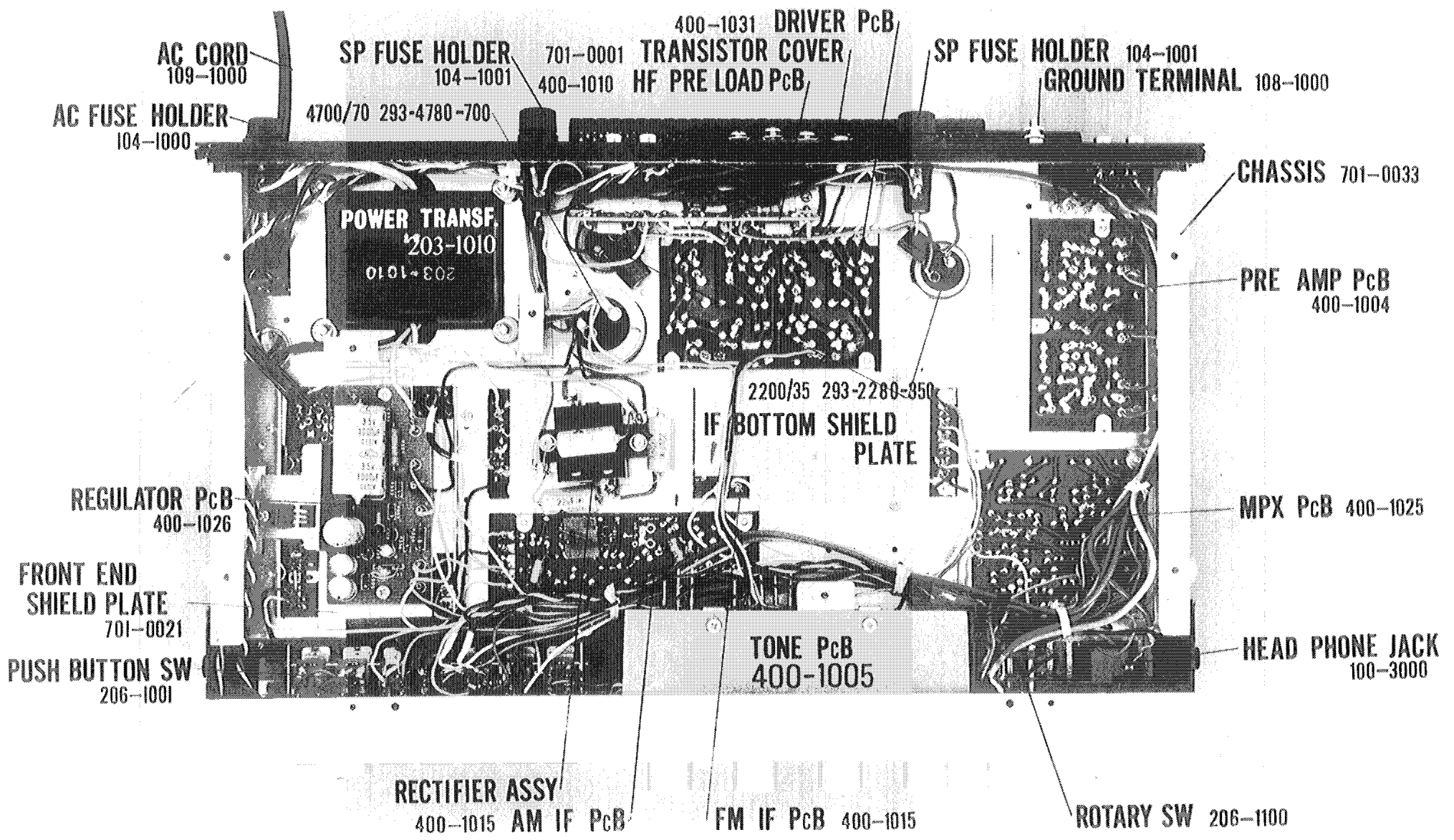

Dial Stringing

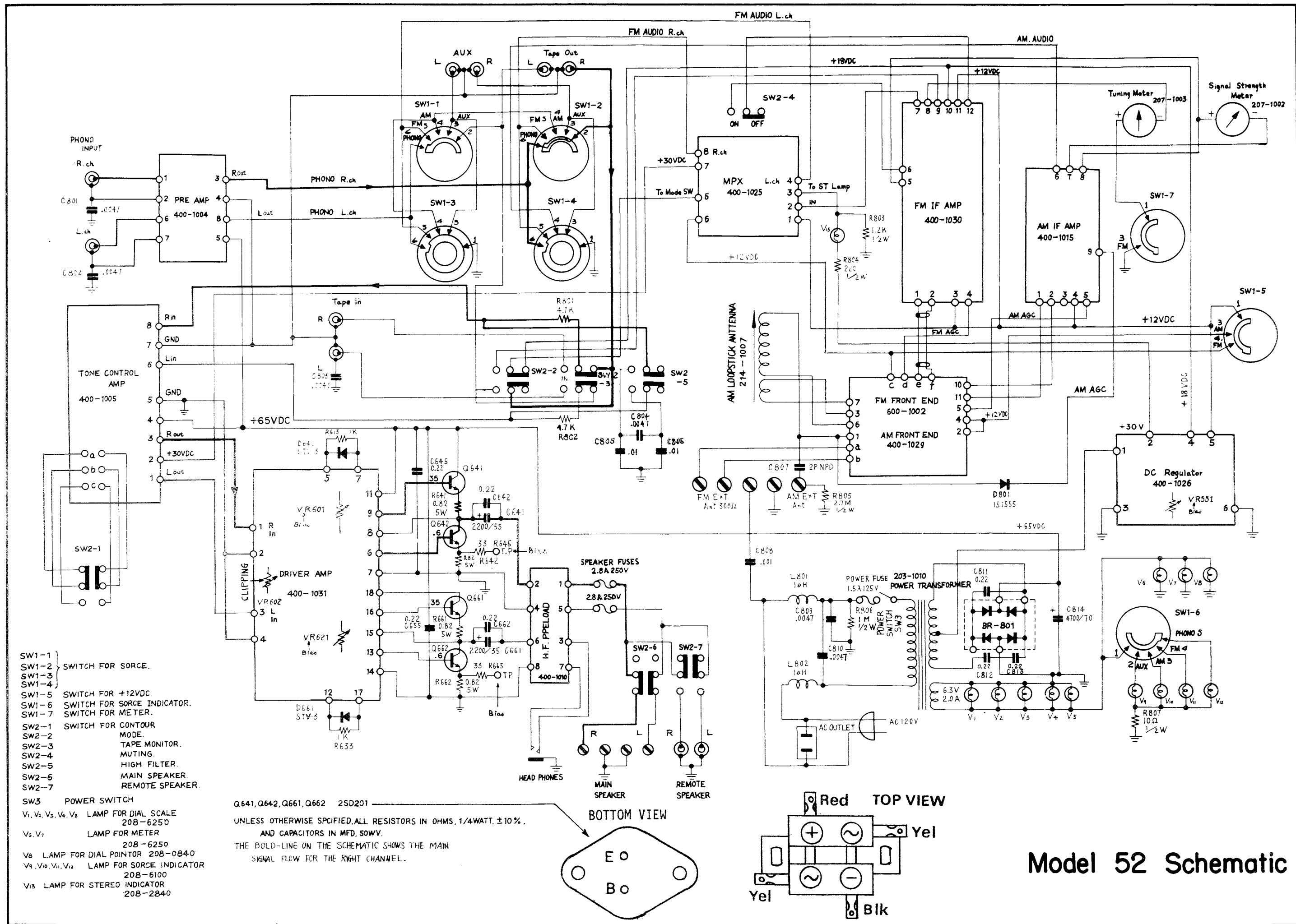

- SW1-1 } SWITCH FOR SOURCE.
- SW1-2 }
- SW1-3 }
- SW1-4 }
- SW1-5 SWITCH FOR +12VDC.
- SW1-6 SWITCH FOR SOURCE INDICATOR.
- SW1-7 SWITCH FOR METER.
- SW2-1 SWITCH FOR CONTOUR
- SW2-2 MODE.
- SW2-3 TAPE MONITOR.
- SW2-4 MUTING.
- SW2-5 HIGH FILTER.
- SW2-6 MAIN SPEAKER.
- SW2-7 REMOTE SPEAKER.
- SW3 POWER SWITCH
- V1, V2, V3, V4, V5 LAMP FOR DIAL SCALE 208-6250
- V6, V7 LAMP FOR METER 208-6250
- V8 LAMP FOR DIAL POINTOR 208-0840
- V9, V10, V11, V12 LAMP FOR SOURCE INDICATOR 208-6100
- V13 LAMP FOR STEREO INDICATOR 208-2840

Q641, Q642, Q661, Q662 2SD201
 UNLESS OTHERWISE SPECIFIED, ALL RESISTORS IN OHMS, 1/4WATT, ±10%
 AND CAPACITORS IN MFD, 50WV.
 THE BOLD-LINE ON THE SCHEMATIC SHOWS THE MAIN SIGNAL FLOW FOR THE RIGHT CHANNEL.

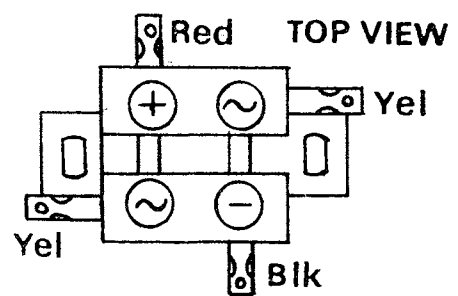
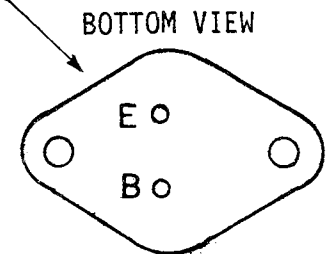

Model 52 Schematic

SELECTOR SWITCH SW -1

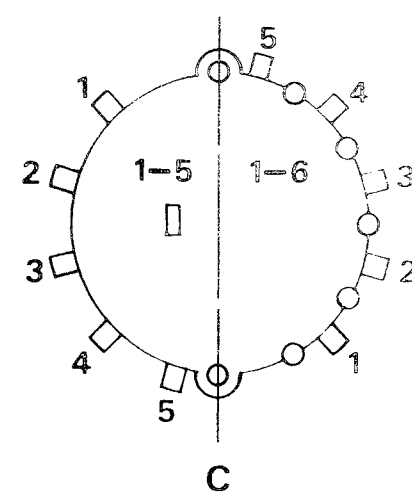
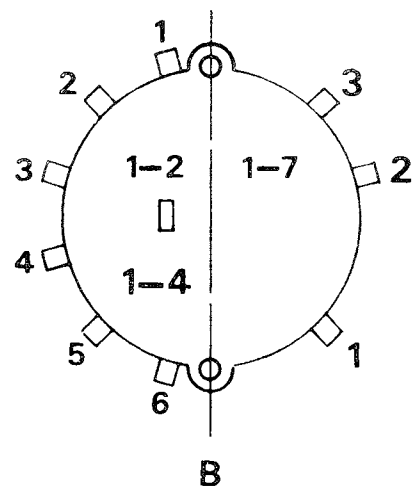
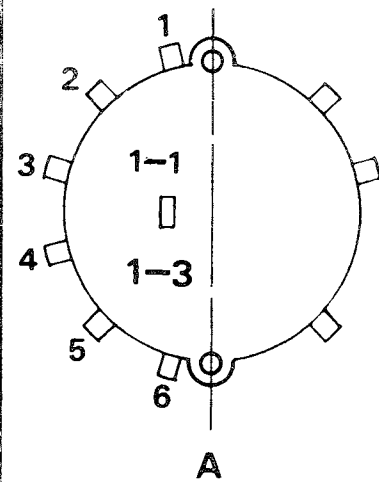
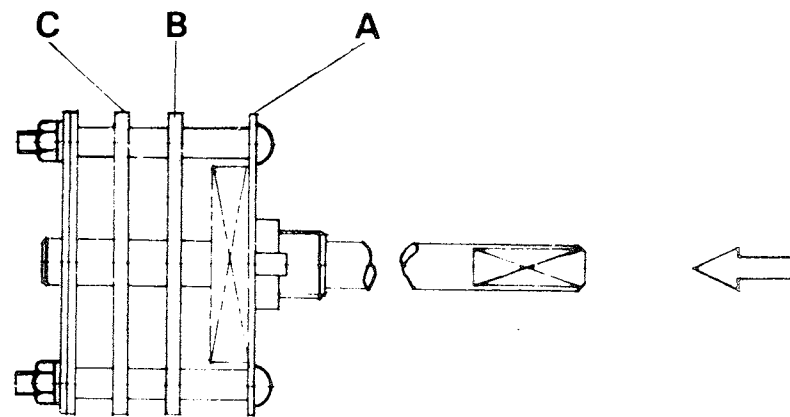

2N5457



MPS U06

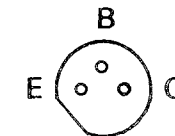

SE1001



2SC 1000
2SC 380(A)
2SC 372
2SC 373
2SC 732
2SC 381

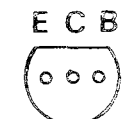

2SC640

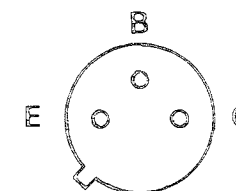

2SC485
2SA485

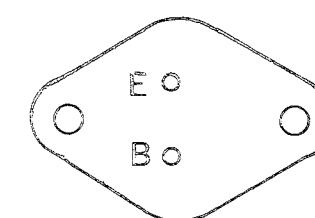

2SD201



2SD313



2SK19

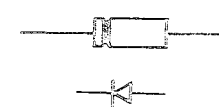

1N60, 1N60P
1S1555

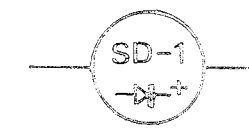

SD-1YS



STV-3

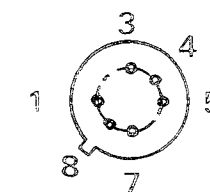

μ A 703

TOP VIEW

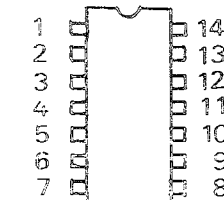

μ A 767

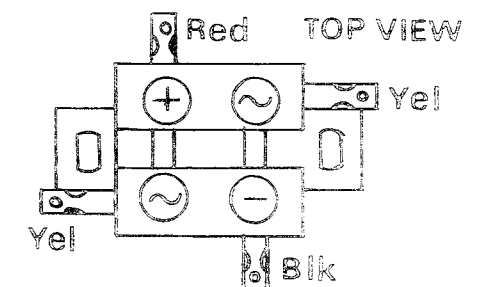

Rectifier

AUDIO ELECTRONICS

BIAS and CLIPPING ADJUSTMENT

Bias alignment

Connect VAO to T.P. on output stage (the end point of R645 and R665) and adjust VR601 and VR 621 on Driver board to 20 - 25mv. Move VAO to pin 4 on regulator board and align VR551 to get 18 volts dc.

Symmetrical clip adjustment

Apply input signal (1KHz) to Aux input and observe the output wave form on scope. Adjust output until clipping just barely occurs. Align VR602 on Driver board for equal clipping of both halves of the sine wave.

Set controls as follows:

Function selector: AUX
 Tone : Flat
 Loudness : Max
 Balance : Midpoint
 Push buttons : All "OUT" position

Connect the main speaker outputs to the 8 ohm 50 watt noninductive load resistors.

DC Regulator

SCHEMATIC

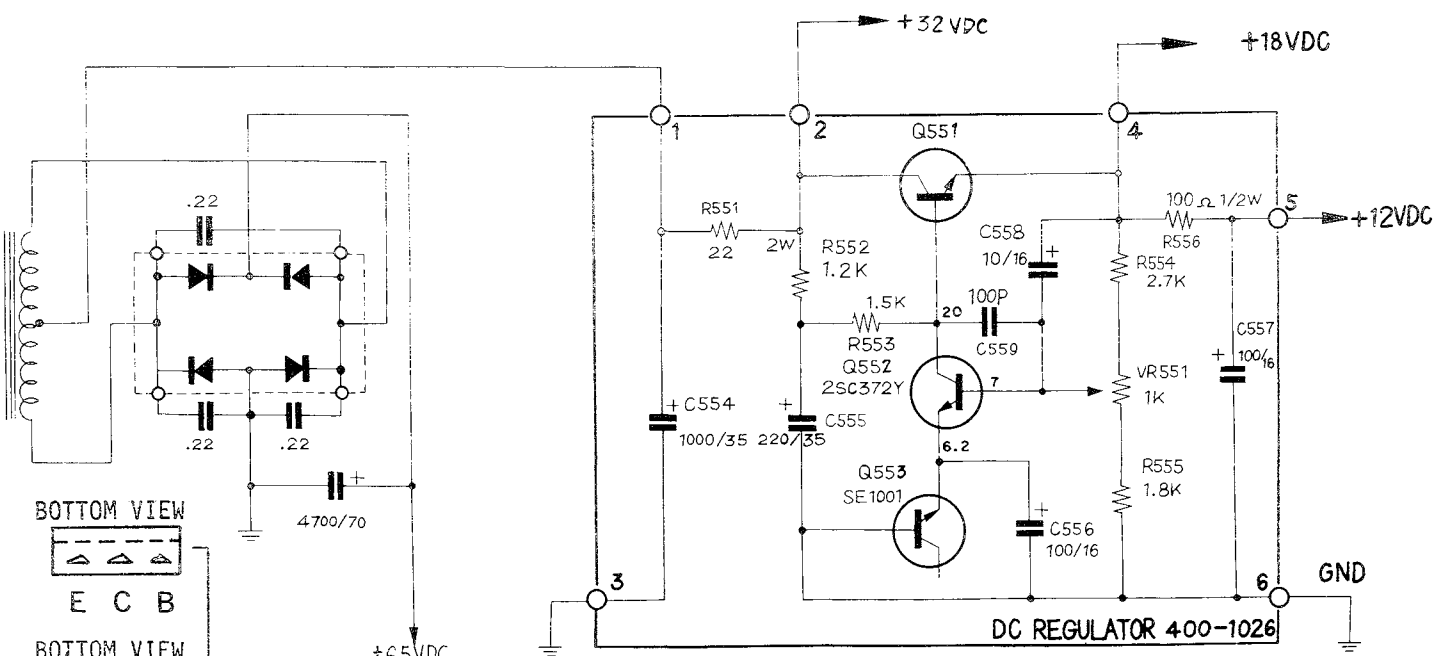

BOTTOM VIEW

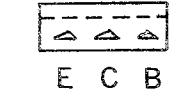

BOTTOM VIEW

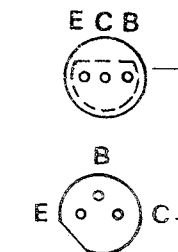

Q551 2SD313D
 Q552 2SC372Y
 Q553 SE1001

UNLESS OTHERWISE SPECIFIED ALL RESISTANCE IN OHM, 1/4WATT, ±10%,
 AND CAPACITOR IN MFD.

COMPONENT SIDE

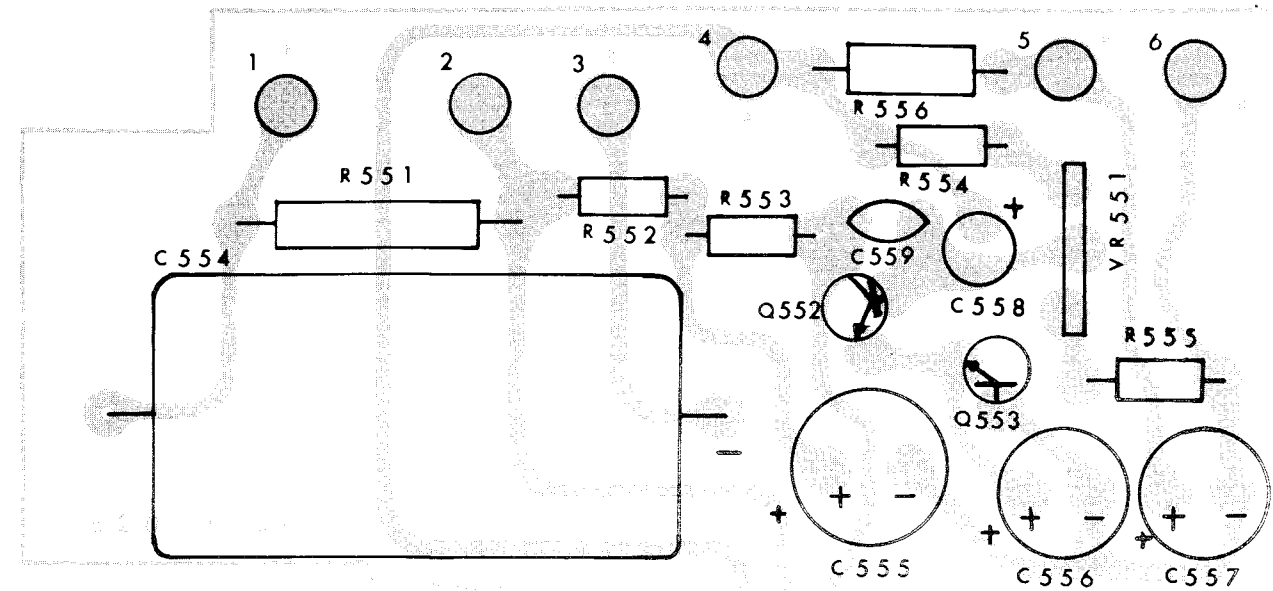

BOTTOM VIEW

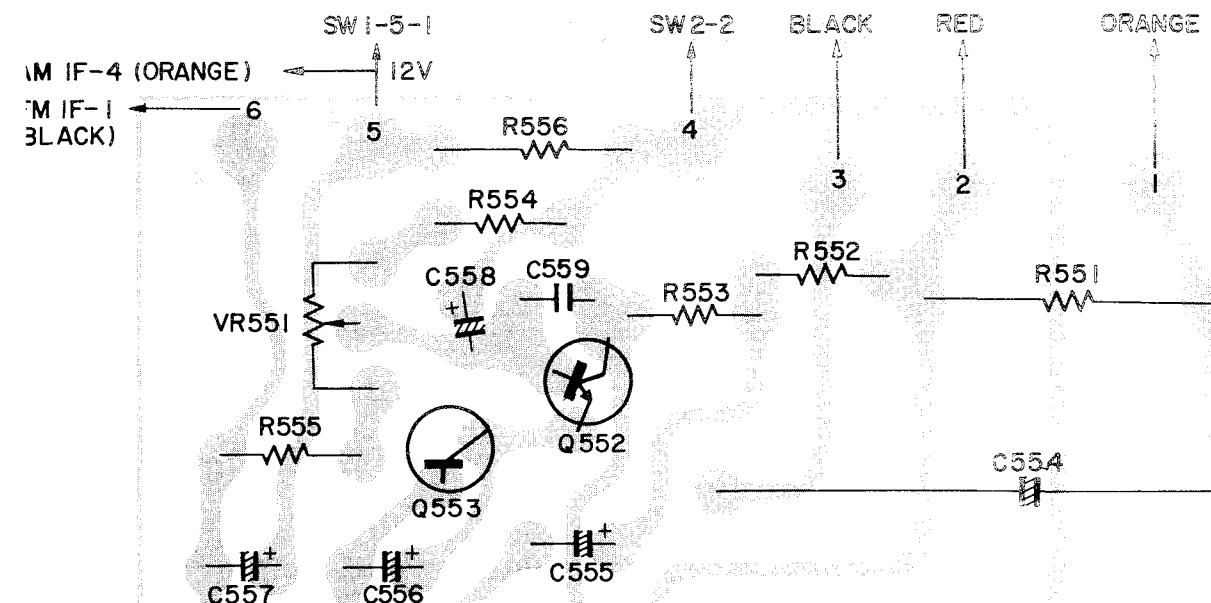

Driver, Output and High Frequency Preload

AC VOLTAGES
DRIVER & OUTPUT

COMPONENT	E	B	C
Q601, Q621	82mV	81mV	1mV
Q602, Q622	0	1mV	3.5V
Q603, Q623	3.4V	3.4V	*125mV
Q604, Q624	3.3V	3.5V	4V
Q641, Q661	3.2V	3.4V	*125mV
Q642, Q662	*155mV	4V	3V

*NONSINUSOIDAL WAVEFORM

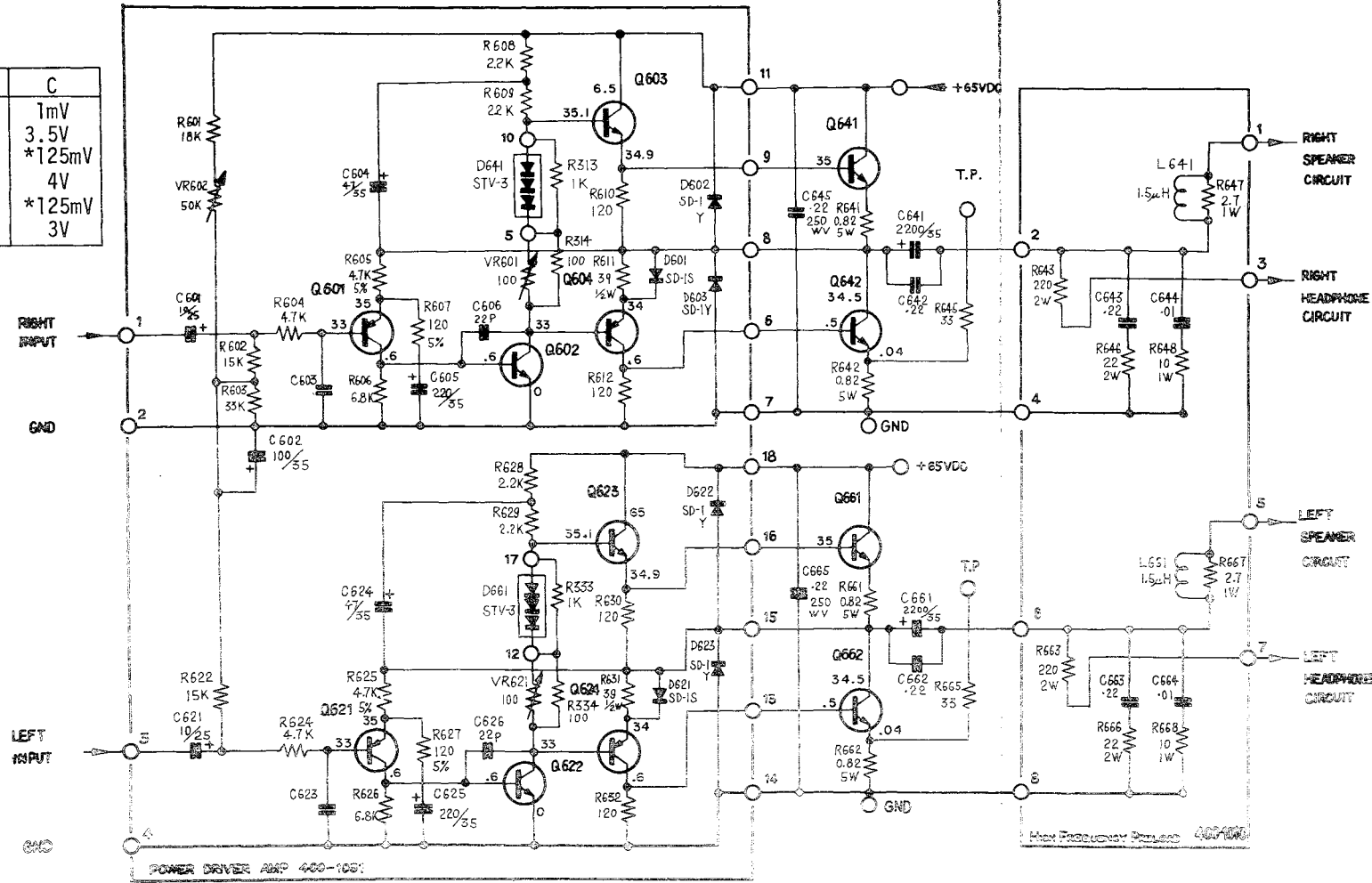

TOP VIEW

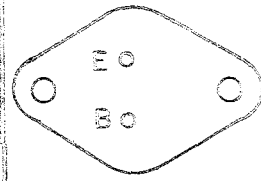

NOTE:
Q601, Q621 - 2SA640
Q602, Q622 - MPS-1006, Q603, Q623 2SC4056B1
Q604, Q624 - 2SA405(BL)
Q641, Q642, Q661, Q662 - 2SD201
UNLESS OTHERWISE SPECIFIED, ALL RESISTORS IN OHMS, ±10%, 1/40WATT,
CAPACITANCE IN MFD.

Driver Amp.

COMPONENT SIDE

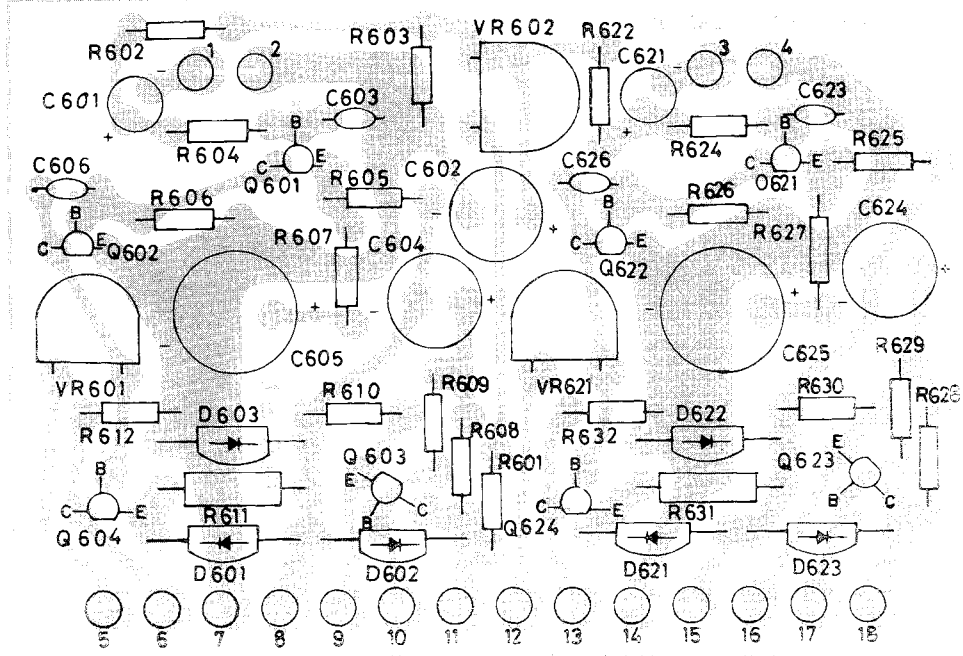

BOTTOM VIEW

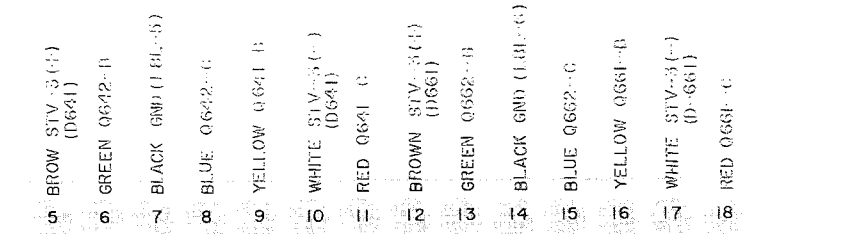

HF Preload

COMPONENT SIDE

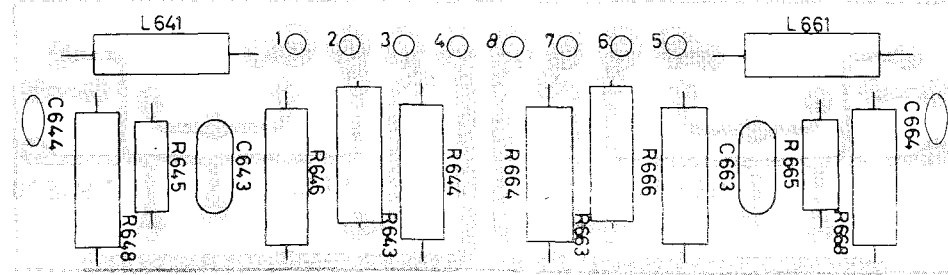

BOTTOM VIEW

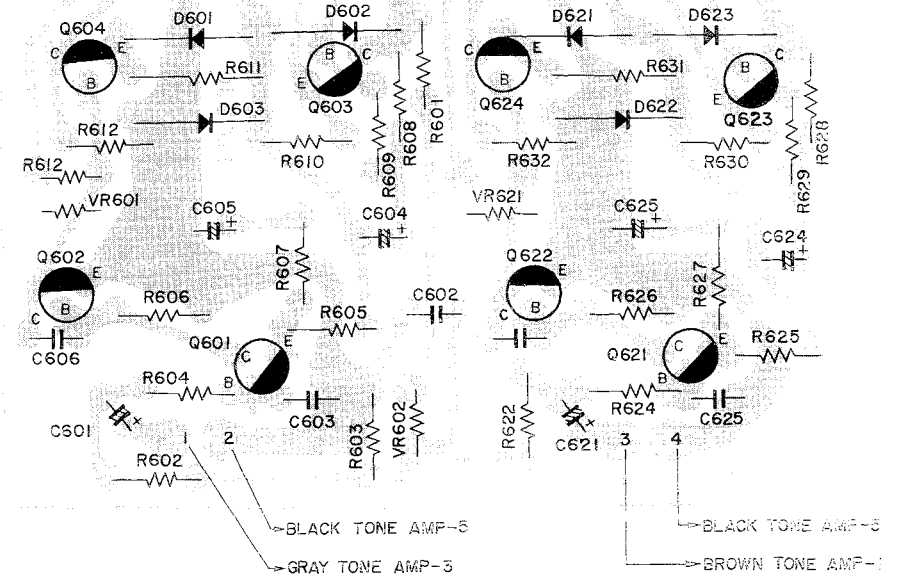
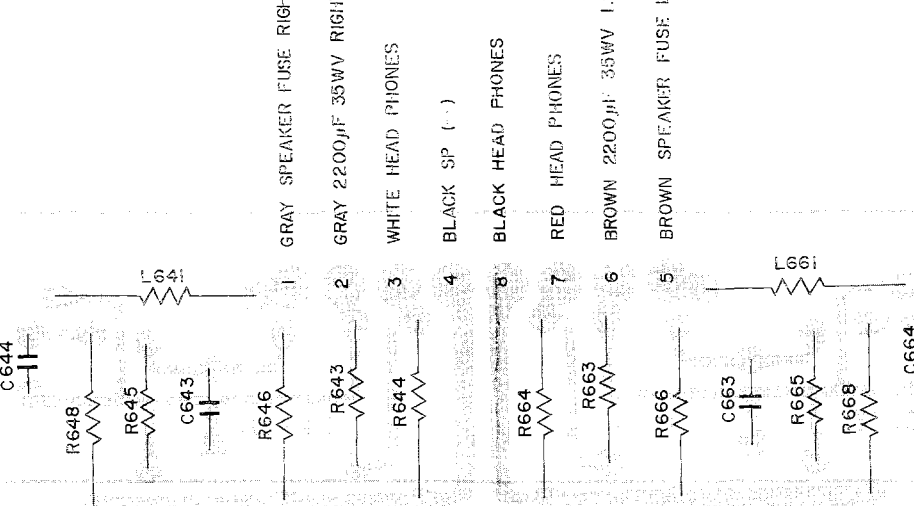

Preamplifier

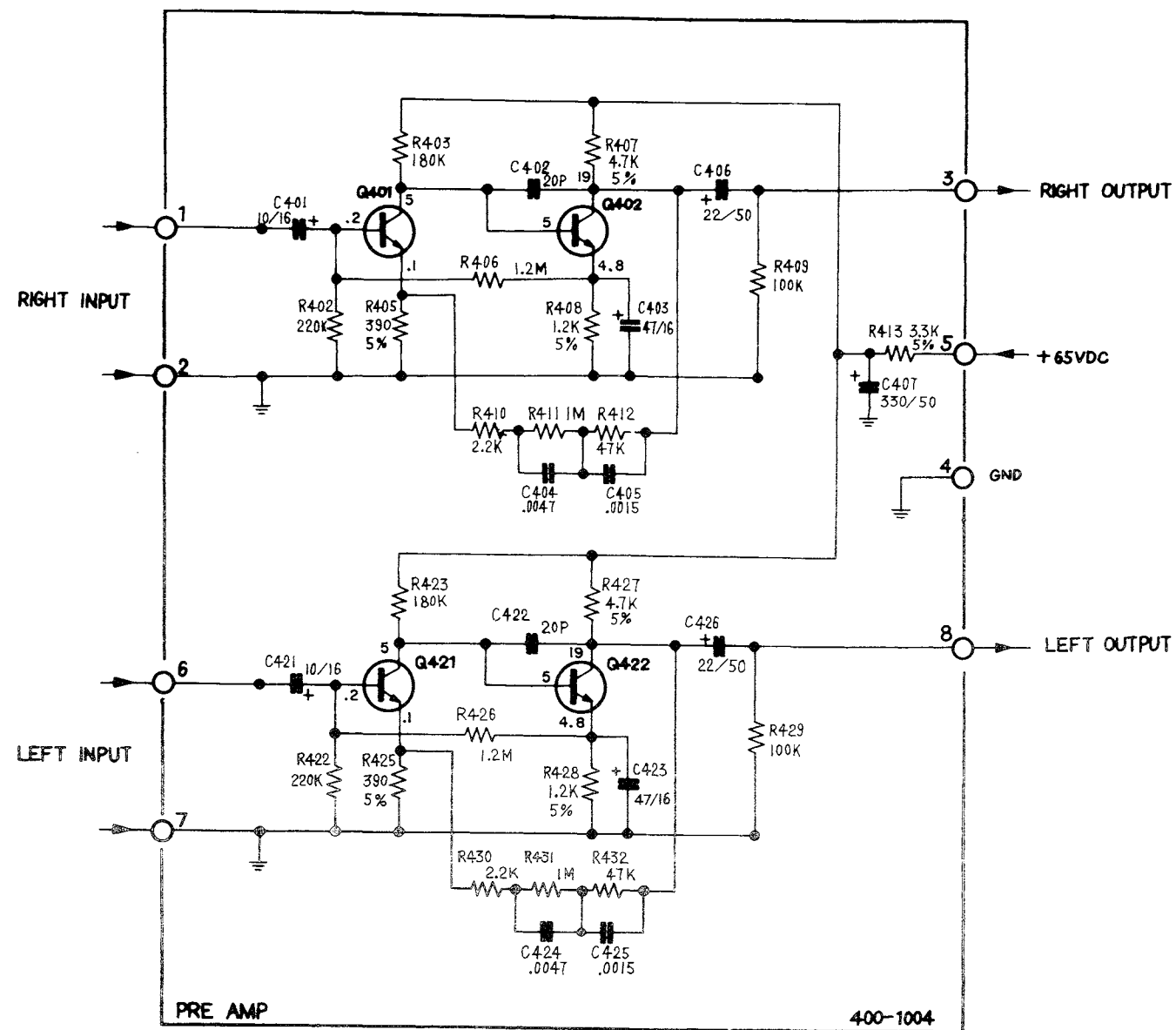

BOTTOM VIEW

NOTE:
 Q401, Q402, Q421, Q422 2SC1000
 UNLESS OTHERWISE SPECIFIED, ALL RESISTANCE IN OHM, $\pm 10\%$, 1/4WATT,
 CAPACITANCE IN MFD.

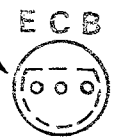

SIGNAL VOLTAGE
 (Volts RMS unless otherwise specified)

COMPONENT	E	B	C
Q401	3mV	3mV	1.4mV
Q402	.7	1.4mV	450mV

Insert 3.0 millivolts into the Phono Input at 1000 Hz using a generator with a floating ground. Set the volume control CCW.

COMPONENT SIDE

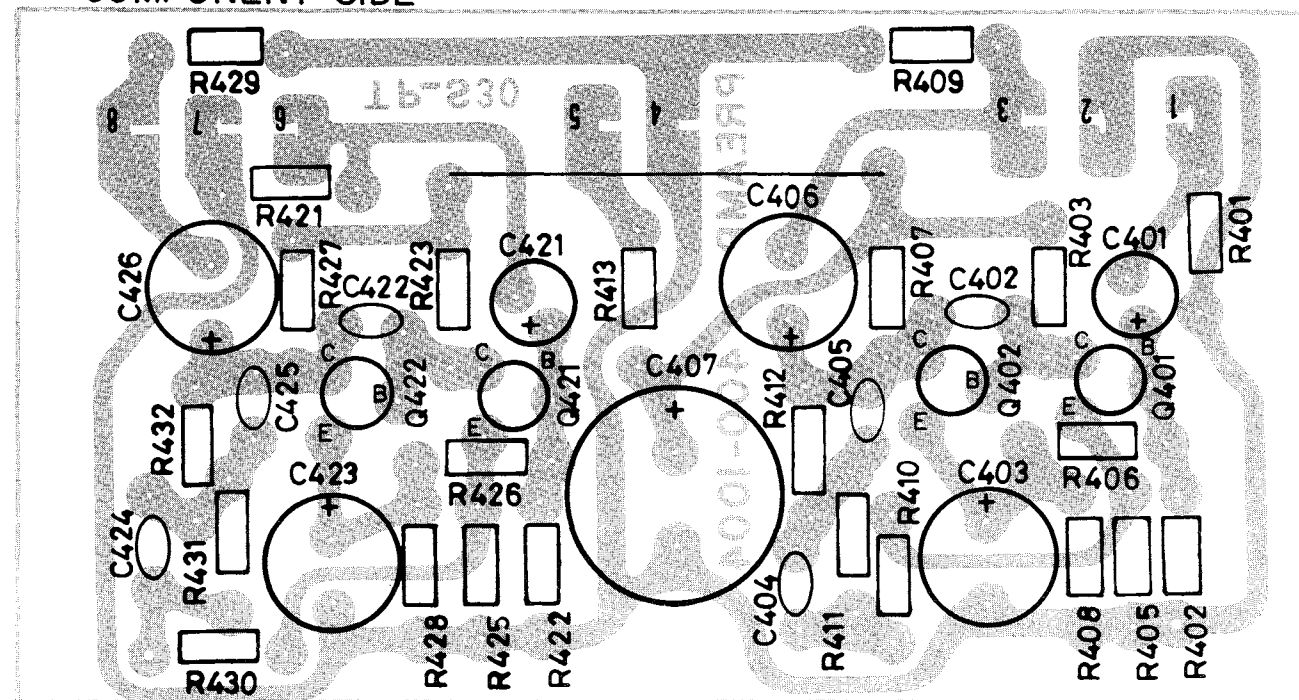

BOTTOM VIEW

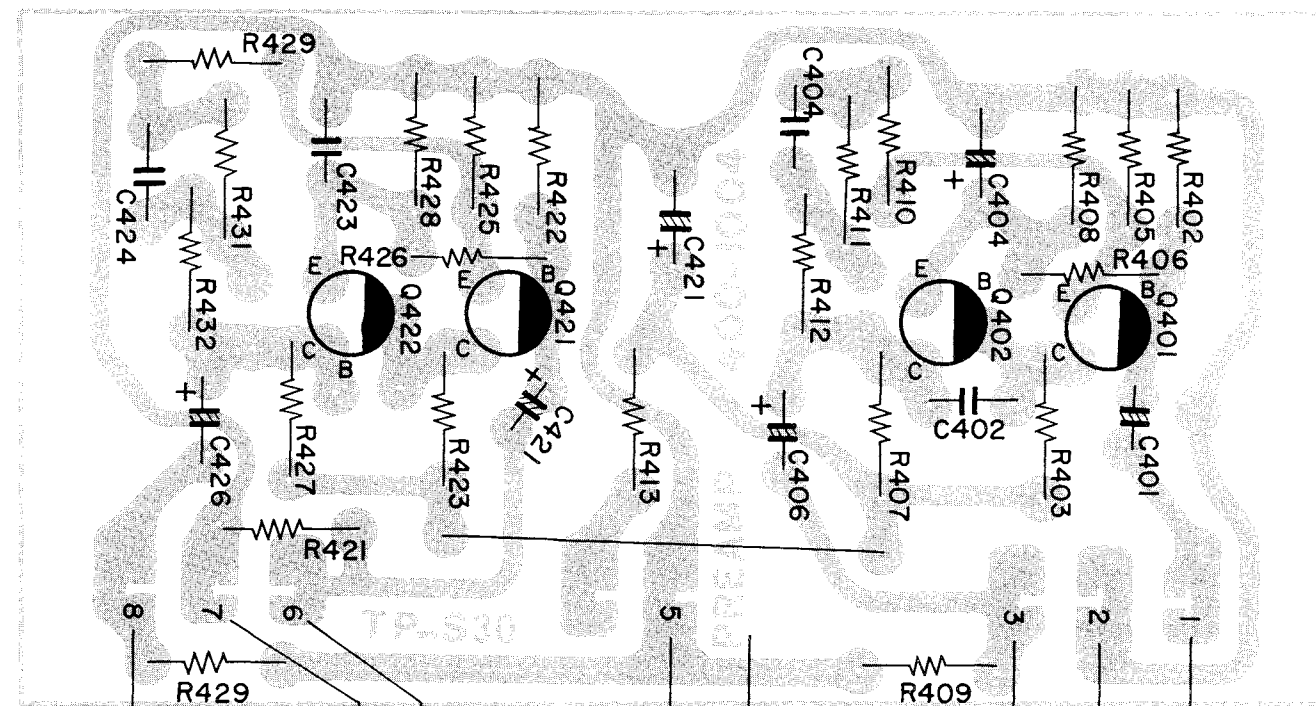

- 1 GRAY PHONE JACK IN RIGHT
- 2 BLACK PHONE JACK IN RIGHT
- 3 GRAY SW1-2 SW1-4
- 4 RED TONE PCB PIN 4
- 5 BROWN PHONE JACK IN LEFT
- 6 BLACK PHONE JACK IN LEFT
- 7 BROWN SW1-1 SW1-3
- 8 BROWN SW1-1 SW1-3

FM-AM ELECTRONICS

AM Front End

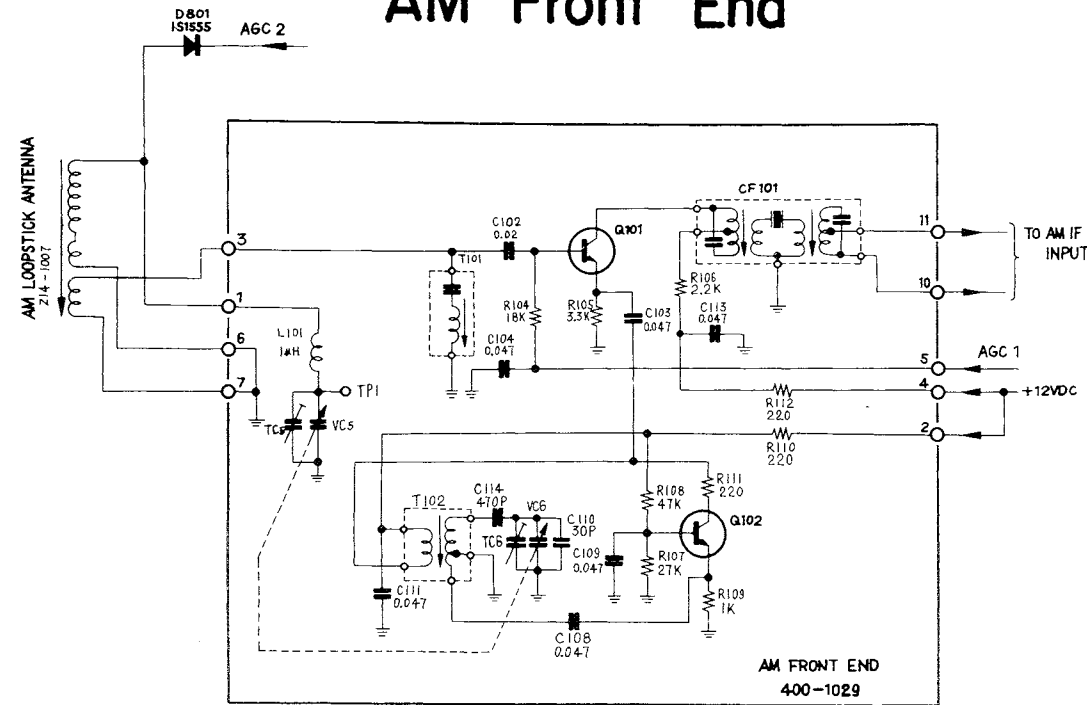

Q101, Q102 2SC380A(0)

UNLESS OTHERWISE SPECIFIED ALL RESISTOR IN OHM, 1/4WATT, ±10%,
AND CAPACITOR IN MFD.

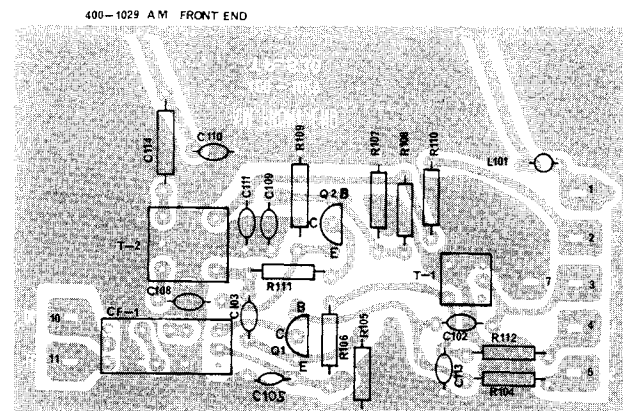

COMPONENT
SIDE

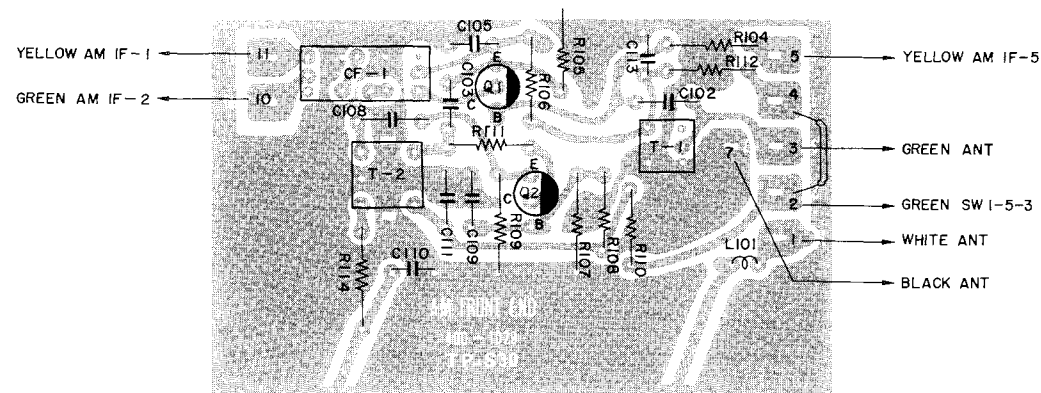

BOTTOM
VIEW

AM-IF

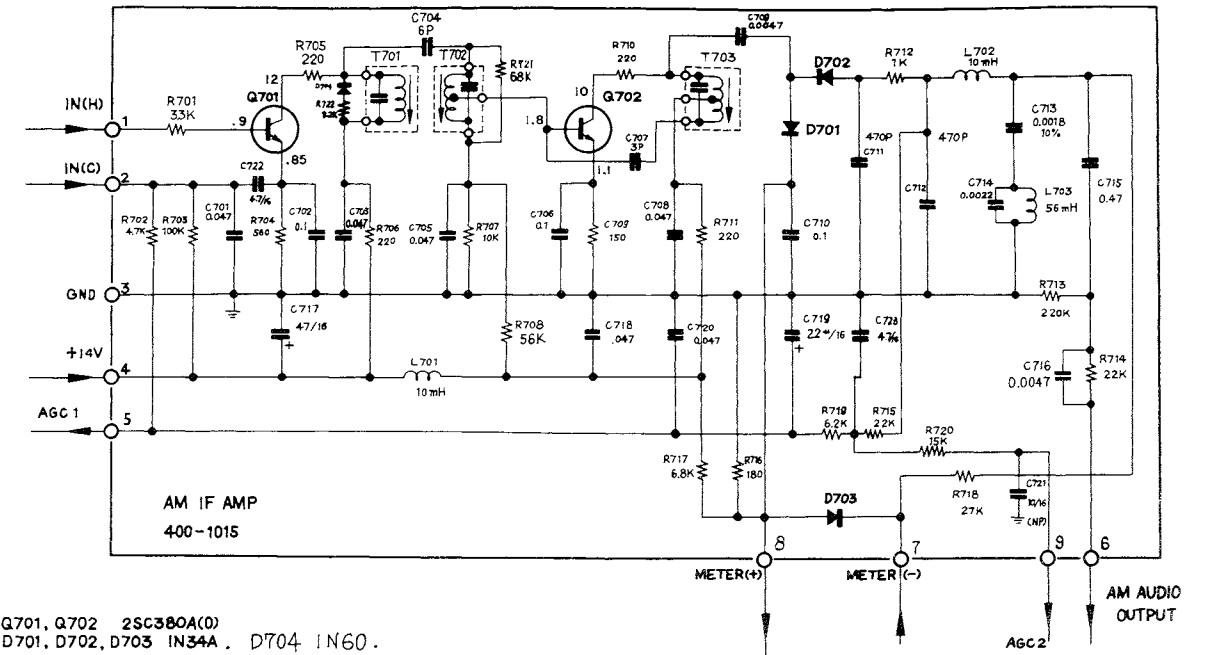

Q701, Q702 2SC380A(0)
D701, D702, D703 IN34A, D704 IN60.

UNLESS OTHERWISE SPECIFIED, ALL RESISTOR IN OHM, 1/4WATT, ±10%,
AND CAPACITOR IN MFD.

COMPONENT SIDE

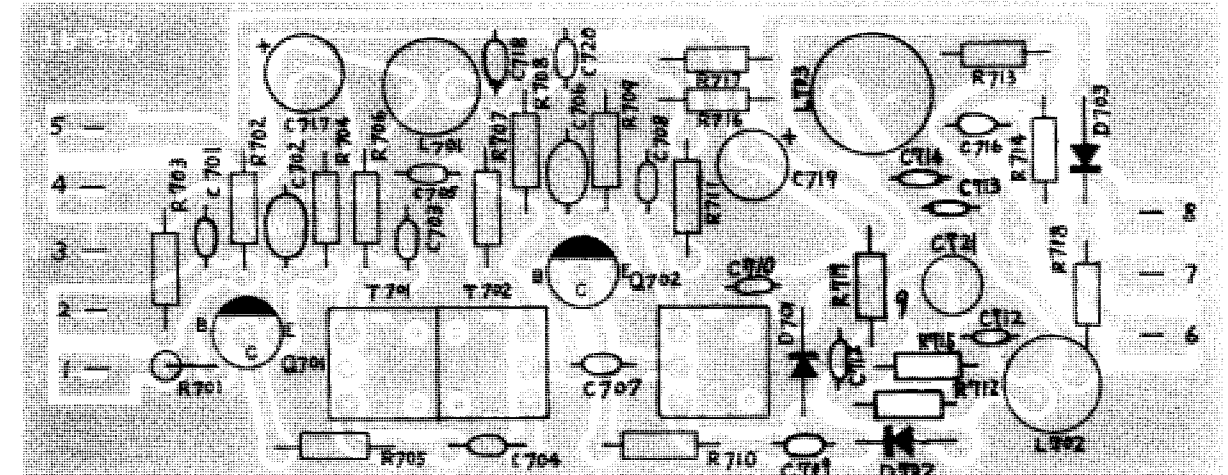

BOTTOM VIEW

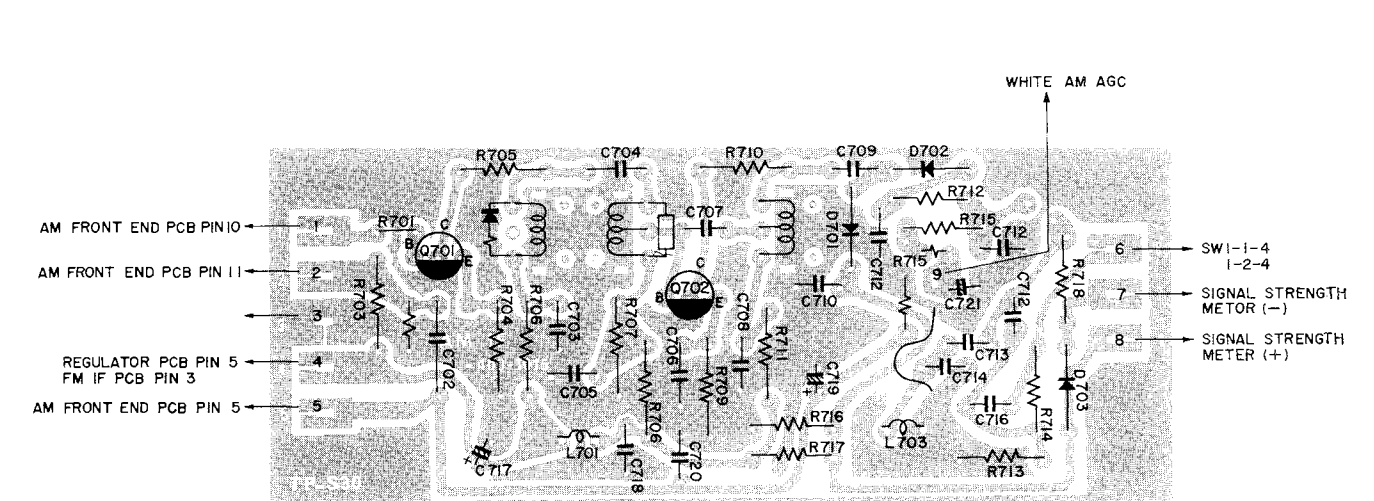

AM IF ALIGNMENT

Step	Tuner switches & Dial setting	Coupling	Generator freq. and mod.	Generator RF output $\mu\text{V/m}$	Monitor	Adjustments & Indications
1-A 455KHz trap	Point of no local interference.	-----	-----	-----	-----	Before aligning the IF stage entirely tune out 455KHz trap T101. After the next step, tune T101 to the mid bandpass of IF.
1-B IF Alignment	Point of no local interference.	Sweep generator loosely coupled to white lead from loopstick.	455KHz	Use lowest RF level, avoiding AGC action.	Scope to "Tape Out"	Adjust CF101 on AM RF board and &701,702,7.3 on IF strip to get proper flat-top bandpass response.
2-A Calibration & tracking at low end.	Local station around 600KHz.	-----	-----	As low as possible.	"	Adjust T102 on RF board and loopstick for maximum output. If necessary, turn the unit to get weak output to recognize the peak.
2-B Calibration & tracking at high end.	Local station around 1400KHz.	-----	-----	"	"	Adjust TC6 and 5 on variable cap for maximum output. If necessary, turn the unit to get weak output.

MPX ALIGNMENT

Step	Tuner switches & Dial setting	Coupling	Generator freq. and mod.	Generator RF output $\mu\text{V/m}$	Monitor	Adjustments and Indications
1-A Composite signal alignment	Point of no local interference. Stereo mode.	Antenna terminal.	Same as FM dial, 400Hz, 75Hz dev. stereo mode 8% pilot level.	1K $\mu\text{V/m}$	Scope at TP1, must use high freq. probe.	Adjust T301 for straight baseline of composite signal.
B. 19KHz	"	"	"	"	Move scope to TP2.	Peak T303 and 304 for 19KHz.
C. 38KHz	"	"	"	"	Move scope to TP-3.	Peak T305 for 38KHz.
D. Separation adjustment.	"	"	"	"	Scope to "Tape Out".	Align T305 and 301 for maximum separation and lowest THD. If necessary, touch up T303 and 304, but not more than $\frac{1}{4}$ turns.
2. Stereo Threshold	"	"	"	10 $\mu\text{V/m}$	"	Adjust VR202 to allow unit to switch into stereo.

COMPONENT SIDE

Multiplex

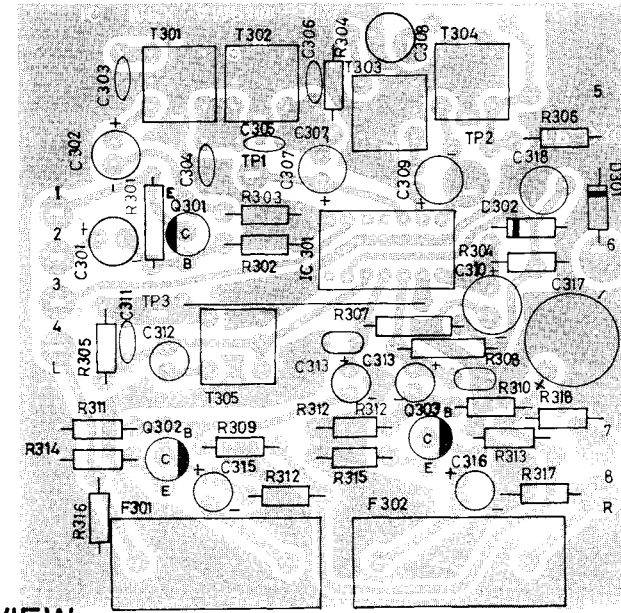
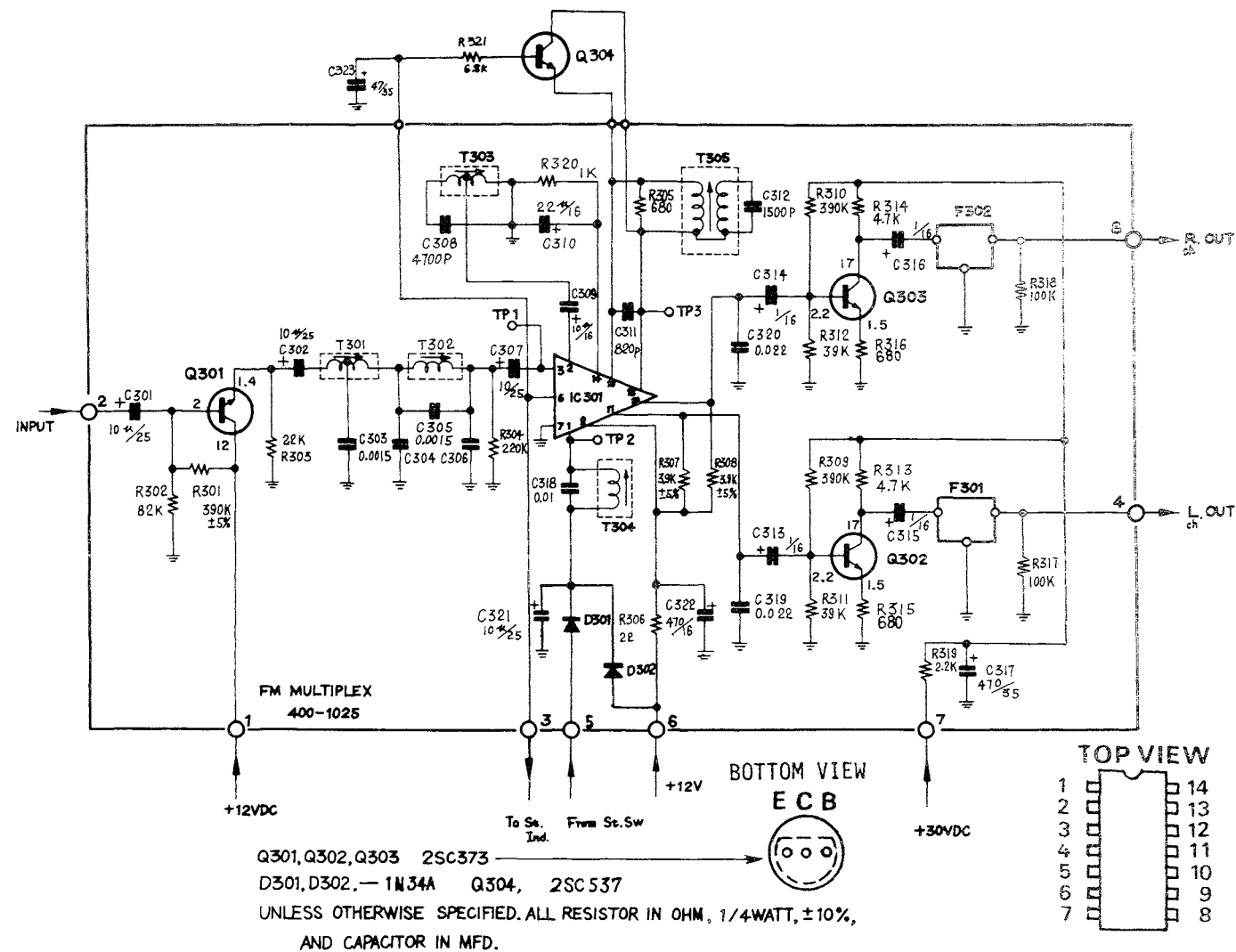

BOTTOM VIEW

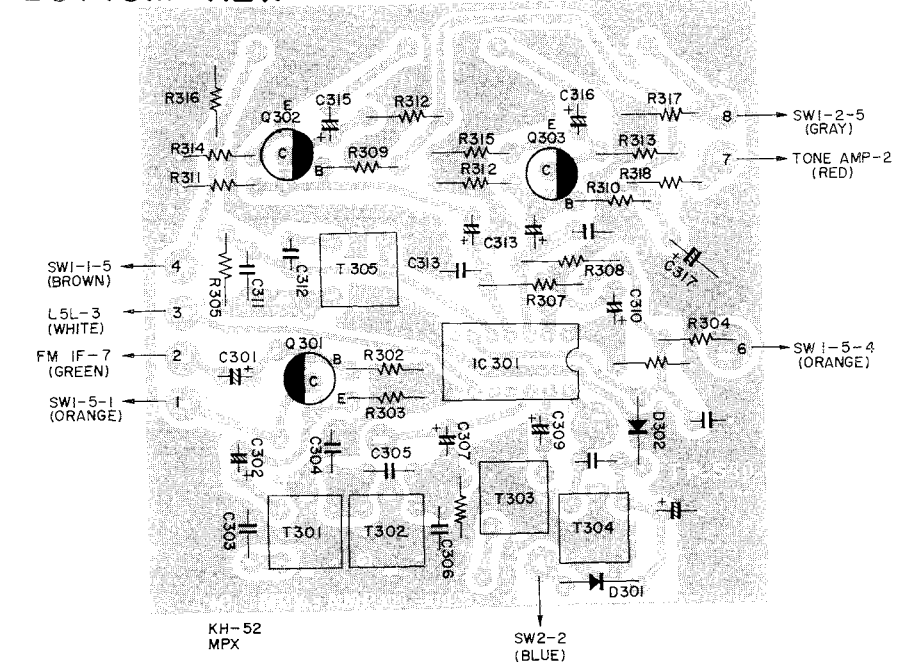

FM IF Amp.

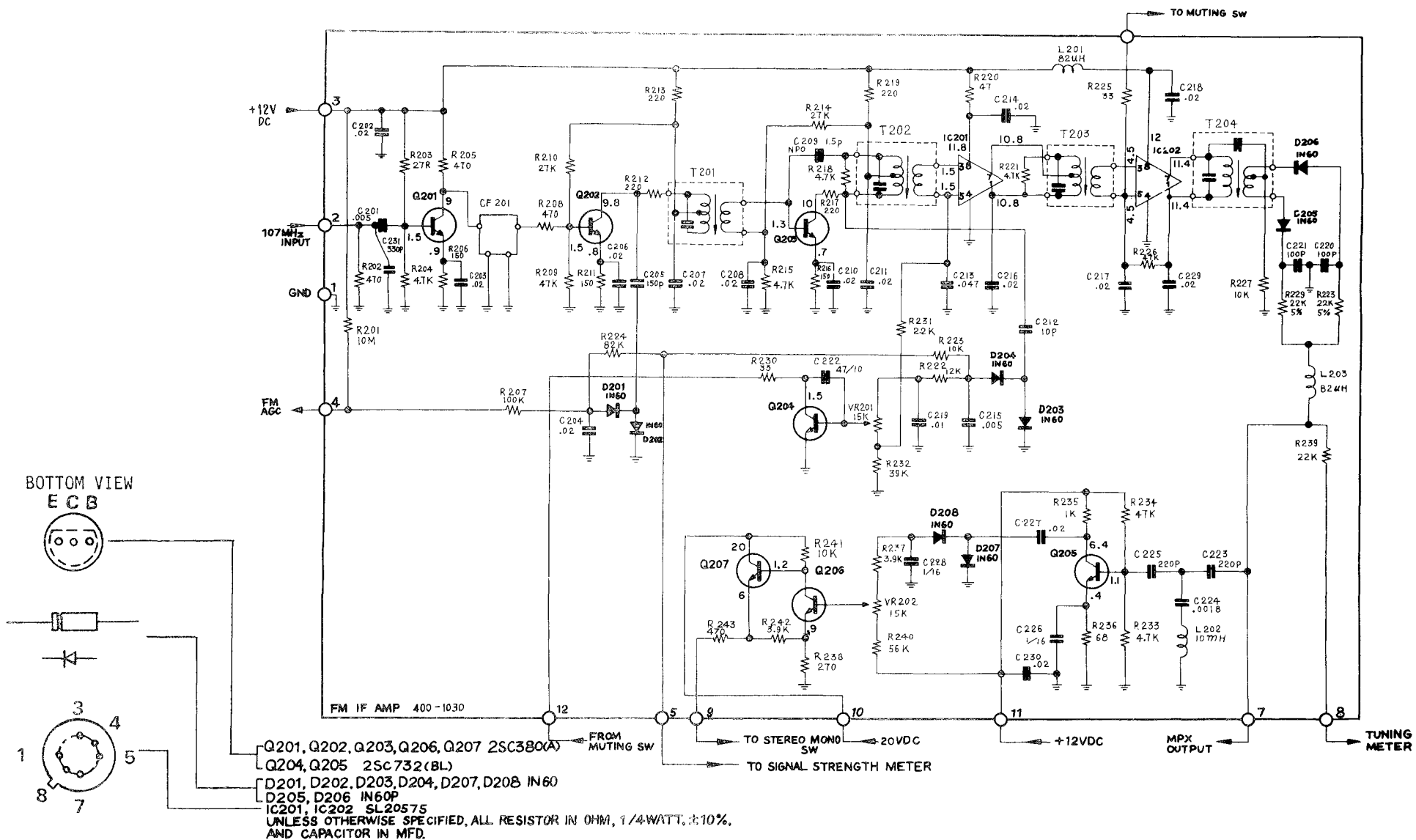

FM-IF and DETECTOR ALIGNMENT

Step	Tuner switches & Dial setting	Coupling	Generator freq. and mod.	Generator RF output $\mu\text{v}/\text{m}$	Monitor	Adjustments and Indications
1-A IF alignment	FM interstation noise. Point of no local interference.				Scope connected to "Tape Out".	T203 for maximum noise output.
B	"				Center tuning meter.	Adjust T204 Secondary for zero center of meter.
C	Point of no local interference. Unit in mono mode.	Antenna terminal	Same as FM dial. 400Hz 75KHz dev.	1K $\mu\text{v}/\text{m}$	"Tape Out" with harmonic distortion analyzer.	Align T204 Primary for lowest total harmonic distortion.
D	"	"	"	"	"	Repeat B and C to get equal swing of center meter and lowest THD.
2. Muting threshold	"	"	"	5 $\mu\text{v}/\text{m}$	"	Adjust VR201 to switch "Muting" in and out giving approximately 70% attenuation of wave form swing on scope.

*Note: The above steps are required for touch up only. If it is necessary to align IF bandpass, connect RF sweep generator to FM antenna terminal and peak L5 on Front-end and T201, 202 on IF strip at TP of D204 to get proper flat-top bandpass response before Front end alignment.

COMPONENT SIDE

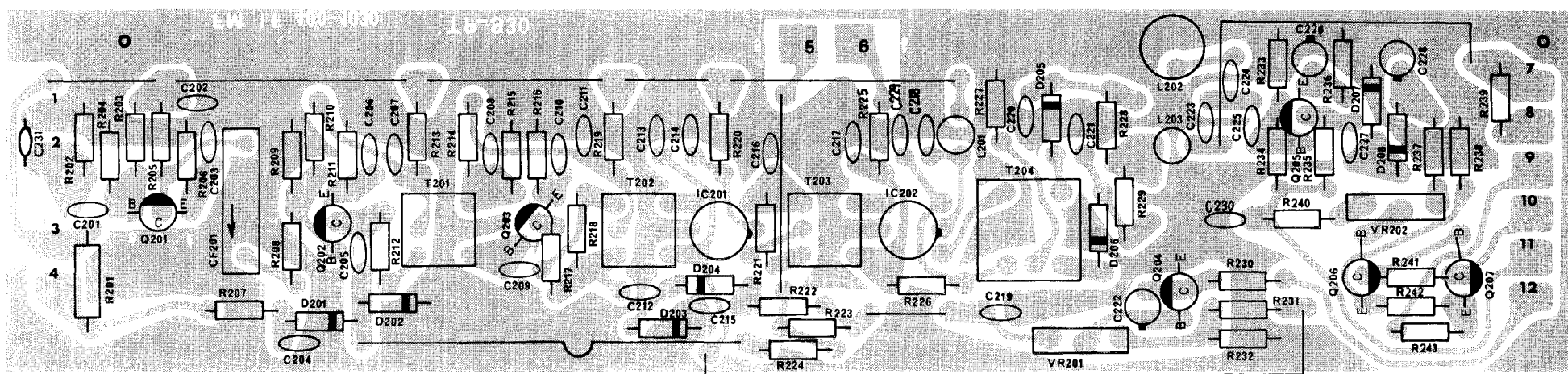

BOTTOM VIEW

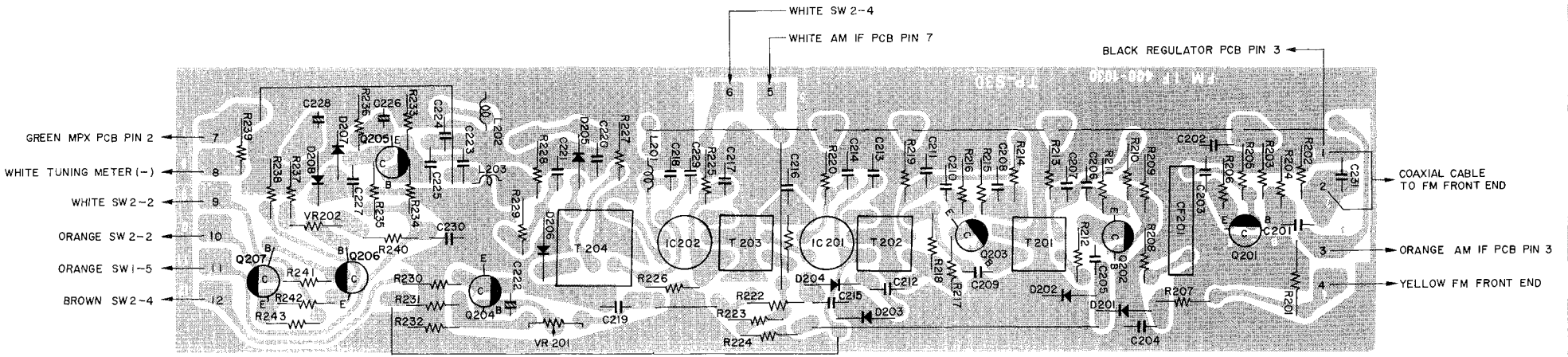

FM Front End

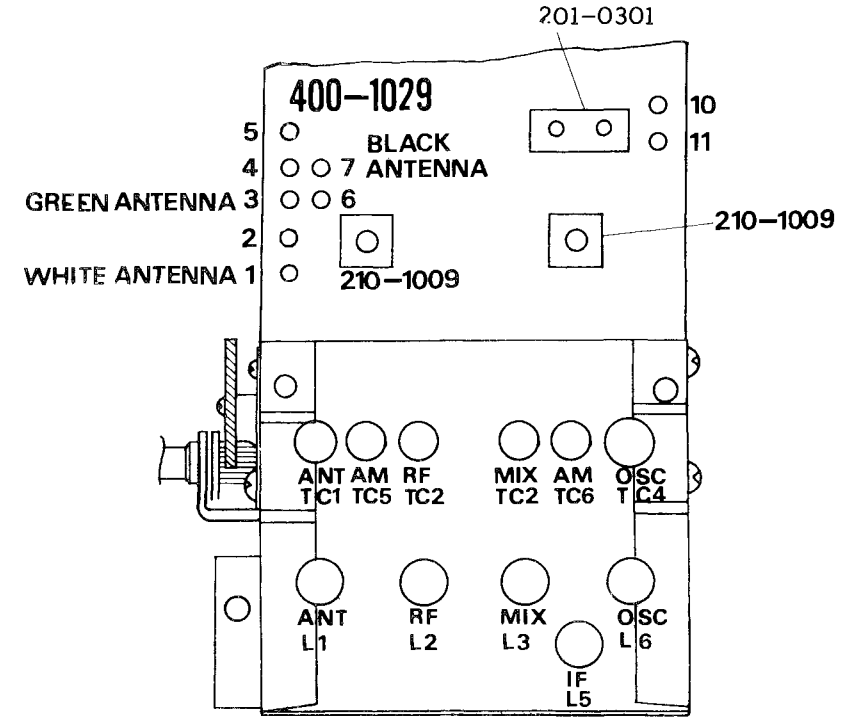
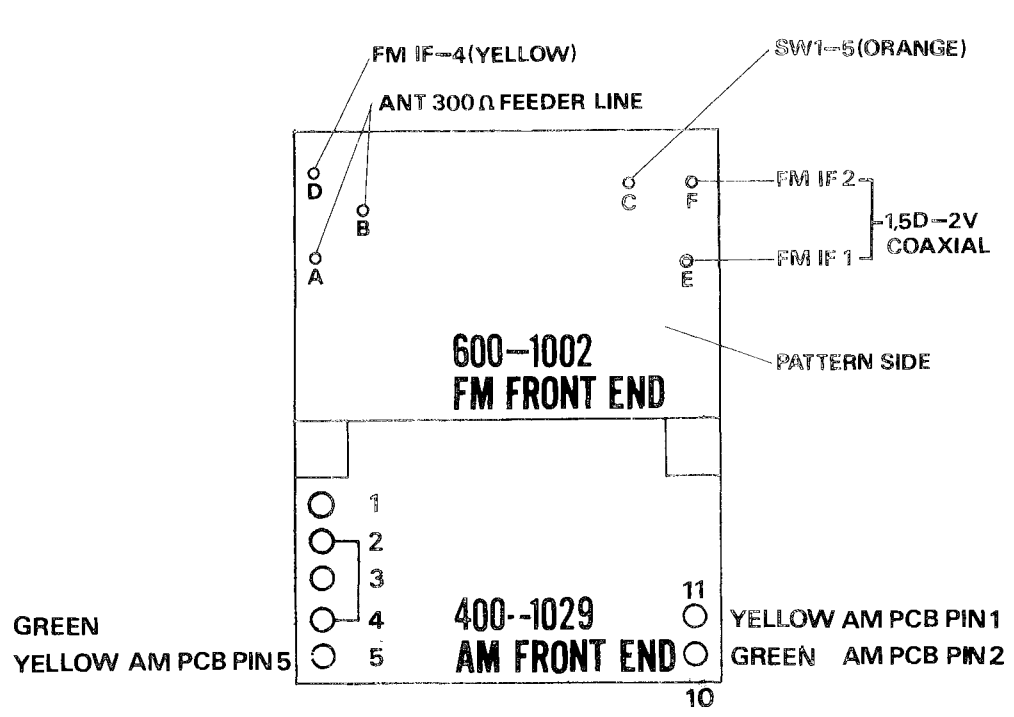
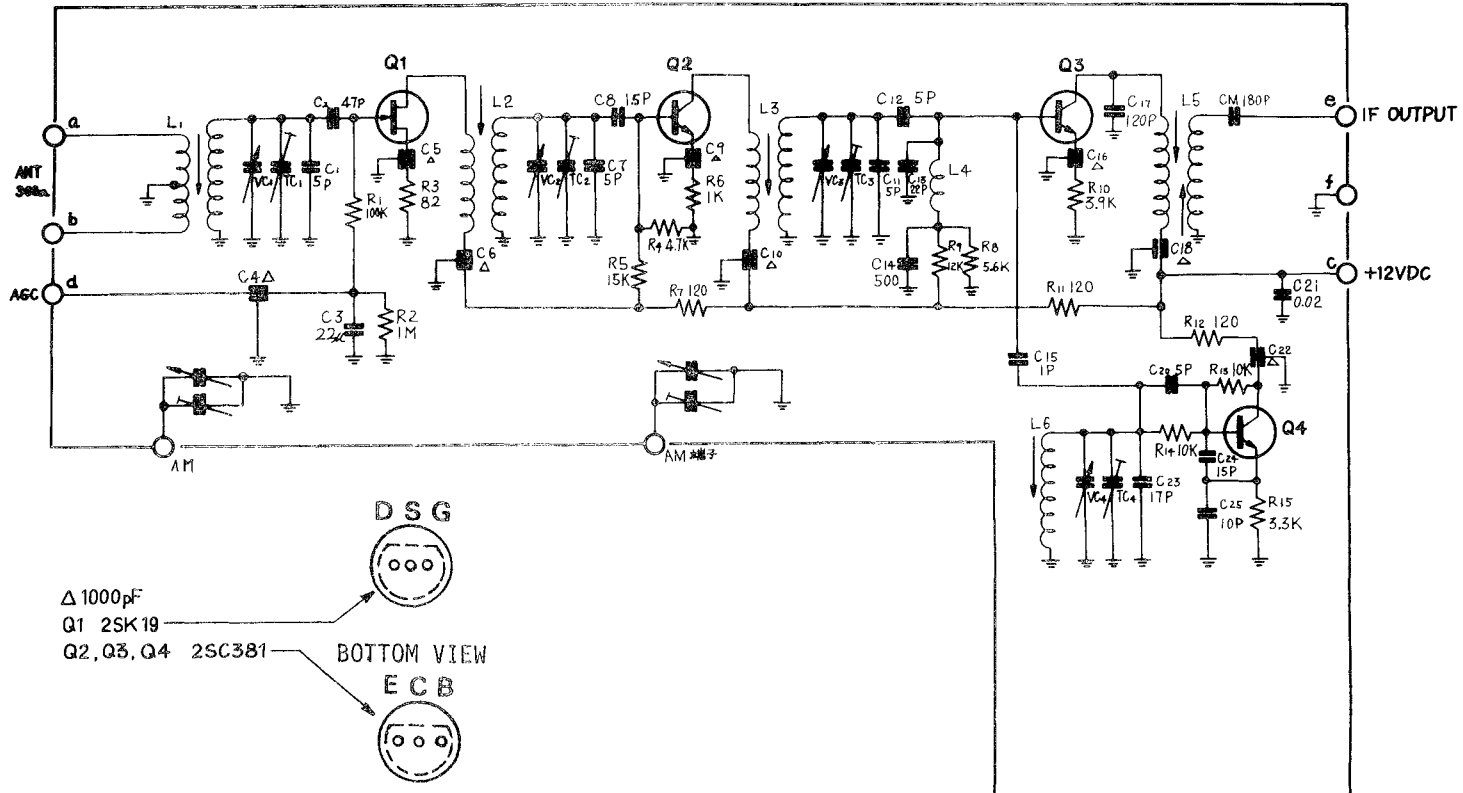

FM FRONT END ALIGNMENT

Step	Tuner switch & Dial setting	Coupling	Generator freq. and mod.	Generator RF output μV/m	Monitor	Adjustments and Indications
1-A Dial Calibration	FM station around 90MHz	-----	-----	-----	Tuning meter	If dial calibration error exceeds 300KHz, adjust oscillator coil L6 to correct dial error.
B	FM station around 106MHz	-----	-----	-----	"	If the calibration is incorrect, set the dial to 2 times the error in the opposite direction. Example: If the reading is 500 KHz high, set the dial 1MHz low. Align oscillator trimmer TC4 to receive station at new setting.
C	FM station around 90MHz	-----	-----	-----	"	Recheck station at 90MHz. Reset station to its correct location with the oscillator coil at L6. Repeat steps B & C, if necessary.
2. Antenna & Mixer	Point of no local interference around 90MHz. Point of no local interference around 106MHz.	Antenna terminals "	Same as FM dial. 400Hz 75KHz dev. "	As low as possible, keep noise in signal. "	Scope & meter on "Tape Out" terminal. "	Adjust FM antenna, coil L1, RF coil L2 and Mixer coil L3, for maximum symmetrical output. Adjust antenna trimmer TC1, RF trimmer TC2 and Mixer trimmer TC3 for maximum symmetrical output.

PARTS LIST

AM FRONT END		
SYMBOL #	DESCRIPTION	PART #
<u>Capacitors</u>		
C102	0.02 μ F ⁺⁸⁰ / _{-20%} 50wv YZ, Ceramic	291-2036-504
C103	0.047 μ F ⁺⁸⁰ / _{-20%} " " "	291-4736-504
C105	0.047 μ F " " " "	291-4736-504
C108	0.047 μ F " " " "	291-4736-504
C109	0.047 μ F " " " "	291-4736-504
C110	30pF \pm 10% 50wv N330, "	291-3001-503
C111	0.047 μ F ⁺⁸⁰ / _{-20%} 50wv YZ, "	291-4736-504
C114	470pF \pm 10% 5wv, Styrol	295-4711-500
<u>Inductors</u>		
T101	455kHz, Trap Coil LAC 30141 ASF	210-1012
T102	AM Oscillator Coil YXR-30250BC	210-1009
L101	1 μ H Ferro	213-1092
<u>Resistors</u>		
R104	18K \pm 10% $\frac{1}{2}$ W	414-1831-000
R105	3.3K " "	414-3321-000
R106	2.2K " "	414-2221-000
R107	27K " "	414-2731-000
R108	47K " "	414-4731-000
R109	1K " "	414-1021-000
R110	220 Ω " "	414-2211-000
R111	220 Ω " "	414-2211-000
R112	220 Ω " "	414-2211-000
<u>Semi-Conductors</u>		
Q101	2SC380A (0) Transistor	250-0380-603
Q102	2SC380A (0) Transistor	250-0380-603
<u>Miscellaneous</u>		
CF-101	455kHz, Ceramic Filter CFT-455B	201-0301

FM-IF		
SYMBOL #	DESCRIPTION	PART #
<u>Capacitors</u>		
C201	0.005 μ F ⁺⁸⁰ / _{-20%} 50wv Yz, Ceramic	291-5026-504
C202	0.02 μ F " " " "	291-2036-504
C203	0.02 μ F " " " "	291-2036-504
C204	0.02 μ F " " " "	291-2036-504
C205	220pF \pm 10% " N330 "	291-1511-503
C206	0.02 μ F ⁺⁸⁰ / _{-20%} " Yz, "	291-2036-504
C207	0.02 μ F " " " "	291-2036-504
C208	0.02 μ F " " " "	291-2036-504
C209	1.5pF \pm 0.25pF " NPO "	291-1593-500
C210	0.02 μ F ⁺⁸⁰ / _{-20%} " Yz, "	291-2036-504

FM-IF (cont'd)		
SYMBOL #	DESCRIPTION	PART #
<u>Capacitors</u>		
C211	0.02 μ F " " " "	291-2036-504
C212	10pF \pm 1pF " NPO "	291-1009-500
C213	0.047 μ F ⁺⁸⁰ / _{-20%} " " " "	291-4736-504
C214	0.02 μ F " " " "	291-2036-504
C215	0.02 μ F " " " "	291-5026-504
C216	0.02 μ F " " " "	291-2036-504
C217	0.02 μ F " " " "	291-2036-504
C218	0.02 μ F " " " "	291-2036-504
C219	0.01 ⁺⁸⁰ / _{-20%} 50wv Yz, Ceramic	291-1036-506
C220	100pF \pm 10% 50wv N330, Ceramic	291-1011-503
C221	100pF " " " "	291-1011-503
C222	0.47 μ F 10wv Single End Electrolytic	293-4740-100
C223	220pF \pm 10% 50wv, Ceramic N330	291-2211-503
C224	0.0018 μ F \pm 10% 50wv, Ceramic Z5p	291-1821-505
C225	220pF \pm 10% 50wv, Ceramic N330	291-2211-503
C226	1 μ F 16wv Single End, Electrolytic	293-1050-160
C227	0.02 μ F ⁺⁸⁰ / _{-20%} 50wv Yz, Ceramic	291-2036-504
C228	1 μ F 16wv Single End, Electrolytic	293-1050-160
C229	0.02 μ F ⁺⁸⁰ / _{-20%} 50 wv Yz, Ceramic	291-2036-504
C230	0.02 μ F " " " "	291-2036-504
C231	330pF \pm 10% " N330 "	291-3311-503
C232	47pF \pm 5% 50wv, Ceramic N750 - N1500	291-4705-507
C722	4.7 μ F/16 Single End, Electrolytic	293-4750-160
C723	4.7 μ F/16 Single End Electrolytic	293-4750-160

Inductors		
SYMBOL #	DESCRIPTION	PART #
T201	FM IFT 94AC-2007BHB	210-1104
T202	" " " "	210-1104
T203	" " " "	210-1104
T204	FM DET 95-5138	210-1107
L201	82 μ H \pm 10% Ferro Inductor	213-8201
L202	10mH \pm 10% " "	213-1031
L203	82 μ H \pm 10% " "	213-8201

Potentiometers		
SYMBOL #	DESCRIPTION	PART #
VR201	15K Ω Trim Pot 5DM	813-1531
VR202	15K Ω Trim Pot 5DM	813-1531

Resistors		
SYMBOL #	DESCRIPTION	PART #
R201	10M \pm 10% $\frac{1}{2}$ W	414-1061-000
R202	470 Ω \pm 10% $\frac{1}{2}$ W	414-4711-000
R203	27K \pm 10% $\frac{1}{2}$ W	414-2731-000
R204	4.7K Ω \pm 10% $\frac{1}{2}$ W	414-4721-000

FM-IF (cont'd)		
SYMBOL #	DESCRIPTION	PART #
<u>RESISTORS</u>		
R205	470 Ω " "	414-4711-000
R206	150 Ω " "	414-1511-000
R207	100K " "	414-1041-000
R208	470 Ω " "	414-4711-000
R209	4.7K " "	414-4721-000
R210	27K " "	414-2731-000
R211	150 Ω " "	414-1511-000
R212	220 Ω " "	414-2211-000
R213	220 Ω " "	414-2211-000
R214	27K " "	414-2731-000
R215	4.7K Ω " "	414-4721-000
R216	150 Ω " "	414-1511-000
R217	220 Ω " "	414-2211-000
R218	4.7K " "	414-4721-000
R219	220 Ω " "	414-2211-000
R220	47 Ω " "	414-4701-000
R221	4.7K " "	414-4721-000
R222	12K " "	414-1231-000
R223	10K " "	414-1031-000
R224	82K " "	414-8231-000
R225	33 Ω " "	414-3301-000
R226	47K " "	414-4731-000
R227	10K " "	414-1031-000
R228	22K \pm 5% $\frac{1}{2}$ W	414-2235-000
R229	22K \pm 5% $\frac{1}{2}$ W	414-2235-000
R230	33 Ω \pm 10% $\frac{1}{2}$ W	414-3301-000
R231	2.2K " "	414-2221-000
R232	39K " "	414-3931-000
R233	4.7K " "	414-4721-000
R234	47K " "	414-4731-000
R235	1K " "	414-1021-000
R236	68 Ω " "	414-6801-000
R237	3.9K " "	414-3921-000
R238	270 Ω " "	414-2711-000
R239	22K " "	414-2231-000
R240	56K " "	414-5631-000
R241	10K " "	414-1031-000
R242	3.9K " "	414-3921-000
R243	470 Ω " "	414-4711-000
R722	10K " "	414-1031-000

Semiconductors		
SYMBOL #	DESCRIPTION	PART #
Q201	2SC 380A (0) Transistor	250-0380-603
Q202	2SC 380A (0) Transistor	250-0380-603
Q203	2SC 380A (0) " "	250-0380-603
Q204	2SC 732 (BL) " "	250-0732-506

FM-IF (cont'd)		
SYMBOL #	DESCRIPTION	PART #
<u>Semiconductors</u>		
Q205	2SC 732 (BL) Transistor	250-0732-506
Q206	2SC 380A (0) " "	250-0380-603
Q207	2SC 380A (0) " "	250-0380-603
IC201	SL 20575 IC	280-2575
IC202	SL 20575 IC	280-2575
D201	1N60 Gi diode	230-1600
D202	1N60 " "	230-1600
D203	1N60 " "	230-1600
D204	1N60 " "	230-1600
D205	1N60 " " pair	230-1060
D206	1N60 " " pair	230-1060
D207	1N60 " "	230-1600
D208	1N60 " "	230-1600
<u>Miscellaneous</u>		
CF201	10.7MHz Ceramic Filter CF-10M-24	201-0201

MPX		
SYMBOL #	DESCRIPTION	PART #
<u>Capacitors</u>		
C301	10 μ F 25wv Electrolytic	293-1060-250
C302	10 μ F 25wv " "	293-1060-250
C303	0.0015 μ F \pm 10% 50wv Z5p Ceramic	291-1521-505
C305	0.0015 μ F \pm 10% 50wv Z5p Ceramic	291-1521-505
C307	10 μ F 25wv Electrolytic	293-1060-250
C308	4700pF \pm 10% 125wv Styrol	295-4721-121
C309	10 μ F 16wv Electrolytic	293-1060-160
C310	22 μ F 16wv Electrolytic	293-2260-160
C311	820pF \pm 10% 50wv Z5p Ceramic	291-8211-505
C312	1500pF \pm 10% 125wv Styrol	295-1521-121
C313	1 μ F 16wv Electrolytic	293-1050-160
C314	1 μ F 16wv Electrolytic	293-1050-160
C315	1 μ F 16wv " "	293-1050-160
C316	1 μ F 16wv " "	293-1050-160
C317	470 μ F 35wv " "	293-4770-350
C318	0.01 μ F \pm 10% 125wv Styrol	295-1031-121
C319	0.022 μ F \pm 10% 50wv Plastic	292-2231-500
C320	0.022 μ F \pm 10% 50wv Plastic	292-2231-500
C321	10 μ F 25wv Electrolytic	293-1060-250
C322	470 μ F 16wv " "	293-4770-160
<u>Inductors</u>		
T301	MPX 19kHz Coil Grn. CAN-1372 BET	210-1201

MPX (cont'd)		
SYMBOL #	DESCRIPTION	PART #
<u>Inductors</u>		
T302	MPX 67kHz Coil Blk. CAN-1373 GW	210-1203
T303	MPX 19kHz Coil Grn. CAN-1372 BET	210-1201
T304	MPX 19kHz Coil Yel. CAN-30162 GW	210-1204
T305	MPX 38kHz Coil Red CAN-1378 DRC	210-1202
<u>Resistors</u>		
R301	390KΩ ±5% 1/4W	414-3945-001
R302	82K ±10% 1/4W	414-8231-000
R303	2.2K " "	414-2221-000
R304	220K " "	414-2241-000
R305	680Ω " "	414-6811-000
R306	22Ω " "	414-2201-000
R307	3.9KΩ ±5% 1/4W	414-3925-001
R308	3.9KΩ " "	414-3925-001
R309	390K ±10% "	414-3941-000
R310	390K " "	414-3941-000
R311	39K " "	414-3931-000
R312	39K " "	414-3931-000
R313	4.7K ±10% 1/4W	414-4721-000
R314	4.7K " "	414-4721-000
R315	820Ω " "	414-8211-000
R316	820Ω " "	414-8211-000
R317	100K " "	414-1041-000
R318	100K " "	414-1041-000
R319	2.2K " "	414-2221-000
R320	1K " "	414-1021-000
<u>Semiconductors</u>		
Q301	2SC373 Transistor	250-0373-500
Q302	2SC373 "	250-0373-500
Q303	2SC373 "	250-0373-500
IC301	MA76A IC	280-7670
	IC skt. IC-09-14#2	113-0001
D301	1N60 Gi diode	230-1600
D302	1N60 " "	230-1600
<u>Miscellaneous</u>		
F301	Low Pass Filter	210-0101
F302	" " "	210-0101

PRE AMP		
SYMBOL #	DESCRIPTION	PART #
<u>Capacitors</u>		
C401	10μF 25WV Electrolytic	293-1060-250
C402	20pF ±10% 50WV NPO Ceramic	291-2001-500
C403	47μF 16WV Electrolytic	293-4760-160
C404	0.0047μF ±10% Ceramic	291-4721-505
C405	0.0015μF ±10% 50WV Z5p Ceramic	291-1521-505
C406	22μF 50WV Electrolytic	293-2260-500
C407	330μF 50WV Electrolytic (spec. size)	293-3370-500
C421	10μF 25WV Electrolytic	293-1060-250
C422	20pF ±10% 50WV NPO Ceramic	291-2001-500
C423	47μF 16WV Electrolytic	293-4760-160
C424	0.0047μF ±10% 50WV Z5p Ceramic	291-4721-505
C425	0.0015μF " " " Ceramic	291-1521-505
C426	22μF 50WV Electrolytic	293-2260-500
<u>Resistors</u>		
R402	220K ±10% 1/4W	414-2241-000
R403	180K ±5% 1/4W	414-1845-001
R405	390Ω ±10% 1/4W	414-3911-001
R406	1.2M ±10% 1/4W	414-1251-000
R407	4.7K ±5% 1/4W	414-4725-000
R408	1.2K ±5% 1/4W	414-1225-000
R409	100K ±10% 1/4W	414-1041-000
R410	2.2K ±10% 1/4W	414-2221-000
R411	1M ±10% 1/4W	414-1051-000
R412	47K ±10% 1/4W	414-4735-000
R413	3.3K ±5% 1/4W	414-3325-000
R422	220K ±10% 1/4W	414-2241-000
R423	180K ±5% 1/4W	414-1845-001
R425	390Ω ±10% 1/4W	414-3911-001
R426	1.2M ±10% 1/4W	414-1251-000
R427	4.7K ±10% 1/4W	414-4725-000
R428	1.2K ±5% 1/4W	414-1225-000
R429	100K ±10% 1/4W	414-1041-000
R430	2.2K ±10% 1/4W	414-2221-000
R431	1M ±10% 1/4W	414-1051-000
R432	47K ±10% 1/4W	414-4735-000
<u>Semiconductors</u>		
Q401	2SC1000(B1) Transistor	250-1000-506
Q402	2SC1000(B1) Transistor	250-1000-506
Q421	2SC1000(B1) Transistor	250-1000-506
Q422	2SC1000(B1) Transistor	250-1000-506

TONE CONTROL		
SYMBOL #	DESCRIPTION	PART #
<u>Capacitors</u>		
C501	220pF ±10% 50WV Z5p Ceramic	291-2211-505
C502	0.068μF ±10% 50WV Plastic	292-6831-500
C503	560pF ±10% 50WV Z5p Ceramic	291-5611-505
C504	390pF ±10% 50WV Z5p Ceramic	291-3911-505
C505	0.0033μF ±10% 50WV Z5p "	291-3321-505
C506	0.0033μF " " " "	291-3321-505
C507	0.22μF ±20% 50WV	292-2242-500
C508	0.22μF " " Plastic	292-2232-500
C509	5pF ±1pF 50WV GP Ceramic	291-5099-501
C510	47μF 16WV Single End	293-4760-160
C511	470μF 35WV " "	293-4770-350
C521	220pF ±10% 50WV Z5p Ceramic	291-2211-505
C522	0.068μF " " " Plastic	292-6831-500
C523	560pF ±10% 50WV Z5p Ceramic	291-5611-505
C524	390pF " " " "	291-3911-505
C525	0.0033μF ±10% 50WV Z5p "	291-3321-505
C526	0.0033μF " " " "	291-3321-505
C527	0.22μF ±20% " "	292-2242-500
C528	0.022μF " " " Plastic	292-2232-500
C529	5pF ±1pF 50WV GP Ceramic	291-5099-501
C530	47μF 16WV Single End	293-4760-160
<u>Potentiometers</u>		
VR501	150K Sx2 Loudness Pot	205-1001
VR502	500K L Balance Pot	205-1003
VR503	1M (B)x2 Tone Pot	205-1004
VR504	1M (B)x2 Tone Pot	205-1004
<u>Resistors</u>		
R501	4.7K ±10% 1/4W	414-4721-000
R502	6.8K " "	414-6821-000
R503	47K " "	414-4731-000
R504	100K ±5% "	414-1045-000
R505	100K ±10% "	414-1041-000
R506	100K ±5% "	414-1045-000
R507	22M ±10% 1/4W	412-2261-000
R508	2.2M " 1/4W	414-2251-000
R509	47K " "	414-4731-000
R510	6.8K " "	414-6821-000
R511	2.2KΩ " "	414-2221-000
R512	2.2KΩ ±10% 1/4W	414-2221-000
R513	4.7K " "	414-4721-000
R521	4.7K " "	414-4721-000
R522	6.8K " "	414-6821-000
R523	47K " "	414-4731-000

TONE CONTROL (cont'd)		
SYMBOL #	DESCRIPTION	PART #
<u>Resistors</u>		
R524	100K ±5% "	414-1045-000
R525	100K ±10% "	414-1041-000
R526	100K ±5% "	414-1045-000
R527	22M ±10% 1/4W	412-2261-000
R528	2.2M " 1/4W	414-2251-000
R529	47K " "	414-4731-000
R530	6.8K " "	414-6821-000
R531	2.2KΩ " "	414-2221-000
R532	2.2KΩ " "	414-2221-000
<u>DRIVER AMP</u>		
SYMBOL #	DESCRIPTION	PART #
<u>Capacitors</u>		
C601	10μF 25WV Single End Electrolytic	293-1060-250
C602	100μF 35WV Single End Electrolytic	293-1070-350
C604	47μF 35WV Single End Electrolytic	293-4760-350
C605	220μF 35WV Single End Electrolytic	293-2270-350
C606	22pF ±10% 50WV GP Ceramic	291-2201-505
C621	10μF 25WV Single End Electrolytic	293-1060-250
C624	47μF 35WV Single End Electrolytic	293-4760-350
C625	220μF 35WV Single End Electrolytic	293-2270-350
<u>Potentiometers</u>		
VR601	100Ω Trim Pot 5SM	812-1011
VR602	50KΩ 5SM	812-5031
VR621	100Ω Trim Pot	812-1011
<u>Resistors</u>		
R601	18K ±10% 1/4W	414-1831-000
R602	15K " "	414-1531-000
R603	33K " "	414-3331-000
R604	4.7K " "	414-4721-000
R605	4.7K ±5% "	414-4725-001
R606	6.8K ±10% "	414-6821-000
R607	120K ±5% "	414-1215-001
R608	2.2K ±10% "	414-2221-000
R609	2.2K " "	414-2221-000
R610	120K ±5% "	414-1215-001
R611	39Ω ±10% 1/4W	412-3901-000
R612	120K ±5% 1/4W	414-1215-000
R614	100 ±10% "	414-1011-000

PARTS LIST (cont'd.)

DRIVER AMP (cont'd)

SYMBOL #	DESCRIPTION	PART #
<u>Resistors</u>		
R622	15K ±10% "	414-1531-000
R624	4.7K " "	414-4721-000
R625	4.7K ±5% "	414-4725-001
R626	6.8K ±10% "	414-6821-000
R627	120K ±5% "	414-1215-001
R628	2.2K ±10% "	414-2221-000
R629	2.2K " "	414-2221-000
R630	120K ±5% "	414-1215-001
R631	39Ω ±10% ½w	412-3901-000
R632	120K ±5% ½w	414-1215-001
R634	100 ±10% "	414-1011-000
<u>Semiconductors</u>		
Q601	2SA640 (M) 2SA640 (L) Transistor	250-0640-1126L
Q602	MPS-U06 Transistor	260-0600
Q603	2SC485 (B1) "	250-0485-506
Q604	2SA485 (B1) "	250-0485-106
Q621	2SA640 (M) 2SA640 (L) Transistor	250-0640-112L
Q622	MPS-U06 Transistor	260-0600
Q623	2SC485 (B1) "	250-0485-506
Q624	2SA485 (B1) "	250-0485-106
D601	SD-1S	230-1001
D602	SD-1Y	230-1002
D603	SD-1Y	230-1002
D621	SD-1S	230-1001
D622	SD-1S	230-1001
D623	SD-1S	230-1001
<u>Miscellaneous</u>		
	Heat Sink	702-0007

HIGH FREQ. PRELOAD

SYMBOL #	DESCRIPTION	PART #
<u>Capacitors</u>		
C643	0.22μF ±20% 50wv Plastic	292-2242-500
C644	0.01μF ±20% YY Ceramic	291-1031-506
C663	0.22μF ±20% 50wv Plastic	292-2242-500
C664	0.01μF ±20% YY Ceramic	291-1031-506
<u>Inductors</u>		
L641	2.7 1w/1.5μH H.F. FILTER COIL	204-1002
L661	2.7 1w/1.5μH H.F. FILTER COIL	204-1002
<u>Resistors</u>		
R643	220Ω ±10% 2W Metal Film	402-2211-002
R646	22Ω " " " "	402-2201-002
R648	10Ω " 1W " "	401-1001-002
R663	220Ω " 2W " "	402-2211-002
R666	22Ω " " " "	402-2201-002
R668	10Ω " 1W " "	401-1001-002

AM-IF

SYMBOL #	DESCRIPTION	PART #
<u>Capacitors</u>		
C701	0.047μF ±20% 50wv YZ Ceramic	291-4736-504
C702	0.1μF ±10% 50wv Plastic	292-1041-500
C703	0.047μF ±20% 50wv YZ Ceramic	291-4736-504
C704	6pF ±0.5pF 50wv NPO "	291-6094-500
C705	0.047μF ±10% 50wv Ceramic	291-4736-504
C706	0.1μF ±10% 50wv Plastic	292-1041-500
C707	3pF ±0.5pF 50wv Ceramic	291-3094-500
C708	0.047μF ±10% 50wv Plastic	291-4736-504
C709	0.0047μF ±10% 50wv Z5p Ceramic	291-4721-505
C710	0.1μF ±10% 50wv Plastic	292-1041-500
C711	470pF ±10% 50wv Z5p Ceramic	291-4711-505
C712	470pF ±10% 50wv Z5p Ceramic	291-4711-505
C713	0.0018μF ±10% 50wv Z5p "	291-1821-505
C714	0.0022μF " " " "	291-2221-505
C715	0.47μF ±20% 16wv A1	298-4742-160
C716	0.0047μF ±10% 50wv Z5p Cer.	291-4721-505
C717	47μF 16wv Electrolytic	293-4760-160
C718	0.047μF ±20% 50wv YZ Ceramic	291-4736-504
C719	2μF 16wv Electrolytic	293-2050-160
C720	0.047μF ±20% 50wv YZ Ceramic	291-4736-504
C721	10μF 16wv (NP) Electrolytic	299-1060-160
<u>Inductors</u>		
T701	AM IFT	210-1013
T702	" "	210-1010
T703	" " YHE-21158AYK	210-1011
L701	10mH ±10% Ferro	213-1031
L702	10mH ±10% "	213-1031
L703	56mH ±10% "	213-5631
<u>Resistors</u>		
R701	3.3k ±10% ½w	414-3321-000
R702	4.7K " "	414-4721-000
R703	100K " "	414-1041-000
R704	560Ω " "	414-5611-000
R705	220Ω " "	414-2211-000
R706	220Ω " "	414-2211-000
R707	10K " "	414-1031-000
R708	56K ±10% ½w	414-5631-000
R709	150Ω " "	414-1511-000
R710	220Ω " "	414-2211-000
R711	220Ω " "	414-2211-000
R712	1K " "	414-1021-000
R713	220K " "	414-2241-000
R714	22K " "	414-2231-000
R715	22K " "	414-2231-000
R716	180Ω " "	414-1811-000
R717	6.8K " "	414-6821-000

AM-IF (cont'd)

SYMBOL #	DESCRIPTION	PART #
<u>Resistors</u>		
R718	27K " "	414-2731-000
R719	6.2K " "	414-6221-000
R720	15K " "	414-1531-000
R721	68K " "	414-6831-000
<u>Semiconductors</u>		
Q701	2SC380A (0) Transistor	250-0380-603
Q702	2SC380A (0) "	250-0380-603
D701	1N34A Gi diode	230-1340
D702	1N34A " "	230-1340
D703	1N34A " "	230-1340
D704	1N34A " "	230-1340

DC REGULATOR

SYMBOL #	DESCRIPTION	PART #
<u>Capacitors</u>		
C554	1000μF 35wv Tubular type Electrolytic	293-1082-350
C555	220μF 35wv Single end Electrolytic	293-2270-350
C556	100μF 16wv Single end Electrolytic	293-1070-160
C557	100μF 16wv Single end Electrolytic	293-1070-160
C558	10μF 16wv Single end Electrolytic	293-1060-160
C559	100pF ±10% 50wv N330 Ceramic	291-1011-503
<u>Potentiometers</u>		
VR551	1KΩ Trim pot 5DM	813-1021
<u>Resistors</u>		
R551	22Ω ±10% 2w Metal film	402-2201-002
R552	1.2K ±10% ½w " "	414-1221-000
R553	1.5K " " " "	414-1521-000
R554	2.7K " " " "	414-2721-000
R555	1.8K " " " "	414-1821-000
R556	100Ω " ½w " "	412-1011-000
<u>Semiconductors</u>		
Q551	2SC372 (Y) Transistor	250-0372-504
Q552	SE1001 "	260-1001
Q553	2SD313 (D) Power Transistor	250-0313-704

POWER AMP

SYMBOL #	DESCRIPTION	PART #
<u>Capacitors</u>		
C801, C802, C803, C804	0.0047μF ±10% 50wv Z5p Ceramic	291-4721-505
C805, C806	0.011μF ±10% 50wv Plastic	292-1031-500
C807	2pF ±0.25pF 50wv NPO, Ceramic	291-2093-500
C808	0.001μF 1.4Kv (UL & CSA) Ceramic	291-1021-142
C809, C810	0.0047μF 1.4Kv (UL & CSA) Ceramic	291-4721-142
C811, C812	0.22μF ±20% 50wv, Plastic	292-2242-500

POWER AMP (cont'd)

SYMBOL #	DESCRIPTION	PART #
<u>Capacitors</u>		
C641, C661	2200μF 35wv Single End Electrolytic	293-2280-350
C642, C645, C655, C662	0.22μF ±20% 250wv, MP	296-2242-250
<u>Resistors</u>		
R613, R635, R641, R642, R661, R662, R645, R665, R801, R802, R803, R804, R805, R806, R807	1K ±10% ½w 0.82Ω ±10% 5w 33Ω ±10% ½w 4.7K ±10% ½w 1.2K ±10% ½w 220Ω ±10% ½w 2.7M ±10% ½w 1M ±10% ½w 10Ω ±10% ½w	414-1021-000 405-8281-004 414-3301-000 414-4721-000 412-1221-000 412-2211-000 412-2751-000 412-1051-000 412-1001-000

MAIN CHASSIS

SYMBOL #	DESCRIPTION	PART #
<u>Capacitors</u>		
C814	4700μF 70wv Single End Electrolytic	293-4780-700
<u>Inductors</u>		
L801, L802	Power Transformer (UL & CSA) Line Filter Coil 1μH AM Loopstick Ant. 2z 172	203-1010 211-1000 214-1007
<u>Semiconductors</u>		
D801	1S1555 Si diode Rectifier 4B20	230-1155 242-4020
Q641, Q642, Q661, Q662	2SD201 Power Transistor	250-0201-777
<u>Resistors</u>		
D641, D661	STV-3 Stabistor	290-3000
<u>Miscellaneous</u>		
	Power fuse 1.5A 125v (UL & CSA) #85D	112-1500
Sw-1	Speaker fuse 2.8A 250v Rotary switch Y394	112-2800 206-1100
Sw-2	7 Button push switch	206-1001
V1-V8	Pointer Lamp 8v 40mA	208-0840
Y9-V12	Pilot lamp 6.3v 250mA	208-6250-001
V13	Function lamp 6v 100mA Stereo Indicator lamp 28v 40mA	208-6100 208-2840
	Tuning wheel assembly	702-0002
	Pointer	703-0005
	Drum spring	716-0001
<u>Cosmetics</u>		
	Signal strength meter A54	207-1002
	Tuning meter SB-54	207-1003
	End piece	701-0001
	Front panel	702-0003
	Control decal	702-0004
	Push button (L)	703-0001
	Tuning escutcheon	703-0006
	Leg	704-0003
	Knob, tuning	705-0009
	Knob, loudness, function balance	705-0010
	Knob, tone front	705-0011
	Knob, tone rear w/fin	705-0012
	Wooden cabinet	707-0001
	Ant. label	709-0008
	Serial Number label	709-0009
	Plexiglass	713-0002
	Dial scale	713-0003
	Function Ind. plate	713-0004
	Stereo ind. plate	713-0005
<u>Complete Subassemblies</u>		
	Pre Amp	400-1004
	Tone Control	400-1005
	Driver Amp	400-1031
	High Frequency Preload	400-1010
	DC Regulator	400-1026
	MPX	400-1025
	FM-IF	400-1030
	AM-IF	400-1015
	AM Front End	400-1029
	FM Front End	600-1002

