

ASSEMBLING
AND USING
YOUR

Heathkit

"WILLIAMSON TYPE"
AMPLIFIER
MODEL W-2

595-50

HEATH COMPANY

BENTON HARBOR,
MICHIGAN

PRICE \$1.00

THE WORLD'S *Finest* TEST EQUIPMENT IN KIT FORM

STANDARD COLOR CODE — RESISTORS AND CAPACITORS

AXIAL LEAD RESISTOR	INSULATED UNINSULATED Color	FIRST RING BODY COLOR First Figure	SECOND RING END COLOR Second Figure	THIRD RING DOT COLOR Multiplier	DISC CERAMIC RMA CODE
	BLACK	0	0	None	
	BROWN	1	1	10	
	RED	2	2	100	
	ORANGE	3	3	1,000	
	YELLOW	4	4	10,000	
	GREEN	5	5	100,000	
	BLUE	6	6	1,000,000	
	VIOLET	7	7	10,000,000	
	GRAY	8	8	100,000,000	
	WHITE	9	9	1,000,000,000	

The standard color code provides all necessary information required to properly identify color coded resistors and capacitors. Refer to the color code for numerical values and the zeroes or multipliers assigned to the colors used. A fourth color band on resistors determines tolerance rating as follows: Gold = 5%, silver = 10%. Absence of the fourth band indicates a 20% tolerance rating.

The physical size of carbon resistors is determined by their wattage rating. Carbon resistors most commonly used in Heathkits are 1/2 watt. Higher wattage rated resistors when specified are progressively larger in physical size. Small wire wound resistors 1/2 watt, 1 or 2 watt may be color coded but the first band will be double width.

MOLDED MICA TYPE CAPACITORS

<p>CURRENT STANDARD CODE</p> <p>JAN 6 1948 RMA CODE</p>	<p>RMA 3-DOT (OBSOLETE) RATED 500 W.V.D.C. ± 20% TOL.</p>	<p>BUTTON SILVER MICA CAPACITOR</p>
<p>RMA (5-DOT OBSOLETE CODE)</p>	<p>RMA 6-DOT (OBSOLETE)</p>	<p>RMA 4-DOT (OBSOLETE)</p>

MOLDED PAPER TYPE CAPACITORS

<p>TUBULAR CAPACITOR</p> <p>Normally stamped for value</p> <p>A 2 digit voltage rating indicates more than 900 V. Add 2 zeros to end of 2 digit number.</p>	<p>MOLDED FLAT CAPACITOR Commercial Code</p>	<p>JAN. CODE CAPACITOR</p>
--	---	-----------------------------------

The tolerance rating of capacitors is determined by the color code. For example: red = 2%, green = 5%, etc. The voltage rating of capacitors is obtained by multiplying the color value by 100. For example: orange = 3×100 or 300 volts. Blue = 6×100 or 600 volts.

In the design of Heathkits, the temperature coefficient of ceramic or mica capacitors is not generally a critical factor and therefore Heathkit manuals avoid reference to temperature coefficient specifications.

HEATHKIT "WILLIAMSON TYPE" AMPLIFIER

MODEL W-2

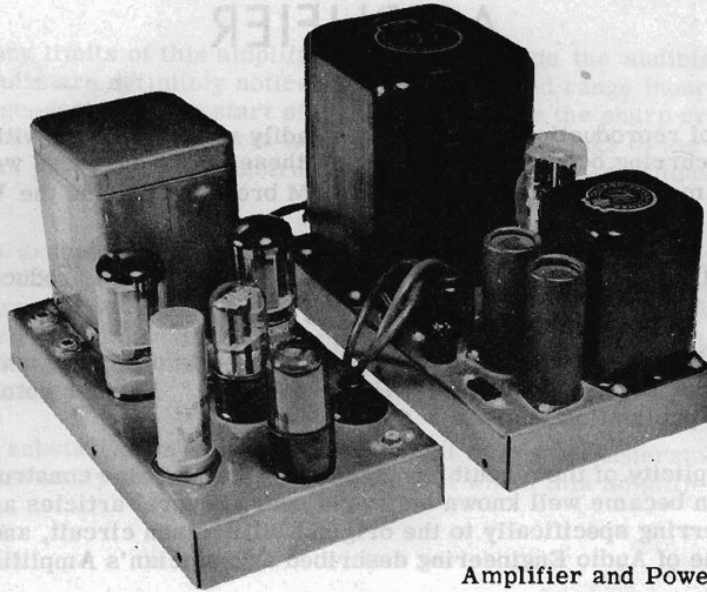

Amplifier and Power Supply (W-2M)

TECHNICAL SPECIFICATIONS

Preamplifier (WA-P1)

Tube Complement	1 - 12AY7 (or 12AX7) and 1 - 12AU7.
Switch selected inputs	2 - low gain for crystal pickup and tuner. 1 - high gain for magnetic pickup.
Switch selected turn-over	for 78 RPM and LP on high gain channel.
Bass tone control at 20 cycles	boosts 15 db max., cuts 15 db max.
Treble tone control at 20KC	boosts 15 db max., cuts 15 db max.
Input voltage at 1KC for 1.2 volts output . .	0.2 volts across 1 megohm on low gain channels. 0.004 volts across 22K on high gain channel
Power requirements	220V DC at 6 mA and 6.3V at 600 mA.
Dimensions less shafts and knobs	2 $\frac{1}{4}$ " high x 10 $\frac{1}{4}$ " wide x 7 $\frac{1}{4}$ " deep.

Amplifier and Power Supply (W-2M)

Tube Complement	2 - 6SN7GT; 2-5881; 1 - 5V4G
Frequency response	within 1 db from 10 cycles to 100 KC.
Harmonic distortion at 5 watt output	less than 0.5% between 20 cycles and 20 KC.
IM distortion at 5 watt equivalent output . .	0.5% using 60 and 3000 cycles.
Output impedance	4, 8 or 16 ohms .
Input voltage for 5 watt output75 volts across 2.2 megohms
Power requirements	105-125 volts 50/60 cycles 120 watts.
Overall dimensions (each unit)	7" high x 5 $\frac{1}{2}$ " wide x 11" long.

THE HEATHKIT "WILLIAMSON TYPE" AMPLIFIER

The art and science of reproduction of sound has steadily made advances with improvements of major importance occurring occasionally. Amongst these major advances we count the LP type records, the modern magnetic type phono pickups, FM broadcasting and the Williamson amplifier circuit.

These advances in different links in the chain of devices needed for reproduction of sound were made when each link appeared to become the weakest one.

In the summer of 1947 Mr. D. T. N. Williamson had the results of his search for a perfect amplifier published in the British periodical "Wireless World." Further notes on this amplifier appeared in the same publication in 1949.

The comparative simplicity of the circuit tempted many skilled home constructors, and the remarkable results soon became well known the world over. Several articles appeared in American publications, referring specifically to the original Williamson circuit, and the article in the November, 1949, issue of Audio Engineering described a "Musician's Amplifier" patterned after the "Williamson."

Not all attempts to duplicate the original performance with other components and different layouts were successful. Thus there developed a thriving trade of importing the components used in the original design, largely to replace parts in existing amplifiers that were lacking in performance.

The Heathkit amplifier closely follows the very successful Musician's Amplifier, and is considered by many to surpass the original Williamson.

The original article by Mr. Williamson outlined the six basic requirements for a perfect amplifier as follows: 1. Negligible non-linear distortion. 2. Linear frequency response and power handling capacity over the range of 10 cycles to 20kc. 3. Negligible phase shift over the same range. 4. Good transient response. 5. Low output resistance. 6. Adequate power reserve.

All six requirements are properly fulfilled in the Heathkit amplifier through the careful choice of component parts and selection of optimum operating conditions.

The operational qualities were of primary concern and thus electrical efficiency has been sacrificed wherever needed. The first requirement of Mr. Williamson calls for the use of only the most linear portion of the tube characteristics. Although that portion has been extended by higher than normal plate supply voltages, it is only a fraction of the curve normally used in amplifiers. Thus a comparatively low output power level is obtained with tubes capable of much more efficient operation under less stringent requirements.

A recent modification of this circuit has been described by David Sarser and Melvin C. Sprinkle in "Audio Engineering" for July, 1952. This article, titled "Gilding the Lily," points out several changes which increase the efficiency of the circuit without perceptible degradation of its performance. The instructions in this manual incorporate these changes. However, instructions are given on page 32 for building the amplifier in accordance with the original design.

Either circuit, at levels up to five watts output, affords performance far beyond the finest speaker systems available today. Average power output for home listening rarely exceeds 1 watt. The circuit as described in the assembly instructions will provide a power output of 12 to 15 watts before intermodulation distortion becomes noticeable, even to the trained ear. The circuit described on page 32, as originally used by Williamson, displays similar characteristics at levels of 8 to 10 watts.

While the frequency limits of this amplifier are quite outside the audible range of single frequencies, the results are definitely noticeable. The extended range insures exact reproduction of the transients generated at the start of each note, such as the sharp crash of the cymbal, the brief scratching of the bow as it starts to move across the strings of the violin, or the deep thud of the kettle-drum. The individual instruments in an orchestra are thus quite readily distinguished.

Mr. Williamson's second requirement of both linear frequency response and power handling capability and the third requirement of negligible phase shift call for an output transformer with quite extraordinary characteristics. An incorrectly designed transformer may produce distortion that is easily mistaken for faulty operating conditions of the tubes. The transformer used in the Heathkit amplifier has the characteristics required and may well be considered the heart of the amplifier.

Considering your substantial investment in this kit, it is readily understood that it warrants the greatest care in assembly to reap the performance of which this amplifier is capable.



Preamplifier WA -P1

ASSEMBLY AND OPERATION OF THE MODEL W-2 HEATHKIT "WILLIAMSON TYPE" AMPLIFIER

This Heathkit amplifier was developed to provide an excellent link in the chain of devices that are required for the highest quality reproduction of sound in the home. To obtain maximum enjoyment from such a chain, the other links (record, stylus, pickup, turntable, speaker and enclosure, for instance) should be likewise of the highest quality.

To realize the full capabilities of this amplifier, the construction should be carried out with the utmost of care. Hurried and careless construction may readily lead to difficulties, either initially or after some period of satisfactory operation. Therefore, take the time to do a good job.

This manual has been prepared to help you construct the amplifier with the least possible chance of error. Please read it all the way through before starting any of the work.

UNPACK THE KIT CAREFULLY AND CHECK EACH PART AGAINST THE PARTS LIST.

This will enable you to become acquainted with the parts, and will assist you in determining if any small parts may still be tucked in with the packing material. If you find a part missing and you are certain it is not discarded with the packing material, attach the inspection slip to your claim and notify us promptly of the shortage. Screws, nuts and washers are counted mechanically, and if a few are missing, please secure them locally. Use the charts on the inside covers of this manual to identify the parts.

Read the note on soldering on the inside of the back cover. Make a good mechanical connection with clean metal to clean metal. Use only good quality rosin core radio type solder. Pastes or acids are difficult to remove and even minute quantities left combine with moisture from the air to form a corrosive product. Weeks or months later corrosion may result in untimely failure.

NOTE: ALL GUARANTEES ARE VOIDED AND WE WILL NOT REPAIR OR SERVICE INSTRUMENTS IN WHICH ACID CORE SOLDER OR PASTE FLUXES HAVE BEEN USED. (When in doubt about solder, it is recommended that a new roll plainly marked "Rosin Core Radio Solder" be purchased.)

Small changes in parts may be made by the Heath Company. Any part supplied will work just as well as the part for which it was substituted. By reading the color code on the resistors, for instance, it will be readily understood that a value of 51,000 ohms is a substitute for the specified 47,000 ohms, or a resistor coded 82,000 ohms is a substitute for the specified 100,000 ohm unit, provided the specified values are not supplied. Such changes will only be made if the specified parts are unobtainable at the time, and are made only to insure a minimum delay in filling your order.

Resistors and controls have a tolerance rating of plus or minus 20% unless otherwise stated. Therefore, a 100K resistor may test between 80K and 120K ohms. The letter K stands for 1,000 and M or meg stands for 1,000,000. Some manufacturers use M for 1,000. Consulting the parts list will clarify any parts in question. Frequently condensers show an even greater variation such as minus 50% and plus 100%. This Heathkit is designed to accommodate such variations.

STEP-BY-STEP ASSEMBLY

The Heathkit model W-2 Amplifier comes in three sections: the power supply, the main amplifier, and the preamplifier. The power supply and main amplifier are designated as the W-2M, the preamplifier is designated the WA-P1. The three units make up the W-2.

Fasten the large pictorial of the unit under construction to the wall over the work space available. The small reproduction in the manual is intended for reference later on after the large copy has become mutilated or lost.

Many parts are supplied by the manufacturer with leads that are longer than the particular application requires. These leads should be cut to proper length as the parts are wired into place. This will result in both superior operation and neater appearance.

Use spaghetti (insulated sleeving) over bare wires on condensers and resistors where necessary to prevent the leads from accidentally touching other bare wires or metal parts.

Use lockwashers under all 6-32, 8-32 and control nuts.

Check off each step in the space provided (✓) as it is completed.

(S) means solder the connection (NS) means do not solder yet.

POWER SUPPLY

- () Mount the two condenser mounting wafers on top of the chassis, as shown, with 6-32 screws and nuts. Note the position of the triangular cutout. Under the chassis include a 1-lug terminal strip under the nut indicated.
- () Mount the two saddle mounting type octal sockets from below the chassis with 6-32 screws and nuts. Observe that the keyways in the sockets are pointed inward or towards each other.
- () Mount the 110 volt socket from below the chassis with 6-32 screws and nuts.
- () Mount the fuse holder with the nut and lockwasher supplied, and install the fuse. When necessary replace with a type 3AG rated at not more than 3 amperes.

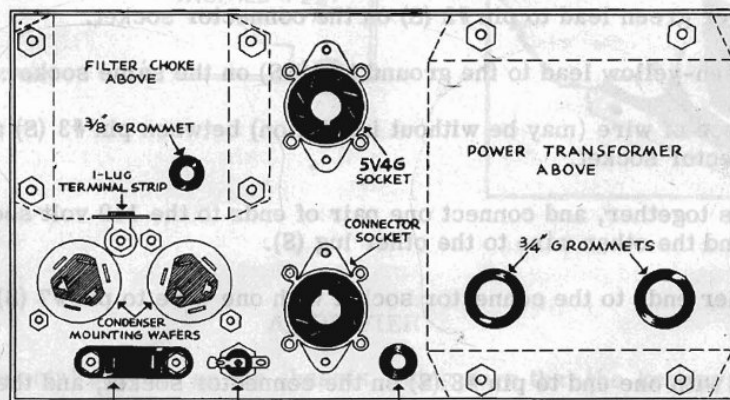

POWER SUPPLY CHASSIS LAYOUT . . Bottom View

- () Install the two 3/8 grommets for the line cord and the filter choke, and the two 3/4 grommets for the transformer leads.
- () Mount the power transformer on top of the chassis with the leads through the 3/4 grommets. Use 8-32 screws and nuts.
- () Mount the filter choke on top of the chassis, with the leads through the 3/8 grommet. Use 8-32 screws and nuts.
- () Install the two 50 MFD-350 volt electrolytic condensers. Observe the position of the lugs in the sketch and install from the top of the chassis by passing the mounting prongs through the slots in the wafer. After making sure that the condenser is snugly seated against the wafer, twist each of the mounting prongs one eighth turn with a pair of pliers.
- (✓) Twist together the transformer leads that come out of the hole nearest the corner, and place to the 5V4G tube socket. After cutting each wire to length and stripping the insulation off the ends, connect the red-yellow lead to the ground lug (S) on the 5V4G socket.
- (✓) Connect one red lead to pin #6 (S) on the 5V4G socket.
- (✓) Connect other red lead to pin #4 (S) on the 5V4G socket.
- (✓) Connect one yellow lead to pin #2 (S) on the 5V4G socket.
- (✓) Connect other yellow lead to pin #8 (NS) on the same socket.
- (✓) Twist together the black transformer leads that come out of the hole nearest the center and place to the 110 volt socket.
- (✓) After cutting the leads to length and stripping the insulation off the ends, connect the one black to the one socket lug (NS) and the other black lead to the other socket lug (NS).
- (✓) Twist together the remaining transformer leads that come out of the hole nearest the center and place them to the connector socket.
- (✓) After cutting the leads to length and stripping the insulation off the ends, connect one green lead to pin #1 (S) on the connector socket.
- (✓) Connect the other green lead to pin #2 (S) on the connector socket.
- (✓) Connect the green-yellow lead to the ground lug (NS) on the same socket.
- (✓) Use a small piece of wire (may be without insulation) between pin #3 (S) and the ground lug (S) on the connector socket.
- (✓) Twist two wires together, and connect one pair of ends to the 110 volt socket with one wire to one lug (S) and the other wire to the other lug (S).
- (✓) Connect the other ends to the connector socket with one wire to pin #7 (S) and the other wire to pin #8 (NS).
- (✓) Connect a wire with one end to pin #8 (S) on the connector socket, and the other end to the end lug (S) on the fuse holder.
- (✓) Connect a wire with one end to pin #4 (S) on the connector socket, and the other end to the lug (NS) on the nearest filter condenser.

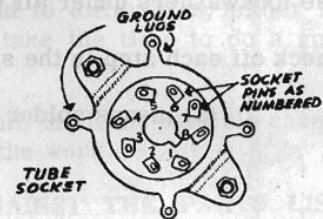

- (✓) Connect the black lead from the filter choke to the lug (S) on the nearest filter condenser.
- (✓) Connect the red lead from the filter choke to pin #8 (NS) on the 5V4G socket.
- (✓) Connect a 20 MFD-350 volt electrolytic tubular condenser with the lead from the end marked positive or + to pin #8 (S) on the 5V4G socket, and the other lead to the 1-lug terminal strip (S).
- (✓) Connect another 20 MFD-350 volt condenser with the lead from the end marked positive to the 1-lug terminal strip (S) and the other lead to the ground lug (S) on the 5V4G socket.
- (✓) Connect a wire between a twisted mounting prong (S) on the condenser nearest the connector socket, and the lug (S) on the second condenser.
- (✓) Connect a wire between a twisted mounting prong (S) on the second condenser, and a ground lug (S) on the 5V4G socket.
- (✓) Place the end of the line cord through the 3/8 grommet from the top of the chassis, and tie a knot for strain relief, so it cannot be pulled out.
- (✓) Connect the line cord with one wire to the side lug (S) on the fuse holder, and with the other wire to pin #6 (S) on the connector socket.
- (✓) Check the wiring very carefully against the pictorial and make sure each connection is properly soldered. Shake out any excess solder and loose short pieces of wire.
- (✓) Install the four rubber feet in one of the bottom plates, and attach this plate to the bottom of the chassis with six #6 sheet metal screws.
- (✓) Install the 5V4G tube in the socket between the power transformer and the filter choke.

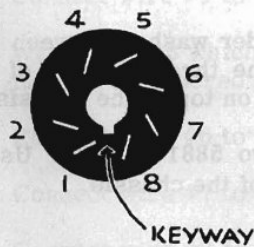

AMPLIFIER

- (✓) Mount the five octal sockets on the chassis, being sure that the keyways are positioned as shown. The sockets are secured in place with the wavy retaining ring. Start one end of the ring in the groove in the socket and then work the rest of the ring around the socket and into the groove with a screwdriver.

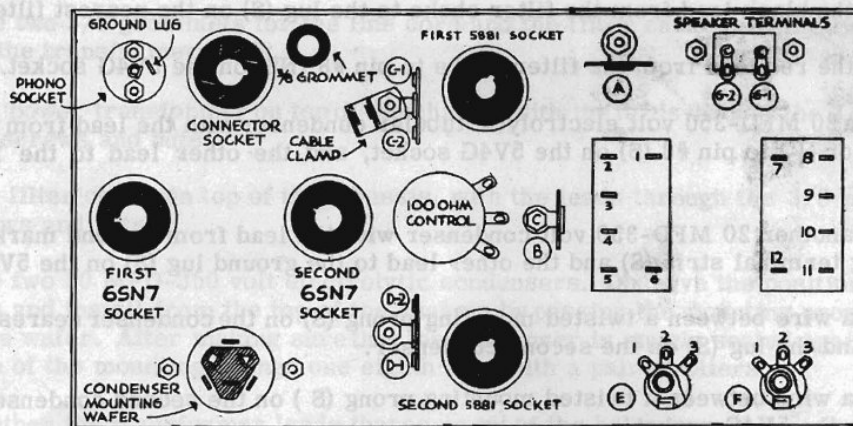

AMPLIFIER CHASSIS LAYOUT - *Bottom View*

- (✓) Mount the phono input socket from below the chassis with 6-32 screws and nuts.
- (✓) Mount the condenser mounting wafer on top of the chassis with 6-32 screws and nuts. Note the position of the triangular cutout.
- (✓) Mount the 2-screw speaker terminal strip on top of the chassis with 6-32 screws and nuts.
- (✓) Mount one 1-lug terminal strip A near the speaker terminal under the chassis with a 6-32 screw and nut.
- (✓) Mount another 1-lug terminal strip B between the 5881 sockets under the chassis with a 6-32 screw and nut.
- (✓) Mount a 2-lug terminal strip D near the second 5881 socket under the chassis with a 6-32 screw and nut.
- (✓) Mount the two closed circuit phone jacks E and F with a fibre shoulder washer between the jack and the underside of the chassis so that the shoulder centers the threaded part of the jack in the hole, and a flat fibre washer, a nickel washer, and a nut on top of the chassis.
- (✓) Mount the 100 ohm control from below the chassis between the two 5881 sockets. Use a control lockwasher between the control bushing and the under side of the chassis.
- (✓) Install the 3/8 grommet near the connector socket.
- (✓) Use a length of 8-wire cable (not longer than three feet) for connection between amplifier and power supply. Note that if the installation requires a longer cable between these two units other cable should be obtained locally. For a distance not exceeding 3 feet, the cable supplied with the kit (all wires #22 gauge) is suitable. For a distance not exceeding 4 feet, an 8-wire cable with at least two #20 gauge wires may be used. For a distance not exceeding 6 feet, a cable with two #18 gauge wires (such as Belden #8448) may be used. For distances up to 9 feet, two conductors in the cable should be #16 gauge.
- (✓) Remove the overall insulation (plastic or braid) on one end for a distance of a good 6 inches and place this end through the 3/8 grommet. Bend open the 3/16 plastic cable clamp and slip it around the cable at the point where the overall insulation ends.
- (✓) Install the second 2-lug terminal strip C together with the cable clamp using the long 6-32 screw and a nut.

- (✓) Mount the output transformer on top of the chassis, using 8-32 screws with lock-washers under the screwheads. The terminals marked 1 through 6 go toward the tube sockets.
- (✓) Mount the 20-20 MFD-450 volt + 20 MFD - 25 volt electrolytic condenser on top of the chassis by passing the mounting prongs through the slots in the mounting wafer. Make sure the unmarked lug is toward the edge of the chassis, and while holding the condenser snugly against the wafer, twist each of the three mounting prongs one-eighth turn with a pair of pliers.

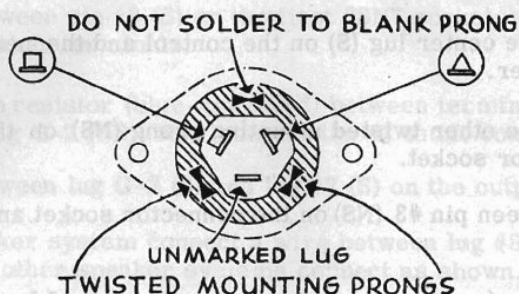

Use amplifier pictorial Step 1

- () Connect the wires from the cable. Cut the wires to the length required and strip the insulation off the end. With the cable supplied with this kit, no special attention need be paid to which wire goes where at this point, but if a cable with two larger conductors is used, these larger wires should be numbers 1 and 2. Connect wire #1 to pin #2 (NS) on the first 5881 socket.
- () Connect wire #2 to pin #7 (NS) on the same socket.
- () Connect wire #3 to the lug G-1 (NS) on the 2-screw speaker terminal strip.
- () Connect wire #4 to the lug C-2 (NS) on the 2-lug terminal strip.
- () Wrap wire #5 which is not used around the long screw that holds the cable clamp. This wire may be considered a spare.
- () Connect wire #6 to pin #6 (S) on the connector socket.
- () Connect wire #7 to pin #7 (S) on the connector socket.
- () Connect wire #8 to pin #8 (S) on the connector socket.
- () Complete the filament wiring. Twist two wires together and on one end connect the one wire to pin #2 (S) and the other to pin #7 (S) on the first 5881 socket.
- () At the other end of the twisted pair of wires connect one wire to pin #2 (NS) and the other wire to pin #7 (NS) on the second 5881 socket.
- () Twist another pair of wires and on one end connect one wire to pin #2 (S) and the other wire to pin #7 (S) on the second 5881 socket.
- () At the other end of this twisted pair connect one wire to pin #7 (NS) and the other wire to pin #8 (NS) on the second 6SN7 socket.
- () In the same manner connect pins #7 (S) and 8 (S) on the second 6SN7 socket with pins #7 (NS), and 8 (NS) on the first 6SN7 socket.

- () Finish the filament wiring by connecting in the same manner pins #7 (S) and 8 (S) on the first 6SN7 socket with pins #1 (S) and 2(S) on the connector socket.
- () Connect a wire between lug G-1 (S) on the speaker terminal strip, and lug #12 (NS) on the output transformer.
- () Connect a wire between lug #12 (S) on the output transformer and the center lug (NS) on the 100 ohm control.
- () Connect a wire between the center lug (S) on the control and the nearest twisted mounting prong (NS) on the condenser.
- () Connect a wire between the other twisted mounting prong (NS) on the filter condenser and pin #3 (NS) on the connector socket.
- () Connect a short wire between pin #3 (NS) on the connector socket and the ground lug (NS) on the phono socket.
- () Connect a 2.2 meg resistor (red-red-green) between the ground lug (S) on the phono socket and pin #1 (NS) on the first 6SN7 socket. (Use sleeving.)
- () Connect a 470 ohm resistor (yellow-purple-brown) between pin #3 (S) on the connector socket, and pin #3 (NS) on the first 6SN7 socket.
- () Connect a 470K resistor (yellow-purple-yellow) between pin #1 (NS) on the second 6SN7 socket, and the nearest twisted mounting prong (NS) on the condenser. (Use sleeving).

Note: One of the twisted mounting prongs has not been pierced, and should not be used as a terminal. This prong should be disregarded.

- () Connect a 390 ohm resistor (orange-white-brown) with one lead through pin #6 to pin #3 (S) on the second 6SN7 socket, and with the other lead to the nearest twisted mounting prong (NS) on the condenser. (Use sleeving). Now solder pin 6.
- () Connect a 470K resistor (yellow-purple-yellow) between pin #4 (NS) on the second 6SN7 socket, and the twisted mounting prong (S) on the condenser. (Use sleeving).

Note: In the following instructions, the term "matched-pair" refers to the two pairs of resistors separately packed and so marked in your kit. These consist of one pair of 22K $\frac{1}{2}$ watt resistors (red-red-orange) and one pair of 47K 2 watt resistors (yellow-purple-orange.) These pairs are carefully matched to each other for equal resistance, and should be used only where indicated to obtain maximum performance from the amplifier.

- () Connect one of the matched-pair 22K resistors (red-red-orange) between pin #6 (NS) on the first 6SN7 socket, and nearest twisting mounting prong (S) on the condenser. (Use sleeving).
- () Connect a wire to pin #4 (S) on the connector socket, and to the \triangle marked lug (NS) on the condenser.
- () Connect a $\frac{1}{2}$ watt 47K resistor (yellow-purple-orange) (do not use one of the large 2 watt matched-pair) with one lead through pin #4 (S) to pin #2 (S) on the first 6SN7 socket, and with the other lead to the \square marked lug (NS) on the condenser. Make sure there is adequate clearance around pin #3 on the socket. (Use sleeving.)
- () Connect a 33K resistor (orange-orange-orange) between the \square marked lug (S) and the \triangle marked lug (NS) on the condenser. (Use sleeving).

- () Connect the other of the matched-pair 22K resistors (red-red-orange) between pin #5 (NS) on the first 6SN7 socket, and the \triangle marked lug (NS) on the condenser. (Use sleeving).
- () Connect a 22K 2 watt resistor (large red-red-orange) between the \triangle marked lug (S) on the condenser, and lug D-2 (NS) on the nearest 2-lug terminal strip. (Use sleeving.)
- () Connect a wire between lug D-2 (NS) and lug C-2 (NS) on the other 2-lug terminal strip.
- () Connect a wire between pin #3 (S) on the first 6SN7 socket, and the 1-lug terminal strip A (S) nearest the speaker terminals.
- () Connect a 6800 ohm resistor (blue-gray-red) between terminal strip A (NS) and the nearest speaker terminal lug G-2 (NS). Now connect the 47 mmf. condenser from A (S) to G-2 (NS).
- () Connect a wire between lug G-2 (S) and lug #7 (S) on the output transformer.
- () For an 8 ohm speaker system connect a wire between lug #8 (S) and lug #11 (S) on the output transformer. For other speaker systems connect as shown.
- () Connect a wire with one end through lug F-2 (S) to lug F-1 (S) and with the other end through lug E-2 (S) to lug E-1 (NS) on the two phone jacks.
- () Connect a .05 MFD tubular condenser between pin #1 (S) on the first 6SN7 socket, and the center lug (S) on the phono socket.

Refer to the amplifier pictorial Step 2.

- () Connect a wire between pin #3 (S) of the first 5881 socket and lug #1 (S) of the output transformer.
- * () Connect a wire between pin #4 (S) of the first 5881 socket and lug #2 (S) of the output transformer.
- () Connect a wire between pin #3 (S) of the second 5881 socket and lug #6 (S) of the output transformer.
- * () Connect a wire between pin #4 (S) of the second 5881 socket and lug #5 (S) of the output transformer.
- () Connect a wire between lug C2 (NS) on the two lug terminal strip, through lug 3 (NS) on the output transformer to lug 4 (S) on the output transformer. Now solder lug 3.
- () Connect a wire between pin #8 (S) on the first 5881 socket and lug F-3 (S) on the corner phone jack.
- () Connect a wire between pin #8 (S) on the second 5881 socket and lug E-3 (S) on the other phone jack.
- () Connect the 250 ohm-10 watt resistor (a fairly large hollow tube marked 250) between lug E-1 (S) on the phone jack, and 1-lug terminal strip B (NS).
- () Connect a 100 ohm resistor (brown-black-brown) between terminal strip B (S) and the lug (NS) nearest the second 5881 socket on the 100 ohm control.

*Read note on page 32 for optional circuit.

- () Connect a 100K resistor (brown-black-yellow) between this lug (S) on the control, and lug D-1 (NS) on a 2-lug terminal strip. (Use sleeving).
- () Connect a 1000 ohm resistor (brown-black-red) between lug D-1 (NS) and pin #5 (S) on the second 5881 socket.
- () Connect a 100 ohm resistor (brown-black-brown) between terminal strip B (S) and the lug (NS) nearest the first 5881 socket on the 100 ohm control.
- () Connect a 100K resistor (brown-black-yellow) between this lug (S) on the control and lug C-1 (NS) on a 2-lug terminal strip. (Use sleeving).
- () Connect a 1000 ohm resistor (brown-black-red) between lug C-1 (NS) and pin 5 (S) on the first 5881 socket.
- () Connect one of the matched-pair 47K-2 watt resistors (large yellow-purple-orange) between lug C-2 (S) on the 2-lug terminal strip, and pin #2 (NS) on the second 6SN7 socket.
- () Connect a .25 MFD (large tubular) condenser between pin #2 (S) on the second 6SN7 socket and lug C-1 (S) on the 2-lug terminal strip. (Use sleeving).
- () Connect the other one of the matched-pair 47K-2 watt resistors (large yellow-purple-orange) between lug D-2 (S) on a 2-lug terminal strip, and pin #5 (NS) on the second 6SN7 socket.
- () Connect a .25 MFD condenser between pin #5 (S) on the second 6SN7 socket, and lug D-1 (S) on the 2-lug terminal strip. (Use sleeving).
- () Connect a .05 MFD condenser between pin #5 (S) on the first 6SN7 socket, and pin #1* (S) on the second 6SN7 socket.
- () Connect another .05 MFD condenser between pin #6 (S) on the first 6SN7 socket, and pin #4 (S) on the second 6SN7 socket.
- () Install the octal plug on the end of the cable. Remove the overall insulation for about $1\frac{1}{2}$ inches. Remove the insulation from each wire for about $\frac{3}{4}$ inch. Slip the plug cap on the cable with the grommet toward the chassis end. Arrange the wires in a circle and slip wire #1 in the hole marked 1, wire #2 in the hole marked 2, and so on. Make sure the wire sticks out beyond the pin, and bend the wire over to keep it from slipping out.

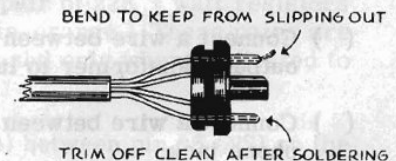
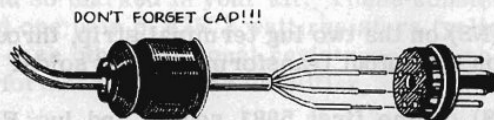
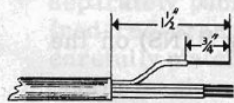

- () Solder the wire in each pin by heating the pin with the soldering iron and letting the solder flow up into the pin. See that no excess solder sticks to the outside of the pin. If necessary reheat the pin and wipe off excess solder with a cloth.
- () Cut off the bent over portions of wire leaving a clean pin.
- () Press the cap over the plug so it snaps into place. When removing this plug from the power supply never pull on the cable. Always use the plug cap for a handle.
- () Check the wiring very carefully against both pictorials and make sure each connection is properly soldered. Shake out any excess solder and loose short pieces of wire.

- () Install the four rubber feet in the bottom plate, and attach to the bottom of the chassis with six #6 sheet metal screws.
- () Install the two 6SN7 GT tubes and the two 5881 tubes in their sockets.

IMPORTANT NOTE

If you purchased the complete Heathkit model W-2 Amplifier, disregard the instructions given in the following section, and proceed with construction of the pre-amplifier in accordance with the instructions starting at the bottom of this page.

If you purchased the main amplifier and power supply only, these units are now ready for test. Before attempting to use the amplifier and power supply, procure from a local source a standard octal connector plug and cap, similar to Amphenol's 86-PM8. This connector is used to make available the following voltages and control circuits for use with auxiliary equipment:

Pins 1 and 2	6.3v. 1.0 amp. AC
Pin 3	Negative plate supply
Pin 4	Positive plate supply (200 v. 10 ma. DC)
Pin 5	Not used
Pins 6 and 8	115v. AC from power line
Pins 6 and 7	Line switch, to control amplifier and AC outlet on power supply chassis.

Before the main amplifier and power supply can be tested, connections should be made to the auxiliary equipment as shown above, or a jumper must be connected between pins 6 and 7 on the connector plug.

- () Connect the auxiliary equipment to the octal plug as indicated above. If desired, the amplifier may be operated without doing this by simply connecting a jumper between pins 6 and 7 on the connector socket.
- () If the signal source (record player or tuner) is not already equipped with a phono plug of the type supplied with this kit, install a phone plug on the output lead of the signal source.
- () Plug the output lead of the signal source into the phono socket on the main amplifier chassis.

Follow the instructions starting with the third paragraph under "Testing the Completed Amplifier" on page 19 of this manual.

PREAMPLIFIER

- () On the narrow subchassis mount the two noval (9-pin) tube sockets, as shown in the sketch, with 3-48 screws and nuts.
- () Mount the condenser mounting wafer on the other side of the chassis with 6-32 screws and nuts. Note the position of the triangular cutout.
- () Install the 5/16 grommet as shown.

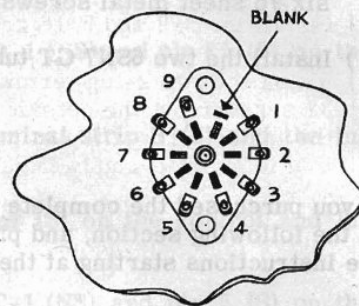
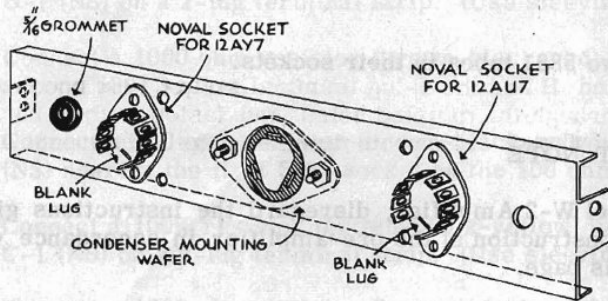

PIN NUMBERING ON NOVAL TUBE SOCKET

- () Mount the 20-20 MFD 450 volt + 20 MFD 25 volt condenser by passing the mounting prongs through the slots in the wafer. After checking to make sure the condenser is properly positioned, and firmly seated against the wafer, twist each of the mounting prongs one-eighth turn with a pair of pliers.

Use the preamplifier pictorial Step 1.

- () Connect a wire with one end through pin #5 (S) to pin #4 (S) on the 12AY7 socket, and with the other end through the hole in the subchassis, along the condenser and back through the next hole in the subchassis through pin #4 (S) to pin #5 (NS) on the 12AU7 socket.
- () Connect a wire with one end to pin #9 (S) on the 12AY7 socket and with the other end through the hole in the subchassis, along the condenser and back through the next hole in the subchassis to pin #9 (NS) on the 12AU7 socket.
- () Connect a wire between the unmarked lug (S) on the condenser and pin #8 (NS) on the 12AU7 socket.
- () Connect a 3300 ohm resistor (orange-orange-red) between pin #3 (S) on the 12AU7 socket and a twisted mounting prong (NS) on the condenser.
- () Connect a 100K resistor (brown-black-yellow) between pin #1 (NS) on the 12AU7 socket, and the \triangle marked lug (NS) on the condenser.
- () Connect a 22K resistor (red-red-orange) between the \triangle marked lug (NS) and the \square marked lug (NS) on the condenser.
- () Connect a 100K resistor (brown-black-yellow) between pin #6 (NS) on the 12AY7 socket, and the \square marked lug (NS) on the condenser.
- () Connect another 100K resistor between pin #1 (NS) on the 12AY7 socket and the \square marked lug (S) on the condenser.
- () Connect a 10 meg resistor (brown-black-blue) with short leads between pin #7 (NS) and pin #8 (NS) on the 12AY7 socket.
- () Connect a .02 MFD tubular condenser between pin #1 (S) and pin #7 (S) on the 12AY7 socket.

Use the preamplifier pictorial Step 2

- () On the main chassis (housing) install the four rubber feet.
- () Install the three phono sockets as shown with 6-32 screws and nuts.

- () Install the 110 volt socket with 6-32 screws and nuts.
- () Install the 3/8 and 5/16 grommets.
- () Mount the two 2-lug terminal strips A and B and the 4-lug terminal strip C, each with a 6-32 screw from the outside of the case through the dimpled holes, and fasten with a nut on the inside. The dimples prevent the screwheads from projecting below the bottom and possibly marring a highly finished table top.
- () Install the long shielded cable. Remove a 1-inch portion of the overall insulation from one end of the cable, exposing the shield braid. Wrap a turn or two of stripped hookup wire around the braid next to the end of the insulation. Solder this wire to the braid.
- () Remove the braid between the soldered connection and the end of the cable.
- () Strip a 1/4 inch of the remaining insulation from the end of the wire, exposing the inner conductor.
- () Cut the hookup wire to a length of about 1 1/4 inches from the soldered connection and strip the insulation off the end.
- () Bend open the small plastic cable clamp and slip it onto the cable at a point about 4 inches from the end, as shown, and place the untrimmed end through the 5/16 grommet from the inside out.

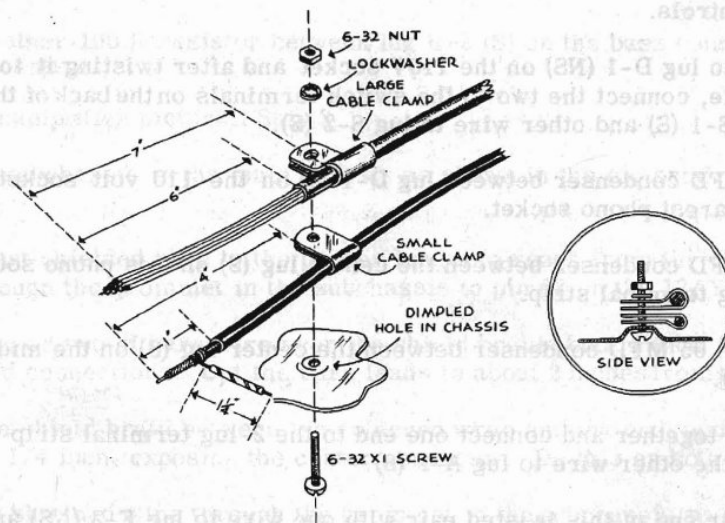

- () Prepare the eight wire cable. Remove a 6 inch portion of the overall insulation from the end. The wire supplied (#22) is adequate for a cable length up to 9 feet. If the installation requires a longer cable between the pre-amplifier and the main amplifier, suitable cable should be obtained locally. Cable with at least two conductors #20 gage is suitable for a 12-foot run. Cable with at least two conductors #18 gage (such as Belden #8448) may be used for distances up to 20 feet. #16 conductors permit operation up to 32 feet. Note that a longer shielded cable will also be required. A single shielded conductor is suitable. As the additional capacity will reduce the high frequency response, a low capacity cable is desirable. For the longer runs, a cable with the lowest capacity should be used (such as Belden #8401). For shorter runs slightly higher capacity per foot may be used (such as Belden #8411). While the high frequency losses may be offset by adjustment of the treble tone control, optimum results will generally be obtained with the cable lengths supplied.

- () Bend open the large plastic cable clamp and slip it on to the cable about 7 inches from the end. Place the untrimmed end through the 3/8 grommet from the inside out.
- () Use a 1 inch long 6-32 screw in the dimpled hole to fasten both cable clamps as shown with a 6-32 nut.
- () Connect some of the wires of the eight wire cable. Cut each wire to the length required. It may be convenient to follow the same color code as used in the main amplifier. Again the larger conductors, if any, should be wires #1 and #2. Connect Wire #3 to lug C-4 (NS) on the 4-lug terminal strip.
- () Connect wire #4 to lug C-1 (NS) on the 4-lug terminal strip.
- () Wrap wire #5, which is not used, around the long screw that holds the cable clamp. This wire may be considered a spare.
- () Connect wire #7 to lug D-1 (NS) on the 110 volt socket.
- () Connect wire #8 to lug D-2 (S) on the 110 volt socket.
- () Mount the switches and controls as shown in the pictorial. Use a control lockwasher between control and chassis. If the pre-amplifier will be used inside a housing, such as a cabinet, determine the shaft length needed, and break off the shafts at the required groove before installing the control. If this unit will not be housed, break off the shaft at the groove nearest the control, and include the control plate between the control nuts and the chassis while mounting the controls.
- () Connect a wire to lug D-1 (NS) on the 110V socket and after twisting it together with wire #6 from the cable, connect the two to the switch terminals on the back of the volume control, one wire to lug S-1 (S) and other wire to lug S-2 (S).
- () Connect a .05 MFD condenser between lug D-1 (S) on the 110 volt socket, and the ground lug (S) on the nearest phono socket.
- () Connect a .05 MFD condenser between the center lug (S) on this phono socket, and lug A-1 (NS) on the 2-lug terminal strip.
- () Connect another .05 MFD condenser between the center lug (S) on the middle phono socket, and lug A-2 (NS).
- () Twist two wires together and connect one end to the 2-lug terminal strip with one wire to lug A-1 (S) and the other wire to lug A-2 (S).
- () Connect the other end of this twisted pair with one wire to lug F-2 (NS) and the other wire to lug F-3 (NS) on the selector switch. Make sure this twisted pair is long enough to be placed against the chassis.
- () Connect a jumper (a short wire) between lug F-2 (S) and lug F-6 (S) on the selector switch.
- () Also connect a jumper between lug F-3 (S) and lug F-7 (S).
- () Connect a wire between lug B-1 (NS) on the 2-lug terminal strip and lug F-4 (NS) on the selector switch.
- () Connect a wire between lug F-4 (S) on the switch and lug G-3 (NS) on the volume control.
- () Connect a wire between lug F-8 (S) on the switch and lug G-1 (S) on the control.

- () Connect a .002 MFD condenser between lug B-2 (NS) on the 2-lug terminal strip and lug E-2 (NS) on the turnover switch.
- () Connect another .002 MFD condenser between lug B-2 (NS) on the strip and lug E-1 (S) on the switch.
- () Connect a .002 MFD condenser between lug C-4 (NS) on the 4-lug strip and lug K-3 (S) on the treble control.
- () Connect a wire between lug C-3 (NS) on the strip, and lug H-2 (NS) on the bass control.
- () Connect a 200 MMF mica condenser between lug C-2 (NS) on the strip, and lug K-1 (S) on the treble control.
- () Connect a 10K resistor (brown-black-orange) between lug C-4 (NS) on the strip, and lug H-3 (NS) on the bass control.
- () Connect a .02 MFD condenser between lug C-3 (NS) on the strip, and lug H-3 (S) on the bass control.
- () Connect a .002 MFD condenser between lug C-3 (S) on the strip, and lug H-1 (NS) on the bass control.
- () Connect a 100K resistor (brown-black-yellow) between lug C-2 (NS) on the strip, and lug H-1 (S) on the bass control.
- () Connect another 100 K resistor between lug H-2 (S) on the bass control, and lug K-2 (NS) on the treble control.

Use the preamplifier pictorial Step 3.

- () Install the subchassis in the main chassis as shown in the pictorial with four 6-32 screws and nuts.
- () Cut the short shielded wire to the proper length to reach from the phono socket nearest the corner through the grommet in the subchassis to pin #2 on the 12AY7 socket.
- () Wrap a turn or two of bare wire over the shield braid about 1 inch from each end. Solder the wrapped connections. Cut the bare leads to about 2 inches from the soldered connection.
- () Remove the shield braid between the soldered wrap and the end, and strip away the insulation for a 1/4 inch, exposing the center conductor. Do this on both ends.
- () Install this shielded wire through the grommet in the subchassis, at one end with the center conductor to the center lug (NS) and the bare shield connection to the ground lug (NS) on the phono socket nearest the corner.
- () On the other end connect the center conductor to pin #2 (S) on the 12AY7 socket, and the bare shield connection to lug B-1 (NS) on the 2-lug terminal strip.
- () Connect a 22K resistor (red-red-orange) between the center lug (S) and the ground lug (S) on the phono socket nearest the corner.
- () Connect a bare wire between pin #8 (S) on the 12AY7 socket, and lug B-1 (NS) on the 2-lug strip.
- () Connect a 2200 ohm resistor (red-red-red) between lug B-1 (S) on the strip and pin #3 (NS) on the 12AY7 socket.

- () Connect a wire between pin #3 (S) on this socket, and lug E-2 (S) on the turnover switch.
- () Connect a 100K resistor (brown-black-yellow) between lug B-2 (S) on the 2 lug terminal strip, and pin #6 (NS) on the 12AY7 socket.
- () Connect a .05 MFD condenser between pin #6 (S) on the 12AY7 socket, and lug F-5 (S) on the selector switch.
- () Connect a wire between lug G-3 (S) on the volume control, and the twisted mounting prong (S) on the filter condenser nearest the 12AY7 tube socket.
- () Connect a wire between the twisted mounting prong (S) on the filter condenser nearest the 12AU7 tube socket, and lug C-4 (NS) on the 4-lug terminal strip.
- () Connect a .05 MFD condenser between pin #1 (S) on the 12AU7 socket, and lug C-2 (S) on the terminal strip.
- () Connect a ^{22K}~~10K~~ resistor (brown-black-orange) between the \triangle marked lug (S) on the filter condenser, and lug C-1 (NS) on the terminal strip.
- () Connect wire #1 from the cable to pin #5 (S) on the 12AU7 socket.
- () Connect wire #2 from the cable to pin #9 (S) on the 12AU7 socket.
- () Connect a 2200 ohm resistor (red-red-red) between pin #8 (S) on the 12AU7 socket, and lug C-4 (NS) on the 4-lug terminal strip.
- () Connect a wire between pin #7 (S) on the 12AU7 socket, and lug K-2 (S) on the treble control.
- () Connect a 22K resistor (red-red-orange) between lug C-1 (S) on the terminal strip and pin #6 (NS) on the 12AU7 socket. *the \triangle lug (S) on the filter condenser*
- () Connect a wire between pin #2 (S) on the 12AU7 socket, and lug G-2 (S) on the volume control.
- () Place the end of the shielded cable through the hole in the subchassis and connect the center conductor to pin #6 (S) on the 12AU7 socket, and connect the wire that is soldered to the shield to lug C-4 (S) on the 4-lug terminal strip.
- () Install the phono plug on the other end of the shielded cable. Remove both the overall insulation and the shield braid for a distance of slightly over one inch. Then remove 3/4 inch of the remaining insulation thus exposing the center conductor. Slip the wire through the plug and solder. No connection is made between the shield and the plug, as this circuit is completed by wire #3 in the other cable. Note: When removing this plug from the amplifier chassis, always pull on the plug (or use a screw driver as a lever) - never pull on the wire.
- () Install the octal plug on the end of the other cable. Follow the procedure described in the last steps of the Amplifier Section.
- () Check the wiring very carefully against the pictorial diagrams and make sure each connection is properly soldered. See that no accidental short circuits exist, such as between the bare leads on resistors and condensers, and adjacent lugs on chassis parts. Make sure that the lugs on the controls and switches will not be shorted out by the cover when it is installed. Thoroughly shake out all loose wire ends and solder.

- () Install the 12AU7 tube in the socket nearest the cable clamps and the 12AY7 tube in the other socket. Be careful when installing miniature tubes - make sure the tube pins are straight and that there is no solder on the socket parts that might prevent insertion. It is possible to damage the tube by exerting excessive pressure and such damage is not covered by any warranty.
- () Install the cover with six #6 sheet metal screws.

TESTING THE COMPLETED AMPLIFIER

Now that the three units are completed, their operation should be checked, and the output stage should be adjusted for equal currents in the 5881 tubes.

Plug the two cables from the preamplifier into the proper sockets on the main amplifier chassis. Plug the cable from the main amplifier into the connector socket on the power supply chassis.

Connect the loudspeaker leads to the speaker terminals on the main amplifier chassis.

If the following testing components are not on hand, they can probably be borrowed from a friend or a local radio service man can make the adjustment in a few minutes. If desired, the essential parts can be obtained locally or from one of the large mail-order radio parts companies for less than \$2.00. Their possession in case of tube replacement or balance checks after prolonged use may be well worth the small outlay. A pocket tester, such as the Heathkit Handitester would be more convenient for a multitude of tests in case of operating difficulties, and should prove of value to the technically inclined constructor.

Connect a DC milliammeter with a range of not less than 60 milliamperes full scale (preferably 0-100 milliamperes) to a phone plug. Connect the positive (+) terminal of the meter to the center connection of the phone plug (tip) and the other meter terminal to the outer connection of the phone plug (sleeve).

Plug the line cord from the power supply into a 105-125 volt 50/60 cycle AC (alternating current) outlet. Caution: Do not plug into a DC (direct current) outlet, such as is found in some of the older districts of the bigger cities. DC will cause the fuse to break the circuit and prevent damage. This amplifier will not operate on DC or 25 cycle AC, and replacing the fuse will be to no avail.

Turn the amplifier on by turning the volume control on the preamplifier clockwise. Observe the filaments in the tubes on the amplifier and power supply. If they light up the filament circuits are functioning correctly.

Set the selector switch to MAG (magnetic pickup) and turn the volume control and bass control clockwise. The speaker should now produce some hum (a low rumbling sound). This indicates that the amplifier circuits appear to be functioning normally.

Turn the volume control counterclockwise without turning the amplifier off. Insert the phone plug that is connected to the meter into one of the phone jacks on the amplifier. The meter should indicate between 40 and 60 milliamperes. Note the reading and insert the plug into the other jack. Adjust the control between the 5881 tubes with a screwdriver until both readings are alike.

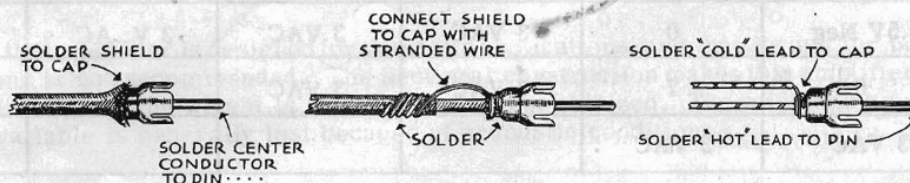

If the signal source (record player or tuner) is not already equipped with a phono plug of the type supplied with this kit, install a phono plug on the output lead of the signal source as shown.

Plug the signal source into the appropriate phono socket on the preamplifier, that is the socket nearest the corner should be used for magnetic type (G.E. variable reluctance, Pickering, Audax) phono pickups only. The other two (low gain) sockets should be used with AM or FM tuners or crystal phono pickups.

Tape reproducers generally have their own compensating amplifier built-in, and their output is suitable for operation through either one of the two low gain channels.

IN CASE OF DIFFICULTY

If the initial tests do not produce the desired results, proceed as follows:

1. Make sure that all the tubes light up properly. Make sure the tubes are in their proper sockets. Test the tubes.
2. Have a friend check the wiring against the pictorials. Mistakes in wiring are much easier found by another person.
3. Check the operating voltages with a meter. All measurements are made between tube pins and chassis. The voltages should check within 20% of the values listed below, if a vacuum tube voltmeter (VTVM) with 11 megohms input resistance is used. With a voltohmmeter (VOM) of 1000 or 20,000 ohms per volt sensitivity some readings may be considerably less. If a reading is found to differ appreciably from the tabulated value, check into that part of the circuit to locate the source of the trouble. This can be done, for instance, by checking the resistance of the resistors, and testing the condensers for opens or shorts.

Voltage Table Socket Pin to Chassis

Pin No.	12AY7	12AU7	First 6SN7	Second 6SN7	Either 5881	5V4G
1	90 ⁴⁸	75 ⁴⁸	0 ⁰	0 ⁰	0	
2	0	0	45 ⁸⁰	175 ¹⁶⁰	2.3 V on both 3 V. AC	440
3	1.5 ^{1.2}	3.5 ^{2.6}	1 ^{1.3}	5.5 ^{4.3}	420 415 ⁴²⁰	
4	3 VAC	3 VAC	45 ⁸⁰	0	430 420 ⁴³⁰ (lead)	375 VAC
5	3 VAC	3 VAC	160 ²²⁵	175 ¹⁶⁵	left 0 to 10 right 28	
6	60 ⁴⁶	160 ¹⁰⁰	50 ^{85V}	5.5 ^{4.3}	0	375 VAC
7	0.5V Neg ⁰	0 ⁰	3 VAC ^{2.6}	3 VAC ^{2.6}	2.3 V on both 3 V. AC	
8	0 ¹¹	7 ^{4.4}	3 VAC ^{2.6}	3 VAC ^{2.6}	36 ^{65 on both}	440
9	3 VAC	3 VAC				

4. If the amplifier oscillates and produces a loud squeal, or motorboats and makes a putt-putt sound, check for improper positioning of parts and wiring (known as lead-dress) and poor solder connections to ground (chassis) or filter condensers. (Note: Speaker leads placed close to the unshielded portions of the input leads will readily provoke oscillation, and acoustic feedback from the speaker back to the turntable and pickup may result in a roar or howl at maximum settings of the volume control.)
5. If a part is believed to be, or actually found to be, faulty, please write us promptly and we will advise you.
6. Should the procedure as outlined fail to bring the desired results, write to the Heath Company, describing the difficulties by giving all possible information, such as sounds produced, meter readings obtained, and all other pertinent data available. We will attempt to analyze your trouble and advise you accordingly.

IN ALL CORRESPONDENCE, REFER TO THIS KIT AS THE MODEL W-2 AMPLIFIER. Failure to mention this model number will make it difficult to determine which of the many models produced, both at present and in the past, you are referring to.

OPERATION

The operation of the amplifier is controlled by the knobs on the preamplifier unit.

The center knob marked "Volume" turns the amplifier on and controls the volume.

The control knob marked "Bass" controls the bass response and permits the low notes to be attenuated (reduced) or accentuated.

The control knob marked "Treble" controls the high notes in the same manner.

The knob marked "Selector" permits the selection of any one of the three input sockets.

The knob marked "Turn-over" affects the response through the magnetic phono channel only. It permits proper compensation for the type of record used.

The source of signal is connected to one of the input sockets on the rear of the preamplifier case.

Magnetic phono pickups should be connected to the socket nearest the corner.

All other sources such as AM or FM tuners, crystal phono pickups and suitable wire or tape reproducers should be connected to either of the remaining sockets.

The 110 volt socket on the power supply is intended for operation of speakers requiring 110 volts AC for the speaker field supply.

The 110 volt socket on the preamplifier is intended for tuners or other input sources requiring 110 volts AC for operation.

The on-off switch on the preamplifier controls the power obtained through these 110 volt sockets.

Note that this amplifier is designed for domestic applications, and that its use for public address applications is not recommended. The sectional construction makes this amplifier inconvenient to move around and the weight is high for the output obtained. The outstanding quality of reproduction available is generally lost because of acoustic conditions.

APPLICATION AND INSTALLATION

The W-2 amplifier is designed for high quality domestic sound applications. Such applications require additional components, like a suitable reproducer system, and one or more sources of signal. In order to make the fullest use of the quality obtainable from the amplifier, the other components should also be of as high a quality as possible, as the weakest link in the chain will determine the ultimate performance level.

The choice of reproducer depends primarily upon the space available. Excellent results may be obtained from speakers of various sizes, ranging all the way from an 8 inch to 15 inch cone diameter. The larger speakers generally require a housing or enclosure of greater dimensions. The type of reproducer is also affected by individual taste, and generally both the multiple speakers with electrical or mechanical crossover networks, as well as the high grade single cone reproducers, are serving satisfied listeners. A further discussion of the problem of speaker selection is beyond the scope of this manual.

The main amplifier lends itself to operation directly from signal sources that are equipped with volume and tone controls such as some AM and FM tuners, tape or wire reproducers, or record players.

For signal sources without volume and tone controls such as the simple tuners or record players, the use of the preamplifier is recommended.

The installation depends on the individual requirements. Generally the amplifier and power supply will be installed in a cabinet or other enclosure. The preamplifier may be placed under or near the record player or tuner, out in the open, or installed in a cabinet. The shaft length required will depend upon the installation. Note: This amplifier system consumes 120 watts of power, which is converted to heat. This heat will produce a temperature rise in the cabinet equal to the effect of two standard 60 watt light bulbs burning in the same space. Adequate ventilation should be provided to permit the heat to escape, thus keeping the temperature from rising too high. High temperature operation may adversely affect the life of some of the components in the amplifier, and may also damage the finish of the cabinet.

We do not recommend installation of amplifier and power supply inside the speaker housing. Most types of speaker housings do not permit adequate ventilation and the resulting high temperatures may ruin a good speaker.

When planning the actual installation, keep the following points in mind:

- a. Select the location of the speaker so that it is aimed at the listeners.
- b. Provide adequate ventilation for the amplifier and power supply.
- c. Locate the preamplifier as close to the source and the main amplifier as conveniently possible, to reduce high frequency losses in the shielded cables.
- d. Keep the preamplifier and source separated from the speaker to prevent acoustic feedback.

USING THE PREAMPLIFIER WITH OTHER AMPLIFIERS

The WA-P1 preamplifier may be used with other types and makes of amplifiers not equipped with adequate tone controls and/or compensated magnetic pickup preamplifier.

The operating voltages may generally be obtained from the main amplifier with which it is to be used. Connect leads #1 and 2 to the 6.3 volt filament circuit in the amplifier. Connect lead #3 to the chassis and lead #4 to a positive lug on a filter condenser in the amplifier that provides a well filtered voltage of between 150 and 300 volts. If the power circuits of the amplifier lend themselves to switching in the preamplifier, leads #6, 7 and 8 may be connected with #6 going directly to one lead of the line cord, #7 lead connecting to one lead of the power transformer

primary (117 volt) winding, and lead #8 (common) connecting to the other lead of the power transformer and also to the other lead of the line cord.

The output of the preamplifier (thin cable) is connected to the input of the amplifier. **NOTE:** The output of the preamplifier contains the plate voltage of the last stage. The input of the main amplifier must therefore contain a blocking condenser between the input socket and the grid circuit of the first stage. If such a condenser is not already an inherent part of the main amplifier, it should be installed in the amplifier rather than added in the preamplifier between output plate and output cable.

SERVICE

In event continued operational difficulties of the completed instrument are experienced, may we remind you that the Heath Company has provided a technical consultation service. Every effort will be made to assist you through correspondence. We emphasize that in all correspondence this instrument should be referred to as the Model W-2 AMPLIFIER

The facilities of the Heath Company Service Department are also available. Your instrument may be returned for inspection and repair for a service charge of \$5.00 plus the cost of any additional material that may be required. **THIS SERVICE POLICY APPLIES ONLY TO COMPLETED INSTRUMENTS CONSTRUCTED IN ACCORDANCE WITH THE INSTRUCTIONS AS STATED IN THE MANUAL.** Instruments that are not completed or instruments that are modified will not be accepted for repair. Instruments showing evidence of acid core solder or paste fluxes will be returned NOT repaired.

The Heath Company is willing to offer its utmost cooperation to assist you in obtaining proper operation of your instrument. The repair service is available until one year from the date of purchase.

NOTE: Before returning this unit, be sure all parts are securely mounted. Attach a tag to the instrument giving name, address and trouble experienced. Pack in a rugged container, preferably wood, using at least three inches of shredded newspaper or excelsior on all sides. Do not ship in original carton only as this carton is not considered adequate for safe shipment of the completed instrument. Ship by prepaid express, if possible. Return shipment will be made by express collect. Note that a carrier cannot be held liable for damage in transit if packing, in HIS opinion, is insufficient.

Prices are subject to change without notice. The Heath Company reserves the right to change the design without incurring liability for equipment previously supplied.

WARRANTY

The Heath Company limits its warranty on any part supplied with any Heathkit (except tubes, meters, and rectifiers, where the original manufacturer's guarantee only applies) to the replacement within three (3) months of said part which, when returned with prior permission, postpaid, was, in the judgment of the Heath Company, defective at the time of sale.

The assembler is urged to follow the instructions exactly as provided. The Heath Company assumes no responsibility nor liability for any damages or injuries sustained in the assembly of the device or in the operation of the completed instrument.

WA-P1 PREAMPLIFIER PARTS LIST

Part No.	Parts Per Kit	Description	Part No.	Parts Per Kit	Description
Resistors:			Tubes:		
✓ 1-44	2	2200 ohms	✓ 411-25	1	12AU7
✓ 1-14	1	3300 ohms	✓ 411-37	1	12AY7
<i>short</i> ✓ 1-20	2	10K ohms	Sheet Metal Parts:		
✓ 1-22	3	22K ohms (<i>extra</i>)	✓ 200-M23	1	Chassis
✓ 1-26	6	100K ohms	✓ 200-M24	1	Sub chassis
✓ 1-40	1	10 megohms	✓ 205-M9	1	Control Plate
Condensers:			✓ 205-M10	1	Cover Plate
✓ 20-3	1	200MMF	Wire:		
✓ 23-18	4	.002 MFD	✓ 340-2	1	length bare wire
✓ 23-8	2	.02 MFD	✓ 342-1	1	length shielded wire
✓ 23-10	5	.05 MFD	✓ 343-2	1	length shielded cable
✓ 25-6	1	20-20 MFD 450V+20 MFD 25V	✓ 344-1	1	roll hookup wire
Controls - Switches - Knobs:			✓ 346-1	1	length spaghetti
✓ 10-22	2	1 megohm lin. controls	✓ 347-1	1	length cable
✓ 19-7	1	1 megohm aud. control w. sw.	Hardware:		
✓ 63-35	1	SPST rotary switch	✓ 73-1	1	3/8 grommet
✓ 63-36	1	3 position rotary switch	✓ 73-4	2	5/16 grommets
✓ 462-1	5	pointer knobs	✓ 207-3	1	1/8 cable clamp
Terminal Strips - Sockets - Plugs - Wafer:			✓ 207-5	1	3/16 cable clamp
✓ 431-2	2	2 lug terminal strip	✓ 250-2	4	3-48 screws
✓ 431-5	1	4 lug terminal strip	✓ 250-8	6	#6 sheet metal screws
✓ 434-16	2	noval sockets	✓ 250-9	17	6-32x3/8 screws
✓ 434-18	3	phono sockets	✓ 250-13	1	6-32x1 screw
✓ 434-20	1	110V socket	✓ 252-1	4	3-48 nuts
✓ 438-4	3	phono plugs	✓ 252-3	18	6-32 nuts
✓ 438-6	1	octal plug	✓ 252-7	5	control nuts
✓ 440-1	1	octal plug cap	✓ 254-1	18	#6 lockwashers
✓ 481-4	1	3 prong ins. mtg. wafer	✓ 254-4	5	control lockwashers
			✓ 261-1	4	rubber feet

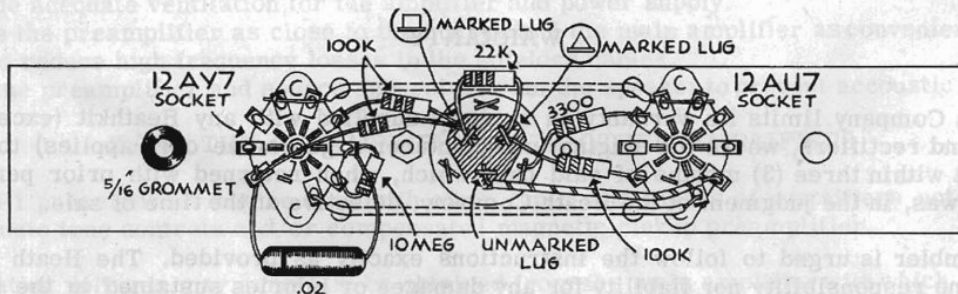

STEP I.

W-2M AMPLIFIER PARTS LIST

Part No.	Parts Per Kit	Description	Part No.	Parts Per Kit	Description
Resistors - Control:			Terminal Strips—wafers:		
✓1-3	2	100 ohms (2 extra)	✓431-1	3	1 lug terminal strips
✓1-48	1	390 ohms	✓431-2	2	2-lug terminal strips
✓1-6	1	470 ohms	✓431-6	1	2-screw terminal strip
✓1-9	2	1000 ohms	✓481-4	3	3-prong ins. mtg. wafers
✓1-19	1	6800 ohms			
✓1-22	2	22K ohms (Matched)	Sheet Metal Parts:		
✓1-24	1	33K ohms	✓200-M21	1	Power supply chassis
✓1-25	1	47K ohms	✓200-M22	1	Amplifier chassis
✓1-26	2	100K ohms	✓205-M8	2	Bottom plates
✓1-33	2	470K ohms			
✓1-37	1	2.2 Meg.	Wire:		
✓1-11B	1	22K ohms-2 Watt	✓89-1	1	Line Cord
✓1-10B	2	47K ohms-2 Watt (Matched)	✓344-1	1	Roll hookup wire
✓3-2J	1	250 ohms-10 Watt	✓346-1	1	Length spaghetti
✓11-1	1	100 ohms control	✓347-1	1	Length cable
Condensers:			Choke—Transformers:		
✓20-1	1	47 MMF	✓46-6	1	Filter choke
✓23-10	3	.05 MFD	✓51-8	1	Output transformer
✓23-24	2	.25 MFD	✓54-13	1	Power transformer
✓25-6	1	20-20 MFD 450V+20 MFD 25V			
✓25-16	2	20 MFD-350V	Hardware:		
✓25-17	2	50 MFD-350V	✓73-1	3	3/8 grommets
Tubes:			✓73-2	2	3/4 grommets
✓411-15	2	6SN7GT	✓207-5	1	3/16 cable clamp
✓411-45	2	5881	✓250-8	12	#6 sheet metal screws
✓411-35	1	5V4G	✓250-9	19	6-32 x 3/8 screws
Sockets-Jacks-Plugs-Fuse:			✓250-13	1	6-32 x 1 screw
✓421-2	1	Fuse	✓250-17	12	8-32 x 1/4 screws
✓423-1	1	Fuse holder	✓252-3	20	6-32 nuts
✓434-2	2	Octal saddle sockets	✓252-4	8	8-32 nuts
✓434-4	5	Octal ring sockets	✓252-7	3	control nuts
✓434-18	1	Phono socket	✓253-10	3	nickel washers
✓434-20	1	110-V socket	✓253-15	2	3/8 fibre flat washers
✓436-4	2	Phone jacks	✓253-16	2	3/8 fibre shoulder washers
✓438-4	1	Phono plug	✓254-1	20	#6 lockwashers
✓438-6	1	Octal plug	✓254-2	12	#8 lockwashers
✓440-1	1	Octal plug cap	✓254-4	1	control lockwasher
			✓261-1	8	rubber feet
			✓435-1	5	tube socket rings

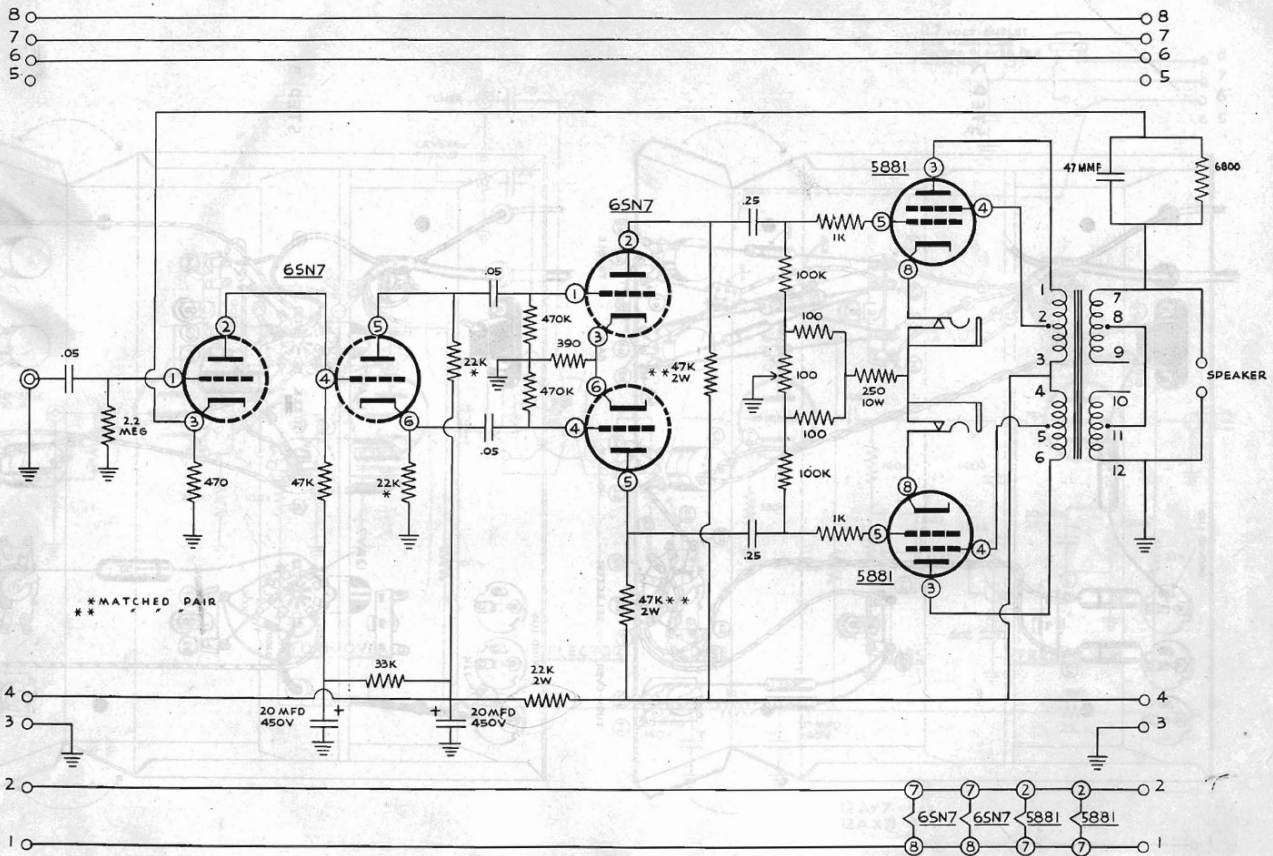

Heathkit MODEL W-2
AMPLIFIER CIRCUIT DIAGRAM

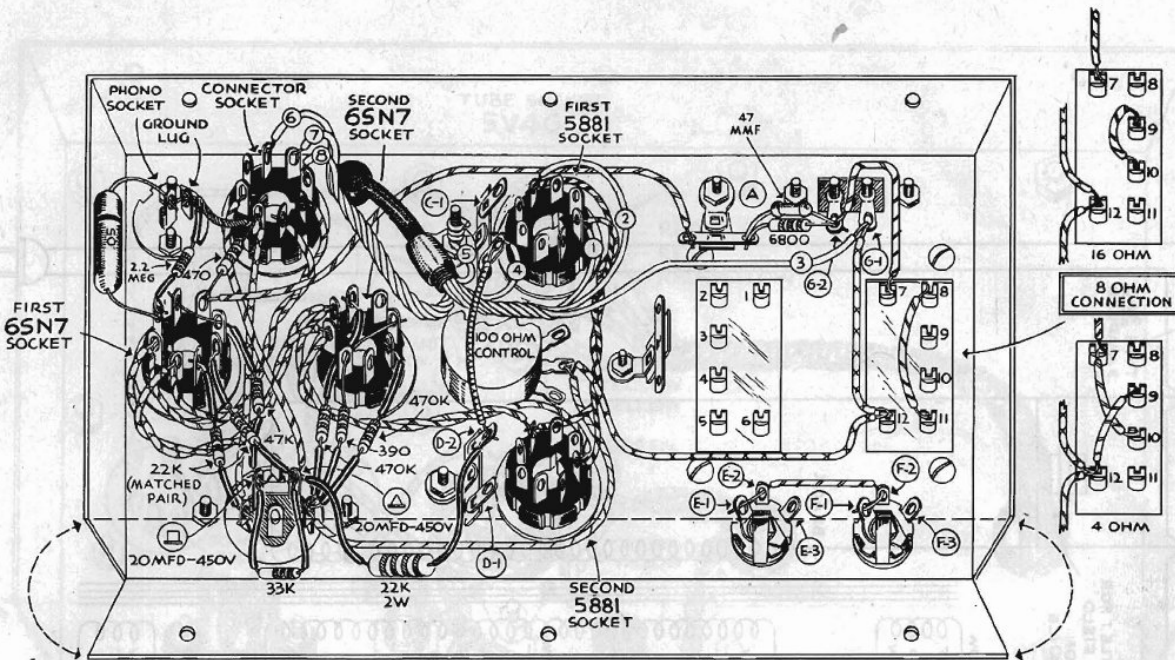

AMPLIFIER PICTORIAL STEP 1

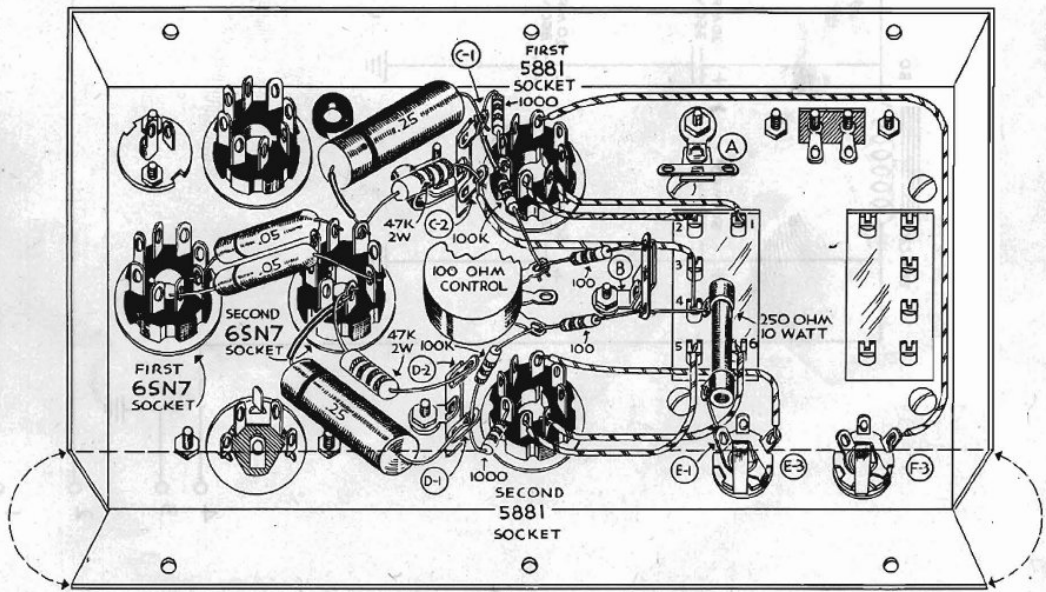

AMPLIFIER PICTORIAL STEP 2

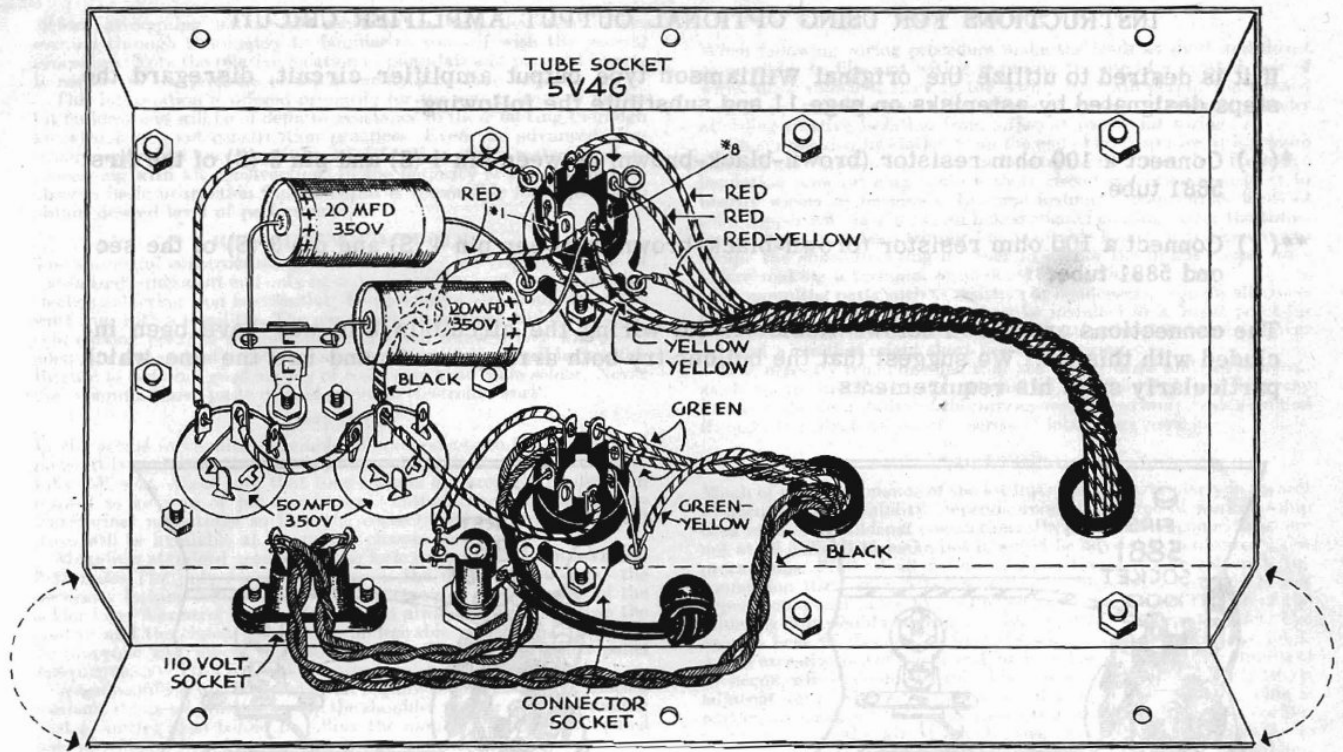

POWER SUPPLY PICTORIAL

INSTRUCTIONS FOR USING OPTIONAL OUTPUT AMPLIFIER CIRCUIT

If it is desired to utilize the original Williamson type output amplifier circuit, disregard the steps designated by asterisks on page 11 and substitute the following:

- * () Connect a 100 ohm resistor (brown-black-brown) between pin 4 (S) and pin 3 (S) of the first 5881 tube.
- ** () Connect a 100 ohm resistor (brown-black-brown) between pin 4 (S) and pin 3 (S) of the second 5881 tube.

The connections are shown below. Resistors for wiring the circuit in this way have been included with this kit. We suggest that the builder try both arrangements and use the one which particularly suits his requirements.

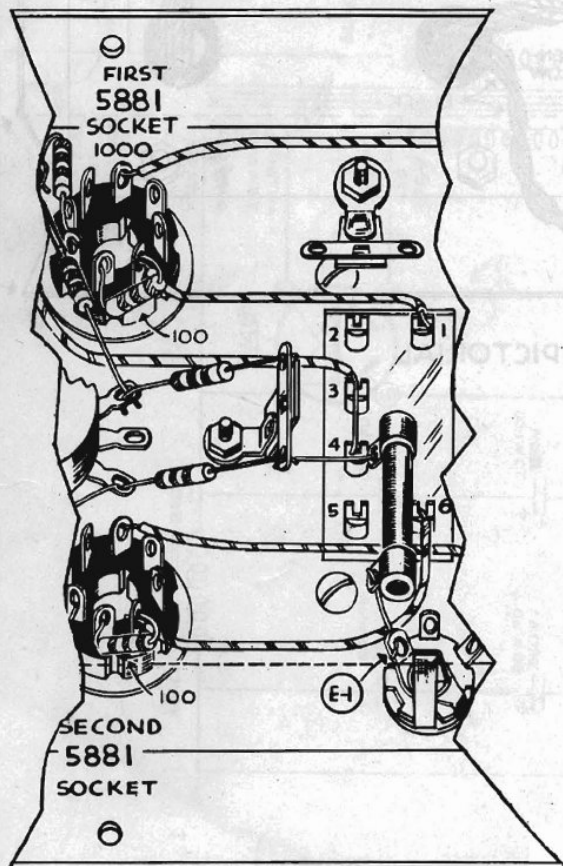

Original Williamson connections.

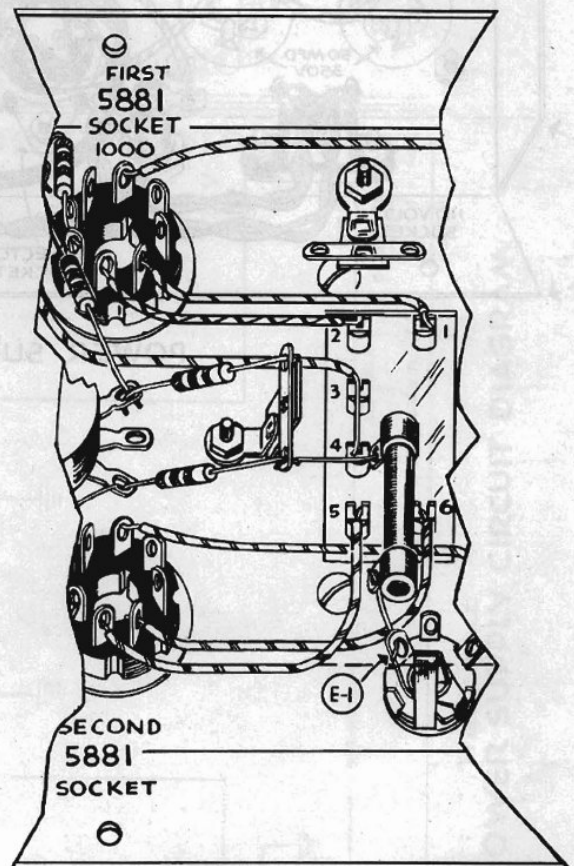

"Gilding the Lily" connections.

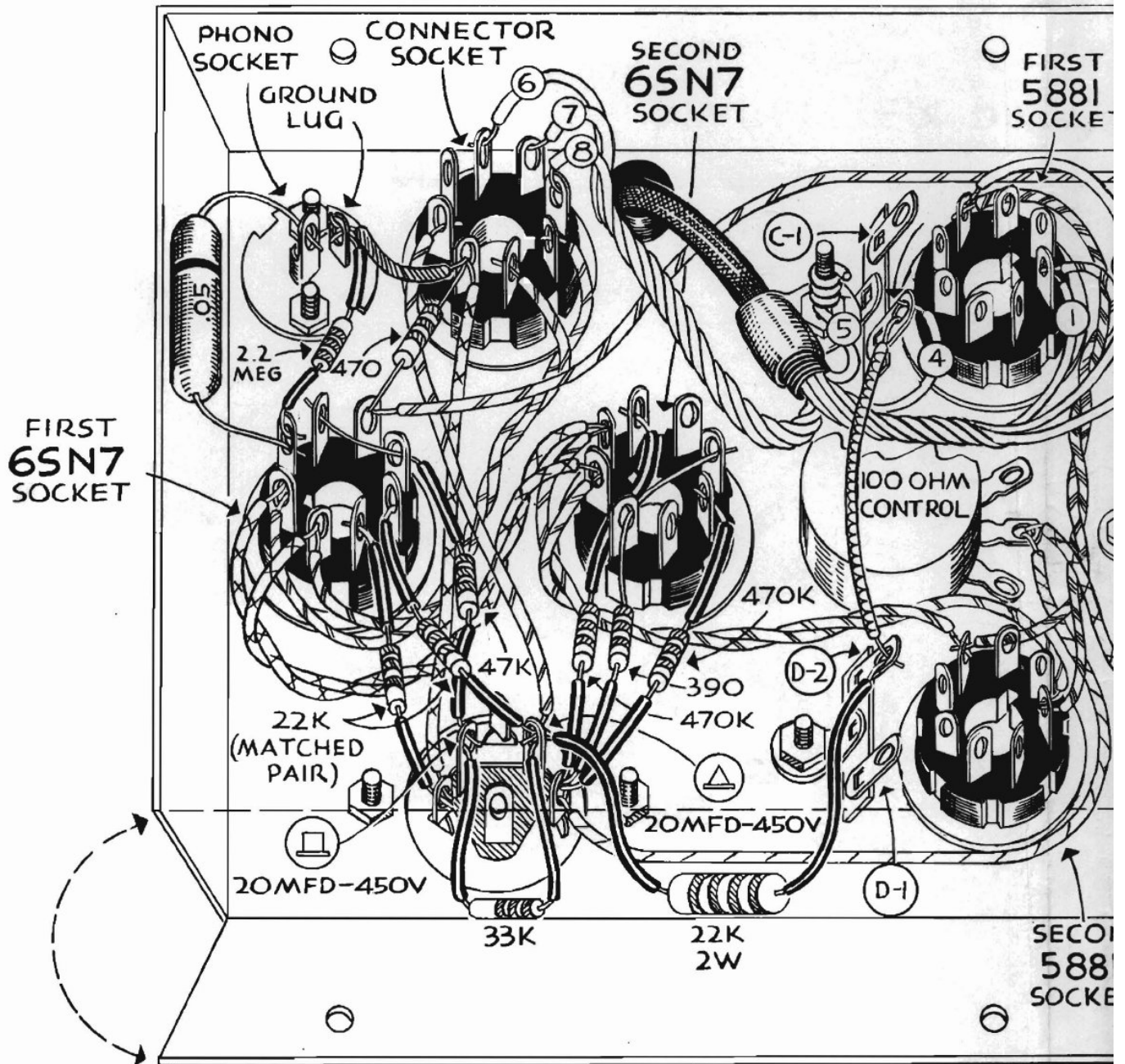

cable
 leads
 Black 1
 Brown 2
 Red 3
 Orange 4
 Yellow 5
 Green 6
 Blue 7
 White 8

AMPLIFIER PICTORIAL

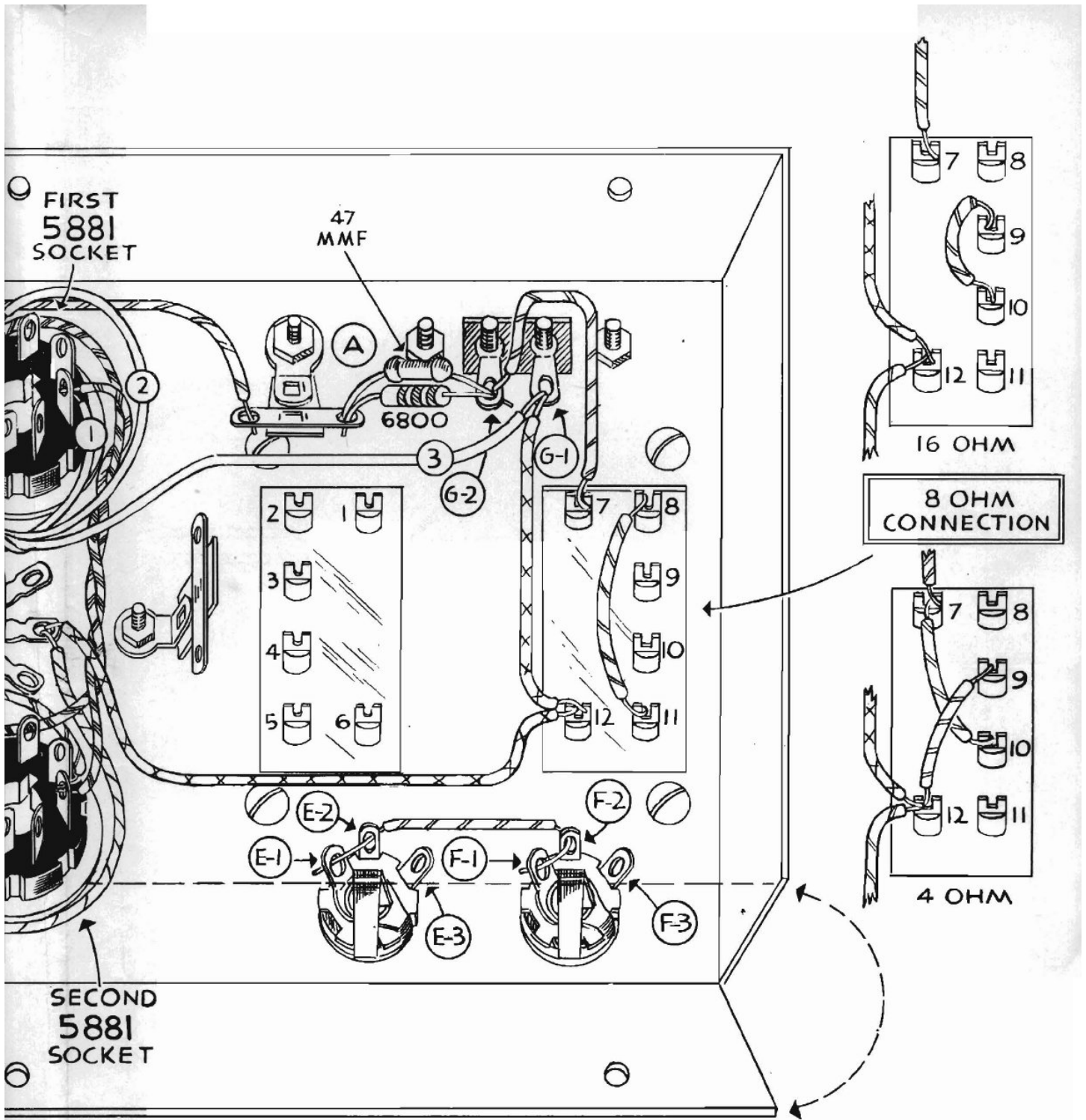

PROCEDURAL STEP 1

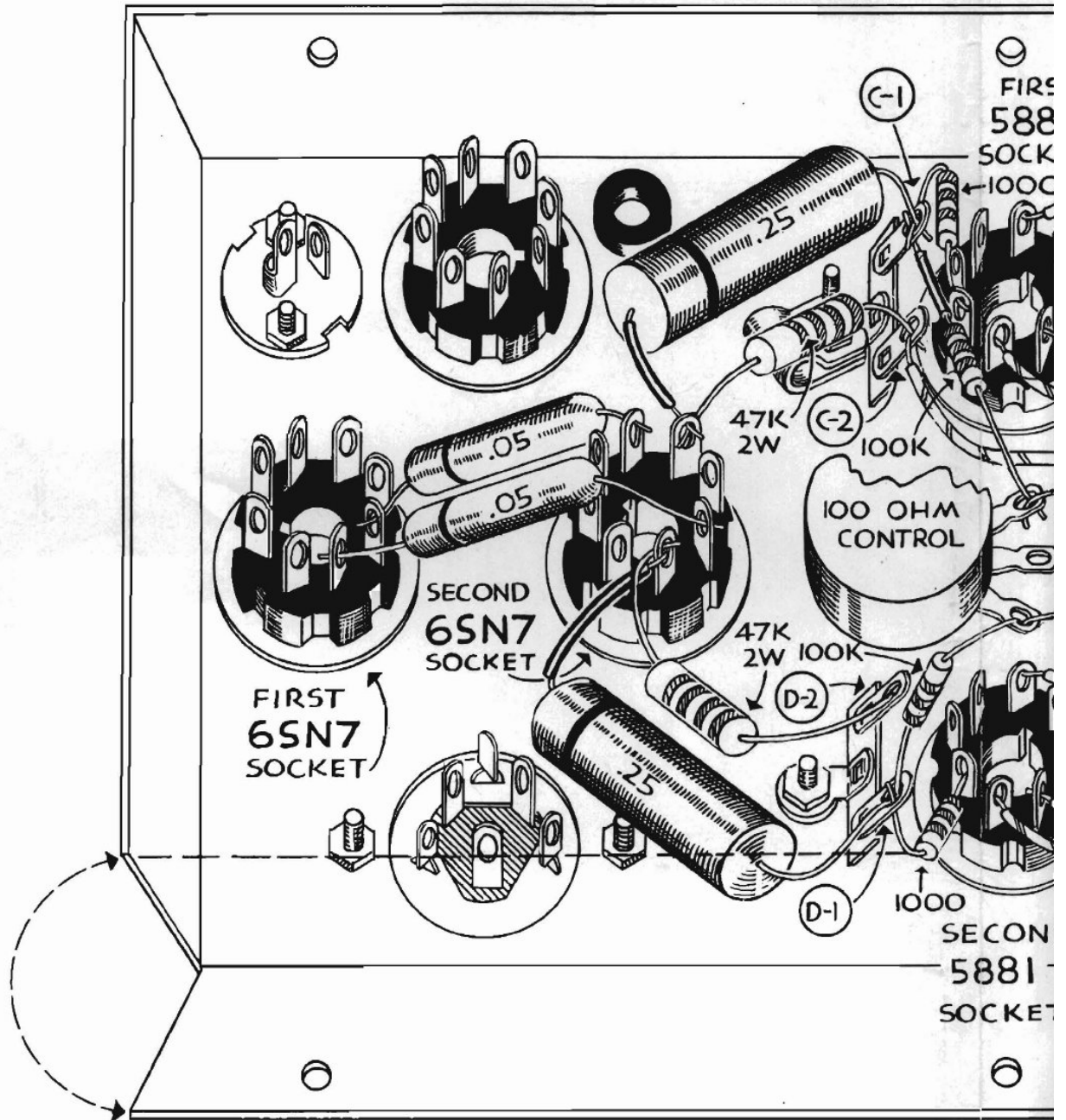

AMPLIFIER PICTOR

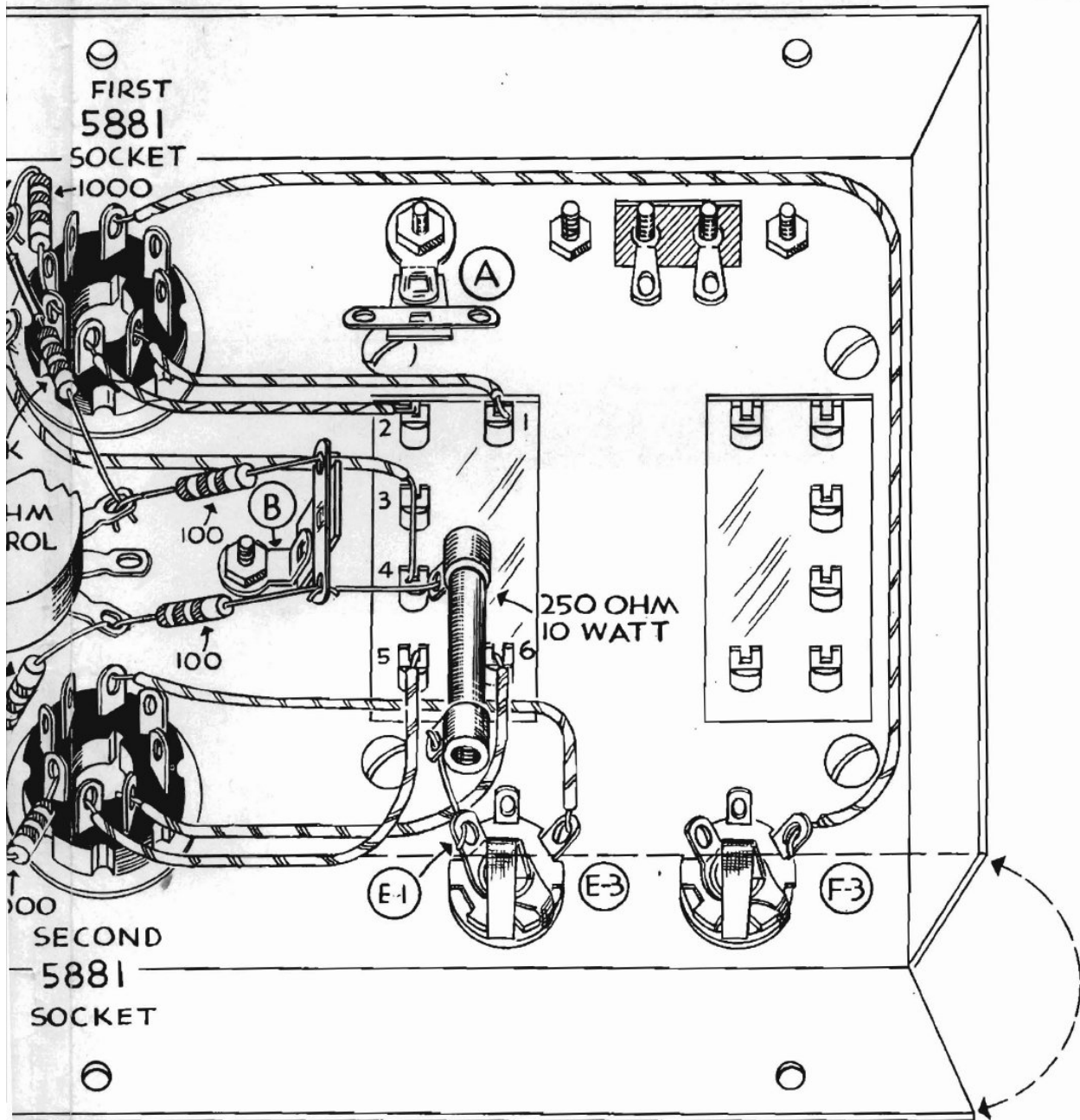

PICTORIAL STEP 2

This extra large scale copy is furnished to facilitate construction. It is suggested that this copy be fastened to a wall above the working area in order to provide a ready reference.

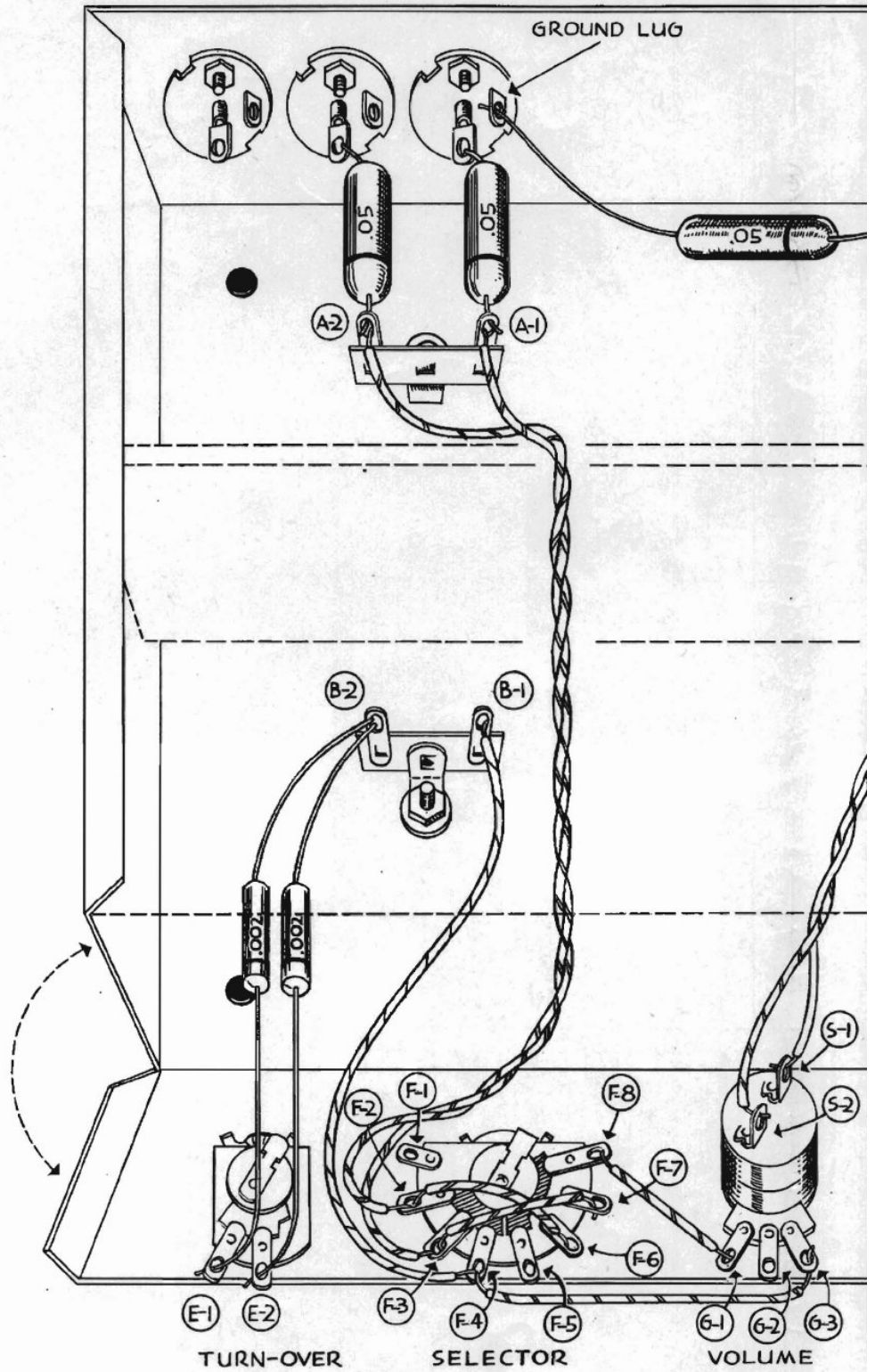

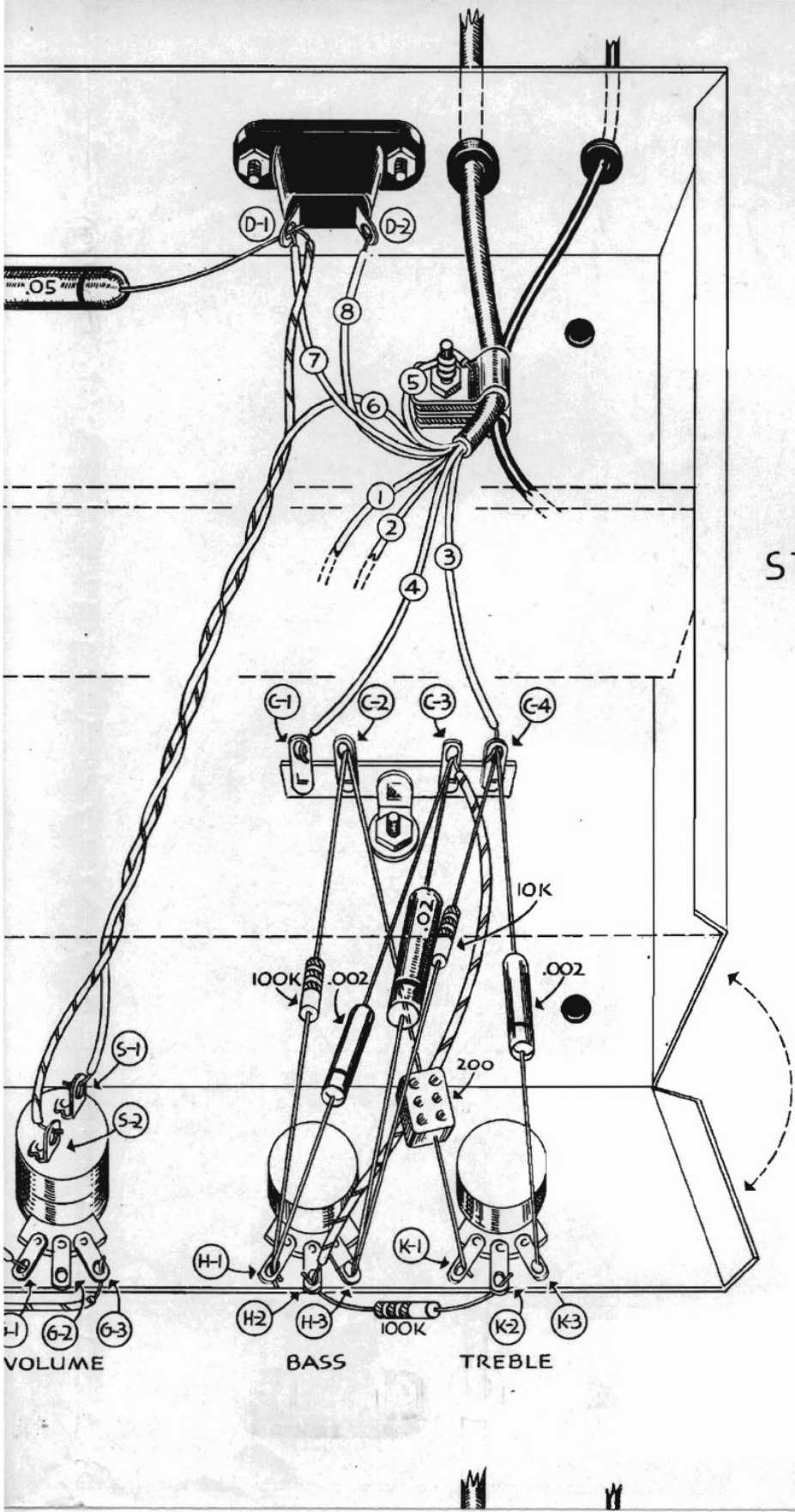

STEP 2.

VOLUME

BASS

TREBLE

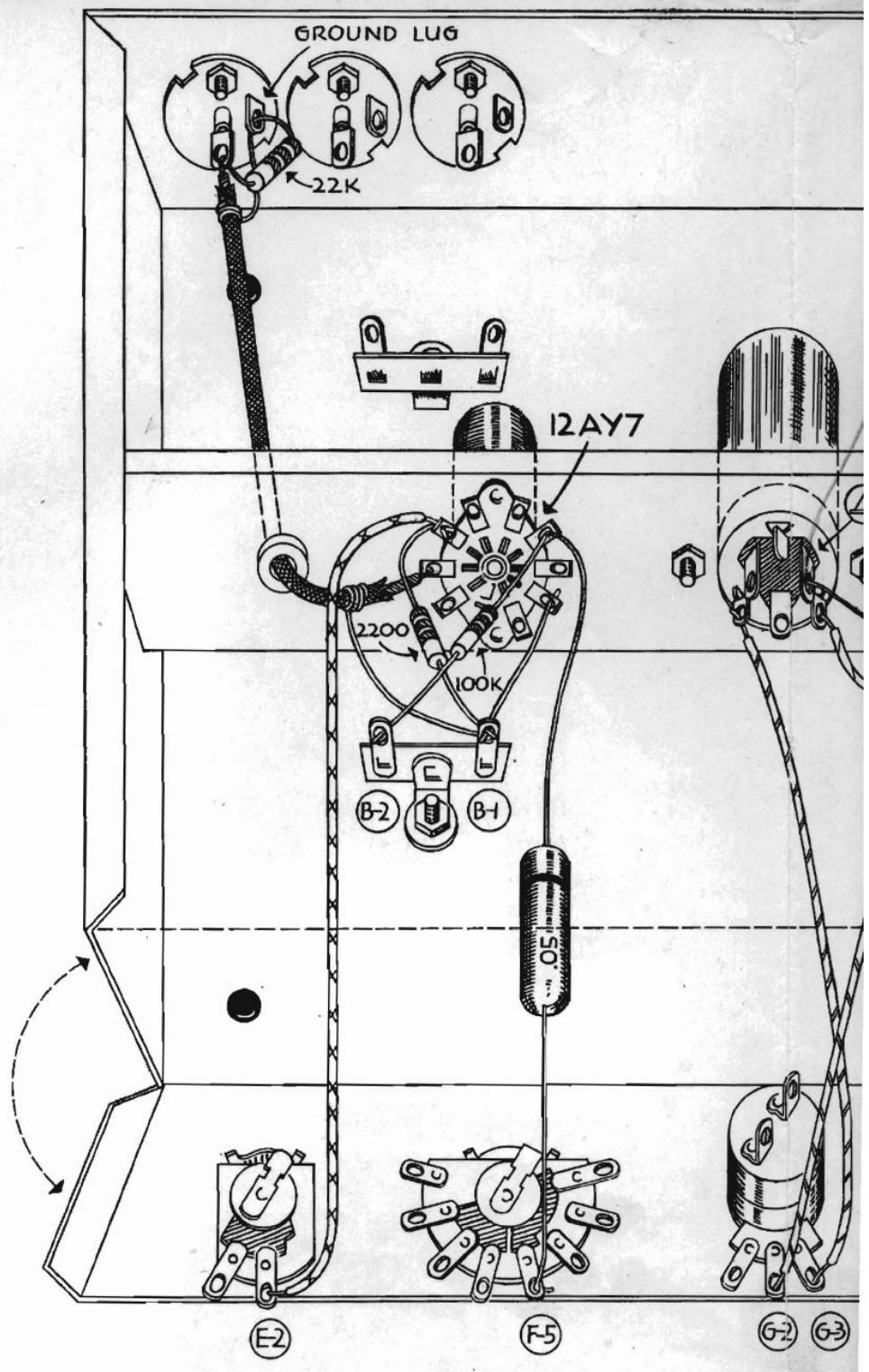

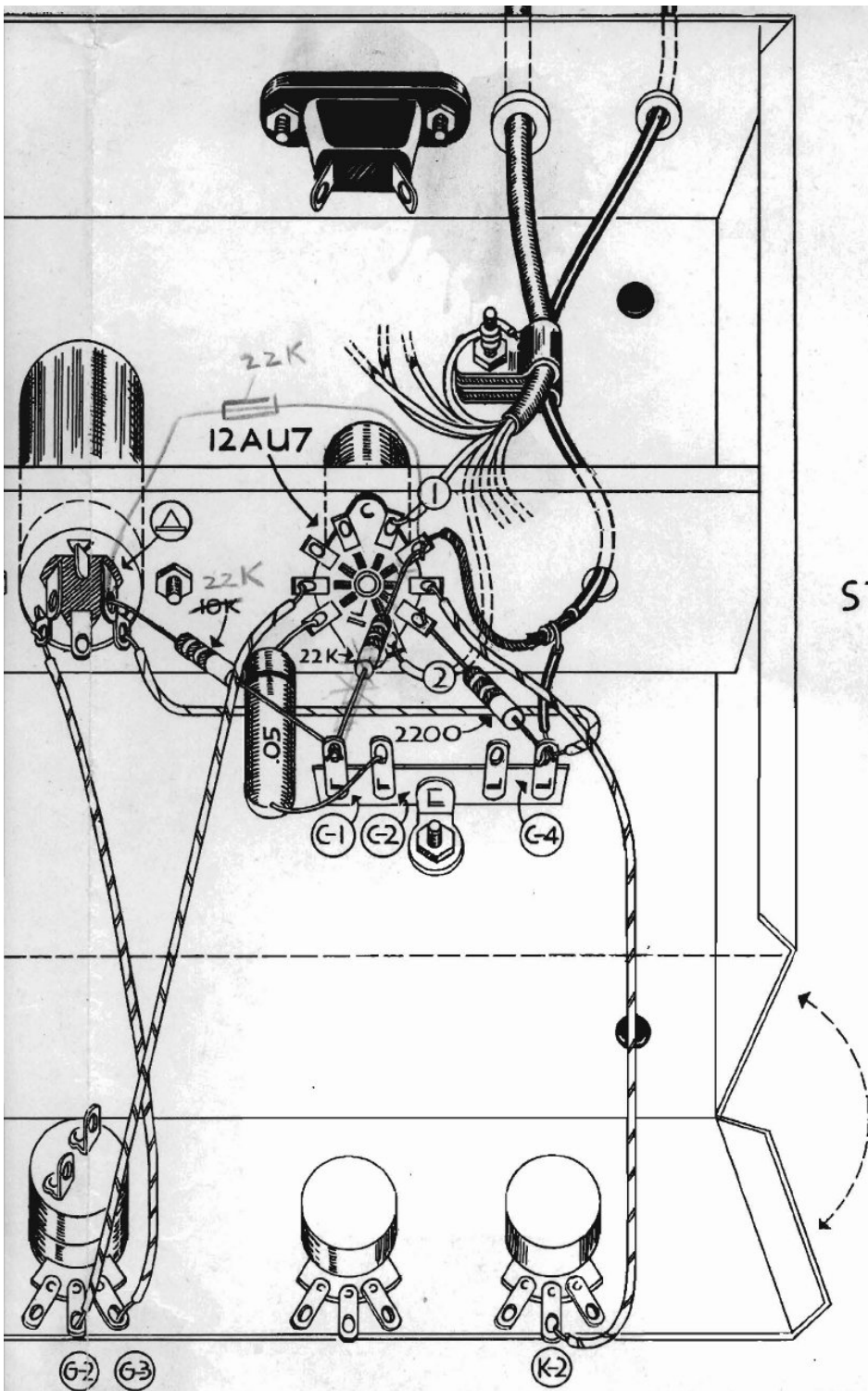

STEP 3.

This extra large scale copy is furnished to facilitate construction. It is suggested that this copy be fastened to a wall above the working area in order to provide a ready reference.

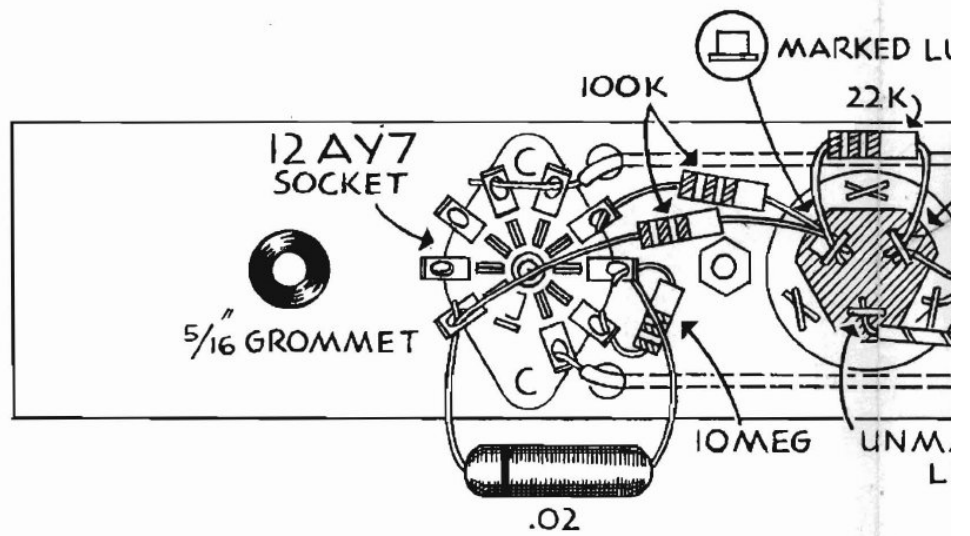
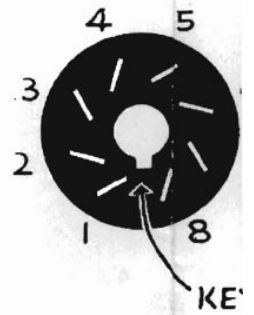
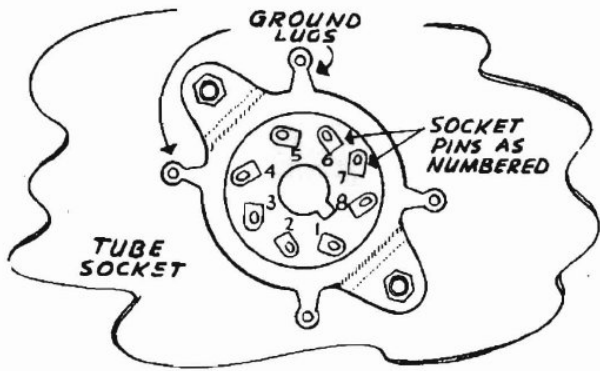

STEP

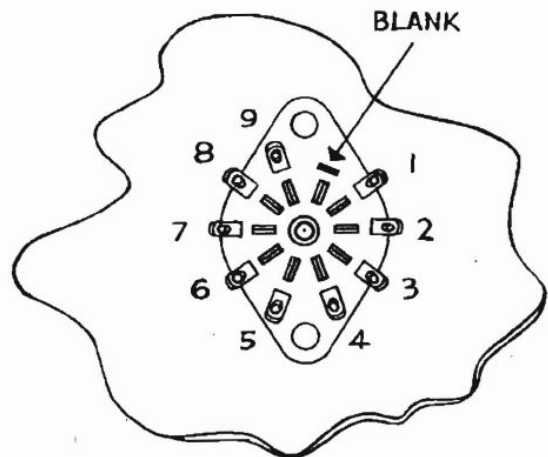
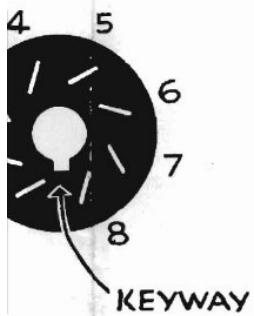

PIN NUMBERING ON NOVAL TUBE SOCKET

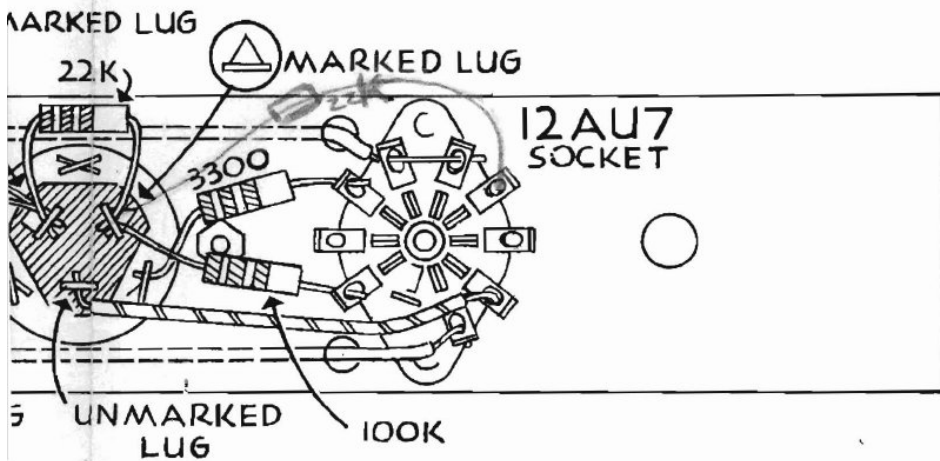

STEP 1.

This extra large scale copy is furnished to facilitate construction. It is suggested that this copy be fastened to a wall above the working area in order to provide a ready reference.

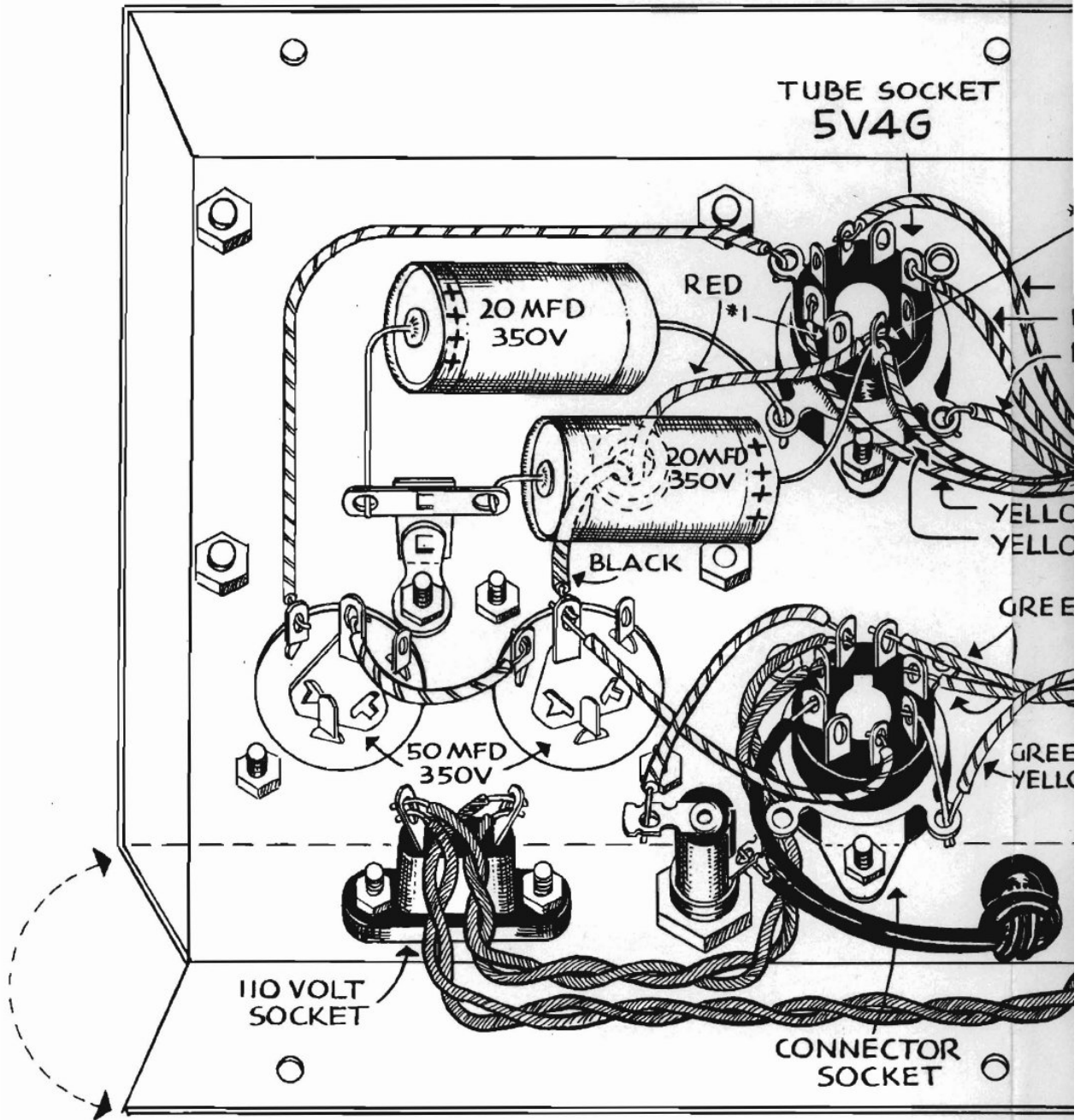

POWER SUPPLY I

KET

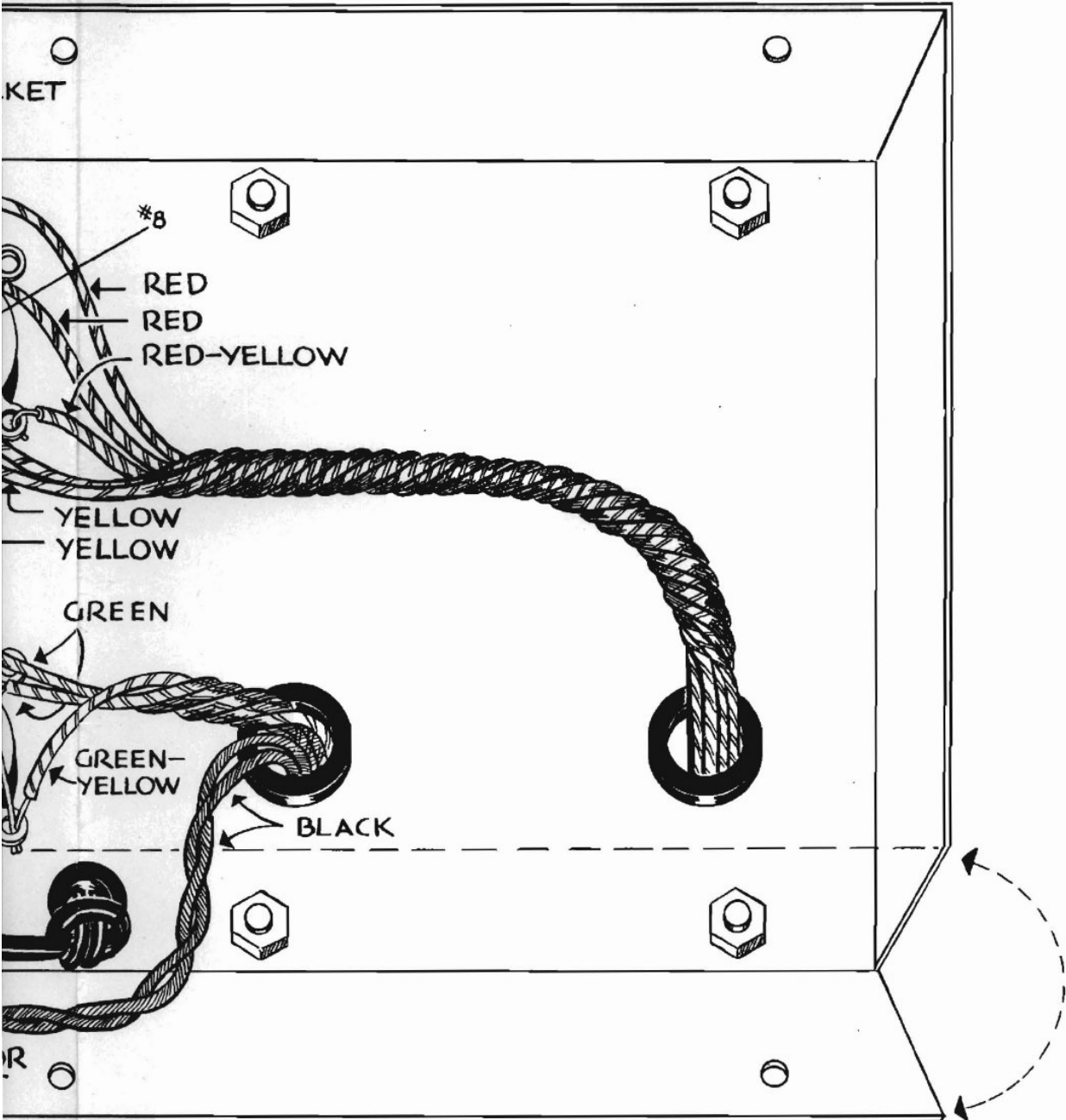

R

PLY PICTORIAL

HELPFUL KIT BUILDING INFORMATION

Before attempting actual kit construction read the construction manual through thoroughly to familiarize yourself with the general procedure. Note the relative location of pictorials and pictorial inserts in respect to the progress of the assembly procedure outlined.

This information is offered primarily for the convenience of novice kit builders and will be of definite assistance to those lacking thorough knowledge of good construction practices. Even the advanced electronics enthusiast may benefit by a brief review of this material before proceeding with kit construction. In the majority of cases, failure to observe basic instruction fundamentals is responsible for inability to obtain desired level of performance.

RECOMMENDED TOOLS

The successful construction of Heathkits does not require the use of specialized equipment and only basic tools are required. A good quality electric soldering iron is essential. The preferred size would be a 100 watt iron with a small tip. The use of long nose pliers and diagonal or side cutting pliers is recommended. A small screw driver will prove adequate and several additional assorted screw drivers will be helpful. Be sure to obtain a good supply of rosin core type radio solder. Never use separate fluxes, paste or acid solder in electronic work.

ASSEMBLY

In the actual mechanical assembly of components to the chassis and panel, it is important that the procedure shown in the manual be carefully followed. Make sure that tube sockets are properly mounted in respect to keyway or pin numbering location. The same applies to transformer mountings so that the correct transformer color coded wires will be available at the proper chassis opening.

Make it a standard practice to use lock washers under all 6-32 and 8-32 nuts. The only exception being in the use of solder lugs—the necessary locking feature is already incorporated in the design of the solder lugs. A control lock washer should always be used between the control and the chassis to prevent undesirable rotation in the panel. To improve instrument appearance and to prevent possible panel marring use a control flat nickel washer under each control nut.

When installing binding posts that require the use of fiber insulating washers, it is good practice to slip the shoulder washer over the binding post mounting stud before installing the mounting stud in the panel hole provided. Next, install a flat fiber washer and a solder lug under the mounting nut. Be sure that the shoulder washer is properly centered in the panel to prevent possible shorting of the binding post.

WIRING

When following wiring procedure make the leads as short and direct as possible. In filament wiring requiring the use of a twisted pair of wires allow sufficient slack in the wiring that will permit the twisted pair to be pushed against the chassis as closely as possible thereby affording relative isolation from adjacent parts and wiring.

When removing insulation from the end of hookup wire, it is seldom necessary to expose more than a quarter inch of the wire. Excessive insulation removal may cause a short circuit condition in respect to nearby wiring or terminals. In some instances, transformer leads of solid copper will have a brown baked enamel coating. After the transformer leads have been trimmed to a suitable length, it is necessary to scrape the enamel coating in order to expose the bright copper wire before making a terminal or soldered connection.

In mounting parts such as resistors or condensers, trim off all excess lead lengths so that the parts may be installed in a direct point-to-point manner. When necessary use spaghetti or insulated sleeving over exposed wires that might short to nearby wiring.

It is urgently recommended that the wiring dress and parts layout as shown in the construction manual be faithfully followed. In every instance, the desirability of this arrangement was carefully determined through the construction of a series of laboratory models.

SOLDERING

Much of the performance of the kit instrument, particularly in respect to accuracy and stability, depends upon the degree of workmanship used in making soldered connections. Proper soldered connections are not at all difficult to make but it would be advisable to observe a few precautions. First of all before a connection is to be soldered, the connection itself should be clean and mechanically strong. Do not depend on solder alone to hold a connection together. The tip of the soldering iron should be bright, clean and free of excess solder. Use enough heat to thoroughly flow the solder smoothly into the joint. Avoid excessive use of solder and do not allow a flux flooding condition to occur which could conceivably cause a leakage path between adjacent terminals on switch assemblies and tube sockets. This is particularly important in instruments such as the VTVM, oscilloscope and generator kits. Excessive heat will also burn or damage the insulating material used in the manufacture of switch assemblies. Be sure to use only good quality rosin core radio type solder.

Antenna General		Resistor General		Neon Bulb		Receptacle two-conductor	
Loop		Resistor Tapped		Illuminating Lamp		Battery	
Ground		Resistor Variable		Switch Single pole Single throw		Fuse	
Inductor General		Potentiometer		Switch double pole single throw		Piezoelectric Crystal	
Air core Transformer General		Thermistor		Switch Triple pole Double throw		1000 =	K
Adjustable Powdered Iron Core		Jack two conductor		Switch Multipoint or Rotary		1,000,000 =	M
Magnetic Core Variable Coupling		Jack three conductor		Speaker		OHM =	Ω
Iron Core Transformer		Wires connected		Rectifier		Microfarad =	MF
Capacitor General		Wires Crossing but not connected		Microphone		Micro Microfarad =	MMF
Capacitor Electrolytic		A. Ammeter V. Voltmeter		Typical tube symbol 	Binding post Terminal strip 	Wiring between like letters is	
Capacitor Variable		G. Galvanometer MA. Milliammeter uA. Microammeter, etc.				understood	

Courtesy of I. R. E.

HEATH COMPANY
BENTON HARBOR, MICHIGAN

THE WORLD'S
Finest
TEST EQUIPMENT
IN KIT FORM