



H. H. SCOTT  
**FULL COLOR**  
INSTRUCTION BOOK

LK-72-B

Copyright © 1963, H. H. Scott, Inc.

\$2.00

## INTRODUCTION

The first true high fidelity complete amplifier appeared in 1947, H. H. Scott's Model 210A. This remarkable instrument introduced a score of unusual design features, which today are accepted and used by all manufacturers. The engineering innovations introduced in the 210A are typical of H. H. Scott, a company which has continued to pioneer in designing and producing new and better audio instruments. The exceptional design and careful manufacture that went into the 210A have been proven over the years . . . most of them are *still* in service, after more than 16 years. They work perfectly and compare favorably to products available today.

H. H. Scott's philosophy is not only to develop new and better instruments, but also to produce equipment that will last. There is no built-in obsolescence in H. H. Scott products. These brief notes try to indicate how this is accomplished by using the latest example of the H. H. Scott engineering laboratories, the LK-72.

## WHAT IS THE FUNCTION OF A POWER AMPLIFIER AND A PREAMPLIFIER CONTROL CENTER

The purpose of a high fidelity power amplifier is to take weak signals, increase their strength tremendously, and convert them into watts of power necessary to move the cone of a speaker. It must do this without adding, subtracting, or altering the contents of the original signal in any way. Such alteration of the original program is referred to as "distortion."

The purpose of the preamplifier control center is twofold. First, it takes the exceptionally small output from the conventional magnetic phono pickup (3 to 16 millivolts in most cases) and steps it up to a level where it can be properly accepted by the power amplifier. The outputs of FM tuners, complete tape recorders, and crystal pickups are sufficiently strong so they do not need this preliminary preamplification and can be fed directly into the power amplifier.

The second function of the preamplifier control center is to permit the user to vary the sound to suit his taste. It permits him to increase or decrease the treble, bass, and volume. It permits him to select a wide range of program sources, reduce record scratch, and adjust record or tape equalization.

Your LK-72 offers on one compact chassis, four

pieces of precision equipment. There is a preamplifier control center and power amplifier for the left channel (Channel L), and a preamplifier control center and power amplifier for the right channel (Channel R). It is actually a remarkable accomplishment in engineering design, to have such outstanding laboratory performance on so simple and compact a unit.

## HOW DOES THE COMPLETE AMPLIFIER WORK

### PREAMPLIFIER STAGE

The very weak signals coming from the magnetic cartridge or tape head are fed into Mag High or Mag Low Inputs. They go to the first duo-triode 12AX7 tubes (V1 for the left or L channel, V101 for the right or R channel), where preamplification occurs.

Any noise or hum that creeps in at this critical stage will be amplified along with the program material and will be audible in the resultant sound. To avoid introducing noise, special pre-selected low noise tubes are used. Hum is usually caused by the 60-cycle AC used to heat the tubes. On all H. H. Scott amplifiers, DC is used instead of AC, so there is no possibility of hum appearing from this source. This DC is derived from the selenium rectifier, SRI, on your LK-72.

In addition to the preamplification, equalization is also accomplished. Equalization involves correcting for the bass cut and treble boost introduced on all phonograph records and prerecorded tapes to allow their manufacture. The equalization characteristics of H. H. Scott amplifiers is always within 2 db of the record manufacturer's (RIAA) specification.

Naturally, any distortion introduced at this first stage would be amplified along with the music in the subsequent stages. To keep distortion down to virtually unmeasurable amounts, negative feedback is employed in every stage of your LK-72.

Feedback is a method whereby part of the output signal is fed back into the input. Negative feedback indicates that the resultant input signal is reduced in strength. While this causes a loss in gain, it also virtually eliminates distortion.

## FIRST AUDIO AMPLIFIER STAGE

The preamplified signal goes to the first audio stage, another duo triode 12AX7 (V2 for Channel L, V102 for Channel R). The signal from tuners,

complete tape recorders, ceramic cartridges, and other high level program sources being much stronger, bypasses the preamplifier stage and goes directly to this first audio stage. Here the signal is further amplified and modified (if desired) by the tone controls. H. H. Scott uses feedback-type tone controls, giving the advantage of low distortion, of not affecting the midrange response, and of *being flat* when the control is in the flat position (flat position is "O" on the front panel, indicating that there is no tone control boost or attenuation).

The first audio amplifier stage also includes the low-frequency cutoff filter. The human ear cannot hear signals below 20 cycles per second. However, a good turntable or record will contain noises of lower frequency. These noises, which you cannot hear, are capable of being reproduced by the amplifier. Often these subsonic sounds will generate such enormous signals that they will waste much of the amplifier's power and adversely affect its ability to reproduce the desirable program material. The special filter used by H. H. Scott eliminates all these subaudible noises and permits the amplifier to concentrate its power in the audible range of 20 to 20,000 cycles per second.

## SECOND AUDIO STAGE AND PHASE SPLITTER

The pentode-triode 6U8/6GH8 (V3 for Channel L, V103 for Channel R) provides an additional stage of gain, and splits the phase for the push-pull output stage. The advantages of a push-pull output stage are higher power and lower distortion. To obtain the advantages of this system, it is necessary to have some means of inverting the phase of the signal so that one tube in the output stage will be exactly out of phase with the other (in other words — one will be "pushing" while the other is "pulling").

It is also essential that the phase splitter be able to send signals of exactly equal strength to each output tube. In most circuits this is accomplished by having special AC balance controls which can only be set with expensive laboratory equipment. In the LK-72, the AC balance controls are eliminated by using a true self-balancing phase splitter with special matched components. The DC balance controls are easily set by following the simple instructions given. No test equipment is needed. To further reduce distortion, negative feedback is applied to this stage as well.

## OUTPUT STAGES

Two 7591 pentodes are used in push-pull for each output stage (Channel L are V4 and V5, Channel R V104 and V105). The way these output

tubes are operated is typical of H. H. Scott standard design procedure. A tube manufacturer usually rates his tubes according to the average amount of heat dissipation they can handle. It is standard procedure for most engineers to use this "design center" in their circuits or even go beyond it to squeeze the maximum amount of power out of their amplifiers regardless of how this may affect tube life. H. H. Scott amplifiers operate all tubes, *particularly* the output tubes, well *below* manufacturer's dissipation design center. This assures long tube life and superior performance. On the LK-72 for example, the output tubes are operated at 75% of manufacturer's dissipation average.

There are other benefits from this conservative operation of the output tubes. Variations in tubes are not critical. It is not necessary to match the tubes to get low distortion as bias adjustments may be made.

The output tubes supply the necessary power to drive the speaker, but unfortunately the output impedance of the tubes will be high, while most speakers are of low impedance. In order to match these impedances, it is necessary to use output transformers. You can have the most elaborate and complicated amplifier circuitry in the world, but you will not have a good amplifier unless you have good output transformers. Unfortunately, good output transformers are very expensive. One of the indications of a good output transformer is its size and weight. Only a large well-designed transformer can supply low distortion and clean response from the lowest audible frequencies to the highest. The oversize transformers on your LK-72 do just that.

The most conspicuous aspect of an amplifier's performance is its power output. The LK-72 is rated at 40 watts per channel. You may notice that other amplifiers (many less expensive) with smaller transformers also claim similar or greater power. All amplifiers are rated at 1000 cycles, a frequency at which you do not need a particularly good amplifier to get good power measurements. The vital frequencies are those between 20 and 50 cycles. Here is where you need the power, and here is where only quality amplifiers can give it to you.

The Institute of High Fidelity Manufacturers (IHFM) recognized this problem and has evolved a new amplifier measurement — the "power band." Simply, the power band represents the range of frequencies over which the amplifier can supply a specified amount of power at the amplifier's rated distortion. The LK-72 has a power band extending down below 19 cycles and over 25,000 cycles. This is a meaningful specification of the performance of this remarkable amplifier.

An amplifier's stability is also important. An amplifier should only reproduce signals fed to it,



not originate signals of its own. Many amplifiers under certain conditions will start to produce a powerful supersonic oscillation. This can happen when the amplifier is used with electrostatic speakers (which act as a capacitive load), or if the amplifier is operated with no speakers attached (no load). In extreme cases this oscillation is capable of burning out an amplifier in a few minutes. H. H. Scott amplifiers, like the LK-72, are completely stable under all conditions — no load, resistive, inductive or capacitive load. This means that if the speaker wire should accidentally be disconnected, you need have no fear of damaging your amplifier.

We have often referred to the desirability of low distortion. A wide frequency response, ample power, and low hum and noise are important but cannot compensate for high distortion. This is important, but even more important is the distortion at normal listening levels. Many amplifiers will exhibit reasonably low distortion at full output, but actually turn out to have as much or more distortion at normal listening levels of 1 to 5 watts. This is self-defeating.

At normal listening levels, the total harmonic

distortion of the LK-72 is below 0.5%, which means it is so low it cannot be accurately measured with even the finest of laboratory instruments! The translucent sound from your LK-72 is proof of this low distortion.

## POWER SUPPLY

In order to supply the necessary voltages to all the stages of the amplifier a rugged power supply is needed. The husky oversize power transformer along with the GZ34/5AR4 rectifier and SRI selenium rectifier comprise the heart of the power supply. An important characteristic of the GZ34 is its slow warmup. This gives the other tubes and components an opportunity to reach normal operating condition before the full force of the high voltages and currents are transmitted by the rectifier. The electrolytics (condenser cans) are all specially designed and conservatively operated. These are other factors in the long life you can expect from the amplifier.

Heat can be a problem in any high power amplifier. Under normal conditions you can expect the amplifier to use about 175 watts of electricity. This will generate a considerable amount of heat. The heat has to be rapidly transferred away from the output stages where most of it is generated. If it is not, the life of the tubes and other components will be greatly curtailed. One of the ways the heat is carried away is by convection to the air. The many holes in the chassis are designed to encourage air circulation which well perform this function. Equally important is the use of electrolytic aluminum for the chassis material.

Most amplifier chassis are steel which is a less expensive material. Unfortunately steel is not a good conductor of heat so such units will have their output stages overheating even though the rest of the amplifier is cool. Aluminum is an excellent conductor of heat, so it rapidly conducts the heat away from output stages to other parts of the chassis where it can be readily transferred to the air.

In fact you may notice that your aluminum front panel is warm to the touch. This means that the heat is being transported away from the heat sources and that your amplifier is operating safely.

Another advantage of the aluminum chassis is that it is nonmagnetic so acts as a shield against induced hum from the power transformer. Conventional chassis made of steel, which is magnetic, are much more prone to this type of difficulty.

## CONCLUSION

There are many ingredients involved in designing a high quality complete stereo amplifier. However, as this discussion has attempted to show, compromise is not one of them.

# LK-72 PARTS LIST

## MECHANICAL AND HARDWARE PARTS

1	A-BC-10	Bottom Cover
4	A-FT-1	Plastic Feet
2	A-GR-3	Plastic Grommets
1	A-RC-2	Rear Chassis
1	E-CS-19	Control Shield
1	E-LT-AV-Y	Solder Pack
1	E-LT-SD	Screwdriver
4	EV-9MA-1	Tube Shields
2	F-SB-2.5	Fuses
4	H-DLW-8	Cup Washers
1	H-LW-3/8	Lock Washer
3	H-MS-632x1/4B	Machine Screws (#6)
13	H-N-3/8x1/2B	Brass Hex Nuts
4	H-N-832	Nuts
8	H-NC-8	Spring Clip Fasteners (4 installed)
3	H-NK-632	Lock Nuts
22	H-SMS-6x1/4 HW	Sheet Metal Screws
1	H-SMS-6x1/4 HW-B	Sheet Metal Screw (Bronze)
4	H-SMS-6x5/8 HWA	Sheet Metal Screws
8	H-SMS-8x3/8 HW	Sheet Metal Screws
4	I-NS-8	Nylon Sleeves
1	J-3-ST-5	Phone Jack
2	KN-P-6C	Knobs
4	KN-P-8	Knobs
2	KN-P-9C	Knobs
1	LK-72-M1	Main Chassis
1	LK-72-M2	Front Chassis
1	N-LK-72-1	Front Panel
1	V-SPL-NE-YF	Pilot Light
1	X-F-3AG	Fuse Post

## ELECTRICAL COMPONENTS

1	CEC-2x20/450-2x25/25	Electrolytic (C201)
2	CEC-2x30/500	Electrolytic (C202, C204)
1	CEC-4x100/75-CP	Electrolytic (C203)
2	PEC-222E	Pkg. Elect. Circuit
2	PEC-299	Pkg. Elect. Circuit
1	RCVD-500KT-3FSW	Potentiometer (P1)
1	RCV-1MST-3F	Potentiometer (P2)
2	RCVC-1MT-F	Potentiometers (P3, P4)
2	RCV-100K-PH	Potentiometers (P5, P6)
2	RCV-50K-PH	Potentiometers (P7, P8)
1	RWS-10-20	Stand-up Resistor (RWS-1)
1	RWS-20-8K	Stand-up Resistor (RWS-2)
1	RWS-10-1.2K	Stand-up Resistor (RWS-3)
1	SR-B60/C200	Selenium Rectifier (SR-1)
1	SRW-27	Stereo Selector (SW-1)
1	SRW-33-1	Input Selector (SW-2)



AGR-3 PLASTIC GROMMET

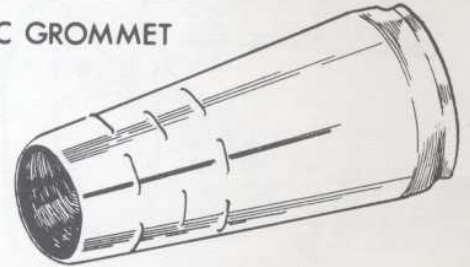

EV-9MA-1 TUBE SHIELD



H-DLW-8 CUP WASHER



MACHINE SCREW

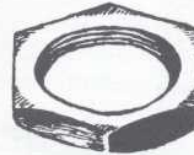

H-N-3/8 x 1/2 HEX NUT



H-N-832 HEX NUT



SPRING CLIP FASTENER

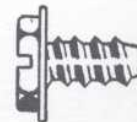

H-SMS-6 x 1/4 HW SHEET METAL SCREW



I-NS-8 NYLON SLEEVE

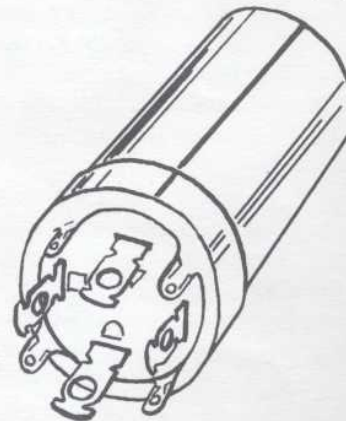

CEC ELECTROLYTIC CAPACITOR

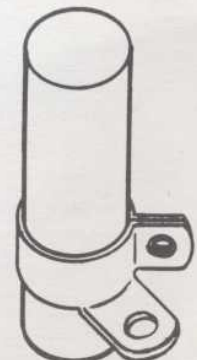

STANDUP RESISTOR

1	TR-13-3-2	Power Transformer (T1)
2	TRA-11-2	Output Transformers (T2, T3)
1	5AR4	Tube
2	6U8/6GH8	Tubes
4	12AX7	Tubes
4	7591	Tubes
1	WAC-1.5	1½ Ft. Audio Cable
1	WAC-3A	3 Ft. Audio Cable
6	CC-.001	Ceramic Capacitors
1	CC-.01	Ceramic Capacitor
2	CC-.05	Ceramic Capacitors
1	CC-.02	Ceramic Capacitor
2	CC-5 NPO	Ceramic Capacitors
4	CC-220	Ceramic Capacitors
4	CC-6800	Ceramic Capacitors
4	CM15-47	Mica Capacitors
2	CM15-120	Mica Capacitors
2	CM15-150	Mica Capacitors
2	CM15-180	Mica Capacitors
2	CPM-.0033	Tubular Capacitors
8	CPM-.022	Tubular Capacitors
2	CPM-.047	Tubular Capacitors
8	CPM-1	Tubular Capacitors
2	CET-4/250	Electrolytic Capacitors
1	CET-50/75	Electrolytic Capacitor
2	RC21-150 Ohm	½ Watt Resistors
2	RC21-1K	½ Watt Resistors
5	RC21-1.5K	½ Watt Resistors
4	RC21-2.2K	½ Watt Resistors
5	RC21-2.7K	½ Watt Resistors
1	RC21-4.7K	½ Watt Resistor
6	RC21-8.2K	½ Watt Resistors
2	RC21-10K	½ Watt Resistors
3	RC21-22K	½ Watt Resistors
1	RC21-33K	½ Watt Resistor
2	RC21-47K	½ Watt Resistors
5	RC21-82K	½ Watt Resistors
10	RC21-100K	½ Watt Resistors
4	RC21-150K	½ Watt Resistors
4	RC21-270K	½ Watt Resistors
8	RC21-330K	½ Watt Resistors
5	RC21-470K	½ Watt Resistors
1	RC21-680K	½ Watt Resistor
6	RC21-1M	½ Watt Resistors
6	RC21-2.2M	½ Watt Resistors
1	RC21-3.3M	½ Watt Resistor
2	RC31-3.3 Ohm	1 Watt Resistors
3	RC31-18 Ohm	1 Watt Resistors
2	RC31-68 Ohm	1 Watt Resistors
1	RC31-4.7K	1 Watt Resistor
4	RC31-15K	1 Watt Resistors
4	RC31-100K	1 Watt Resistors
1	RC51-270 Ohm	3 Watt Resistor
1	RW-4-33	Wire Wound Resistor
2	RW-5-60	Wire Wound Resistors

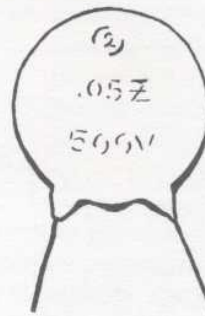

CC  
CERAMIC  
CAPACITOR

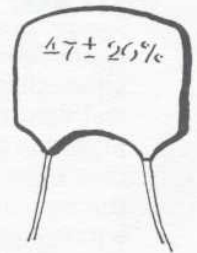

CM  
MICA  
CAPACITOR



RC  
½ WATT RESISTOR



CPM  
MOLDED TUBULAR  
CAPACITOR

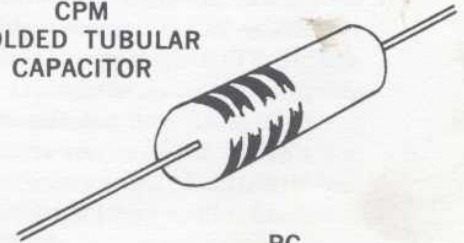

RC  
1 WATT RESISTOR

3 WATT RESISTOR

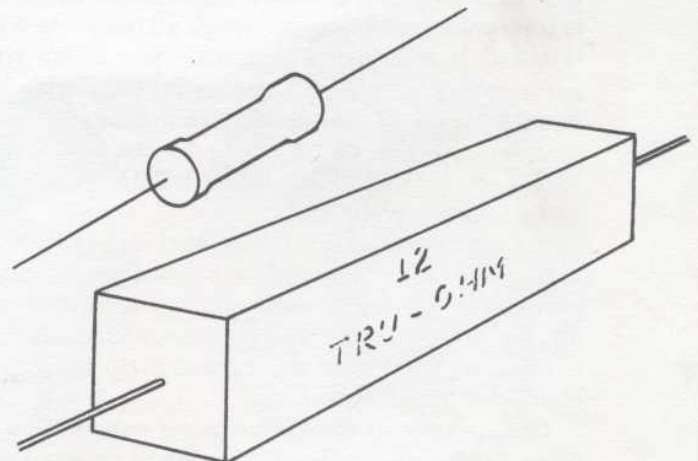

RW  
WIRE WOUND RESISTOR

# INSTRUCTION FOR THE MODEL LK-72 30 WATT COMPLETE STEREO AMPLIFIER

The LK-72 is a complete two-channel stereo amplifier consisting of dual 40 watt power amplifiers and dual preamplifiers on a single chassis. It employs the same engineering concepts and features that have made Scott amplifiers the standard in the industry. Conservatively designed, the LK-72 will bring you years of listening pleasure.

## IMPORTANT:

Every effort has been made to insure that this kit, when assembled, will perform perfectly. In order to achieve this result, you must read all of the instructions carefully and follow them precisely. Let us repeat . . . READ ALL INSTRUCTIONS CAREFULLY . . . FOLLOW THEM EXACTLY.

## UNPACKING YOUR KIT-PACK

There are no particular precautions to be observed in unpacking your kit, but you should take care not to mislay any small items or packages. If you desire you can work right inside the kit package. It will help protect your work table. When you want to stop working for a few hours, just close the cover and put the whole kit away out of sight of the wife . . . out of reach of the kids. You will find the Kit-Pak cover an ideal rest for the instruction book and Part-Charts.

## CHECK THE PARTS

On page 4 of this manual is a descriptive list of the parts included. Before beginning the assembly it is recommended that you check all the parts with this list. It will insure that there are no missing parts, and will help you become familiar with the various items. If you should accidentally damage or misplace any parts, write to the LABORATORY KIT SERVICE DEPARTMENT at the factory immediately.

A four foot length of insulated wire has been supplied. It is to be used to replace any missing wires or ones accidentally damaged. Simply cut off the length required (a convenient ruler is printed on the inside cover) and strip off 1/4" of insulation at each end.

Occasionally we may make minor substitution of parts. Such substitutions are carefully checked and the parts supplied will work as satisfactorily as those specified in the manual. These changes will

be obvious and are mentioned here only to prevent confusion in checking the parts list. For example, .005  $\mu$ f capacitors are used interchangeably with .0047  $\mu$ f capacitors. This will also be true as regards the body colors of parts in relation to the colors shown in the booklet.

## TOOLS REQUIRED

A small screwdriver is provided. In addition, you will need a pair of long nose pliers, a regular size screwdriver, a pair of wirecutters, and a soldering iron or gun. A 35 watt (or more) pencil type soldering iron is actually the easiest to use. The iron should be supplied with a small tip. If a soldering gun is used, it should also have a small tip, and should be used carefully because of the enormous heat it supplies.

## SIMPLIFIED SOLDERING AND WIRING INSTRUCTIONS

THE ONLY TYPE OF SOLDER YOU SHOULD USE IS 60/40 ROSIN CORE SOLDER. Under no circumstances should you use Acid Core solder. All guarantees are voided if Acid Core solder is used.

Here's how to solder joints correctly (see Figure 2):

1.  Before using the soldering iron or gun, the tip must be tinned for ease of use. First heat up the iron. Then when the tip is hot, wipe with a cloth till bright and shiny, and apply a generous amount of solder. Remove any excess. Repeat this process for all sides of the tip.
2.  Make sure that all leads (wires) and terminals to be soldered are completely clean. Do not use fluxes or paste of any sort.
3.  The leads should be mechanically secure before soldering. This does not mean wrapping leads around the contacts several times. It means a single turn around the contact which is then pinched tightly with the long nose pliers. If the wire is too large for bending, position the wire so that a good solder connection can still be made.
4.  LEADS ON RESISTORS, CAPACITORS, AND SIMILAR COMPONENTS ARE GENERALLY MUCH LONGER THAN THEY NEED TO BE TO MAKE THE INDICATED CONNECTIONS. IN THESE CASES, THE EXCESS LEADS SHOULD BE CUT OFF BEFORE THE PART IS ADDED TO THE CHASSIS. In general, the leads should be long enough to reach their termination allowing for a little left over to make a good mechanical

joint. A very handy way of gauging the length of lead to trim off is to superimpose the capacitor or resistor right on the pictorial. The pictorials are all full scale, so by placing the component over its picture and allowing about  $\frac{1}{4}$ " extra on each end for the mechanical joint, you can shorten the leads quickly and accurately.

Sometimes a lead will not seem quite long enough to reach the desired mounting point. In such a case, the terminal lug can be bent slightly to make the connection possible.

5.  Place a flat side of the soldering iron tip against the joint to be soldered until it is heated sufficiently to melt the solder.
6.  Place the solder against the heated terminal (with the soldering iron still in contact) and it will immediately flow over the joint. Use only enough solder to thoroughly wet the joint. Too much solder may cause short circuits. The soldering iron does not actually come into contact with the solder, only with the joint. It is the heated joint that melts the solder.
7.  As soon as sufficient solder has flowed, remove the solder and then a second later, the iron. Use care not to move the leads until the joint has hardened (about 5 seconds). A good solder joint should appear to be bright and shiny. Check the joint for rigidity. If it is not firm and tight, reheat the joint and permit the solder *already present* to flow again. Sometimes a little more solder will have to be added.
8.  When soldering certain of the components, such as diodes and resistors, it is advisable to use no more heat than is necessary. Excessive heat can damage these components.

9.  Keep the soldering iron clean and bright by occasionally wiping with a rag. The iron does not have to be cooled for this purpose. If you have never done any soldering before, it would be an excellent idea to practice on scraps of wires before beginning.
10.  THE BOTTOM VIEW PICTURE OF THE COMPLETED AMPLIFIER (FIGURE 1) WILL BE VERY HELPFUL AS A GUIDE TO THE CONSTRUCTION OF YOUR AMPLIFIER

## BASIC ELECTRICAL ASSEMBLY PROCEDURE

Your amplifier kit includes three separate sub-assemblies: the front (with all the controls and knobs), the main (with all the tube sockets), and the rear (with all the input and output jacks and terminals). You will construct each sub-assembly separately and then combine them to make a complete amplifier. The symbol *F* refers to the front, *M* to the main, and *R* to the rear.

Each terminal, tube, transformer, etc. has a code number (i.e. T1, V2, and so forth). Every pin on each of these terminals, or tube sockets is also numbered (i.e. pin 1, pin 2, and so forth). The instructions will call for a wire to be connected to pin 3, V4, for example. With the instructions will be a pictorial, clearly showing in full color the connection to be made and its location. With this information you should experience no difficulty in making the correct connection.

A series of Part-Charts are provided with all the necessary resistors and capacitors mounted. Each chart applies to a particular page of the electrical assembly instructions.

For example — in the instructions that follow

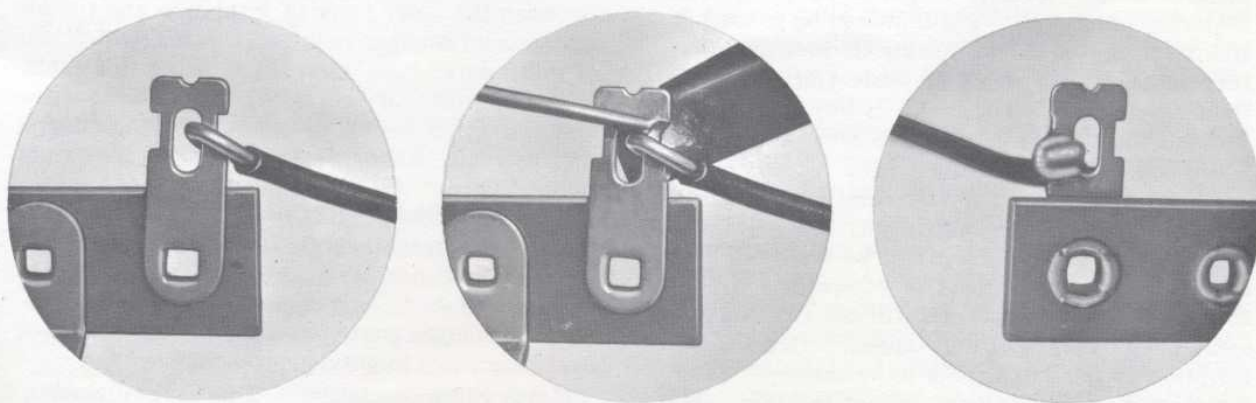

FIGURE 2

you will find a page marked "Assembly Group BF-4." The "B" indicates that this is part of the electrical assembly. The "F" indicates that you will be working on the "front." The "4" means that this is the fourth page of instructions for electrical assembly of the front. On the sheet of Part-Charts, you will find a Part-Chart BF-4. Take this out and keep it next to you when working on this page. The first step on the page is called BF4-1 and refers to a PEC-299 packaged electrical circuit. The first part on the Part-Chart is a PEC-299. The pictorial on the top of the page will show exactly where this part will go. The part is mounted as directed and the step is checked off as completed.

The many wires used in the amplifier kit are packed in a small plastic sleeve. This sleeve contains three separate bundles, clearly marked. For example — Assembly Group BF-1 involves connecting a group of wires of different colors and lengths. Open the bundle of wires marked "Front," and spread them out near you. The first step, BF1-1, calls for a 3 $\frac{3}{4}$ " Blue/White wire. From the Blue/White wires select the ones of the appropriate length and hold them up to the ruler printed on the inside cover of the Kit-Pak. Once you have the correct one, you may proceed as above.

IT IS IMPORTANT TO POSITION THE WIRES OR COMPONENTS IN APPROXIMATELY THE SAME POSITION AS SHOWN IN THE PICTORIAL. BE AS NEAT AS POSSIBLE AS THIS WILL GREATLY CUT DOWN ON MISTAKES, SHORTS, AND OTHER DIFFICULTIES. NEATNESS WILL ALSO ALLOW YOU TO MORE EASILY CHECK YOUR WIRING.

If the symbol — (S-) appears in the instructions after any connection, it means that the particular connection with all other wires on the same pin, should be soldered. After the "S" will appear a number. This number indicates exactly how many leads or wires are supposed to be connected to the terminal or pin in question. For example: connect an Orange wire to pin 2, V6 (S-3). The soldering number (S-3) will always be printed in red, so it can be found quickly. It indicates that there should be 3 wires or leads (including the Orange one) connected to pin 2, V6, and that all three of them are to be soldered. This provides an additional check for wiring errors.

Do not solder any connection that is not marked with an (S-). Other connections are yet to be made to this pin before it can be soldered. Frequently one end of a lead or component will be soldered while the other end will not (for the moment). The (S-) will only appear after the description of the end that is to be soldered. After completing the soldering, cross out the (S-) symbol with your pencil indicating that it has been done. This is in addition to checking off each step.

In this way you can glance over the assembly instructions and spot any (S-) that has not been crossed out, indicating that you may have overlooked a joint to be soldered.

**A new additional, simplified method for checking each step for soldered joints has been provided. Every pin that should have been soldered on any given page is colored red. When you complete each page, check the soldered pins on your unit against the colored pins on the drawing. If they do not agree, you have made a mistake. Go back through the steps and check the soldering instructions once again to find the mistake.**

The instructions which follow have been arranged in a logical order to insure perfect results. Follow them exactly, checking off each step as completed.

## TYPES OF WIRE PROVIDED

Regular hook-up wire — These are the standard insulated wires that you will be using most of the time. They will be found in bundles for the different portions of the assembly procedure.

Buss wire — This is a term used to describe short pieces of uninsulated wire. A bundle of buss wire will be found in one of the hardware bags.

Mic Lapel — This is a type of cable which has one insulated length and one uninsulated length of buss wire inside. The cable itself has a brightly colored outside insulation.

Conductive Vinyl — This is large hollow tubing, usually either black or white in color, which has a hollow tube of conductive material inside. Between the outer layer of insulation and the inner layer of conductive material is a single strand of uninsulated buss wire. When using this cable, it is important to prevent the inner conductive material from becoming exposed and causing a short circuit. Always keep the outer insulation completely over it.

Conductive Cable (ESS) — This is hollow tube with a black or white outer insulation and a spiral metal shield inside.

Spaghetti — A common name to describe hollow black insulation material. This tubing is slipped over bare wires to provide protection.

Heavy Black Insulation — This is  $\frac{1}{4}$ " diameter, flexible, hollow tubing, somewhat like spaghetti but of larger size.

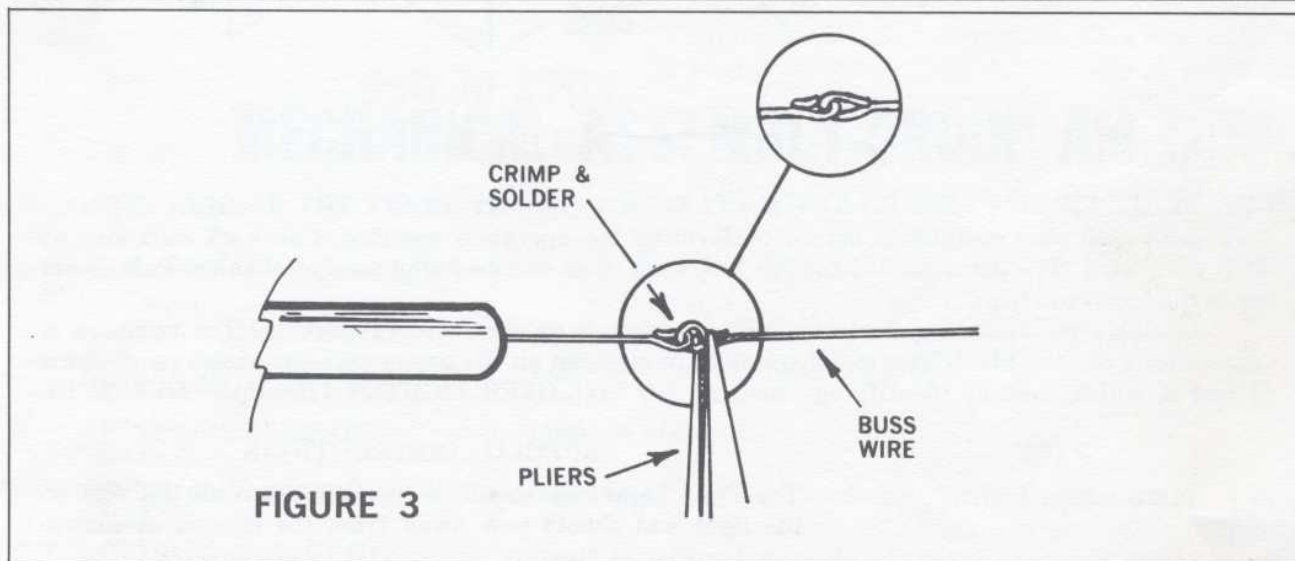
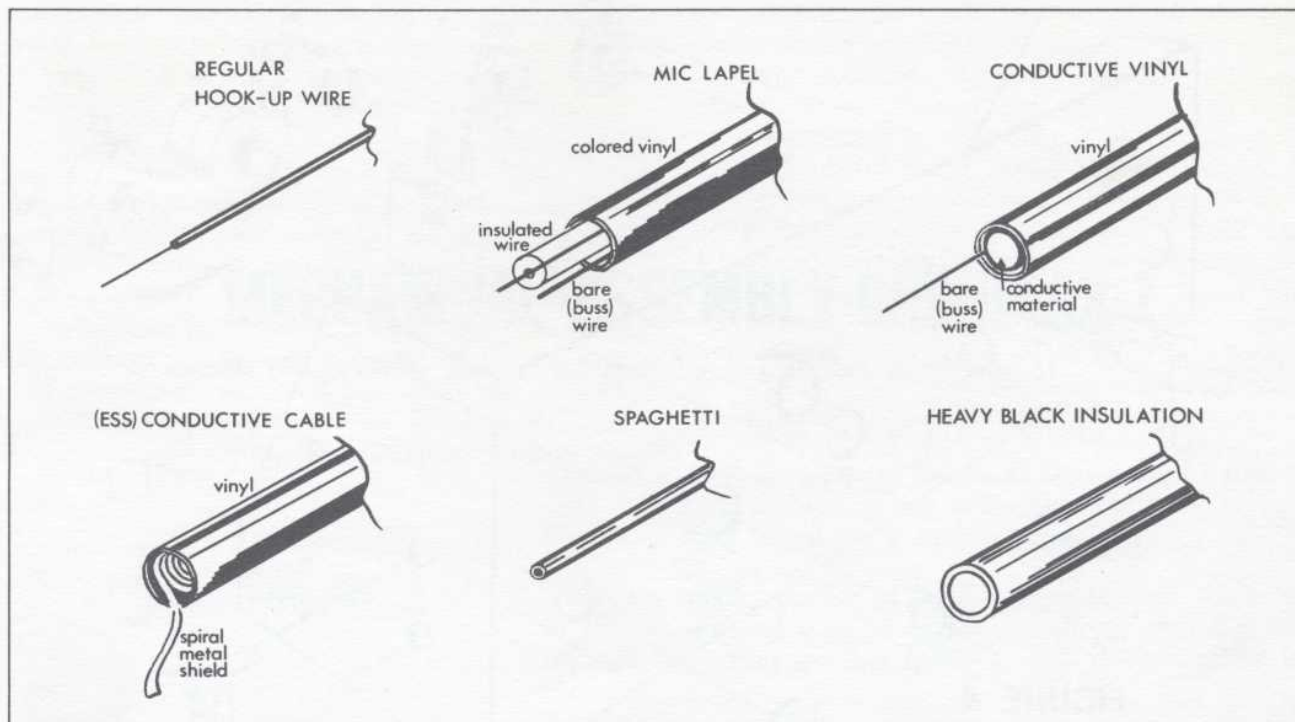

## WHAT TO DO IF YOU MAKE A MISTAKE

No matter how careful you may be, it is still possible to break something accidentally or to cut a lead too short. We might add that if you work when tired, or try to do too much, too fast, then the possibility of mishap increases greatly. Nevertheless, it is easy to correct most common errors.

**1. Cutting a wire or lead too short** — If you cut the wire from one of the components too short you can easily correct it by taking a small piece of un-insulated wire (buss wire) and splicing it on as shown in Fig. 3. If a wire supplied is damaged, you can cut off a replacement from the 4 feet of spare wire supplied.

**2. Breaking a terminal strip** — The terminal strips are quite sturdy and will withstand a great deal of handling. Nevertheless, if you are extremely rough, a terminal pin can be broken off. If this happens, make all connections to the small hole below the broken pin. Be careful to avoid having any of the bare wires touch the chassis. If the phenolic material cracks but does not break off, you can continue on as the wires themselves will keep the broken piece in place.

In the unlikely circumstance that the entire terminal strip breaks off, it is necessary to replace it. Write to the parts department at the factory for a replacement. Drill out the rivet holding the broken strip, using a number 28 drill. Mount the replacement with a regular 6-32 x 1/4" machine screw, lockwasher, and nut.

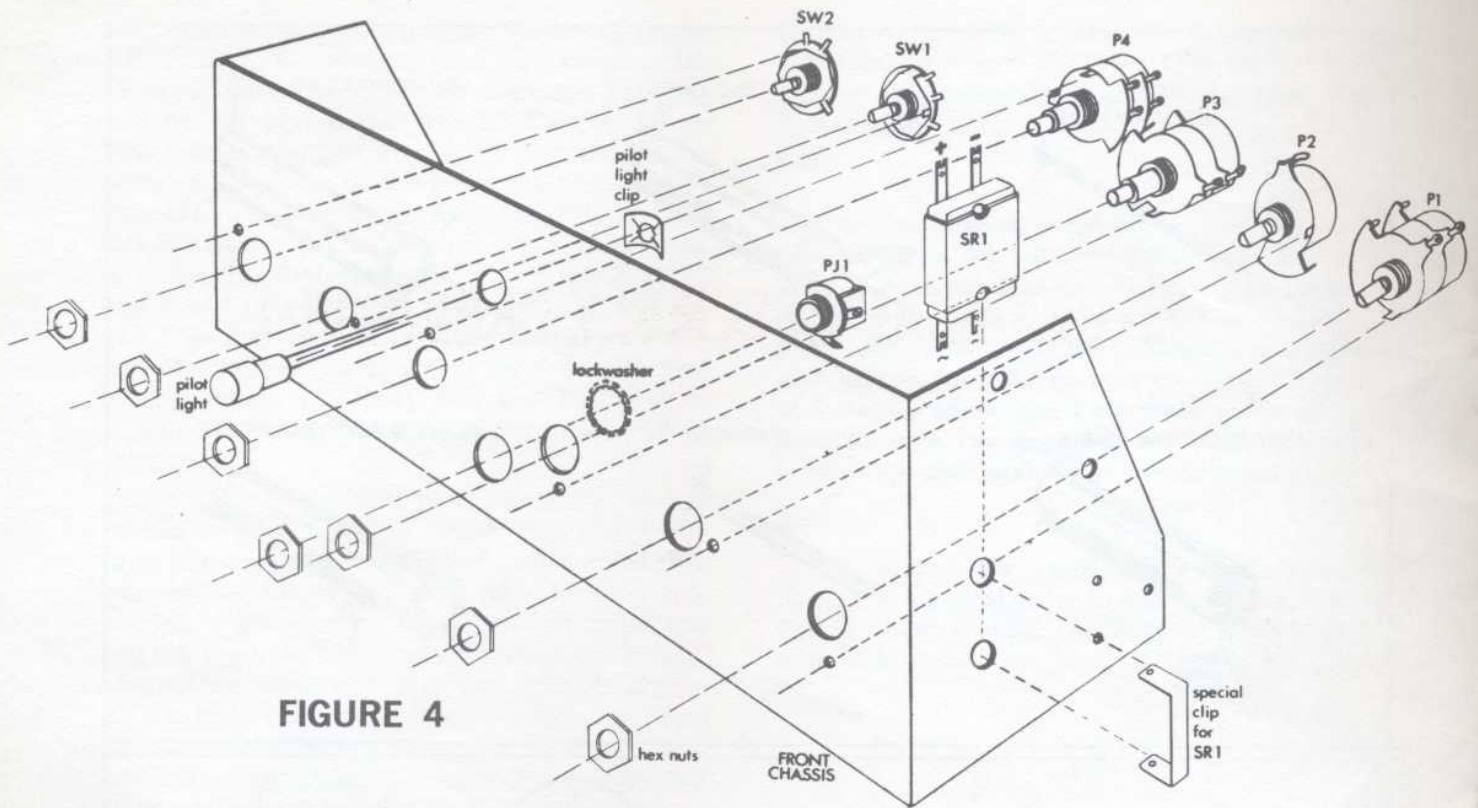

FIGURE 4

Read each step completely before performing the operation specified. Check off each step as it is completed. The parts needed for the following steps will be found on a mechanical Part-Chart or in the hardware bags.

Assemble the following parts to the front chassis as shown in (Figure 4). The numbers in parenthesis are the identifying numbers and are stamped on the parts, with the exception of items 1 and 2, which have no identifying numbers. **DO NOT OVER TIGHTEN THE BASS HEX NUTS.**

PART	SPECIAL INSTRUCTIONS
1. <input type="checkbox"/> Amber Pilot Light	The Pilot Light clip should be pressed down all the way on the light and should bow away from the chassis as shown.
2. <input type="checkbox"/> PJ-1 — Phone Jack	Place lock washer on shaft before assembling to chassis. <b>Be sure to position as shown.</b>
3. <input type="checkbox"/> SR-1 (B60 C200)	Plus (+) and minus (-) signs <b>MUST</b> be positioned as shown. Twist both ends of the clip 90° to lock SR-1 in place.
4. <input type="checkbox"/> P1 (RCVD-500KT-3FSW)	Insert as shown in (Figure 4). Align the locating lug with the small hole.
5. <input type="checkbox"/> P2 (RCV-1MST-3F)	Insert as in Step 4.
6. <input type="checkbox"/> P3 (RCVC-1MT-F)	Insert as in Step 4.
7. <input type="checkbox"/> P4 (RCVC-1MT-F)	Insert as in Step 4.
8. <input type="checkbox"/> SW-1 (SRW-27)	Insert as in Step 4.
9. <input type="checkbox"/> SW-2 (SRW-33-1)	Insert as in Step 4.

## MECHANICAL ASSEMBLY GROUP AR-1

Assemble the following parts to the rear chassis as shown in (Figure 5).

PART	SPECIAL INSTRUCTIONS
1. <input type="checkbox"/> Fuse Post	Position so that the pins are <b>exactly</b> as shown. Insert fuse in cap — push in slightly on cap and rotate clockwise to lock the fuse in place. Bend pin 2 upward slightly.
2. <input type="checkbox"/> Plastic Grommets	Insert the smaller portion of the grommets through the holes in the chassis and then press the remaining section down through the center portion firmly to lock the grommets in place.

## MECHANICAL ASSEMBLY GROUP AM-1

**NOTE: REMOVE THE THREE TRANSFORMERS FROM THE CHASSIS AND SET THEM ASIDE.**

Assemble the following parts to the main chassis as shown in (Figure 5).

PART	SPECIAL INSTRUCTIONS
1. <input type="checkbox"/> P5 (RCV-100K-PH)	Insert locating lug into small hole.
2. <input type="checkbox"/> P6 (RCV-100K-PH)	Insert as in Step 1.
3. <input type="checkbox"/> P7 (RCV-50K-PH)	Insert as in Step 1.
4. <input type="checkbox"/> P8 (RCV-50K-PH)	Insert as in Step 1.
5. <input type="checkbox"/> RWS-1 (20 $\Omega$ )	Insert from the top of the chassis as shown. Use one of the small #6 machine screws and lock nuts to secure it in place.
6. <input type="checkbox"/> RWS-2 (8K or 8000)	Insert as in Step 5.
7. <input type="checkbox"/> RWS-3 (1.2K or 1200)	Insert as in Step 5.
8. <input type="checkbox"/> C201 (CEC 2X20/450-2X25/25)	Orient the square, triangle and semi-circle identification marks on the base of the capacitor as shown and insert it into the matching hole on the top surface of the chassis.
9. <input type="checkbox"/> C202 (CEC 2x30/500)	Insert as in Step 8.
10. <input type="checkbox"/> C203 (CEC 4x100/75 cp)	Insert as in Step 8.
11. <input type="checkbox"/> C204 (CEC 2x30/500)	Insert as in Step 8.

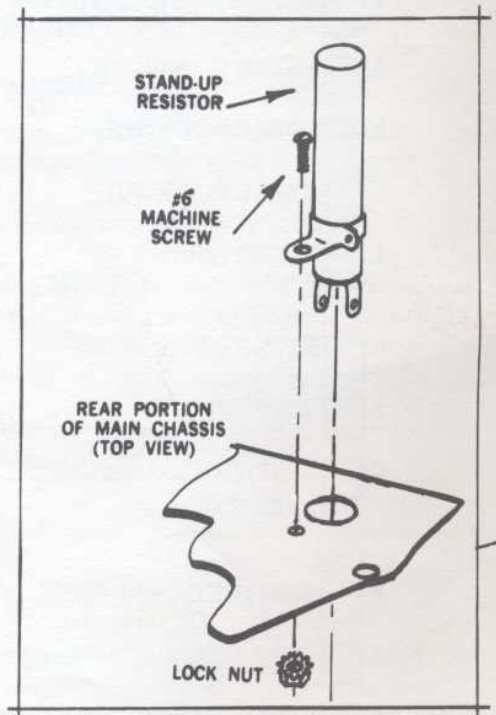
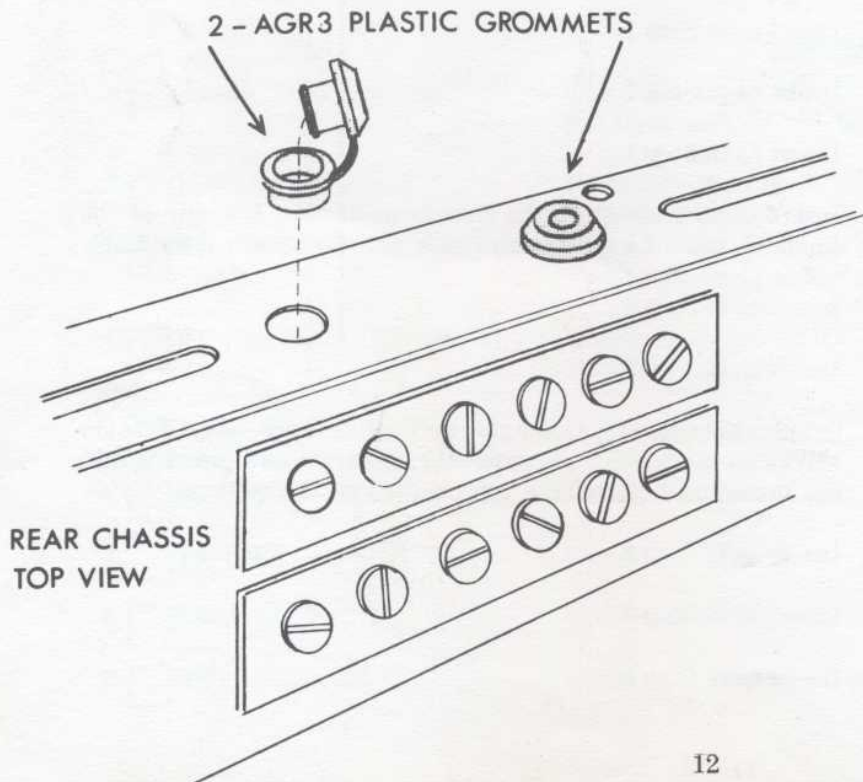
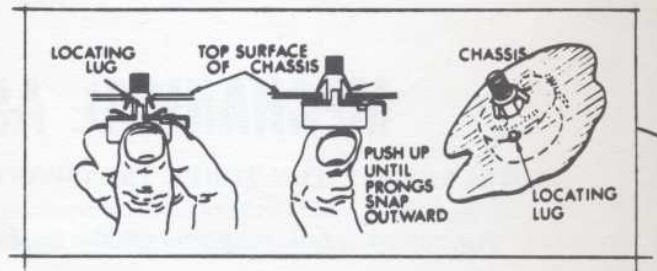
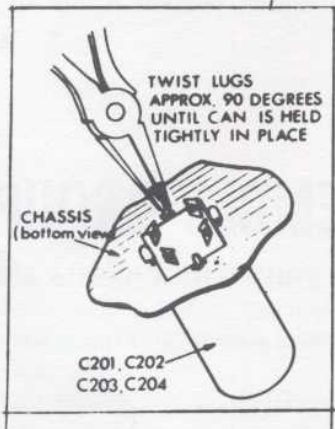
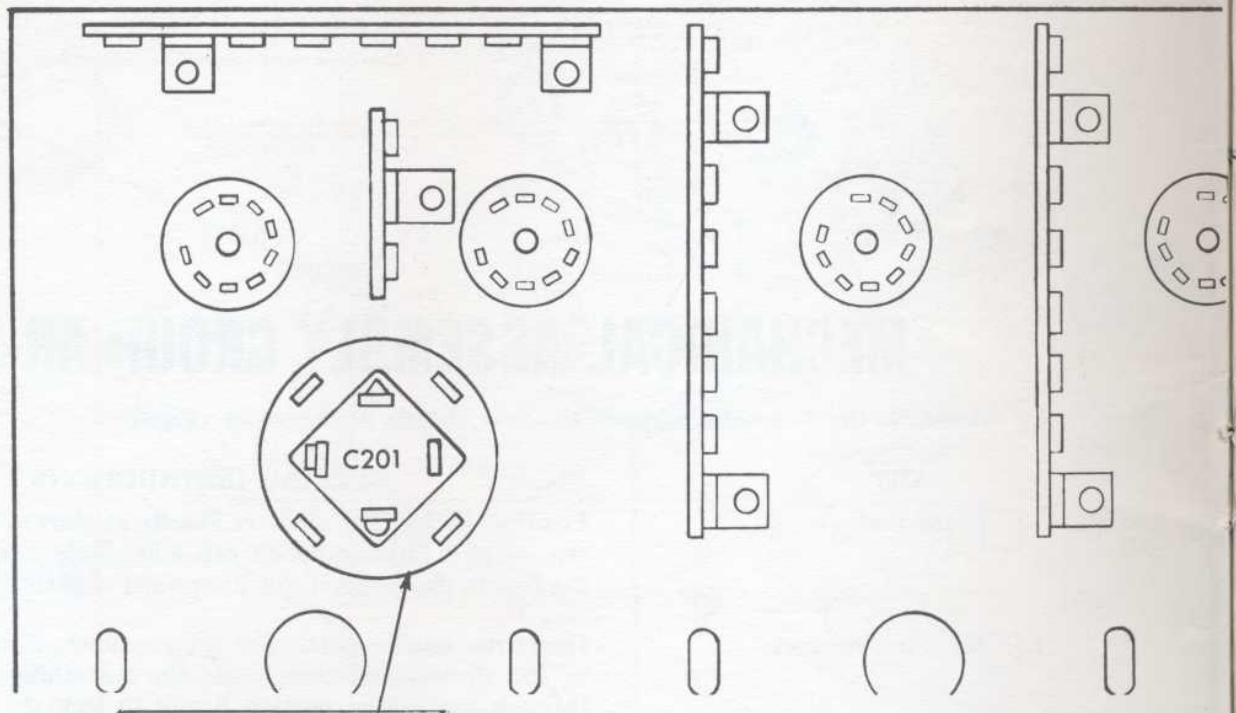

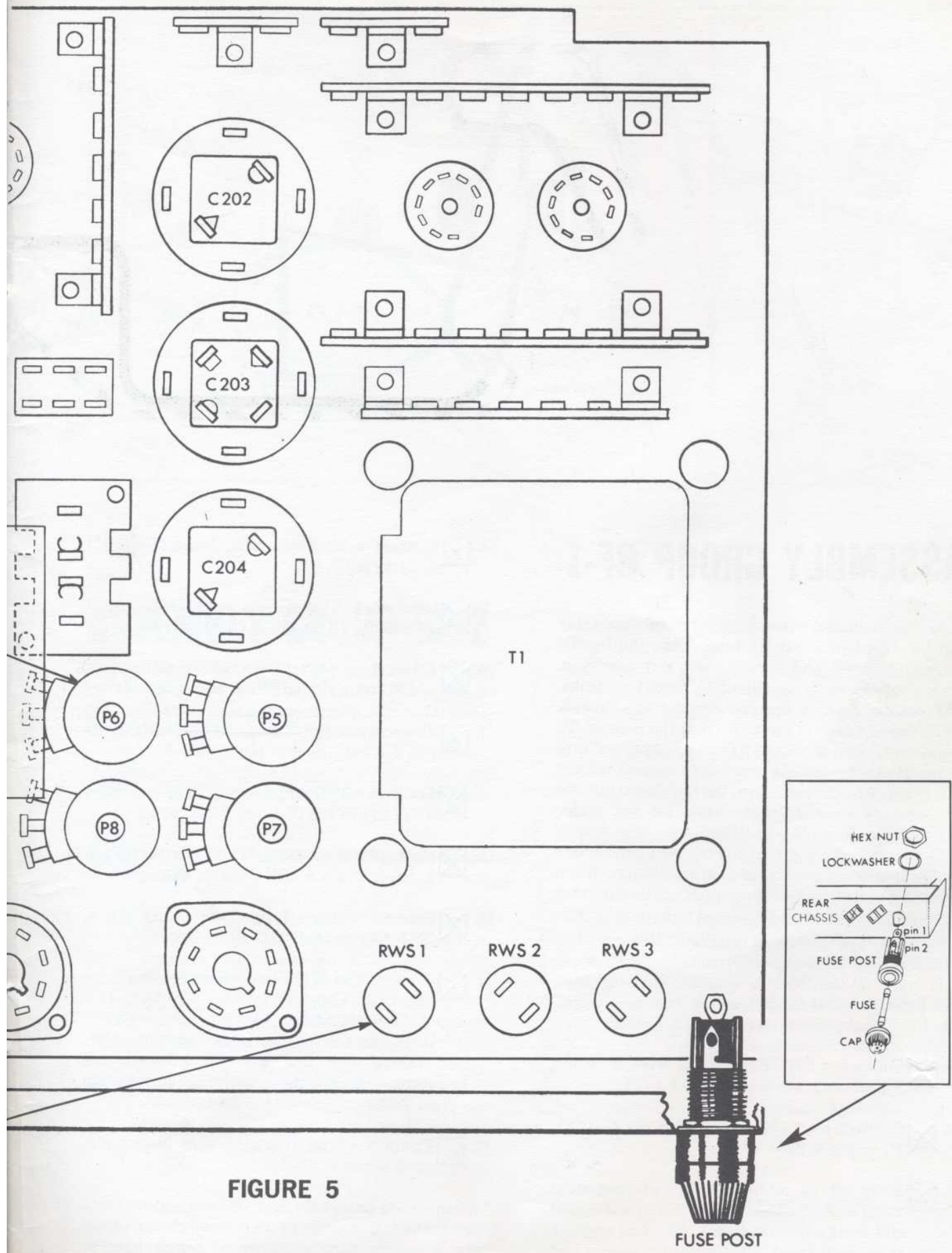
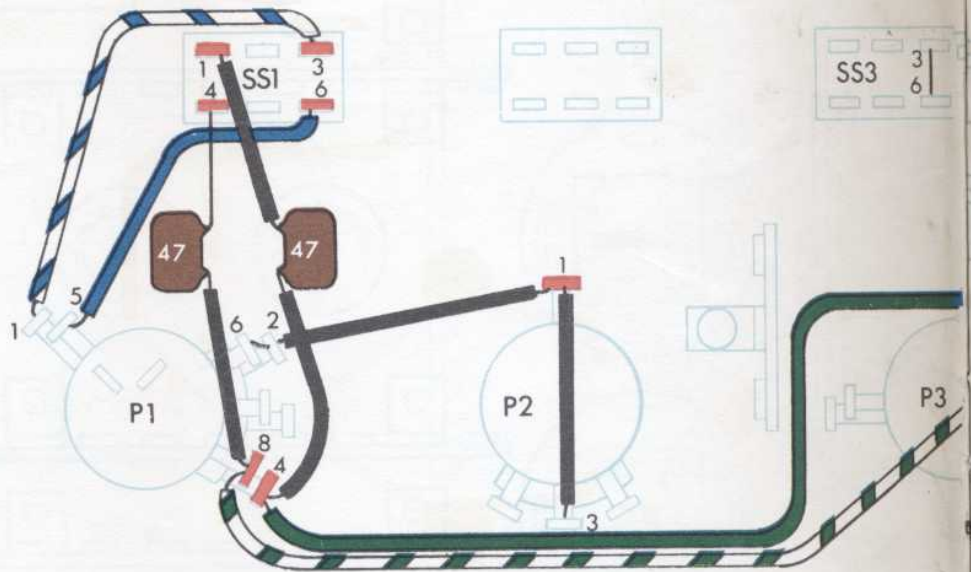

FIGURE 5

FUSE POST



## ASSEMBLY GROUP BF-1

All the insulated wires needed for this assembly will be found in a plastic tube. Take the bundle marked "Front" and spread them out near you. Several of the controls (like P1) have two decks. The *bottom* deck is the one *nearest* the chassis, while the *top* deck is *farthest* from the chassis. To avoid confusion, the word "Top" or "Bottom" will be inserted after the pin number to insure that you will connect to the right pin. On the diagrams, the bottom pins are the longer ones. Do not solder until you see the solder instructions.

SW-1 and SW-2 have several pins which are double (such as pins 1 and 2 on SW-1). When making a connection to these pins, make sure that the wire is attached and soldered to **both** pins.

In numerous places throughout this booklet, reference will be made to "Heavy" colored wire. This wire is identical to regular hook-up wire (see page 8) but is thicker and of heavier weight. Use the "Heavy" wire only where specified.

1.  Connect a 3 $\frac{3}{4}$ " Blue/White wire from pin 1 (bottom), P1 to pin 3, SS-1 (S1).
2.  Connect a 3" Blue wire from pin 5 (top), P1 to pin 6, SS-1 (S1).
3.  Strip off an additional  $\frac{1}{2}$ " of insulation from a 2 $\frac{1}{2}$ " Black wire. Pass this stripped end thru pin 2 (bottom), P1\* and connect it to pin 6 (top), P1. Connect the other end to pin 1, P2.

4.  Connect a 2" Black wire from pin 1, P2 (S2) to pin 3, P2.
5.  Connect a 6 $\frac{1}{2}$ " Green wire from pin 4 (bottom), P1 to pin 2 (bottom), P3.
6.  Connect a 6 $\frac{1}{2}$ " Green/White wire from pin 8 (top), P1 to pin 6 (top), P3.
7.  Connect a 3 $\frac{1}{2}$ " ~~Orange/White~~ <sup>GREEN</sup> wire from pin 2, SS-4 (S1) to pin 2, SW-1.
8.  Connect a 3" Orange wire from pin 5, SS-4 (S1) to pin 1, SW-1.
9.  Connect a 5" Yellow/White wire from pin 1, SS-5 to pin 5, SW-2 (S1).
10.  Connect a 4 $\frac{1}{2}$ " Yellow wire from pin 4, SS-5 to pin 11, SW-2 (S1).
11.  Connect one of the bare wires coming from the Pilot Light to ground lug "A", T4A (S1). Ground lug "A" is the hole on the mounting foot portion of the terminal strip. Making sure that the two wires do not cross, connect the remaining wire to pin 3, T4A.
12.  Connect a buss (bare)\*\* wire from pin 3, SS-3 to pin 6, SS-3.

\*When a wire passes through one pin and connects to another, it counts as two connections to the pin it passes through when it comes time to solder this pin.

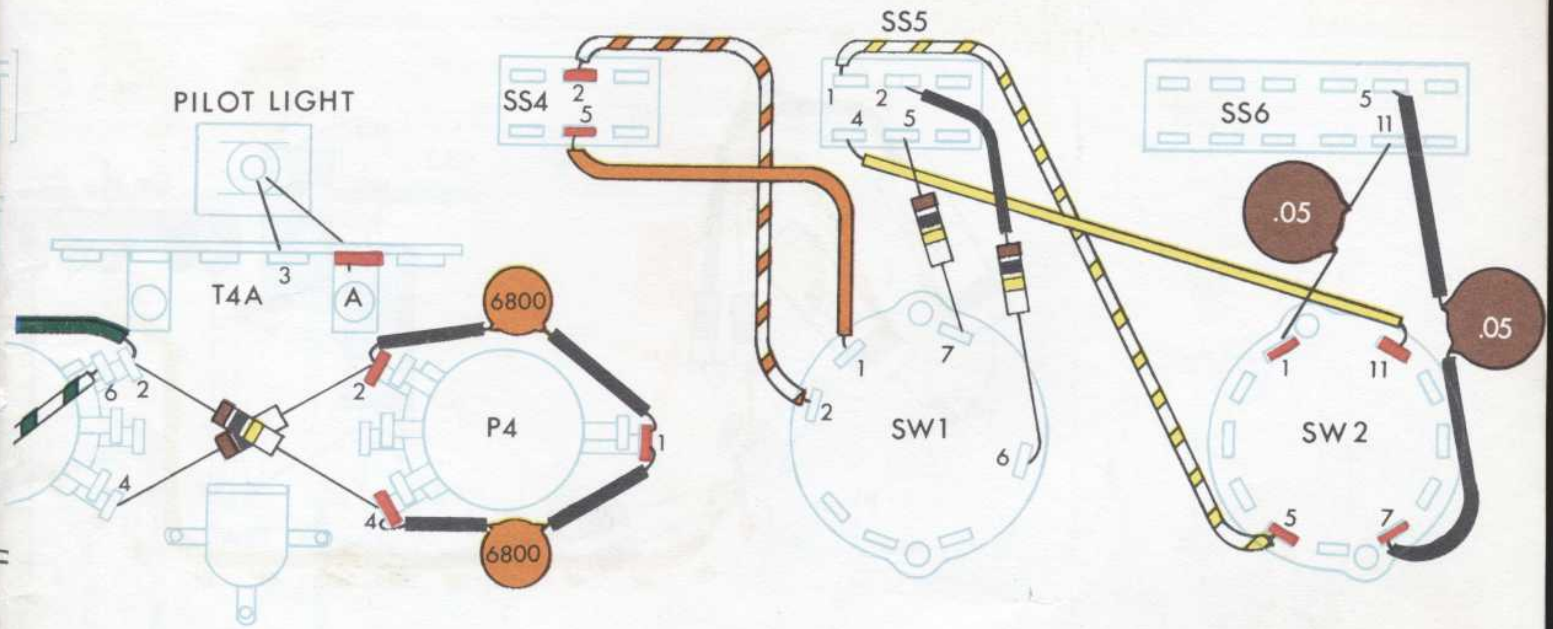

## ASSEMBLY GROUP BF-2

Part-Chart BF-2 contains the components needed for this step. Be sure that uninsulated wires do not touch the metal control covers, the metal chassis, or other uninsulated wires or terminals.

1.  Add a 1½" piece of spaghetti\*\* to each end of a CC-.05. Connect this capacitor from pin 5, SS-6 to pin 7, SW-2 (S1).
2.  Connect a CC-.05 from pin 11, SS-6 to pin 1, SW-2 (S1).
3.  Add a 1" piece of spaghetti to one end of a 100K resistor (Brown, Black, Yellow). Connect this end to pin 2, SS-5. Connect the other end to pin 6, SW-1.
4.  Connect a 100K resistor (Brown, Black, Yellow) from pin 5, SS-5 to pin 7, SW-1.
5.  Add a ½" piece of spaghetti to each end of a CC-6800. Connect the capacitor from pin 1 (bottom), P4 to pin 2 (bottom), P4.
6.  Add a ½" piece of spaghetti to each end of a CC-6800. Connect the capacitor from pin 1 (bottom), P4 (S2) to pin 4 (bottom), P4.
7.  Connect a 100K resistor (Brown, Black, Yellow) from pin 4 (bottom), P3 to pin 2 (bottom), P4 (S2).
8.  Connect a 100K resistor (Brown, Black, Yellow) from pin 2 (bottom), P3 to pin 4 (bottom), P4 (S2).
9.  Add a 1" piece of spaghetti to each end of a CM-47. Connect the capacitor from pin 1, SS-1 (S1) to pin 4 (bottom), P1 (S2).
10.  Add a 1" piece of spaghetti to one end of a CM-47. Connect this end to pin 8 (top), P1 (S2). Connect the other end to pin 4, SS-1 (S1).

\*\*See page 8 for a description of this item.

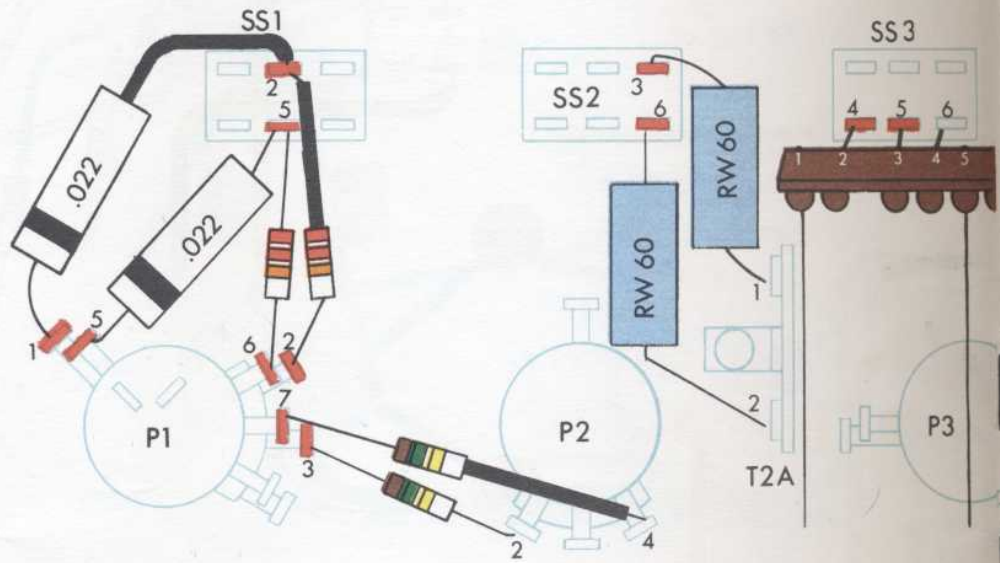

## ASSEMBLY GROUP BF-3

1.  Connect the banded end of a CPM-.022 to pin 1 (bottom), P1 (S2). Add a 1" piece of spaghetti to the other end and connect this end to pin 2, SS-1.
2.  Connect the banded end of a CPM-.022 to pin 5 (top), P1 (S2). Connect the other end to pin 5, SS-1.
3.  Add a 1/2" piece of spaghetti to one end of a 22K resistor (Red, Red, Orange). Connect this end to pin 2, SS-1 (S2). Connect the other end to pin 2 (bottom), P1 (S3).
4.  Connect a 22K resistor (Red, Red, Orange) from pin 5, SS-1 (S2) to pin 6 (top), P1 (S2).
5.  Connect a 150K resistor (Brown, Green, Yellow) from pin 3 (bottom), P1 (S1) to pin 2, P2.

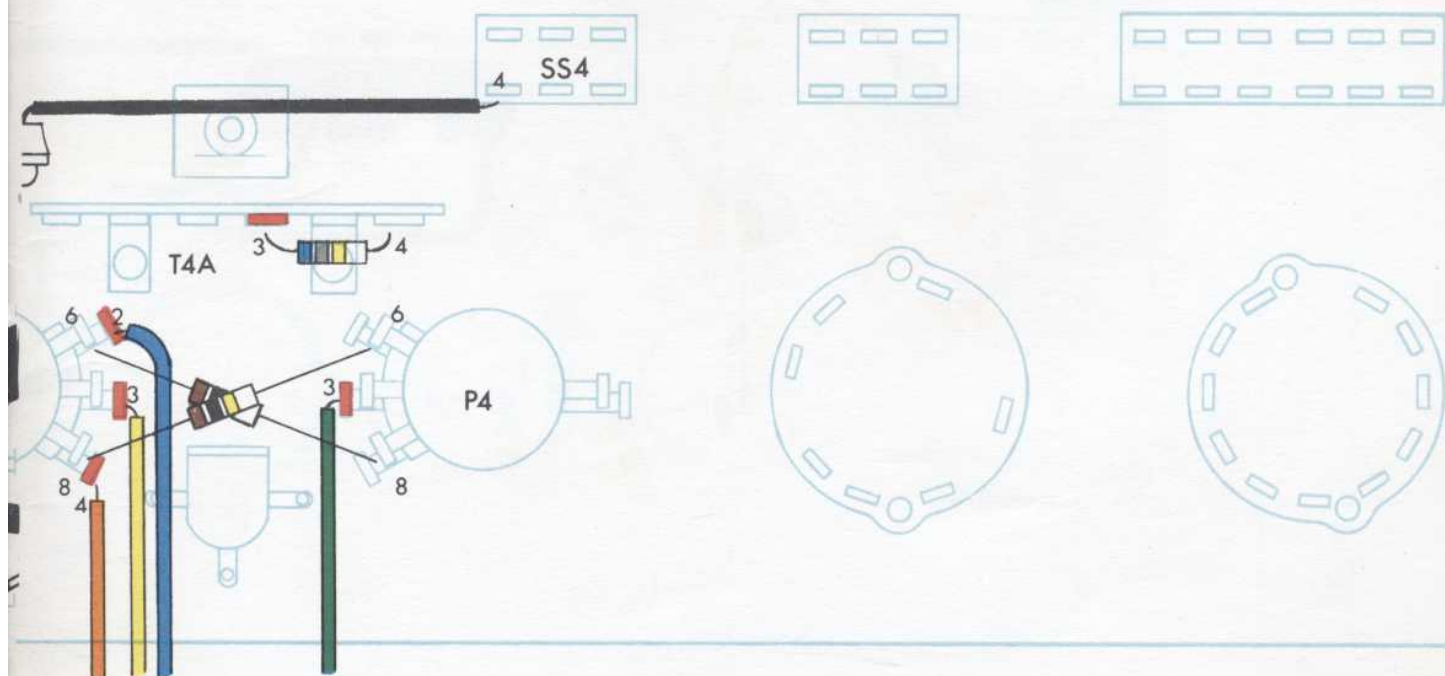

6.  Add a  $\frac{3}{4}$ " piece of spaghetti to one end of a 150K resistor (Brown, Green, Yellow). Connect this end to pin 4, P2. Connect the other end to pin 7 (top), P1 (S1).
7.  Connect an RW-60 from pin 6, SS-2 (S1) to pin 2, T2A.
8.  Connect an RW-60 from pin 3, SS-2 (S1) to pin 1, T2A.
9.  Bend downward lead 1 and lead 5 of the large PEC-299. Bend leads 2, 3 and 4 upward and lead 6 out to the side. Position the PEC as close to SS-3 as you can and connect lead 2 to Pin 4, SS-3 (S1). Connect lead 3 to Pin 5, SS-3 (S1), and lead 4 to Pin 6, SS-3. Add a  $2\frac{1}{2}$ " piece of spaghetti to lead 6 and connect it to Pin 4, SS-4. Leads 1 and 5 will be connected later.
10.  Connect a 680K resistor (Blue, Grey, Yellow) from pin 3, T4A (S2) to pin 4, T4A.
11.  Connect one end of a 6" Green wire to pin 3 (bottom), P4 (S1). Do not yet connect the other end.
12.  Connect one end of a 6" Blue wire to pin 2 (bottom), P3 (S3).
13.  Connect one end of a  $7\frac{1}{2}$ " Yellow wire to pin 3 (bottom), P3 (S1).
14.  Connect one end of a 6" Orange wire to pin 4 (bottom), P3 (S2).
15.  Connect a 100K resistor (Brown, Black, Yellow) from pin 6 (top), P3 to pin 8 (top), P4.
16.  Connect a 100K resistor (Brown, Black, Yellow) from pin 8 (top), P3 to pin 6 (top), P4.

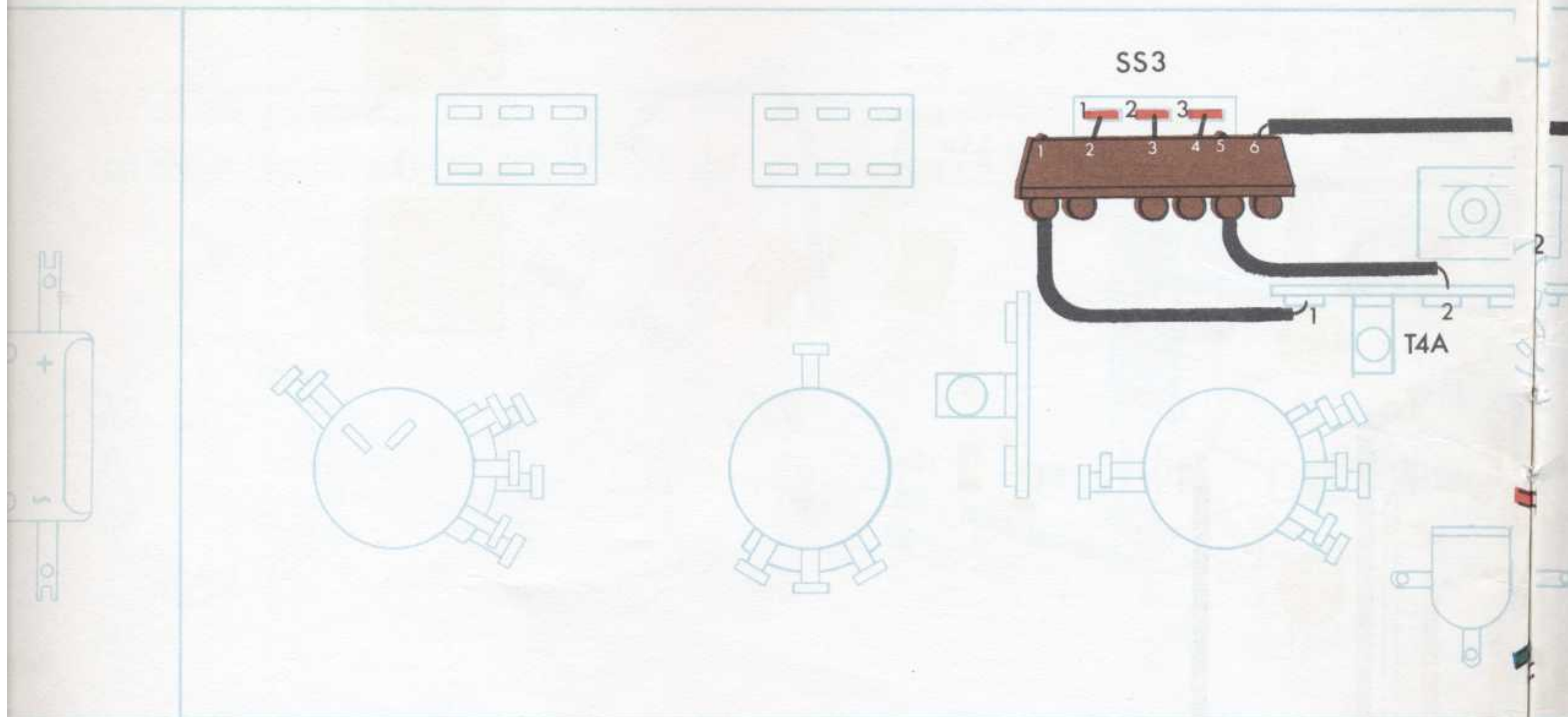

## ASSEMBLY GROUP BF-4

1.  Bend down and backward lead 1 and lead 5 of the large PEC-299. Bend leads 2, 3 and 4 upward and lead 6 out to the side. Position the PEC as close to SS-3 as you can and connect lead 2 to Pin 1, SS-3 (S1), lead 3 to pin 2, SS-3 (S1) and lead 4 to pin 3, SS-3 (S2). Add a 1½" piece of spaghetti to lead 1 and connect the lead to Pin 1, T4A. Add a 1¼" piece of spaghetti to lead 5 and connect the lead to Pin 2, T4A. Add a 2½" piece of spaghetti to lead 6 and connect the lead to Pin 1, SS-4.
2.  Connect the banded end of a CPM-.0033 to pin 1, SS-4 (S2). Connect the other end to pin 3, SS-4 (S1).
3.  Connect the banded end of a CPM-.0033 to pin 4, SS-4 (S2). Connect the other end to pin 6, SS-4 (S1).
4.  Add a ½" piece of spaghetti to each end of a CC-6800. Connect the capacitor from pin 5 (top), P4 to pin 6 (top), P4 (S2).

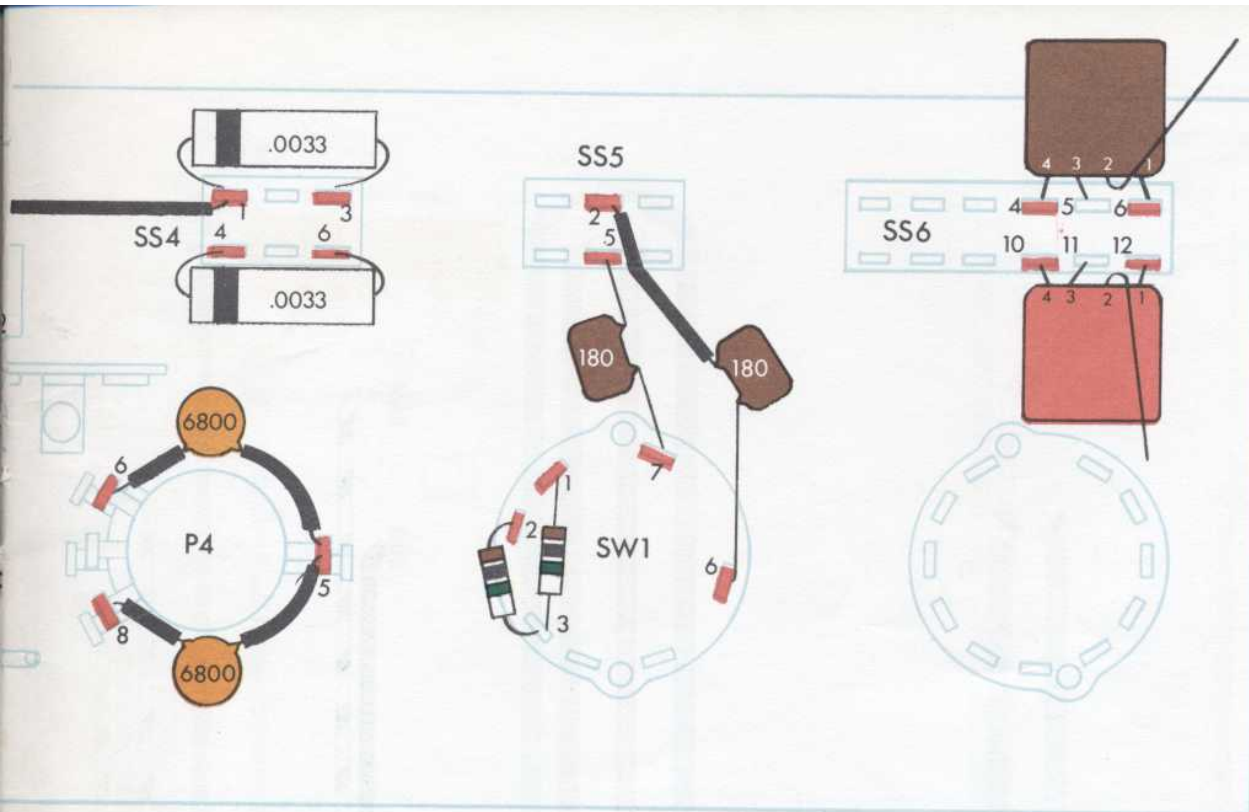

5.  Add a  $\frac{1}{2}$ " piece of spaghetti to each end of a CC-6800. Connect the capacitor from pin 5 (top), P4 (S2) to pin 8 (top), P4 (S2).
6.  Connect a 1M resistor (Brown, Black, Green) from pin 1, SW-1 (S2) to pin 3, SW-1.
7.  Connect a 1M resistor (Brown, Black, Green) from pin 2, SW-1 (S2) to pin 3, SW-1.
8.  Connect a CM-180 from pin 5, SS-5 (S2) to pin 7, SW-1 (S2).
9.  Add a  $\frac{3}{4}$ " piece of spaghetti to one end of a CM-180. Connect this end to pin 2, SS-5 (S2). Connect the other end to pin 6, SW-1 (S2).
10.  Connect lead 4 of the Red PEC-222E to pin 10, SS-6 (S1), lead 3 to pin 11, SS-6, and lead 1 to pin 12, SS-6 (S1). Do not connect lead 2 at this time.
11.  Connect lead 4 of the Brown PEC-222E to pin 4, SS-6 (S1), lead 3 to pin 5, SS-6, and lead 1 to pin 6, SS-6 (S1). Do not connect lead 2 at this time.

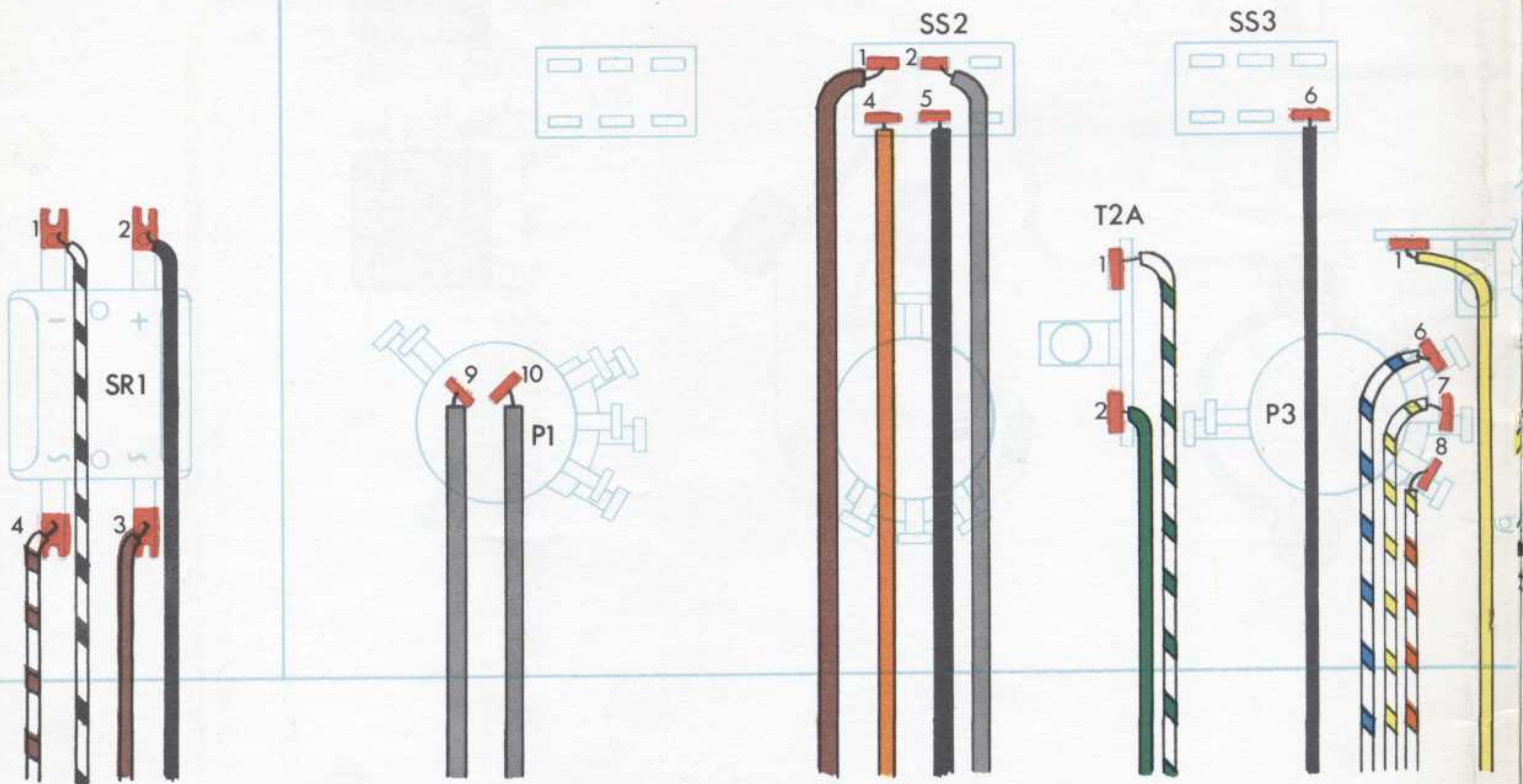

## ASSEMBLY GROUP BF-5

In this step you will connect only one end of all the wires being used. The other ends will be connected later. Note that first use of "Heavy" colored wire is in this step.

1.  Connect a 7½" Blue wire to pin 5, SS-6 (S3).
2.  Connect a 6" Blue/White wire to pin 11, SS-6 (S3).
3.  Connect a 7½" Green wire to pin 2, SS-6 (S1).
4.  Connect a 5" Green/White wire to pin 8, SS-6 (S1).
5.  Connect a 6" Orange wire to pin 10, SW-2 (S1).
6.  Connect a 4½" Green/White wire to pin 7 (top), P4 (S1).
7.  Connect a 5" Blue/White wire to pin 6 (top), P3 (S3).
8.  Connect a 4½" Yellow/White wire to pin 7 (top), P3 (S1).
9.  Connect a 3" Orange/White wire to pin 8 (top), P3 (S2).
10.  Connect a 4" Red wire to pin 4, T4A (S2).
11.  Clip out the bare wire at one end of a 6½" Orange mic lapel\*. Connect the insulated wire at this end to pin 2, T4A (S2).
12.  Connect a 6½" Yellow wire to pin 1, T4A (S2).
13.  Connect a 5½" Green wire to pin 2, T2A (S2).

\*See page 8 for a description of this wire

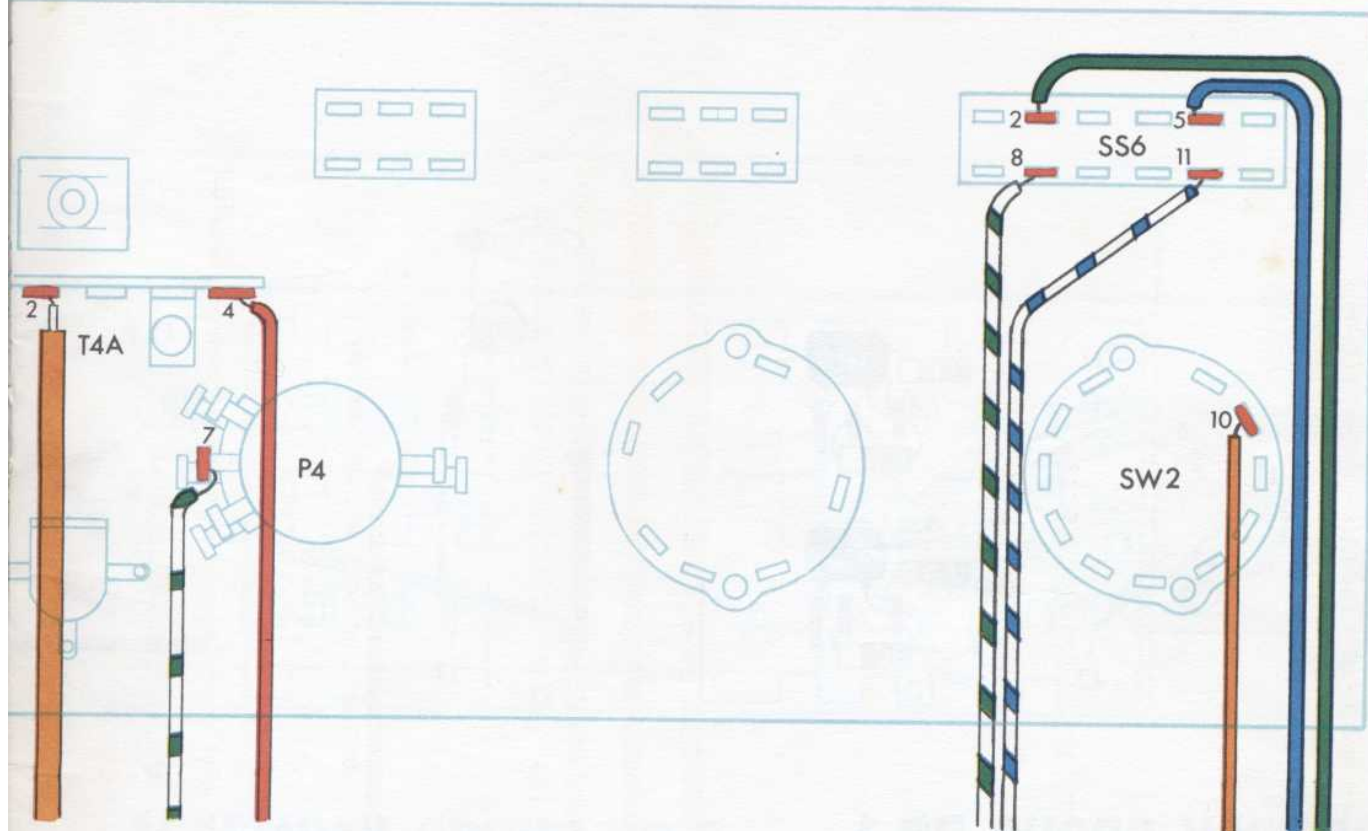

14.  Connect a 3" Green/White wire to pin 1, T2A (S2).
15.  Connect a 6½" <sup>GREEN</sup> Black wire to pin 6, SS-3 (S3).
16.  Connect an 11" Heavy Black wire to pin 5, SS-2 (S1).
17.  Connect a 14½" Heavy Orange wire to pin 4, SS-2 (S1).
18.  Connect a 16" Heavy Brown wire to pin 1, SS-2 (S1).
19.  Connect a 17½" Heavy Grey wire to pin 2, SS-2 (S1).
20.  Connect a 12½" Heavy Grey wire to pin 9, P1 (S1).
21.  Connect a 14¾" Heavy Grey wire to pin 10, P1 (S1).
22.  Connect an 8" Black/White wire to pin 1, SR-1 (S1).
23.  Connect a 9¾" Black wire to pin 2, SR-1 (S1).
24.  Connect an 8½" Brown wire to pin 3, SR-1 (S1).
25.  Connect an 8½" Brown/White wire to pin 4, SR-1 (S1).

You have now completed most of the electrical assembly on the front. It is now time to check your work. Refer to Chart AF-1 and follow the instructions on Page 54 concerning the Double-Check system. **At this time, refer only to the numbers that are not circled.** A circled number indicates that more connections will be made to this pin.



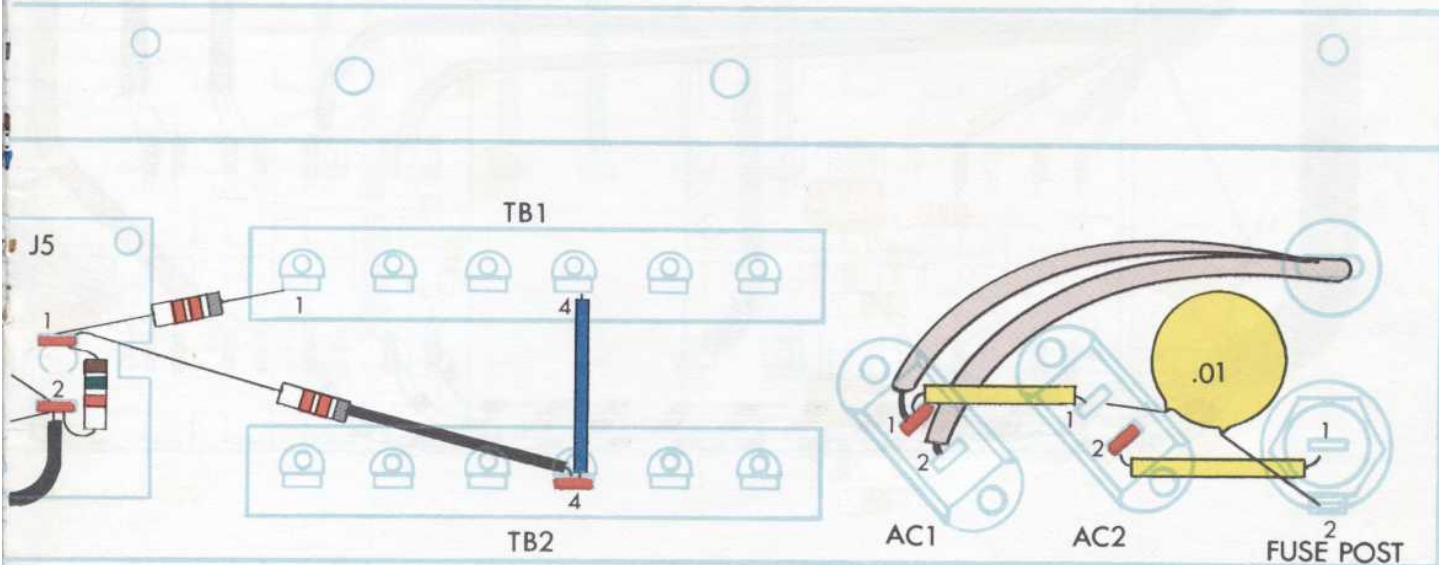

## ASSEMBLY GROUP BR-2

1.  Connect one end of a CC-.001 to L2 (S1). Pass the other end thru pin 1, J3 (S2)\* and connect it to pin 1, J4.
2.  Connect a 2.2M resistor (Red, Red, Green) from pin 8, J3 to pin 2, J5.
3.  Connect a 2.2M resistor (Red, Red, Green) from pin 8, J4 to pin 2, J5.
4.  Connect a 1.5K resistor (Brown, Green, Red), from pin 1, J5 to pin 2, J5 (S4).
5.  Connect an 8.2K (Grey, Red, Red) from pin 1, J5 to pin 1, TB-1.
6.  Add a 1" piece of spaghetti to one end of an 8.2K resistor (Grey, Red, Red). Connect this end to pin 4, TB-2 (S2). Connect the other end to pin 1, J5 (S3).
7.  Connect a CC-.01 from pin 1, AC-2 to pin 2 on the Fuse Post.

\*A wire passing through a pin counts as two connections to that pin when it is soldered.

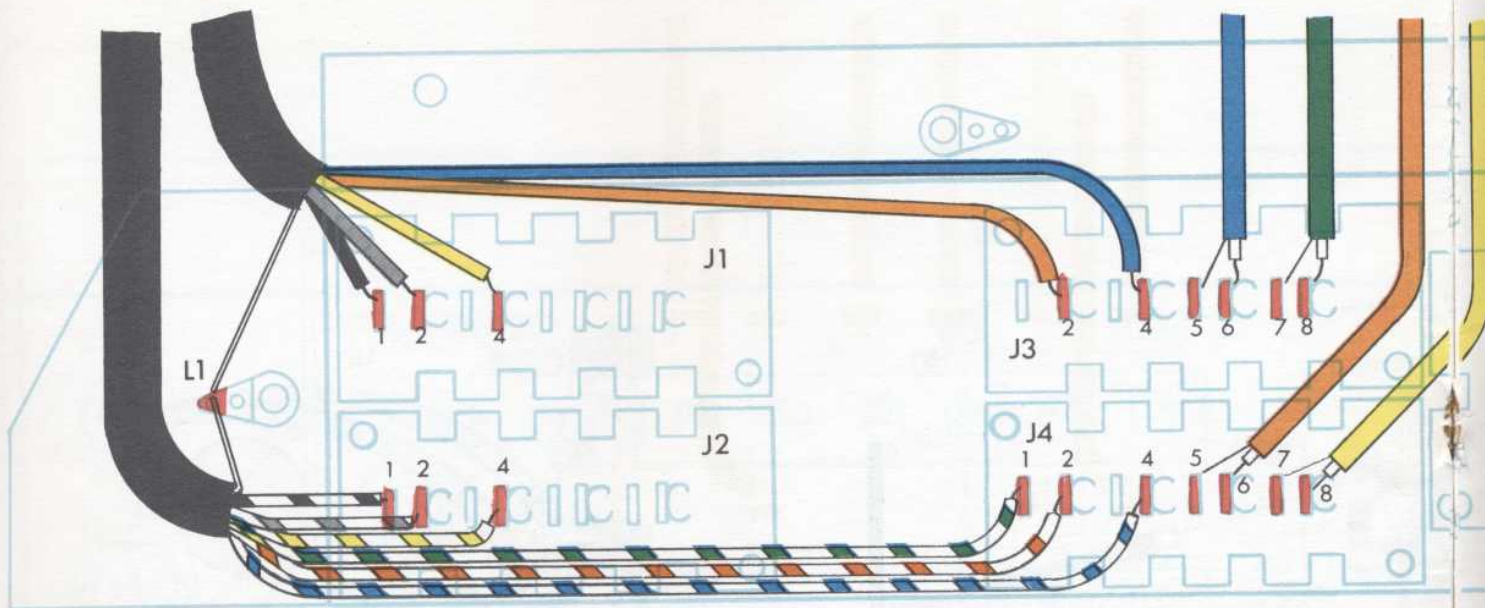

## ASSEMBLY GROUP BR-3

All the wires assembled in the next steps will be connected at one end only. The other end will be connected later.

1.  Connect a 16½" Blue wire to pin 4, J3 (S1).
2.  Connect a 16" <sup>Green</sup> ~~Orange~~ wire to pin 2, J3 (S1).
3.  Connect a 17½" Yellow wire to pin 4, J1 (S2).
4.  Connect a 17" Grey wire to pin 2, J1 (S1).
5.  Connect a 21½" Black wire to pin 1, J1 (S2).
6.  At one end of a 10" Black ESS conductive cable\*, unwrap about 1" of the metal shield. Insert a small nylon sleeve into the cable at this end. (See Fig. 6). Place this end of the cable over the wires so that the nylon sleeve is towards the rear chassis. Connect the metal shield to L1. Slide another nylon sleeve over the wires at the other end and push it into the cable. Bend the wires slightly to hold the sleeve in place.
7.  Connect an 18½" Blue/White wire to pin 4, J4 (S1).
8.  Connect a 19" Orange/White wire to pin 2, J4 (S1).
9.  Connect an 18" Green/White wire to pin 1, J4 (S2).

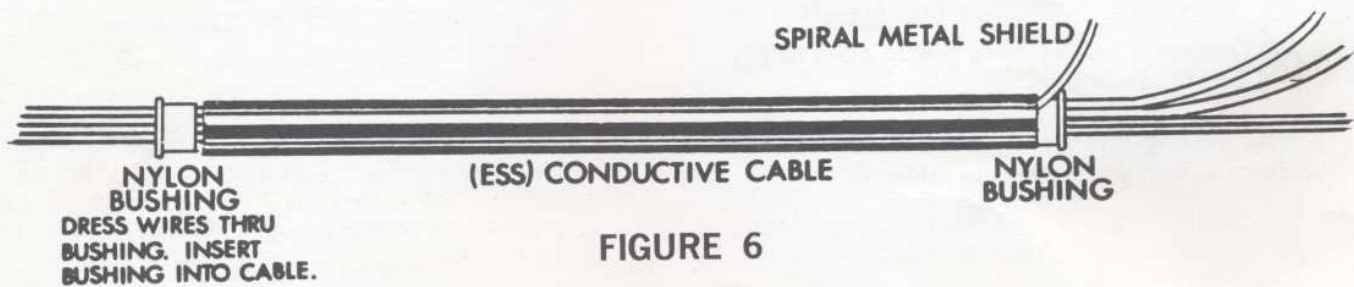

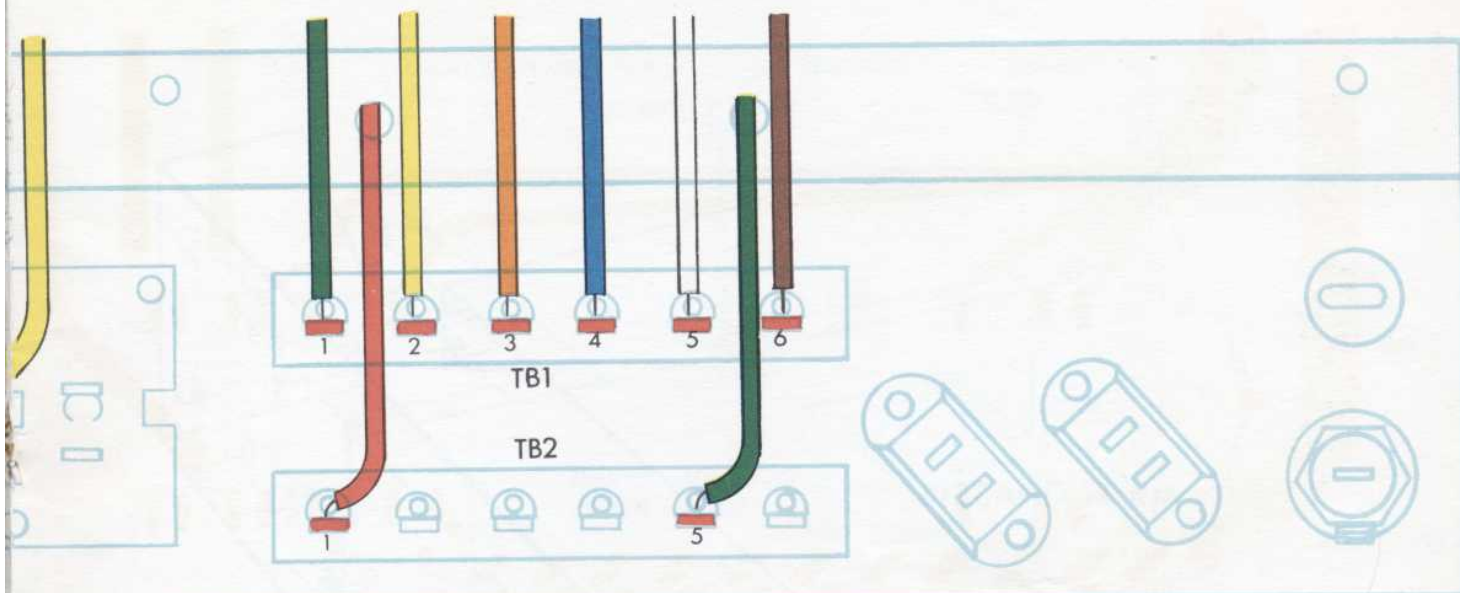

10.  Connect a 15½" Yellow/White wire to pin 4, J2 (S2).
11.  Connect a 16½" Grey/White wire to pin 2, J2 (S1).
12.  Connect a 20½" Black/White wire to pin 1, J2 (S2).
13.  Repeat the procedure used in step 6 for assembling another 10" Black ESS cable. Connect the pulled-out shield to L1 (S4).
14.  Connect the insulated wire of a 14½" Green mic lapel\* to pin 8, J3 (S2). Connect the bare wire at this end to pin 7, J3 (S1).
15.  Connect the insulated wire of a 14½" Blue mic lapel to pin 6, J3 (S1). Connect the bare wire at this end to pin 5, J3 (S1).
16.  Connect the insulated wire of a 14" Yellow mic lapel to pin 8, J4 (S2). Connect the bare wire at this end to pin 7, J4 (S2).
17.  Connect the insulated wire of a 14" Orange mic lapel to pin 6, J4 (S1). Connect the bare wire at this end to pin 5, J4 (S1).
18.  Connect one end of a 6" Heavy Red wire to pin 1, TB-2 (S1). Pass the other end thru grommet #1 but do not connect it.

19.  Connect one end of a 6" Heavy Green wire to pin 5, TB-2 (S1). Pass the other end thru grommet #2 but do not connect it.
20.  Connect a 10½" Heavy Green wire to pin 1, TB-1 (S2).
21.  Connect an 11½" Heavy Yellow wire to pin 2, TB-1 (S1).
22.  Connect a 12½" Heavy Orange wire to pin 3, TB-1 (S1).
23.  Connect a 10" Heavy Blue wire to pin 4, TB-1 (S2).
24.  Connect a 10" Heavy White wire to pin 5, TB-1 (S1).
25.  Connect a 10" Heavy Brown wire to pin 6, TB-1 (S1).

\*See page 8 for a description of this cable.

You have now completed most of the electrical assembly on the rear. Using Chart AR-1 and following the instructions on Page 54, double-check your work. Once again, as on the front, refer only to the numbers that are **not** circled.

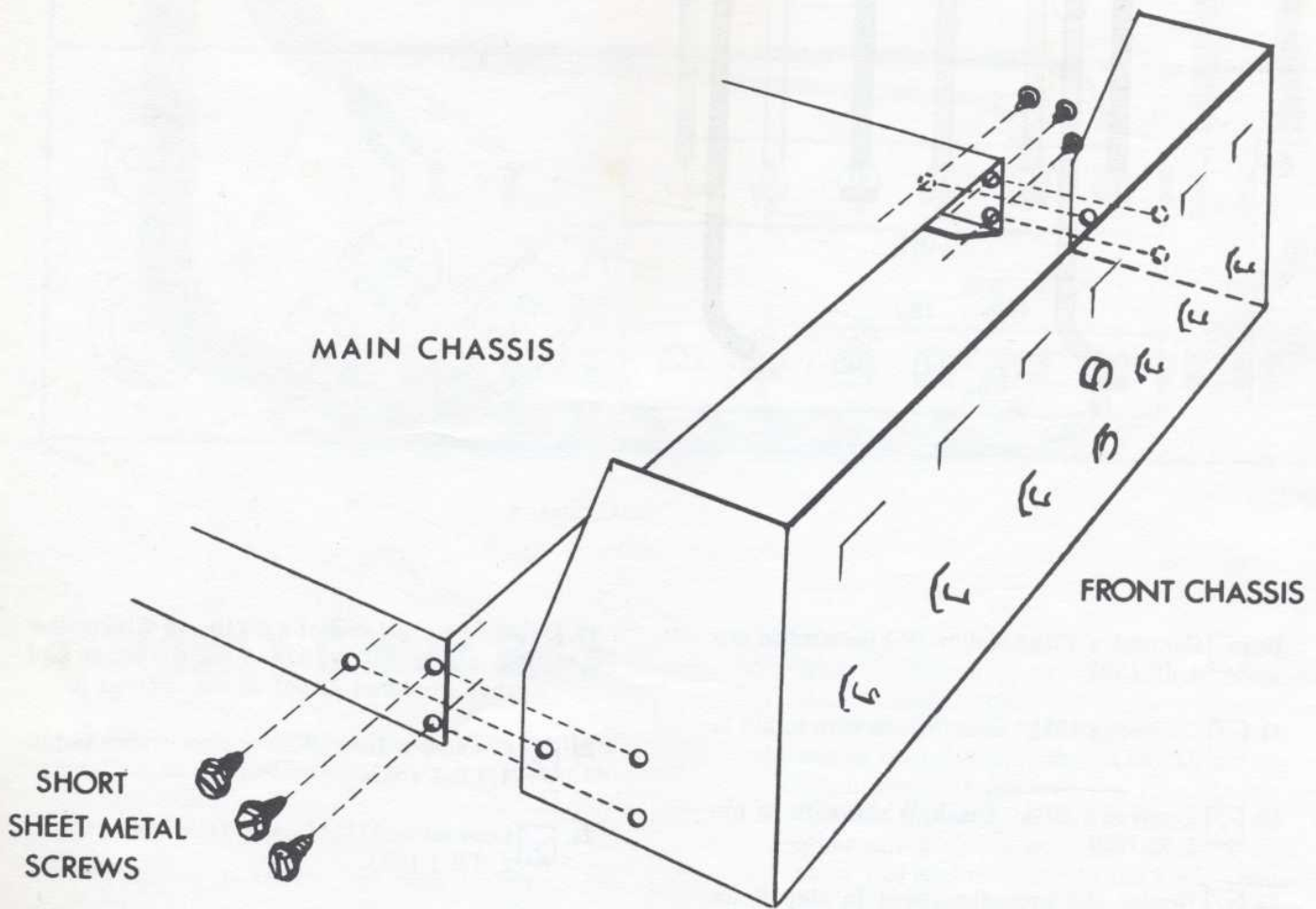

FIGURE 7

## MECHANICAL ASSEMBLY GROUP A-2

1.  Bend all of the wires attached to the front downward, towards the row of pots.
2.  Assemble the front to the main as shown in (Figure 7). Use six of the short  $\frac{1}{4}$ " sheet metal screws to fasten the sections together. Use a fairly good-sized screwdriver and don't be afraid to push down hard on the screws to get them started.
3.  Position the main chassis in front of you with the underside facing up and the back facing you. You will note that there is a shield on the left rear of the main chassis.

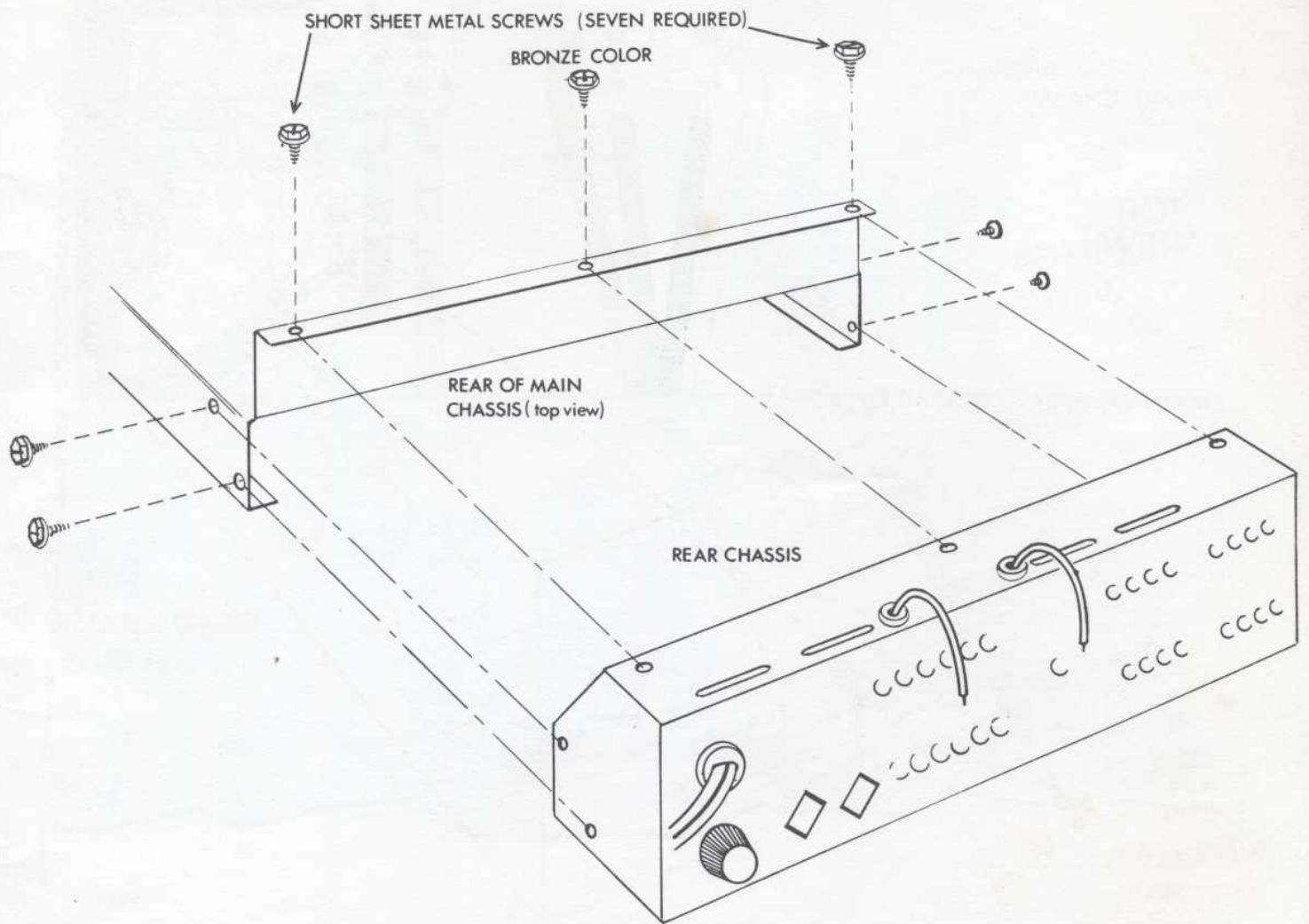

FIGURE 8

Take the two Black cables that are connected to the rear, and feed them through the space to the left of the shield. Position them along the side of the main chassis. Position the Heavy Red and Green wires, that pass through the grommets, towards the outside of the rear chassis. Position all the other wires that are connected to the rear towards the underside of the main. Turn the chassis over and fasten the rear to the main with six of the short  $\frac{1}{4}$ " sheet metal screws and one short Bronze sheet metal screw. The Bronze screw is to be inserted in the middle hole on the top of the rear chassis. (See Figure 8).

FRONT CHASSIS

TOP  
VIEW

MAIN CHASSIS

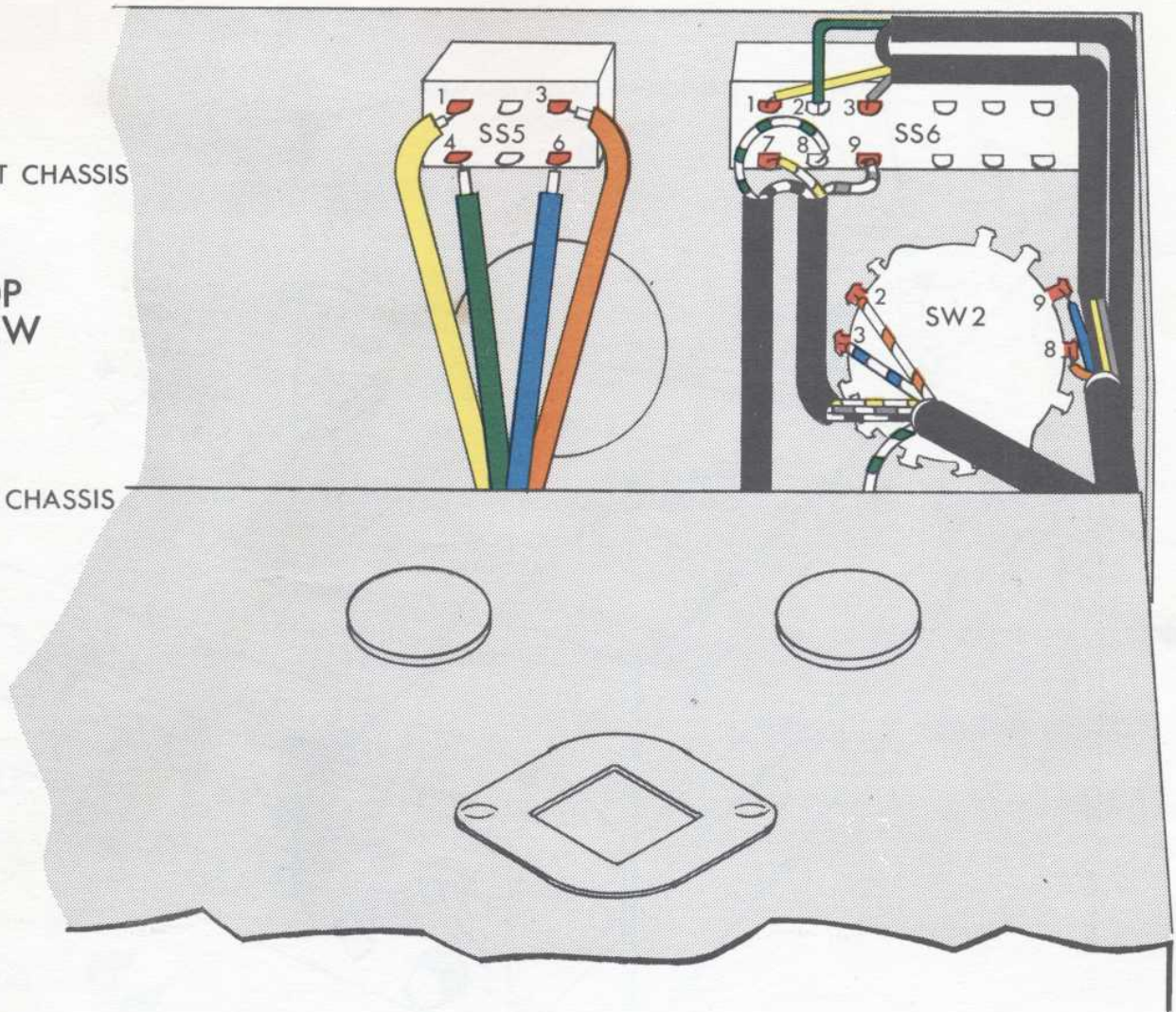

## ASSEMBLY GROUP BM-1

The next two steps are somewhat complex. Proceed slowly and carefully. Be sure to position all cables as shown in above diagrams!

Position the chassis in front of you, right side up, and with the rear facing you.

1.  Connect the Blue Wire coming from the Black cable containing the solid colored wires (Blue, Grey, Yellow, etc.) to pin 9, SW-2 (S1). Connect the Orange wire to pin 8, SW-2 (S1). Place a 3" piece of Heavy Black Insulation\* over the Yellow, Black and Grey wires. Connect the Yellow wire to pin 1, SS-6 (S1), and the Grey wire to pin 3, SS-6 (S1). Select the Black wire coming from the cable and the Green wire coming from pin 2, SS-6. Add a 3½" piece of Heavy Black Insulation to these two wires. Turn the chassis over and connect the Black wire to pin 3, T6A on the main. Connect the Green wire to pin 2, T6A. SEE BOTTOM VIEW FOR THE CONNECTIONS THAT ARE MADE TO THE MAIN CHASSIS.

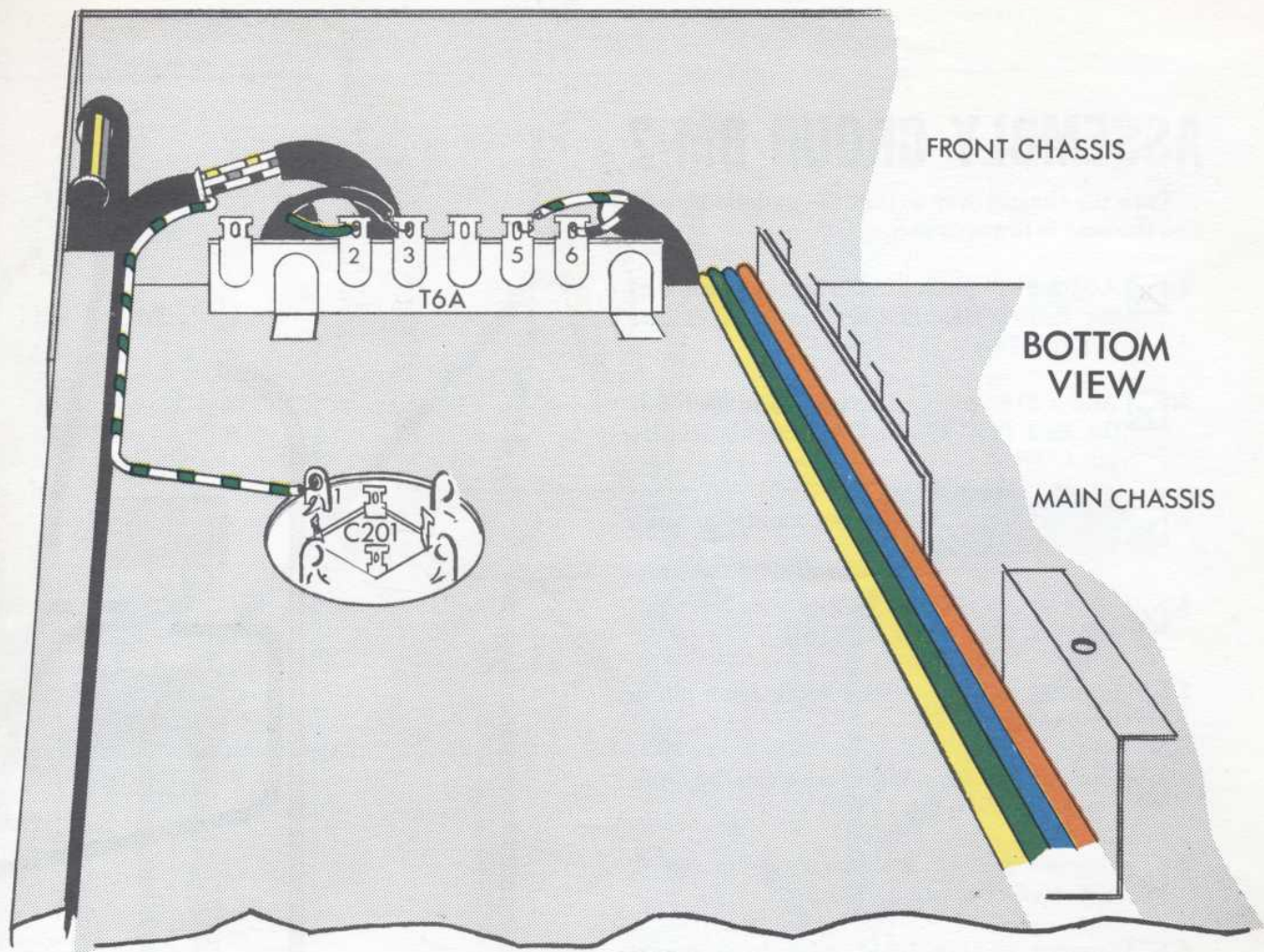

2.  Connect the Blue/White wire coming from the *second* Black cable to pin 3, SW-2 (S1). Connect the Orange/White wire to pin 2, SW-2 (S1). Place a 3" piece of Heavy Black Insulation over the Yellow/White, Grey/White and Black/White wires. Connect the Yellow/White wire to pin 7, SS-6 (S1) and the Grey/White wire to pin 9, SS-6 (S1). Select the Black/White wire coming from the cable and the Green/White wire coming from pin 8, SS-6. Add a 3" piece of Heavy Black Insulation to these two wires. Turn the chassis over and connect the Green/White wire to pin 5, T6A on the main. Connect the Black/White wire to pin 6, T6A. There is a Green/White wire coming from this second cable that has not been connected. Connect it now to pin 1, C201, on the main. SEE BOTTOM VIEW.

- 3.  Turn the chassis over again so that the top is up. Clip out the bare wire of the Green mic lapel coming from the rear. Connect the insulated wire to pin 4, SS-5 (S2).
- 4.  Clip out the bare wire of the Blue mic lapel coming from the rear. Connect the insulated wire to pin 6, SS-5 (S1).
- 5.  Clip out the bare wire of the Yellow mic lapel. Connect the insulated wire to pin 1, SS-5 (S2).
- 6.  Clip out the bare wire of the Orange mic lapel. Connect the insulated wire to pin 3, SS-5 (S1).

\*See Page 8 for a description of this item.

## ASSEMBLY GROUP BM-2

Turn the chassis over so that the underside is up and the rear is towards you.

1.  Add a 3½" piece of spaghetti to lead 2 of the Brown PEC-222-E. Connect this lead to pin 1, T6A.
2.  Add a 3½" piece of spaghetti to lead 2 of the Red PEC-222-E. Connect this lead to pin 4, T6A.
3.  Connect the Orange wire coming from pin 10, SW-2 to pin 7, V1.
4.  Connect a 6" Orange/White wire from pin 4, SW-2 (S1) to pin 7, V101.
5.  Connect the Blue wire coming from pin 5, SS-6 to pin 1, T2B.
6.  Connect the Blue/White wire coming from pin 11, SS-6 to pin 1, T6B.
7.  Connect a 2½" Black wire from pin 6, SW-2 (S1) to pin 3, T6A.
8.  Connect a 2½" Black wire from pin 3, SW-1 (S3) to pin 6, T6A.
9.  Connect the Red wire coming from pin 4, T4A to pin 3, T6C.
10.  Connect the insulated wire of the Orange mic lapel coming from pin 2, T4A to pin 5, T6B. Connect the bare wire at this end to lug "A" T6B (S1).
11.  Connect the Yellow wire coming from pin 1, T4A to pin 6, T6C.
12.  Connect the Green wire coming from pin 3 (bottom), P4 to pin 4, T6B.
13.  Connect the Green/White wire coming from pin 7 (top), P4 to pin 3, T5A.
14.  Add a 2½" piece of spaghetti to lead 5 of PEC-299. Connect this lead to pin 2, T5A.
15.  Add a 2½" piece of spaghetti to lead 1 of PEC-299. Connect this lead to pin 1, T5A.

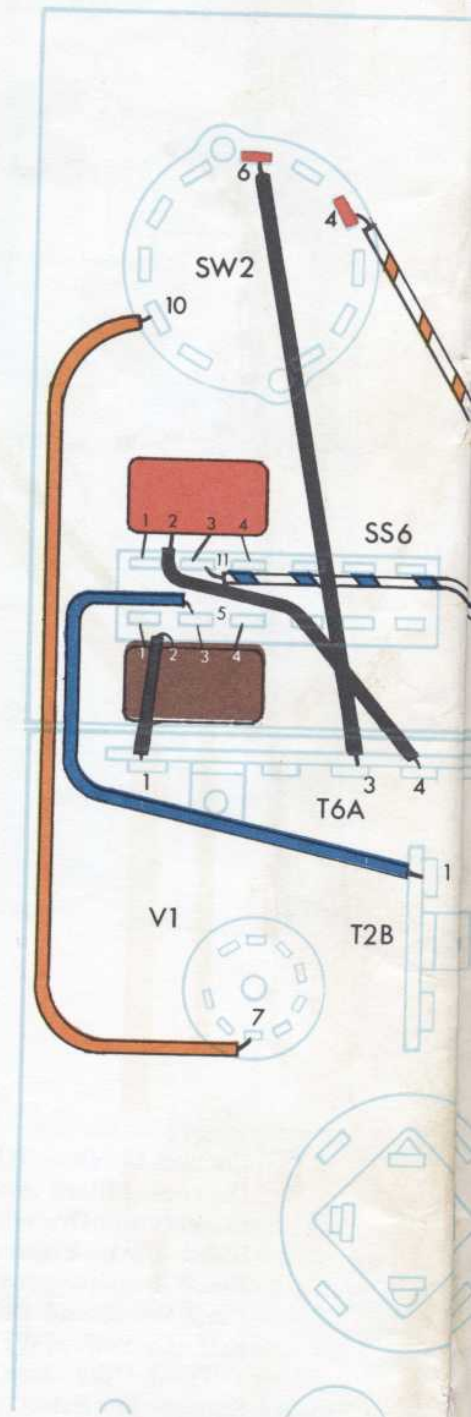

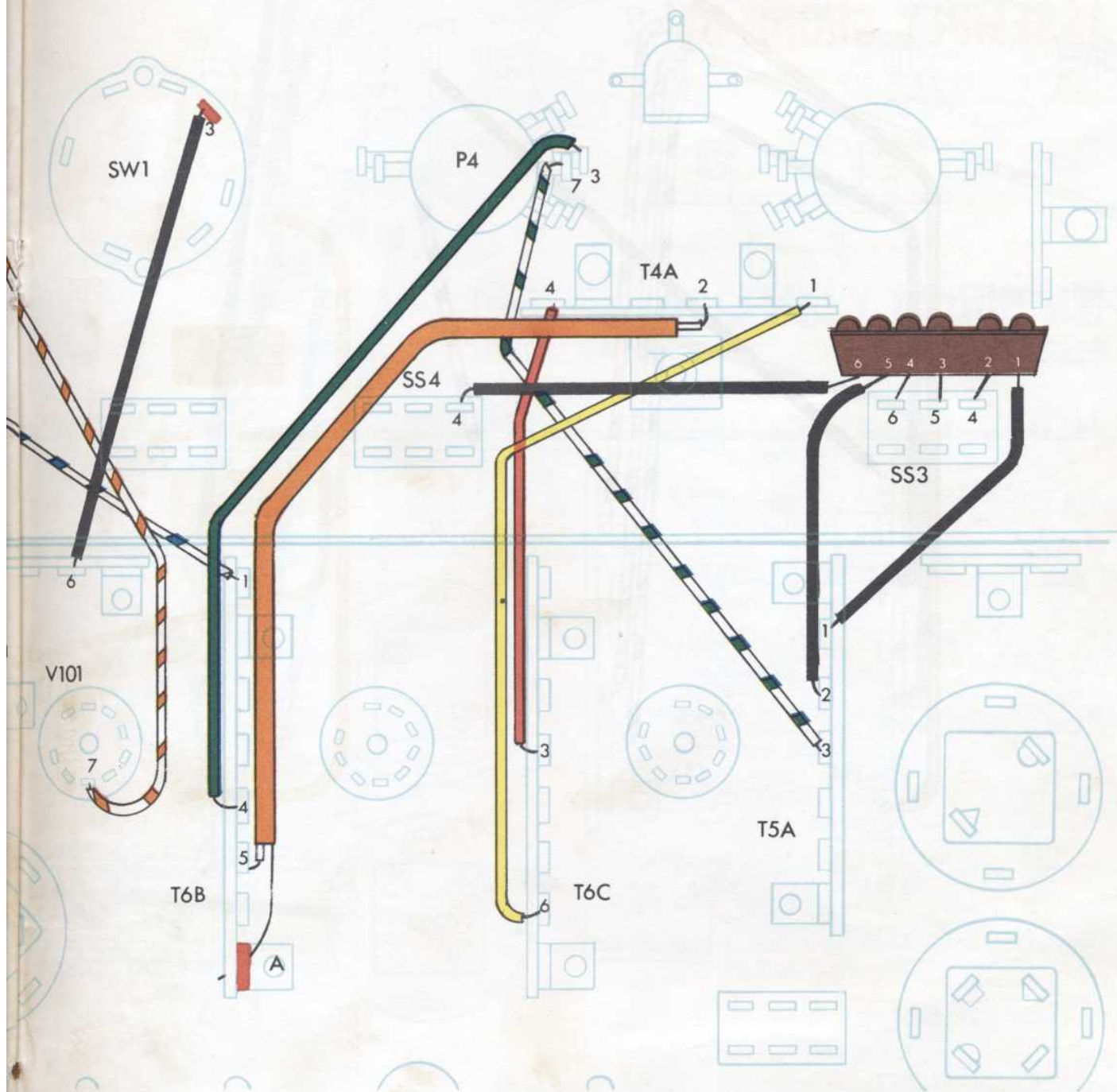

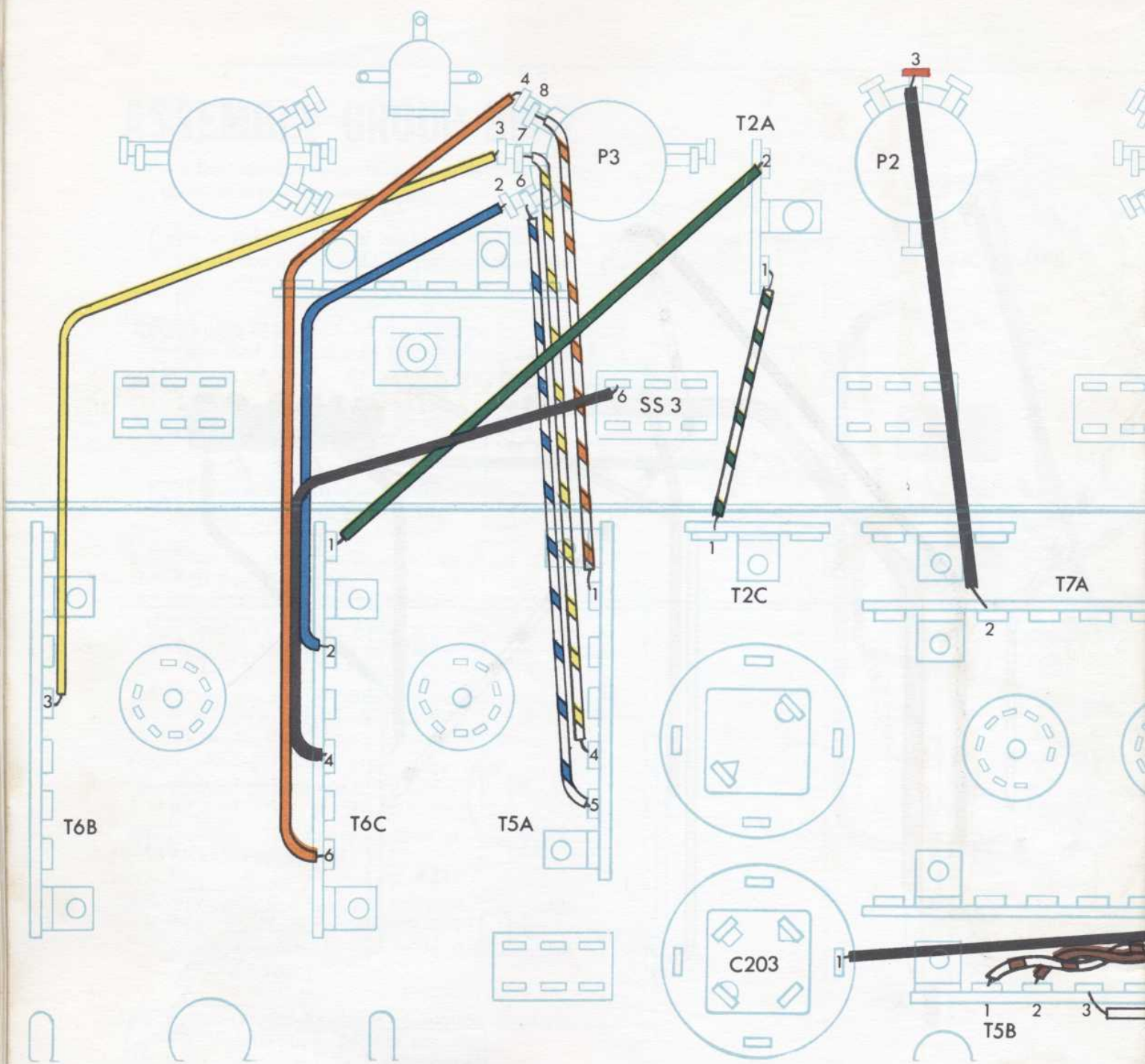

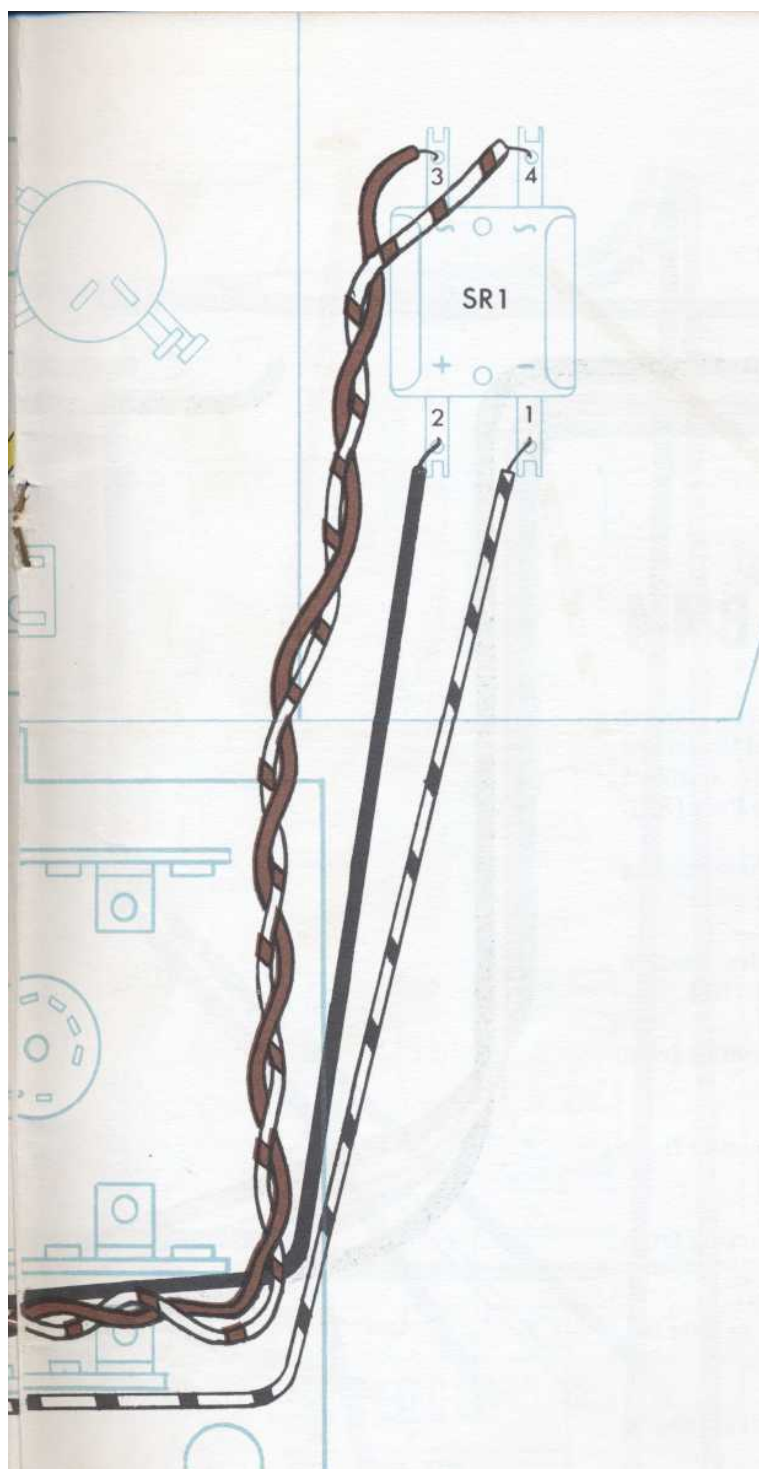

## ASSEMBLY GROUP BM-3

1.  Connect the Blue wire coming from pin 2 (bottom), P3 to pin 2, T6C.
2.  Connect the Yellow wire coming from pin 3 (bottom), P3 to pin 3, T6B.
3.  Connect the Orange wire coming from pin 4 (bottom), P3 to pin 6, T6C.
4.  Connect the Blue/White wire coming from pin 6 (top), P3 to pin 5, T5A.
5.  Connect the Yellow/White wire coming from pin 7 (top), P3 to pin 4, T5A.
6.  Connect the Orange/White wire coming from pin 8 (top), P3 to pin 1, T5A.
7.  Connect the <sup>GREEN</sup>Black wire coming from pin 6, SS-3 to pin 4, T6C.
8.  Connect the Green/White wire coming from pin 1, T2A to pin 1, T2C.
9.  Connect the Green wire coming from pin 2, T2A to pin 1, T6C.
10.  Connect a 2½" Black wire from pin 3, P2 (S2) to pin 2, T7A.
11.  Connect the Black wire coming from pin 2, SR-1 to pin 1, C203.
12.  Connect the Black/White wire coming from pin 1, SR-1 to pin 3, T5B.
13.  Twist together the Brown and Brown/White wires coming from SR-1. Connect the Brown/White wire to pin 1, T5B and the Brown wire to pin 2, T5B.

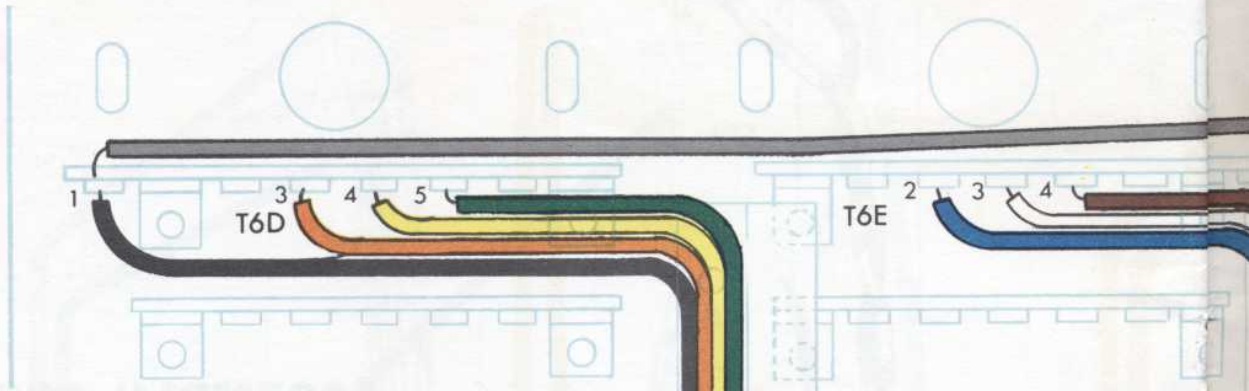

## ASSEMBLY GROUP BM-4

1.  Twist the two Heavy Grey wires coming from P1 **tightly** together. Connect the longer of the two to pin 2, AC-1 (S2). Connect the other one to pin 1 on the Fuse Post (S2).
2.  Connect the Heavy Brown wire coming from pin 1, SS-2 to pin 2, TB-2 (S1).
3.  Connect the Heavy Orange wire coming from pin 4, SS-2 to pin 6, TB-2 (S1).
4.  Connect the Heavy Grey wire coming from pin 2, SS-2 to pin 1, T6D.
5.  Connect the Heavy Black wire coming from pin 5, SS-2 to pin 6, T6E.
6.  Connect the Heavy Green wire coming from pin 1, TB-1 to pin 5, T6D.
7.  Connect the Heavy Yellow wire coming from pin 2, TB-1 to pin 4, T6D.
8.  Connect the Heavy Orange wire coming from pin 3, TB-1 to pin 3, T6D.
9.  Connect the Heavy Blue wire coming from pin 4, TB-1 to pin 2, T6E.
10.  Connect the Heavy White wire coming from pin 5, TB-1 to pin 3, T6E.
11.  Connect the Heavy Brown wire coming from pin 6, TB-1 to pin 4, T6E.
12.  Connect a 13" Heavy Black wire from pin 3, TB-2 (S1) to pin 1, T6D.

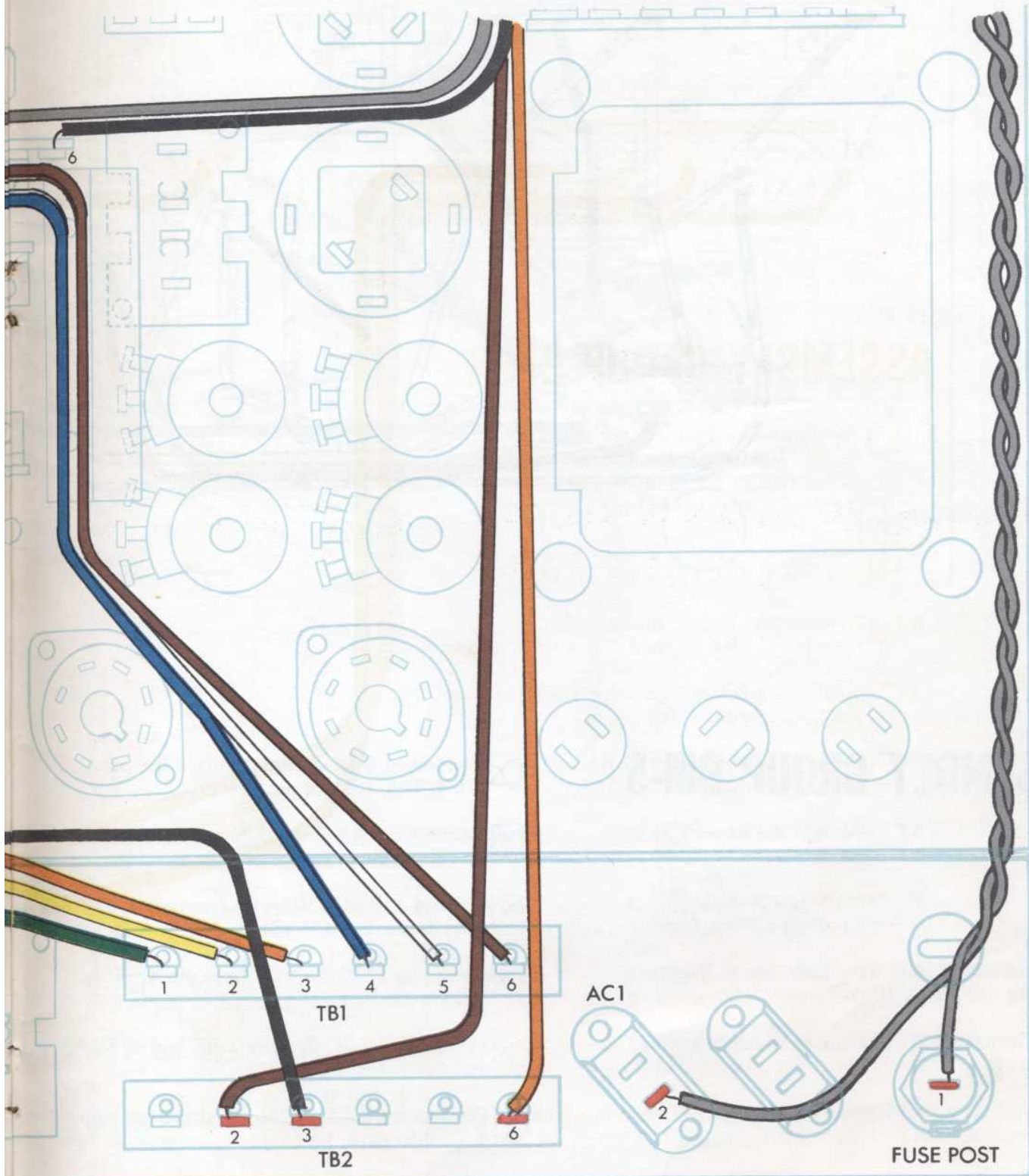

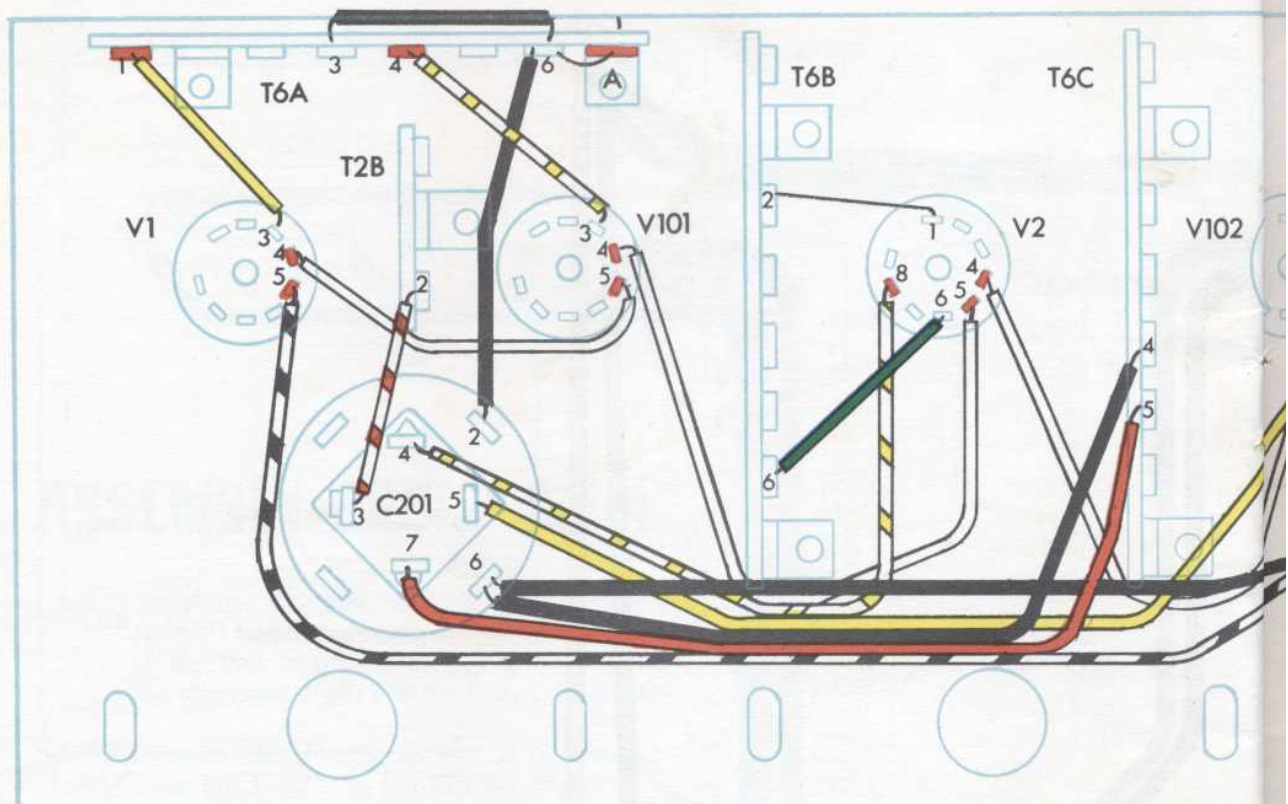

## ASSEMBLY GROUP BM-5

1.  Connect a buss wire from pin 6, T6A to lug "A", T6A (S1).
2.  Connect a 2½" Black wire from pin 3, T6A to pin 6, T6A.
3.  Connect a 3½" Black wire from pin 6, T6A to pin 2, C201.
4.  Connect a 2½" Yellow wire from pin 1, T6A (S2) to pin 3, V1.
5.  Connect a 2½" Yellow/White wire from pin 4, T6A (S2) to pin 3, V101.
6.  Connect a 2½" Red/White wire from pin 2, T2B to pin 3, C201.
7.  Connect a 3½" White wire from pin 4, V1 (S1) to pin 5, V101 (S1).
8.  Connect a 6" White wire from pin 4, V101 (S1) to pin 5, V2 (S1).
9.  Connect a 5" White wire from pin 4, V2 (S1) to pin 5, V102 (S1).
10.  Connect a 5" <sup>Orange</sup> Yellow/White wire from pin 4, C201 to pin 8, V2 (S1).
11.  Connect a 7½" Yellow wire from pin 5, C201 to pin 3, V102 (S1).

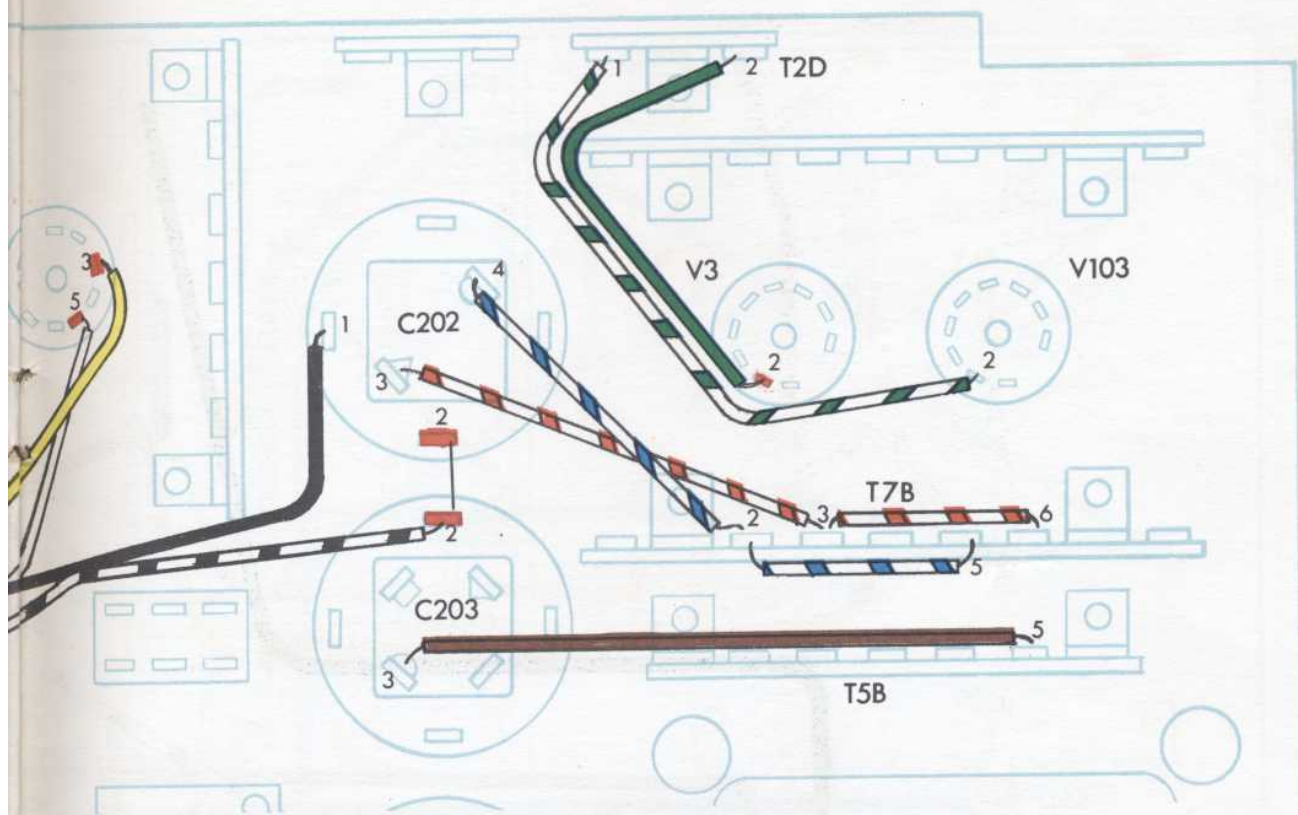

12.  Connect a 6" Black wire from pin 6, C201 to pin 4, T6C.
13.  Connect an 8½" Black wire from pin 6, C201 to pin 1, C202.
14.  Connect a 6" Red wire from pin 7, C201 to pin 5, T6C.
15.  Connect an 11" Black/White wire from pin 5, V1 (S1) to pin 2, C203.
16.  Connect a buss wire from pin 2, C203 (S2) to pin 2, C202 (S1).
17.  Connect a 4" Red/White wire from pin 3, C202 to pin 3, T7B.
18.  Connect a 2½" Red/White wire from pin 3, T7B to pin 6, T7B.
19.  Connect a 4" Blue/White wire from pin 4, C202 to pin 2, T7B.
20.  Connect a 2½" Blue/White wire from pin 2, T7B to pin 5, T7B.
21.  Connect a 5½" Green/White wire from pin 1, T2D to pin 2, V103 (S1).
22.  Connect a 4" Green wire from pin 2, T2D to pin 2, V3 (S1).
23.  Connect a 5" Brown wire from pin 3, C203 to pin 5, T5B.
24.  Connect a buss wire from pin 2, T6B to pin 1, V2.
25.  Connect a 2½" Green wire from pin 6, T6B to pin 6, V2.

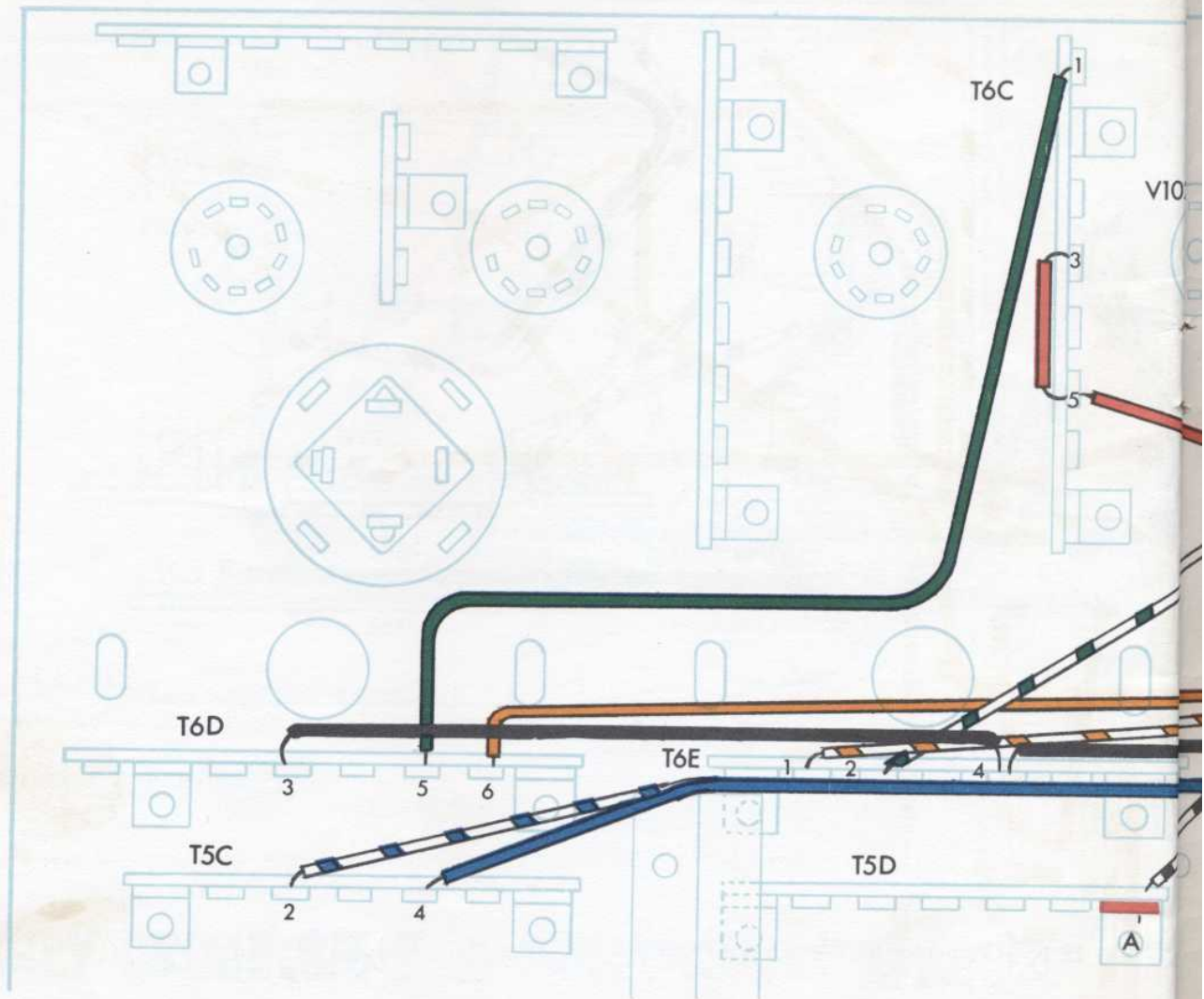

## ASSEMBLY GROUP BM-6

1.  Connect an 8½" Green wire from 5, T6D to pin 1, T6C.
2.  Connect an 8½" Green/White wire from pin 2, T6E to pin 1, T2C.
3.  Connect an 11" Orange wire from pin 6, T6D to pin 1, T7A.
4.  Connect a 12½" Orange/White wire from pin 1, T6E to pin 7, T7A.
5.  Connect a 2½" Red wire from pin 3, T6C to pin 5, T6C.
6.  Connect a 7½" Red wire from pin 5, T6C to pin 4, T7B.
7.  Connect a 5" White wire from pin 4, V102 (S1) to pin 4, C203.
8.  Connect a 4" Black wire from pin 1, C204 to pin 1, C202.
9.  Connect a 4½" Black wire from pin 1, C202 to pin 2, T7A.
10.  Connect a 2½" <sup>Orange</sup> ~~Black~~ wire from pin 2, T7A to pin 4, T7A.
11.  Connect a 2½" <sup>Green</sup> Black wire from pin 4, T7A to pin 6, T7A.
12.  Connect a 2½" Orange wire from pin 1, T7A to pin 7, V3 (S1).

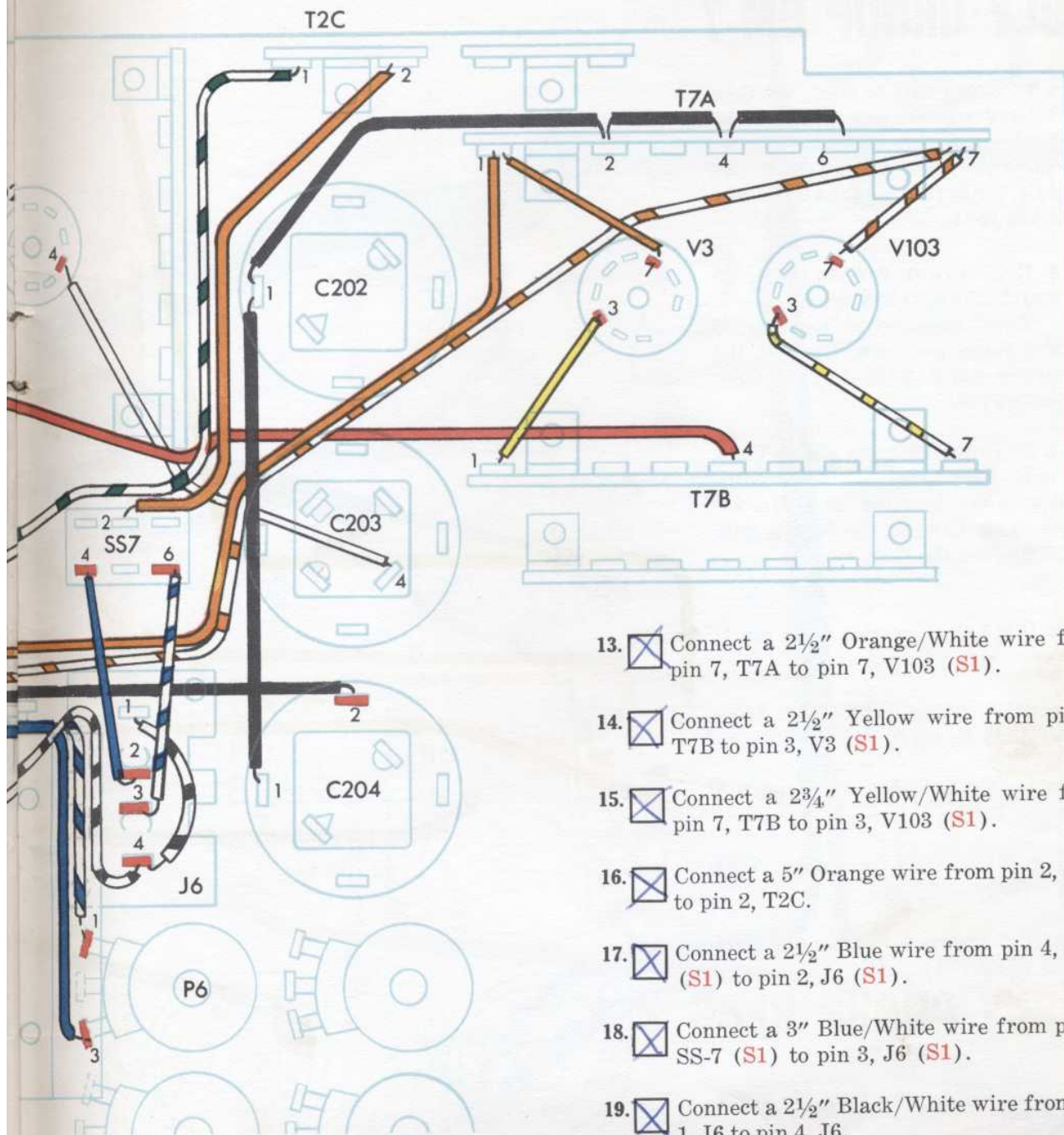

13.  Connect a 2½" Orange/White wire from pin 7, T7A to pin 7, V103 (S1).
14.  Connect a 2½" Yellow wire from pin 1, T7B to pin 3, V3 (S1).
15.  Connect a 2¾" Yellow/White wire from pin 7, T7B to pin 3, V103 (S1).
16.  Connect a 5" Orange wire from pin 2, SS-7 to pin 2, T2C.
17.  Connect a 2½" Blue wire from pin 4, SS-7 (S1) to pin 2, J6 (S1).
18.  Connect a 3" Blue/White wire from pin 6, SS-7 (S1) to pin 3, J6 (S1).
19.  Connect a 2½" Black/White wire from pin 1, J6 to pin 4, J6.
20.  Connect a 3" Black/White wire from pin 4, J6 (S2) to lug "A" T5D (S1).
21.  Connect a 5½" Black wire from pin 3, T6D to pin 4, T6E.
22.  Connect a 4¾" Black wire from pin 4, T6E to pin 2, C204 (S1).
23.  Connect an 8½" Blue/White wire from pin 2, T5C to pin 1, P6 (S1).
24.  Connect an 8½" Blue wire from pin 4, T5C to pin 3, P6 (S1).

# ASSEMBLY GROUP BM-7

1.  Connect a 3" Brown wire to pin 4, V3. Connect a 3" Grey wire to pin 5, V3. Twist these two wires together so that there are **at least 4 turns per inch**. Connect the Brown wire to pin 4, V103 (S1) and the Grey wire to pin 5, V103 (S1).
2.  Connect a 12½" Brown wire to pin 4, V3 (S2). Connect a 12½" Grey wire to pin 5, V3 (S2). Twist these wires together so there are **4 turns per inch**. Connect the Brown wire to pin 2, V105 and the Grey wire to pin 7, V105.
3.  Connect a 5" Brown wire to pin 2, V105. Connect a 5" Grey wire to pin 7, V105. Twist these wires together so there are **4 turns per inch**. Connect the Brown wire to pin 5, V201 and the Grey wire to pin 7, V201.
4.  Connect a 10½" Orange wire from pin 1, SS-7 (S1) to pin 5, V5.
5.  Connect a 6½" Orange/White wire from pin 3, SS-7 (S1) to pin 5, V105.
6.  Connect a 6½" Green/White wire from pin 2, T5D to pin 1, P5 (S1).
7.  Connect a 6" Green wire from pin 4, T5D to pin 3, P5 (S1).
8.  Connect a 2½" Yellow wire from pin 2, P6 (S1) to pin 2, P8 (S1).
9.  Connect a 2½" Yellow wire from pin 2, P5 (S1) to pin 2, P7 (S1).
10.  Connect a 2½" White wire from pin 1, P8 to pin 1, P7 (S1).
11.  Connect a 2½" White wire from pin 3, P8 (S1) to pin 3, P7.
12.  Connect an 8" White wire from pin 3, P7 (S2) to pin 4, T5B.
13.  Connect a 10" Blue wire from pin 4, C202 to pin 1, RWS-2 (S1).
14.  Connect a 6" Red wire from pin 2, T5E to pin 2, T5F.
15.  Connect an 8" Red wire from pin 2, T5F to pin 1, RWS-1.

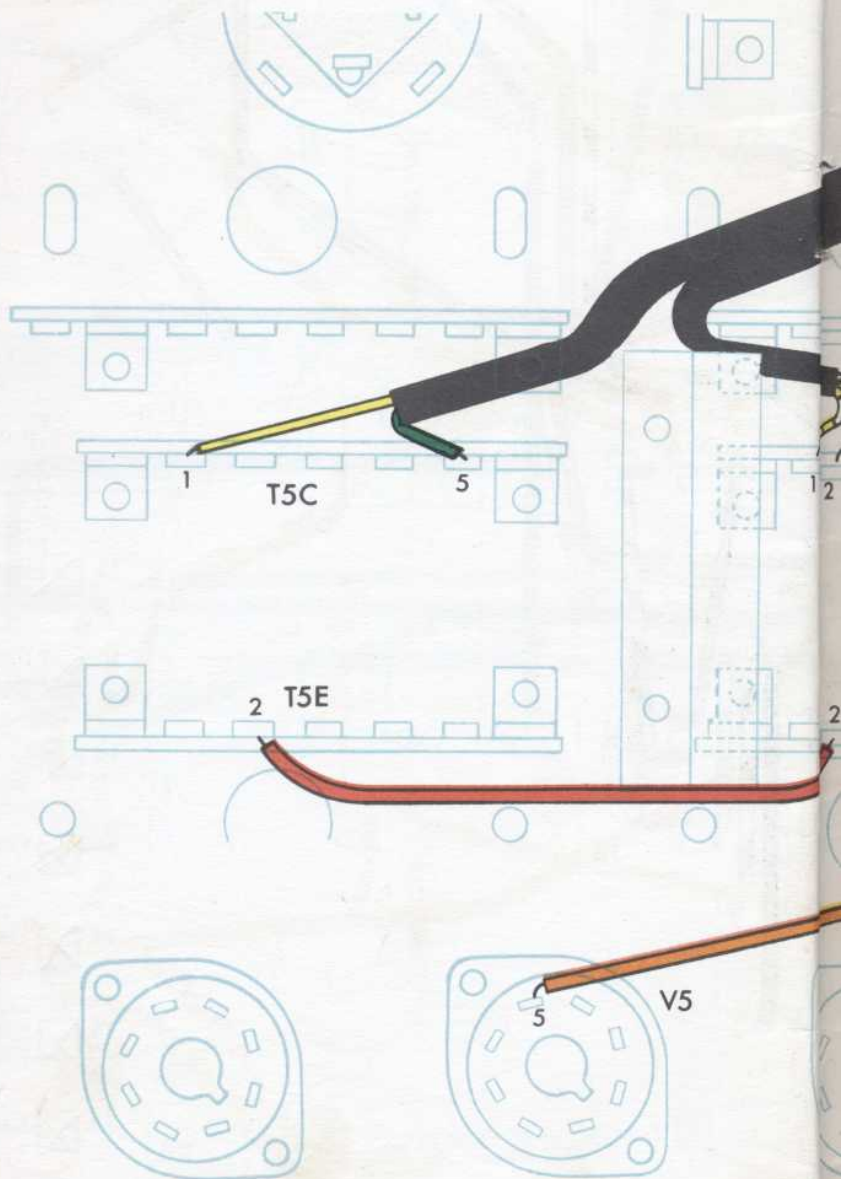

16.  Place a 10½" piece of Black Conductive Vinyl\* over a 13" Yellow/White wire and a 13½" Green/White wire. At one end, pull out about 1" of the bare wire that passes thru the tubing. At this end connect the Yellow/White wire to pin 1, V103, the Green/White wire to pin 8, V103, and the bare wire to lug "B" T7B (S1). At the other end connect the Yellow/White wire to pin 1, T5D and the Green/White wire to pin 5, T5D.

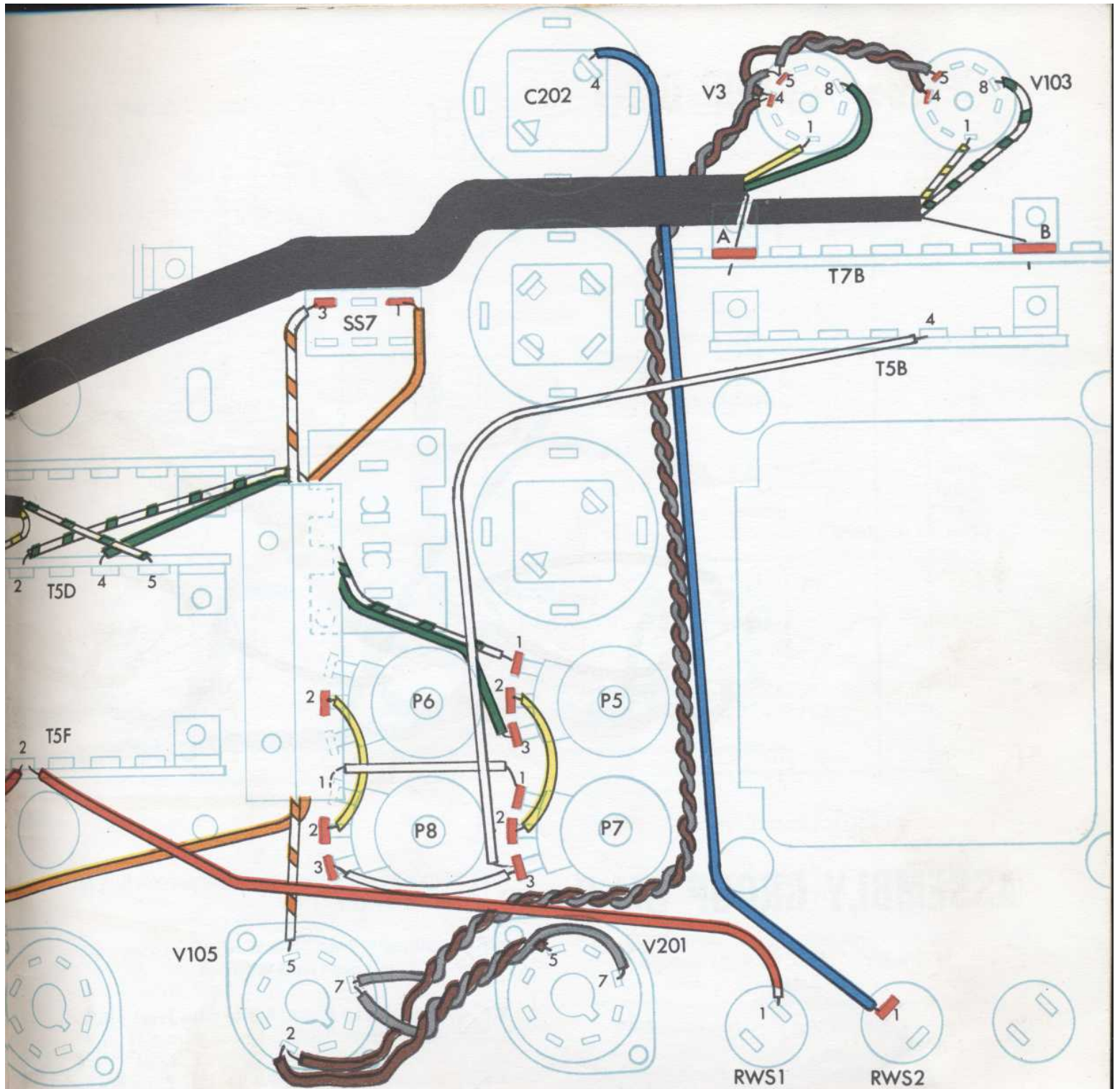

17.  Place a 9" piece of Black Conductive Vinyl over a 12" Yellow wire and an 11½" Green wire. At one end pull out about 1" of the bare wire. At this end connect the Yellow wire to pin 1, V3, the Green wire to pin 8, V3, and the bare wire to lug "A" T7B (S1). At the other end connect the Yellow wire to pin 1, T5C and the Green wire to pin 5, T5C.

\*See Page 8 for a description of this item.

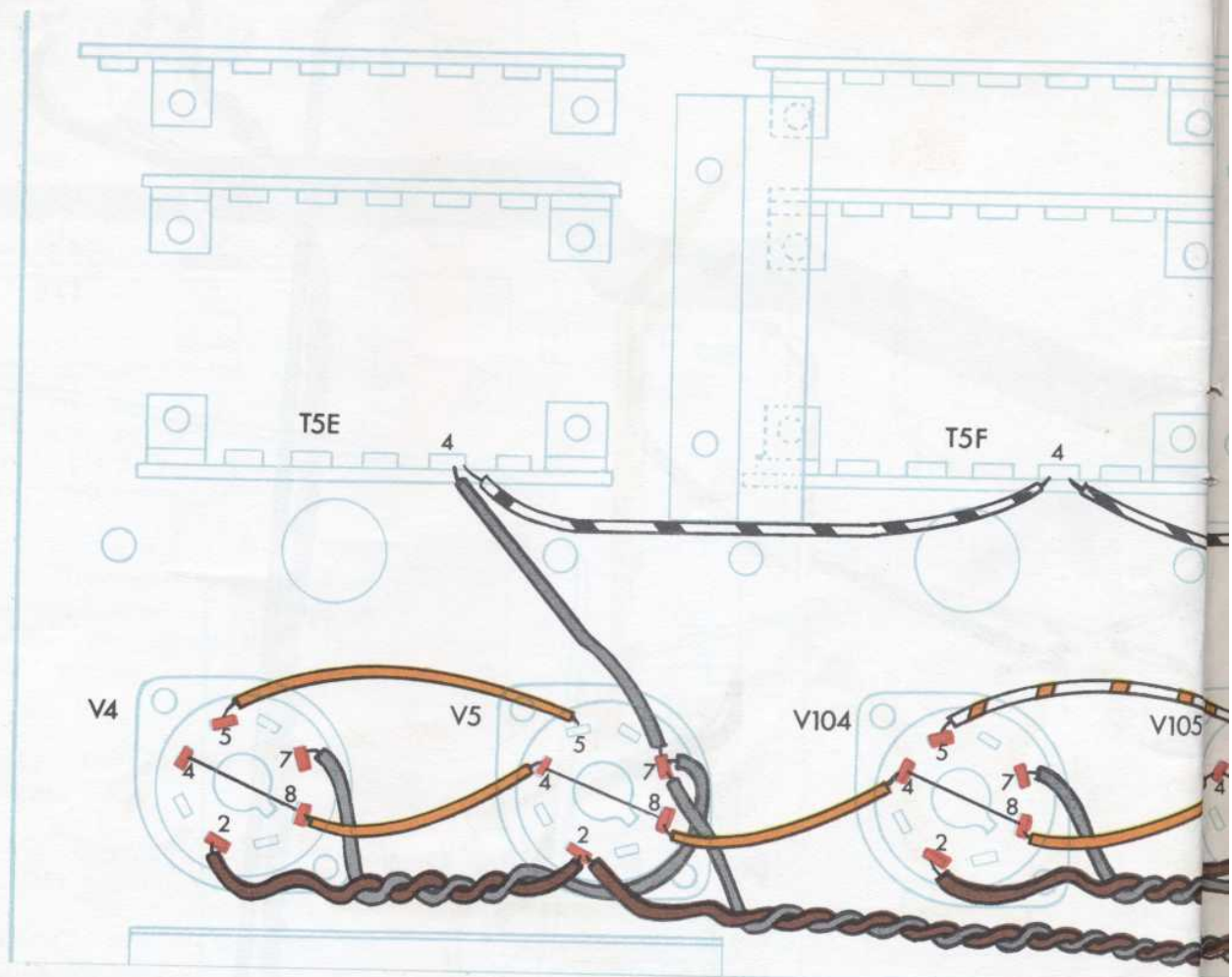

## ASSEMBLY GROUP BM-8

1.  Connect a 5" Red wire from pin 3, C204 to pin 1, RWS-1 (S2).
2.  Connect a 7½" Red/White wire from pin 4, C204 to pin 1, RWS-3 (S1).
3.  Connect a 5" Black/White wire from pin 4, T5E to pin 4, T5F.
4.  Connect a 6" Black/White wire from pin 4, T5F to pin 1, C204 (S2).
5.  Connect a 5" Brown wire to pin 2, V4 (S1).  
Connect a 5" Grey wire to pin 7, V4 (S1).  
Twist these two wires together (4 turns per inch). Connect the Brown wire to pin 2, V5 and the Grey wire to pin 7, V5.
6.  Connect a 9½" Brown wire to pin 2, V5 (S2).  
Connect a 9½" Grey wire to pin 7, V5.  
Twist these two wires together (4 turns per inch). Connect the Brown wire to pin 5, V201 and the Grey wire to pin 7, V201.

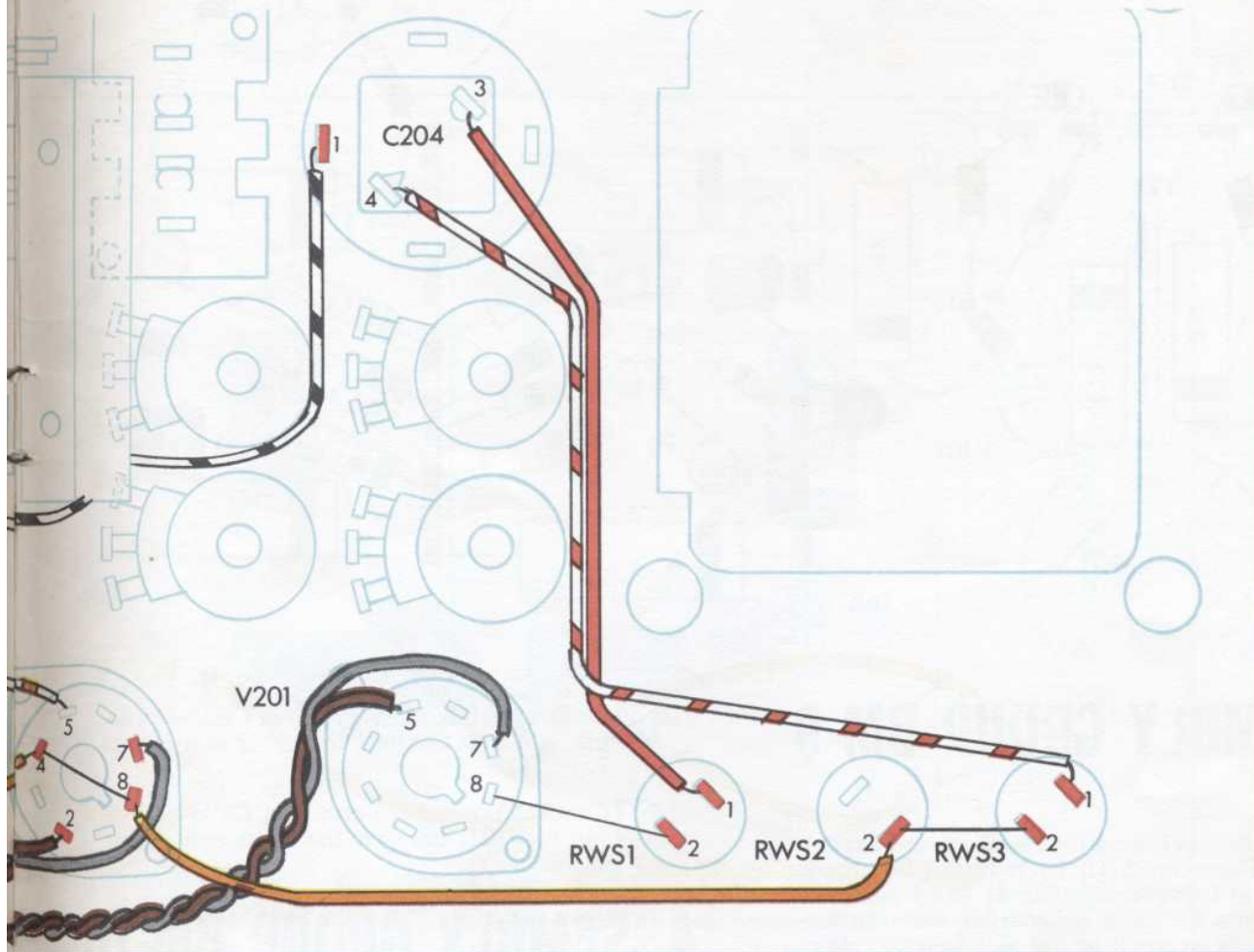

7.  Connect a 5" <sup>Orange</sup> ~~Brown~~ wire to pin 2, V104 (S1). Connect a 5" <sup>Green</sup> ~~Grey~~ wire to pin 7, V104 (S1). Twist these two wires together (4 turns per inch). Connect the Brown wire to pin 2, V105 (S3) and the Grey wire to pin 7, V105 (S3).
8.  Connect a buss wire from pin 4, V4 (S1) to pin 8, V4.
9.  Connect a buss wire from pin 4, V5 to pin 8, V5.
10.  Connect a buss wire from pin 4, V104 to pin 8, V104.
11.  Connect a buss wire from pin 4, V105 to pin 8, V105.
12.  Connect a <sup>Green</sup> buss wire from pin 8, V201 to pin 2, RWS-1 (S1).

13.  Connect a buss wire from pin 2, RWS-2 to pin 2, RWS-3 (S1).
14.  Connect a 5½" Orange wire from pin 8, V105 (S2) to pin 2, RWS-2 (S2).
15.  Connect a 2½" Orange wire from pin 8, V4 (S2) to pin 4, V5 (S2).
16.  Connect a 2½" Orange wire from pin 8, V5 (S2) to pin 4, V104 (S2).
17.  Connect a 2½" Orange wire from pin 8, V104 (S2) to pin 4, V105 (S2).
18.  Connect a 3½" Orange wire from pin 5, V4 (S1) to pin 5, V5.
19.  Connect a 3½" Orange/White wire from pin 5, V104 (S1) to pin 5, V105.
20.  Connect a 3½" Grey wire from pin 4, T5E to pin 7, V5 (S3).

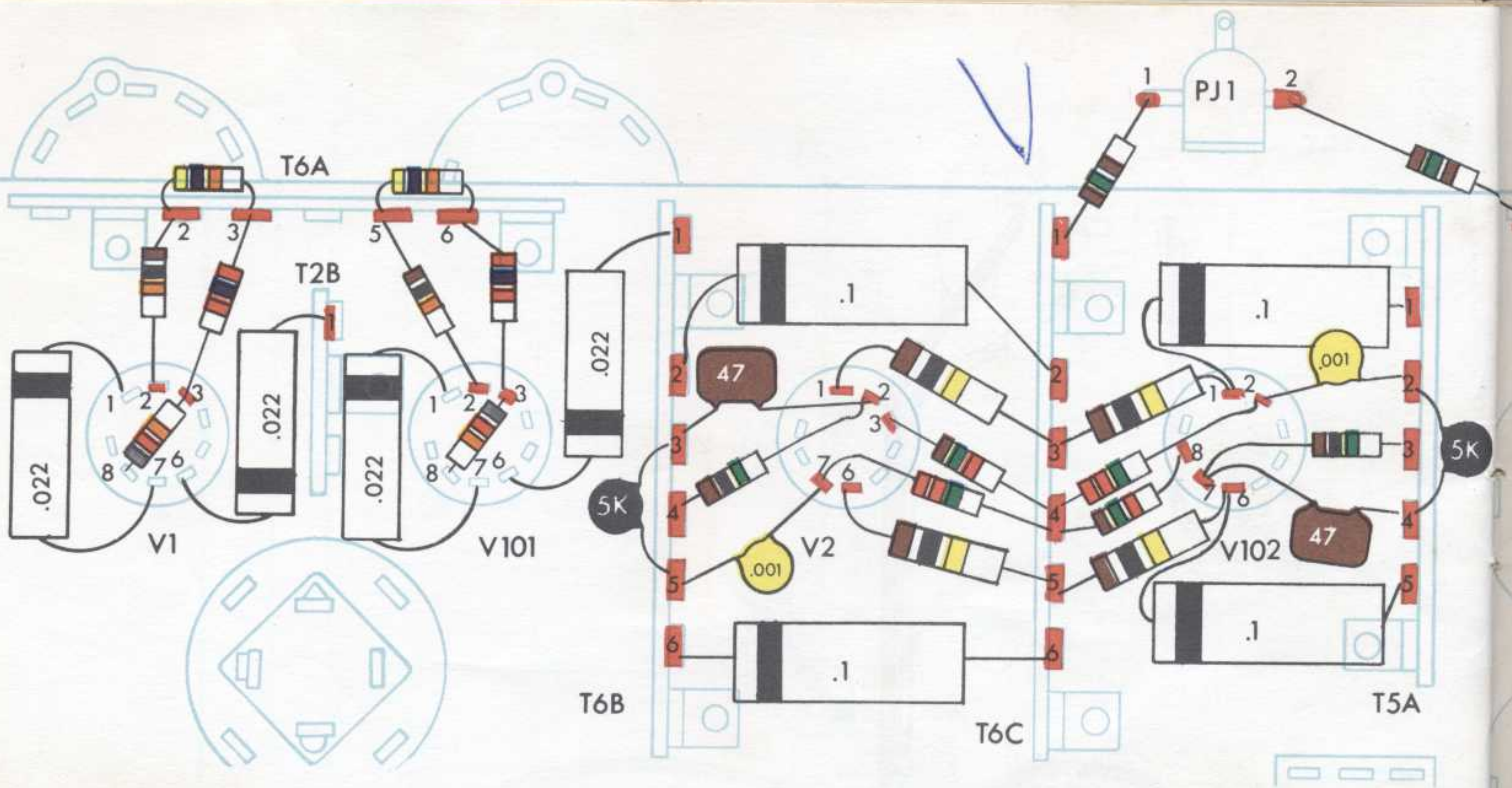

## ASSEMBLY GROUP BM-9

You will be working with resistors and capacitors now. These must all be trimmed to proper length before being connected. It is advisable to keep the leads as short as possible and the mechanical joints as small as possible to avoid short circuits with other wires, terminal pins, or the chassis itself. Whenever a wire is soldered, carefully inspect it to make sure it is not causing a short circuit.

1.  Connect a 47K resistor (Yellow, Purple, Orange) from pin 2, T6A to pin 3, T6A.
2.  Connect a 47K resistor (Yellow, Purple, Orange) from pin 5, T6A to pin 6, T6A.
3.  Connect a 10K resistor (Brown, Black, Orange) from pin 2, V1 (S1) to pin 2, T6A (S3).
4.  Connect a 10K resistor (Brown, Black, Orange) from pin 2, V101 (S1) to pin 5, T6A (S3).
5.  Connect an 82K resistor (Grey, Red, Orange) from pin 8, V1 to pin 3, V1.
6.  Connect an 82K resistor (Grey, Red, Orange) from pin 8, V101 to pin 3, V101.
7.  Connect a 2.7K resistor (Red, Purple, Red) from pin 3, V1 (S3) to pin 3, T6A (S5).
8.  Connect a 2.7K resistor (Red, Purple, Red) from pin 3, V101 (S3) to pin 6, T6A (S7).
9.  Connect the banded end of a CPM-.022 to pin 1, V1. Connect the other end to pin 7, V1.
10.  Connect the banded end of a CPM-.022 to pin 6, V1. Connect the other end to pin 1, T2B (S2).

11.  Connect the banded end of a CPM-.022 to pin 1, V101. Connect the other end to pin 7, V101.
12.  Connect the banded end of a CPM-.022 to pin 6, V101. Connect the other end to pin 1, T6B (S2).

## ASSEMBLY GROUP BM-10

1.  Connect the banded end of a CPM-.1 to pin 2, T6B (S2). Connect the other end to pin 2, T6C (S2).
2.  Connect the banded end of a CPM-.1 to pin 6, T6B (S2). Connect the other end to pin 6, T6C (S3).
3.  Connect the banded end of a CPM-.1 to pin 1, V102. Connect the other end to pin 1, T5A (S3).
4.  Connect the banded end of a CPM-.1 to pin 6, V102. Connect the other end to pin 5, T5A (S2).
5.  Connect a CC-5 NPO from pin 3, T6B to pin 5, T6B.
6.  Connect a CC-5 NPO from pin 2, T5A to pin 4, T5A.
7.  Connect a CM-47 from pin 3, T6B (S3) to pin 2, V2.
8.  Connect a CM-47 from pin 7, V102 to pin 4, T5A (S3).
9.  Connect a CC-.001 from pin 5, T6B (S3) to pin 7, V2.
10.  Connect a CC-.001 from pin 2, V102 to pin 2, T5A (S3).
11.  Connect a 1.5K resistor (Brown, Green, Red) from pin 3, V2 (S1) to pin 4, T6C.
12.  Connect a 1.5K resistor (Brown, Green, Red) from pin 4, T6C to pin 8, V102 (S1).

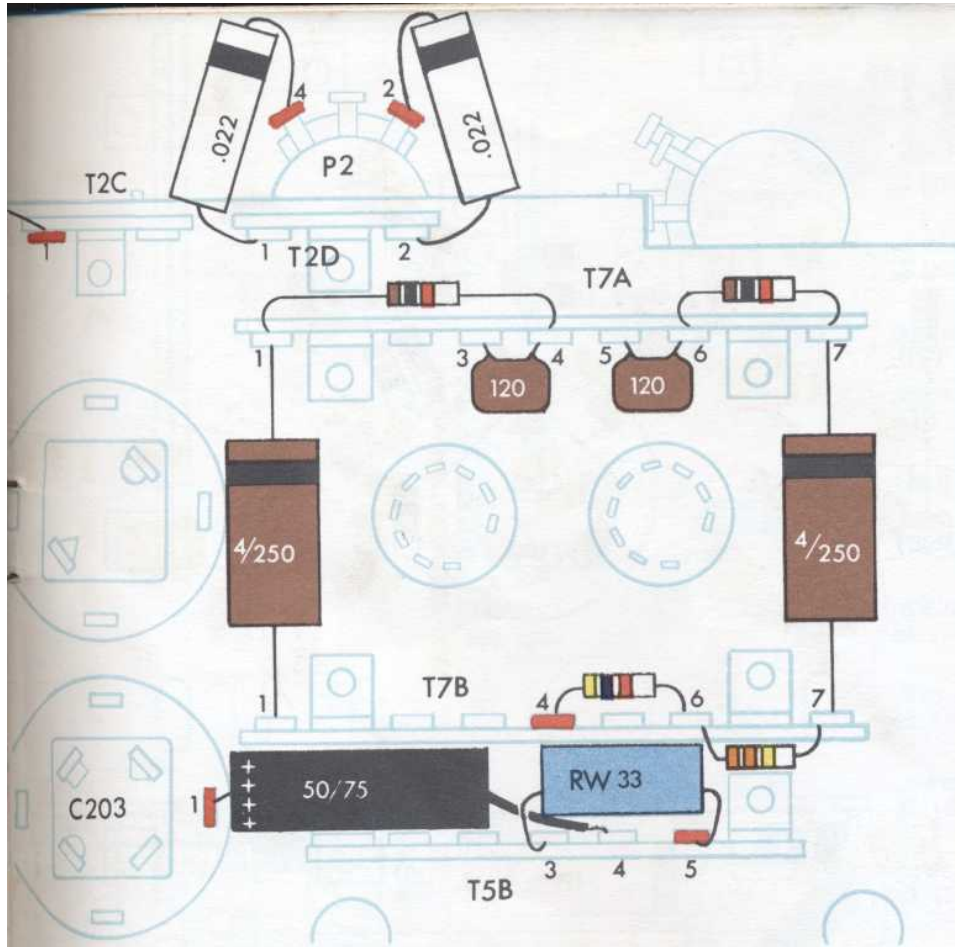

## ASSEMBLY GROUP BM-11

1.  Connect a 1M resistor (Brown, Black, Green) from pin 4, T6B (S2) to pin 2, V2 (S2).
2.  Connect a 1M resistor (Brown, Black, Green) from pin 7, V102 (S2) to pin 3, T5A (S2).
3.  Connect a large 100K resistor (Brown, Black, Yellow) from pin 1, V2 (S2) to pin 3, T6C.
4.  Connect a large 100K resistor (Brown, Black, Yellow) from pin 3, T6C (S4) to pin 1, V102 (S2).
5.  Connect a large 100K resistor (Brown, Black, Yellow) from pin 6, V2 (S2) to pin 5, T6C.
6.  Connect a large 100K resistor (Brown, Black, Yellow) from pin 5, T6C (S5) to pin 6, V102 (S2).
7.  Connect a 2.2M resistor (Red, Red, Green) from pin 7, V2 (S2) to pin 4, T6C.
8.  Connect a 2.2M resistor (Red, Red, Green) from pin 4, T6C (S6) to pin 2, V102 (S2).
9.  Connect a 150 ohm resistor (Brown, Green, Brown) from pin 1, PJ-1 (S1) to pin 1, T6C (S3).
10.  Connect a 150 ohm resistor (Brown, Green, Brown) from pin 2, PJ-1 (S1) to pin 1, T2C (S3).
11.  Connect the banded end of a CPM-.022 to pin 4, P2 (S2). Connect the other end to pin 1, T2D.

12.  Connect the banded end of a CPM-.022 to pin 2, P2 (S2). Connect the other end to pin 2, T2D.

## ASSEMBLY GROUP BM-12

1.  Connect a 1K resistor (Brown, Black, Red) from pin 1, T7A to pin 4, T7A.
2.  Connect a 1K resistor (Brown, Black, Red) from pin 6, T7A to pin 7, T7A.
3.  Connect a CM-120 from pin 3, T7A to pin 4, T7A.
4.  Connect a CM-120 from pin 5, T7A to pin 6, T7A.
5.  Connect a 4.7K resistor (Yellow, Purple, Red) from pin 4, T7B (S2) to pin 6, T7B.
6.  Connect a 330K resistor (Orange, Orange, Yellow) from pin 6, T7B to pin 7, T7B.
7.  Connect an RW-33 from pin 3, T5B to pin 5, T5B (S2).
8.  Connect the end having the plus (+) signs of a CET-50/75 to pin 1, C203 (S2). Add a 1/2" of spaghetti to the other end. Connect this end to pin 4, T5B.
9.  Connect the banded end of a CET-4/250 to pin 1, T7A. Connect the other end to pin 1, T7B.
10.  Connect the banded end of a CET-4/250 to pin 7, T7A. Connect the other end to pin 7, T7B.

## ASSEMBLY GROUP BM-13

1.  Connect a 1M resistor (Brown, Black, Green) from pin 1, T2D (S3) to pin 2, T7A.
2.  Connect a 1M resistor (Brown, Black, Green) from pin 2, T2D (S3) to pin 2, T7A (S5).
3.  Connect a 330K resistor (Orange, Orange, Yellow) from pin 1, T7A (S5) to pin 1, T7B.
4.  Connect a 330K resistor (Orange, Orange, Yellow) from pin 7, T7A (S5) to pin 7, T7B (S4).
5.  Connect an 8.2K resistor (Grey, Red, Red) from pin 3, T7A (S2) to pin 6, V3.
6.  Connect an 8.2K resistor (Grey, Red, Red) from pin 5, T7A (S2) to pin 6, V103.
7.  Connect a large 15K resistor (Brown, Green, Orange) from pin 4, T7A (S5) to pin 8, V3 (S2).
8.  Connect a large 15K resistor (Brown, Green, Orange) from pin 6, T7A (S4) to pin 8, V103 (S2).
9.  Connect a large 15K resistor (Brown, Green, Orange) from pin 2, T7B (S3) to pin 1, V3 (S2).
10.  Connect a large 15K resistor (Brown, Green, Orange) from pin 5, T7B (S2) to pin 1, V103 (S2).
11.  Connect one end of a 150K resistor (Brown, Green, Yellow) to pin 3, T7B. Pass the other end thru pin 9, V3 (S2)\* and connect it to pin 6, V3 (S2).
12.  Connect one end of a 150K resistor (Brown, Green, Yellow) to pin 6, T7B (S4). Pass the other end thru pin 9, V103 (S2)\* and connect it to pin 6, V103 (S2).

\*A wire passing through a pin counts as two connections to that pin when it is soldered.

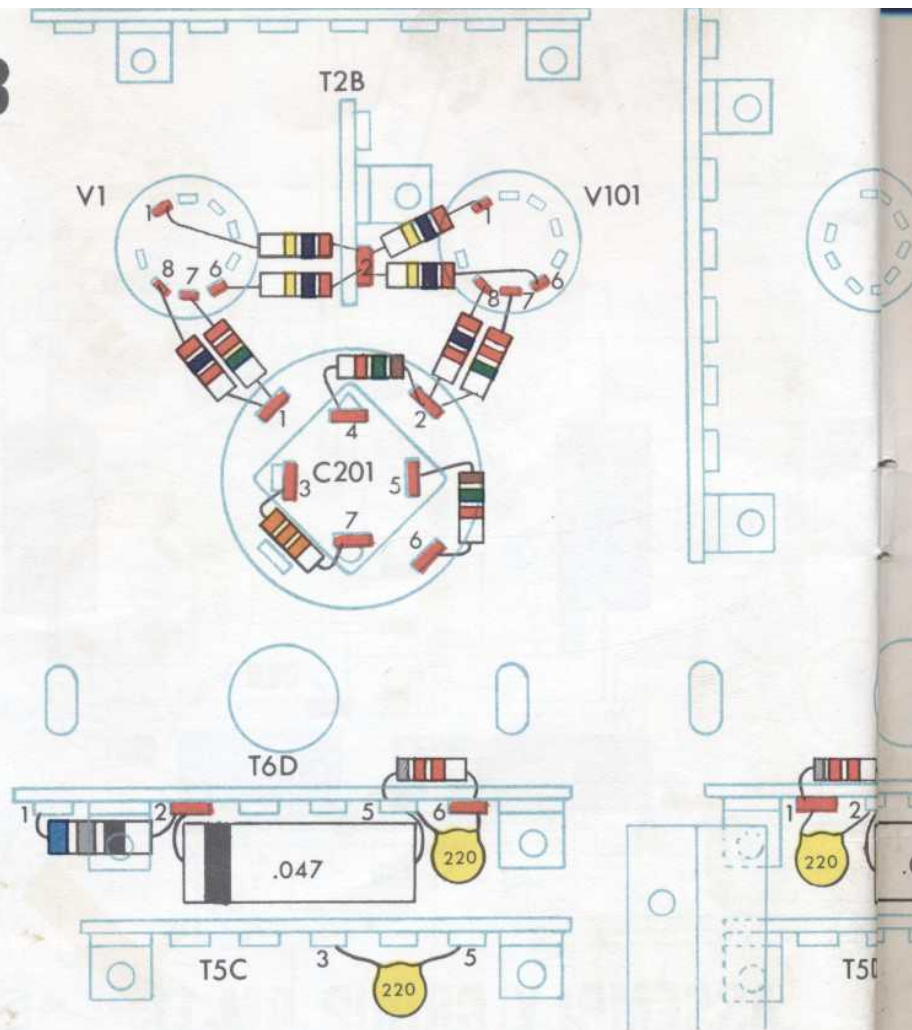

## ASSEMBLY GROUP BM-14

1.  Connect a CC-.02 from pin 2, T2C to pin 5, C202 (S1).
2.  Connect a 3.3M resistor (Orange, Orange, Green) from pin 2, T2C to pin 3, C202.
3.  Connect a 2.7K resistor (Red, Purple, Red) from pin 2, T2C (S4) to pin 1, C202 (S4).
4.  Connect a large 4.7K resistor (Yellow, Purple, Red) from pin 3, C202 (S3) to pin 4, C202 (S3).
5.  Connect a large 18 ohm resistor (Brown, Grey, Black) from pin 3, C203 (S2) to pin 5, C203.
6.  Connect a large 18 ohm resistor (Brown, Grey, Black) from pin 5, C203 (S2) to pin 6, C203.
7.  Connect a large 18 ohm resistor (Brown, Grey, Black) from pin 6, C203 (S2) to pin 4, C203 (S2).
8.  Connect a CC-.001 from pin 2, SS-7 (S2) to pin 5, SS-7.
9.  Connect a 470K resistor (Yellow, Purple, Yellow) from pin 5, SS-7 (S2) to pin 1, J6 (S2).
10.  Connect a 3W-270 ohm resistor from pin 3, C204 (S2) to pin 4, C204 (S2).
11.  Connect a 330K resistor (Orange, Orange, Yellow) from pin 1, T7B (S4) to pin 3, T7B (S4).
12.  Connect a 22K resistor (Red, Red, Orange) from pin 3, T5B (S3) to pin 4, T5B (S3).

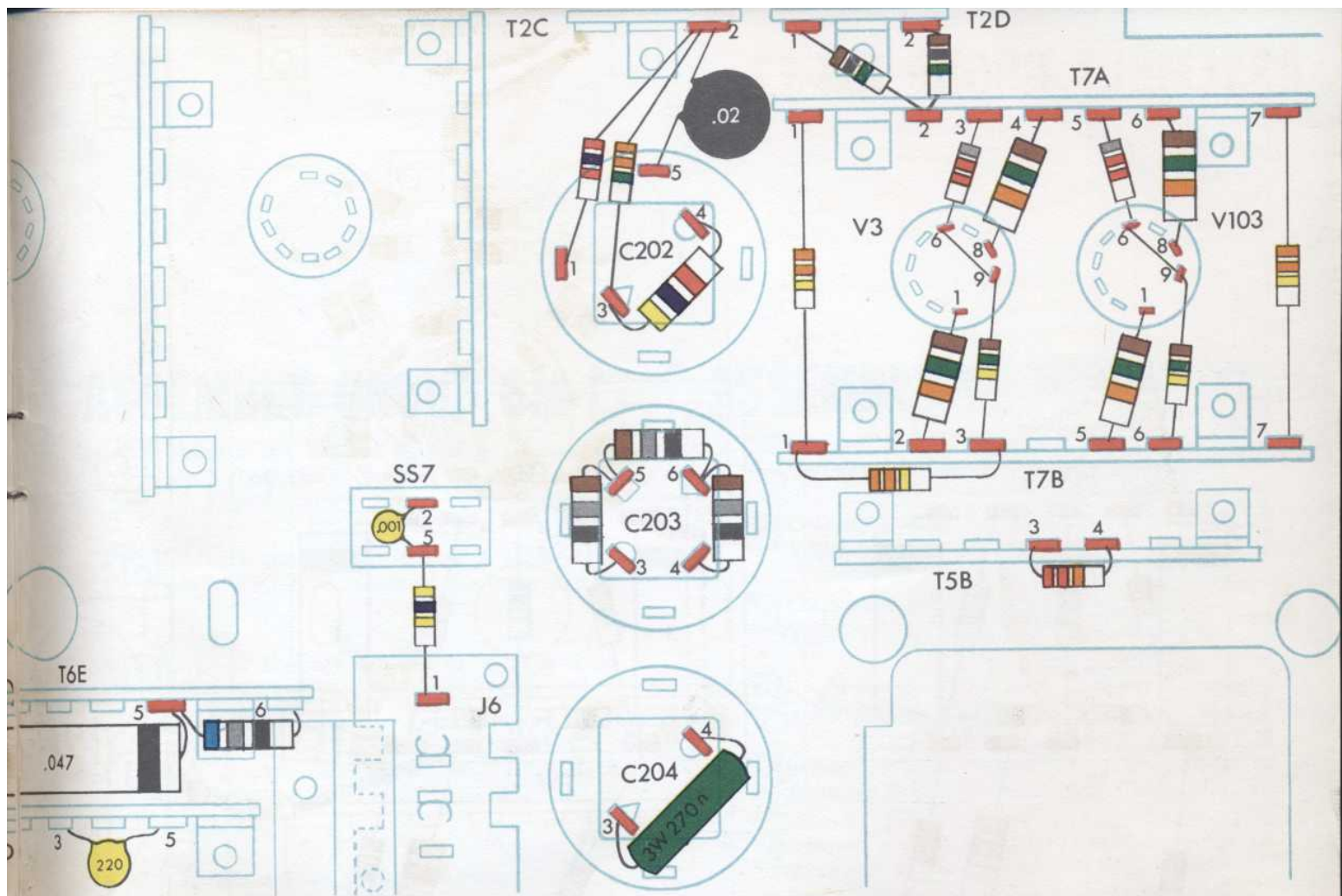

## ASSEMBLY GROUP BM-15

1.  Connect a 270K resistor (Red, Purple, Yellow) from pin 1, V1 (S2) to pin 2, T2B.
2.  Connect a 270K resistor (Red, Purple, Yellow) from pin 6, V1 (S2) to pin 2, T2B.
3.  Connect a 270K resistor (Red, Purple, Yellow) from pin 1, V101 (S2) to pin 2, T2B.
4.  Connect a 270K resistor (Red, Purple, Yellow) from pin 6, V101 (S2) to pin 2, T2B (S5).
5.  Connect a 2.7K resistor (Red, Purple, Red) from pin 8, V1 (S2) to pin 1, C201.
6.  Connect a 2.7K resistor (Red, Purple, Red) from pin 8, V101 (S2) to pin 2, C201.
7.  Connect a 2.2M resistor (Red, Red, Green) from pin 7, V101 (S3) to pin 2, C201.
8.  Connect a 2.2M resistor (Red, Red, Green) from pin 7, V1 (S3) to pin 1, C201 (S3).
9.  Connect a 1.5K resistor (Brown, Green, Red) from pin 4, C201 (S2) to pin 2, C201 (S4).
10.  Connect a 1.5K resistor (Brown, Green, Red) from pin 5, C201 (S2) to pin 6, C201 (S3).
11.  Connect a 33K resistor (Orange, Orange, Orange) from pin 3, C201 (S2) to pin 7, C201 (S2).

## ASSEMBLY GROUP BM-16

1.  Connect a large 68 ohm resistor, (Blue, Grey, Black) from pin 1, T6D to pin 2, T6D.
2.  Connect a large 68 ohm resistor (Blue, Grey, Black) from pin 5, T6E to pin 6, T6E.
3.  Connect the banded end of a CPM-.047 to pin 2, T6D (S2). Connect the other end to pin 5, T6D.
4.  Connect the banded end of a CPM-.047 to pin 5, T6E (S2), connect the other end to pin 2, T6E.
5.  Connect a CC-220 from pin 5, T6D to pin 6, T6D.
6.  Connect a CC-220 from pin 1, T6E to pin 2, T6E.
7.  Connect an 8.2K resistor (Grey, Red, Red) from pin 1, T6E (S3) to pin 2, T6E.
8.  Connect an 8.2K resistor (Grey, Red, Red) from pin 5, T6D to pin 6, T6D (S3).
9.  Connect a CC-220 from pin 3, T5C to pin 5, T5C.
10.  Connect a CC-220 from pin 3, T5D to pin 5, T5D.

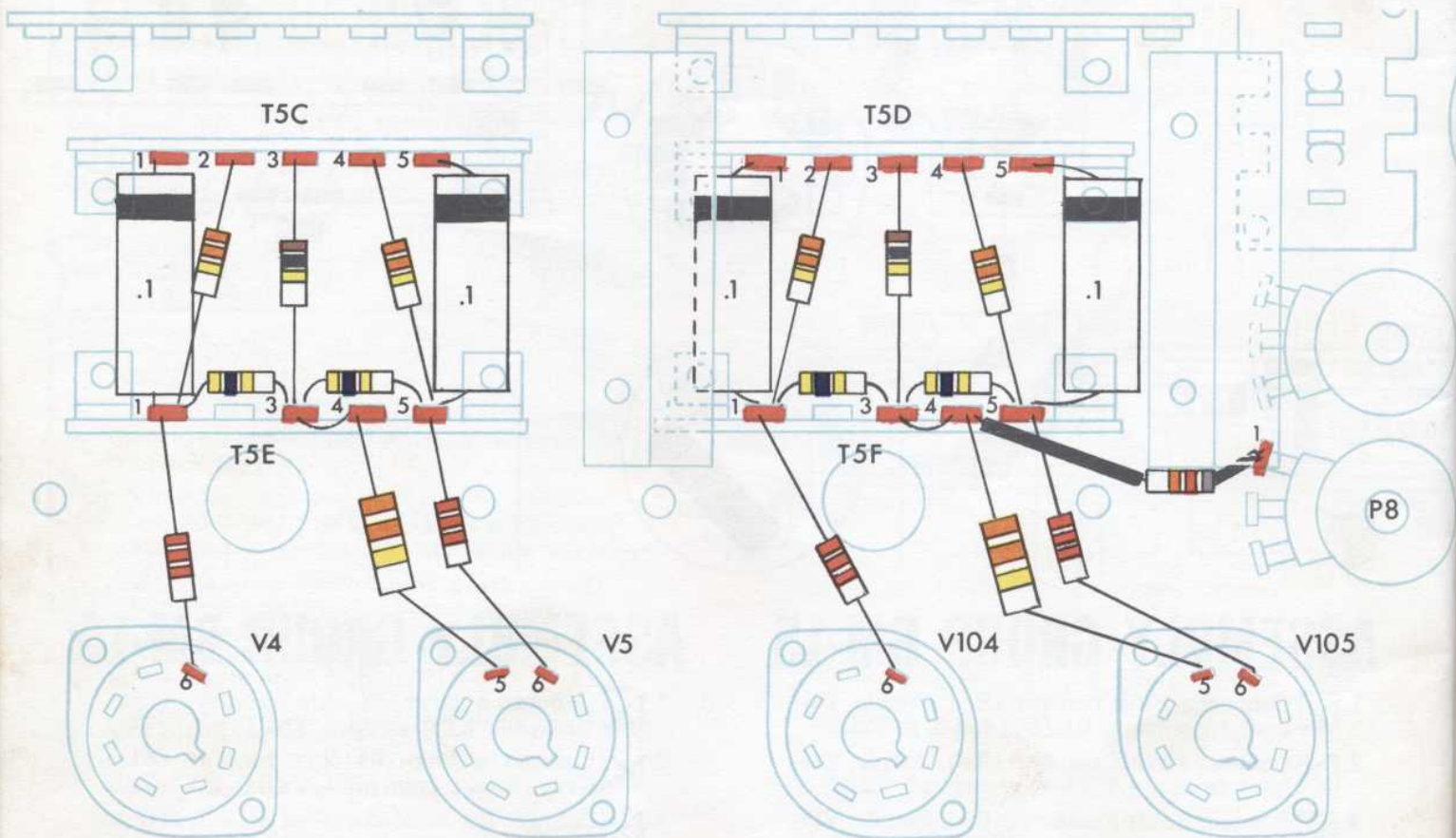

## ASSEMBLY GROUP BM-17

1.  Connect the banded end of a CPM-.1 to pin 1, T5C (S2). Connect the other end to pin 1, T5E.
2.  Connect the banded end of a CPM-.1 to pin 5, T5C (S3). Connect the other end to pin 5, T5E.
3.  Connect the banded end of a CPM-.1 to pin 1, T5D (S2). Connect the other end to pin 1, T5F.
4.  Connect the banded end of a CPM-.1 to pin 5, T5D (S3). Connect the other end to pin 5, T5F.
5.  Connect a 330K resistor (Orange, Orange, Yellow) from pin 2 T5C (S2) to pin 1, T5E.
6.  Connect a 330K resistor (Orange, Orange, Yellow) from pin 4, T5C (S2) to pin 5, T5E.
7.  Connect a 330K resistor (Orange, Orange, Yellow) from pin 2, T5D (S2) to pin 1, T5F.
8.  Connect a 330K resistor (Orange, Orange, Yellow) from pin 4, T5D (S2) to pin 5, T5F.
9.  Connect one end of a 100K resistor (Brown, Black, Yellow) to pin 3, T5C (S2). Pass the other end thru pin 3, T5E and connect it to pin 4, T5E.
10.  Connect one end of a 100K resistor (Brown, Black, Yellow) to pin 3, T5D (S2). Pass the other end thru pin 3, T5F and connect it to pin 4, T5F.

## ASSEMBLY GROUP BM-18

1.  Connect a 470K resistor (Yellow, Purple, Yellow) from pin 1, T5E to pin 3, T5E.
2.  Connect a 470K resistor (Yellow, Purple, Yellow) from pin 3, T5E (S4) to pin 5, T5E.
3.  Connect a 470K resistor (Yellow, Purple, Yellow) from pin 1, T5F to pin 3, T5F.
4.  Connect a 470K resistor (Yellow, Purple, Yellow) from pin 3, T5F (S4) to pin 5, T5F.
5.  Connect a 2.2K resistor (Red, Red, Red) from pin 6, V4 (S1) to pin 1, T5E (S4).
6.  Connect a 2.2K resistor (Red, Red, Red) from pin 6, V5 (S1) to pin 5, T5E (S4).  
**Do not block transformer mounting hole.**
7.  Connect a 2.2K resistor (Red, Red, Red) from pin 6, V104 (S1) to pin 1, T5F (S4).
8.  Connect a 2.2K resistor (Red, Red, Red) from pin 6, V105 (S1) to pin 5, T5F (S4).  
**Do not block transformer mounting hole.**
9.  Connect a large 3.3 ohm resistor (Orange, Orange, Gold) from pin 5, V5 (S3) to pin 4, T5E (S4).
10.  Connect a large 3.3 ohm resistor (Orange, Orange, Gold) from pin 5, V105 (S3) to pin 4, T5F.
11.  Add a 1/4" piece of spaghetti to one end of an 82K resistor (Grey, Red, Orange). Connect this end to pin 1, P8 (S2). Add a 3/4" piece of spaghetti to the other end. Connect this end to pin 4, T5F (S5).

$\frac{3}{8}$ " SHEET METAL SCREWS (8)

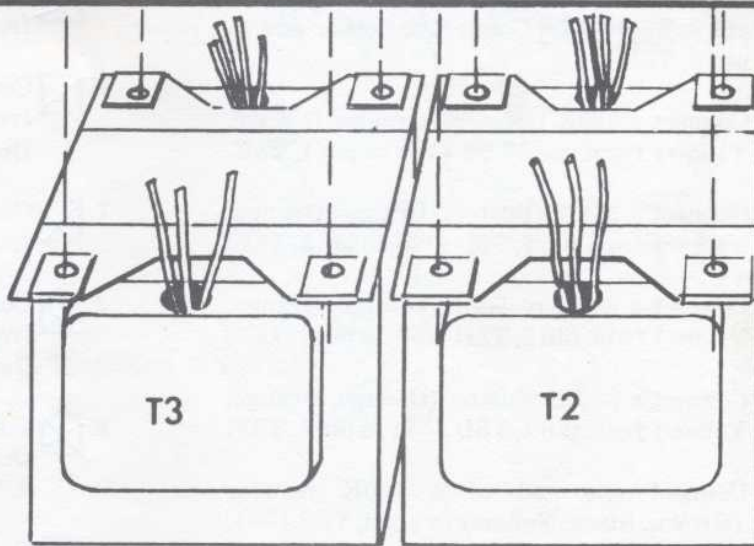
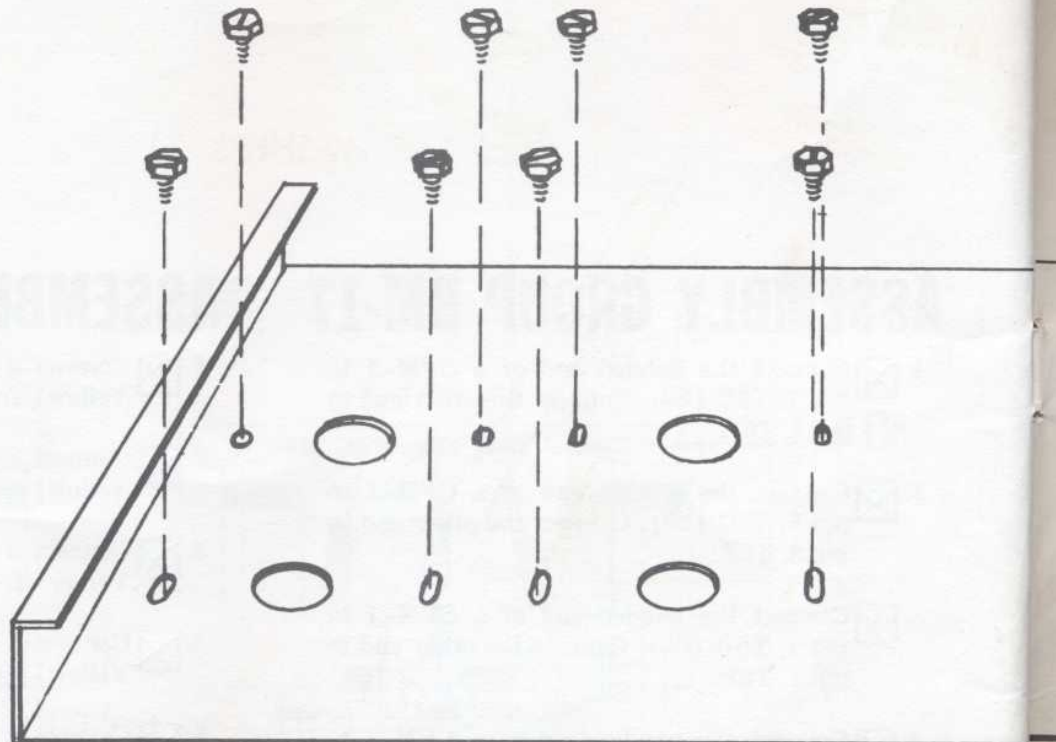

OUTPUT TRANSFORMERS

Dress leads from each end of the transformers thru the  $\frac{5}{8}$ " clearance holes

## MECHANICAL ASSEMBLY GROUP A-3

1.  Turn the chassis right side up. Take one of the output transformers (TRA-11-2) that you put to one side earlier, and, using the factory assembled clips as a guide, assemble a spring clip fastener to the two feet that do not already have a clip on them. This transformer will be referred to as T2.

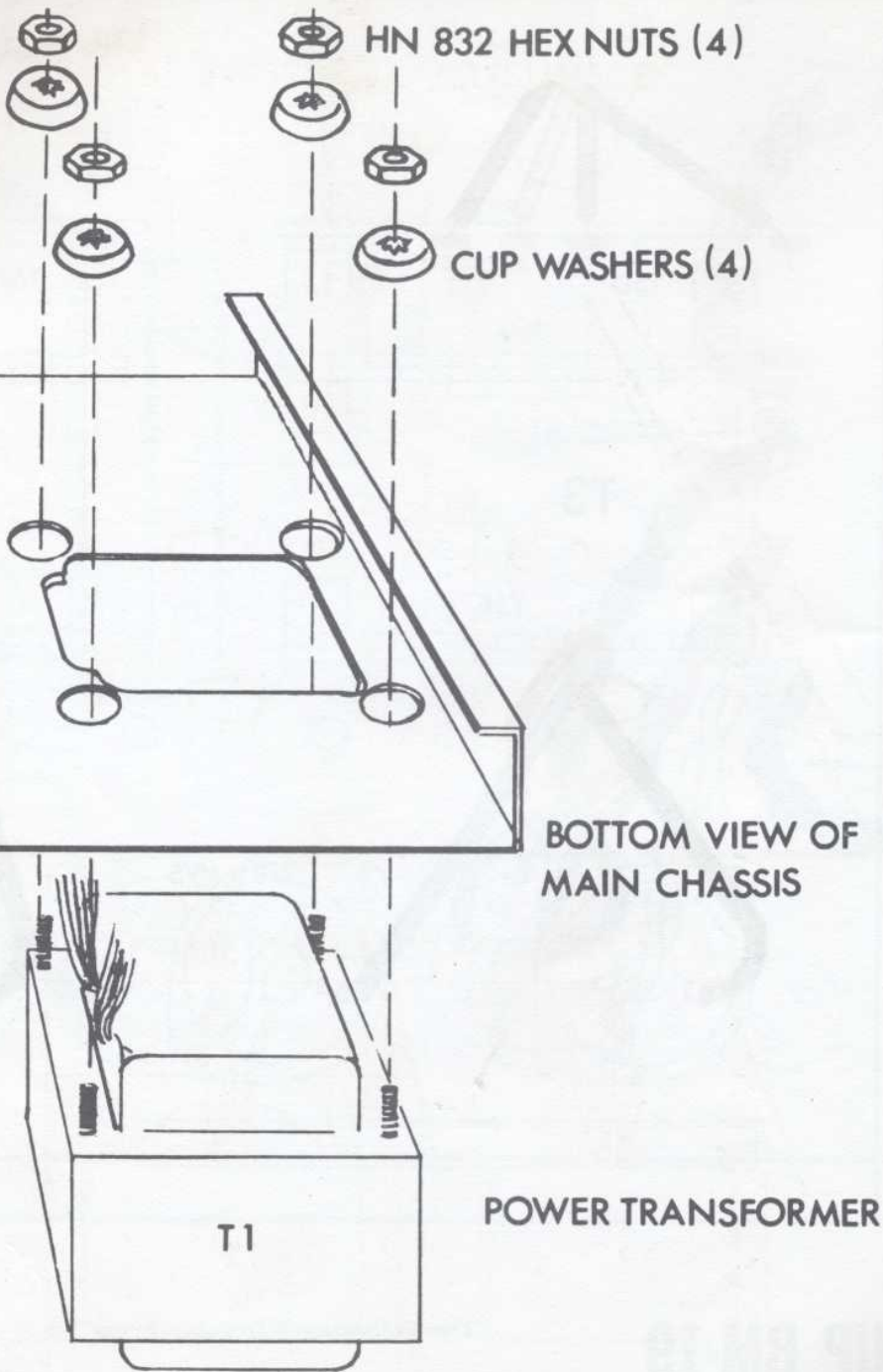

**FIGURE 9**

2.  Position T2 on the chassis as shown in (Figure 9). Be sure that the Red, Blue and Brown wires pass thru the hole nearest the rear. Hold the transformer in place and slowly turn the chassis over. Pull up on all the wires to remove the slack. Fasten T2 to the chassis with four  $\frac{3}{8}$ " sheet metal screws. (See Figure 9).
3.  Turn the chassis over and mount the second output transformer using the above procedure. This transformer will be called T3.
4.  Mount the power transformer (TR-13-3-2) as shown in (Figure 9) with four cup washers and four #832 nuts. This transformer will be called T1.

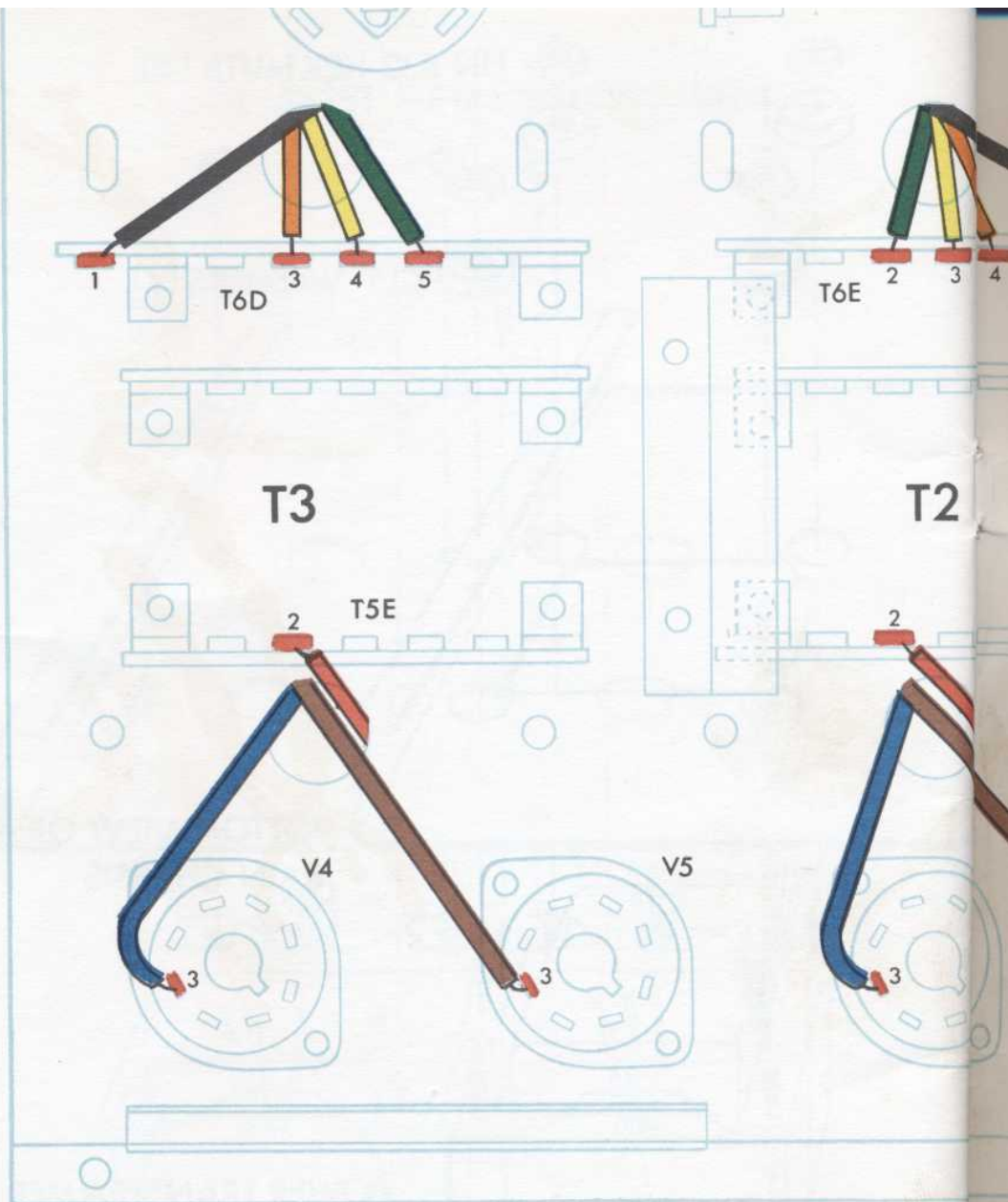

## ASSEMBLY GROUP BM-19

### The Following Wires Are From T2

1.  Connect the Blue wire to pin 3, V104 (S1).
2.  Connect the Brown wire to pin 3, V105 (S1).
3.  Connect the Red wire to pin 2, T5F (S3).
4.  Connect the Green wire to pin 2, T6E (S6).
5.  Connect the Yellow wire to pin 3, T6E (S2).
6.  Connect the Orange wire to pin 4, T6E (S4).
7.  Connect the Black wire to pin 6, T6E (S3).

### The Following Wires Are From T3

8.  Connect the Blue wire to pin 3, V4 (S1).
9.  Connect the Brown wire to pin 3, V5 (S1).
10.  Connect the Red wire to pin 2, T5E (S2).
11.  Connect the Green wire to pin 5, T6D (S6).
12.  Connect the Yellow wire to pin 4, T6D (S2).
13.  Connect the Orange wire to pin 3, T6D (S3).
14.  Connect the Black wire to pin 1, T6D (S4).

Because soldering of pin 1, T6D may burn the cover of the ESS cable beside it, take your pliers and rotate the ESS 90°.

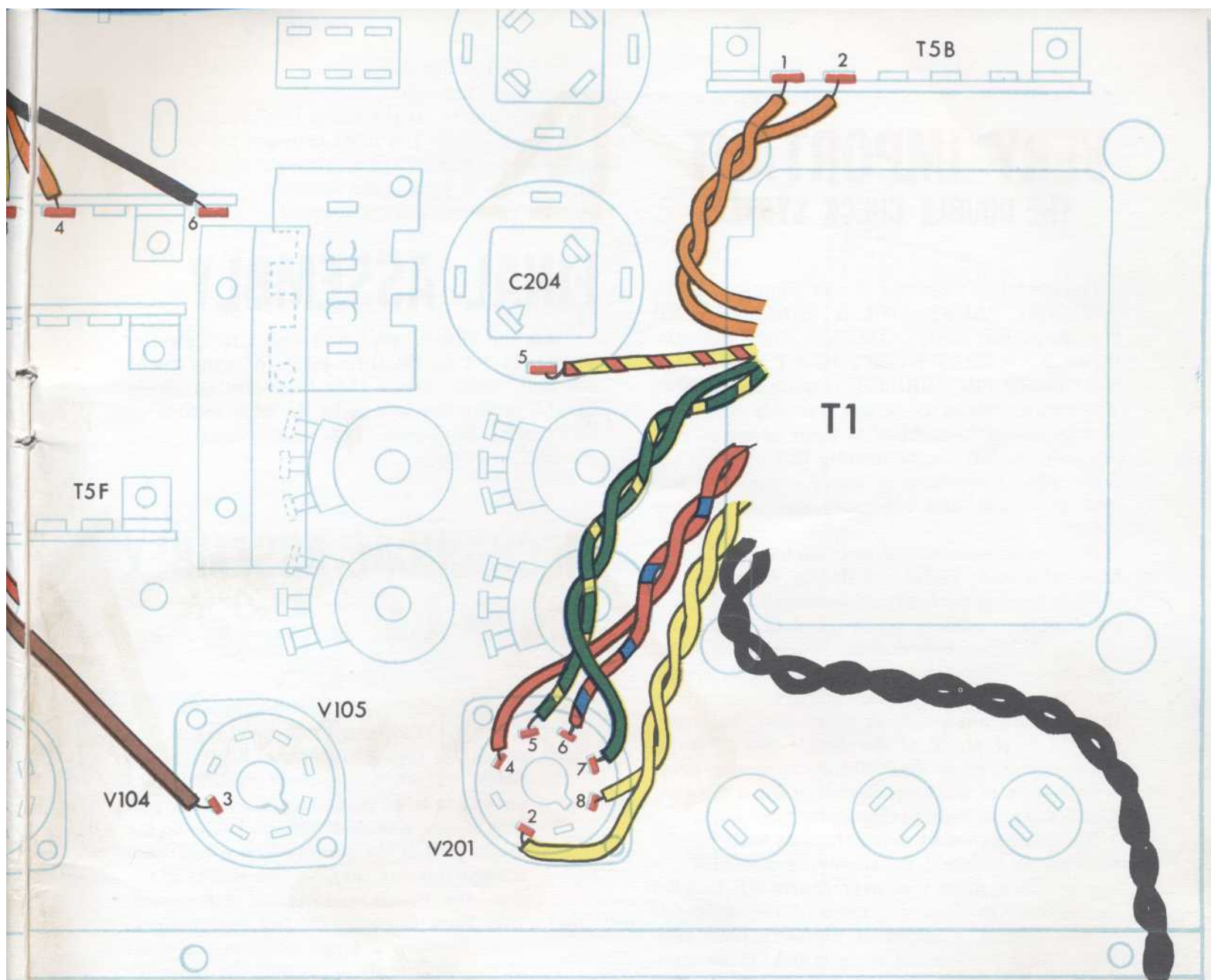

**The Following Wires Are From T1**

15.  Connect the Red/Yellow wire to pin 5, C204 (S1).
16.  Twist the two Orange wires together. Connect one to pin 1, T5B (S2). Connect the other one to pin 2, T5B (S2).
17.  Twist the Green and Green/Yellow wires together. Connect the Green wire to pin 7, V201 (S3). Connect the Green/Yellow wire to pin 5, V201 (S3).
18.  Twist the two Black wires together. Connect one to pin 2 on the Fuse Post (S2). Connect the other one to pin 1, AC-2 (S3). **Make sure that none of the wires or the solder touch the chassis.**

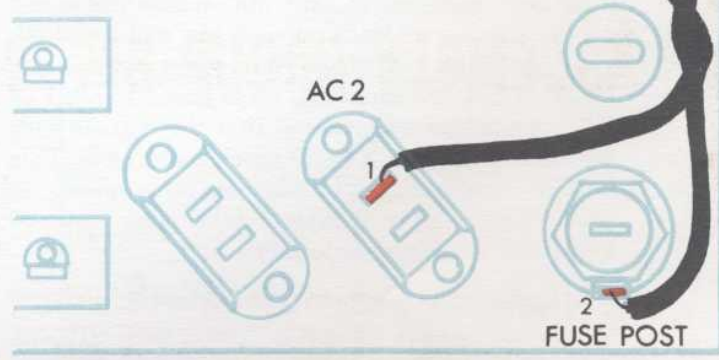

19.  Twist the two Yellow wires together. Connect one to pin 2, V201 (S1) and the other to pin 8, V201 (S2).
20.  Twist the Red and Red/Blue wires together. Connect the Red wire to pin 4, V201 (S1). Connect the Red/Blue wire to pin 6, V201 (S1).

# VERY IMPORTANT

## THE DOUBLE CHECK SYSTEM

The electrical assembly is now complete. IT IS TIME TO PAUSE FOR A MOMENT AND MAKE SURE THAT THERE ARE NO ERRORS, AND THAT EVERY JOINT HAS BEEN SOLDERED PROPERLY. It is quite understandable that at this stage of the assembly there will be a tremendous incentive to forge ahead quickly to finish the job. Unfortunately this attitude can cause you to overlook a small error that will lead to serious and expensive damage to your amplifier.

In extensive evaluation tests we had LK-72 kits built by a wide variety of people. Over 90% of the kits worked perfectly upon completion. Of this percentage, virtually everyone had taken the trouble to follow this double checking procedure, and most of them reported catching small errors. In those units that did not work we discovered that malfunction could, in every case, be traced directly to skipping of the double-check. Simple miswiring errors or short circuits prevented proper operation of the amplifier. Stop for a moment, RELAX, and be sure to check over your work.

An easy method of doing this has been provided. Call in a friend or another member of the family. Have them look over charts AF-1, AR-1 and AM-1. On these diagrams of the underside of the chassis, a series of numbers have been placed next to each pin or terminal. These numbers indicate the number of wires and leads (including those from resistors or capacitors) that have been soldered to that pin. While you count off the number of leads on each pin and terminal, your assistant can check your count against the chart. When you count the leads going to pin 1 of V3, your helper will observe that this agrees with his chart and place a small check mark on it. This will be continued until the entire amplifier is checked over. It will seldom take more than 20 minutes for this complete check.

WHILE YOU ARE COUNTING THE WIRES, YOU CAN ALSO BE CHECKING FOR SHORT CIRCUITS AND PROPER SOLDERING. It would be very handy if you had a tool with a small sharp point (like an ice pick) to probe the connections and make certain they are soldered properly. A pencil with a sharp point can also be used. Even the most meticulous worker can make a mistake or have a poorly soldered joint. LOOK SHARP! Move every lead and wire a little bit to insure it

is not accidentally causing a short circuit with some other wire or pin.

If a mistake is caught and it involves a component which is now too short to reach the correct pin, refer to (Figure 3) on splicing a piece of buss wire. This will work quite well and eliminate the need for purchasing a replacement.

## FINAL ASSEMBLY

Turn the chassis over and shake it violently. This is to get all the little pieces of wire out of the unit. Make certain that there are no pieces caught in any crevices or in the tube sockets or condenser can bases. This could cause short circuits.

## MECHANICAL ASSEMBLY GROUP A-4

- Assemble the front panel as shown in (Figure 10). Tighten a brass hex nut on the six shafts to hold the panel in place. The shafts on which the four medium sized knobs are to be assembled have a flat surface on one side. Position the knobs on the shafts so that the set screws are tightened against this flat surface. The shafts of the Bass and Treble controls are both concentric. Turn these shafts *full counterclockwise*. Position a large knob on the shaft of the Bass controls so that the indicator line on the knob is in the most counterclockwise position. Tighten the set screw making sure that this shaft stays full counterclockwise, assemble a small knob in the same manner as above. Repeat this procedure for assembling a large and small knob to the shaft of the Treble control.
- Mount the tubes using the lettering on the chassis as a guide. Locate the Loudness control on the front panel. Make sure that it is in the OFF position (full counterclockwise). Turn the unit on its side so you can readily see both the underside and top side of the chassis. Insert the line cord into an A.C. outlet (**Do not use with D.C.**) and turn the loudness control until it clicks on. Watch both the underside and top side for any signs of overheating, sparks, smoke, or unusually bright glowing tubes. At the first sign of trouble, turn the unit off and refer to the

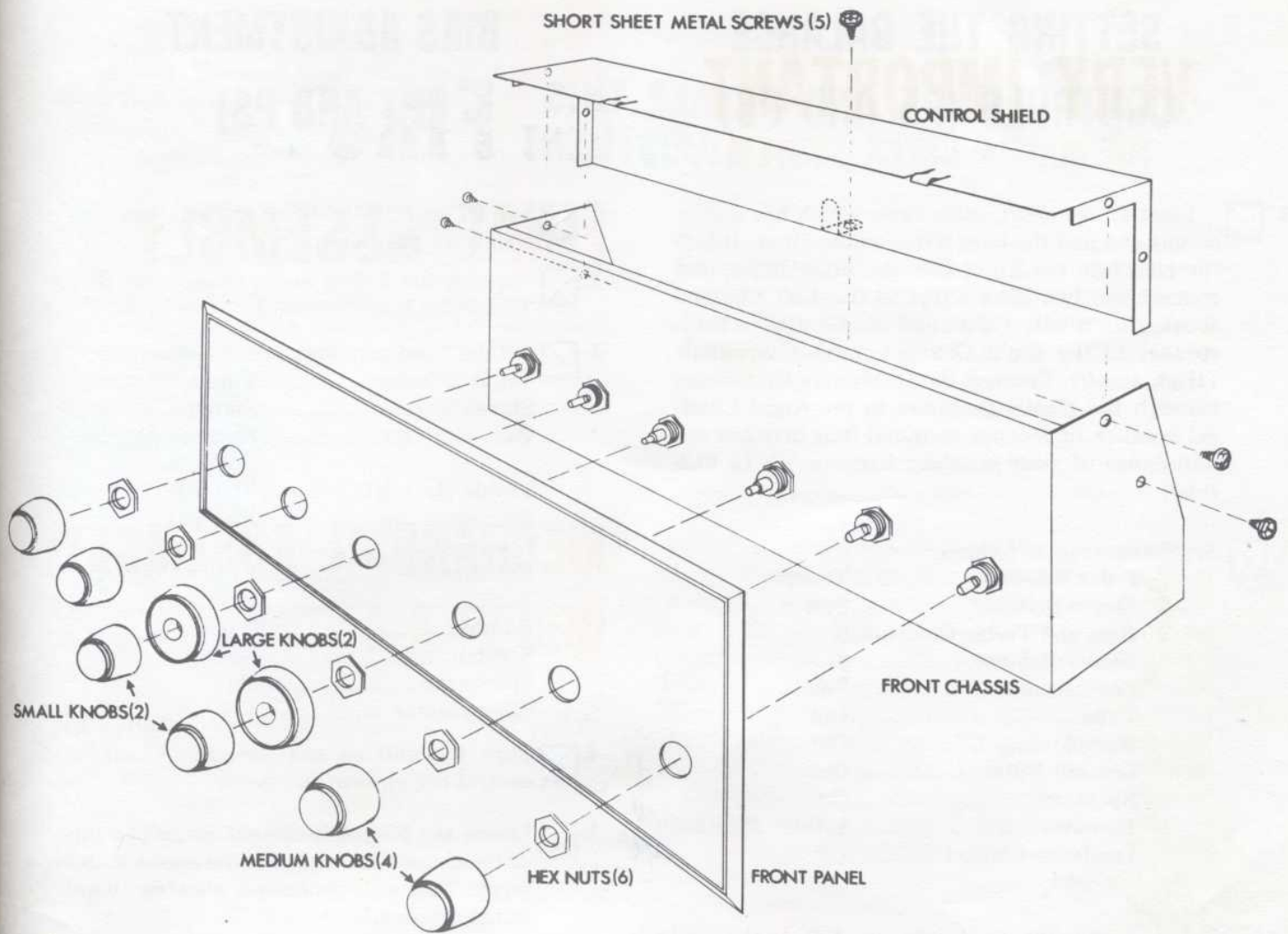

FIGURE 10

section entitled "In Case Of Difficulty" on page 57. If all seems right, turn the unit off, remove the line cord from the outlet, and continue.

3.  Place a tube shield over tubes V1, V101, V2, and V102. Press down hard with a counterclockwise motion to assemble the shields.
4.  Assemble the control shield with five of the short  $\frac{1}{4}$ " sheet metal screws. (See Figure 10.)
5.  Assemble the bottom cover as shown in (Figure 11).

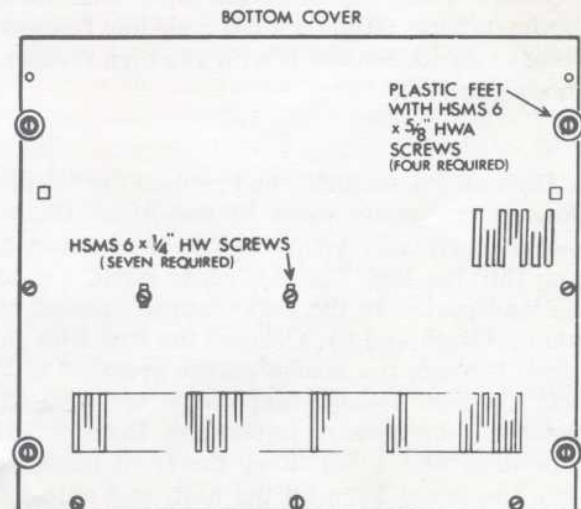

FIGURE 11

## SETTING THE BALANCE

### CONTROLS (P5 AND P6) TAKE THIS ADJUSTMENT

## BIAS ADJUSTMENT

### FOR P7 AND P8

1.  Identify the short audio cable which has a plug on one end and the bare wires on the other. Insert the plug into the Right Channel tuner input, and connect the two bare wires to the Left Channel speaker terminals (High and 0). Connect a loudspeaker to the Right Channel speaker terminals (High and 0). Connect the Greenwire that comes through the plastic grommet to the Right Channel speaker impedance terminal that matches the impedance of your speaker. Remove V3 (a 6U8 tube).

2.  Set the controls as follows:

Input Selector.....	Tuner
Stereo Selector .....	Stereo
Bass and Treble Controls..	0
Stereo Balance.....	0
Compensator.....	Loud
Tape.....	Out
Rumble.....	Out
Scratch Filter.....	Out
Speakers.....	On
Equalization.....	Either Position
Loudness Control.....	Off

3.  Insert the line cord into an A.C. outlet and turn the unit on. Wait a few minutes for the amplifier to completely warm up. Slowly turn the Loudness Control clockwise until you can just hear a low hum in the loudspeaker. (If you turn the volume up too high, the amplifier will oscillate and produce a motorboating noise). Take the small screwdriver and adjust P6 (on top of chassis) for minimum hum. (Hum is a 120 cycle low frequency noise — do not confuse it with any high frequency noises present).

4.  Turn off the amplifier and replace the V3 tube. Connect the audio cable to the Right Channel speaker terminals (High and 0) and insert the plug into the Left Channel tuner input. Connect the loudspeaker to the Left Channel speaker terminals (High and 0). Connect the Red wire that comes through the second plastic grommet to the Left Channel speaker impedance terminal that matches your speaker impedance. Remove V103 (the other 6U8 tube). Keep the front panel controls the same. Turn on the unit, and adjust P5 for minimum hum. Turn off the amplifier and replace V103 and remove the audio cable.

1.  Set P7 and P8 to their extreme *counter-clockwise* positions.

2.  Connect the 3 foot audio cable from Bias Test Point L to Channel L Tuner input.

3.  Set the front panel controls as follows:

Input Selector.....	Tuner
Stereo Selector.....	Stereo
Bass (L + R) .....	Extreme counter-clockwise
Treble (L + R).....	Flat (0)
Balance.....	Flat (0)
Loudness.....	Off
Equalization.....	Either Position
Tape.....	Out
Rumble.....	Out
Scratch.....	Out
Speakers.....	On
Compensator.....	Vol.

4.  Turn the unit on and turn the Loudness control full clockwise.

5.  Locate the Bias Adjustment Switch on top of the chassis and slide the button back and forth. This will produce a *clicking* sound in the speaker.

6.  Continue to slide the button back and forth causing the click to continue. At the same time, using the small screwdriver, turn P8 clockwise slowly. The click will become very faint and then begin to increase. Re-adjust P8 to the point where the click is the faintest.

7.  Remove the audio cable from Test Point L and insert the plug into Test Point R.

8.  Repeat the procedure outlined in steps 5 and 6, BUT ADJUST P7.

9.  Because P7 and P8 interact somewhat, you should repeat steps 6, 7 and 8 alternately until the faintest amount of clicking is heard.

### CONGRATULATIONS!

Now . . . sign your personal label "This kit was built by —" . . . connect your amplifier into the rest of your system (see instruction manual) . . . relax . . . with one of the finest amplifiers ever made.

