

**INSTRUCTION BOOK**  
**H·H·SCOTT**

LEADER IN AUDIO ENGINEERING AND DESIGN

**Model LK-48**

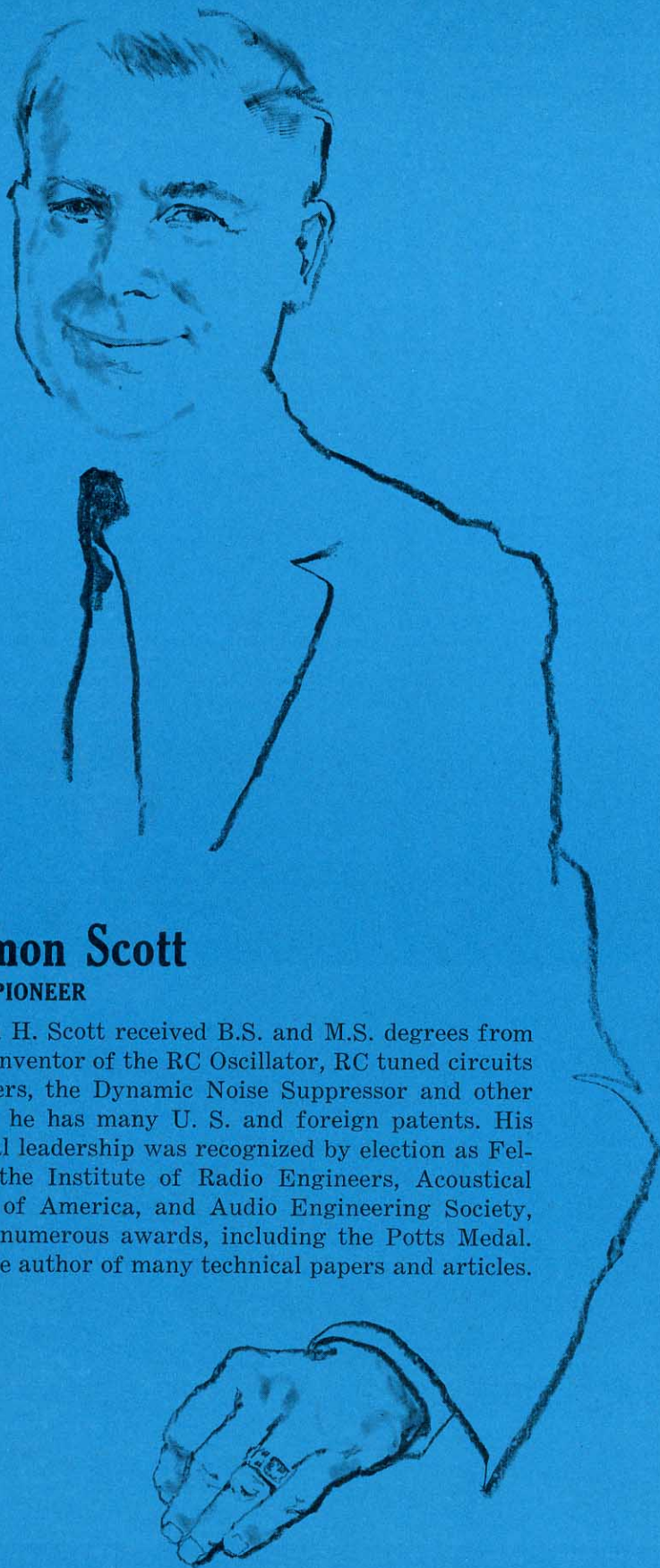

## Hermon Scott

### AUDIO PIONEER

Hermon H. Scott received B.S. and M.S. degrees from M.I.T. Inventor of the RC Oscillator, RC tuned circuits and filters, the Dynamic Noise Suppressor and other devices, he has many U. S. and foreign patents. His technical leadership was recognized by election as Fellow in the Institute of Radio Engineers, Acoustical Society of America, and Audio Engineering Society, and by numerous awards, including the Potts Medal. He is the author of many technical papers and articles.

## Important Firsts . . .

BY H. H. SCOTT

First high fidelity AM-FM Stereo tuner using wide range AM design. First to successfully use wide-band circuitry in high-fidelity FM tuners. First to market The Stereo-Daptor, a stereo control unit that prevents obsolescence. First to provide center channel output on Stereo amplifiers for added realism in playback.

# Introduction

The first true high fidelity complete amplifier appeared in 1947, H. H. Scott's Model 210A. This remarkable instrument introduced a score of unusual design features, which today are accepted and used by all manufacturers. The engineering innovations introduced in the 210A are typical of H. H. Scott, a company which has continued to pioneer in designing and producing new and better audio instruments. The exceptional design and careful manufacture that went into the 210A have been proven over the years . . . most of them are *still* in service, after more than 14 years. They work perfectly and compare favorably to products available today.

H. H. Scott's philosophy is not only to develop new and better instruments, but also to produce equipment that will last. There is no built-in obsolescence in H. H. Scott products. These brief notes try to indicate how this is accomplished by using the latest example of the H. H. Scott engineering laboratories, the LK-48.

## What is the function of a Power Amplifier and a Preamplifier Control Center

The purpose of a high fidelity power amplifier is to take weak signals, increase their strength tremendously, and convert them into watts of power necessary to move the cone of a speaker. It must do this without adding, subtracting, or altering the contents of the original signal in any way. Such alteration of the original program is referred to as "distortion."

The purpose of the preamplifier control center is twofold. First, it takes the exceptionally small output from the conventional magnetic phono pickup (3 to 16 millivolts in most cases) and steps it up to a level where it can be properly accepted by the power amplifier. The outputs of FM tuners, complete tape recorders, and crystal pickups are sufficiently strong so they do not need this preliminary preamplification and can be fed directly into the power amplifier.

The second function of the preamplifier control center is to permit the user to vary the sound to suit his taste. It permits him to increase or decrease the treble, bass, and volume. It permits him to select a wide range of program sources, reduce record scratch, and adjust record or tape equalization.

Your LK-48 offers on one compact chassis, four

pieces of precision equipment. There is a preamplifier control center and power amplifier for the left channel (Channel A), and a preamplifier control center and power amplifier for the right channel (Channel B). It is actually a remarkable accomplishment in engineering design, to have such outstanding laboratory performance on so simple and compact a unit.

## How does the Complete Amplifier Work

### PREAMPLIFIER STAGE

The very weak signals coming from the magnetic cartridge or tape head are fed into Mag High or Mag Low Inputs. They go to the first duo-triode 12AX7 tubes (V1 for the left or A channel, V2 for the right or B channel), where preamplification occurs.

Any noise or hum that creeps in at this critical stage will be amplified along with the program material and will be audible in the resultant sound. To avoid introducing noise, special pre-selected low noise tubes are used. Hum is usually caused by the 60-cycle AC used to heat the tubes. On all H. H. Scott amplifiers, DC is used instead of AC, so there is no possibility of hum appearing from this source. This DC is derived from the selenium rectifier, SRI, on your LK-48.

In addition to the preamplification, equalization is also accomplished. Equalization involves correcting for the bass cut and treble boost introduced on all phonograph records and prerecorded tapes to allow their manufacture. The equalization characteristic is always within 2 db of the record manufacturer's (RIAA) specification on H. H. Scott amplifiers.

Naturally, any distortion introduced at this first stage would be amplified along with the music in the subsequent stages. To keep distortion down to virtually unmeasurable amounts, negative feedback is employed in every stage of your LK-48.

Feedback is a method whereby part of the output signal is fed back into the input. Negative feedback indicates that the resultant input signal is reduced in strength. While this causes a loss in gain, it also virtually eliminates distortion.

## First Audio Amplifier Stage

The preamplified signal goes to the first audio stage, another duo triode 12AX7 (V3 for Channel A, V4

for Channel B). The signal from tuners, complete tape recorders, crystal cartridges, and other high level program sources being much stronger, bypasses the preamplifier stage and goes directly to this first audio stage. Here the signal is further amplified and modified (if desired) by the tone controls. H. H. Scott uses feedback-type tone controls, giving the advantage of low distortion, of not affecting the midrange response, and of *being flat* when the control is in the flat position (flat position is "O" on the front panel, indicating that there is no tone control boost or attenuation).

The first audio amplifier stage also includes the low-frequency cutoff filter. The human ear cannot hear signals below 20 cycles per second. However, a good turntable or record will contain noises of lower frequency. These noises, which you cannot hear, are capable of being reproduced by the amplifier. Often these subsonic sounds will generate such enormous signals that they will waste much of the amplifier's power and adversely affect its ability to reproduce the desirable program material. The special filter used by H. H. Scott eliminates all these subaudible noises and permits the amplifier to concentrate its power in the audible range of 20 to 20,000 cycles per second.

## Second Audio Stage and Phase Splitter

The pentode-triode 7199 (V5 for Channel A, V6 for Channel B) provides an additional stage of gain, and splits the phase for the push-pull output stage. The advantages of a push-pull output stage are higher power and lower distortion. To obtain the advantages of this system, it is necessary to have some means of inverting the phase of the signal so that one tube in the output stage will be exactly out of phase with the other (in other words — one will be "pushing" while the other is "pulling").

It is also essential that the phase splitter be able to send signals of exactly equal strength to each output tube. In most circuits this is accomplished by having special AC balance controls which can only be set with expensive laboratory equipment. In the LK-48, the AC balance controls are eliminated by using a true self-balancing phase splitter with special matched components. The DC balance controls are easily set by following the simple instructions given. No test equipment is needed. To further reduce distortion, negative feedback is applied to this stage as well.

## Output Stages

Two type 7189 pentodes are used in push-pull for each output stage (Channel A are V7 and V8, Channel

B V9 and V10). The way these output tubes are operated is typical of H. H. Scott standard design procedure. A tube manufacturer usually rates his tubes according to the average amount of heat dissipation they can handle. It is standard procedure for most engineers to use this "design center" in their circuits or even go beyond it to squeeze the maximum amount of power out of their amplifiers regardless of how this may affect tube life. H. H. Scott amplifiers operate all tubes, *particularly* the output tubes, well *below* manufacturer's design center. This assures long tube life and superior performance. On the LK-48 for example, the output tubes are operated at 75% of manufacturer's average.

There are other benefits from this conservative operation of the output tubes. Variations in tubes are not critical. It is not necessary to match the tubes to get low distortion. In addition, bias adjustments are not needed because of the conservative operation. The bias for the output tubes is fixed (as opposed to the less desirable self-biasing of some amplifiers) and is derived from the selenium rectifier, SRI.

The output tubes supply the necessary power to drive the speaker, but unfortunately the output impedance of the tubes will be high, while most speakers are of low impedance. In order to match these impedances, it is necessary to use output transformers. You can have the most elaborate and complicated amplifier circuitry in the world, but you will not have a good amplifier unless you have good output transformers. Unfortunately, good output transformers are very expensive. Two indications of a good output transformer are size and weight. Only a large well-designed transformer can supply low distortion and clean response from the lowest audible frequencies to the highest. The oversize transformers on your LK-48 do just that.

The most conspicuous aspect of an amplifier's performance is its power output. The LK-48 is rated at 24 watts per channel. You may notice that other amplifiers (many less expensive) with smaller transformers also claim similar or greater power. All amplifiers are rated at 1000 cycles, a frequency at which you do not need a particularly good amplifier to get good power measurements. The vital frequencies are those between 20 and 50 cycles. Here is where you need the power, and here is where only quality amplifiers can give it to you.

The Institute of High Fidelity Manufacturers (IHFM) recognized this problem and has evolved a new amplifier measurement — the "power band." Simply, the power band represents the range of frequencies over which the amplifier can supply a specified amount of power at the amplifier's rated distortion. The LK-48 has a power band extending down below 19 cycles and over 25,000 cycles. In fact, at 20 cycles the LK-48 will produce over 28 watts of music power (24 watts, steady state)!! This is a meaningful specification of the performance of this remarkable amplifier.

An amplifier's stability is also important. An amplifier should only reproduce signals fed to it, not originate



signals of its own. Many amplifiers under certain conditions will start to produce a powerful supersonic oscillation. This can happen when the amplifier is used with electrostatic speakers (which act as a capacitive load), or if the amplifier is operated with no speakers attached (no load). In extreme cases this oscillation is capable of burning out an amplifier in a few minutes. H. H. Scott amplifiers, like the LK-48, are completely stable under all conditions — no load, resistive, inductive or capacitive load. This means that if the speaker wire should accidentally be disconnected, you need have no fear of damaging your amplifier.

We have often referred to the desirability of low distortion. A wide frequency response, ample power, and low hum and noise are important but cannot compensate for high distortion. The LK-48 will produce its rated output of 24 watts (IHFM standard) at less than 0.8% total harmonic distortion. This is important, but even more important is the distortion at normal listening levels. Many amplifiers will exhibit reasonably low distortion at full output, but actually turn out to have as much or more distortion at normal listening levels of 1 to 5 watts. This is self-defeating.

At normal listening levels, the total harmonic distor-

tion of the LK-48 is below 0.05%, which means it is so low it cannot be accurately measured with even the finest of laboratory instruments! The translucent sound from your LK-48 is proof of this low distortion.

## Power Supply

In order to supply the necessary voltages to all the stages of the amplifier a rugged power supply is needed. The husky oversize power transformer along with the GZ34/5AR4 rectifier and SRI selenium rectifier comprise the heart of the power supply. An important characteristic of the GZ34 is its slow warmup. This gives the other tubes and components an opportunity to reach normal operating condition before the full force of the high voltages and currents are transmitted by the rectifier. The electrolytics (condenser cans) are all specially designed and conservatively operated. These are other factors in the long life you can expect from the amplifier.

Heat can be a problem in any high power amplifier. Under normal conditions you can expect the amplifier to use about 200 watts of electricity. This will generate a considerable amount of heat. The heat has to be rapidly transferred away from the output stages where most of it is generated. If it is not, the life of the tubes and other components will be greatly curtailed. One of the ways the heat is carried away is by convection to the air. The many holes in the chassis are designed to encourage air circulation which will perform this function. Equally important is the use of electrolytic aluminum for the chassis material.

Most amplifier chassis are steel which is a less expensive material. Unfortunately steel is not a good conductor of heat so such units will have their output stages overheating even though the rest of the amplifier is cool. Aluminum is an excellent conductor of heat, so it rapidly conducts the heat away from output stages to other parts of the chassis where it can be readily transferred to the air.

In fact you may notice that your aluminum front panel is warm to the touch. This means that the heat is being transported away from the heat sources and that your amplifier is operating safely.

Another advantage of the aluminum chassis is that it is nonmagnetic so acts as a shield against induced hum from the power transformer. Conventional chassis made of steel, which is magnetic, are much more prone to this type of difficulty.

## Conclusion

There are many ingredients involved in designing a high quality complete stereo amplifier. However, as this discussion has attempted to show, compromise is not one of them.

# Instruction for the Model LK-48 48 Watt Complete Stereo Amplifier

The LK-48 is a complete two-channel stereo amplifier consisting of dual 24 watt power amplifiers and dual preamplifiers on a single chassis. It employs the same engineering concepts and features that have made H. H. Scott amplifiers the standard in the industry. Conservatively designed, the LK-48 will bring you years of listening pleasure.

**IMPORTANT:** Every effort has been made to insure that this kit, when assembled, will perform perfectly. In order to achieve this result, you must read all of the instructions and follow them precisely. Let us repeat . . . **READ ALL INSTRUCTIONS CAREFULLY . . . FOLLOW THEM EXACTLY.**

## Unpacking your Kit-Pak

Figure 1 demonstrates the step by step procedure in unpacking your kit, as well as the extremely simple procedures involved in setting it up as a convenient work bench. With the Kit-Pak you can work on any table in the house. When it is time to stop working for the evening, all you have to do is close the cover and turn off the soldering iron. Everything is put away in minutes.

You are now ready to begin the construction. After reading these introductory notes, place the instruction booklet into the groove between the cardboard flap and the box cover. In this way the instructions will be in front of you at all times for easy reference.

## Check the parts

On page 47 of this manual is a descriptive list of the parts included. Before beginning the assembly it is recommended that you check all the parts with this list. It will insure that there are no missing parts, and will help you become familiar with the various items. If you should accidentally damage or misplace any parts,

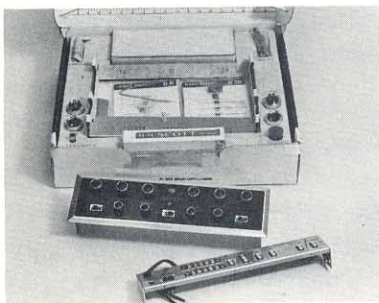

1. Remove front and rear. Pull off knobs to avoid loss.

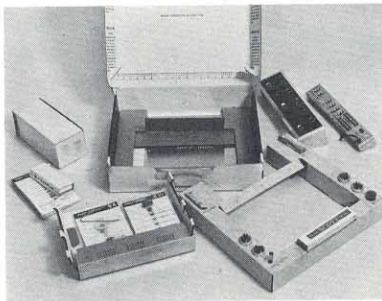

2. Carefully remove the rest of the parts and the white platform.

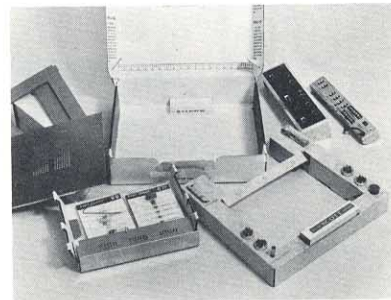

3. Remove brown cardboard pad and bottom cover. Place small tube package in rear of kit-pak bottom.

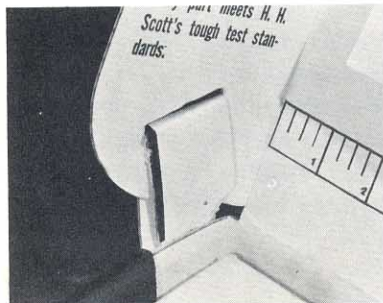

4. Your Kit-Pak cover will hold open when you insert special flap through slit in cover.

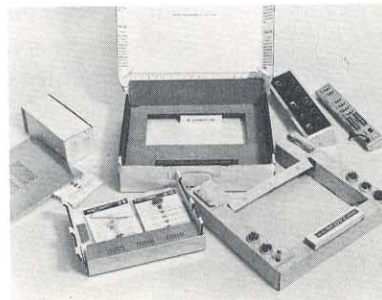

5. Turn over brown cardboard pad and lift up pad in rear.

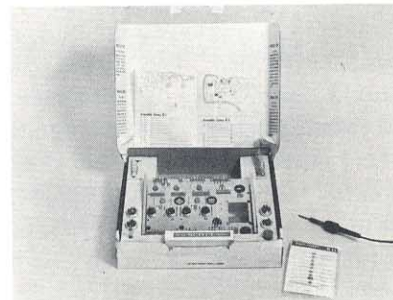

6. Replace white platform. Place chassis in center and instruction booklet behind flap.

**FIGURE 1**

write to the LABORATORY KIT SERVICE DEPARTMENT at the factory immediately.

A four foot length of insulated wire has been supplied. It is to be used to replace any missing wires or ones accidentally damaged. Simply cut off the length required (a convenient ruler is printed on the inside cover) and strip off  $\frac{1}{4}$ " of insulation at each end.

Occasionally we may make minor substitution of parts. Such substitutions are carefully checked and the parts supplied will work as satisfactorily as those specified in the manual. These changes will be obvious and are mentioned here only to prevent confusion in checking the parts list. For example, .005  $\mu$ f. capacitors are used interchangeably with .0047  $\mu$ f. capacitors.

## Tools Required

A small screwdriver is provided. In addition, you will need a pair of long nose pliers, a regular size screwdriver, a pair of wirecutters, and a soldering iron or gun. A 35 watt (or more) pencil type soldering iron is actually the easiest to use. The iron should be supplied with a small tip. If a soldering gun is used, it should also have a small tip, and should be used carefully because of the enormous heat it supplies.

## Simplified soldering and wiring instructions

All the solder needed to assemble the unit is supplied. If for any reason additional solder is needed, make sure that you obtain 60/40 ROSIN CORE SOLDER. Under no circumstances should you use Acid Core solder. **All guarantees are voided if Acid Core solder is used.**

**Here's how to solder joints correctly (see Fig. 2):**

1. Before using the soldering iron or gun, the tip must be tinned for ease of use. First heat up the iron.

Then when the tip is hot, wipe with a cloth till bright and shiny, and apply a generous amount of solder. Remove any excess. Repeat this process for all sides of the tip.

2. Make sure that all leads (wires) and terminals to be soldered are completely clean. Do not use fluxes or paste of any sort.
3. The leads should be mechanically secure before soldering. This does not mean wrapping leads around the contacts several times. It means a single turn around the contact which is then pinched tightly with the long nose pliers. If the wire is too large for bending, position the wire so that a good solder connection can still be made.
4. Leads on resistors, capacitors, and similar components are generally much longer than they need to be to make the indicated connections. In these cases, the excess leads should be cut off before the part is added to the chassis. In general, the leads should be long enough to reach their termination allowing for a little left over to make a good mechanical joint. A very handy way of gauging the length of lead to trim off is to superimpose the capacitor or resistor right on the pictorial. The pictorials are all full scale, so by placing the component over its picture and allowing about  $\frac{1}{4}$ " extra on each end for the mechanical joint, you can shorten the leads quickly and accurately. Sometimes a lead will not seem quite long enough to reach the desired mounting point. In such a case, the terminal lug can be bent slightly to make the connection possible.
5. Place a flat side of the soldering iron tip against the joint to be soldered until it is heated sufficiently to melt the solder.
6. Place the solder against the heated terminal (with the soldering iron still in contact) and it will immediately flow over the joint. Use only enough solder to thoroughly wet the joint. Too much solder

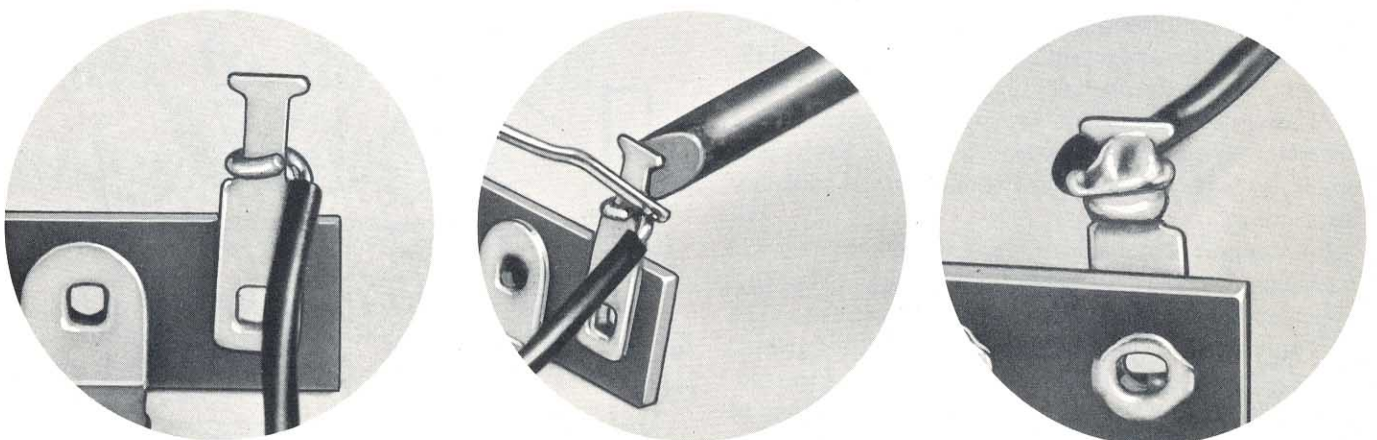

FIGURE 2

may cause short circuits. The soldering iron does not actually come into contact with the solder, only with the joint. It is the heated joint that melts the solder.

7. As soon as sufficient solder has flowed, remove the solder tube and then a second later, the iron. Use care not to move the leads until the joint has hardened (about 5 seconds). A good solder joint should appear to be bright and shiny. Check the joint for rigidity. If it is not firm and tight, reheat the joint and permit the solder *already present* to flow again. Sometimes a little more solder will have to be added.
8. When soldering certain of the components, such as diodes and resistors, it is advisable to use no more heat than is necessary. Excessive heat can damage these components.
9. Keep the soldering iron clean and bright by occasionally wiping with a rag. The iron does not have to be cooled for this purpose.  
If you have never done any soldering before, it would be an excellent idea to practice on scraps of wires before beginning.

## Basic electrical assembly procedure

Your amplifier kit includes three separate sub-assemblies: the front (with all the controls and knobs), the main (with all the tube sockets), and the rear (with all the input and output jacks and terminals). You will construct each sub-assembly separately and then combine them to make a complete amplifier. The symbol *F* refers to the front, *M* to the main, and *R* to the rear.

Each terminal, tube, transformer, etc. has a code number (i.e. T1, V2, and so forth). Every pin on each of these terminals, or tube sockets is also numbered (i.e. pin 1, pin 2, and so forth). The instructions will call for a wire to be connected to pin 3, V4, for example. With the instructions will be a pictorial, clearly showing in full color the connection to be made and its location. With this information you should experience no difficulty in making the correct connection.

A series of Part-Charts are provided with all the necessary resistors and capacitors mounted. Each chart applies to a particular page of the electrical assembly instructions.

For example — in the instructions that follow you will find a page marked “Assembly Group BF-4.” The “B” indicates that this is part of the electrical assembly. The “F” indicates that you will be working on the “front.” The “4” means that this is the fourth page of instructions for electrical assembly of the front. In the bag of Part-Charts, you will find a Part-Chart BF-4. Take this out and keep it next to you when working on this page. The first step on the page is called BF4-1 and refers to a 270K resistor. The first part on the Part-Chart is a 270K

resistor. The pictorial on the top of the page will show exactly where this part will go. The part is mounted as directed and the step is checked off as completed.

The many wires used in the amplifier kit are packed in a small plastic envelope. This envelope contains three separate bundles, clearly marked. For example — Assembly Group BF-1 involves connecting a group of wires of different colors and lengths. Open the bundle of wires marked “front,” and spread them out near you. The first step, BF1-1, calls for a 4” yellow wire. From the yellow wires select the ones of the appropriate length and hold them up to the ruler printed on the inside cover of the Kit-Pak. Once you have the correct one, you may proceed as above.

**IT IS IMPORTANT TO POSITION THE WIRES OR COMPONENTS IN THE SAME POSITION AS SHOWN IN THE PICTORIAL.**

If the symbol — (S-) appears in the instructions after any connection, it means that the particular connection with all other wires on the same pin, should be soldered. After the “S” will appear a number. This number indicates exactly how many leads or wires are supposed to be connected to the terminal or pin in question. For example: connect an orange wire to pin 2, V6 (S-3). The soldering number (S-3) will always be printed in red, so it can be found quickly. It indicates that there should be 3 wires or leads (including the orange one) connected to pin 2, V6, and that all three of them are to be soldered. This provides an additional check for wiring errors.

Do not solder any connection that is not marked with an (S-). Other connections are yet to be made to this pin before it can be soldered. Frequently one end of a lead or component will be soldered while the other end will not (for the moment). The (S-) will only appear after the description of the end that is to be soldered. After completing the soldering, cross out the (S-) symbol with your pencil indicating that it has been done.



This is in addition to checking off each step. In this way you can glance over the assembly instructions and spot any (S-) that has not been crossed out, indicating that you may have overlooked a joint to be soldered.

The instructions which follow have been arranged in a logical order to insure perfect results. Follow them exactly, checking off each step as completed.

For easy reference keep this instruction manual on the inside of the top cover of your KIT-PAK as shown in Fig. 1.

## Types of Wire Provided

**Regular hook-up wire** — These are the standard insulated wires that you will be using most of the time. They will be found in bundles for the different portions of the assembly procedure.

**Buss wire** — This is a term used to describe short pieces of uninsulated wire. A bundle of buss wire will be found in one of the hardware bags.

**Mic Lapel** — This is a type of cable which has one insulated length and one uninsulated length of buss wire inside. The cable itself has a brightly colored outside insulation.

**Conductive Vinyl** — This is large hollow tubing, usually either black or white in color, which has a hollow tube of conductive material inside. Between the outer layer of insulation and the inner layer of conductive material is a single strand of uninsulated buss wire. When using this cable, it is important to prevent the inner conductive material from becoming exposed and causing a short circuit. Always keep the outer insulation completely over it.

**Conductive Cable (ESS)** — This is hollow tube with a black or white outer insulation and a spiral metal shield inside.

**Spaghetti** — A common name to describe hollow black insulation material. This tubing is slipped over bare wires to provide protection.

## What to do if you make a mistake

No matter how careful you may be, it is still possible to break something accidentally or to cut a lead too short. We might add that if you work when tired, or try to do too much, too fast, then the possibility of mishap increases greatly. Nevertheless, it is easy to correct most common errors.

**1. Cutting a wire or lead too short** — If you cut the wire from one of the components too short you can easily correct it by taking a small piece of uninsulated wire (buss wire) and splicing it on as shown in Fig. 3.

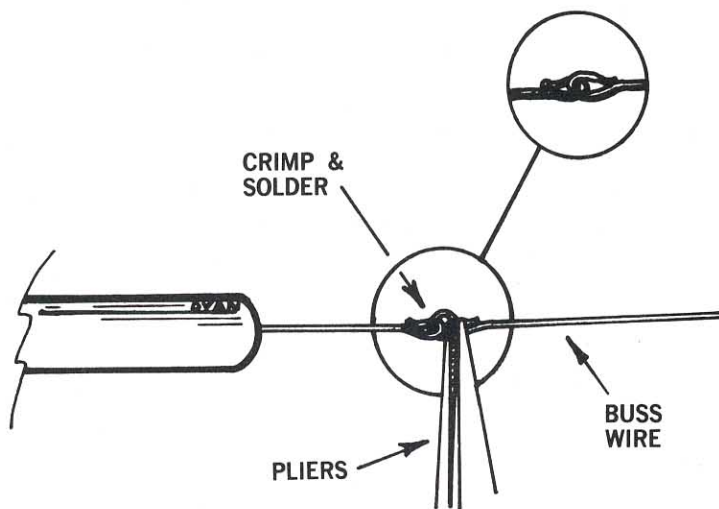
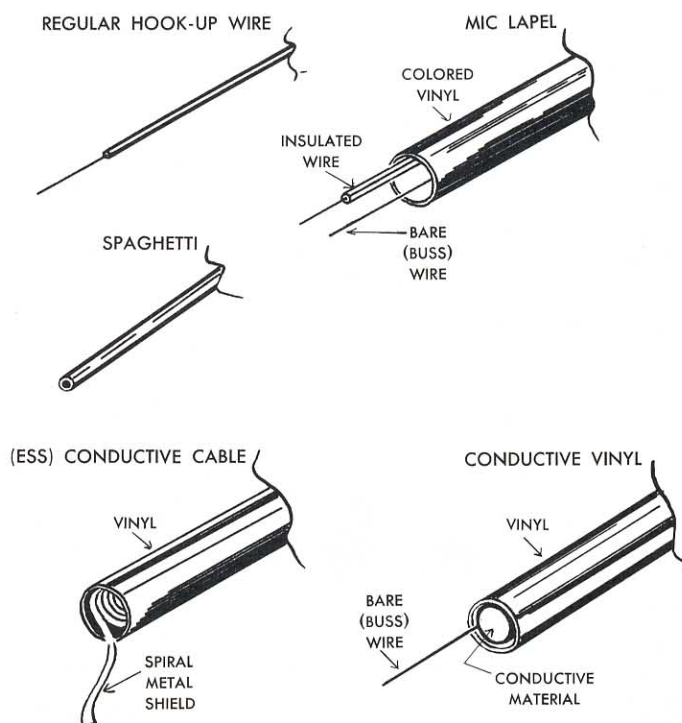

FIGURE 3

If a wire supplied is damaged, you can cut off a replacement from the 4 feet of spare wire supplied.

**2. Breaking a terminal strip** — The terminal strips are quite sturdy and will withstand a great deal of handling. Nevertheless, if you are extremely rough, a terminal pin can be broken off. If this happens, make all connections to the small hole below the broken pin. Be careful to avoid having any of the bare wires touch the chassis. If the phenolic material cracks but does not break off, you can continue on as the wires themselves will keep the broken piece in place.

In the unlikely circumstance that the entire terminal strip breaks off, it is necessary to replace it. Write to the parts department at the factory for a replacement. Drill out the rivet holding the broken strip, using a number 28 drill. Mount the replacement with a regular 6-32 x 1/4" machine screw, lockwasher, and nut.



# Mechanical Assembly Group A-1

Read each step completely before performing the operation specified. Check off each step as it is completed. The parts needed in the following will be found in a small envelope.

A1-1. Take the rear chassis and mount the fuse post into the hole marked "2 1/2 A Slo-Blo." The fuse post can be identified by the word "fuse" printed on the cap. Mount the post as shown in Figure 4, with the terminal on the side as shown. Bend up this terminal slightly to simplify connections. Take one of the fuses provided (one is a spare), unscrew the cap of the fuse post and insert the fuse into the cap. Then put the fuse into the post, push in the cap and rotate it clockwise in order to fasten securely.

A1-2. Chart AM-1 shows the location of all the parts on the bottom of the main chassis, so refer to this chart for all succeeding mechanical assembly steps. Mount the SRI underneath in the space provided, using the special clip (see Figure 5). Make certain that the lettering and numbers are face up and that the plus and minus signs are towards the front of the main chassis.

A1-3. Mount the three large condenser cans C1, C2, and C3 (C1 is a CEC4 x 75/75, C2 is 2 x 20, 2 x 25, and C3 is a CEC4 x 20/450) in the space indicated on chart AM-1. Position the cans so that the little symbols stamped or punched on the bottom of the cans (triangle, square, semi-circle, etc.) are in exactly the same position as shown on the chart. After the cans have been mounted, lock them in by turning the lugs 90 degrees with your long nose pliers (see Figure 6).

A1-4. Mount the RWS-1 (large white stand-up resistor) by inserting from the top of the chassis and positioning as shown in Figure 7. Use the small #6 machine screw with lock nut.

A1-5. Locate the small hole identified as P5 on top of the chassis. Take one of the small potentiometers with the identifying mark RCV 100K-P etched in very small letters on the side. Insert the pot into the hole P5 from the bottom of the chassis. Make sure the locating lug lines up with the small hole next to P5. Push the pot up into the hole with your thumbs, applying sufficient pressure for the prongs near the top of the pot to spring open and catch on the top side of the chassis. See Fig. 8.

A1-6. Mount the remaining RCV-100K-P (P6) in the same manner.

A1-7. Install four rubber grommets in the 4 holes marked "X" on chart AM-1.

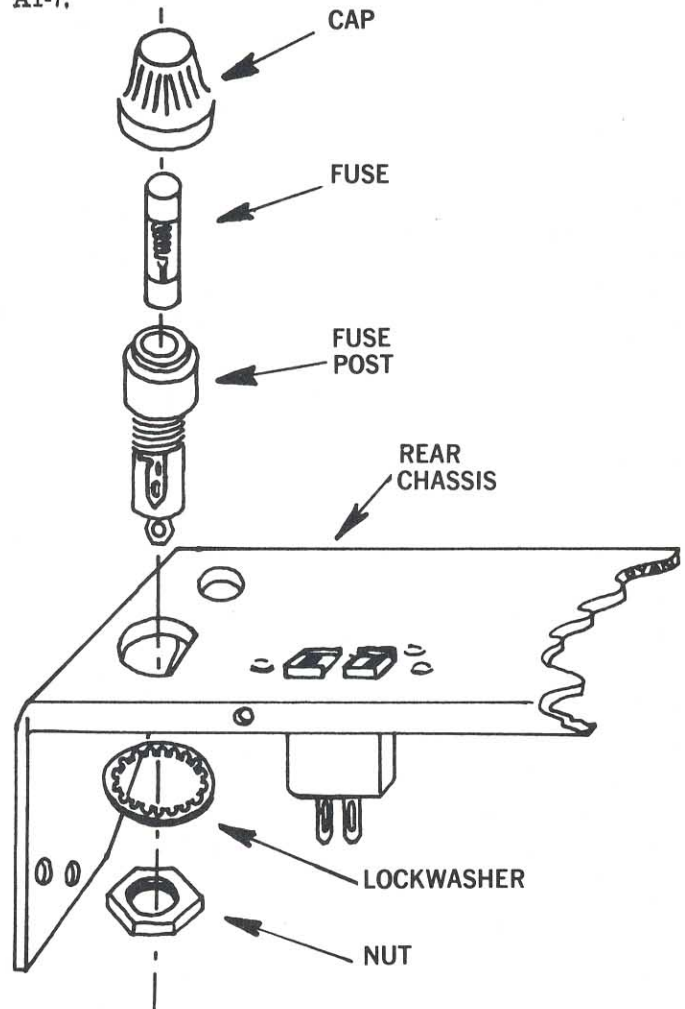

FIGURE 4

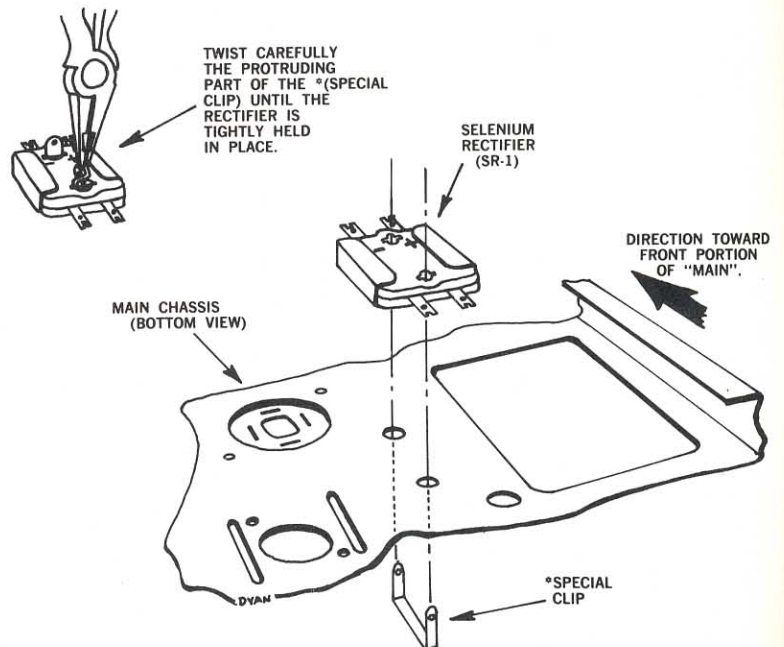

FIGURE 5

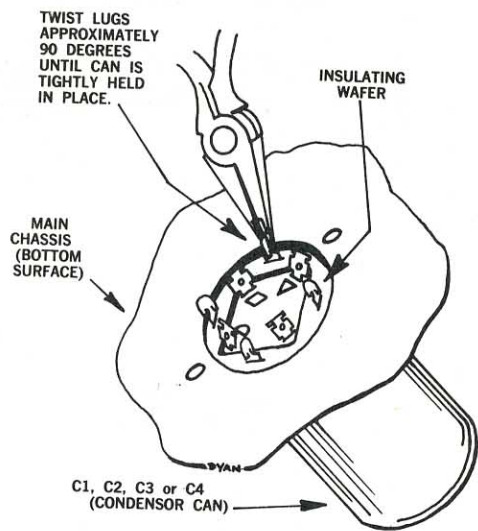

FIGURE 6

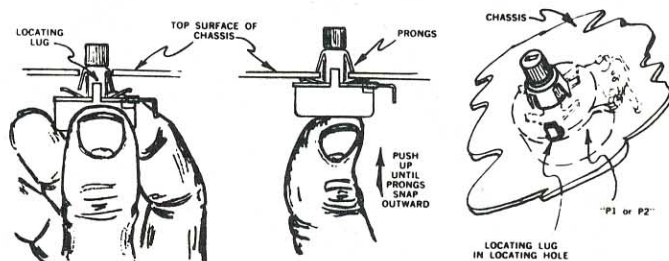

FIGURE 8

# Electrical Assembly

## INTRODUCTORY NOTES

To obtain the really fine performance this amplifier is capable of, all lead lengths from components (resistors and capacitors) must be as short as possible. Follow the diagrams closely. Keep all parts as close to the chassis as possible. This refers to all components and insulated wires. Bare wires, of course, should not touch the chassis, unless instructions indicate otherwise.

The biggest source of mishaps, next to poorly soldered joints, is short circuits. A short circuit occurs when two uninsulated wires that are not supposed to, accidentally touch each other. It can also happen when a wire going towards one pin accidentally touches another pin or the metal chassis nearby. The main body of a resistor or a capacitor is fully insulated so it does not matter if this part touches something. It is only the bare wires on the ends that you have to watch for. As the number of parts in the amplifier starts to increase, you will realize how possible it is for short circuits to occur.

Extra quantities of black insulation material (spaghetti) have been supplied. Whenever you suspect that a short circuit may occur (either to the chassis, to another bare wire, or to another pin), slide a small piece of spaghetti over the bare wires in question. If you position the parts exactly as shown in the pictorials, you will not need to use spaghetti very frequently. However, it is better to be on the safe side if you have any doubts.

Check off each step as soon as it is completed. Cross off each (S) as soon as the soldering required is done. Connect your soldering iron now so that it will be ready.

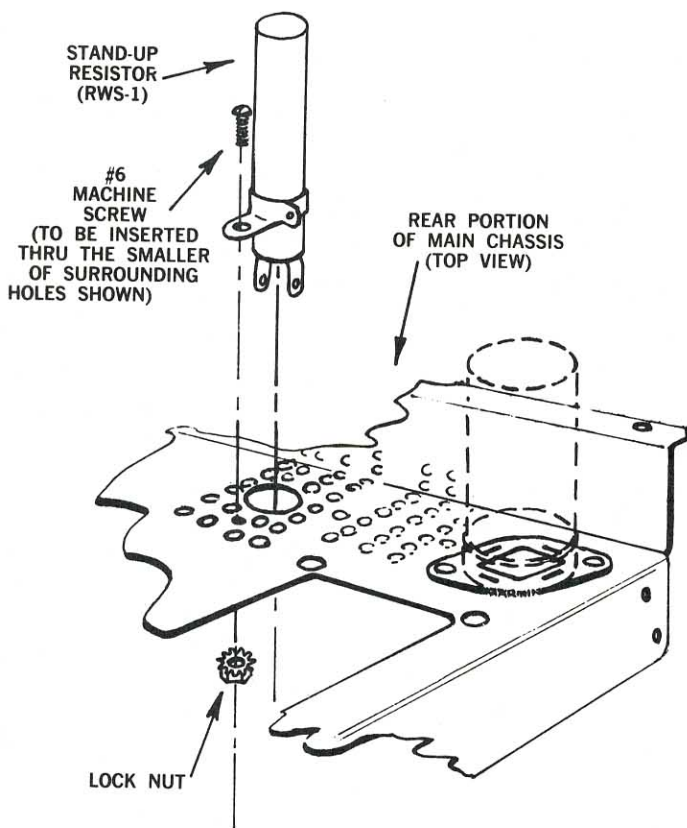
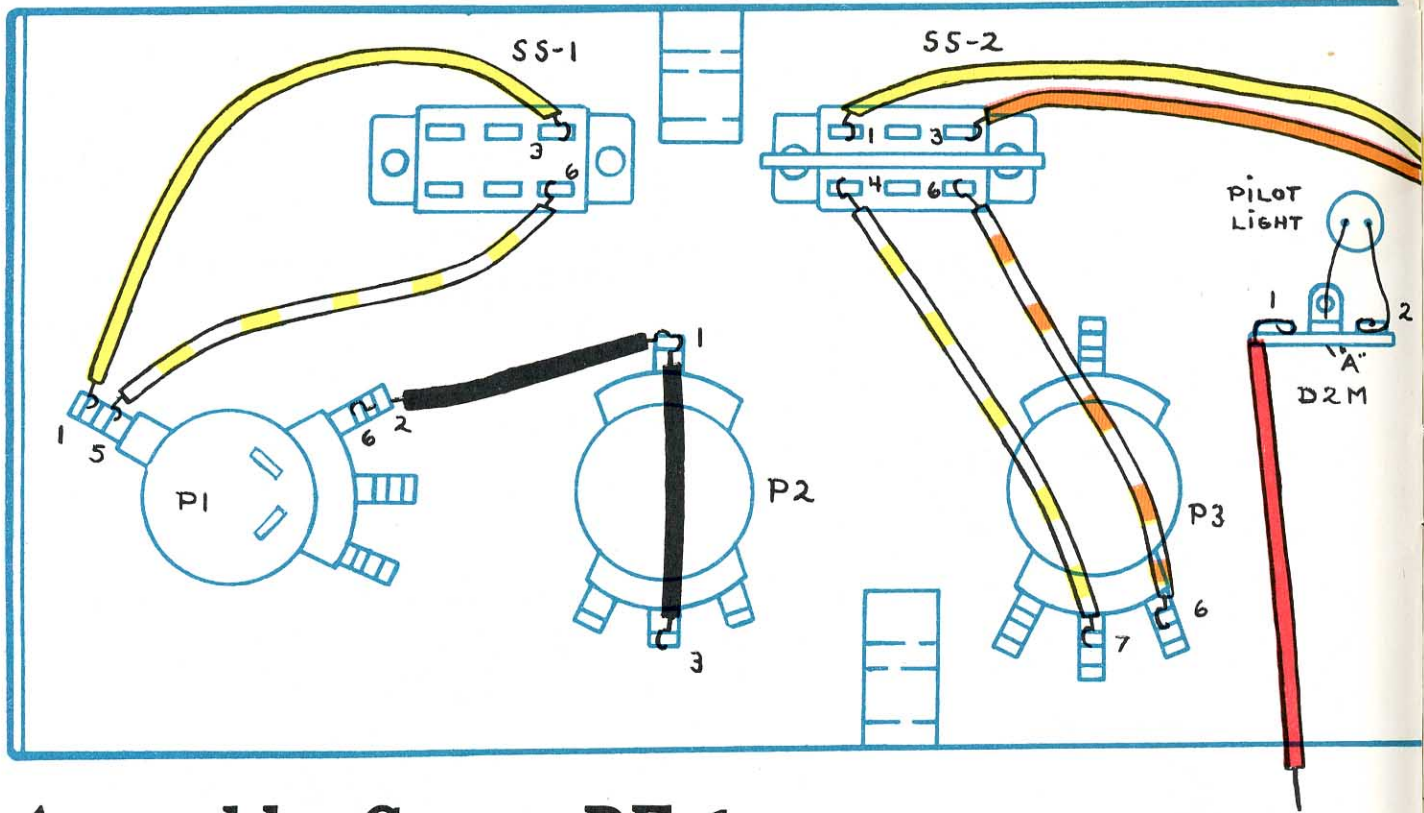

FIGURE 7



## Assembly Group BF-1

There is an envelope of wires supplied. Open this envelope and spread out the wires for the "front" near you. Several of the controls (like P1) have two decks. Some of the pins are on the bottom deck and some on the top. To avoid confusion, the word top or bottom will be inserted after the pin number to insure that you will connect to the right pin. Remember, do not solder unless you see the solder instructions (in red).

- BF1-1. Connect a 4" yellow wire from Pin 3, SS1 (S1) to Pin 1 (bottom), P1.
- BF1-2. Connect a 3 1/2" yellow/white wire from Pin 6, SS1 (S1) to Pin 5 (top), P1.
- BF1-3. Connect a 3" black wire to Pin 1, P2. Strip an extra 1/2" of insulation from the other end. Pass this end through Pin 2\* (bottom), P1, and connect to Pin 6 (top), P1.
- BF1-4. Connect a 2" black wire from Pin 1, P2 (S2) to Pin 3, P2.
- BF1-5. Connect a 3 1/2" yellow/white wire from Pin 4, SS2 to Pin 7 (top), P3.
- BF1-6. Connect a 3 1/2" orange/white wire from Pin 6, SS-2 (S1) to Pin 6 (top), P3.
- BF1-7. Connect a 7 3/4" yellow wire from Pin 1, SS2 to Pin 7 (top), P4.
- BF1-8. Connect a 7 1/2" orange wire from Pin 3, SS2 (S1) to Pin 6 (top), P4.
- BF1-9. Connect one of the bare wires from the pilot light to Pin 2, D2M, connect the other one to ground lug "A" D2M (S1).
- BF1-10. Connect a 5 1/2" orange/white wire from Pin 4, SS3 (S1) to Pin 5, SW2.
- BF1-11. Connect a 6" orange wire from Pin 1, SS3 (S1) to Pin 11, SW2.
- BF1-12. Connect a 4" black wire from Pin 3, SW1 to Pin 6, SW2.

\*Wire fed *through* a pin counts as *two* leads to the pin, not *one*.

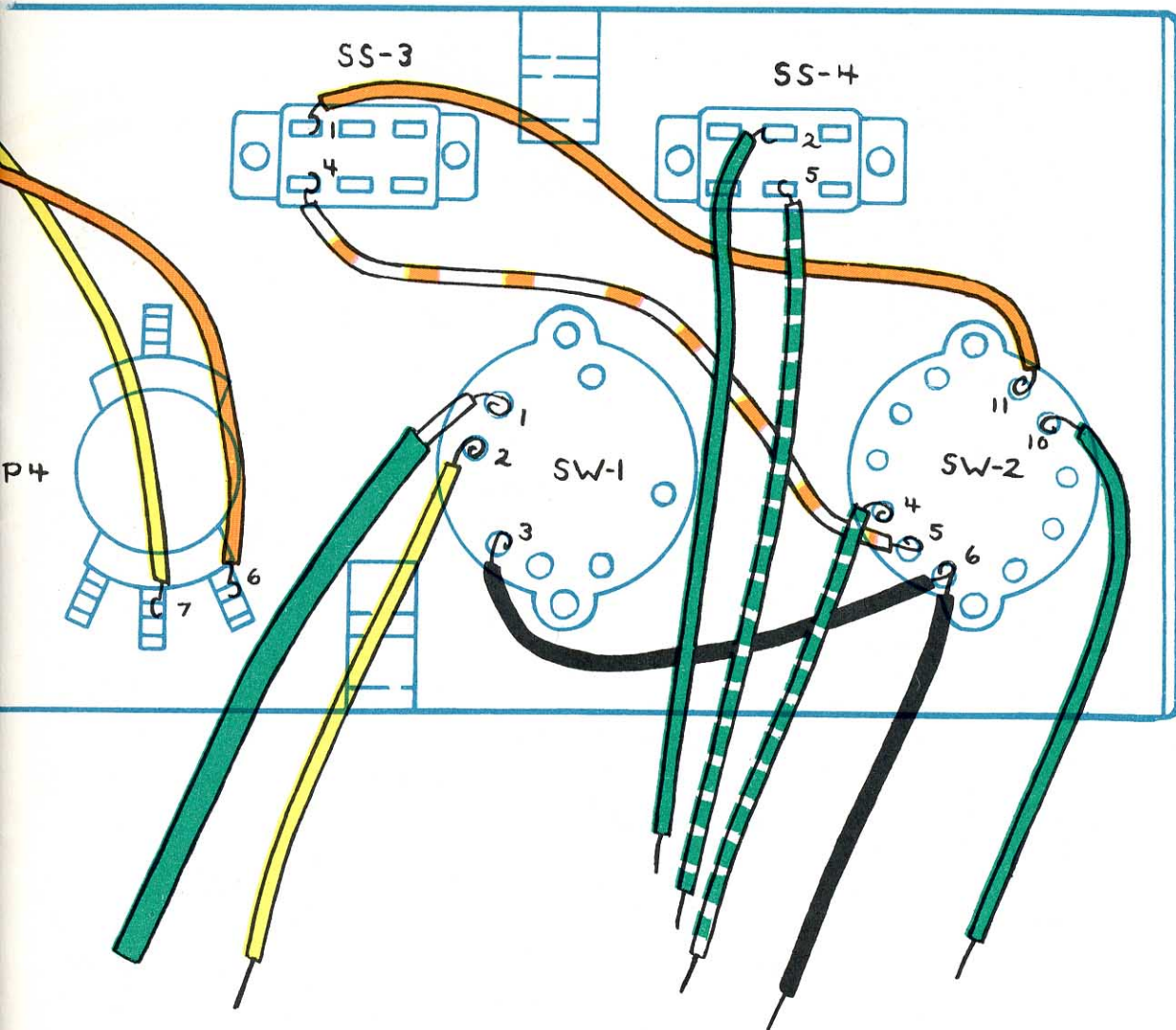

The two switches SW1 and SW2 have several lugs which are double (such as Pins 1 and 2 on SW1). Whenever a wire is to be connected to any of these double lugs, make sure that it is securely attached and soldered to both lugs. Only one end of all wires used in this group will be connected at this time. The other ends will not be connected until later on. When soldering a lug, make sure that *all* wires going to the lug are fully soldered.

- BF1-13. Connect a 3 ¼" black wire to Pin 6, SW2.
- BF1-14. Connect a 5" green/white wire to Pin 4, SW2 (S1).
- BF1-15. Connect a 5" green wire to Pin 10, SW2 (S1).
- BF1-16. Connect a 4" green wire to Pin 2, SS4.
- BF1-17. Connect a 5 ½" green/white wire to Pin 5, SS4.
- BF1-18. Clip out the bare wire at one end of an 8 ¼" green mic lapel (see page 7 for description) and connect this end to Pin 1, SW1.
- BF1-19. Connect a 4" yellow wire to Pin 2, SW1.
- BF1-20. Connect a 6" red wire to Pin 1, D2M.

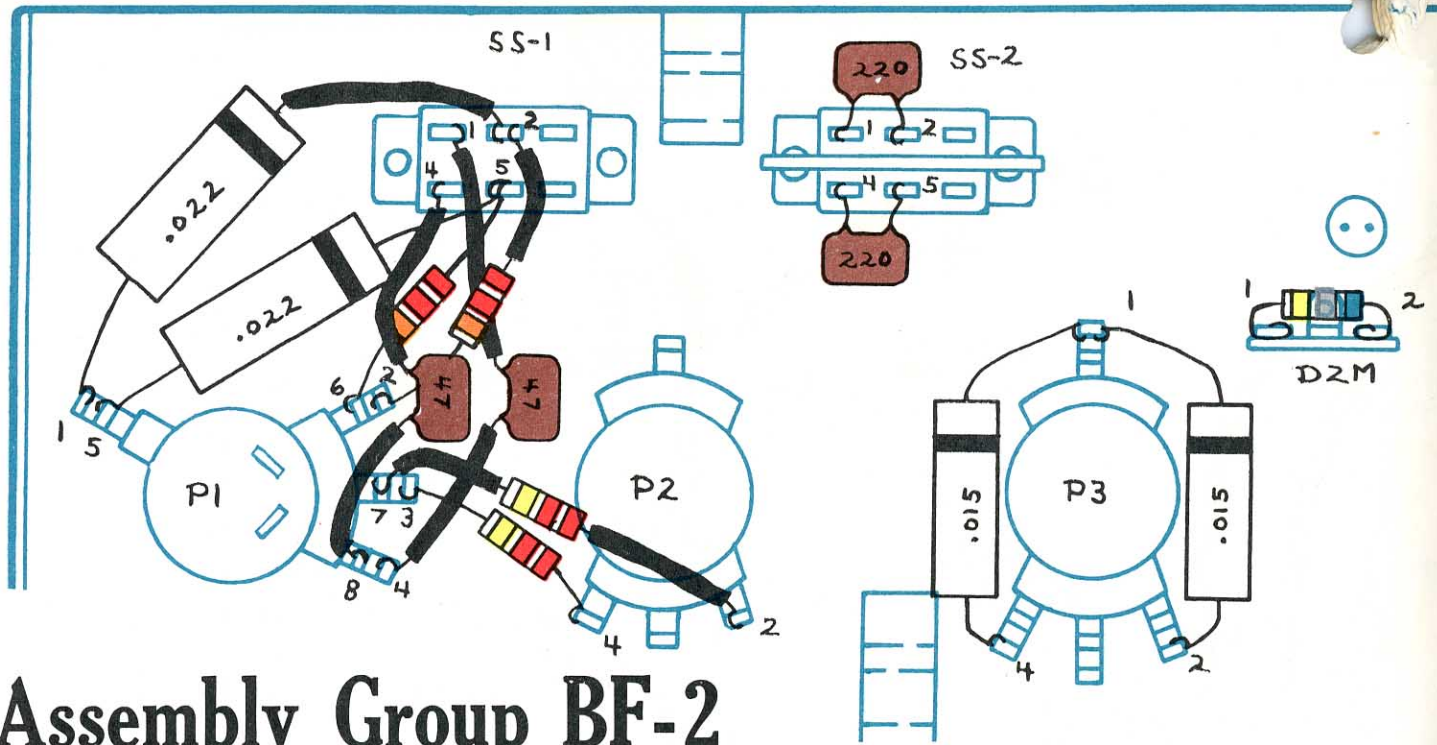

## Assembly Group BF-2

A part chart for this group is included. Keep all leads short and make very small mechanical joints. If you wrap too much wire around the terminals when making your mechanical joints, you may very well have a piece sticking out that will cause a short circuit. As before, insure that uninsulated wires are not touching the metal covers on the controls, the metal chassis, or other uninsulated wires or terminals.

- BF2-1. Add a 1" piece of black insulation (spaghetti)\* to each end of a CM47 and connect from Pin 1, SS1 (S1) to Pin 4 (bottom), P1.
- BF2-2. Add a 1" piece of black insulation to the black band end of a CPM .022 and connect to Pin 2, SS1. Connect the other end to Pin 1 (bottom), P1 (S2).
- BF2-3. Connect the black band end of a CPM .022 to Pin 5, SS1. Connect the other end to Pin 5 (top), P1 (S2).
- BF2-4. Add a 1" piece of black insulation to one end of a 22K resistor (red, red, orange). Connect this end to Pin 2, SS1 (S2). Connect the other end to Pin 2 (bottom), P1 (S3).
- BF2-5. Connect a 22K resistor (red, red, orange) from Pin 5, SS1 (S2) to Pin 6 (top), P1 (S2).
- BF2-6. Add a 3/4" piece of black insulation to each end of a CM47 and connect from Pin 4, SS1 (S1) to Pin 8 (top), P1.
- BF2-7. Connect a 220K resistor (red, red, yellow) from Pin 3 (bottom), P1 (S1) to Pin 4, P2.
- BF2-8. Add a 3/4" piece of black insulation to each end of a 220K resistor (red, red, yellow). Connect from Pin 7 (top), P1 (S1) to Pin 2, P2.

\*A roll of spaghetti will be found in the hardware bag.

## Assembly Group BF-3

- BF3-1. Connect a CM 220 from Pin 1, SS2 (S2) to Pin 2, SS2 (S1).
- BF3-2. Connect a CM 220 from Pin 4, SS2 (S2) to Pin 5, SS2 (S1).
- BF3-3. Connect the black band end of a CPM .015 to Pin 1 (bottom), P3. Connect the other end to Pin 4 (bottom), P3.
- BF3-4. Connect the black band end of a CPM .015 to Pin 1 (bottom), P3 (S2). Connect the other end to Pin 2 (bottom), P3.

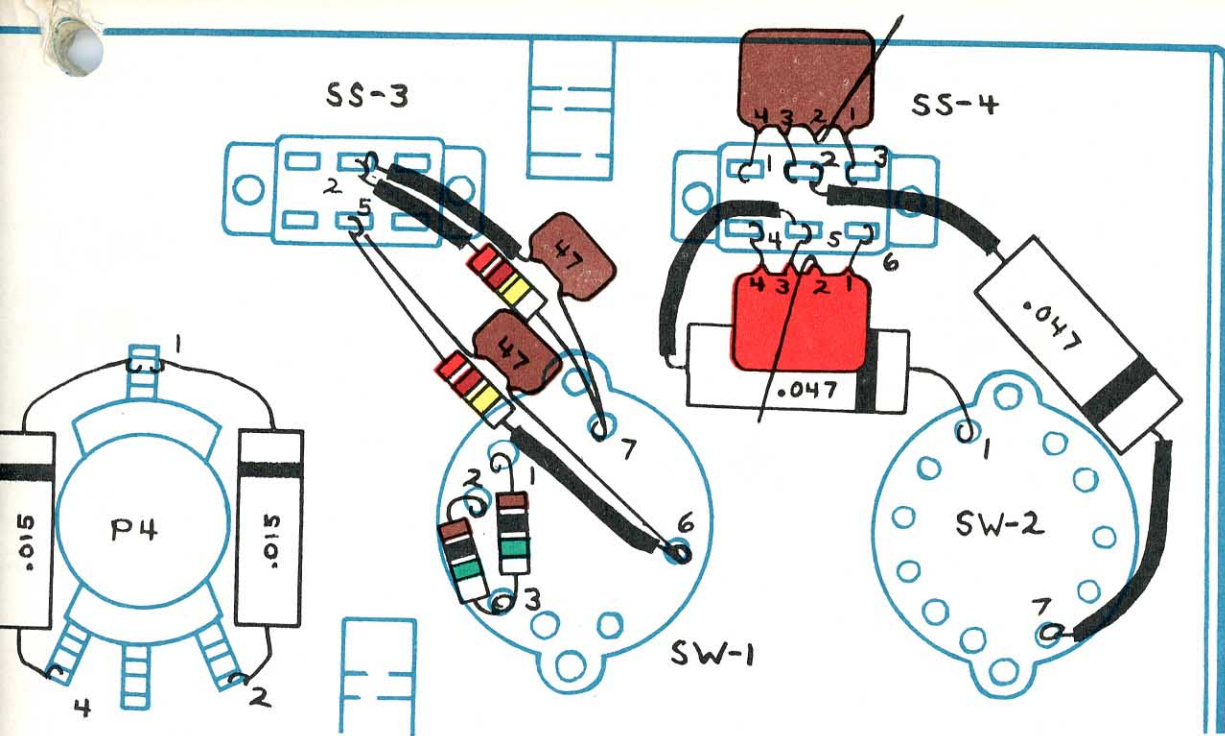

- BF3-5. Connect a 680K resistor (blue, grey, yellow) from Pin 1, D2M (S2) to Pin 2, D2M (S2).
- BF3-6. Connect the black band end of a CPM .015 to Pin 1 (bottom), P4. Connect the other end to Pin 4 (bottom), P4.
- BF3-7. Connect the black band end of a CPM .015 to Pin 1 (bottom), P4 (S2). Connect the other end to Pin 2 (bottom), P4.
- BF3-8. Connect a 1M resistor (brown, black, green) from Pin 1, SW1 (S2) to Pin 3, SW1.
- BF3-9. Connect a 1M resistor (brown, black, green) from Pin 2, SW1 (S2) to Pin 3, SW1 (S3).

## Assembly Group BF-4

From here on you will be soldering pins that have several wires attached. When you solder these pins, make sure that *all* the wires connected to the pin are fully soldered.

- BF4-1. Add a 1¼" piece of black insulation to one end of a 270K resistor (red, purple, yellow). Connect this end to Pin 6, SW1. Connect the other end to Pin 5, SS3.
- BF4-2. Connect a CM47 from Pin 5, SS3 (S2) to Pin 6, SW1 (S2).
- BF4-3. Add a ¾" piece of black insulation to one end of a 270K resistor (red, purple, yellow) and connect this end to Pin 2, SS3. Connect the other end to Pin 7, SW1.
- BF4-4. Add a ¾" piece of black insulation to one end of a CM47 and connect this end to Pin 2, SS3 (S2). Connect the other end to Pin 7, SW1 (S2).
- BF4-5. Add a 1" piece of black insulation to the end of a CPM .047 without the black band. Connect this end to Pin 5, SS4. Connect the black band end to Pin 1, SW2 (S1).
- BF4-6. Add a 1¼" piece of black insulation to each end of a CPM .047. Connect the black band end to Pin 7, SW2 (S1). Connect the other end to Pin 2, SS4.
- BF4-7. Connect lead 1 of the red PEC to Pin 6, SS4 (S1). Do not connect lead 2 at this time. Connect lead 3 to Pin 5, SS4 (S3) and lead 4 to Pin 4, SS4 (S1).
- BF4-8. Connect lead 1 of the brown PEC to Pin 3, SS4 (S1). Do not connect lead 2 at this time. Connect lead 3 to Pin 2, SS4 (S3) and lead 4 to Pin 1, SS4 (S1).

You have now completed most of the electrical assembly on the front. It is now time to check your work. Take out chart AF1 and follow instructions given on page 38. concerning double checking. You will note that on chart AF1 some pins have circled numbers next to them. The circled number indicates that more wires will be connected to this pin later. For double checking at this time only refer to numbers not circled.

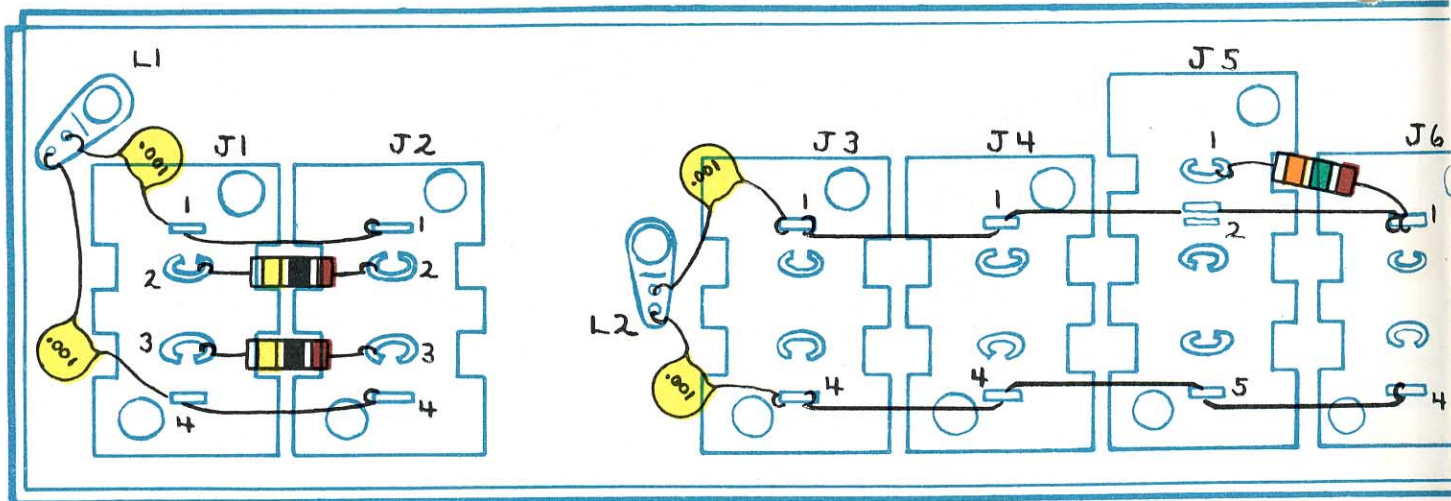

# Assembly Group BR-1

In these next few pages, you will be assembling the rear. When connecting wires to Pins 2 or 3 of J1, J2, J3, J4, J5, or J6, it is suggested that you use the hole on the very top. This will make it easier for you to insert audio cables to your completed amplifier.

- BR1-1. Connect a 4½" buss wire from Pin 1, J3, through Pin 1, J4 (S2)\* through Pin 2, J5 (S2)\* to Pin 1, J6.
- BR1-2. Connect a 4½" buss wire from Pin 4, J3, through Pin 4, J4 (S2)\* through Pin 5, J5 (S2)\* to Pin 4, J6.
- BR1-3. Connect a 2" buss wire from Pin 1, TB1 to Pin 1, TB2.
- BR1-4. Connect one end of a CC .001 to L1. Run the other end through Pin 1, J1 (S2)\* to Pin 1, J2.
- BR1-5. Connect one end of a CC .001 to L1 (S2). Run the other end through Pin 4, J1 (S2)\* to Pin 4, J2.
- BR1-6. Connect a 100K resistor (brown, black, yellow) from Pin 2, J1 (S1) to Pin 2, J2.
- BR1-7. Connect a 100K resistor (brown, black, yellow) from Pin 3, J1 (S1) to Pin 3, J2.
- BR1-8. Connect a CC .001 from L2 to Pin 1, J3.
- BR1-9. Connect a CC .001 from L2 (S2) to Pin 4, J3.
- BR1-10. Connect a 15K resistor (brown, green, orange) from Pin 1, J5 to Pin 1, J6.
- BR1-11. Connect one end of a CC .005 to L3. Run the other end through Pin 1, TB1\* to Pin 2, TB1 (S1).
- BR1-12. Connect one end of a CC .005 to L3 (S2). Run the other end through Pin 1, TB2 (S3)\* to Pin 2, TB2 (S1).
- BR1-13. Connect an 82K resistor (grey, red, orange) from Pin 3, TB1 to Pin 1, D2A.
- BR1-14. Connect an 82K resistor (grey, red, orange) from Pin 3, TB2 to Pin 1, D2A.
- BR1-15. Connect a CC .01M from Pin 2, AC1 to Pin 1, on the tip of the fuse post.

\*Wire fed *through* a pin counts as *two* leads to the pin, not *one*.

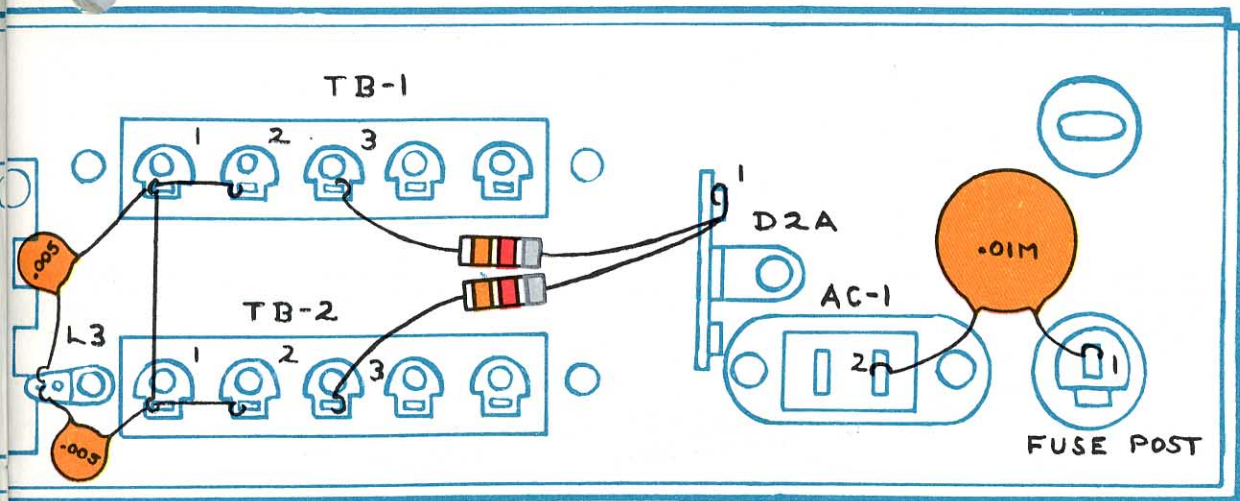

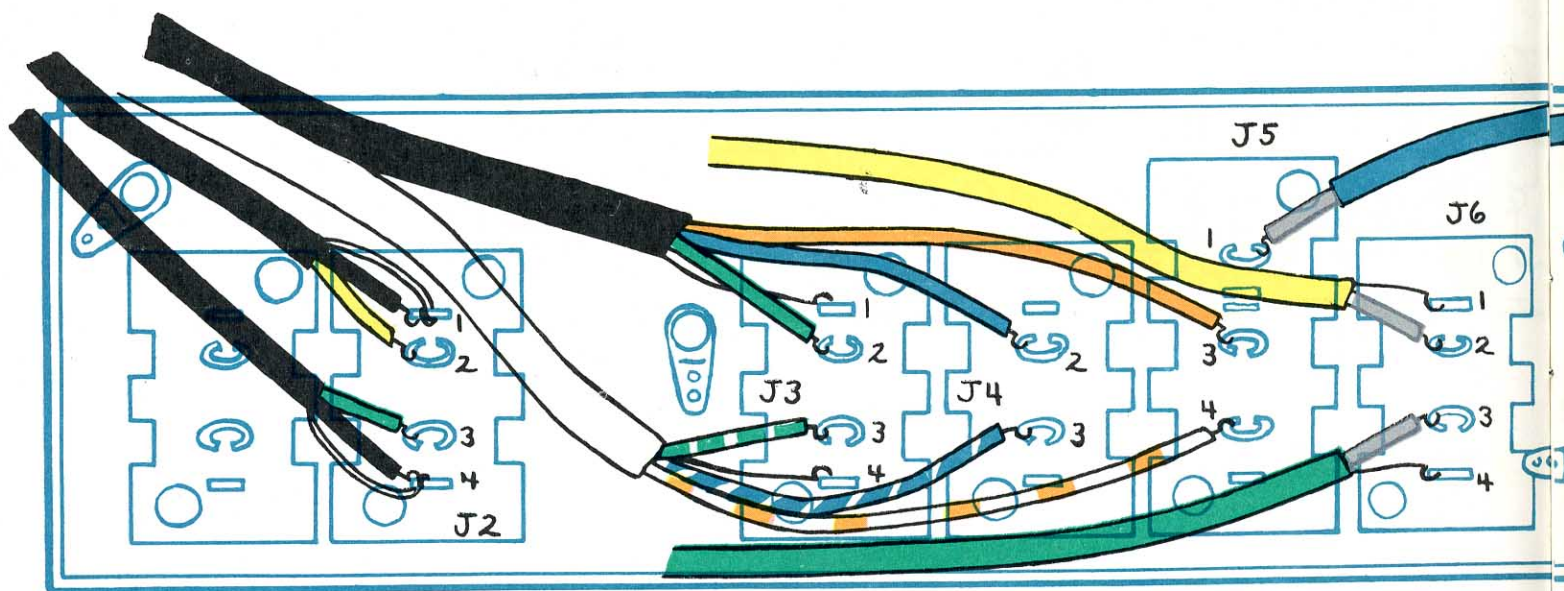

## Assembly Group BR-2

- BR2-1.** Place a 12½" black shielded cable (ESS type. See page 7 for a description.) over a 15" yellow wire and a 13¾" black wire. On the ends of the cable you will observe that there is a metal shield inside the black insulation. On *one end only* take your long nose pliers and carefully unwrap about ½" of this metal shield. Take a little nylon sleeve, slide it over the yellow and black wire and into the cable at this end. See Fig. 9. Connect the yellow wire to Pin 2, J2 (S2). Connect the black wire and the spiral shield to Pin 1, J2 (S3). Do not connect the other end.
- BR2-2.** Place a 12" black shielded cable over a 14¾" green wire and a 13¾" black wire. Unwrap about ½" of the shield. Insert nylon sleeve as in Step BR2-1 above. Connect the green wire to Pin 3, J2 (S2). Connect the black wire and the shield to Pin 4, J2 (S3). Do not connect other end.
- BR2-3.** Place a 14" piece of black conductive tubing (conductive vinyl. See page 7 for a description.) over an 18" orange wire, a 16½" blue wire and a 16" green wire. Connect the orange wire to Pin 3, J5 (S1), the blue one to Pin 2, J4 (S1), the green to Pin 2, J3 (S1) and the bare wire to Pin 1, J3 (S3).
- BR2-4.** Place a 14¼" piece of white conductive tubing (conductive vinyl) over an 18" orange/white wire, a 17¼" blue/white wire, and a 16½" green/white wire. Connect the orange/white wire to Pin 4, J5 (S1), the blue/white wire to Pin 3, J4 (S1), the green/white to Pin 3, J3 (S1) and the bare wire to Pin 4, J3 ( )
- BR2-5.** Connect the insulated wire of a 22¼" yellow mic lapel to Pin 2, J6 (S1). Connect the bare wire at this end to Pin 1, J6 (S3). Do not connect other end.
- BR2-6.** Connect the insulated wire of a 22" green mic lapel to Pin 3, J6 (S1). Connect the bare wire at this end to Pin 4, J6 (S2). Do not connect other end.
- BR2-7.** Clip out the bare wire at one end of a 7¼" blue mic lapel. Connect the insulated wire at this end to Pin 1, J5 (S2). Connect the insulated wire at the other end to Pin 1, D2A (S3) and the bare wire to ground lug "A", D2A (S1).

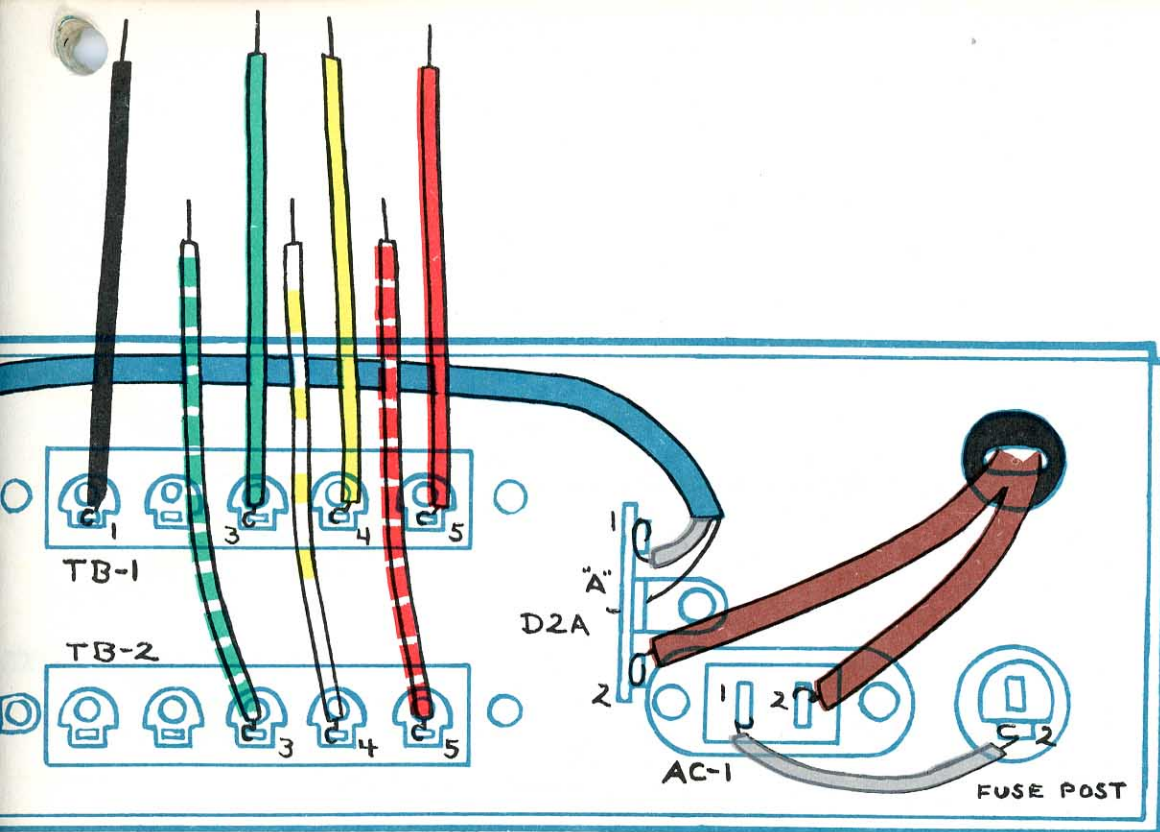

- BR2-8. Connect a 3¼" heavy grey wire from Pin 1, AC1 (S1) to Pin 2, on the fuse post.
  - BR2-9. Connect one of the line cord wires to Pin 2, D2A. Connect the other one to Pin 2, AC1.
- (The following wires are connected at one end only.)
- BR2-10. Connect a 10¼" red wire to Pin 5, TB1 (S1).
  - BR2-11. Connect a 9½" yellow wire to Pin 4, TB1 (S1).
  - BR2-12. Connect a 9" green wire to Pin 3, TB1 (S2).
  - BR2-13. Connect a 6¾" black wire to Pin 1, TB1 (S4).
  - BR2-14. Connect a 6½" red/white wire to Pin 5, TB2 (S1).
  - BR2-15. Connect a 5¾" yellow/white wire to Pin 4, TB2 (S1).
  - BR2-16. Connect a 5¼" green/white wire to Pin 3, TB2 (S2).

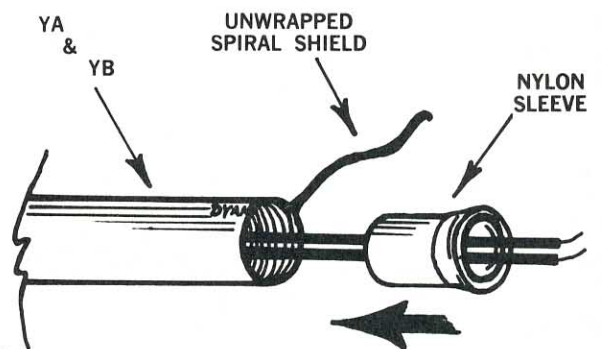

**FIGURE 9**

You have completed most of the work on the rear. Double-check your work, using Chart AR1 as per instructions on page 38.

# Mechanical Assembly Group A-2

- A2-1. Assemble the front to the main as shown, using six of the 6 x 1/4 sheet metal screws provided (these are the shorter of the two sizes provided). To insert the screws properly, you will need a fairly good size screwdriver. Don't be afraid to push down hard on sheet metal screws to get them started. The wire clip is mounted on top of the chassis to hold the heavy cables, referred to below, in place. See Fig. 10.
- A2-2. The next step involves assembling the rear to the main. Before proceeding it is important to determine the proper position and destination of the many long cables connected to the rear. All of the wires except the two heavy cables, one black and one white, should be positioned straight down to avoid interference with the assembly. The two heavy cables are to be fed through the appropriate cutout in the back. See Fig. 11.

Sit the main in front of you with its back facing you. You will observe that there is a metal shield along the back. At one end of this there are two slits as shown. The two heavy cables will be fed through the top slit. Some of the other cables will be fed through the bottom slit later. Carefully

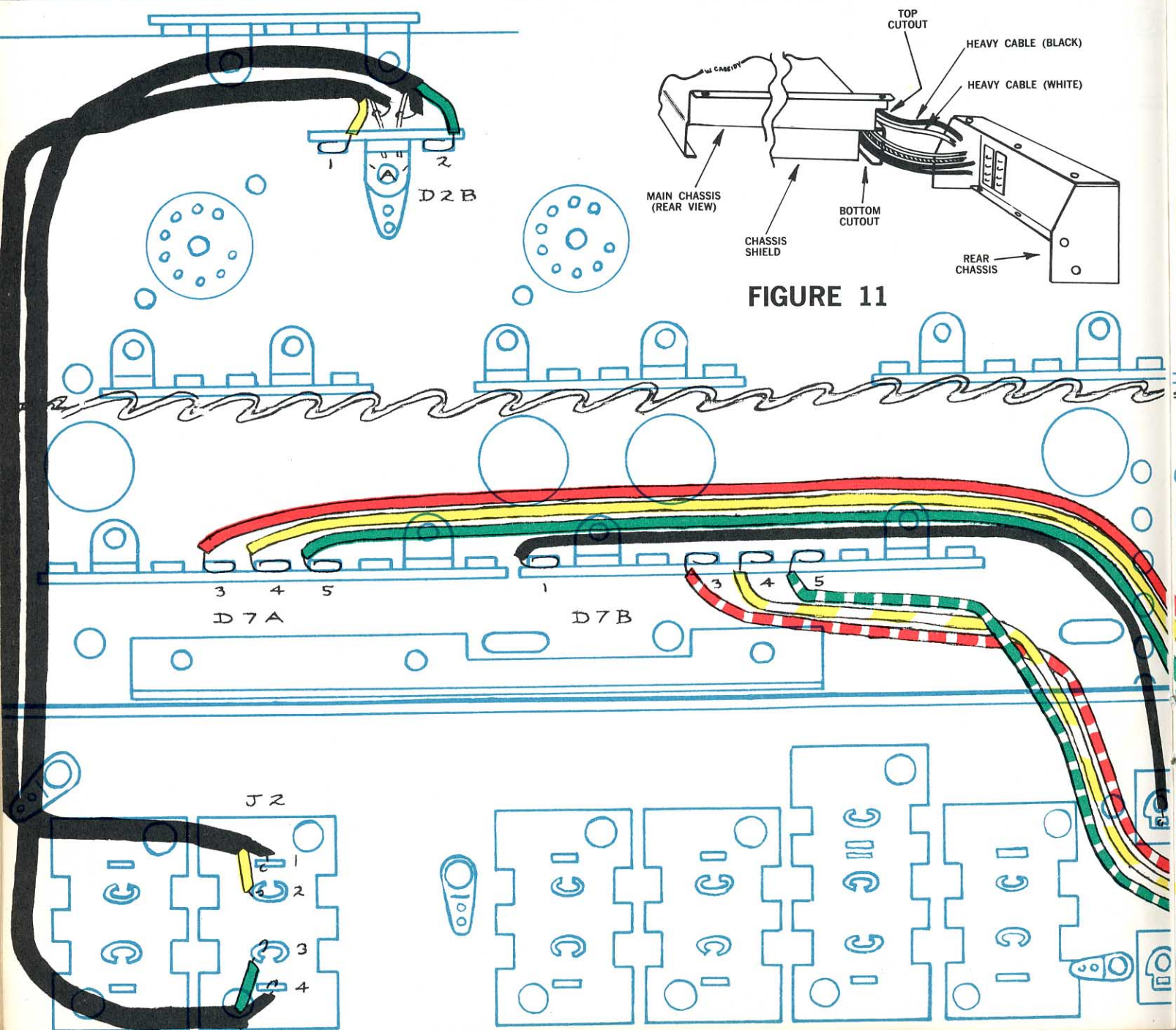

FIGURE 11

position the heavy cables as described and *then* attach the rear to the main with 6 of the shorter 6 x 1/4 sheet metal screws and one bronze 6 x 1/4 sheet metal screw. The bronze screw will be the one in the middle on the top of the rear chassis. Position the cables so they are held in place by the clip discussed above. See Fig. 12.

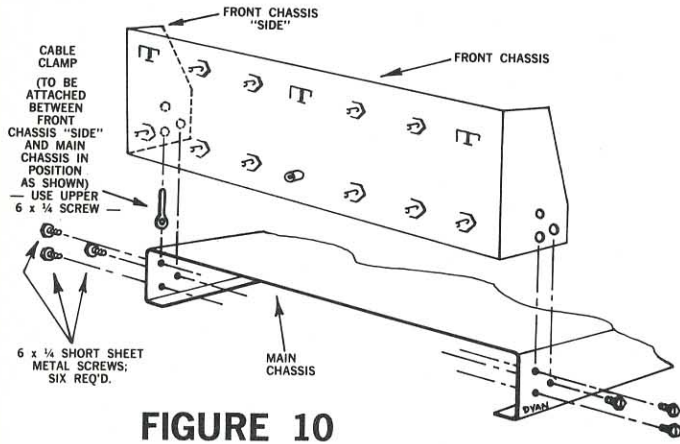
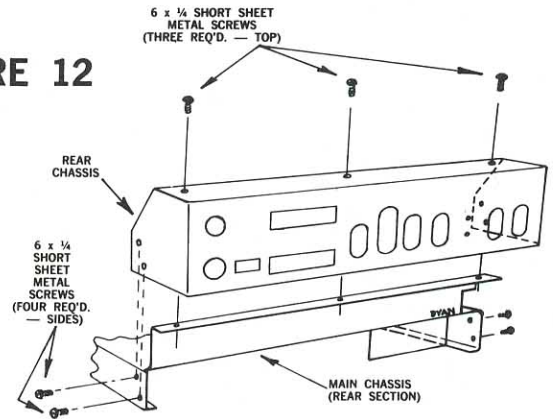

FIGURE 10

FIGURE 12



# Assembly Group BM-1

Position the chassis in front of you as shown in the pictorial. Feed the two long black cables coming from the jacks on the left side of the rear through the slit in the metal shield separating the rear from the main. Position the cables along the extreme left side of the main chassis as shown.

- BM1-1. Unwrap about 3/4" of spiral shield from the end of the black cable (ESS) containing the yellow and black wires. Insert nylon sleeve. Wrap the uninsulated part of the black wire around the shield and solder (S1). (See Fig. 13.) Connect the yellow wire to Pin 1, D2B and the shield to ground lug "A", D2B.
- BM1-2. Unwrap about 3/4" of spiral shield from the end of the black cable containing the green and black wires. Insert nylon sleeve. Wrap the uninsulated portion of the black wire around the shield and solder (S1). (See Fig. 13.) Connect the green wire to Pin 2, D2B. Connect the shield to ground lug "A", D2B.

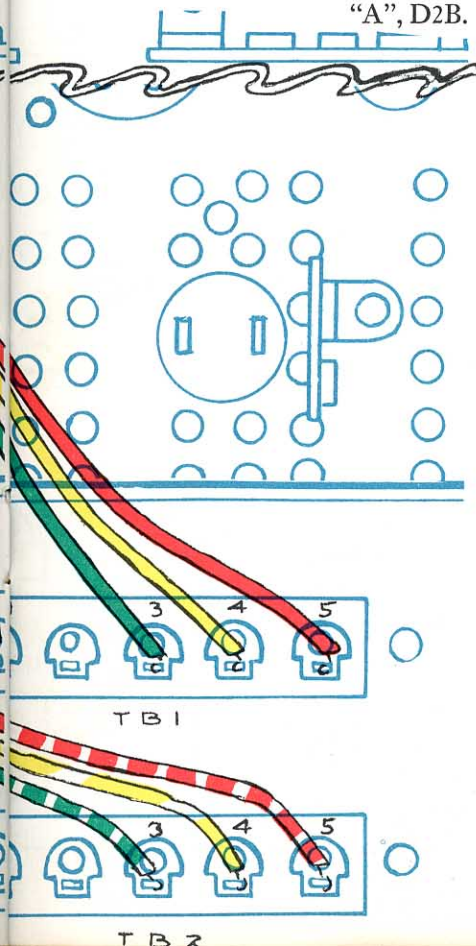

- BM1-3. Connect the red wire coming from Pin 5, TB1, to Pin 3, D7A.
- BM1-4. Connect the yellow wire coming from Pin 4, TB1, to Pin 4, D7A.
- BM1-5. Connect the green wire coming from Pin 3, TB1, to Pin 5, D7A.
- BM1-6. Connect the black wire coming from Pin 1, TB1, to Pin 1, D7B.
- BM1-7. Connect the red/white wire coming from Pin 5, TB2, to Pin 3, D7B.
- BM1-8. Connect the yellow/white wire coming from Pin 4, TB2, to Pin 4, D7B.
- BM1-9. Connect the green/white wire coming from Pin 3, TB2, to Pin 5, D7B.

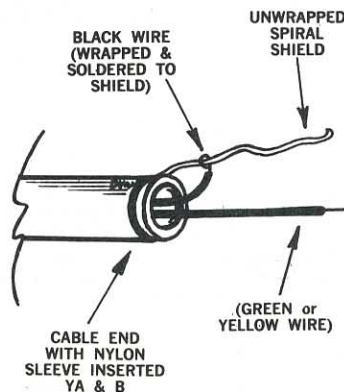
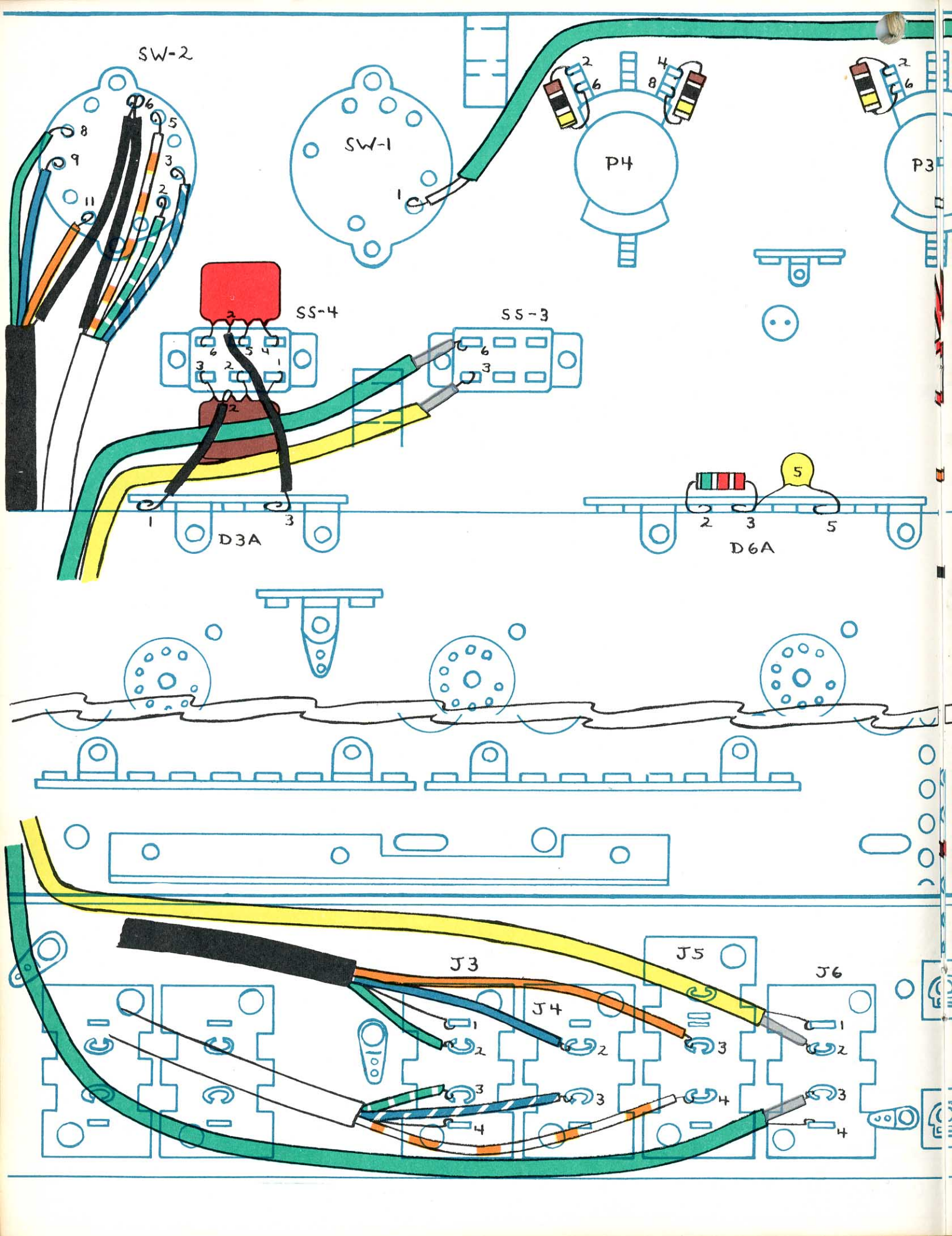
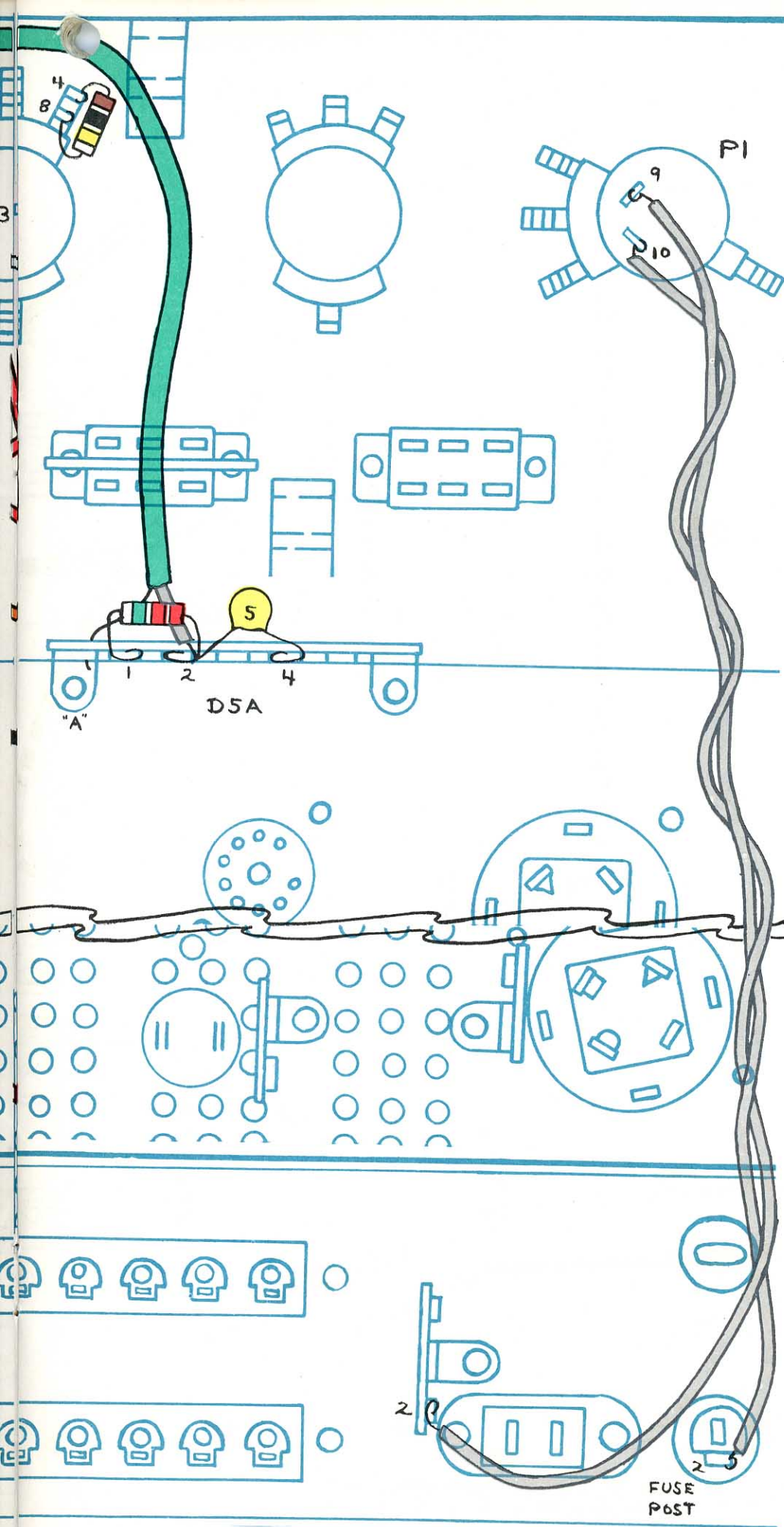

FIGURE 13



# Assembly Group BM-2

Take the assembled chassis and position it with the underside facing up. Place it so the rear is towards you and the front is away. The heavy cables which were placed on the other side of the chassis should be positioned so that their ends can be connected to the front. Once again, make sure that wires going to double lugs on the switches pass through *both* lugs.



**BM2-1.** Locate heavy black cable. Connect the green wire to Pin 8, SW2 (S1). The blue wire to Pin 9, SW2 (S1), and the orange wire to Pin 11, SW2 (S2). Add a 1" piece of black insulation to the buss wire and connect to Pin 6, SW2.

**BM2-2.** Locate heavy white cable. Connect the orange/white wire to Pin 5, SW2 (S2), the blue/white wire to Pin 3, SW2 (S1), and the green/white wire to Pin 2, SW2 (S1). Add a 3/4" piece of black insulation to the buss wire and connect to Pin 6, SW2 (S4).

**BM2-3.** Add a 2 3/4" piece of black insulation to lead 2 of the brown PEC that is connected to Pins 1, 2 and 3 of SS4. Connect to Pin 1, D3A.

**BM2-4.** Add a 2 3/4" piece of black insulation to lead 2 of the red PEC that is connected to Pins 4, 5 and 6 of SS4. Connect to Pin 3, D3A.

**BM2-5.** Clip out the bare wire at the end of the yellow mic lapel coming from J6 and connect the insulated wire to Pin 3, SS3 (S1).

**BM2-6.** Clip out the bare wire at the end of the green mic lapel coming from J6 and connect the insulated wire to Pin 6, SS3 (S1).

**BM2-7.** Connect the insulated wire at the end of the green mic lapel coming from SW1 to Pin 2, D5A. Connect the bare wire at this end to ground lug "A", D5A (S1).

**BM2-8.** Connect a 13 1/2" heavy grey wire to Pin 10, P1 (S1). Connect another 12 1/2" heavy grey wire to Pin 9, P1 (S1). Twist together and connect the longer one to Pin 2, D2A (S2) and the other one to Pin 2, on the fuse post (S2).

**BM2-9.** Connect a 100K resistor (brown, black, yellow) from Pin 2 (bottom), P4 (S2) to Pin 6 (top), P4.

**BM2-10.** Connect a 100K resistor (brown, black, yellow) from Pin 4 (bottom), P4 (S2) to Pin 8 (top), P4.

**BM2-11.** Connect a 100K resistor (brown, black, yellow) from Pin 2 (bottom), P3 (S2) to Pin 6 (top), P3.

**BM2-12.** Connect a 100K resistor (brown, black, yellow) from Pin 4 (bottom), P3 (S2) to Pin 8 (top), P3.

**BM2-13.** Connect a 2.2M resistor (red, red, green) from Pin 2, D6A to Pin 3, D6A.

**BM2-14.** Connect a CC 5 from Pin 3, D6A to Pin 5, D6A.

**BM2-15.** Connect a 2.2M resistor (red, red, green) from Pin 1, D5A to Pin 2, D5A.

**BM2-16.** Connect a CC 5 from Pin 2, D5A to Pin 4, D5A.

# Assembly Group BM-3

- BM3-1. Connect the green/white wire coming from Pin 5, SS4 to Pin 1, D6A.
- BM3-2. Connect the green wire coming from Pin 2, SS4 to Pin 2, D3A.
- BM3-3. Connect the green wire coming from Pin 10, SW2 to Pin 2, V1.
- BM3-4. Connect the green/white wire coming from Pin 4, SW2 to Pin 2, V2.
- BM3-5. Connect the black wire coming from Pin 6, SW2 to ground lug "A", D2B (S3).
- BM3-6. Connect the yellow wire coming from Pin 2, SW1 to Pin 3, D6A.
- BM3-7. Connect a 3½" blue wire from Pin 6 (top), P4 (S3) to Pin 6, D6A.
- BM3-8. Connect a ¾" yellow wire from Pin 7 (top), P4 (S2) to Pin 5, D6A.
- BM3-9. Connect a 3" orange wire from Pin 3 (bottom), P4 (S1) to Pin 4, D6A.
- BM3-10. Connect a 2" white wire from Pin 8 (top), P4 (S2) to Pin 2, D6A.
- BM3-11. Connect the red wire coming from Pin 1, D2M to Pin 1, D3D.
- BM3-12. Connect a 4" blue/white wire from Pin 6 (top), P3 (S3) to Pin 5, D5A.
- BM3-13. Connect a ¾" yellow/white wire from Pin 7 (top), P3 (S2) to Pin 4, D5A.
- BM3-14. Connect a 3" orange/white wire from Pin 3 (bottom), P3 (S1) to Pin 3, D5A.
- BM3-15. Connect a 1¾" white wire from Pin 8 (top), P3 (S2) to Pin 1, D5A.
- BM3-16. Connect a 7" blue wire from Pin 6, D6A to Pin 4 (bottom), P1 (S2).
- BM3-17. Connect a 3" blue/white wire from Pin 5, D5A to Pin 8 (top), P1 (S2).
- BM3-18. Connect a 5¼" black wire from Pin 3, P2 to Pin 2, D3D.
- BM3-19. Connect the insulated wire at one end of a 9" green mic lapel to Pin 2, P2 (S2). Connect the bare wire at this end to Pin 3, P2. Clip out the bare wire at the other end and connect the insulated wire to Pin 7, V6 (S1).
- BM3-20. Connect the insulated wire at one end of a 12¾" yellow mic lapel to Pin 4, P2 (S2). Connect the bare wire at this end to Pin 3, P2 (S4). Clip out the bare wire at the other end and connect the insulated wire to Pin 7, V5 (S1).

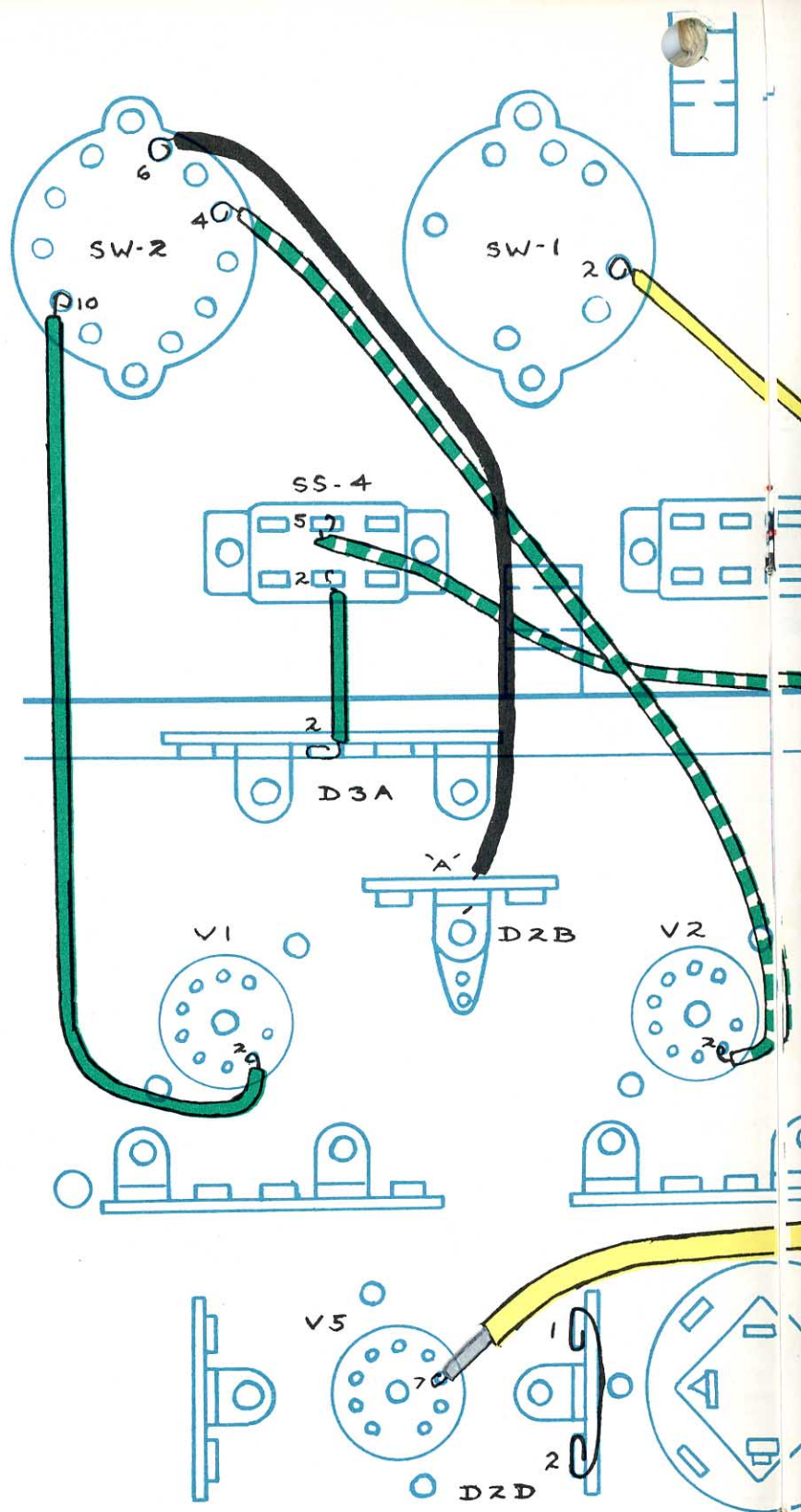

- BM3-21. Connect a 1½" buss wire from Pin 1, D2D to Pin 2, D2D.
- BM3-22. Connect a 1½" buss wire from Pin 1, D2F to Pin 2, D2F.

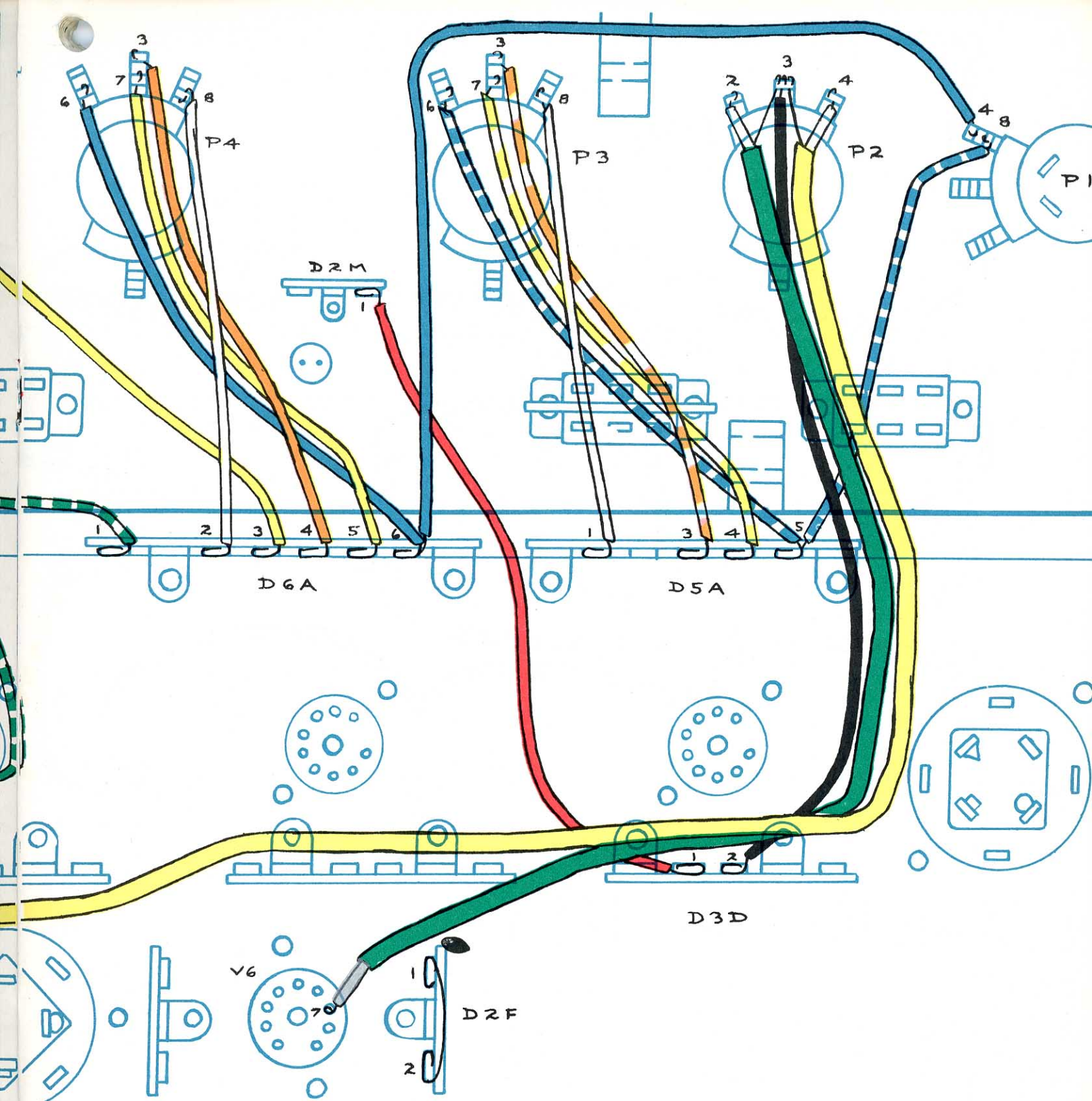

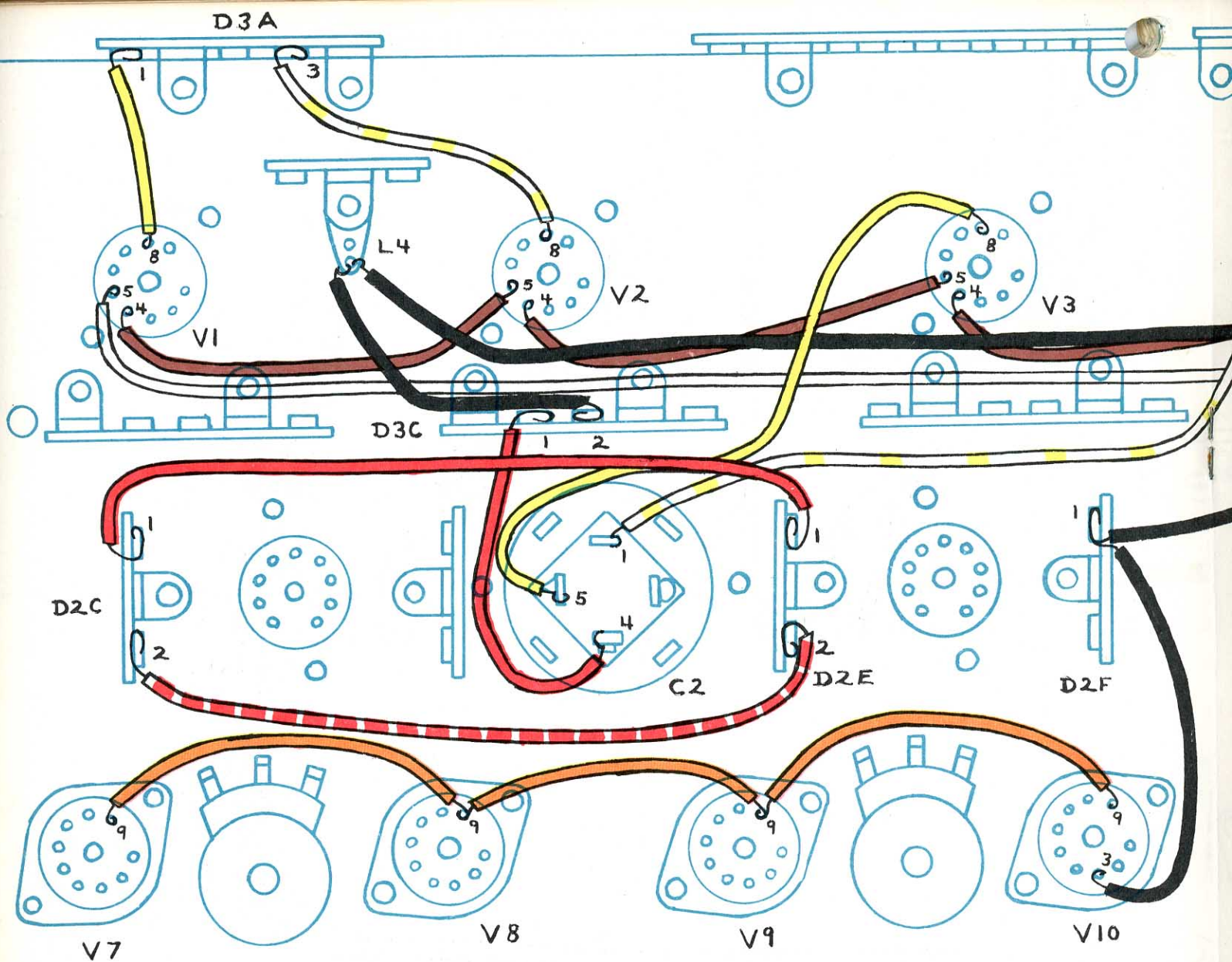

## Assembly Group BM-4

You will begin to make connections to the terminal pins on the small tube sockets. Be very careful with your mechanical joints so that the wire going to one pin does not cause a short circuit by accidentally touching a neighboring pin. You will also find yourself soldering terminal pins which are very close to other wires and components. To avoid damage, move the wires and components slightly aside during the soldering process. When the soldering is done you can then reposition all the parts.

- BM4-1.** Connect a 2¼" yellow wire from Pin 1, D3A (S2) to Pin 8, V1.
- BM4-2.** Connect a 3½" yellow/white wire from Pin 3, D3A (S2) to Pin 8, V2.
- BM4-3.** Connect a 3½" brown wire from Pin 4, V1 (S1) to Pin 5, V2 (S1).
- BM4-4.** Connect a 3¾" brown wire from Pin 4, V2 (S1) to Pin 5, V3 (S1).
- BM4-5.** Connect a 3½" brown wire from Pin 4, V3 (S1) to Pin 5, V4 (S1).

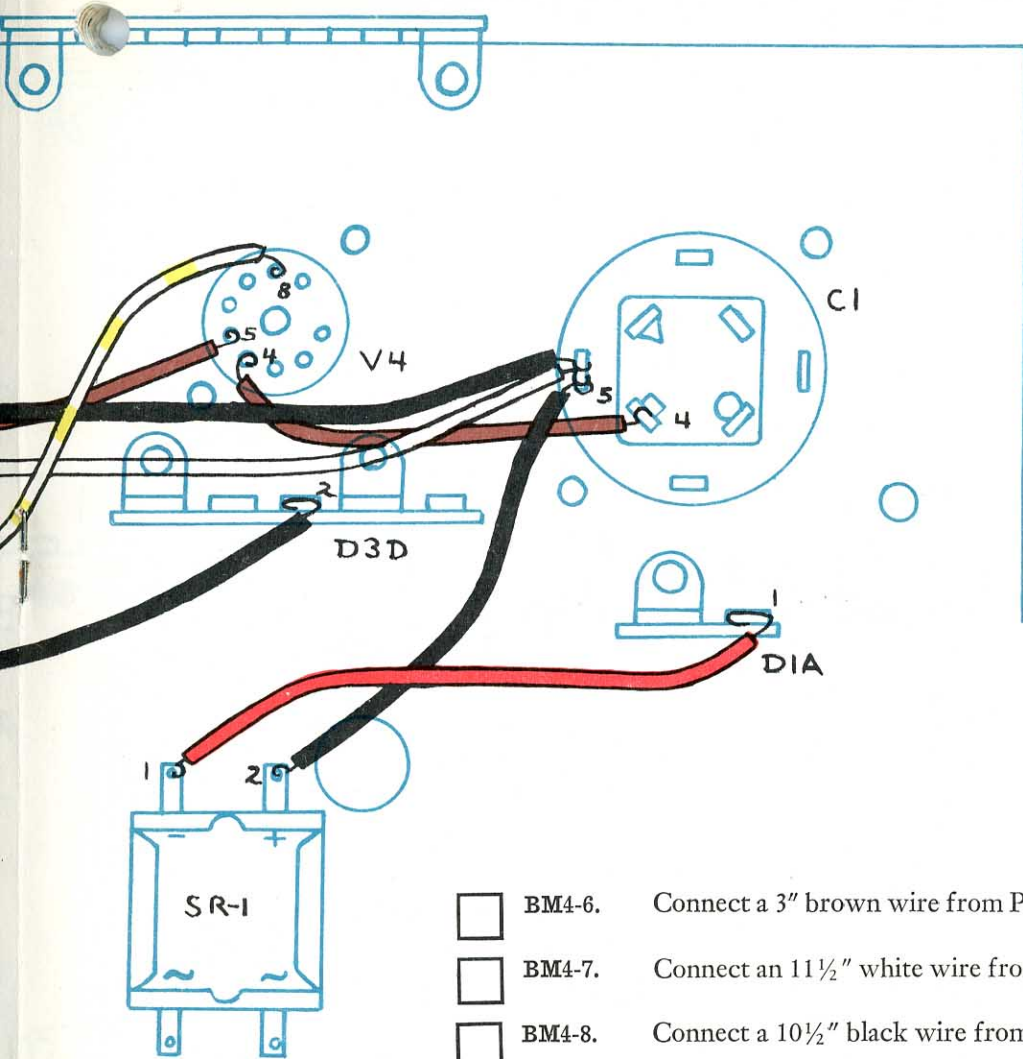

- BM4-6. Connect a 3" brown wire from Pin 4, V4 (S1) to Pin 4, C1.
- BM4-7. Connect an 11½" white wire from Pin 5, V1 (S1) to Pin 5, C1.
- BM4-8. Connect a 10½" black wire from L4 to Pin 5, C1.
- BM4-9. Connect a 3½" black wire from L4 to Pin 2, D3C.
- BM4-10. Connect a 5¼" yellow wire from Pin 8, V3 (S1) to Pin 5, C2.
- BM4-11. Connect a 7" yellow/white wire from Pin 8, V4 (S1) to Pin 1, C2.
- BM4-12. Connect a 3½" black wire from Pin 5, C1 (S3) to Pin 2, SR1 (S1).
- BM4-13. Connect a 4½" red wire from Pin 1, D1A to Pin 1, SR1 (S1).
- BM4-14. Connect a 3½" black wire from Pin 2, D3D to Pin 1, D2F.
- BM4-15. Connect a 4¼" black wire from Pin 1, D2F to Pin 3, V10.
- BM4-16. Connect a 3¾" red wire from Pin 1, D3C to Pin 4, C2.
- BM4-17. Connect a 6" red wire from Pin 1, D2C to Pin 1, D2E.
- BM4-18. Connect a 5¾" red/white wire from Pin 2, D2C to Pin 2, D2E.
- BM4-19. Connect a 3½" orange wire from Pin 9, V7 (S1) to Pin 9, V8.
- BM4-20. Connect a 3½" orange wire from Pin 9, V8 (S2) to Pin 9, V9.
- BM4-21. Connect a 3½" orange wire from Pin 9, V9 (S2) to Pin 9, V10.

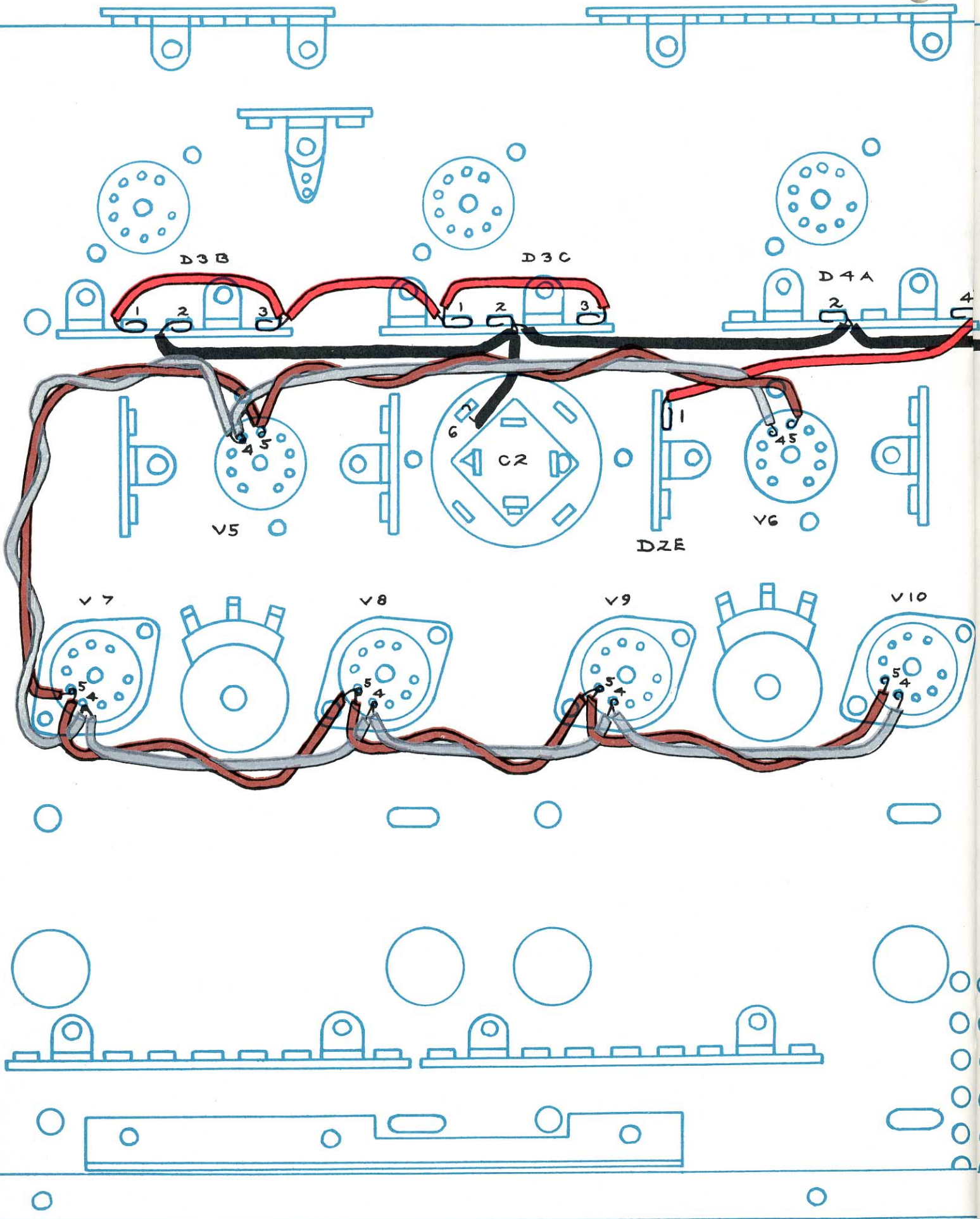

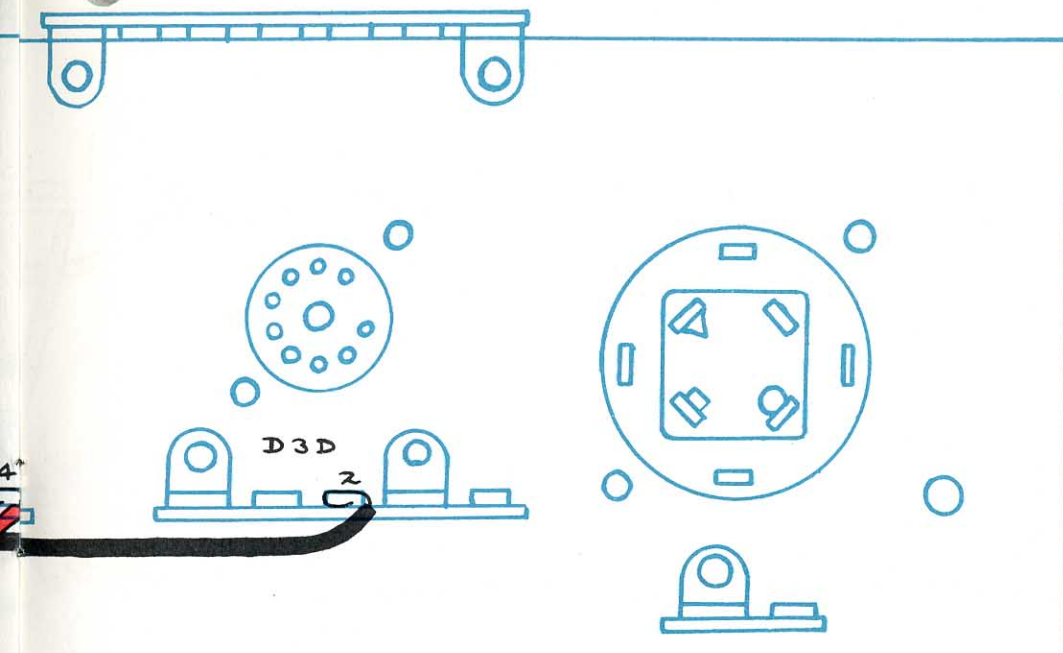

## Assembly Group BM-5

- BM5-1. Connect a 2½" red wire from Pin 1, D3B to Pin 3, D3B.
- BM5-2. Connect a 2¾" red wire from Pin 3, D3B to Pin 1, D3C.
- BM5-3. Connect a 2½" red wire from Pin 1, D3C to Pin 3, D3C.
- BM5-4. Connect a 4½" black wire from Pin 2, D3B to Pin 2, D3C.
- BM5-5. Connect a 1¾" black wire from Pin 2, D3C to Pin 6, C2.
- BM5-6. Connect a 4½" black wire from Pin 2, D3C to Pin 2, D4A.
- BM5-7. Connect a 4½" black wire from Pin 2, D4A to Pin 2, D3D.
- BM5-8. Connect a 4" red wire from Pin 1, D2E to Pin 4, D4A.
- BM5-9. Connect a 5½" grey wire to Pin 4, V5 and a 5½" brown wire to Pin 5, V5. Twist together and connect the grey wire to Pin 4, V6 (S1) and the brown to Pin 5, V6 (S1).
- BM5-10. Connect a 5½" grey wire to Pin 4, V7. Connect a 5" brown wire to Pin 5, V7. Twist together and connect the grey wire to Pin 4, V5 (S2) and the brown to Pin 5, V5 (S2).
- BM5-11. Connect a 4" grey wire to Pin 4, V7 (S2) and a 4" brown wire to Pin 5, V7 (S2). Twist together and connect the grey wire to Pin 4, V8 and the brown to Pin 5, V8.
- BM5-12. Connect a 4" grey wire to Pin 4, V8 (S2) and a 4" brown wire to Pin 5, V8 (S2). Twist and connect the grey wire to Pin 4, V9 and the brown wire to Pin 5, V9.
- BM5-13. Connect a 4" grey wire to Pin 4, V9 (S2) and a 4" brown wire to Pin 5, V9 (S2). Twist together and connect the grey wire to Pin 4, V10 and the brown to Pin 5, V10.

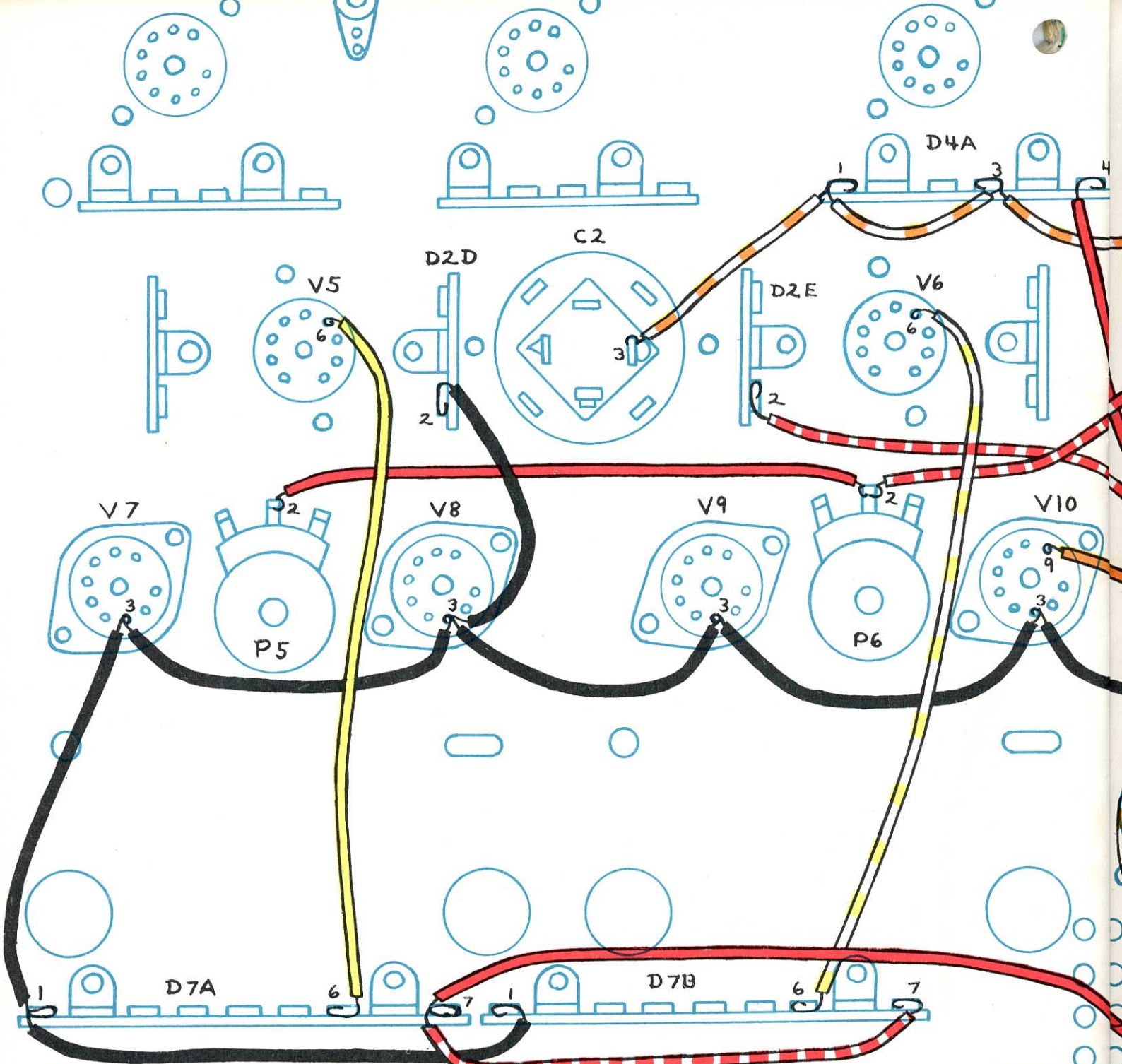

## Assembly Group BM-6

- BM6-1. Connect a 3¼" orange/white wire from Pin 3, C2 to Pin 1, D4A.
- BM6-2. Connect a 2½" orange/white wire from Pin 1, D4A to Pin 3, D4A.
- BM6-3. Connect a 3¼" orange/white wire from Pin 3, D4A to Pin 1, D3D.
- BM6-4. Connect a 2½" orange/white wire from Pin 1, D3D to Pin 3, D3D.
- BM6-5. Connect an 11¼" red/white wire from Pin 2, D2E to Pin 3, C3.
- BM6-6. Connect a 10¼" red wire from Pin 4, D4A to Pin 2, C3.

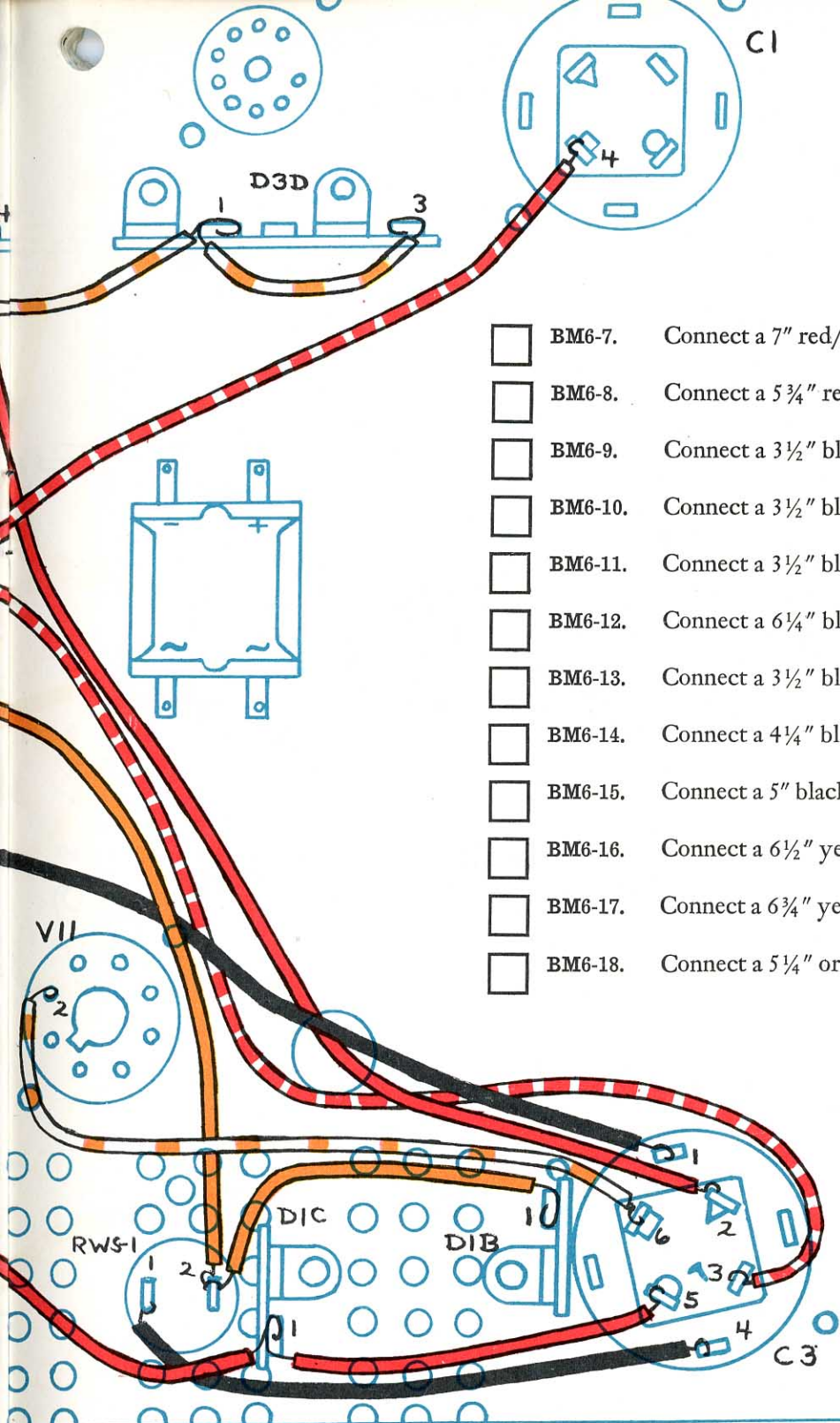

- BM6-7. Connect a 7" red/white wire from Pin 4, C1 to Pin 2, P6.
- BM6-8. Connect a 5 3/4" red wire from Pin 2, P5 (S1) to Pin 2, P6 (S2).
- BM6-9. Connect a 3 1/2" black wire from Pin 3, V7 to Pin 3, V8.
- BM6-10. Connect a 3 1/2" black wire from Pin 3, V8 to Pin 3, V9.
- BM6-11. Connect a 3 1/2" black wire from Pin 3, V9 to Pin 3, V10.
- BM6-12. Connect a 6 1/4" black wire from Pin 3, V10 to Pin 1, C3.
- BM6-13. Connect a 3 1/2" black wire from Pin 2, D2D to Pin 3, V8.
- BM6-14. Connect a 4 1/4" black wire from Pin 3, V7 to Pin 1, D7A.
- BM6-15. Connect a 5" black wire from Pin 1, D7A to Pin 1, D7B.
- BM6-16. Connect a 6 1/2" yellow wire from Pin 6, V5 to Pin 6, D7A.
- BM6-17. Connect a 6 3/4" yellow/white wire from Pin 6, V6 to Pin 6, D7B.
- BM6-18. Connect a 5 1/4" orange wire from Pin 9, V10 (S2) to Pin 2, RWS1.

- BM6-19. Connect a 3 3/4" orange wire from Pin 2, RWS1 (S2) to Pin 1, D1B.
- BM6-20. Connect a 5 1/4" orange/white wire from Pin 2, V11 to Pin 6, C3 (S1).
- BM6-21. Connect a 4 1/4" black wire from Pin 1, RWS1 (S1) to Pin 4, C3 (S1).
- BM6-22. Connect a 3 3/4" red wire from Pin 1, D1C to Pin 5, C3 (S1).
- BM6-23. Connect an 8 1/4" red wire from Pin 7, D7A to Pin 1, D1C.
- BM6-24. Connect a 5" red/white wire from Pin 7, D7A to Pin 7, D7B.

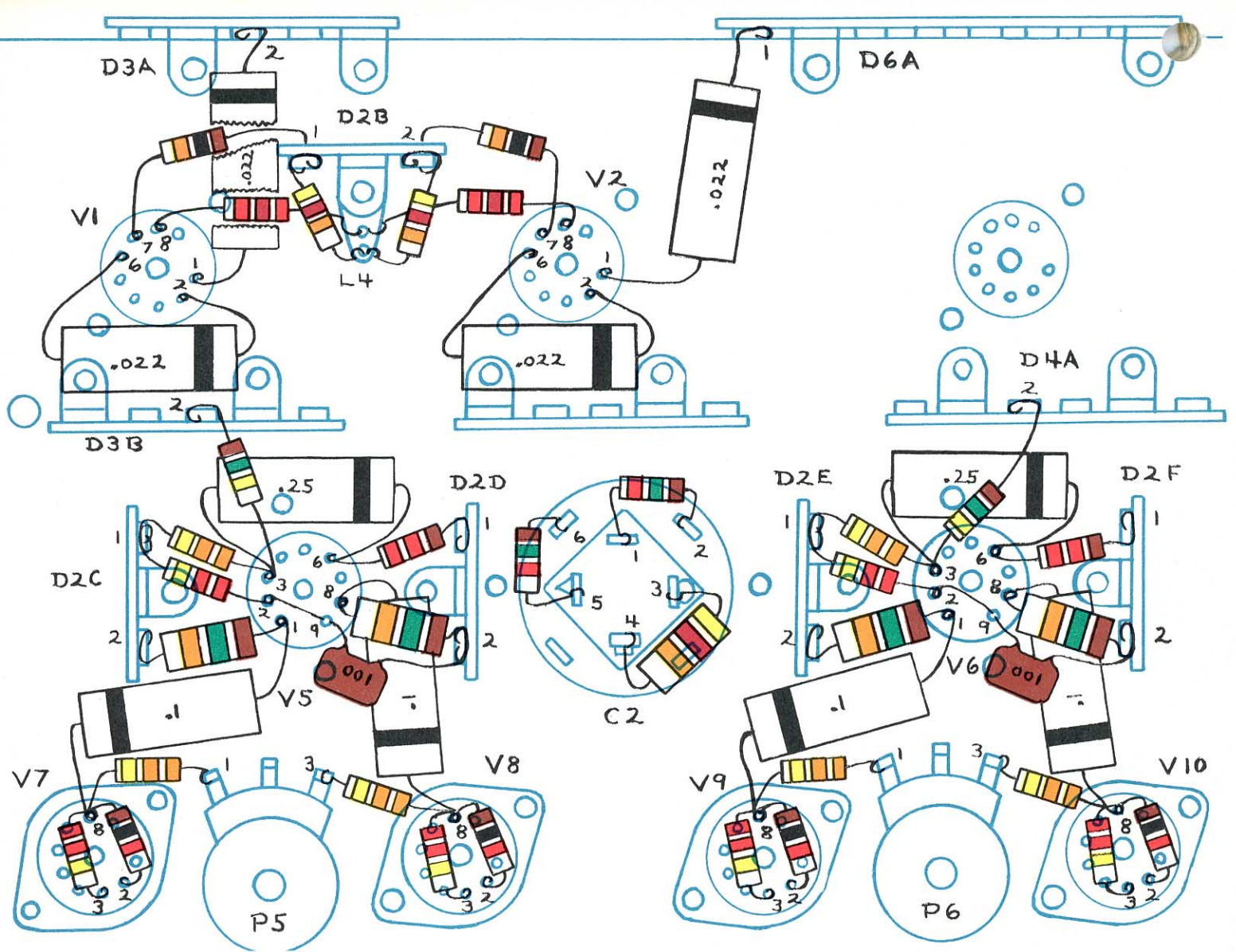

## Assembly Group BM-7

You will be working with resistors and capacitors now. These must all be trimmed to proper length before being used. Leave about 1/4" extra on each end for making mechanical joints. It is advisable to keep the leads as short as possible and the mechanical joints as small as possible to avoid short circuits with other wires, terminal pins, or the chassis itself. Whenever a wire is soldered, carefully inspect it to make sure it is not causing a short circuit.

- BM7-1.** Connect one end of a 10K resistor (brown, black, orange) to Pin 7, V1 (S1). Wire the other end through the hole in the bottom of Pin 1, D2B and connect to the top part of the pin.
- BM7-2.** Connect one end of a 10K resistor (brown, black, orange) to Pin 7, V2 (S1). Wire the other end through the hole in the bottom of Pin 2, D2B and connect to the top part of the pin.
- BM7-3.** Connect a 2.7K resistor (red, purple, red) from Pin 8, V1 to L4.
- BM7-4.** Connect a 2.7K resistor (red, purple, red) from L4 to Pin 8, V2.
- BM7-5.** Connect a 47K resistor (yellow, purple, orange) from L4 to Pin 1, D2B (S3).
- BM7-6.** Connect a 47K resistor (yellow, purple, orange) from L4 (S6) to Pin 2, D2B (S3).

- BM7-7.** Connect the black band end of a CPM .022 to Pin 2, D3A (S2). Connect the other end to Pin 1, V1.
- BM7-8.** Connect the black band end of a CPM .022 to Pin 1, D6A (S2). Connect the other end to Pin 1, V2.
- BM7-9.** Connect the black band end of a CPM .022 to Pin 2, V1. Connect the other end to Pin 6, V1.
- BM7-10.** Connect the black band end of a CPM .022 to Pin 2, V2. Connect the other end to Pin 6, V2.

## Assembly Group BM-8

In the next two groups you will be working in very close quarters. It is essential that you make sure all bare wires and joints are not causing short circuits. Check every soldered connection for this possibility. When soldering any connection, make sure all wires going to that pin are fully soldered.

- BM8-1.** Connect the black band end of a CPM .25 to Pin 6, V5. Connect the other end to Pin 3, V5.
- BM8-2.** Connect a 1.2K resistor (brown, red, red) from Pin 6, V5 (S3) to Pin 1, D2D (S2).

- BM8-3.** Connect the black band end of a CPM .1 to Pin 8, V7. Connect the other end to Pin 1, V5.
- BM8-4.** Connect the black band end of a CPM .1 to Pin 8, V8. Connect the other end to Pin 8, V5.
- BM8-5.** Connect a 330K resistor (orange, orange, yellow) from Pin 1, D2C to Pin 3, V5.
- BM8-6.** Connect a 220K resistor (red, red, yellow) from Pin 1, D2C (S3) to Pin 2, V5.
- BM8-7.** Connect a large 15K resistor (brown, green, orange) from Pin 2, D2C (S2) to Pin 1, V5 (S2).
- BM8-8.** Connect a large 15K resistor (brown, green, orange) from Pin 8, V5 (S2) to Pin 2, D2D.
- BM8-9.** Connect one end of a CM 100 to Pin 2, D2D (S4). Run the other end through Pin 9, V5 (S2) to Pin 2, V5 (S2).
- BM8-10.** Connect a 1.5K resistor (brown, green, red) from Pin 6, C2 (S2) to Pin 5, C2 (S2).
- BM8-11.** Connect a 1.5K resistor (brown, green, red) from Pin 1, C2 (S2) to Pin 2, C2 (S1).

## Assembly Group BM-9

- BM9-1.** Connect the black band end of a CPM .25 to Pin 6, V6. Connect the other end to Pin 3, V6.
- BM9-2.** Connect a 1.2K resistor (brown, red, red) from Pin 6, V6 (S3) to Pin 1, D2F (S4).
- BM9-3.** Connect the black band end of a CPM .1 to Pin 8, V10. Connect the other end to Pin 8, V6.
- BM9-4.** Connect the black band end of a CPM .1 to Pin 8, V9. Connect the other end to Pin 1, V6.
- BM9-5.** Connect a 330K resistor (orange, orange, yellow) from Pin 1, D2E to Pin 3, V6.
- BM9-6.** Connect a 220K resistor (red, red, yellow) from Pin 1, D2E (S4) to Pin 2, V6.
- BM9-7.** Connect a large 15K resistor (brown, green, orange) from Pin 2, D2E (S3) to Pin 1, V6 (S2).
- BM9-8.** Connect a large 15K resistor (brown, green, orange) from Pin 8, V6 (S2) to Pin 2, D2F.
- BM9-9.** Connect one end of a CM 100 to Pin 2, D2F (S3). Run the other end through Pin 9, V6 (S2) to Pin 2, V6 (S2).
- BM9-10.** Connect a large 47K resistor (yellow, purple, orange) from Pin 4, C2 (S2) to Pin 3, C2 (S2).

## Assembly Group BM-10

Frequently so many leads will be connected to a single pin, that it will be difficult to place each lead directly on the pin. In such cases it will be satisfactory to have the last lead or two positioned tightly over the leads that were put on previously. Make sure when you solder these pins that all the wires and leads are soldered firmly. Watch out for short circuits.

- BM10-1.** Connect a 150K resistor (brown, green, yellow) from Pin 3, V5 (S3) to Pin 2, D3B.
- BM10-2.** Connect a 150K resistor (brown, green, yellow) from Pin 3, V6 (S3) to Pin 2, D4A.
- BM10-3.** Connect a 330K resistor (orange, orange, yellow) from Pin 8, V7 to Pin 1, P5 (S1).
- BM10-4.** Connect a 330K resistor (orange, orange, yellow) from Pin 3, P5 (S1) to Pin 8, V8.
- BM10-5.** Connect a 1K resistor (brown, black, red) from Pin 8, V7 to Pin 2, V7 (S1).
- BM10-6.** Connect a 220K resistor (red, red, yellow) from Pin 8, V7 (S4) to Pin 3, V7 (S3).
- BM10-7.** Connect a 1K resistor (brown, black, red) from Pin 8, V8 to Pin 2, V8 (S1).
- BM10-8.** Connect a 220K resistor (red, red, yellow) from Pin 8, V8 (S4) to Pin 3, V8 (S4).
- BM10-9.** Connect a 330K resistor (orange, orange, yellow) from Pin 8, V9 to Pin 1, P6 (S1).
- BM10-10.** Connect a 330K resistor (orange, orange, yellow) from Pin 3, P6 (S1) to Pin 8, V10.
- BM10-11.** Connect a 1K resistor (brown, black, red) from Pin 8, V9 to Pin 2, V9 (S1).
- BM10-12.** Connect a 220K resistor (red, red, yellow) from Pin 8, V9 (S4) to Pin 3, V9 (S3).
- BM10-13.** Connect a 1K resistor (brown, black, red) from Pin 8, V10 to Pin 2, V10 (S1).
- BM10-14.** Connect a 220K resistor (red, red, yellow) from Pin 8, V10 (S4) to Pin 3, V10 (S4).

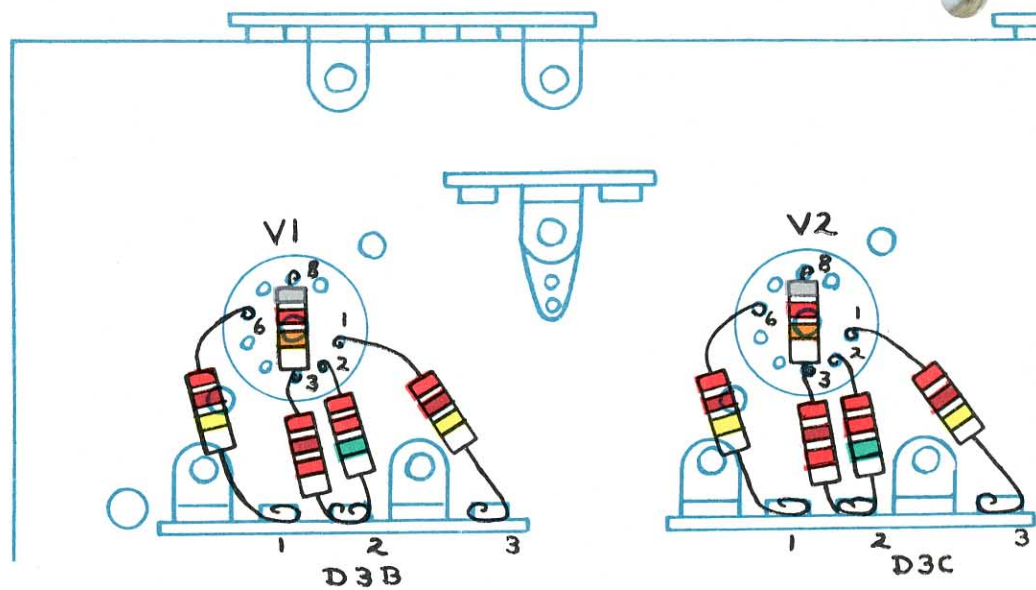

## Assembly Group BM-11

- BM11-1. Connect an 82K resistor (grey, red, orange) from Pin 8, V1 (S3) to Pin 3, V1.
- BM11-2. Connect an 82K resistor (grey, red, orange) from Pin 8, V2 (S3) to Pin 3, V2.
- BM11-3. Connect a 270K resistor (red, purple, yellow) from Pin 6, V1 (S2) to Pin 1, D3B (S2).
- BM11-4. Connect a 2.7K resistor (red, purple, red) from Pin 3, V1 (S2) to Pin 2, D3B.
- BM11-5. Connect a 2.2M resistor (red, red, green) from Pin 2, V1 (S3) to Pin 2, D3B (S4).
- BM11-6. Connect a 270K resistor (red, purple, yellow) from Pin 1, V1 (S2) to Pin 3, D3B (S3).
- BM11-7. Connect a 270K resistor (red, purple, yellow) from Pin 6, V2 (S2) to Pin 1, D3C (S4).
- BM11-8. Connect a 2.7K resistor (red, purple, red) from Pin 3, V2 (S2) to Pin 2, D3C.
- BM11-9. Connect a 2.2M resistor (red, red, green) from Pin 2, V2 (S3) to Pin 2, D3C (S6).
- BM11-10. Connect a 270K resistor (red, purple, yellow) from Pin 1, V2 (S2) to Pin 3, D3C (S2).

## Assembly Group BM-12

- BM12-1. Connect the black band end of a CPM .1 to Pin 2, D6A (S3). Connect the other end to Pin 6, V3.
- BM12-2. Connect a CM 560 from Pin 3, D6A (S4) to Pin 7, V3.
- BM12-3. Connect a 1M resistor (brown, black, green) from Pin 4, D6A (S2) to Pin 2, V3.
- BM12-4. Connect a CM 47 from Pin 5, D6A (S3) to Pin 2, V3 (S2).
- BM12-5. Connect the black band end of a CPM .1 to Pin 6, D6A (S3). Connect the other end to Pin 1, V3.

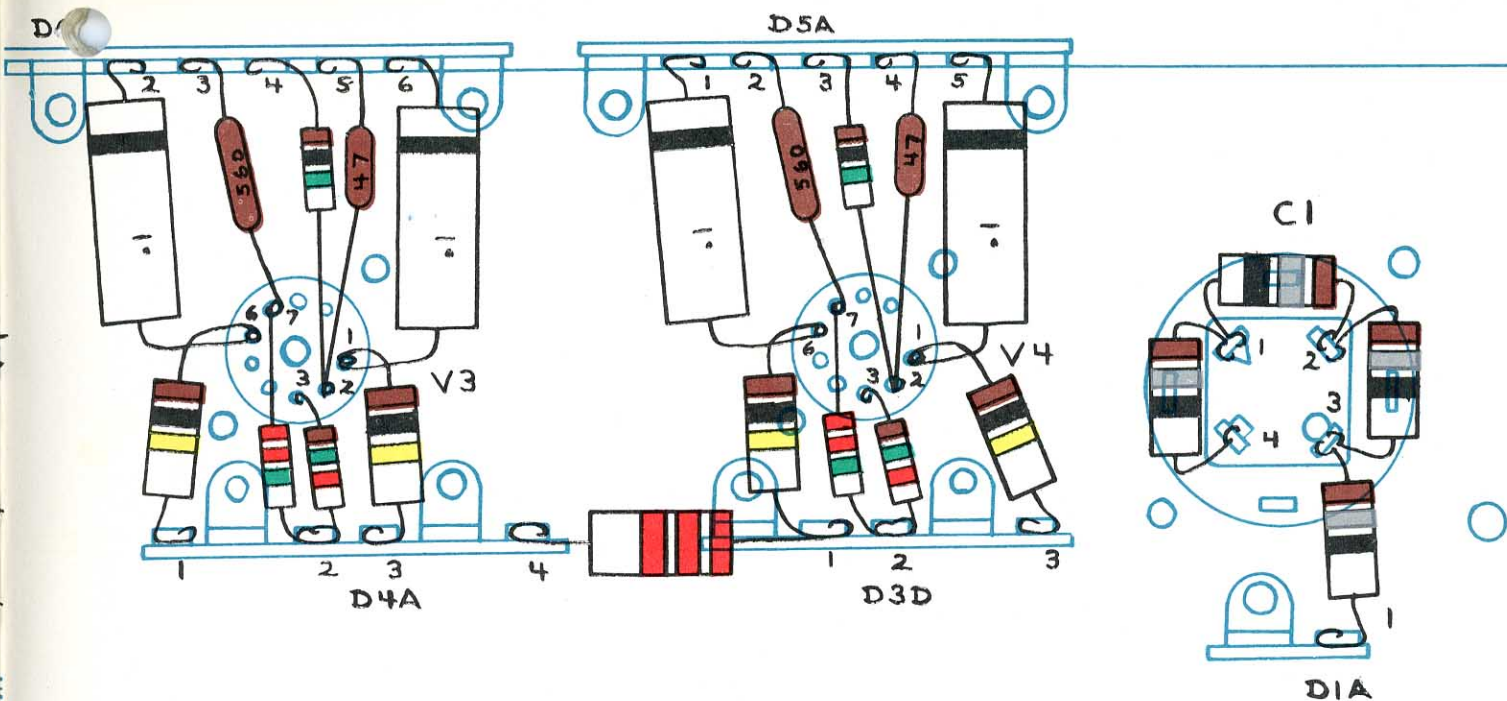

- BM12-6. Connect a large 100K resistor (brown, black, yellow) from Pin 6, V3 (S2) to Pin 1, D4A (S3).
- BM12-7. Connect a 2.2M resistor (red, red, green) from Pin 7, V3 (S2) to Pin 2, D4A.
- BM12-8. Connect a 1.5K resistor (brown, green, red) from Pin 3, V3 (S1) to Pin 2, D4A (S5).
- BM12-9. Connect a large 100K resistor (brown, black, yellow) from Pin 1, V3 (S2) to Pin 3, D4A (S3).
- BM12-10. Connect the black band end of a CPM .1 to Pin 1, D5A (S3). Connect the other end to Pin 6, V4.
- BM12-11. Connect a CM 560 from Pin 2, D5A (S4) to Pin 7, V4.

## Assembly Group BM-13

- BM13-1. Connect a 1M resistor from Pin 3, D5A (S2) to Pin 2, V4.
- BM13-2. Connect a CM 47 from Pin 4, D5A (S3) to Pin 2, V4 (S2).
- BM13-3. Connect the black band end of a CPM .1 to Pin 5, D5A (S3). Connect the other end to Pin 1, V4.
- BM13-4. Connect a large 100K resistor (brown, black, yellow) from Pin 6, V4 (S2) to Pin 1, D3D.
- BM13-5. Connect a 2.2M resistor (red, red, green) from Pin 7, V4 (S2) to Pin 2, D3D.
- BM13-6. Connect a 1.5K resistor (brown, green, red) from Pin 3, V4 (S1) to Pin 2, D3D (S5).
- BM13-7. Connect a large 100K resistor (brown, black, yellow) from Pin 1, V4 (S2) to Pin 3, D3D (S2).
- BM13-8. Connect a large 2.2K resistor (red, red, red) from Pin 4, D4A (S3) to Pin 1, D3D (S5).
- BM13-9. Connect a large 18 ohm resistor (brown, grey, black) from Pin 1, C1 to Pin 2, C1.
- BM13-10. Connect a large 18 ohm resistor (brown, grey, black) from Pin 2, C1 (S2) to Pin 3, C1.
- BM13-11. Connect a large 18 ohm resistor (brown, grey, black) from Pin 3, C1 (S2) to Pin 1, D1A (S2).
- BM13-12. Connect a large 18 ohm resistor (brown, grey, black) from Pin 1, C1 (S2) to Pin 4, C1 (S3).

# Mechanical Assembly A-3

You are now going to mount the three transformers to the top of the main chassis. Turn the chassis over so the top is up.

Assemble 4 spring clip fasteners to the feet of each output transformer (identified as TRA-8-5-1) as shown in Figure 14. Place one of these transformers on the chassis with the feet lining up over the chassis mounting holes. Feed the blue, red and brown wires through the grommet nearest the white stand-up resistor. The other wires will be fed through the second grommet. Hold the transformer down and slowly turn the chassis over. Pull up on all transformer wires to remove the slack. Be sure that there is a total of *seven* wires coming up through the two grommets. Fasten the transformer down with three of the longer sheet metal screws. See Figure 15. The fourth screw will be used to hold the special bracket in place.

Mount the other output transformer in the same way. Do not squeeze the two heavy cables on the top of the chassis. The blue, brown and red wires will be fed through the grommet nearest the first output transformer. Feed the other wires through the remaining grommet.

Mount the chassis bracket using the remaining long sheet metal screws. See Figure 15. Be sure that the bracket is positioned as shown.

Mount the power transformer as shown in Figure 16. Use the cupped washers and the machine nuts to hold in place. The transformer wires should be on the side away from the edge of the main.

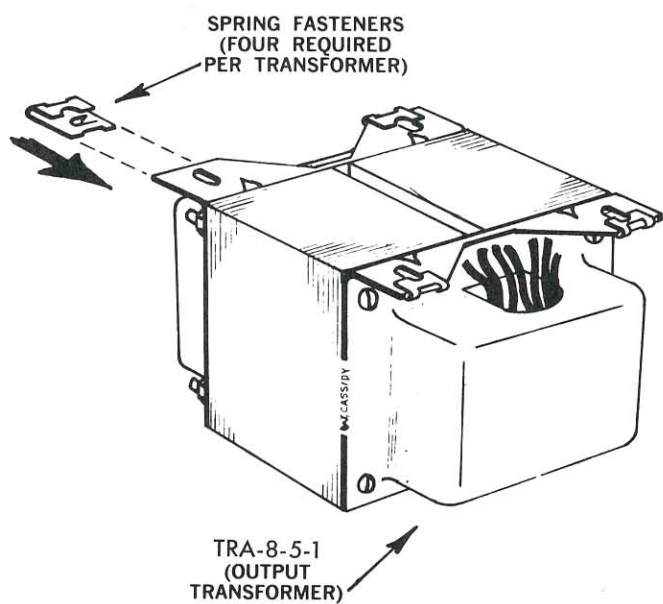

FIGURE 14

(TYPICAL MOUNTING OF FASTENERS FOR T2 & T3)

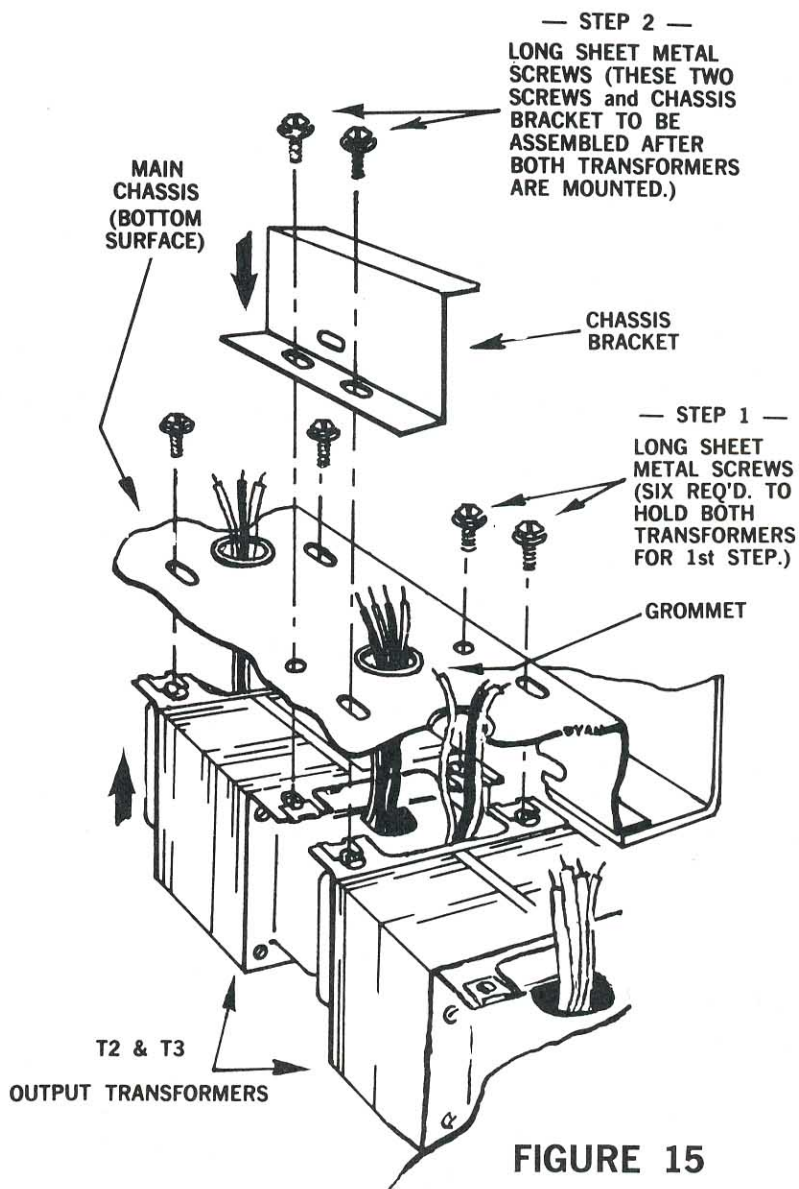

FIGURE 15

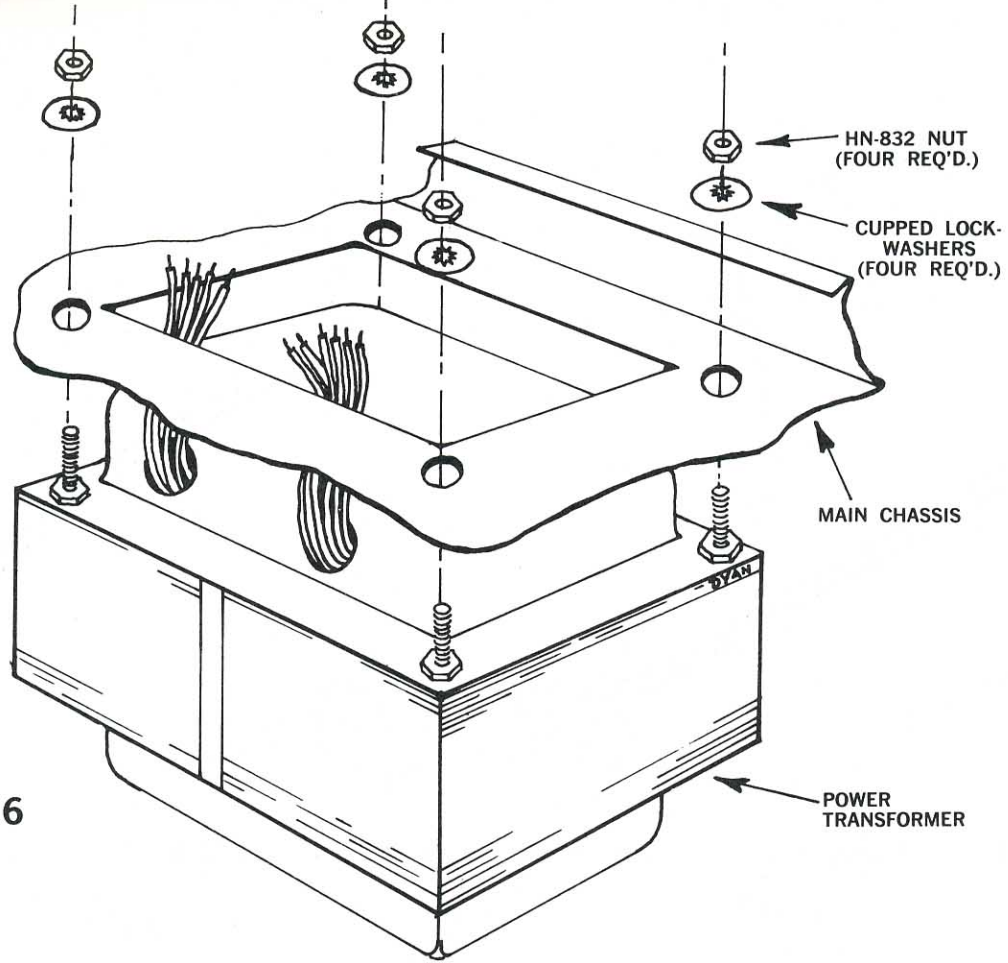

FIGURE 16

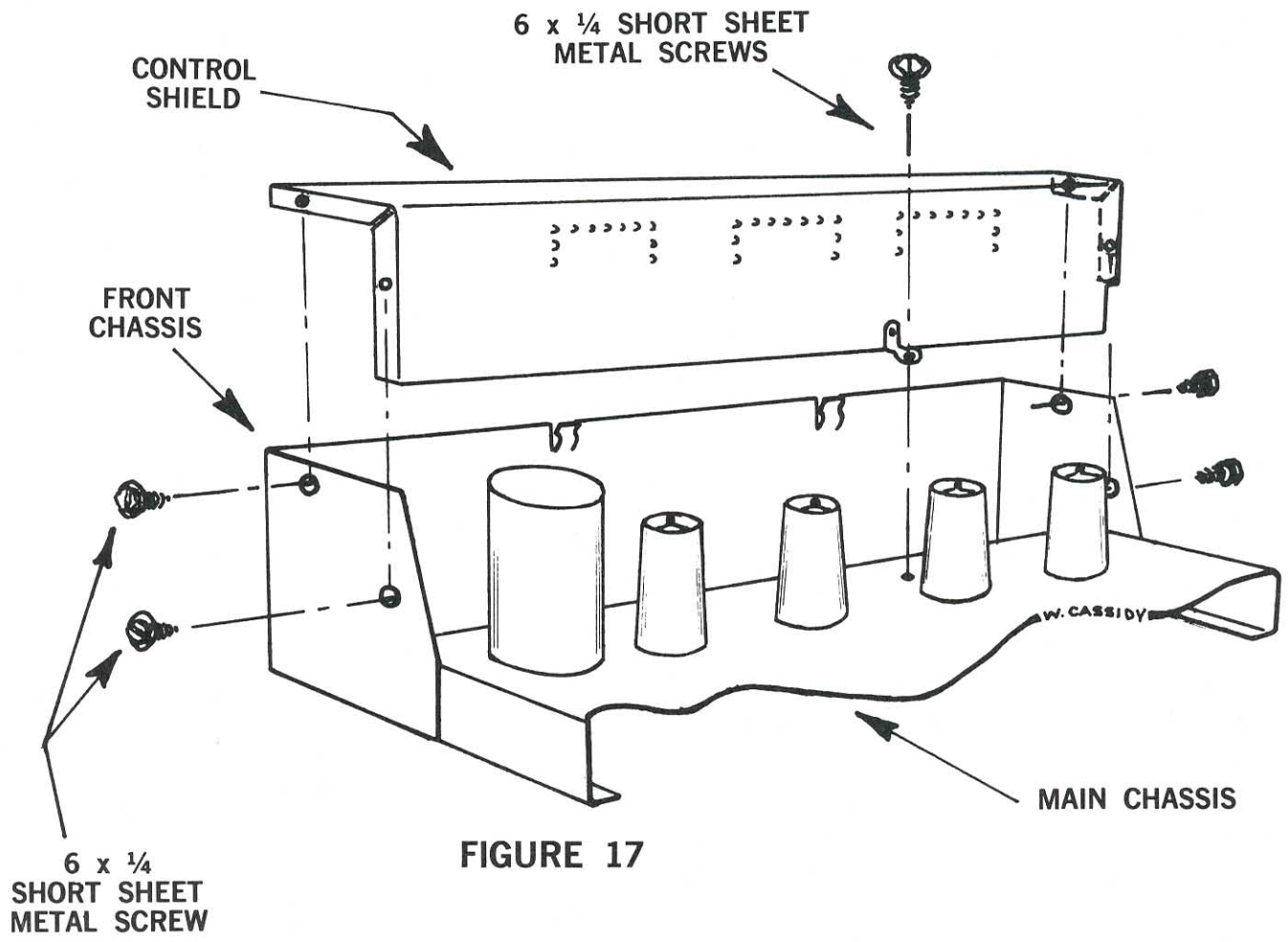
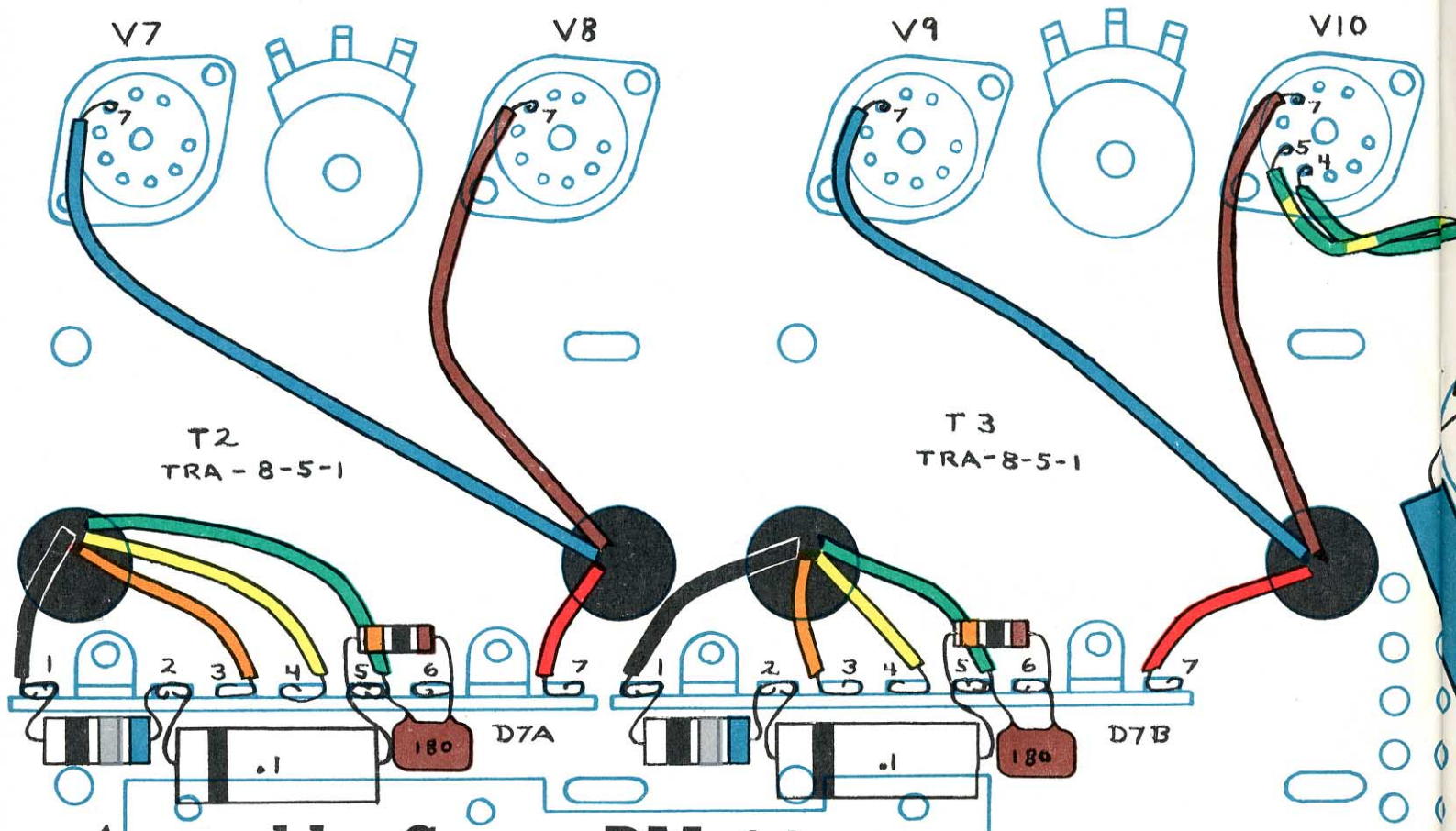

FIGURE 17



## Assembly Group BM-14

The following wires are from T1

- BM14-1. Connect the red/yellow wire to Pin 1, C3 (S2).
- BM14-2. Twist the two black wires together and connect one to Pin 2, AC-1 (S3) and the other to Pin 1, on the tip of the fuse post (S2).
- BM14-3. Twist the green and green/yellow wires together and connect the green to Pin 4, V10 (S2) and the green/yellow to Pin 5, V10 (S2).
- BM14-4. Twist the red and red/blue wires together and connect the red to Pin 4, V11 (S1) and the red/blue to Pin 6, V11 (S1).
- BM14-5. Connect one of the orange wires to Pin 3, SR-1 (S1) and the other to Pin 4, SR-1 (S1).
- BM14-6. Twist the two yellow wires together and connect one to Pin 2, V11, and the other one to Pin 8, V11 (S1).

The following wires are from T3

- BM14-7. Connect the blue wire to Pin 7, V9 (S1).
- BM14-8. Connect the brown wire to Pin 7, V10 (S1).
- BM14-9. Connect the red wire to Pin 7, D7B (S2).
- BM14-10. Connect the black wire to Pin 1, D7B.
- BM14-11. Connect the orange wire to Pin 3, D7B (S2)
- BM14-12. Connect the yellow wire to Pin 4, D7B (S2).
- BM14-13. Connect the green wire to Pin 5, D7B.

The following wires are from T2

- BM14-14. Connect the blue wire to Pin 7, V7 (S1).
- BM14-15. Connect the brown wire to Pin 7, V8 (S1).

# Assembly Group BM-15

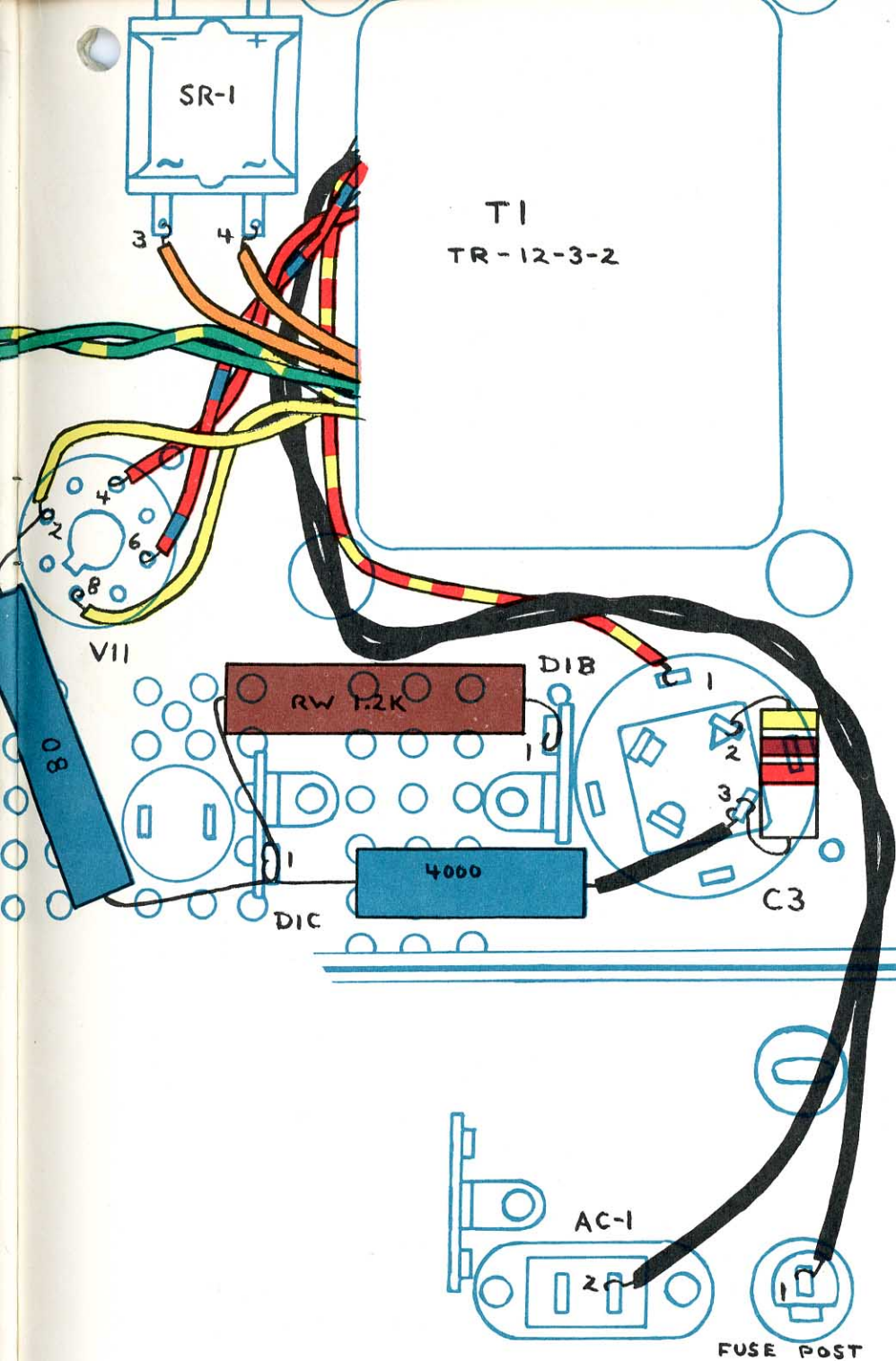

**BM15-1.** Connect a large 68 ohm resistor (blue, grey, black) from Pin 1, D7A (S4) to Pin 2, D7A.

**BM15-2.** Connect the black band end of a CPM .1 to Pin 2, D7A (S2). Connect the other end to Pin 5, D7A.

**BM15-3.** Connect a 10K resistor (brown, black, orange) from Pin 5, D7A to Pin 6, D7A.

**BM15-4.** Connect a CM 180 from Pin 5, D7A (S5) to Pin 6, D7A (S3).

**BM15-5.** Connect a large 68 ohm resistor (blue, grey, black) from Pin 1, D7B (S4) to Pin 2, D7B.

**BM15-6.** Connect the black band end of a CPM .1 to Pin 2, D7B (S2). Connect the other end to Pin 5, D7B.

**BM15-7.** Connect a 10K resistor (brown, black, orange) from Pin 5, D7B to Pin 6, D7B.

**BM15-8.** Connect a CM 180 from Pin 5, D7B (S5) to Pin 6, D7B (S3).

The next three steps involve resistors that will get quite warm in actual operation. Make sure that they don't come into contact with any other wires or components. Even 1/8" space will be sufficient.

**BM15-9.** Connect an RW80 from Pin 2, V11 (S3) to Pin 1, D1C.

**BM15-10.** Connect an RW1200 from Pin 1, D1C to Pin 1, D1B (S2).

**BM15-11.** Add a 1/4" piece of black insulation to one end of an RW4000 and connect to Pin 3, C3. Connect the other end to Pin 1, D1C (S5).

**BM15-12.** Connect a large 4.7K resistor (yellow, purple, red) from Pin 2, C3 (S2) to Pin 3, C3 (S3).

**BM14-16.** Connect the red wire to Pin 7, D7A (S3).

**BM14-17.** Connect the black wire to Pin 1, D7A.

**BM14-18.** Connect the orange wire to Pin 3, D7A (S2).

**BM14-19.** Connect the yellow wire to Pin 4, D7A (S2).

**BM14-20.** Connect the green wire to Pin 5, D7A.

# Very Important!

## the Double Check System

The electrical assembly is now complete. It is time to pause for a moment and make sure that there are no errors, and that every joint has been soldered properly. It is quite understandable that at this stage of the assembly there will be a tremendous incentive to forge ahead quickly to finish the job. Unfortunately this attitude can cause you to overlook a small error that will lead to serious and expensive damage to your amplifier.

In extensive evaluation tests we had LK-48 kits built by a wide variety of people. Over 90% of the kits worked perfectly upon completion. Of this percentage, virtually everyone had taken the trouble to follow this double checking procedure, and most of them reported catching small errors. In those units that did not work we discovered that malfunction could, in every case, be traced directly to skipping of the double-check. Simple miswiring errors or short circuits prevented proper operation of the amplifier. Stop for a moment, RELAX, and be sure to check over your work.

An easy method of doing this has been provided. Call in a friend or another member of the family. Have them look over charts AF1, AR1, and AM1. On these diagrams of the underside of the chassis, a series of numbers have been placed next to each pin or terminal. These numbers indicate the number of wires and leads (including those from resistors or capacitors) that have been soldered to that pin. If circled and uncircled numbers are given, use the circled numbers as all connections have now been made. While you count off the number of leads on each pin and terminal, your assistant can check your count against the chart. When you count the leads going to pin 1 of V3, your helper will observe that this agrees with his chart and place a small check mark on it. This will be continued until the entire amplifier is checked over. It will seldom take more than 20 minutes for this complete check.

While you are counting the wires, you can also be checking for short circuits and proper soldering. It would be very handy if you had a tool with a small sharp point (like an ice pick) to probe the connections and make certain they are soldered properly. A pencil with a sharp point can also be used. Even the most meticulous worker can make a mistake or have a poorly

soldered joint. LOOK SHARP! Move every lead and wire a little bit to insure it is not accidentally causing a short circuit with some other wire or pin.

If a mistake is caught and it involves a component which is now too short to reach the correct pin, refer to Fig. 3 on splicing a piece of buss wire. This will work quite well and eliminate the need for purchasing a replacement.

## Final Assembly

Turn the chassis over and shake it violently. This is to get all the little pieces of wire out of the unit. Make certain that there are no pieces caught in any crevices or in the tube sockets or condenser can bases. This could cause short circuits.

## Assembly Group A-4

A4-1.

Mount the tubes, using the lettering on the chassis as a guide. At this point you should check out the amplifier. Refer to the front panel which shows the location of controls and switches. Locate the Loudness control which is in the lower right hand corner of the front. Make sure this control is pushed in (power off position). Turn the amplifier on its side so you can readily see both the underside and top of the chassis. Insert the line cord into an AC outlet (do not use with DC) and pull the Loudness control towards you, until the amplifier clicks on. Watch both the underside and top side for any signs of overheating, sparks, smoke, or glowing tubes. At the first sign, turn the unit off and refer to section entitled, "In Case of Difficulty." If all seems right, turn the unit off, remove line cord from AC outlet, and continue.

A4-2.

Place a tube shield over tubes V1, V2, V3 and V4. Press down hard with a counter-clockwise motion to get the shield on.

A4-3.

Assemble the control shield with five 6 x 1/4" short sheet metal screws (see fig. 17 on page 35).

A4-4.

Assemble the bottom cover with the #6 sheet metal screws as in fig. 18. Be careful that this bottom cover does not touch bare wires inside.

A4-5.

Mount the front panel and knobs as shown in fig. 19. Put the panel in place and thread on the nuts to hold the panel down. Be careful not to scratch the panel. Then put on the knobs

with the small screwdriver supplied.

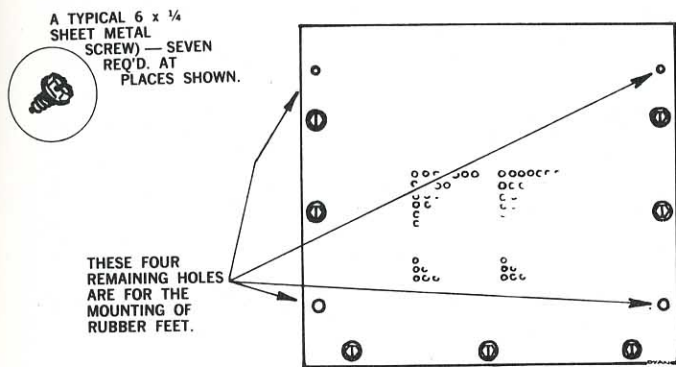

FIGURE 18

## Setting the DC Balance Controls (P5 and TP6)

To set the DC balance controls for minimum distortion, the following items will be needed: the special audio cable and the small screwdriver supplied, plus one loudspeaker.

Take the audio cable, which has a jack on one end and two bare wires on the other, and connect the bare leads to the Channel A speaker terminals. Connect one lead to "0" and one to 4. Insert the jack in the Channel B tuner input. Connect a loudspeaker to the Channel B speaker terminals. Remove V5 (a 7199 tube). Set controls as follows:

- Input Selector .....tuner
- Stereo Selector .....stereo
- Bass and treble controls .....0

- Stereo Balance .....0
- Loudness-Volume switch .....L
- Tape Monitor .....Out
- Scratch filter .....Out
- Equalization .....Either position
- Loudness control .....0

Insert line cord into an AC outlet and turn unit on by pulling the Loudness Control towards you. Wait a few minutes for the amplifier to completely warm up. Slowly turn Loudness Control clockwise until you can just hear a low hum in the loudspeaker. (If you turn volume up too high the amplifier will go into oscillation due to the missing V5, and you will hear a motor-boating noise in the loudspeaker.) Take the small screwdriver and adjust P5 (on top of chassis) for minimum hum (hum is a 60 cycle low frequency noise — do not confuse it with any high frequency noises present).

Turn off amplifier and replace V5 tube. Connect audio cable to Channel B speaker terminals and insert jack in Channel A tuner input. Connect the loudspeaker to Channel A speaker terminals. Remove V6, the other 7199 tube. Keep front panel controls the same. Turn on unit. Adjust P6 for minimum hum. Turn off amplifier and remove line cord. Replace V6. The unit is now adjusted for minimum distortion. Further adjustment will not be needed unless output tubes are replaced, or after a year of use.

## Congratulations!

Now . . . sign your personal label "This kit was built by —" . . . connect your amplifier into the rest of your system (see next few pages) . . . relax . . . with one of the finest amplifiers ever made.

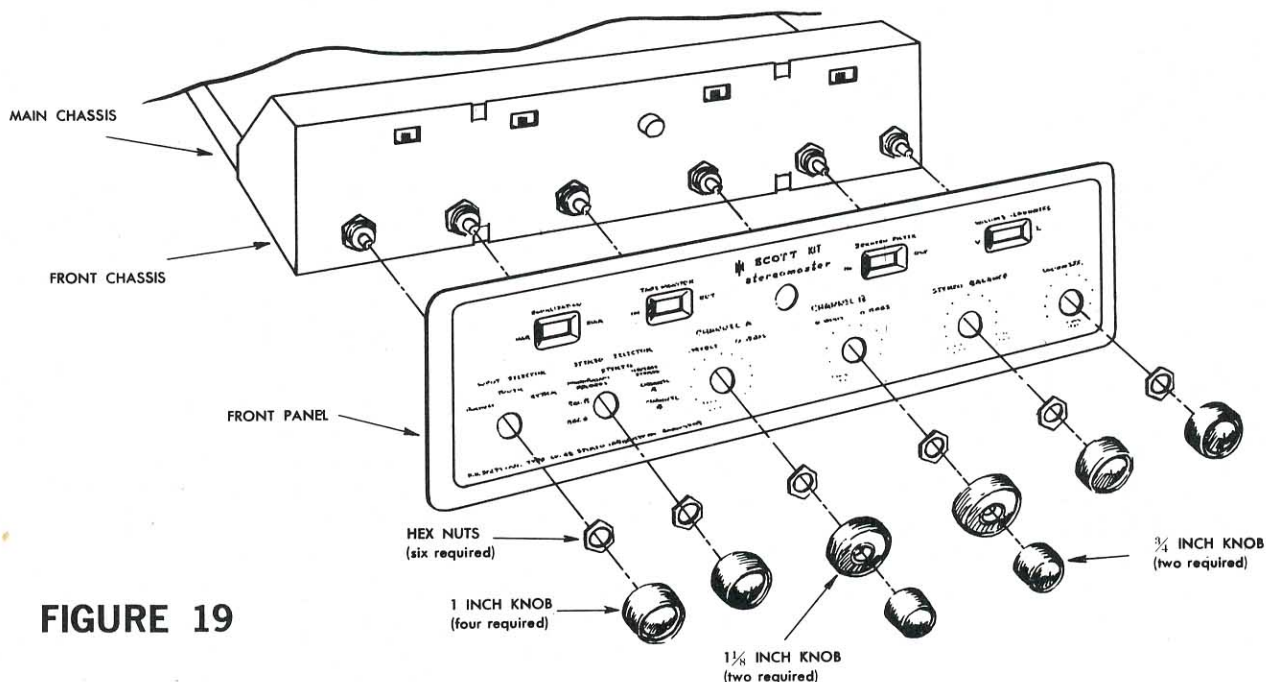

FIGURE 19

## INSTALLATION

The LK-48 can be placed on a table or bookshelf, in existing furniture like an end table, buffet, or room divider, or in a specially designed equipment cabinet. A handsome hand rubbed wood accessory case is available from your dealer in finishes to blend with your decor.

Wherever the LK-48 is placed, adequate provision should be made for ventilation. If this is not done, the life of the internal components will be appreciably shortened. By adequate ventilation we mean some space above and behind the unit where air may circulate freely, or, if it is installed in a cabinet, an open back. Remember that this model draws about 200 watts of electricity, and if you placed a 200 watt bulb in a cabinet, you would need a fair amount of moving air to keep it from getting too warm.

## CONNECTIONS

(A diagram showing all these connections appears at the end of this section)

### Power

The power cord should be plugged into any 105 to 125 volt, 50 to 60 cycle AC source. DO NOT attempt to use with DC.

### Speakers

Terminal strips for making speaker connections are located on the back. . . . The one marked Channel A Speaker is for connecting the left speaker (as you face them). The one marked Channel B Speaker is for the right. Below each strip are the numbers, 4, 8, 16, 0 and 0. This permits you to match the amplifier output to the impedance of the speaker. Each speaker is rated by its manufacturer at a certain impedance. This information is either marked on the speaker or can be supplied by the dealer.

To make the connections use standard twin lead lamp wire. Simply connect one end of the twin lead wire to the two terminals on the speaker or speaker enclosure, as the case may be. At the other end connect one lead to either "0" terminal and the other lead to the terminal whose number is closest to the value of the loudspeaker impedance. When making the connections, be extremely careful to prevent any strands of wire from one screw accidentally touching the other screw, as the speaker will not perform properly.

After the speakers are connected, they should be properly phased to give a good stereo effect with full bass. Phasing instructions are to be found later in this manual.

### How to Connect Your Record Player

(with magnetic cartridge)

The shielded leads from your stereo changer or turntable should be connected to the inputs marked Mag High on the back of the LK-48. The lead carrying the left channel information should be inserted in the top (Channel A) jack; the lead carrying the right channel information should be inserted in the bottom (Channel B) jack.

Virtually all magnetic stereo cartridges now on the market will have sufficient output to drive the LK-48 to its full 48 watts. If the cartridge used has an extremely low output so that even with the volume control all the way up there is insufficient volume from the speakers, then insert the phono leads in Mag Low. This will supply additional gain, but should only be done if absolutely necessary. Use *either* the Mag Low or Mag High inputs, do not use both sets simultaneously.

If only a monophonic cartridge is being used, the single shielded lead should be inserted in Mag High Channel A input. The **Stereo Selector Switch** should then be set to *Channel A*.

If the cartridge used is not shielded against hum pickup, it is suggested that the two leads be twined around each other. Because of the extremely powerful transformers used in the LK-48, it would be advisable to keep the record player at least two feet away in this instance.

# Instructions for Using the Model LK-48 48 Watt Complete Stereophonic Amplifier

The LK-48 is extremely flexible and offers a wide variety of operating features, yet it is easy to use. Careful reading of these instructions will enable any member of the family to operate the LK-48.



## How to Connect Your Record Player

(with crystal or ceramic cartridge)

Magnetic cartridges produce low outputs. Crystal and ceramic cartridges produce stronger signals on the order of  $\frac{1}{4}$  to over 1 volt. With record players using these cartridges, the shielded leads should be inserted in the Extra inputs. The lead carrying the left channel information should go into the A or top input, while the lead carrying the right channel information should go into the B or bottom input. The **Input Selector** on the front panel should, of course, be set to *Extra* whenever you want to listen to the phonograph.

Otherwise, the information given in the previous section is applicable here, too.

## How to Connect Your Tape Recorder

For playback of pre-recorded tape on a regular tape recorder with stereo playback provisions, the shielded leads from the tape machine should be inserted in the Playback input jacks on the back of the LK-48. The lead containing the left channel information should be inserted into the Channel A or top jack, while the lead containing the right channel information goes to the Channel B or bottom jack. The **Tape Monitor Control** on the front panel should be in the *In* position. It now will make no difference where the **Input Selector** is set; the pre-recorded tape will be heard through the speakers regardless. *Remember, unless you are listening to tape, the **Tape Monitor Control** must be in the *Out* position.*

If the pre-recorded tape is to be played on a Tape Deck, a different system should be employed. A tape deck is a mechanism which consists simply of the tape transport and heads with no recording or playback amplifiers or preamplifiers whatsoever. Such a device produces a very small electrical signal similar to that obtained from a magnetic phonograph cartridge. Because of this, the connections are made to *Mag Low\** on the back panel.

The system is then considered identical to a standard phonograph and the same rules apply as outlined before, with one exception. The **Equalization Switch** on the front panel should be placed in the *NAB Tape* Position.

If monophonic tape is being played on a stereo tape recorder or tape deck, the connections described above still apply. The only change is that the **Stereo Selector** is set to either *Channel A* or *Channel B* as the case may be. If a monophonic tape deck or tape recorder is used there is only one shielded lead to connect, and this should go into the Channel A input.

To record directly from the LK-48, a special set of outputs is available on the back panel. These are the Tape Recorder jacks. Connect a shielded wire from the Channel A or top jack to the Radio or high level input of the tape recorder. The tape recorder will automatically record directly from the LK-48 whatever is playing over Channel A of the system (be it FM, phonograph, etc.) completely unaffected by the loudness and tone controls. If the lead is connected from the Channel B or bottom jack of the Tape Recorder Output, then the recorder will receive whatever is on Channel B of the system (be it AM, phonograph, etc.). If a *stereo record* tape recorder is used, then a pair of leads will be required . . . one from Channel A and one from Channel B of the Tape Recorder Outputs. It is now possible to record stereophonically any program material being carried by the LK-48.

If your tape recorder has separate erase, record, and playback heads you can take advantage of the special monitoring provisions of the LK-48. This will be discussed under **TAPE MONITOR** operation.

## Tuner

To connect an AM or FM tuner, insert one end of a shielded lead into the audio output of the tuner and the other end into the Tuner input, Channel A on the back of the LK-48. The

\*Mag Low and Mag High cannot be used at the same time. Use either one set or the other.



**Stereo Selector** switch should then be set for *Channel A*, in order for the FM signal to appear at both speakers. If the tuner has a level control, this should be adjusted so that the overall volume does not vary when rotating the **Input Selector** from *Phono* to *Tuner*.

With H. H. Scott tuners, Model 310 B and 311 A, B, and C, both a high level (or audio) output and a low level (or tape) output are present. It is advisable to use the low level (or tape output) on these models. In addition, on Models 310 C, 311 D, 314, LT-10, and 320 there are sets of Channel A and Channel B outputs. With these tuners, connect one shielded lead from the Channel A output to the Channel A tuner input on the LK-48. Connect another lead from the Channel B output to the Channel B tuner input on the LK-48. With this exclusive H. H. Scott feature it is NOT necessary to turn the **Stereo Selector** to *Channel A* in order for the FM signal to appear at both speakers. The **Stereo Selector** switch can now be left in the *Stereo* position when using the tuner.

With stereo tuners, such as the H. H. Scott 330 or 331 series, the FM output is connected to the Channel A input, the AM is connected to the Channel B input. The same provisions concerning the high level and low level outputs on the tuner apply. If the tuner contains separate AM and FM level controls, these should be balanced with the phono input and with each other as well. With the H. H. Scott models 330 C and 330 D switching between AM and FM is controlled on the tuner. The LK-48 **Stereo Selector** can be left in *Stereo* position. With other makes, you may have to turn the **Stereo Selector** to *Channel A* for FM monophonic or *Channel B* for AM monophonic.

## Multiplex

If a multiplex adaptor is used with the LK-48, the connection instructions supplied with the adaptor should be followed. If a complete multiplex tuner is used, such as the H. H. Scott 350, connect the Channel A output of the tuner to the tuner Channel A input of the amplifier. Do the same with Channel B. Any special instructions supplied with the tuner should be carefully observed.

## Extra

The extra input can be used for any high level source such as tape recorder, TV, crystal microphone, phonograph with crystal or ceramic cartridge, etc. Instructions for connections were given under the section for connecting a record player with crystal or ceramic cartridge.

## Derived Center Channel Output

One of the many exclusive stereo features pioneered by H. H. Scott is the derived third (or middle) channel. This extra output is used in conjunction with an auxiliary amplifier to fulfill several important needs: 1. It gives fuller sound, particularly in large rooms where it is desired to separate speakers by more than eight feet. 2. It allows ideal seating for full stereo in a much greater portion of your listening room giving you greater freedom in placement of speakers and furniture. 3. It lets you feed a full signal to extension speaker systems in other rooms like kitchen, den, porch, bedroom or bath. With an ordinary two channel system you feed just half the signal to an extension speaker.

Connect the Derived Center Channel Output jack to the input of the power amplifier. Use the 1.5 volt input on all H. H. Scott power amplifiers and a high level input (such as tuner, extra, etc.) on complete amplifiers. Set the level control so that the center channel loudspeaker's sound is slightly lower in volume than the left and right stereophonic speakers. If the center channel is driving extension speakers, the individual loudspeakers can be equalized by using individual "T" pads on each speaker.

The center channel output is controlled by all the front panel controls. It is essential that the center channel speaker be in phase with the right and left channel speakers for proper operation. The proper method will be described later.

## Accessory Outlet

An accessory switched 117 volt outlet is available on the back panel to supply current for a phonograph or tape recorder motor. If more than one device is used, a 3-way plug should be inserted into the outlet, permitting the use of up to three devices. The outlet is rated at 5 amperes so the total current drain of all the devices connected should not exceed this amount. When the LK-48 is turned off, all items plugged into this outlet will also be turned off.

## DESCRIPTION AND USE OF CONTROLS

### On-Off Switch

The LK-48 is turned on by pulling the **Loudness Control** towards you. **IMPORTANT:** Unless the LK-48 is being used to play back tape, **Tape Monitor Control** must be in the *Out* position.

### Input Selector

This control selects the sound source for your system.

*Phono* — Switches on Mag Low or Mag High inputs.

*Tuner* — Switches in anything connected to the Tuner inputs.

*Extra* — Switches in anything connected to the Extra inputs.

### Stereo Selector

Controls the mode of operation of the LK-48.

*Bal A* — Both channels coming into the LK-48 are combined and sent only to the left speaker.

*Bal B* — Both channels coming into the LK-48 are combined and sent only to the right speaker.

(Use of these positions for balancing output will be discussed under **Stereo Balance**.)

*Monophonic Records* — If a stereophonic cartridge is being used to play monaural (or, more properly, monophonic) records, use this position. It automatically combines the dual outputs of the stereo cartridge, effectively cancelling out any vertical rumble and noise in the signal.

*Stereo* — Whenever the LK-48 is being used stereophonically, the control should be in this position.

*Stereo Reverse* — Basically this is identical with the above position except that it permits the user to "move the violins

from the left side of the orchestra to the right, and the drums from the right side to the left" if he desires.

*Channel A* — When switch is in this position, the Channel A signal source you selected with the **Input Selector** switch will play over both power sections and speakers. In other words, if the **Input Selector** is set to phono, Channel A of the phono will go through both amplifiers and into both speakers.

*Channel B* — Same as above, except that now the Channel B input source will be transmitted to both amplifiers and speakers.

## Channel A and B, Treble and Bass

These controls modify the sound to suit the user's taste, the room acoustics, and the program material being used. H. H. Scott provides a separate set of controls for each channel, permitting the operator to adjust for differences between speakers, and differences due to room placement. The bass control modifies the low frequencies, while the treble control modifies the high notes. Rotating the controls clockwise causes an increase in the amplitude of the frequencies, while rotating counter-clockwise causes a reduction.

Feel free to use these controls as you see fit. You are the one who must be satisfied with the over-all sound, and the tone controls are the principal way of seeing that you are. However, boosting the treble will accent surface noise on phonograph records and hiss on tapes, while boosting the bass will emphasize record player motor noise.

## Stereo Balance

Whether the system is being used stereophonically or monophonically, it is important that the sound from the two speaker systems be of equal volume. They may sound different because of any of the following reasons: room acoustics, differences in speaker efficiencies, differences in output between the two channels of a stereo cartridge, speaker placement, slight discrepancies between the two channels of the source material, and a multitude of other possibilities. The **Stereo Balance** is designed to correct this. By rotating the knob clockwise, the right or B channel will be increased in volume in comparison to the left or A channel. Rotating counter-clockwise will have the opposite effect. By moving the control to its extreme position, it is possible to completely eliminate one channel if desired.

To simplify the balancing operation, the LK-48 incorporates the unique H. H. Scott balancing circuit. Unlike other methods, this insures that you will *hear* equal sound level from each speaker system. Turn on any program material and rotate the **Stereo Selector** switch to *Bal A* and then to *Bal B*. Quickly switch back and forth between these two positions, while at the same time varying the **Stereo Balance**. At the position of the **Stereo Balance** where *Bal A* and *Bal B* sound equally loud, the system is in balance. Unless there are discrepancies introduced by faulty program material or cartridges, the control should not have to be varied appreciably.

## Loudness and On/Off

Pulling this control will turn on the LK-48. This control also varies the volume of sound emanating from the system. As the knob is turned clockwise, the volume will increase. Ordinarily, the control should be pointing to 2 or higher at normal listening level. The actual position is not important as long as it is at least 2. If the control cannot be turned past 1 without the sound becoming too loud, it would be advisable to make sure that the proper inputs are being used (refer to the section on Connections), and that the FM and AM level controls on your tuner are set properly.

## Loudness-Volume Switch

It is a phenomenon of the human hearing mechanism that

When volume is low, the ear is less sensitive to extreme low notes and extreme high notes. Thus, whenever the system is being operated at a low level, the sound will not seem to be as good as it is at higher levels. To compensate for this deficiency, the LK-48 incorporates a special circuit which automatically boosts the extreme lows and highs whenever the volume is reduced. To introduce this compensating network into the system, move the slide switch to *L*. When the sound level is increased, this compensation automatically decreases since it is no longer needed. When the switch is in the *V* position the compensation network is out of the circuit.

#### Tape Monitor Control

The control should always be in the *Out* position except when you are listening to the playback of tape, in which case it would be moved to *In*.

If your tape recorder incorporates a separate playback head it is possible to listen to the recording a fraction of a second after it is made as a quality check. Let us assume that a recording is being made from an AM-FM tuner. The **Input Selector** will be in the *Tuner* position. With the **Tape Monitor** control in the *Out* position, the system will be playing the actual broadcast. With the control moved to *In*, the system will now be listening to the tape recording of the broadcast as it is being recorded. By moving the control back and forth it is possible to hear whether the recording is equivalent to the actual broadcast.

This method will work only for recorders with separate record and playback heads.

#### Scratch Filter

If the surface noise of a phonograph record is particularly objectionable, move the **scratch filter** to *In*. It will reduce the high frequencies. On especially old records (such as 78's), it may be necessary to turn down the **treble controls**, too.

#### Equalization Switch

When using a record player, this switch should be in the *RIAA* position. When using a tape deck, the switch should be in the *NAB Tape* position.

#### PHASING THE LOUDSPEAKERS

A loudspeaker cone produces sound by moving back and forth, pushing the air in such a manner that our ears detect sound. When two loudspeakers are in operation in a stereo system, it is essential that the speaker cones move back and forth at the same time. If the right speaker is moving forward at the same instant that the left speaker is moving backward, there will be a noticeable reduction in bass response as well as a poor stereophonic effect.

To insure that the system is in phase at all times, the following method is suggested:

Tune in a monophonic broadcast with a male voice speaking, or else play a monophonic record with a male singing voice. Turn the volume to full room level. Stand in front of the two speaker systems and midway between them. Have someone quickly reverse the leads to one speaker. In one position, the voice will sound full and appear to be coming from directly between the two speakers. In the other position, the voice will lose some of its bass response, and will appear to be coming from both speakers. The first is the correct position, the second is the incorrect one.

If a center channel speaker is used, the same procedure can be employed except that the **Stereo Selector** should be turned to *Bal A*. The lead to the center speaker is then reversed until the center and left speakers are in phase. The only time it will be necessary to repeat the phasing operation is if one of the speakers should be disconnected for some reason.

RIGHT SPEAKER

## Connect Your New H. H. SCOTT LK-48

Easy as 1...2...3!

LEFT SPEAKER

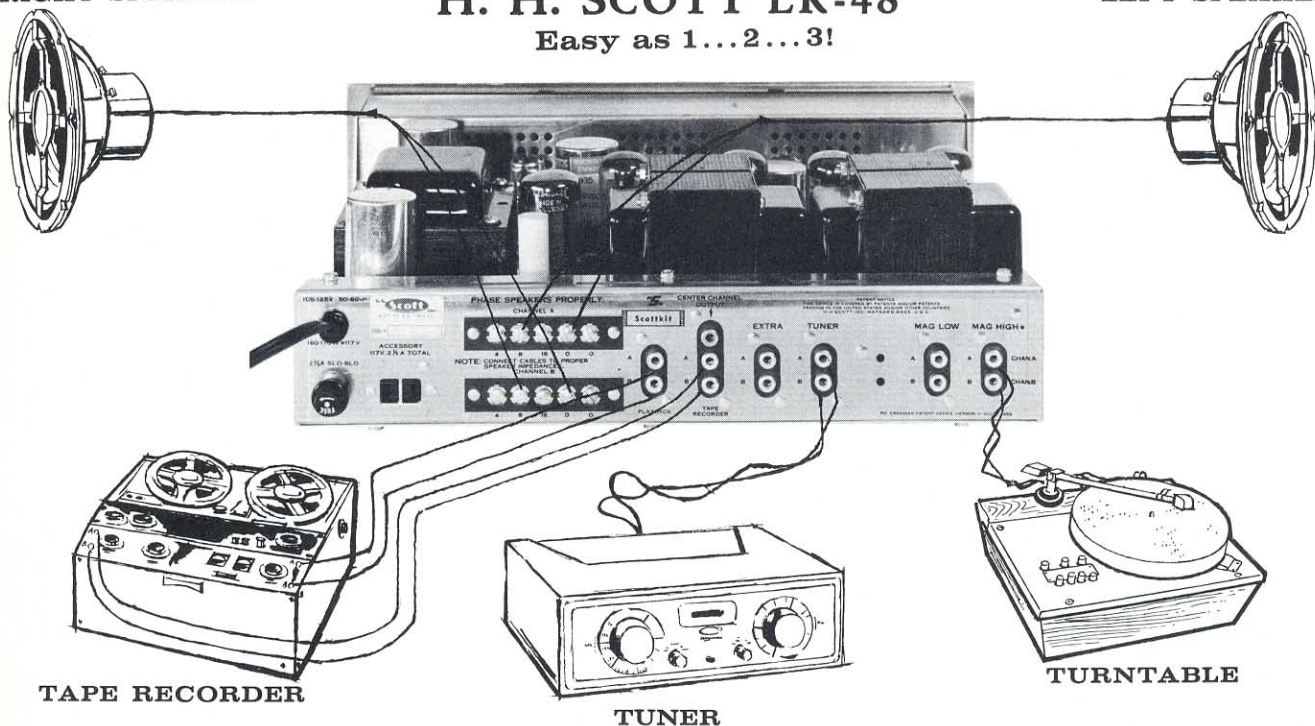

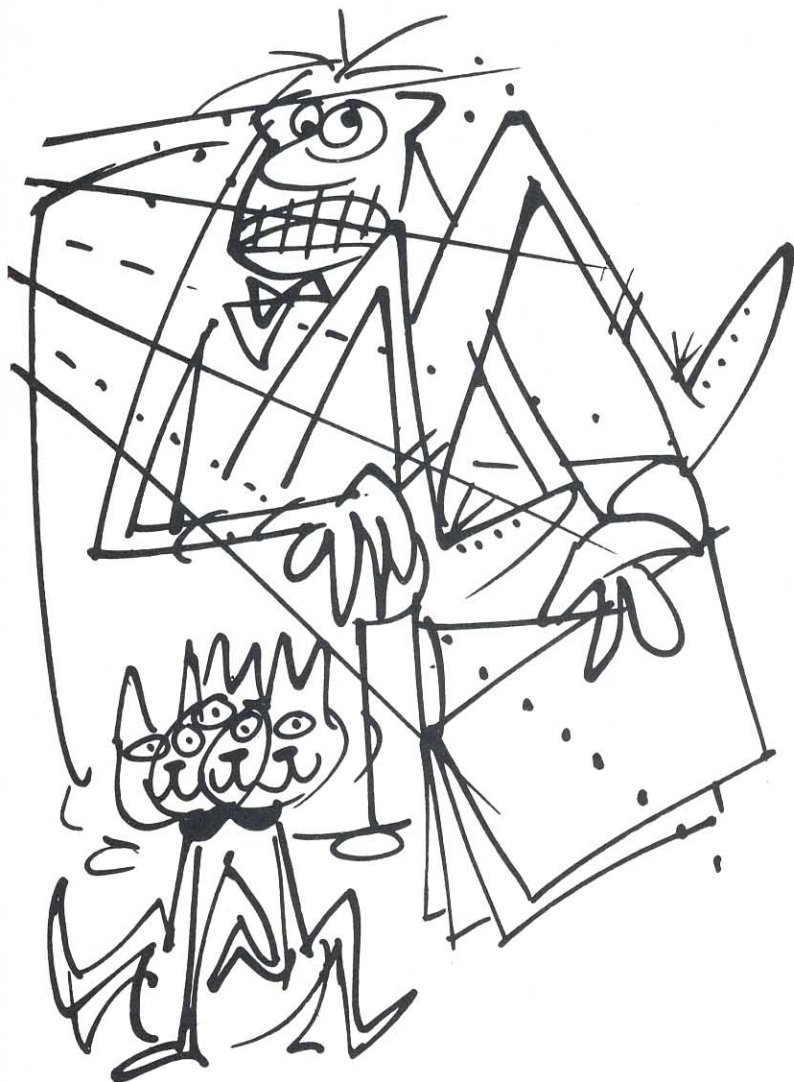

## In Case of Difficulty

No matter how careful you are, a mistake is possible. Don't panic! First, make sure each tube is in the proper location. Then go back to the assembly notes and check off each step with the written instructions and the pictorials. Or if possible, have someone else do this for you. Often a fresh approach may disclose mistakes that you might be consistently overlooking. While checking for errors, carefully probe each and every wire, lead, component, and part to make sure there are no short circuits or poor solder joints.

In case the fuse has blown (the tubes will not light up) it is very likely that there is a short circuit. Before replacing the fuse search for the cause.

In case the tubes light up but the unit does not operate properly voltage readings are supplied on the schematic. If you can obtain a good vacuum tube voltmeter (VTVM) use the voltage readings for locating the portion of the circuit that is malfunctioning.

As this is a stereo amplifier/preamplifier control center, it is possible that most of the unit will be functioning with sound heard from one channel but not the other. To help locate the portion malfunctioning when this occurs, try the following: (1) Connect speakers to both Channel A and Channel B speaker terminals on the rear. (2) Connect a stereo phono to Channel A and Channel B Mag inputs, or a tuner to both Channel A and Channel B tuner inputs. (3) Set the Input selector to either Tuner or Phono as the case may be. (4) Rotate stereo selector between Bal A and Bal B. If sound is heard in the Bal A position but not in Bal B, then the Channel B power amplifier section is not functioning (or vice versa). The introductory notes on Amplifiers will indicate what parts of the circuit make up the different amplifier and preamplifier sections. (5) Rotate stereo selector between Channel A and Channel B. If sound is heard in the Channel A position but not in the Channel B position, then the latter's preamplifier control center section is malfunctioning (or vice versa).

If none of the above suggestions help in curing the problem you should write to our Laboratory Kit Service Dept. for prompt assistance. There is no charge for this help. The engineers in this department are thoroughly familiar with all aspects of the kit, and can probably localize the cause of your difficulty. However, you must be very explicit in describing your problem. Mention all the approaches you have undertaken to cure it. Describe all the symptoms and signs that may be involved. With complete information supplied, the possibilities of a cure through the mail are greatly increased.

## Service

When all else fails the facilities of the H. H. Scott Laboratory Kit Service Department and the vast network of Authorized Warranty Service Stations are available to you. You will be charged a fixed fee of \$10.00 for each unit that is submitted either to the factory or to a Warranty Station within the warranty period. This fee will be in addition to any parts that have to be replaced. If the unit is still within the 90 day warranty period (see description of the Warranty Policy below), then the charge for parts will be governed by this policy. A list of warranty service stations is included with this kit.

Many H. H. Scott dealers have service facilities and are fully competent to repair this kit. These dealers are not governed by our price policy and can charge any fee they wish. This fee should be ascertained before service is begun.

The service policies described above only apply to completely assembled instruments constructed according to the instructions supplied. Any unit that is not complete, or has been modified in any way will not be accepted. Instruments showing the use of fluxes and acid core solder will also not be accepted.

# Warranty

To protect your investment, H. H. Scott, Inc. warrants that for a period of three months from the date of purchase, all parts shall be free of defects in materials and workmanship under normal use and service. H. H. Scott, Inc. will replace any defective parts upon the return of same to the factory, either by the customer, the dealer, or a warranty service station. There will be no charge for this replacement.

This warranty does not apply to any parts damaged during the course of handling and assembling the kit. No other warranty, either expressed or implied, shall apply to this unit.

## Packing For Shipping

If it becomes necessary to return the instrument to the factory, obtain a sturdy carton, large enough to hold the amplifier and place protective material around it. Crumpled newspapers, Kimsul, or similar packing material can be used. Make sure the amplifier is in tight so that it does not shake around. Mark: FRAGILE DELICATE ELECTRONIC EQUIPMENT on the

outside of the carton. Insure for its full value and ship, prepaid, by Railway Express to:

## Laboratory Kit Service Dept.

H. H. Scott, Inc.

111 Powder Mill Road  
Maynard, Mass.

## Choosing Your Tuner

Your new LK-48 is the finest amplifier kit available. It is designed with the precision that has made the name H. H. Scott a synonym for quality in the component field.

But a fine high fidelity system is only as good as its weakest link. Therefore we suggest that you invest in an H. H. Scott tuner when you are ready to expand your present system.

All H. H. Scott tuners are a perfect match to your new LK-48 both in appearance and performance. Where a tuner has knobs of different finish from your LK-48, an accessory knob kit is available for your tuner.

An ideal tuner would be the H. H. Scott LT-10 FM tuner kit. It is a perfect match to your LK-48, and is even easier to build.





Distinguished panel of musicians from Boston's famous symphony orchestra evaluate speaker performance in home of Hermon Hosmer Scott, Lincoln, Mass. Left to right, kneeling: Leonard Moss (Violin), James Stagliano (Horn), Berj Zamkochian (Organ), Everett Firth (Tympani). Standing: Bernard Zighera (Piano), Hermon Scott, Roger Voisin (Trumpet).

## Famous musicians first to hear remarkable new H. H. Scott speakers!

To assure perfection in his new speaker systems, Hermon Scott subjected them to home listening as well as technical tests. For the listening test he invited the most critical audience available . . . highly skilled professional musicians from Boston's famous symphony orchestra . . . to hear their *own* performances reproduced over the new H. H. Scott speakers. Here are their enthusiastic reactions:

*"The closest I have heard to the true sound of the violin. I was not even aware I was listening to a recording."* **Leonard Moss**, Violinist. *"The trumpet sound was uniform and consistent in every range, from the lowest to the highest note . . . a feat virtually unheard of in any other speaker."* **Roger Voisin**, First Trumpet; Recording Artist, Kapp Records. *"I have never heard any reproduction of organ which sounded so faithful to the original. I felt I was sitting in the center of Symphony Hall."* **Berj Zamkochian**, Organist. *"Every other speaker I ever heard sounded nasal and artificial. This was the first one that did not."* **Bernard Zighera**, First Harpist and Pianist. *"I was in the control room when this recording was made. Played through these new speakers, the reproduction was closer to the original performance than I've ever heard before."* **James Stagliano**, First Horn; Recording Artist, Boston and Kapp Records. *"The percussion came through with amazing clarity. The cymbals, the snare drum, the tympani and the bass drum all were equally true to the way they sound when I play."* **Everett Firth**, First Tympanist.

As with its tuners and amplifiers, H. H. Scott uses new techniques in both construction and testing that represent a significant advance in the state of the art. New construction methods assure excellence in performance . . . New testing techniques and quality controls substantially reduce variations in quality from speaker to speaker, common until now.

Every H. H. Scott speaker is individually tested to assure rigid adherence to specifications. Each speaker carries a 2 year guarantee. Hear the new S-2 and S-3 at your dealer soon. We are sure you will agree that these speakers are the finest musical reproducing systems ever made.

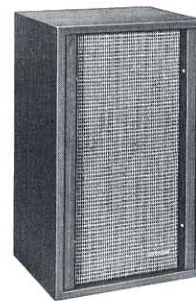

### H. H. SCOTT MODEL S-2 WIDE RANGE SPEAKER SYSTEM:

This four-driver, acoustic compliance system consists of a low resonance, high excursion mid-range units, and a special wide dispersion spherical tweeter mounted in a matched cabinet. Mid-range units acoustically isolated to eliminate undesirable coupling and intermodulation. Actual impedance 16 ohms. Dimensions: 23 $\frac{3}{4}$ " H x 14 $\frac{1}{2}$ " W x 12 $\frac{1}{2}$ " D. Available in mahogany, oil finish walnut, fruitwood and unfinished.



### H. H. SCOTT MODEL S-3 WIDE RANGE SPEAKER SYSTEM:

A three-way acoustic compliance system of true book shelf size. Consists of a specially designed low resonance woofer, a mid-range unit and a wide-dispersion super-tweeter mounted in a matched enclosure. Actual impedance 16 ohms. Dimensions: 23 $\frac{1}{2}$ " H x 11 $\frac{3}{4}$ " W x 9 $\frac{3}{4}$ " D. Available in mahogany, oil finish walnut, fruitwood and unfinished.

# LK-48 Parts List

## MECHANICAL PARTS

- 1 A-MC-2 . . . . . Main Chassis
- 1 A-RC-1 . . . . . Rear Chassis
- 1 LK-48-M2 . . . . . Front Chassis
- 1 A-BC-4 . . . . . Bottom Cover
- 1 A-CB-7 . . . . . Chassis Bracket
- 1 E-CS-13 . . . . . Control Shield
- 1 N-LK-48 . . . . . Front Panel

## HARDWARE AND MISC.

- 4 A-GR-9 . . . . . Rubber Grommets
- 1 E-LT-AVY . . . . . Solder Pack
- 1 E-LT-SD . . . . . Screwdriver
- 4 EV-9MA-1 . . . . . Tube Shield
- 2 F-SB-2.5 . . . . . Fuse
- 4 H-DLW-8 . . . . . Cup Washers (TR-12-3-2)
- 1 H-MS-632 x 1/4 B . . . . . Machine Screw (RWS-1)
- 12 H-N-3/8 x 1/2 . . . . . Pot and Switch Hex Nuts
- 4 H-N-832 . . . . . Nuts (TR-12-3-2)
- 8 H-NC-6 . . . . . Spring Clip Fasteners (TRA-8-5-1)
- 1 H-NK-632 . . . . . Lock Nut (RWS-1)
- 22 H-SMS-6 x 1/4 HW . . . . . Sheet Metal Screws
- 1 H-SMS-6 x 1/4 HW-B . . . . . Sheet Metal Screw (Bronze)
- 8 H-SMS-6 x 3/8 HW . . . . . Sheet Metal Screws (TRA-8-5-1)
- 1 H-T-342 . . . . . Terminal Lug
- 4 1-NS-2 . . . . . Nylon Sleeves
- 2 KN-P-6C . . . . . Knobs
- 2 KN-P-9C . . . . . Knobs
- 4 KN-P-8 . . . . . Knobs
- 1 XF-3AG . . . . . Fuse Post

## ELECTRICAL COMPONENTS

- 1 CEC-4 x 75/75 . . . . . Electrolytic (C1)
- 1 CEC-2 x 20/2 x 25 . . . . . Electrolytic (C2)
- 1 CEC-4 x 20/450 . . . . . Electrolytic (C3)
- 2 CC-.005 or CC-.0047 . . . . . Ceramic Capacitor
- 4 CC-.001 . . . . . Ceramic Capacitor
- 1 CC-.01/10KV . . . . . Ceramic Capacitor
- 2 CC-5 NPO . . . . . Ceramic Capacitor
- 6 CM15-47 . . . . . Mica Capacitor
- 2 CM15-82 . . . . . Mica Capacitor
- 2 CM15-180 . . . . . Mica Capacitor
- 2 CM15-220 . . . . . Mica Capacitor
- 2 CM20-560 . . . . . Mica Capacitor
- 2 CPM .25-200 . . . . . Tubular Capacitor
- 4 CPM .015 . . . . . Tubular Capacitor
- 6 CPM .022 . . . . . Tubular Capacitor
- 2 CPM .047 . . . . . Tubular Capacitor
- 10 CPM .1 . . . . . Tubular Capacitor
- 2 PEC 222E . . . . . Pkg. Elect. Circuit

A-GR-9



RUBBER GROMMET

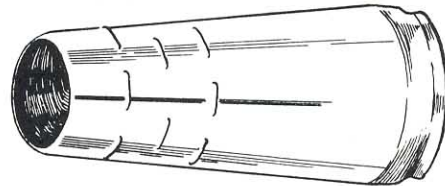

EV-9MA-1  
TUBE SHIELD



H-DLW-8  
CUP WASHER



H-N-832  
HEX NUT



H-NK-632  
LOCK NUT



H-SMS-6 x 1/4 HW  
SHEET METAL SCREW

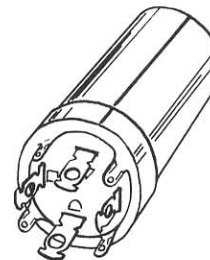

CEC  
ELECTROLYTIC  
CAPACITOR



H-N-3/8 x 1/2  
HEX NUT

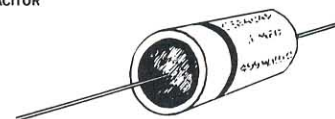

CPM  
MOLDED TUBULAR  
CAPACITOR



CC  
CERAMIC  
CAPACITOR

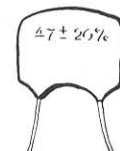

CM  
MICA  
CAPACITOR

4	RC21-1K	. . . . .	Brown/Black/Red	½ Watt Resistor
2	RC21-1.2K	. . . . .	Brown/Red/Red	½ Watt Resistor
4	RC21-1.5K	. . . . .	Brown/Green/Red	½ Watt Resistor
4	RC21-2.7K	. . . . .	Red/Purple/Red	½ Watt Resistor
4	RC21-10K	. . . . .	Brown/Black/Orange	½ Watt Resistor
1	RC21-15K	. . . . .	Brown/Green/Orange	½ Watt Resistor
2	RC21-22K	. . . . .	Red/Red/Orange	½ Watt Resistor
2	RC21-47K	. . . . .	Yellow/Purple/Orange	½ Watt Resistor
4	RC21-82K	. . . . .	Grey/Red/Orange	½ Watt Resistor
6	RC21-100K	. . . . .	Brown/Black/Yellow	½ Watt Resistor
2	RC21-150K	. . . . .	Brown/Green/Yellow	½ Watt Resistor
8	RC21-220K	. . . . .	Red/Red/Yellow	½ Watt Resistor
6	RC21-270K	. . . . .	Red/Purple/Yellow	½ Watt Resistor
6	RC21-330K	. . . . .	Orange/Orange/Yellow	½ Watt Resistor
1	RC21-680K	. . . . .	Blue/Grey/Yellow	½ Watt Resistor
4	RC21-1M	. . . . .	Brown/Black/Green	½ Watt Resistor
6	RC21-2.2M	. . . . .	Red/Red/Green	½ Watt Resistor
4	RC31-18	. . . . .	Brown/Grey/Black	1 Watt Resistor
2	RC31-68	. . . . .	Blue/Grey/Black	1 Watt Resistor
4	RC31-15K	. . . . .	Brown/Green/Orange	1 Watt Resistor
1	RC31-47K	. . . . .	Yellow/Purple/Orange	1 Watt Resistor
4	RC31-100K	. . . . .	Brown/Black/Yellow	1 Watt Resistor
1	RC41-2.2K	. . . . .	Red/Red/Red	2 Watt Resistor
1	RC41-4.7K	. . . . .	Yellow/Purple/Red	2 Watt Resistor
1	RW7-4K	. . . . .		Wire Wound Resistor
1	RW10-80	. . . . .		Wire Wound Resistor
1	RW10-1.2K	. . . . .		Wire Wound Resistor
1	RWS-20-8K	. . . . .		Stand Up Resistor
1	V-5AR4	. . . . .		Tube
4	V-7189	. . . . .		Tube
2	V-7199	. . . . .		Tube
4	V-12AX7	. . . . .		Tube

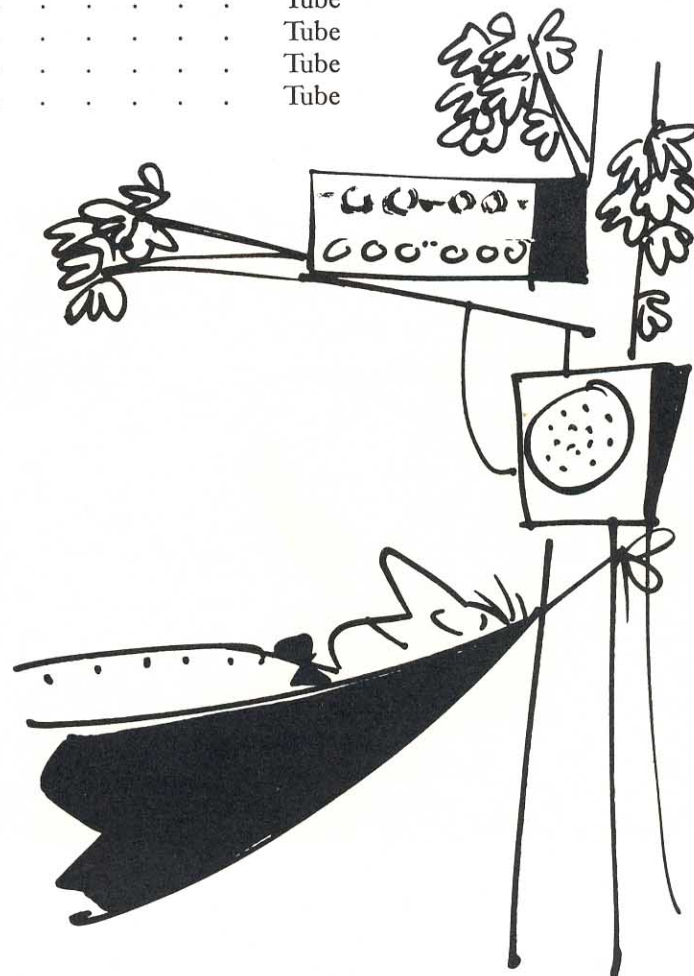
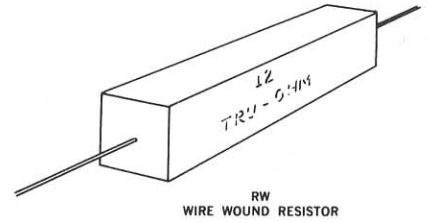
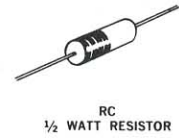
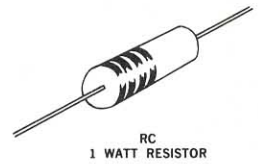

# H·H·Scott . . .

## a history of leadership in the Acoustic field

To insure that every H. H. Scott component meets the highest standards of quality, H. H. Scott maintains this ultra modern plant for the design and manufacture of all its components.

This new plant, located in Maynard, Massachusetts, includes a machine shop, sheet metal facilities, coil and transformer department, electrical assembly department and fully equipped laboratories for design and research.

The engineering department is staffed by 12 graduate engineers who are primarily concerned with developing new and better components for high fidelity sound.

Every high fidelity component receives over 50 electrical and mechanical tests before it leaves the factory. Special electrically shielded "screen rooms" are used for aligning FM tuners. There are life test facilities where components are run for thousands of hours under strict controls to test their durability.

These extensive investments in facilities back up H. H. Scott's philosophy that there will never be any compromise with quality.



