

# OPERATING

# MANUAL

## SCOTT STEREO AMPLIFIER

111 POWDER MILL RD, MAYNARD, MASS.



THE SCOTT

# LOOK HOW EASY IT IS TO OPERATE YOUR 222D, STEREO AMPLIFIER

This simplified photo-guide shows how to use your new amplifier. A similar guide on the inside back cover shows how to connect the amplifier to the rest of your music system. However, we strongly suggest that you read the complete

instruction book thoroughly. Only then will you get the utmost enjoyment and maximum performance from this superb instrument.

## TAPE

To listen to tape played on a regular Tape Recorder. (see page 15)

This switch can also be used to monitor a recording when used with a tape recorder with separate playback and record heads. (see page 15)

## SCRATCH

To reduce high frequency noises such as record surface noise. (see page 15)

## PILOT LIGHT

Lights up a few seconds after the unit has been turned on.

## SPEAKER

You can turn off the speakers if you want to use your headphones and not disturb others.

## POWER

To turn the amplifier on or off. Will also supply power to any device connected to switched AC outlet on the back. (see page 10)

## EQUALIZATION

RIAA phono is for phonograph records. NAB tape is only used when you listen to prerecorded tape on a Tape Deck which has no playback preamplifiers. (see page 11)

## INPUT

Phono—for phonograph records  
Tuner—for FM or AM tuner  
Extra—for any device connected to the extra inputs on back. (see page 11)

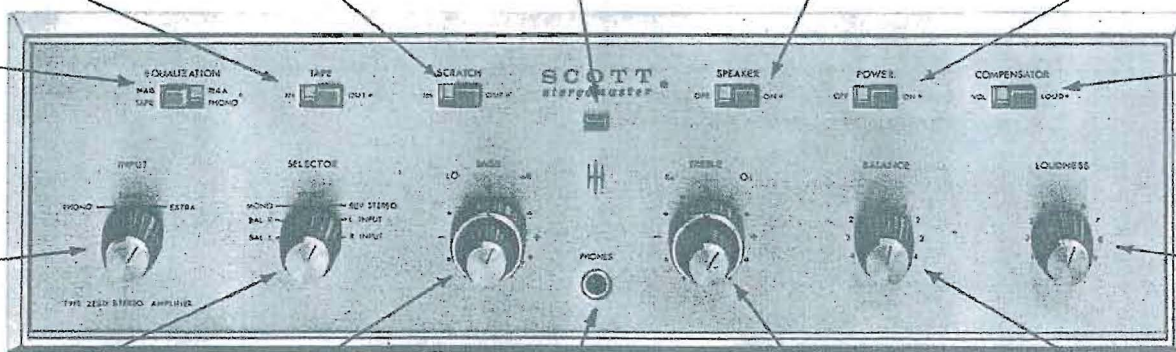

## COMPENSATOR

In "Loud" position introduces a circuit that boosts the extreme high notes and low notes for listening at low levels, and is out of operation automatically at loud levels. "Vol." position removes circuit completely. (see page 13)

## SELECTOR

For all stereophonic program material, set to Stereo position. Other positions are for monophonic material, or for balancing the system. (see page 13 and 12)

## BASS

Modifies low frequency sounds. Set to suit your taste. (see page 14)

## PHONES

To connect a set of low impedance stereo headphones. (see page 5)

## TREBLE

Modifies high frequency sounds. Set to suit your taste. (see page 14)

## BALANCE

To make one speaker louder than the other. Permits you to adjust for unequal sounds caused by room acoustics or faulty program material. (see page 13)

## LOUDNESS

Makes system louder or softer to suit your taste. (see page 13)

## HERE'S WHAT MAKES SCOTT AMPLIFIERS SO OUTSTANDING

The first true high fidelity amplifier was Scott's world famous 210A which appeared in 1947. This remarkable instrument introduced a score of unusual design features which today are accepted and used by all manufacturers. The engineering innovations in the 210A are typical of H. H. Scott, a company which has continued to pioneer in the audio field. The exceptional design and careful manufacture that went into the 210A have been proven over the years . . . most are still in service — working perfectly.

Scott's philosophy is not only to develop new and better instruments, but also to produce equipment that will last. There is no built-in obsolescence in Scott products. Here are a few of the "extras" Scott has included in your new amplifier:

- Non-magnetic electrolytic aluminum is used as chassis material on all Scott amplifiers rather than low cost steel. Aluminum acts as a shield against induced hum, and is an ideal heat dissipator guaranteeing long life and cool operation of the vital output stages.
- To avoid unpleasant hum and noise, Scott uses specially selected preamplifier tubes.
- All Scott amplifiers are 100% stable with any type of load or with no load. You never have to worry about harming your amplifier if a speaker wire is disconnected.
- The oversized output transformers on all Scott amplifiers mean that you will get plenty of output power at the low frequencies where power is really needed. Any amplifier can meet its rated specifications in the midrange. It is in the vital low frequency region that Scott amplifiers stand out as the leaders.

- All Scott amplifiers incorporate a subsonic sharp cutoff filter. This prevents all noise and rumble below 20 cps from entering the amplifier stage and causing the amplifier to waste its power on undesirable noises. By concentrating on the audible range, a Scott amplifier gives usable power far in excess of its conservative rating.
- All components and parts are carefully checked. They are used far below their rated values. You can be sure that your new Scott amplifier will meet its specifications, both now and for years to come.

Your new Scott amplifier is an investment in years of trouble-free, listening pleasure. To maximize this investment read this booklet carefully and follow the easy directions exactly. If you have any questions or if any problems arise, please refer to the address at the back of the booklet and write immediately. Scott feels that its responsibility for your satisfaction is just beginning now that you have purchased one of our instruments.

## INSTALLING YOUR SCOTT AMPLIFIER

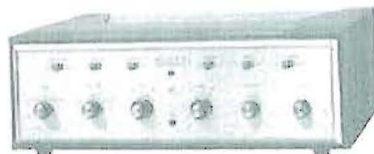

Your Scott amplifier<sup>1</sup> can be placed on a table or bookshelf, in existing furniture like an end-table, buffet, or room divider, or in a specially designed equipment cabinet. A handsome hand rubbed wood accessory case is available from your dealer in finishes to blend with your decor.

## CONNECTING YOUR SCOTT AMPLIFIER To A Stereo Speaker System

Terminal strips for speaker connections are located on the rear of your amplifier. The screws marked Right are for connecting the right-hand speaker (as you face them from your listening area), the ones marked Left are for the left hand speaker. Every speaker is rated by its manufacturer at a certain impedance. This information is either marked on the speaker or can be supplied by your dealer. You will note that there are screws marked 4, 8, and 16 on the terminal strips. These numbers indicate the correct connection to the loudspeaker, and permit you to match the output of your amplifier to the impedance of the speaker.

When making connections, you can use almost any type of wire if the lengths are under 50 feet. We highly recommend ordinary lamp wire (#22 wire according to the electrical code). If you want to run the wire under a rug you can also use flat TV antenna wire. If you plan to use wire lengths considerably in excess of 50 feet, it is advisable to use #18 wire to prevent excessive losses of power.

When attaching the wire to the amplifier or the speaker be certain that strands of wire from one screw do not accidentally touch strands on any other screw or the speaker will not perform properly. After the speakers are connected they should be properly phased to give a well-spread stereo effect with full bass. Phasing instructions are to be found at the back of this manual.



Wherever it is placed, adequate provision should be made for ventilation. If this is not done, the life of the internal components will be appreciably shortened. By adequate ventilation we mean about 4" of space above and behind the unit where air may circulate freely, or if it is installed in a cabinet, the cabinet should have an open back.

To help disperse heat rapidly, Scott employs aluminum in the construction of the chassis and panel. Aluminum is an excellent conductor of heat. Therefore, the panel may seem warm to the touch. As long as the unit is adequately ventilated, this is of no consequence.

The amplifier should always be mounted horizontally because of the necessity for proper heat dissipation. If vertical mounting is desired, forced air ventilation with a fan is a must. Fans specially designed for this purpose can be obtained from your dealer.

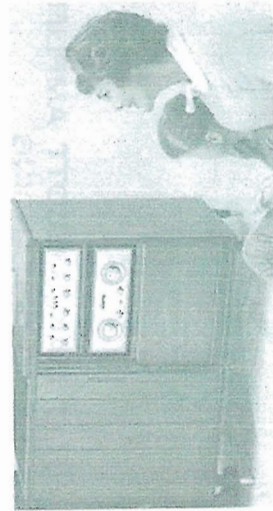

If the amplifier is to be installed in the same cabinet with an FM tuner, always place the amplifier above the tuner or alongside it. Never mount it below the tuner, as the heat from the amplifier will cause drift in your tuner.

If you would like to connect more than one stereo speaker system to your amplifier, you can readily obtain an inexpensive switching box from your dealer that permits you to switch between stereo speaker systems in different rooms.

### Making the Speaker Connections (209 and LK-30 series)

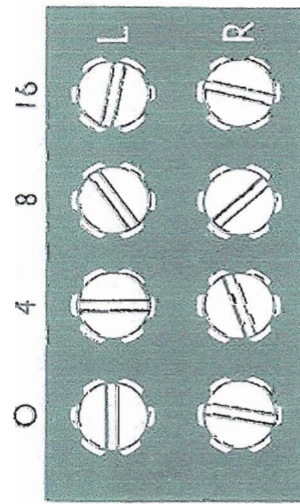

Connect one end of the speaker wire to the two terminals on the back of the left hand speaker or speaker enclosure. At the other end connect one lead to a "0" screw on the left terminal strip (if more than one "0" terminal is present, use either, they are identical) and the other to the screw number closest to the value of the loudspeaker impedance. Repeat for the right hand speaker.

(222, 209, LK-48, LK-72 series)—

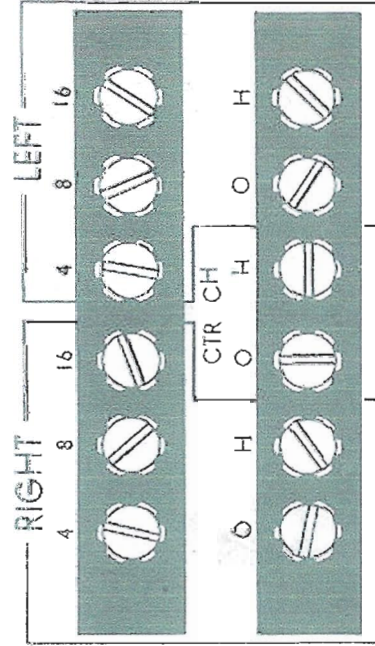

Your amplifier includes two terminal strips on the rear. The upper strip is designed solely for setting the amplifier to match the impedance of your speaker. Connect the cables with the spade lugs on the end to the terminal screw (either 4, 8, or 16) that most closely coincides with the rated impedance of your speaker. One cable and set of screws are for the right speaker and one for the left speaker. By having two sets, you can match impedances properly even if you are using speakers with different impedances.

The bottom terminal strip is for connecting the speaker wire. Connect one end of the speaker wire to the two terminals on your left hand speaker or speaker enclosure. Connect the other end to the "0" and "H" terminals for the left channel. Repeat for the right hand speaker.

### To A Single Speaker System

If you only own one speaker system and plan to add a second speaker for stereo at a later date treat the single speaker as a left channel speaker and operate the amplifier with the Selector in the Bal L. position at all times. It is not safe to operate conventional amplifiers without a speaker load. However, all Scott amplifiers are completely stable with resistive, capacitive, inductive, or no load. You need never fear injury to your amplifier by using it with no load on the right channel. Do not attempt to parallel the outputs of the amplifier. Such a procedure may reduce the power output and increase the distortion.

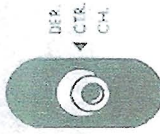

plifier to the input of a separate power amplifier. Use the 1.5 volt input if it is an H. H. Scott power amplifier and a high level input (such as tuner, extra, etc.) on any complete amplifier. Set the level control so that the center channel loudspeaker's sound is lower in volume as compared with the left and right stereophonic speakers. If the center channel is driving extension speakers, the separate loudspeakers can be equalized by using individual "T" pads on each speaker. A "T" pad is a specially designed level control that is readily available from your dealer.

### To a Center Channel Speaker or Monophonic Extension Speakers

One of the many exclusive stereo features pioneered by H. H. Scott is the derived third (or center) channel. This extra output is used in conjunction with an auxiliary amplifier to fulfill several important needs: 1. It gives fuller sound, particularly in large rooms where it is necessary to separate speakers by more than eight feet. 2. It allows ideal seating for full stereo in a much greater portion of your listening room giving you greater freedom in placement of speakers and furniture. 3. It lets you feed a full monophonic signal to single extension speaker systems in other rooms like kitchen, den, porch, bedroom or bath. With an ordinary two channel system you feed just half the signal to an extension speaker.

### Derived Center Channel Preamp Output Jack

Connect a shielded audio cable from the Derived Center Channel Output jack (labeled "Der. Ctr. Ch.") on the back of your Scott am-

The center channel output is controlled by all the front panel controls, therefore, the auxiliary amplifier should have a volume or level control to be able to obtain the proper balance. It is essential that the center channel speaker be in phase with the right and left channel speakers for proper operation. See section on phasing found later in the manual.

### Powered Center Channel Output

(222, 209, LK-48, LK-72 series)

In addition to the derived center channel output described above, these amplifiers also provide a powered center channel output capable of directly driving center channel or extension speakers. Connect one end of the speaker wire to the two terminals on the back of the speaker system. Connect the other end to the "Q" and "H" terminals under Center Channel (on the same strip that you cen-

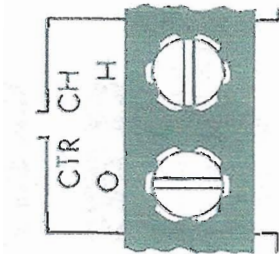

nected the right and left speakers). If this output is to be used as a center channel, then the speaker should be in phase with the right and left speakers. Phasing instructions will be found in the back of the manual.

Using the derived center channel preamp output described in the previous section provides greater flexibility, depending on the power of the separate amplifier. If many expansion speakers are desired, this method is preferable. However, for most normal requirements, the powered center channel output is certainly adequate and more convenient in that a separate amplifier is not needed.

#### Front Panel Stereo Headphone Output

A low impedance headphone output jack is located on the front panel. This jack will accept the standard three conductor phone plugs found on most popular low impedance stereo headphones. When using this jack, make sure that it is pushed in firmly.

(200/LK-50) When the headphone plug is connected to the front panel headphone output jack, the sound level from the loudspeakers will drop considerably. This allows you to obtain the full benefit of stereo headphone listening without interference from the sound of the loudspeakers.



PHONES

(200D, 222D, LK-72, LK-78) When the headphone plug is inserted in the front panel headphone jack, the Speaker switch on the front panel should be switched to OFF position. This will completely cut out the sound from the loudspeakers permitting private headphone listening. If desired, the speakers and the headphones can be operated simultaneously.

#### CONNECTING TO LOW LEVEL INPUTS

##### Stereo Record Player with Magnetic Cartridge

Magnetic cartridges are generally considered the best for faithful reproduction of the sound in the record groove. However, their electrical output is very small, on the order of a few millivolts (thousandths of a volt). The output is so small that your amplifier incorporates a special circuit known as a preamplifier section, specially designed to give this tiny signal a large boost before it goes into the regular power amplifier section.

##### 200 and LK-50 series —

Connect leads from your record player to the Mag. inputs on the back of the amplifier. The lead carrying the left channel signal is connected to the Left input, and the one carrying the right channel goes to the Right input. When you wish to hear records, switch the Input on the front to Phono.

CERAMIC      MAG.  
R.      L.      R.      L.



##### 222, 299, LK-58, LK-72 series

There is a wide variation in output from one make and model of magnetic cartridge to another. Some cartridges produce outputs as low as 3 millivolts while others are over 12 millivolts. If the pre-amplifier is designed to amplify only a 3 millivolt signal, a 12 millivolt cartridge will overload the amplifier and create too much

volume (at higher distortion). On the other hand, using a 3 millivolt cartridge with an input designed for 12, will not provide adequate listening volume.

Scott engineers have solved this problem by designing two different sets of inputs — one designed for low output magnetic cartridges and one designed for high output magnetic cartridges. If your cartridge has an output of 6 millivolts or less, use the Mag Low inputs. If it has an output of 7 millivolts or higher, use Mag High. Most cartridges will be used in the Mag High inputs.

Information on cartridge output is undoubtedly listed in the literature that came with it. If it is not, your dealer can supply the needed information.

#### 227. LK-72, LK-73 series —

To connect a turntable or changer utilizing a magnetic stereo cartridge, connect the shielded leads from the player to the Magnetic inputs on the back of the amplifier.

Check the instructions provided by the record player manufacturer to be certain that you are inserting the left channel lead into the left input of the amplifier and the right input into the right channel.\*

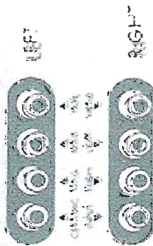

#### 299 series —

The 299 is especially flexible as to number and type of low level signals that can be connected to the amplifier and switched from the front panel. On the back of the amplifier you will find two sets of low and high mag inputs. There is a Mag 1 High and Low, as well as a Mag 2 high and low. This for example, permits you to connect both a turntable and a record changer. By moving the Pickup switch on the front panel between 1 and 2, you can choose between the two units.

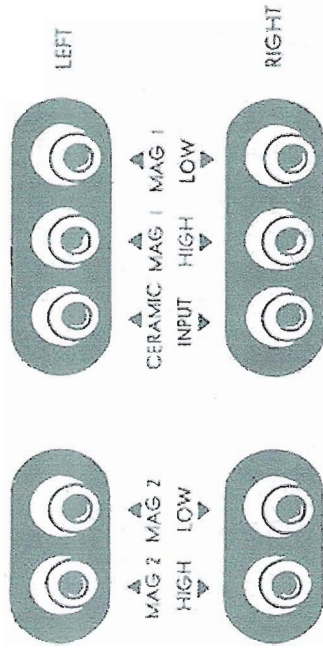

Check the output from your cartridge and connect the leads from the turntable to either Mag 1 high or low.\* Insert the leads from the left channel into the Left input and those from the right channel into the Right input. If you have a second turntable or changer, repeat this procedure by using the Mag 2 high or low inputs.\*

#### Stereo Record Player with Ceramic or Crystal Cartridge

A ceramic or crystal cartridge differs from a magnetic cartridge in the amount of output generated. Whereas a magnetic cartridge produces a signal of a few thousandths of a volt, a ceramic or crystal cartridge is capable of outputs of at least one half volt. For this reason, your Scott amplifier provides a special high input.

\* Use either Mag High or Low. Do not use both Mag High and Low at the same time.

When using a ceramic or crystal cartridge, the inputs marked Ceramic on the rear of the amplifier should be used. The lead carrying the left channel information should be connected to the Left Channel Ceramic input; the lead carrying the right channel information should be connected to the Right Channel Ceramic input.



(222D, 299, LK-32, LK-35) Either the ceramic or magnetic high and low inputs may be used; not all three at the same time. In other words, if you are using a ceramic cartridge connected to the Ceramic inputs, neither Magnetic High or Magnetic Low may be used.

(299D) Mag 1 high or Low should not be used if you are using a Ceramic cartridge. The Pickup switch on the front panel must be in "1" position, Mag 2, High or Low, can, of course, be used for any other low level device.

### Monophonic Record Player

The instructions outlined above for your amplifier are equally valid here. The only difference is that there will be only one lead to connect and this should be inserted in the Left input. To play the monophonic record so it is heard over both loudspeakers, turn the Selector switch to L. Input.

### Stereo Tape Deck

(222, 299, LK-38, LK-72 series) A tape deck is a purchase without playback preamplifiers. The signal is fed directly from the tape heads without any additional amplification. A very small electrical

signal is produced similar to that obtained from a magnetic phonograph cartridge. With your Scott amplifier you can connect both a tape deck and a record player, and select either from the front panel.

222, LK-38, LK-72 series — Connect the leads to the Tape Head input on the back panel. To listen to tape, move the Equalization switch to the NAB Tape position. This will switch the input from phono to tape head. The input must be in the Phono position in order to listen to either the tape head or record player.

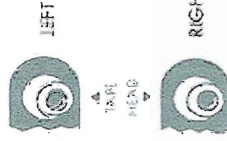

299 series — Connect the leads to either Mag 1 low or Mag 2 low. If your magnetic cartridge is connected to either Mag 1 high or low, then use Mag 2 low.\* The Pickup switch in the front panel will permit you to choose between the record player and the tape deck. In addition, set the Input selector to NAB tape to get the proper sound. More about this in the section on "Equalization."

### Microphone

(299 series) — A microphone can be connected in much the same way as a tape deck or a magnetic cartridge. Use either Mag 1 or 2 high or low.\* The Pickup switch on the front will permit you to choose between the microphone and some other low level source. When using the microphone, turn the Input selector to the Mic position. This will assure the proper balance of sound. For more information, see the section on "Equalization."

\* You cannot use Mag 1 high and low, or Mag 2 high and low at the same time.

### Grounding Your Record Player or Tape Deck

Many turntables, changers, and tape decks must be grounded to reduce hum to unobjectionable levels. A copper colored screw will be found on the top rear of your amplifier. A few turns with a screwdriver will loosen it. Connect any grounding wires to this screw, and then tighten. Carefully read all the instructions provided with your cartridge, record player, or tape deck relating to hum reduction. If unusual problems present themselves write to the address given at the back of this manual.

### CONNECTING TO THE HIGH LEVEL INPUTS

#### Stereo Tuners (or monophonic tuners with multiplex adaptors)

Whether you use an integrated stereo tuner or a monophonic tuner with a multiplex adaptor, you will have two leads to connect to the amplifier. One lead will carry the left channel information and this should be connected to the left channel Tuner input. The one carrying the right channel information should be connected to the right Tuner input.

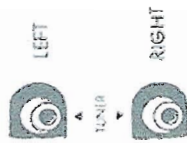

If the tuner has a level control it should be adjusted so that the overall loudness does not vary when switching between records and tuner. If your tuner does not have a level control, but does have a choice of outputs marked high or low, use the outputs most closely matching the over-all loudness when playing records.

### Monophonic Tuners (AM or FM)

Some early Scott FM tuners (like the 310D, 314, LT-10, 311D) have pairs of outputs on the back. Connect the one marked Channel A output to the left channel Tuner input of the amplifier. Connect Channel B to the right input. While you are not feeding a stereo signal into the amplifier, you will be able to leave your amplifier in the stereo mode at all times and still get monophonic sound from both speakers.

If your tuner has only a single set of outputs (perhaps one is marked audio or amplifier output and the other is called tape), connect a single lead from the audio output to the left channel Tuner input of the amplifier. In order to hear monophonic sound from both loudspeaker systems, turn the Selector switch on your amplifier to L. Input.

#### Extra Input

(222, 299, LK-48, LK-72 series) — An extra stereo input is provided for any other high level source you may wish to connect to your amplifier. You can connect a second tape recorder, ceramic

microphone or cartridge, or sound from your TV set. If this extra source is a stereophonic device with two leads, connect the left channel lead to the left channel Extra input and the other to the right channel Extra input. Set the Input selector to Extra. If it is a monophonic device with only one lead, connect it to the left channel Extra input. To listen to this latter signal over both

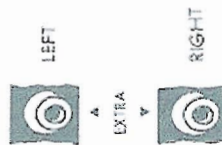

speakers you should turn the Selector switch to L. Input position and the Input selector to the Extra position.

## CONNECTING YOUR TAPE RECORDER

### To Make Tape Recordings

Your Scott amplifier has a special set of outputs which permit you to record any signal passing through the amplifier. You can make tapes from your records or off-the-air from a tuner. The tape recorder output is completely unaffected by the volume and tone controls of the amplifier. If you want to turn the volume down to "0", you can and it will not affect the output to the tape recorder.

Connect an audio cable from the left channel Tape Output on the amplifier to the left input of the tape recorder. Repeat for the right channel. Some tape recorders have both a high level (or tuner) input and a low level (or microphone) input. Use the high level input for all connections from the amplifier.

If there is any question, refer to the recorder instructions and follow accordingly.

If you have a monophonic tape recorder, connect the left channel Tape Output of the amplifier to the tape recorder.

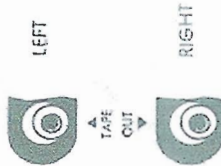

Tape Input jack on your amplifier. Repeat for the right channel. In order to listen to the tapes, slide the Tape switch on the front panel to the IN position. When the tape switch is in this position, it completely bypasses the Input switch and permits you to hear the tapes regardless of the position of that switch. When you are finished listening to the tapes, immediately return the Tape switch to the OUT position so that the Input selector becomes operative again.

If you are listening to a monophonic tape recorder connect the tape recorder's output cable to the left channel Tape Input jack. Use the Tape switch as described above, but in addition, turn the Selector switch to L. Input so that the sound can be heard over both speakers.

If your tape recorder has a separate record and playback head, it may be possible to monitor the tape while you are making a recording. This will be described in the section on TAPE MONITOR.

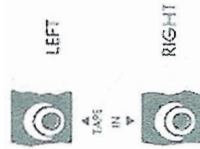

## POWER

The power cord should be plugged into any 105 to 125 volt, 50 or 60 cycle AC source (wall outlet). Do not attempt to use with a DC outlet.

### Accessory AC Outlets

Accessory AC outlets are found on the rear of your Scott amplifier.

### To Playback Tape Recordings

If your machine has no playback preamplifiers, it is feeding a signal directly from the tape heads to the amplifier without any additional amplification. Such a device is commonly called a tape deck and its use is covered under "Low Level Inputs" on a previous page.

If your stereo tape recorder has its own playback preamplifier, connect an audio cable from the left channel output to the left channel

(299D, 222D, LK-72, LK-48) There are two accessory AC outlets on the rear panel. One of the outlets is controlled by the front panel On-Off switch and is colored black. Your tuner, tape deck or recorder may be plugged into this outlet. When you turn off your amplifier anything plugged into this outlet will automatically be turned off as well.

The second accessory AC outlet (colored red) remains "live" as long as the amplifier itself is plugged in. It is suggested that your record player be connected to this outlet. This will insure that no rumble-producing "flat spot" will occur in your record player if you turn the amplifier off before the record player has completed its cycle. When this output is used you must independently shut off the device plugged into it.

An accessory switched 117 volt output is available on the back panel to supply current for a tuner or tape recorder motor. If more than one device is used, a 3-way plug should be inserted into the outlet, permitting the use of up to three devices. The outlet is rated at 2½ amperes so the total current drain of all the devices connected should not exceed this amount. When the amplifier is turned off, all items plugged into this outlet will also be turned off.

## HOW TO USE YOUR SCOTT AMPLIFIER

Your new Scott amplifier has a wide variety of controls. Yet, it is extremely easy to operate. Most of the controls are only used occasionally. The two indispensable operating features are the Input selector and the Volume (or Loudness) control. The former permits

you to choose between different sources, such as phono or tuner. The latter allows you to vary the overall loudness to suit your taste. Become familiar with these immediately.

### Turning the Amplifier On

**LK-48 and LK-72** — Turn the Loudness control clockwise. This will turn the amplifier on as well as provide power to any instruments connected to the switched accessory outlet on the back. The pilot light on the front of the amplifier will light up a few seconds after the unit has been turned on.

**299, 222, 299 series** — A separate on-off switch is provided. This permits you to leave all the front panel controls in their normal operating position without having to reset them. When the amplifier is turned on, power will also be provided to any instruments connected to the switched accessory outlet on the back. The pilot light on the front panel will light up a few seconds after the unit is on.

LOUDNESS

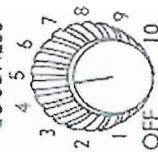

operating position without having to

POWER



### Choosing the Source

**NOTE:** To listen to (or play back) a tape recording, slide the Tape switch to the IN position. In this position, the Input selector is completely bypassed. Immediately return the Tape switch to OUT as soon as you are finished with the tape. Otherwise, it will be impossible to listen to any other source. Anytime the amplifier appears to be inoperative, check to make sure someone hasn't accidentally left the Tape switch in the IN position.



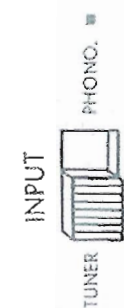

**200 and LK-30**—The input selector switch chooses between phono and tuner. (Any high level signal such as TV sound can be used in the Tuner input if desired.)

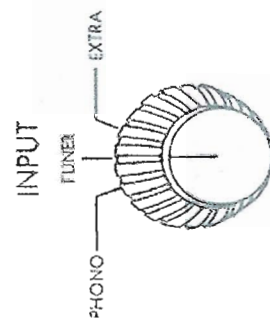

**222, LK-48, LK-72 series**—The three position rotary switch offers a choice of phonograph, tuner, or extra.

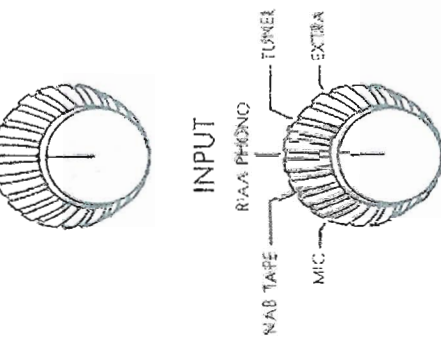

**299 series**—Starting with the control in the extreme counter-clockwise position, the first three positions automatically select the low level inputs on the back of the amplifier. To choose between Mag 1 (high or low) or Mag 2 (high or low) use the Pickup switch on the front panel. While all three positions of the input selector choose the same inputs, they do affect the signal in different ways. This will be explained in greater detail in the section on Equalization. However, you use the Mic position for a microphone, NAB tape when listening to a tape deck, and RIAA when using a record player. The next position is for tuner, and the last is to select any high level source (TV, Crystal Microphone) that might be connected to the Extra input.

### Equalization

In the process of making a disc or tape recording, the engineers have found it expedient to deliberately reduce the low frequencies and boost the high frequencies. This makes it possible to get more music on the record and reduce annoying background hiss and surface noise. To return the overall frequency response to normal (flat), your amplifier must incorporate a corresponding amount of bass boost and treble cut. This process is referred to as equalization.

To perform its function properly the equalization curve used in the amplifier must correspond exactly to the one used in making the recording. Since 1956, all phonograph records have been made with what is known as the RIAA equalization curve. All Scott amplifiers made since 1951 incorporate this equalization curve. If you have a few older records which may have been made using slightly different curves, small adjustments of the tone controls can easily correct for proper response.

**(200 and LK-30 series)**—The RIAA curve is built into your amplifier and automatically takes effect whenever you operate the system in the phono position.

**222, LK-48, LK-72 series**—When you put the Equalization switch on the front panel in the RIAA phono position, it will automatically switch the record player into the circuit with the proper RIAA equalization.

In addition to this feature, your amplifier provides an additional equalization curve specially designed for playback of pre-recorded tape from a tape deck. A tape deck does not include playback preamplifiers and signal is fed directly from the tape head to the amplifier without additional ampli-

### EQUALIZATION



fication. If you have such a device, connect it to the Tape Head input on the back of the amplifier and move the Equalization switch on the front panel to the NAB tape position. This will switch the tape head input into the circuit and simultaneously provide the proper tape equalization.

**NOTE:** In order to use the Equalization switch and to listen to either records or tape (as played on a tape deck), the Input switch must be in the Phono position.

#### Equalization and Pickup Switch

*299 series —*

The 299 series provides unparalleled flexibility in the number and type of signal sources that can be used. As described in the section on "Connections", two turntables, record changers, tape decks, microphones or combinations thereof can be connected to the amplifier and selected from the front panel by means of the Pickup switch. In position "1" it switches into the circuit any device connected to either Mag 1 High or Mag 1 Low on the back panel. In position "2" it does the same for any device connected to Mag 2 high or Mag 2 low.

After you have turned to the proper Pickup switch position you must select the proper equalization position on the Input selector. If you are listening to records played on a turntable or a record player with a magnetic cartridge, then the Input selector should be in the RIAA position.

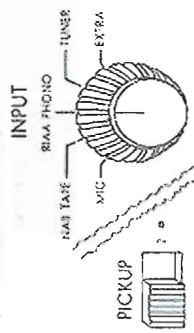

If you are listening to pre-recorded tape with a tape deck, then the NAB position on the Input selector is required. A tape deck is a device that does not have playback preamplifiers. The signal is fed directly from the tape head to the amplifier without additional amplification.

If you are using a microphone, the Input selector should be set to Mic. A microphone does not require any equalization but it does need a big boost in volume. With the switch in the Mic position the signal will get lots of amplification without frequency equalization.

#### Selector

This versatile switch controls the mode of operation of your music system. If you are primarily interested in stereo program material, the switch will usually be in the Stereo position. If you occasionally play monophonic records or other monophonic material, it is an excellent idea to familiarize yourself with the various positions of this control. Starting in the extreme counterclockwise position:

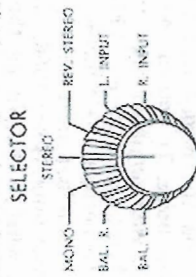

**Bal L.** — signals coming in on both left and right inputs are combined in the amplifier and then sent out to the left speaker only.

**Bal R.** — signals coming in on both left and right inputs are combined in the amplifier and then sent out to the right speaker only.

(These two positions are part of Scott's patented balancing network . . . an easy way to match the loudness of your right and left speakers perfectly. Their use will be discussed in the section on "Balancing The System.")

**Mono** — If a stereophonic cartridge is being used to play monophonic records, use this position. It automatically combines the outputs from the left and right channels of the cartridge into a single monophonic signal. In the process of combining the two channels, noise and rumble present in the original record, and noise caused by vertical motion in your stereo cartridge is cancelled, resulting in much cleaner reproduction of your mono records.

**Stereo** — This is the normal position for this switch and should be used for listening to stereo program material of all types.

**Rev. Stereo** — Basically this is identical to the stereo position except that it reverses the two channels. The Left input will now be heard over the right hand speaker, and vice versa. This can be used, for example, to move the violins from the left side to the right, . . . the drums from the right to the left . . . if you so desire.

**L. Input** — Any Left input signal will be fed through both amplifier channels and into both loudspeakers. This is useful if you have a monophonic cartridge or tuner connected to the left input of the amplifier. By using this position you can hear this single source over the full dual channel music system.

**R. Input** — Any Right input signal will be fed through both amplifier channels and into both loudspeaker systems.

### Loudness

This control varies the volume of sound emanating from the music system. It is so designed that it will vary both channels at the same time. As the control is turned clockwise, the volume increases.

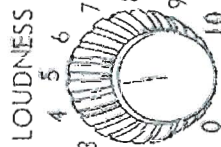

For some music systems using low output cartridges and inefficient loudspeakers it may be necessary to turn the control to the far right for real loudness. With high output cartridges and efficient speakers, the sound may become very loud at low settings of the control. This is not unusual. The actual position of the control is not critical as long as you obtain the range of volume desired.

### Compensator

It is a phenomenon of the human hearing mechanism that when volume is low, the ear is less sensitive to extreme low and high notes. Thus, whenever the system is being operated at a low level, the sound will not seem to be as wide range as it is at higher levels. To compensate for this deficiency, your amplifier incorporates a special circuit which automatically boosts the extreme lows and highs whenever the volume is reduced. To introduce this compensating network into the system, move the slide switch to "Loud." When the sound level is increased, this compensation automatically decreases since it is no longer needed. When the switch is in the "Vol." position the compensation network is inactive.

### COMPENSATOR



### Balancing the System

Whether the system is being used stereophonically or monophonically it is important that the sound from the two speaker systems be of equal volume. They may differ because of room acoustics, differences in speaker efficiencies, differences in output between the two channels of a stereo cartridge, speaker placement, discrepancies between the two channels in the original program material, etc.

Scott's patented stereo balancing system makes it easy to detect and correct any differences in loudness between channels. First, set the volume at full room level. It makes no difference what program material you use to check balance. It can be stereo or mono, FM or phono.

Then turn the Selector to Bal. L. Listen to the overall loudness of the sound coming from the left speaker. Quickly turn to Bal. R.

The volume from the right speaker should be at the same level. Switch back and forth quickly between these two positions to check your findings. If the amplifier is not situated near your usual listening area, have someone else turn the switch while you are in the standard listening location.

If the volume is the same at each position, the system is in balance. If it is not, then it is out of balance and this must be corrected by the following simple methods:

**200 and LK-30 series**—The Loudness control on your amplifier is a clutched control. It is actually two separate controls, one for each channel, locked together by friction. If one channel is louder than the other it is easy to correct this problem. Firmly grasp the knob that controls the channel that was louder in the balancing test. With your other hand, rotate the knob on the softer channel slightly clockwise. Re-check the balance by the method described above. Repeat the procedure until both channels are equal. You can now use the clutched control as a regular volume control. The loudness between channels will be equal over a wide range of rotation.

**222, 200, LK-30, LK-52**—The Balance control on your amplifier is designed to correct for any differences in volume between channels. By rotating the control clockwise, the right channel increases in volume in comparison to the left channel. Rotation counter-clockwise has the opposite effect. By moving the control to its extreme position it is possible to eliminate one channel completely, if desired.

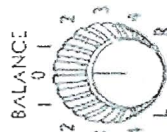

To balance the level, rotate the Selector between Bal. L. and Bal. R. rapidly, and vary the setting of the Balance until the sound from both speakers is equally loud. Unless there are discrepancies introduced by out-of-balance records or stereo broadcasts, the control should not have to be varied frequently.

### Tone Controls

The tone controls used in your amplifier are actually two separate controls (one for each channel) held together by friction. When you turn the treble control, you are changing the high frequencies on both channels. If you desire to modify one channel only, firmly grasp the knob that affects the channel you do NOT want to change. Then turn the other knob as you wish.

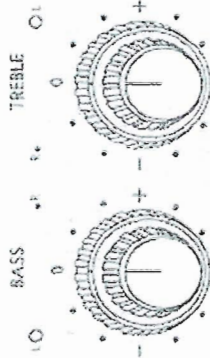

These controls modify the sound to suit the user's taste, the room acoustics, and the program material being used. H. H. Scott provides separate controls for each channel to permit you to adjust for differences between speakers, and differences due to placement of the speakers in the room. The Bass Control modifies the low frequencies while the Treble Control modifies the high notes. Rotating the controls clockwise causes an increase in the amplitude of the frequencies, while rotating counter-clockwise causes a reduction.

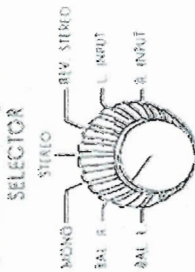

**200 and LK-30 series**—The Loudness control on your amplifier is a clutched control. It is actually two separate controls, one for each channel, locked together by friction. If one channel is louder than the other it is easy to correct this problem. Firmly grasp the knob that controls the channel that was louder in the balancing test. With your other hand, rotate the knob on the softer channel slightly clockwise. Re-check the balance by the method described above. Repeat the procedure until both channels are equal. You can now use the clutched control as a regular volume control. The loudness between channels will be equal over a wide range of rotation.

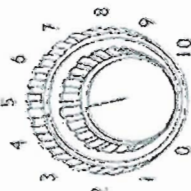

Feel free to use these controls as you see fit. You are the one who must be satisfied with the over-all sound, and the tone controls are the principal way of seeing that you are. However, boosting the treble will accent surface noise on phonograph records and hiss on tapes, while boosting the bass will emphasize record player motor noise.

**MONOSPAN:** By having separate tone controls, Scott makes it possible for you to simulate stereophonic sound on your older monophonic records. Simply turn *up* the Treble control on the *Left* speaker and turn *down* the one for the *Right* speaker. Then turn *up* the Bass control for the *Right* speaker and turn *down* the one for the *Left*. The amount of boost or cut is strictly a matter of taste. You will find that the higher pitched instruments like violins and flutes appear to be coming from the left speaker, while the deeper ones such as drums and cellos appear to be on the right. This will add to your enjoyment of monophonic material.

#### Tape

To listen to the playback of recorded tape, you simply slide the Tape switch to the IN position. In this position it automatically bypasses the Input selector switch and permits you to listen to tape only. When you are finished with the tape, immediately return the switch to the OUT position. Otherwise you will be unable to hear any other program material.



If your tape recorder incorporates a separate playback head (with playback electronics) it is possible to listen to the recording a fraction of a second after it is made as a quality check. Let us assume that a recording is being made from a stereo tuner. The Input selector will be in the Tuner position. With the Tape switch in the OUT position, the system will be playing the actual broadcast.

With the switch moved to IN, the system will now be playing the tape recording of the broadcast just after it has been recorded. By moving the switch back and forth it is possible to hear whether the recording is equivalent to the actual broadcast.

This method will work only for recorders with separate record and playback heads.

#### Scratch

If the surface noise of a phonograph record, or the hiss of the tape recording, or the background noise on a stereo multiplex broadcast becomes objectionable, the Scratch filter is the answer. By sliding the switch to the IN position, most of the high frequency noises will be sharply reduced. If you are listening to especially old 78 RPM records, it may be necessary to turn down the treble controls, too.

#### SCRATCH



#### Rumble

All mechanical devices generate some low frequency noises. Even the finest turntable or tape recorder produces some undesirable sounds. Much of this noise is below the audible range (below 20 cps.) so you may not actually hear it. However, your amplifier is capable of reproducing these objectionable noises and, in doing so it may waste much of its usable power.

Scott engineers have designed a special low frequency sharp cutoff into your amplifier. This circuitry attenuates all sounds below the audible range, insuring that your amplifier will be able to devote all of its power to the audible frequencies.

#### Rumble Filter

(299 and 6K-72 series) — In addition to the standard subsonic sharp cutoff described above, a filter is available to remove annoying

low frequency sounds in the audible range. Generally these are caused by poorly designed record changers or by turntables in need of adjustment. Some phonograph records have rumble recorded right into the grooves. Sliding the Rumble filter to the IN position will greatly reduce these noises. However, some low frequency music will be lost as well.



### Speaker Switch

(222, 229, LK-48, LK-72 series)

This switch is designed to complement the front panel stereo headphone output. When using headphones you may wish to turn

off the loudspeakers to avoid disturbing others in the room. By sliding the Speaker switch to the OFF position, all signals to the speakers will be turned off without affecting the signals to the headphones. In the ON position both headphones and loudspeakers will be operative.



### Phasing the Loudspeakers

A loudspeaker produces sound when the "cone" or diaphragm "pushes" the air in such a manner that our ears detect sound. When two loudspeakers are in operation in a stereo system, it is essential that the cones move back and forth at the same time. If the right cone is moving forward at the same instant that the left cone is moving backward, there will be a noticeable reduction in bass response as well as a poor stereophonic effect.

To be certain that your system is in phase at all times, the following method is suggested:

Tune to a monophonic broadcast with a male voice speaking, or else, play a monophonic record with a male singing voice. Turn the volume to full room level. Stand in front of the two speaker systems and midway between them. Have someone quickly reverse the leads to one speaker. In the correct position, the voice will sound full and appear to be coming from directly between the two speakers. In the wrong position, the voice will lose some of its bass response, and will appear to be coming from both speakers.

If a center channel speaker is used, the same procedure can be employed except that the Selector should be turned to Bal. L. The lead to the center speaker is then reversed until the center and left speakers are in phase. The only time it will be necessary to repeat the phasing operation is if one of the speakers should be disconnected for some reason.

229, 222 series — A phase-reverse switch will be found on the back of the amplifier. Follow the instructions above, except that instead of reversing the leads to one of the speakers you simply slide the phase switch instead. If the switch turns out to be in the reverse position when the system is in phase, reverse the leads to one of the speakers, and return the switch to normal.



### A FINAL WORD

If you have any questions concerning the operation of this instrument, a letter to the following address will bring a prompt, personal reply. TECHNICAL SERVICES DEPT.

H. J. SCOTT, INC.  
111 POWDERMILL ROAD • MAYNARD, MASS.



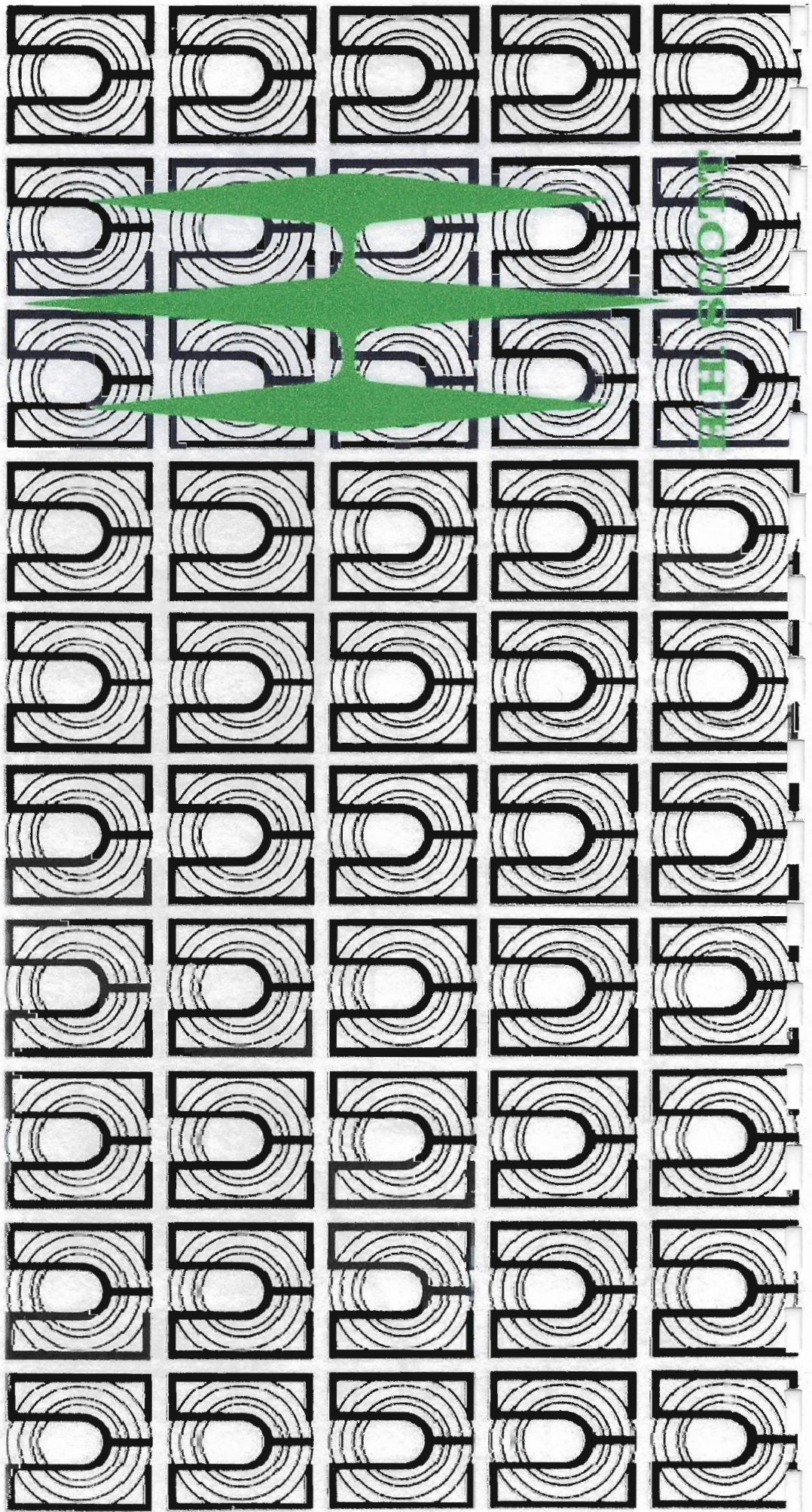



111 Powdermill Road, Maynard, Mass.

SERVICE BULLETIN
For
MODEL 222D STEREO AMPLIFIER

SPECIFICATIONS

- Maximum power output each channel at 1000 cycles: Music waveforms.....24 watts
Steady state.....20 watts
Maximum total harmonic distortion at rated output.....0.8%
Frequency response for 20 watts steady state at less than 1.0%
total distortion.....20 to 20,000 cycles \*
Power bandwidth at rated distortion (IHFM method).....20 to 20,000 cycles \*
Signal for rated output--NAB (NARTB) tape at 1 kc.....3.0 mv.
Signal for rated output--RIAA equalization at 1 kc.....3.0 mv. (MAG LOW)
Signal for rated output--RIAA equalization at 1 kc.....9.0 mv. (MAG HIGH)
Signal for rated output--Ceramic, Tuner, Extra, and Playback.....0.50 volts
Hum and noise.....80 db. below rated power.
Scratch Filter.....Above 5 kc.
Treble boost and Treble cut (at 10 kc.).....15 db. + 2 db.
Bass boost and cut (at 50 cycles).....15 db. + 2 db.

(These characteristics are measured at a line voltage of 117 volts rms and line frequency of 60 cycles per second. No significant changes of characteristics should be experienced for normal variations of line voltages or a line frequency of 50 cycles per second.)

- Input impedance--low level inputs.....Approx. 50 k. ohms
Input impedance--high level inputs.....500 k. ohms
Minimum recommended load resistance on tape outputs.....200 k. ohms
Maximum recommended cable capacitance on tape outputs.....200 mmfds.
Range of line voltage and frequency.....105-125 volts,
50-60 cycles
Power consumption--117 volts at 60 cps (A.C. only).....170 watts

\* All H. H. Scott amplifiers and preamplifiers incorporate a sharp cutoff filter (12 db. or sharper per octave) which becomes fully operative below 20 cycles. This is designed to prevent overload of the output stage and the loudspeaker due to subsonic rumble frequencies and record eccentricity. This means that the full power of the amplifier can be concentrated into the audible range.

GENERAL SERVICE NOTES

1. Check the tubes, particularly those in the power output stage and the rectifier every year. If the tubes are outside the manufacturer's rating or show gas, they should be replaced. Gassy tubes may damage other components of the circuit.
2. When the amplifier is being checked yearly, clean the tubes of dust so that they may radiate their heat more effectively.
3. If, at any time, the hum or noise increases noticeably, check the power tubes. This symptom is often an indication of gassy tubes.
4. If the amplifier blows fuses frequently, check the line voltage. If it rises above 125 volts, drop the line voltage by means of an auto-transformer or place a voltage regulator transformer between the amplifier and the line. If the line voltage is correct, check the amplifier itself. Do not use fuse sizes other than the fuse size specified.
5. Pilot Light Replacement
  - a. Remove tube V102.
  - b. Remove the pilot light assembly by inserting a sharp instrument (a screw driver or knife) between the Control Shield and the Assembly Clip.
  - c. Remove the old bulb and install the new #47 bulb.
  - d. Reinstall the light assembly by snapping it into the hole. Reinstall the tube and tube shield.
6. D. C. Balance Adjustment

To make this adjustment, a short audio cable which has an audio (phono) plug on one end and bare wires on the other is needed. Insert the plug into the Right Channel Tuner input, and connect the two bare wires to the Left Channel speaker terminals (High and 0). Connect a loudspeaker to the Right Channel speaker terminals (High and 0). Connect the Green wire that comes through the plastic grommet to the Right Channel speaker impedance terminal which matches the impedance of the speaker being used. Remove V3 (a 6U8 tube). Set the controls as follows:

Input Selector.....	Tuner
Power Switch.....	Off
Stereo Selector.....	Stereo
Bass and Treble Controls.....	0
Stereo Balance.....	0
Loudness Control.....	0
Compensator.....	Loud
Tape.....	Out
Scratch.....	Out
Speakers.....	On
Equalization.....	Either Position

Insert the line cord into an A.C. outlet and turn the unit on. Wait a few minutes for the amplifier to completely warm up. Slowly turn the Loudness Control clockwise until you can just hear a low hum in the loudspeaker. (If you turn the volume up too high,

the amplifier will oscillate and produce a motorboating noise). Take a small screwdriver and adjust the L Channel balance adjustment control (on top of chassis) for minimum hum. (Hum is a 120 cycle low frequency noise--do not confuse it with any high frequency noises present).

Turn off the amplifier and replace the tube V3. Connect the audio cable to the Right Channel speaker terminals (High and 0) and insert the plug into the Left Channel tuner input. Connect the loudspeaker to the Left Channel speaker terminals (High and 0). Connect the Red wire that comes through the second plastic grommet to the Left Channel speaker impedance terminal that matches the speaker impedance. Remove V103 (the other 6U8 tube). Keep the front panel controls the same. Turn on the unit, and adjust the R Channel balance adjustment control for minimum hum. Turn off the amplifier and replace V103.

#### 7. Bias Adjustment

- a. Set the L and R Bias Adjustment Controls to their extreme counter-clockwise positions.
- b. Connect an audio cable from Bias Test Point L to Channel L Tuner input.
- c. Set the Front Panel controls as follows:

Power Switch.....	Off
Input Selector.....	Tuner
Stereo Selector.....	Stereo
Bass (L & R).....	Extreme counter-clockwise
Treble (L & R).....	Flat (0)
Balance.....	Flat (0)
Loudness.....	0
Equalization.....	Either
Tape.....	Out
Scratch.....	Out
Speakers.....	On
Compensator.....	Vol.

- d. Turn the unit on and turn the Loudness control full clockwise.
- e. Locate the Bias Adjustment Switch on top of the chassis and slide the button back and forth. This will produce a CLICKING sound in the speaker.
- f. Continue to slide the button back and forth causing the click to continue. At the same time, using a small screwdriver, turn the L channel Bias Adjustment control clockwise slowly. The click will become very faint and then begin to increase. Readjust the control to the point where the click is the faintest.
- g. Remove the audio cable from Test Point L and insert the plug into Test Point R.
- h. Repeat the procedure outlined in steps e. and f. but adjust the R channel Bias Adjustment Control.
- i. Because these two controls interact somewhat, you should repeat steps f, g, and h alternately until the faintest amount of clicking is heard.

## INSTRUMENT ALIGNMENT

### Equipment Needed:

Audio Oscillator  
 AC VTVM  
 Oscilloscope  
 Volt-Ohm Meter  
 Load Box  
 Attenuator  
 400 cps Null Filter

### Control Positioning:

Input Selector.....Extra  
 Stereo.....Stereo  
 Tone Controls.....Flat ("0")  
 Loudness Control.....Maximum  
 Stereo Balance....."0"  
 Tape-Monitor Switch.....Out  
 Pickup Switch.....#1  
 Scratch Filter.....Out  
 Compensator.....Loud  
 Speaker Switch.....On

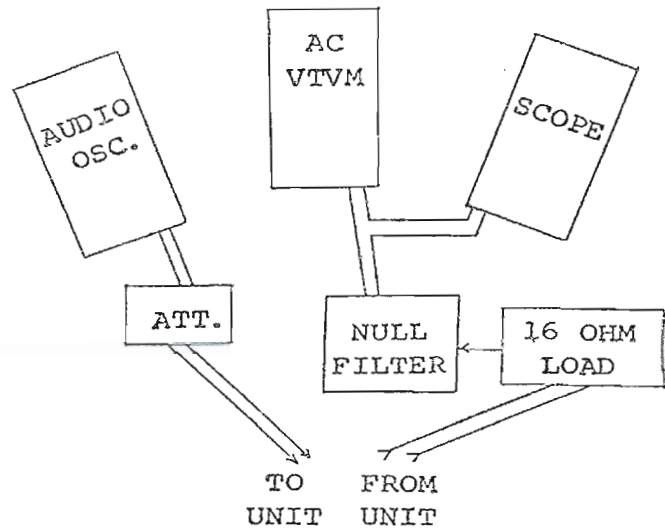

NOTE: Due to variations in tubes, voltages at the plates (pin 6) and screen grids (pin 3) of V3-A and V103-A may have a differential of as much as 30%. Normal is approximately 50v. A 10% variation may be found on all other tubes.

#### 1. Balance Adjustment

(It is suggested that the VOM not be used in this adjustment as there may be too much voltage drop. A 100 to 500 full scale non-switchable milliammeter should be used instead.)

Connect a 16 ohm load to the 16 ohm speaker terminals. Remove both phase splitter tubes and adjust the DC balance pots for minimum meter reading. Do this for both channels. With the phase splitter tubes still removed, set the bias to 44ma (both channels) with the bias pots, measuring from the Cathode Current Test Points on the chassis.

#### 2. Sensitivity Check

Connect the audio oscillator, through the attenuator, into the Left Channel Extra Input Jack. Set the audio oscillator to .4v output at 400 cps. The Output reading on the VTVM should be 18v (20 watts), undistorted. The input voltage of .4v may be adjusted to  $\pm 2$  db to obtain the 18v output. Connect the oscillator to the Tuner input jack and move the Input Selector switch to the Tuner position. You should obtain the same output as in the above.

#### 3. Distortion Check

Using the 400 cps null filter, the distortion must be no greater than 0.6% as read on the VTVM.

#### 4. Tone Control Check

Bass (50 cps)	Treble (10 kc)
Boost 15 db	11 db
Cut 15 db	15 db $\pm 2$ db

Be certain that electrical zero agrees very closely with mechanical zero.

5. Frequency Response Check

With a 0 db reference at 1 kc on the meter, sweep 35 cps and 15 kc. Maximum allowable variation is  $\pm 1$  db. Sweep from 15 kc to 20 kc. Maximum allowable variation is  $\pm 1$  db and  $-2$  db. The low end 3 db down point (from reference) should fall between 17 and 23 cps.

6. Other Front Panel Checks (0db -3 volt scale)

- a. At 5kc, place Scratch filter to "in", note  $3 \pm 1$  db drop.
- b. Turn the front panel Stereo Balance pot to Channel L and note no loss of signal; turn to Channel R and note the complete loss of signal.

7. Pre-Amplifier Gain Check

Turn the controls back to their original settings. Set the oscillator at 1 kc and adjust for 0 db on the 3v scale. Turn the Input Selector switch to RIAA-Phono position. Plug the signal into the Mag Low input and attenuate input 44 db. The output should be "0" db on the 3v scale  $\pm 1$  db. Plug the signal into the Mag High input; the output should be  $-10$  db  $\pm 1.5$  db. Plug into Ceramic input, note additional 26 db loss of signal,  $\pm 2$  db. Return to Mag Low, 0 db 3v scale.

8. Pre-Amplifier Frequency Response Check. (All measurements taken from 0 db Reference Point).

<u>Audio Osc.</u>	<u>Output Change</u>
100kc	0 (REF)
1000cps	$-12$ db $\pm 2$ db
	$\pm 15$

Return the oscillator to 1 kc. Plug signal into the Tape Head input jack and move the Equalization switch to the NAB-Tape position and note a decrease in output voltage of  $3 \pm 1$  db. Set oscillator to 10 kc and note a drop of  $10 \pm 2$  db. Set oscillator to 100 cps and note a rise of 18 db (from 1 kc reference point)  $\pm 2$  db.

9. Repeat Step #3 - Distortion Check

10. Hum Checks

	<u>Selector Switch</u>	<u>Loudness Pot</u>	<u>Max. Hum</u>
a.	Extra	0	3 mv
b.	Extra	10	10 mv
c.	Phono Low	10	35 mv
	Phono High	10	40 mv

11. While checking hum in Channel R, obtain Lissajous pattern on scope and observe phase reversal when phase switch is switched to "reverse" position.

12. Repeat steps 2 through 10 for Channel R. When the unit has met all specifications, seal all necessary pots.

**LEFT CHANNEL**

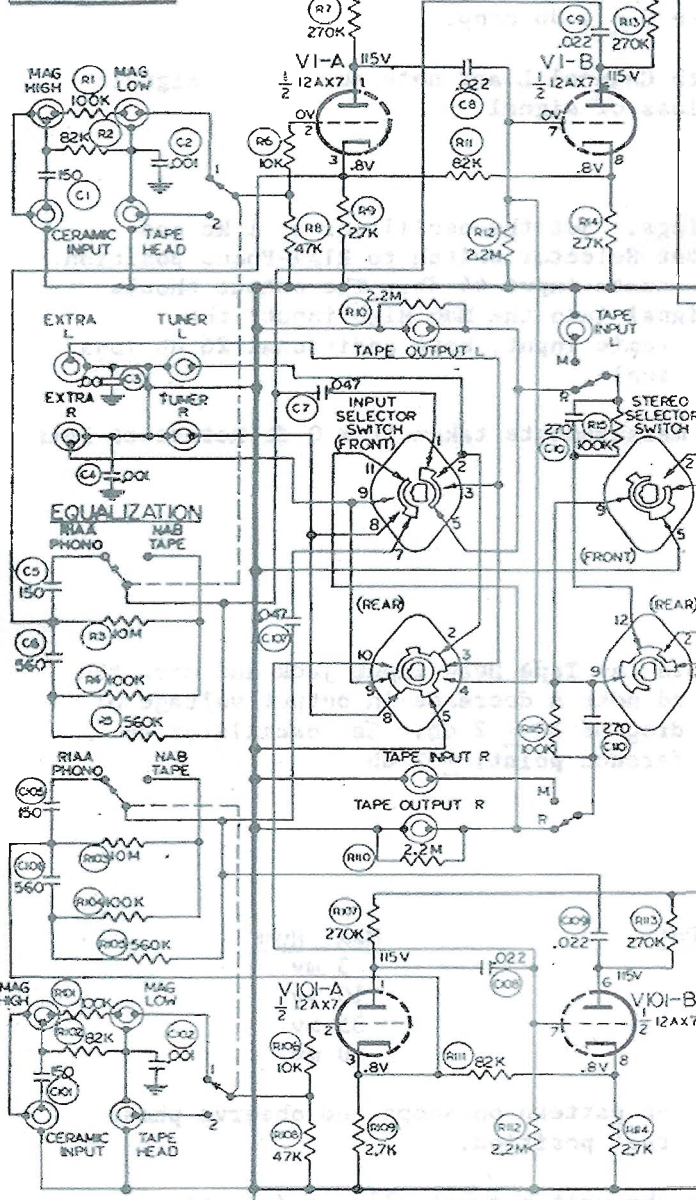

**RIGHT CHANNEL**

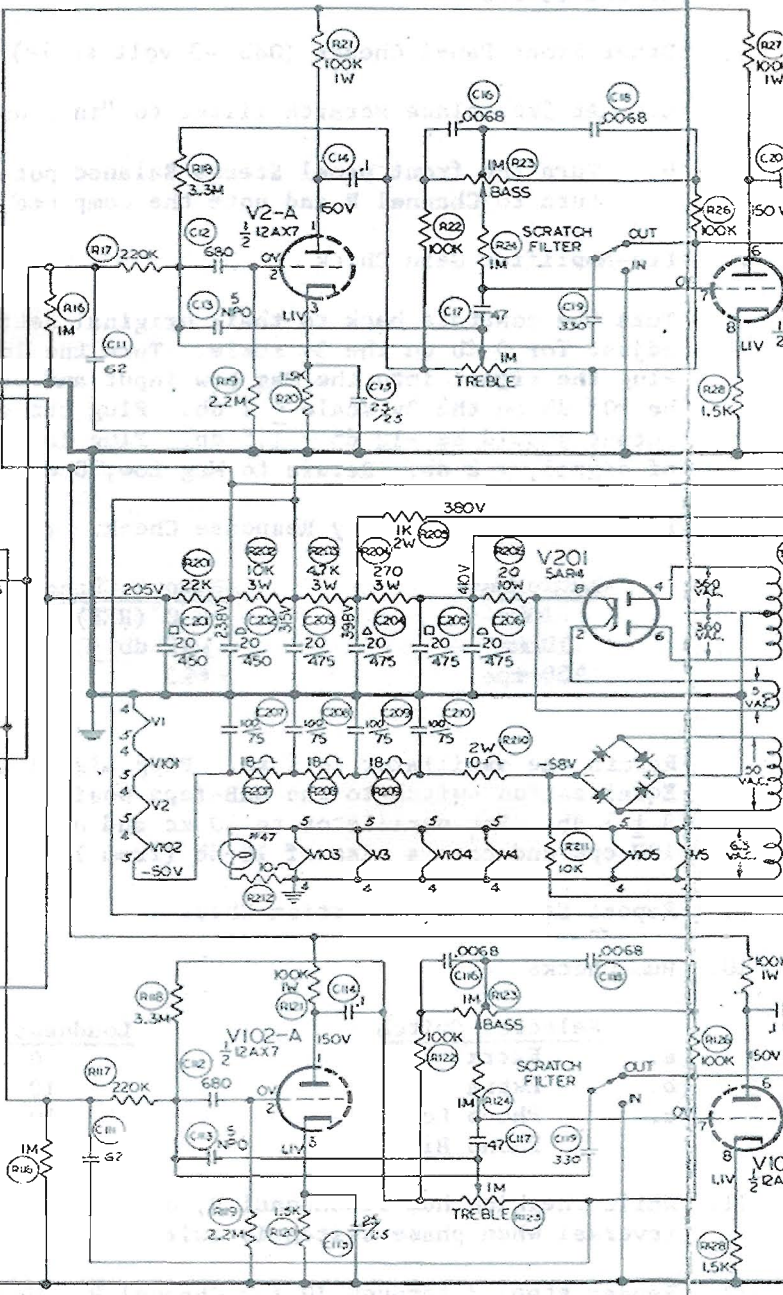

**INPUT SELECTOR SW.**

POSITION	FUNCTION
1	PHONO
2	TUNER
3	EXTRA

**STEREO SELECTOR SW.**

POSITION	FUNCTION
1	BALANCE L
2	BALANCE R
3	MONOPHONIC RECORDS
4	STEREO
5	REVERSE STEREO
6	LEFT INPUT
7	RIGHT INPUT

**EQUALIZATION SW.**

POSITION	FUNCTION
1	RIAA-NARTA-ORTHO
2	NAB TAPE

THE FOLLOWING CONTROLS MECHANICALLY GANGED CONTROLS IN RIGHT CH.

1. INPUT SELECTOR
2. EQUALIZATION
3. SCRATCH FILTER
4. EQUALIZER
5. TUNING
6. SAFELERS SW

REVISIONS:  
 1. REVISION  
 2. REVISION  
 3. REVISION

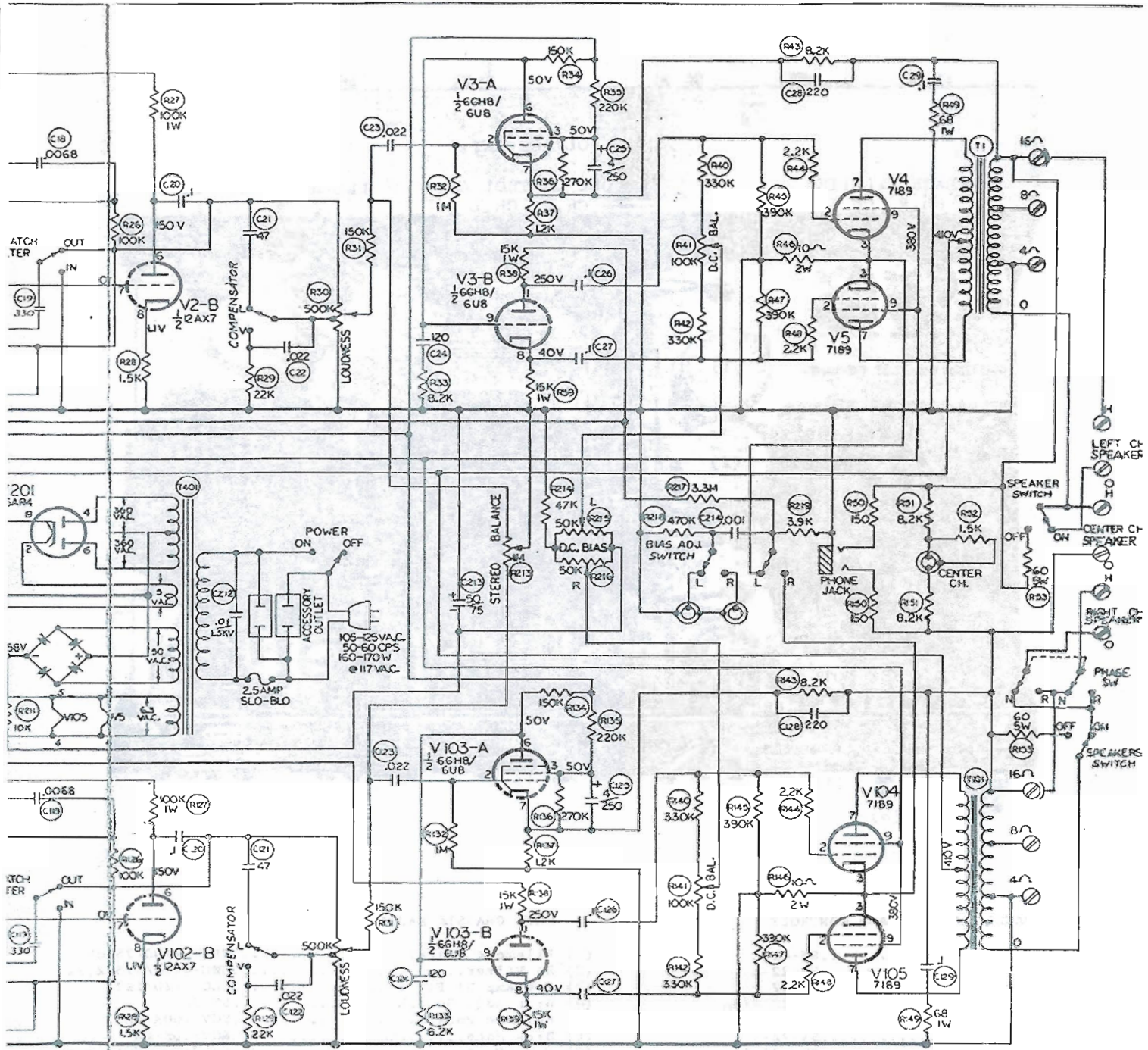

THE FOLLOWING CONTROLS IN LEFT CHANNEL ARE  
 REPRODUCED BY CIRCUIT WITH IDENTICAL  
 CONTROLS IN RIGHT CHANNEL

1. ATTEN SELECTOR
2. COMPENSATOR
3. LOUDNESS
4. STEREO BALANCE
5. LOUDNESS SW
6. SPEAKERS SW

UNITS NUMBERED 208146 TO 208695 USE  
 TRANSFORMER TR12-3-2 AND POWER RESISTOR RWS  
 20-160 (R206). ALL OTHER UNITS USE TRANSFORMER  
 TR12-1-3 AND POWER RESISTOR RWS 10-20.

TYPE 2220 STEREO AMPLIFIER

SCALE: _____		CIRCUIT DIAGRAM		G-1176
H. H. SCOTT, INC. MAYNARD, MASS., U.S.A.				
DR. <i>SP</i>	ENG. <i>WJ</i>	DWG. NO.	2220-C1	548
CH.	PROD. P.C.			

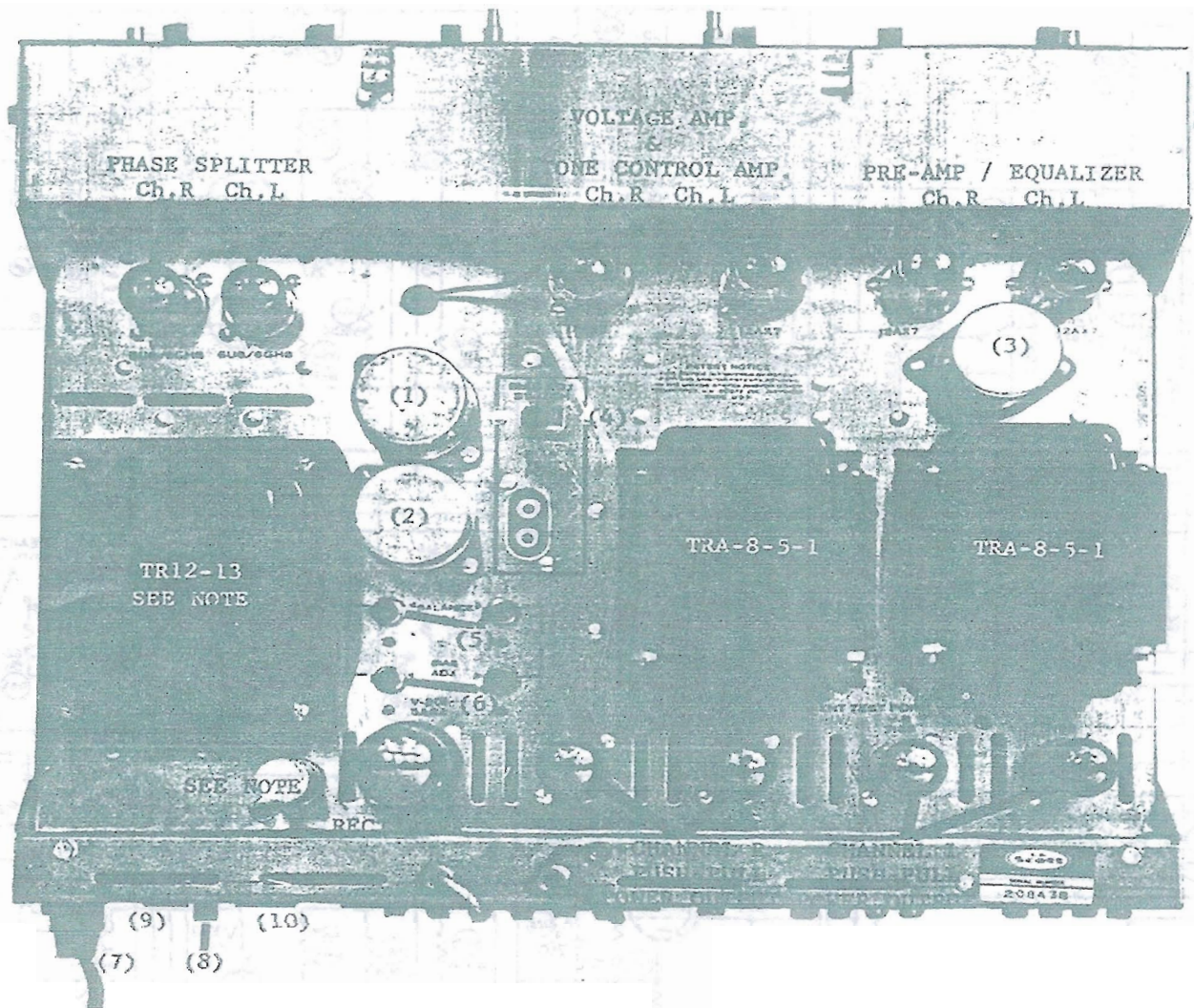

FRONT PANEL SWITCHES AND CONTROLS

Equalization.....	SS-42-2
Tape.....	SS-22-2
Scratch.....	SS-22-2
Speakers.....	SS-22-2/3A
Power.....	SPS-11-2
Compensator.....	SS-22-2
Input.....	SRW-33-6
Selector.....	SRW-27-3
Bass & Treble.....	RCVC-1MT-F
Balance.....	RCV-1MST-3B
Loudness.....	RCVD-500KI-3B
Phones.....	J-3-ST-5
Pilot Light Socket.....	XFL-U4-3
Selenium Rectifier.....	SR-60/200 w/Clip

MAIN CHASSIS MAJOR PARTS AND CONTROLS

(1) Filament Filter.....	CEC-4x100/75 CP
(2) B+ Filter.....	CEC-4x20/475-21/2
(3) Pre-Amp B+ Filter.....	CEC-2x20/2x25
(4) Bias Adj. Switch.....	SS-22
(5) Balance Pots.....	RCV-100K-PH
(6) Bias Pots.....	RCV-50K-PH
(7) Fuse Post.....	XF-3AG w/Nut, Washer
	Fuse.....
	FSB-2.5
(8) Phase Switch.....	SS-22/3A
(9) Switched A.C. Outlet.....	XAC-SA
(10) Unswitched A.C. Outlet.....	XAC-SAR

NOTE: Units with power transformer TR12-3-2 use power resistor RWS 20-160 in place of RWS 10-20 as indicated on schematic.



111 Powdermill Road, Maynard, Mass.

### OPEN, CASE OR CUSTOM MOUNTING H. H. SCOTT COMPONENTS

Due to changes in the required mounting hardware on the various units, the hardware shown on the Mounting Template may be incorrect for your particular set. Be sure to check your set against the pictures on the back of this sheet before ordering hardware.

#### Open Mounting (No Case) for units such as:

- (1) 99 A.B.C.D., 122, 209, 222 A.B.C.; 333, 130, 370, 350, 350-B, 272, 299 A.B.C., 310 A.B.C.D., 314, 330 A.B.C.D., 333, 399, all of the kits except the 1K-150.
- (2) If the amplifier or tuner does not come with the rubber feet already attached, use the Z-P-1, Z-P-5 or Z-P-9 hardware (whichever is supplied). Put the 5/8" sheet metal screws through the feet and screw into the four corners of the set. If the holes have screws already in them, remove the short 1/4" screws and install the 5/8" screws and feet.

#### Case Mounting the Above Units (Wood & Metal):

- (3) Remove the rubber feet if they are attached to the set. Support the case on its rear edge between two books. Slide the component down into the case by holding the back of the component with your left hand and the front with your right. While inserting the instrument, be very careful not to dislodge any tubes. Position the unit so that the four holes in the bottom line up with the four holes in the case. The component is always inserted in the opening away from the grille.
- (4) Using the Z-P-10, 12 or 13 hardware which is supplied with the case, install the longer 1" sheet metal screws in the feet in place of the 5/8" screws. Start the screws into the holes (See Note) DO NOT TIGHTEN. Correctly position the unit in the case and install the rubber spacers between the unit and the case near the screws, where needed, to hold the set in position. Tighten the feet and screws so that they are SNUG, do not overtighten.

NOTE: Units having spacers with a hole in the middle should be installed between the unit and the case before the screws are started into the holes in the set.

#### SEE REVERSE SIDE FOR MOUNTING DETAILS

#### Custom Mounting the Above Units:

- (5) Remove the rubber feet. If the chassis has a hole near each side through both the top and bottom plates, use the Z-P-5 hardware and mount as shown on the Custom Mounting Diagram.
- (6) Remove the rubber feet. If the bottom cover has a hole near each edge, with an internally-mounted threaded fastener, use the Z-P-9 or Z-P-15 hardware (whichever is supplied or required) and mount as shown on the Custom Mounting Diagram.
- (7) Remove the rubber feet. If the bottom cover has a square hole punched out near each edge, use the Z-P-16 or Z-P-17 hardware (whichever is supplied or required) and mount as shown on the Custom Mounting Diagram.

#### Wooden Case Mounting for the:

296, 208, 340, 355, 4310, 4100, etc.

- (8) If the bottom cover has a hole near each edge, install as described in Paragraphs 3 & 5.
- (9) If the bottom cover has a square hole punched out near each edge, install as described in Paragraphs 3 & 7.

#### Metal Case Mounting the Above Units:

- (10) Mount the unit as described in Paragraphs 3 & 4.

#### Custom Mounting the Above Units:

- (11) Mount as described in Paragraphs 6 or 7.

For more information or replacement of misplaced hardware, contact:

H. H. SCOTT, INC.  
111 Powder Mill Road  
Maynard, Massachusetts

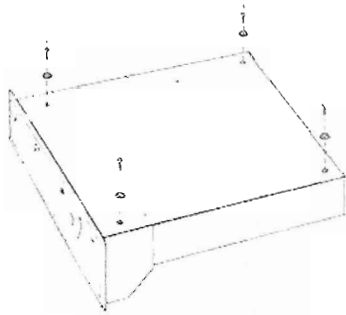

Z-P-1  
(2)

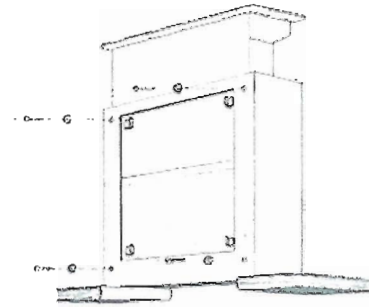

Z-P-10  
(4) & (6)

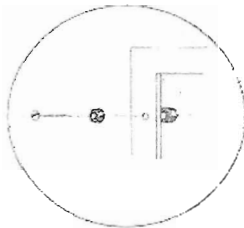

Z-P-13 -NOTE-  
(4) & (10)

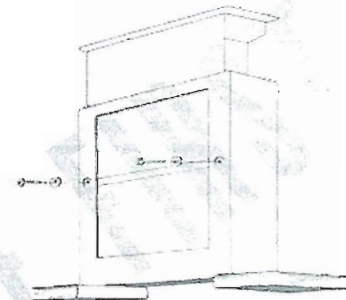

Z-P-15  
(3) & (8)

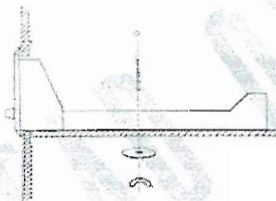

Z-P-5  
(5)

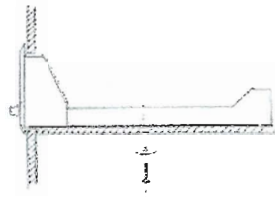

Z-P-9 & 15  
(6) & (8)

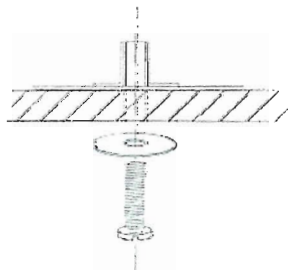

Z-P-9 & 15 Detail

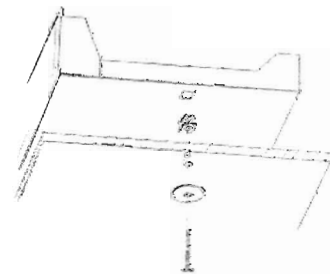

Z-P-16 & 17  
(7), (9), & (11)

(SEE OVER ALSO)

# HOW TO GET THE MOST FROM YOUR AMPLIFIER

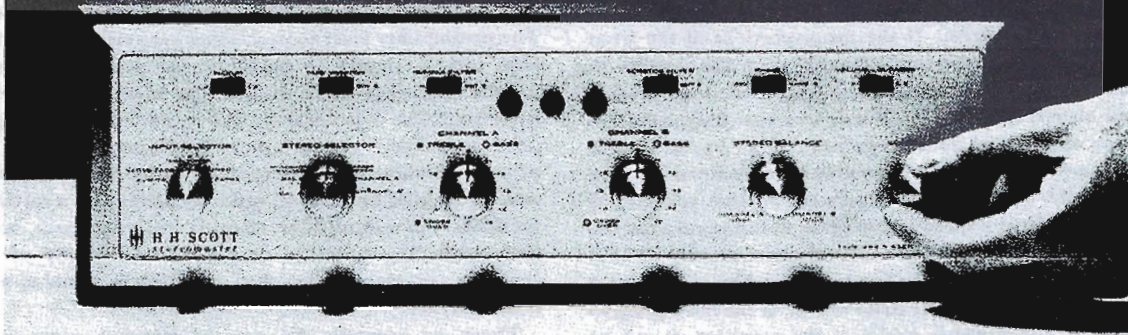

by DANIEL R. von RECKLINGHAUSEN  
Chief Research Engineer, H. H. Scott, Inc.

**W**HAT is the "most" in an amplifier? Is it power, wide frequency response, or long life? Is it low distortion or flexibility of use? It is all of these and more. It is all the qualities that make for the enjoyment of music through high-fidelity reproduction.

How can the maximum performance of any amplifier be obtained? It may sound prosaic, but one of the major causes of inadequate performance can be traced to the user's failure to read the instructions furnished by the manufacturer. Too frequently the owner attempts to connect and operate his new equipment immediately after unpacking it. Only when the performance is considerably less than satisfactory does he finally look at the instruction manual. Years of dissatisfaction can often be avoided by studying the manual.

Another factor that greatly affects an amplifier's performance, both initially and over a period of years is how it is installed. While it is beyond the scope of this article to show how each of the many models of amplifiers can be used to their maximum capability in particular installations, a few methods of installation should be discussed.

One of the simplest types of installation incorporates an integrated amplifier into a bookshelf high-fidelity system. Here it is usual to find that the amplifier is installed in an accessory case and is mounted horizontally. Since high-fidelity amplifiers consume from 60 to 350 watts of electrical power, a considerable amount of heat must be dissipated, and the usual method of heat dissipation is a simple installation is natural convection of air. Thus the amplifier should be set out at least two inches from the wall, and preferably more than four inches of air space should be provided above it. If a tuner is used in the same installa-

tion, the tuner should be placed to the side of the amplifier if there is room for it there. If there is not, then the tuner should be installed below the amplifier, to keep heat from the amplifier from causing the tuner circuits to drift.

The installation of the turntable or record changer is equally important. Because the cartridge may pick up the magnetic hum field radiated from an amplifier's power transformer, amplifier manufacturers try to keep hum radiation as low as possible. However, some magnetic cartridges are sensitive to this magnetic field, and a little experimentation is usually necessary to determine the optimum relative positions of the amplifier and the turntable for minimum hum. As a general rule, the farther the turntable is from the amplifier the less hum radiation will be picked up.

It is, of course, important to have adequate shock mounting for the turntable to reduce mechanical feedback. Similarly, speaker systems should be installed so as to minimize any mechanical feedback between the speakers and the turntable. Small pads of felt or foam rubber under the speaker enclosure usually reduce or eliminate such feedback.

Mechanical feedback from the speaker to the tuner is seldom likely to be very troublesome. Separating the loudspeaker and tuner by a few feet is generally enough to eliminate this kind of difficulty.

Installation problems become more severe if all or part of the equipment is placed in a single cabinet. The general rules outlined above are applicable, of course, but the correction of difficulties will require more effort, mainly because space is generally restricted. If possible, avoid installing amplifiers and tuners in a vertical position. If appearance or space limitations make such placement necessary, it is

important that the units be fastened securely, not just supported by their front panels, unless the manufacturer specifically recommends such a method of installation.

Since the air heated by an amplifier rises, units mounted vertically run considerably warmer than do the units in a normal horizontal installation. This has a tendency to reduce the life of the components, although most manufacturers use components capable of operating at temperatures as high as 185 degrees. If the metal portions of the front panel reach a temperature of more than 120 degrees in normal operation, it is advisable to use fans to provide forced air circulation. While it is true that fans make distracting amounts of noise when running at normal speeds, adequate ventilation can almost always be obtained by using an a.c.-only eight-inch fan operated at low voltage. If the blades turn at a speed of 200-800 rpm instead of a normal 1,500-1,600 rpm they will provide adequate cooling without noise. The speed of the fan can be reduced by connecting a 15- to 50-watt light bulb in series with it. If the fan is plugged into an accessory power outlet of the amplifier, it can be turned off and on with the rest of the equipment. To filter out any mechanical vibration from the fan, it can be installed on shock mountings.

**T**HE WIRING of the system and, in particular, the connections to the amplifier are generally described with sufficient clarity in the instructions provided by the maker. However, the following hints may further improve performance.

In connecting the speaker to the amplifier, particular attention should be paid to the neatness of the connection, particularly when the speaker cable has stranded conductors. It often happens that an individual strand of wire is not twisted among the other strands and creates a short circuit to another amplifier terminal, to a speaker terminal, or to the amplifier chassis, causing distortion, hum, motor boating, or other undesirable effects. The screw terminals on the amplifier and the speaker should be tightened until the connections can withstand the vibration induced by playing the system at high levels.

Cartridges, tuners, tape recorders, and other signal sources are generally connected to the amplifier by shielded cables that terminate in pin plugs. The outside shields of these plugs sometimes fail to make good electrical contact with the amplifier input jacks. All plug connections should be inspected carefully to ensure that proper contact is made.

It frequently happens that these interconnecting cables are not of the exact length required for the installation. Not only are extra lengths of cables unsightly, but when they are just stuffed out of sight at random they can cause serious hum problems. One of the best methods of reducing hum due to wiring is to twist the two shielded cables coming from the pickup about each other very tightly before connecting them to the amplifier. If the cables are longer than necessary, the extra length may be reduced by making a tight little roll of cable as far from the amplifier as practical. A similar method may be used to reduce hum from tuner wiring, tape-recorder wiring, or the wiring from

other program sources. If separate preamplifiers and amplifiers are used, the same twisting-and-rolling procedure should be followed, except that the roll of cable should be located as far from the power amplifier as possible.

But even after proper installation the amplifier is not necessarily ready for optimum service. At this time, the instruction manual should be consulted so that the amplifier controls may be set to their correct operating positions. The preamplifier level control, sometimes called the pickup level control, should be turned to the position suggested for the particular make of cartridge used in the system. Some amplifiers may not have such a control, employing instead a number of phono inputs of differing sensitivity. Instructions indicating the proper input for a given type of cartridge should be followed carefully, because if a cartridge overloads the preamplifier circuits, distortion will occur. Only when the cartridge output and sensitivity of the amplifier are properly matched is optimum signal-to-noise ratio obtained.

These are generally the only adjustments necessary to ready an integrated amplifier for operation. Assuming that the speaker has average efficiency and that the room is of average size, normal listening level should be obtained with the loudness control turned up about halfway. As for the tone controls, the user should not be afraid to use them. There is no rule that tone controls must be set flat at all times, and there is no rule that the "normal" speaker adjustment is optimum in all installations. The sound of a high-fidelity system can vary greatly according to a number of factors, not the least significant of which are the char-

*Cooling a vertically mounted amplifier with a fan slowed by a series-connected light bulb. To permit air flow, the cabinet must stand off slightly from the wall.*

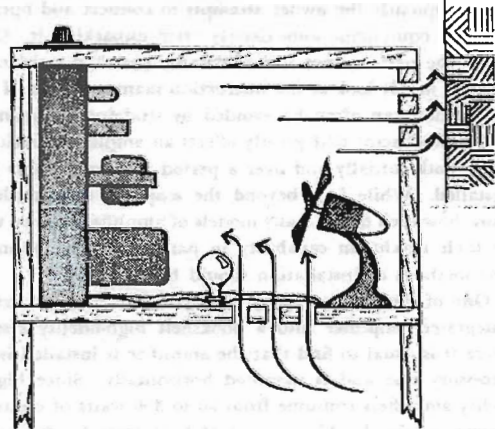

acteristics of the listener's ear, the acoustical characteristics of the listening room, the placement and characteristics of the speaker, and the characteristics of the pickup and of the recording being played. The tone, balance, loudness, and speaker controls should be adjusted to yield the most pleasing sound. Ideal sound is generally considered to be sound that approaches what is heard in a good hall.

The optimum control settings for one recording are not

necessarily the same for others. Some highly critical listeners may prefer to select different tone-control settings for each recording and perhaps even for different sections of the same recording. Some listeners have developed the habit of noting their control settings for each disc on the record jacket, so that they, or other members of the family, can reset the tone controls for each record without having to experiment.

Most high-fidelity tuners and tape recorders also have output level controls. Some also have multiple output jacks that provide different output voltages. The level controls of these units should be set so that the loudness of the sound remains the same when the input selector of the amplifier is switched from "phono" to "tuner" or "tape recorder." If the amplifier or preamplifier has separate level controls for each of these inputs, it is generally best to keep the tuner or tape-recorder level controls near the maximum settings. The amplifier or preamplifier input level controls should then be adjusted to give the same volume from each input.

In most installations, the stereo-balance control can be kept near its center setting when listening to records. If considerable readjustment is required when listening to stereo broadcasts, it is then desirable to adjust the output level controls on the tuner (or multiplex adaptor, if used) until the same stereo-balance setting can be used either for stereo broadcasts or for records.

If the system contains a separate preamplifier and power amplifier, the level controls on the power amplifier should also be adjusted. As a first approximation, the controls should be set to give normal listening volume when the loudness control on the preamplifier is at approximately one half of its maximum setting. A more precise adjustment can be made by listening with loudness compensation and turning the loudness control from approximately ten o'clock (low listening level) to two o'clock (loud listening level) and noting the quality of the sound. If there is too much bass at the low setting, the level controls on the power amplifier are set too high. If there is too little bass at the low setting of the loudness control, the level controls on the power amplifier are set too low. The correct settings can be found quickly with a little experimentation.

In no case should the system produce a normal listening level when the loudness control is just barely turned up. This may give the owner a feeling of having lots of reserve power available, but actually the power rating of the equipment remains unchanged. Furthermore, it is practically impossible to obtain perfect stereo balance and tracking at very low settings.

**I**F THE amplifier is installed and adjusted properly, long and trouble-free service can be expected. Still, nothing in this world is perfect, and difficulties may occur at one time or another. By no means all of these will be the fault of the amplifier itself. Not infrequently the wiring or control settings are disturbed by children, pets, or visitors. It is advisable to keep a sketch of the wiring connections and control settings with the manufacturer's instructions, so that

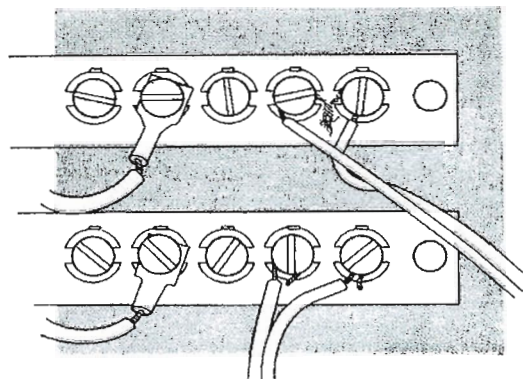

*Touching wires at speaker terminals, in upper strip, short out the signal. Lower strip shows neat, trouble-free connection.*

the proper state of things can be quickly restored.

If it is not possible to correct a trouble by checking connections and control settings, the manufacturer's instructions may give servicing hints. The parts most subject to aging are tubes, and a few basic rules apply to their replacement. Never pull out a tube with the equipment turned on. This may cause additional damage. Replacement tubes must be of the identical type supplied in the original equipment, and preferably they should be of the same brand. Unless the manufacturer has given specific approval, no other tube type should be substituted, regardless of any claims that may be made for a certain type of tube. A great deal of trouble can be avoided by following this simple rule.

The only sure way to determine whether or not a tube is defective is to replace it by another one, noting any change in performance. Without technical training, it is generally not possible to spot defective tubes, other than those that have been broken. Even though a tube does not light up, it may be that another tube within the amplifier is at fault. It is a good safety measure to keep a set of spare tubes at home, along with spare fuses, in case of breakdown.

In cases where neither replacing tubes nor following the manufacturer's servicing instructions cures the malfunction, a competent service man (preferably from the manufacturer's authorized repair service) should be called in. If, after consultation with the manufacturer, it is found necessary to return the unit to the factory for service, the equipment must be packed properly and insured for its full value. The original shipping carton with all its filler material always makes the best shipping container. If you no longer have the original shipping carton, be sure the equipment is packed securely enough to withstand rough handling, including being dropped.

A high-fidelity system is like a fine car: its maximum performance can be obtained only when it is treated properly and when the manufacturer's instructions as to maintenance are followed. If questions come up, it is wise to assume nothing. Never hesitate to call on the manufacturer of the equipment for advice. Any reputable company will be pleased to provide you with all possible assistance.

## **H. H. SCOTT . . . a history of leadership in the Acoustic field**

To insure that every H. H. Scott component meets the highest standards of quality, H. H. Scott maintains this ultra modern plant for the design and manufacture of all its components.

This new plant, located in Maynard, Massachusetts, includes a machine shop, sheet metal facilities, coil and transformer department, electrical assembly department and fully equipped laboratories for design and research.

The engineering department is staffed by 12 graduate engineers who are primarily concerned with developing new and better components for high fidelity sound.

Every high fidelity component receives over 50 electrical and mechanical tests before it leaves the factory. Special electrically shielded "screen rooms" are used for aligning I-M tuners. There are life test facilities where components are run for thousands of hours under strict controls to test their durability.

These extensive investments in facilities back up H. H. Scott's philosophy that there will never be any compromise with quality.

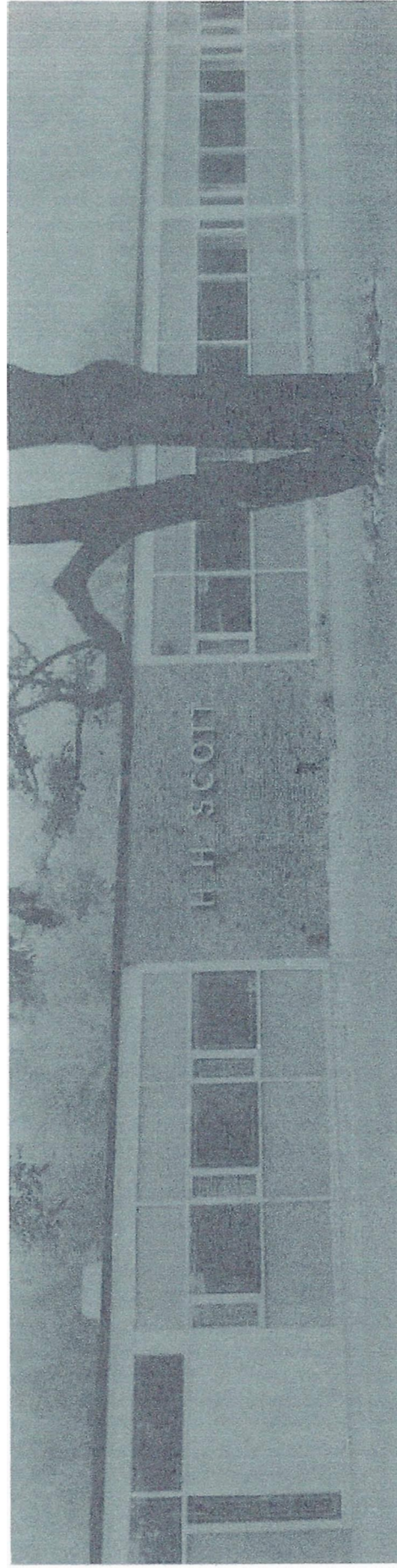



Hermon is a Fellow of the IRE, the Acoustical Society of America (25 years), and the AES. He is a former Chairman of the Boston Chapter of the IRE, former member of the Board of Editors of the IRE, and various committees of the American Standards Association on sound instrument. In the early 50's he received the John Potts Medal from the AES for outstanding contributions to audio. At present, he is President of the AES and Chairman of the Board of the IHFM. He is listed in "Who's Who in America," "Who's Who in Engineering," "American Men of Science," "Who's Who in Commerce and Industry." He is a member of the MIT Alumni Council, and it makes you wonder when he gets time to sleep (if he does).

At any rate, Hermon Scott went into business for himself in 1946, which business was incorporated in 1947 as Hermon Hosmer Scott, Inc., which was

later shortened to H. H. Scott, Inc. His original intention was to manufacture a new type of sound-level meter and various other laboratory instruments and equipment for the broadcasting field including a professional model of the dynamic noise suppressor. This, in fact, was used to broadcast the first music disc jockey program, Paul Whiteman's program. At any rate, Hermon decided that as a favor to the engineers who were customers for laboratory instruments, he would make a home model of the noise suppressor, and, since it was used for reproducing music, a noise suppressor with an amplifier. The interesting thing is that this amplifier, the 210-A, proved to be the first commercial high-fidelity amplifier by modern standards.

The company introduced the first so-called "flat" amplifier styling: the 99-A in the early 50's. This design took high-fidelity equipment out of the hobby room or cellar and right into the living room. Also, they introduced the first commercially acceptable wideband FM tuner in 1954. It took the multiplex approval in 1961 to really prove the value of this approach.

Last, but far from least, Hermon Scott is also an author. He has contributed innumerable articles to most important technical magazines, and magazines in the audio field, and he has contributed chapters on noise and sound measurement and analysis to important texts such as the "Noise Handbook" edited by Cyril Harris of Columbia University.