

Garrard

Service Manual for Garrard 6-000 Series



Model 6-300

Automatic Record Changers

(Models in the 6-100, 6-200, 6-300 Series and other Models in the Garrard 'Unimech' and 'Reverse Unimech' Range)

Garrard
Sales Service Department
Kembrey Street
Swindon Wiltshire England
Telephone: Swindon (0793) 693471
Telex: 44271

In U.S.A. :
Plessey Consumer Products,
Garrard Dealer Sales Division,
100 Commercial Street,
Plainview, New York 11803.
Telephone: (516) 938 8900

Contents

| | page |
|--------------------------------------|------|
| Index | |
| General Information | 3 |
| Installation | 4 |
| Installation Adjustments | 5 |
| Wiring | 6 |
| Fitting Pickup Cartridge | 7 |
| Adjustments | 8 |
| Operating Instructions | 9 |
| Parts Lists and Exploded View | 10 |
| Maintenance | 16 |
| Dismantling | 17 |
| Fault Charts | 18 |

Diagrams

| | |
|--|------------|
| Transit Screw Assembly | Diagram 1 |
| Spring Mounting Location | Diagram 2 |
| Model 6-300 Installation Adjustments ... | Diagram 3 |
| Models 6-100/6-200 Installation Adjustments | Diagram 4 |
| Power Supply Connector | Diagram 5 |
| Voltage Changeover Connections | Diagram 6 |
| Pickup Tag Strip Connections | Diagram 7 |
| Pickup Phono Socket Connections | Diagram 8 |
| Single-Hole Fixing Cartridge | Diagram 9 |
| Two-Hole Fixing Cartridge | Diagram 10 |
| Rear of Pickup Arm, Raised, Model 6-300 | Diagram 11 |
| Rear of Pickup Arm, Raised, Models 6-100/6-200 | Diagram 12 |
| Model 6-300, General View | Diagram 13 |
| Model 6-300, Turntable Removed | Diagram 14 |
| Model 6-300, Sub Plate Mechanism | Diagram 15 |
| Model 6-300, Underside View, 2-pole Motor | Diagram 16 |
| Model 6-300, Underside View, 4-pole Motor | Diagram 17 |
| Intermediate Wheel Height Adjustment ... | Diagram 18 |

General Information

Garrard Model 6-300 record changer features Garrard 'Unimech' mechanism developed from the Garrard Model CC10 compact record changer. This unit plays up to eight records pre-selected for 10-78, 7-45, 7-33 or 12-33 (size and speed) according to the size of the pickup cartridge fitted.

The unit also plays single records manually (using fluid damped cueing if desired) or automatically to the above settings, and rejects records or allows single record repeat when desired. Switch-off is automatic at the end of a single record or the last of a stack, with the pickup automatically returning to its rest. A short record spindle is supplied with the unit for single record play and a single play adaptor for large hole records is available as an optional extra, as is large spindle F45 for playing a stack of large hole records.

The standard Model 6-300 is driven by a 2-pole induction motor operating on 110/125 volts, 60Hz or 220/240 volts, 50Hz power supply according to its specification. A special two range motor operating on 115/130 volts or 220/240 volts, 50Hz is also available. Some units have the Garrard 4-pole motor or the Synchro-Lab motor fitted.

Model 6-300 accepts the Garrard range of clip-in pickup cartridges, but a bracket in the pickup head permits single hole fixing cartridges to be fitted. Normally a wide pickup head is used to accommodate two hole fixing cartridges, but a narrow head for single hole fixing only is fitted to some units.

Before connecting the unit, make sure that the power supply is as shown on the motor. If the pickup circuit of the unit is connected to an amplifier whose wiring is not isolated from the power supply, isolating components must be incorporated in the pickup circuit, otherwise the pickup circuit can become live. Always disconnect the power supply and protect the stylus before servicing a unit.

Garrard record playing equipment is made to play records complying with B.S. 1928/1965 and I.E.C. Publication 98, also other similar standards.

If you require spare parts, please quote the code number for the Garrard unit, unless a full description can be given. The code number for Model 6-300 is 76070 plus its following three figure stroke number over stamped on its inspection label attached to the underside of the unit.

Garrard 'Unimech' Models

The Model 6-300 mechanism forms the basis for a series of Garrard units. The common feature of this series is that the auto mechanism is assembled on a sub-plate. There are a number of varieties of trims and finishes for Model 6-300 (and its single player version, Model 6-300P) and the unit is similar to Models 6-100 and 6-200 except that the latter units are not fitted with cueing mechanism or bias compensator. Model 6-100 is distinguished from Model 6-200 by its smaller (8in) turntable. Reference to Model 6-300 in this manual also applies to the other models in the series unless otherwise stated.

Since the original three units in this series, Garrard have introduced a number of variants based on this mechanism, notably:

Model 6-200C is similar to Model 6-300 but has no bias compensator and its cueing mechanism is not viscous fluid damped.

Model 6-200CP is a single record player version of Model 6-200. The mechanism allows auto play of a single record, but there is no record stacking facility and the unit is equipped with non-fluid damped cueing.

Model 6-100C is similar to Model 6-300 but has the smaller (8in.) turntable, no bias compensator and non-fluid damped cueing.

Model 6-100T is a special battery motor version of Model 6-100 with tubular pickup arm of the Garrard Model CC10A type.

Model 42 is similar to Model 6-300. When fitted with a magnetic cartridge it is known as Model 42M, with a ceramic cartridge, Model 42C.

Model 63SP is a 'Unimech' single record player allowing auto play. It has Model 6-300 damped cueing, a bias compensator and a more sophisticated pickup arm than the former unit. Usually it is supplied with mounting base, cover and connecting leads, as a Garrard Module.

Model 440 is the top-range model in the 'Unimech' series. Functionally it is similar to Model 6-300 but has a more sophisticated bias compensator and pickup arm, the arm being fitted with a slide-in cartridge carrier. Fitted with a magnetic cartridge it is known as Model 440M, with a ceramic cartridge it is called Model 440C.

Garrard 'Reverse Unimech' Models

Garrard 'Reverse Unimech' models have the sub-plate mechanism as 'Unimech' models, but are distinguished by a record support side platform instead of a record overarm. The record side support is made possible by turning the record spindle through 180° (reversing it). This enables the record spindle release pawl to draw the edge of a record away from its side support when loaded on the platform. The 'Unimech' release lever unit is replaced by a different release lever and inter-release lever unit on 'Reverse Unimech' models and the turntable spindle housing also turned through 180° to operate the record release pawl as described. Otherwise the mechanism functions as with 'Unimech' models.

Model 6-400 is the 'Reverse Unimech' equivalent of Model 6-300. It has the side platform record support, as explained, also a different type bias compensator from Model 6-300.

Model 62 This model is up-graded from Model 6-400 by its pickup arm which has a non-adjustable counterbalance weight and a slide-in cartridge carrier.

Model 70 also has an up-graded pickup arm including a transparent housing around the pickup base. Besides its counterbalance weight it has additional pickup arm counter-weighting beneath the unit and is fitted with a Synchro Lab motor.

Model 770 is the top-range 'Reverse Unimech' model with Model 70 features, excepting counter-weighting beneath the unit. Additionally it has a dual-calibrated bias compensator.

Exploded view service sheet supplements are available for the models briefly described here in this basic service manual.

Installation

Cabinet Space

(Not 63SP or 'Reverse Unimechs', except Model 6-400)

The size of these units is 13 $\frac{1}{4}$ " (336.5mm) wide by 11 $\frac{1}{4}$ " (298.5mm) front to rear by 2 $\frac{3}{8}$ " (55.5mm) below lower edge of unit plate with a 2-pole or a 4-pole motor fitted or 2 $\frac{3}{4}$ " (58mm) with an unscreened Synchro-Lab motor. Height above the lower edge of the unit plate is 3 $\frac{3}{4}$ " (101mm) with the overarm fully lifted.

If cabinet space is at a premium beneath the unit, it can pay to measure clearances, as over most of the underside area, cabinet space requirements will be less than the figure given above. (The 2 $\frac{3}{8}$ " (55.5mm) figure usually is for overarm spindle clearance.) Allow for the following points, however.

Provide clearance of $\frac{1}{2}$ " (12mm) to the dimensions stated in order to give $\frac{1}{4}$ " (6mm) all round the edge of the unit and $\frac{1}{2}$ " (12mm) above and below for the unit to float freely on its mountings and be clamped for transit. Additional clearance may be required around the unit according to the design of the cabinet or case. If necessary, allow clearance for operating the controls, record handling, removal of the record spindle and for 12" records.

Unpacking

When unpacking a unit, withdraw it and its polyfoam pack from the carton as instructed on the carton flap (if a single-pack carton). Never lift a unit by its pickup arm or overarm. Carefully remove all packing materials, which may include wire ties, rubber bands, plastic bags and cardboard fitments. Accessories are found in the cavities of the polyfoam pack.

Fitting

1. Drill and cut out the mounting board to the template. (Fix the template to the board with adhesive tape and mark through with a sharp point.) Board thickness

should be no greater than $\frac{1}{8}$ " (9.5mm).

Note that Garrard composite template, part number 77234, gives installation information for any of the models mentioned on page 3. These models may also be fitted to the Garrard type B10 base (cover optional extra) or the Garrard B15 base (H15 cover for changers, L15 cover for players). In North America these models may be fitted to the type BDC5 combination base and dust cover.

2. Attach power supply, earth and audio leads, checking that they do not restrict the movement of the mechanism (see wiring section).
3. Assemble the unit to the board, with transit screws turned right down and locking clips set vertical (as Diagram 1a). Locate mounting springs in their recesses as in Diagram 2. Make sure any attached leads go through the cutout.
4. When the unit is in place, press it down on its springs, then turn the transit screw locking clips horizontal. See Diagram 1c. (Note: during transportation the transit screws should always be turned counterclockwise to clamp the unit against the board as in Diagram 1b.)
5. Before fitting an automatic record spindle, with the arm clipped to its rest, rotate the turntable clockwise by hand until it spins freely, to make sure the mechanism is not in cycle.
6. Insert the record spindle in the turntable centre, rotate it until its location is felt, then press down firmly so that it is secured by the turntable retaining clip.
7. Reset pickup arm adjustments if necessary (see Adjustments section).

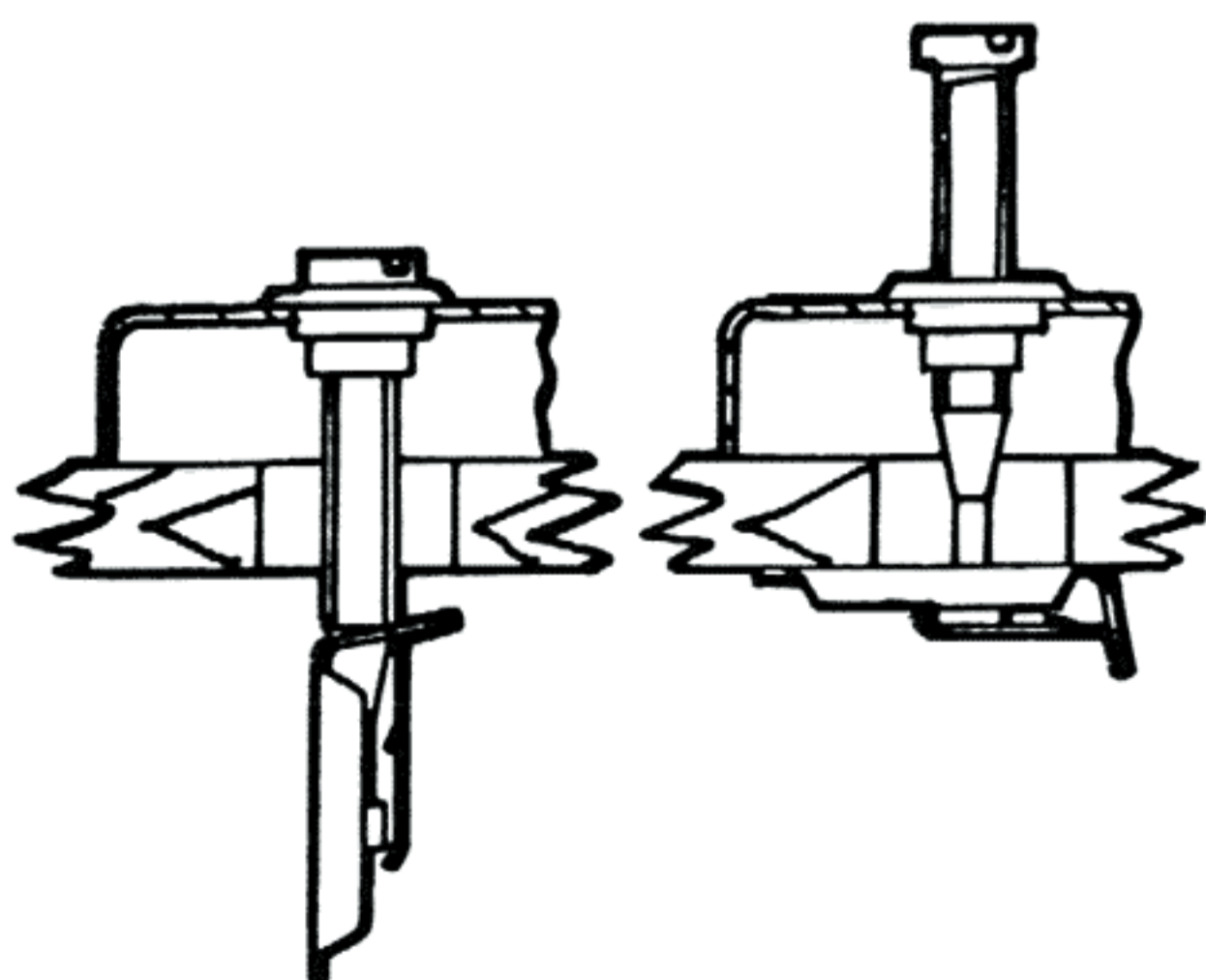

Transit Screws in aligning position

Transit Screws in transport position

Diagram 1a

Diagram 1b

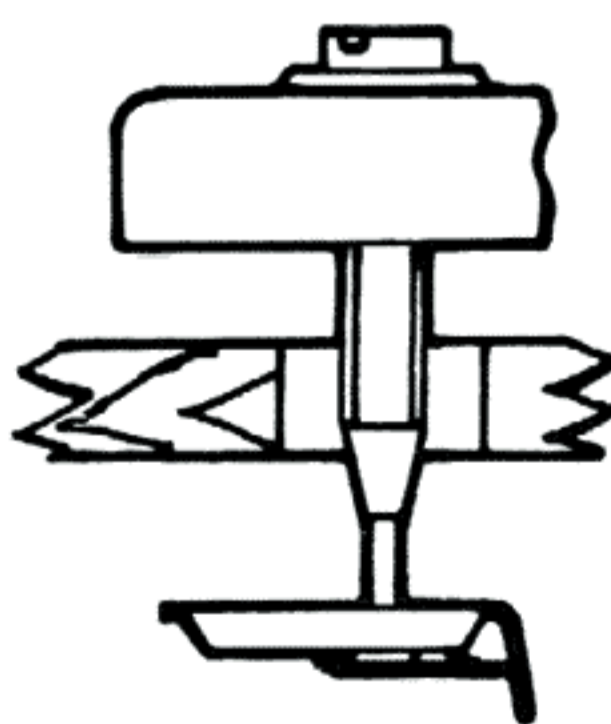

Transit Screws in playing position

Diagram 1c



Spring Mounting location

Diagram 2

Installation Adjustments

(Different for 63SP and 'Reverse Unimechs', except Model 6-400)

Adjustments are factory set and normally should require no attention. However when installing a unit (or of course if a pickup cartridge has just been fitted) the stylus force should be checked or reset, and on Model 6-300 the bias compensator setting also checked.

Stylus Force

Turn the stylus force adjustment screw beneath the pickup arm clockwise to decrease, or counterclockwise to increase force. Diagram 3 shows part of Model 6-300 pickup arm. Diagram 4 shows Models 6-100 and 6-200. Note that the recommended minimum stylus force for these units is 2½ grams. Instructions supplied with the cartridge will tell you the stylus force recommended for the particular pickup cartridge, which should be set using a stylus force gauge. If the adjustment mentioned is not possible because the weight of the cartridge comes outside the range of adjustments,

then the anchorage of the stylus force spring, beneath the pickup arm area shown in Diagrams 3 and 4 can be moved to a different location hole, in order to bring the spring tension within the desired range of stylus force. The position of the counterbalance weight on these units is not adjustable.

Bias Compensator (Model 6300 only)

Turn the bias compensator adjustment button shown in Diagram 3 to line up with the figure on the scale which corresponds to the number of grams stylus force previously set.

The bias compensator (or anti-skating device) compensates for the slight force tending to move the pickup towards the centre of a record. This force is inherent in all pickup arms pivoted in the conventional manner.

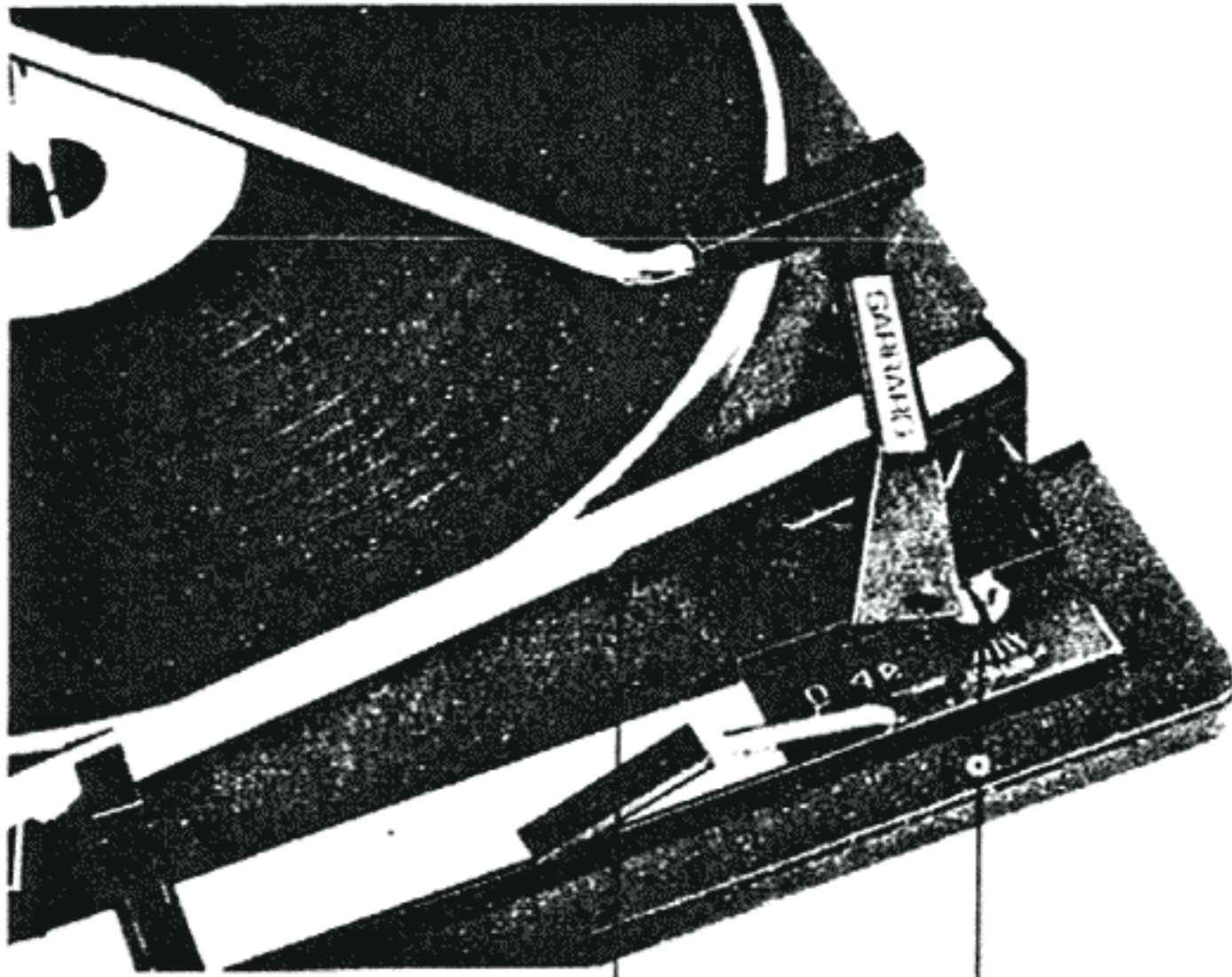

Stylus Force Adjustment Screw beneath Arm (see also screw 'A' in Diagram 11)

Bias Compensator Adjustment Button (see also 'B' in Diagram 11)

Diagram 3

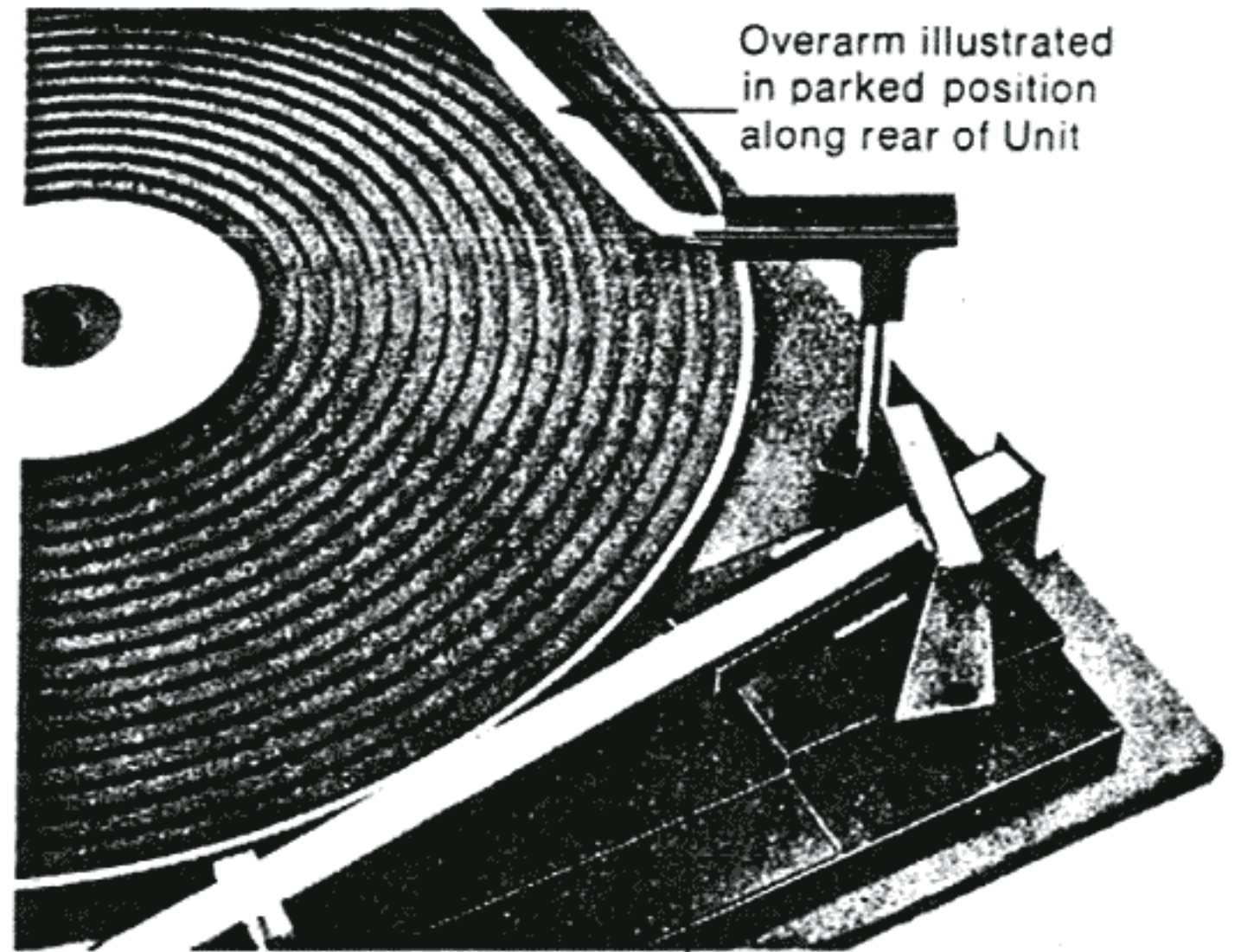

Stylus force adjustment screw beneath Arm (see also screw 'C' in Diagram 12)

Diagram 4

Wiring

Power Supply Connections

Connect an earth lead to the earth tag on the motor mounting plate or the earth screw (unless an earth lead is included in the power supply connector plug and socket).

The other end of the earth lead should be connected to a reliable earthing point.

Connect a power supply lead from the unit to the power supply. Some units are supplied to manufacturers with 'flying' motor leads, while other units may have a power supply connector socket incorporated with the switch (see Diagram 5). These units can be supplied for 110/125 volt 60 Hz or 220/240 volt 50 Hz power supply. A special motor is available which operates on either 115/130 volts or 220/240 volts 50 Hz, according to the way in which one of the plug-in bobbin leads is connected (see Diagram 6). Make sure the voltage details labelled on the motor suit the power supply.

Audio Connections

Connect screened leads to the pickup terminal tag-strip (see Diagram 7) and the amplifier. If the unit is connected to an

amplifier whose wiring is not isolated from the power supply, isolating components must be incorporated in its pickup circuit.

On some units pickup leads terminate at a phono socket instead of a tag-strip but the same pickup lead colour coding applies, namely:

- Red — Right Channel Signal
- Green — Right Channel Ground
- White — Left Channel Signal
- Black or Blue — Left Channel Ground

On units to which a phono socket is fitted, connect phono leads to left and right channel sockets. See Diagram 8.

When the unit is set-up to use with CD-4 quadraphonic equipment, use a pair of Garrard phono leads coded grey and black (not grey and brown) for left and right channels respectively, to ensure suitable lead impedance.

When a stereo pickup is used with a mono amplifier, parallel the right and left channels. (Solder one short-circuiting wire link between the same tags on the phono socket or tag-strip as the red and white leads and another between the same tags as the green and black leads. Then connect either channel to the amplifier input socket.)

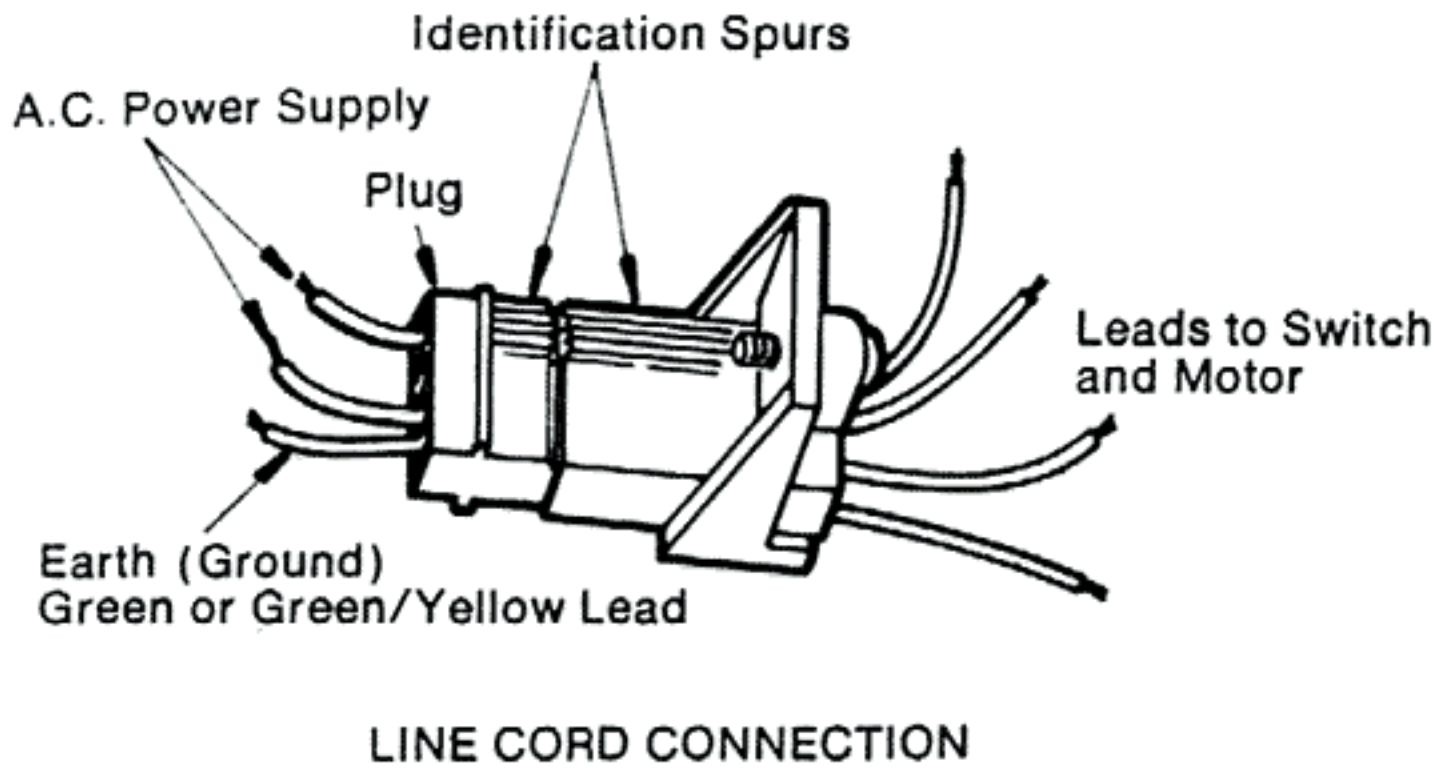

Diagram 5

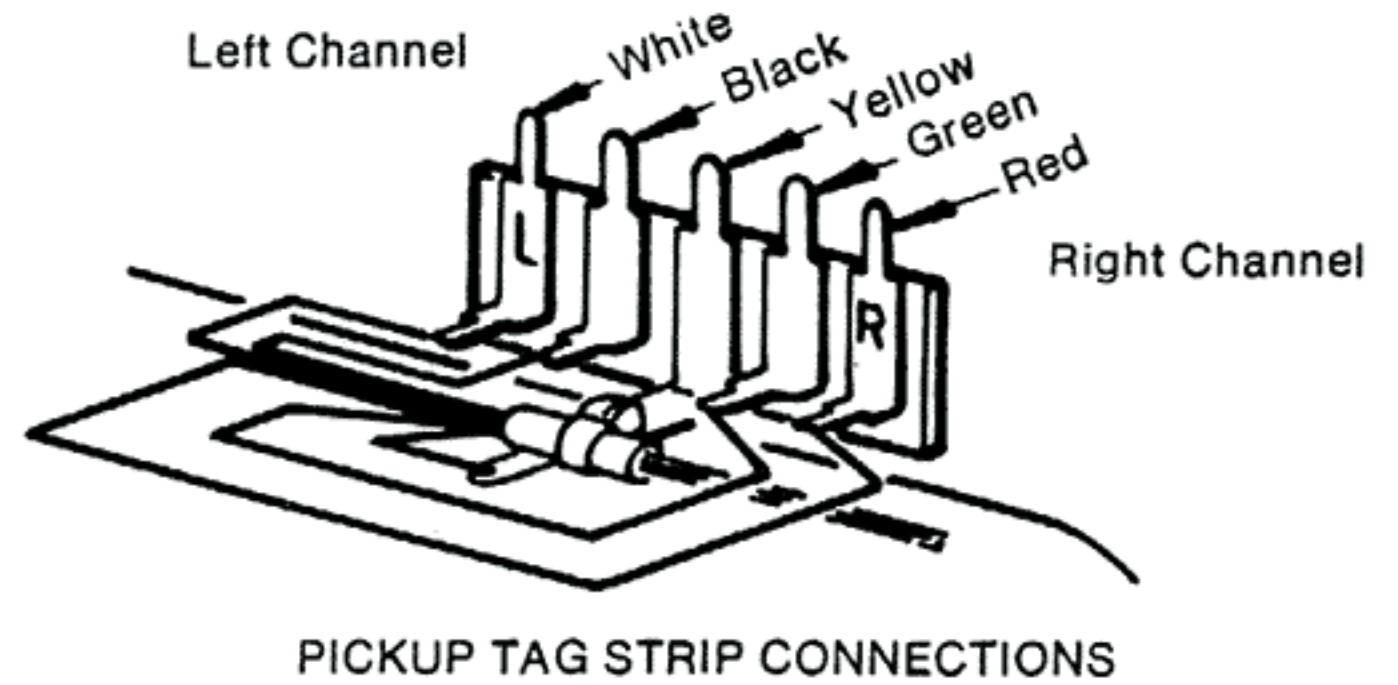

Diagram 7

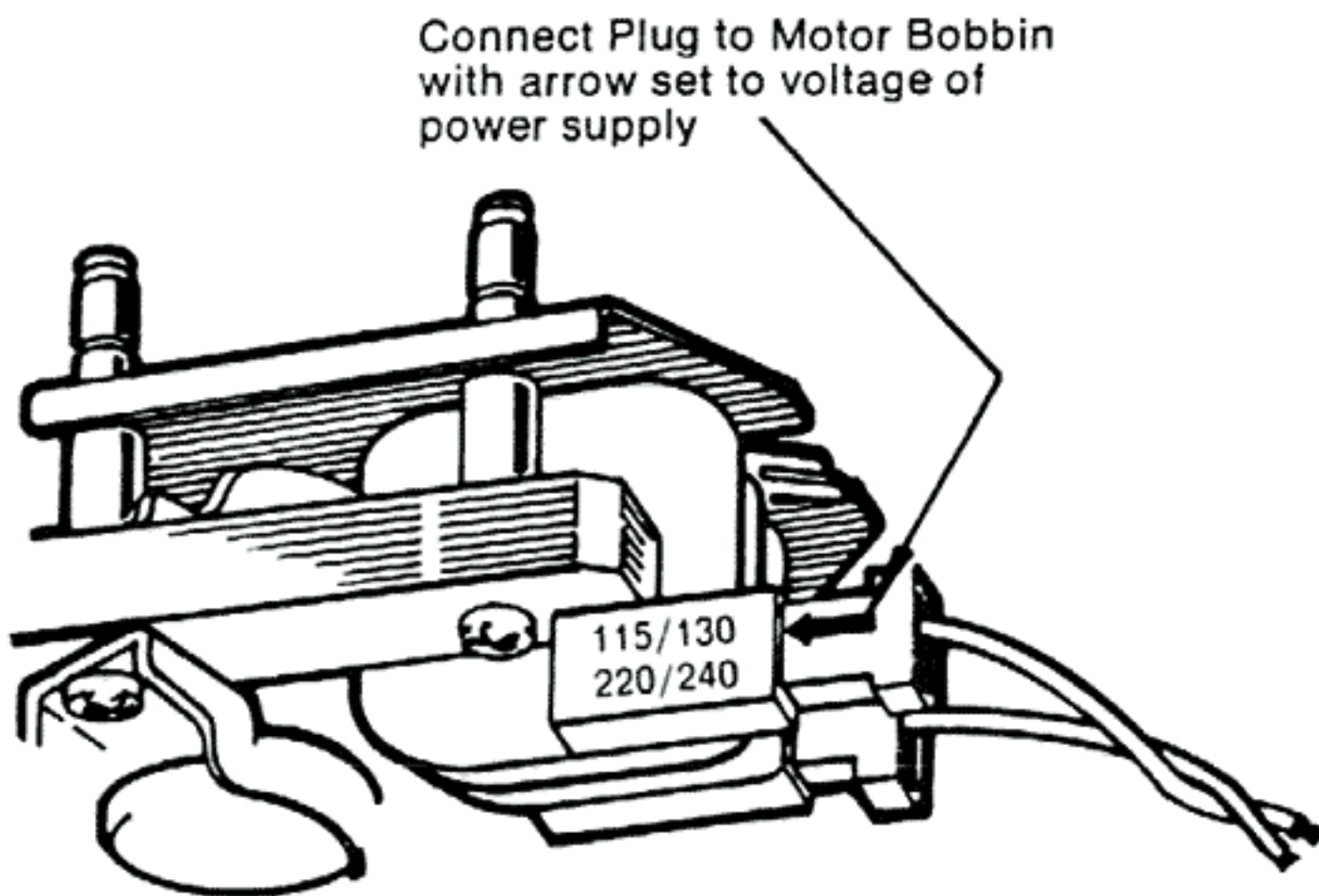

Diagram 6

PHONO SOCKET CONNECTIONS

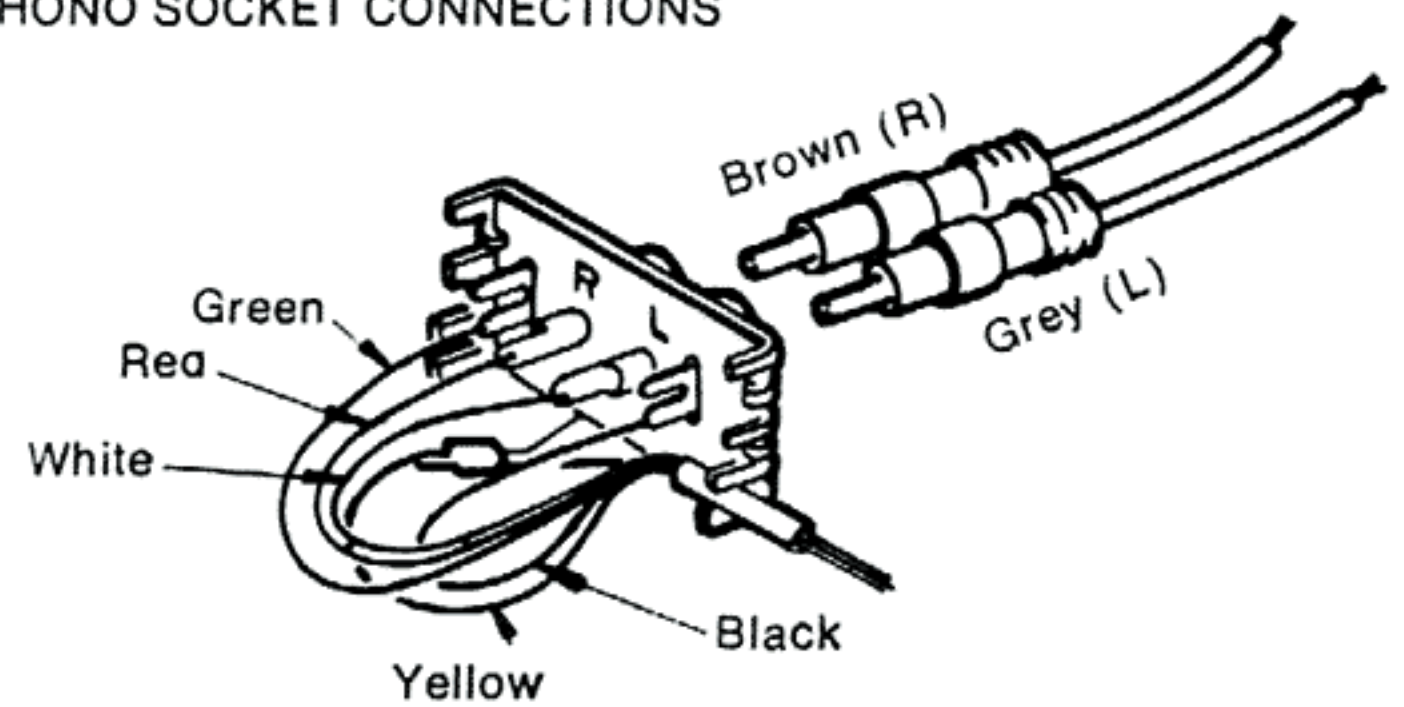

Diagram 8

Fitting Pickup Cartridge

(Similar assembly sequence when slide-in cartridge carrier available).

When a cartridge is to be fitted, information on its connection is usually supplied with the chosen cartridge. These models are designed to accept the Garrard range of clip-in cartridges as standard by the use of a special clip-in bracket which allows most types of single hole, central fixing cartridges to be fitted. Such cartridges are normally fitted to versions of these units which have a narrow pickup shell fitted. Diagram 9 illustrates a typical single-hole fixing cartridge assembly to this type of shell.

A wider pickup shell (accepting a $\frac{1}{4}$ " wide bracket) is needed to accommodate cartridges with a 2-hole ($\frac{1}{2}$ " centre distance) fixing arrangement. Diagram 10 illustrates typical cartridge assembly of the 2-hole type to the wide pickup shell version of the units. The hardware required to fit most

cartridges is provided in Garrard pickup hardware kit, Part No. 59048, special variations must be used for certain cartridges.

The pickup lead colour coding given under 'Audio Connections' applies when connecting a cartridge. Never solder leads directly, as this may damage cartridge elements.

For cartridges having three connections, use the green lead as the common connection or join the green and black leads together and use these as the common connection.

For mono cartridges, use the red and green leads. Insulate and tuck away any leads not required and reset pickup arm adjustments, if necessary, after fitting a pickup cartridge.

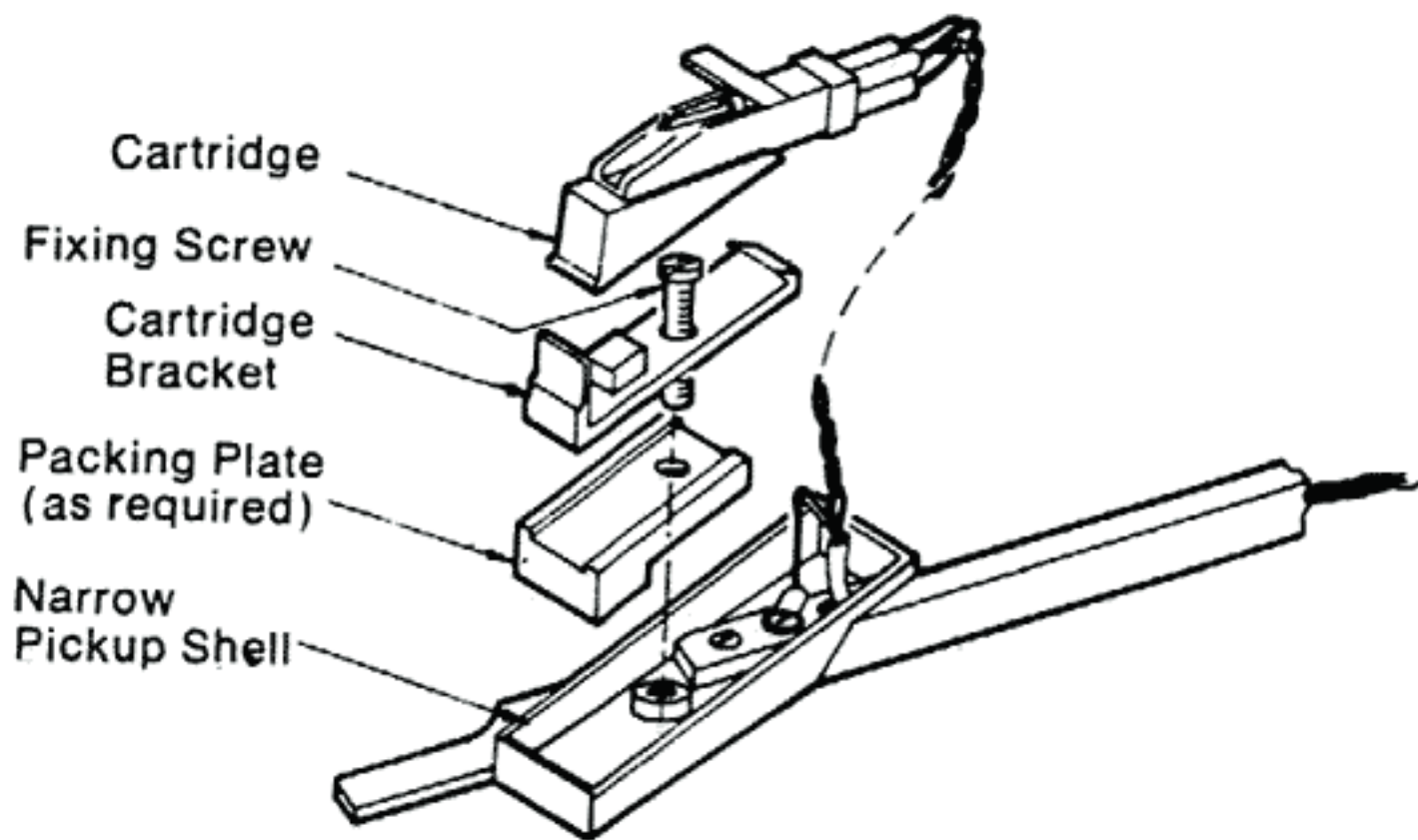

Diagram 9

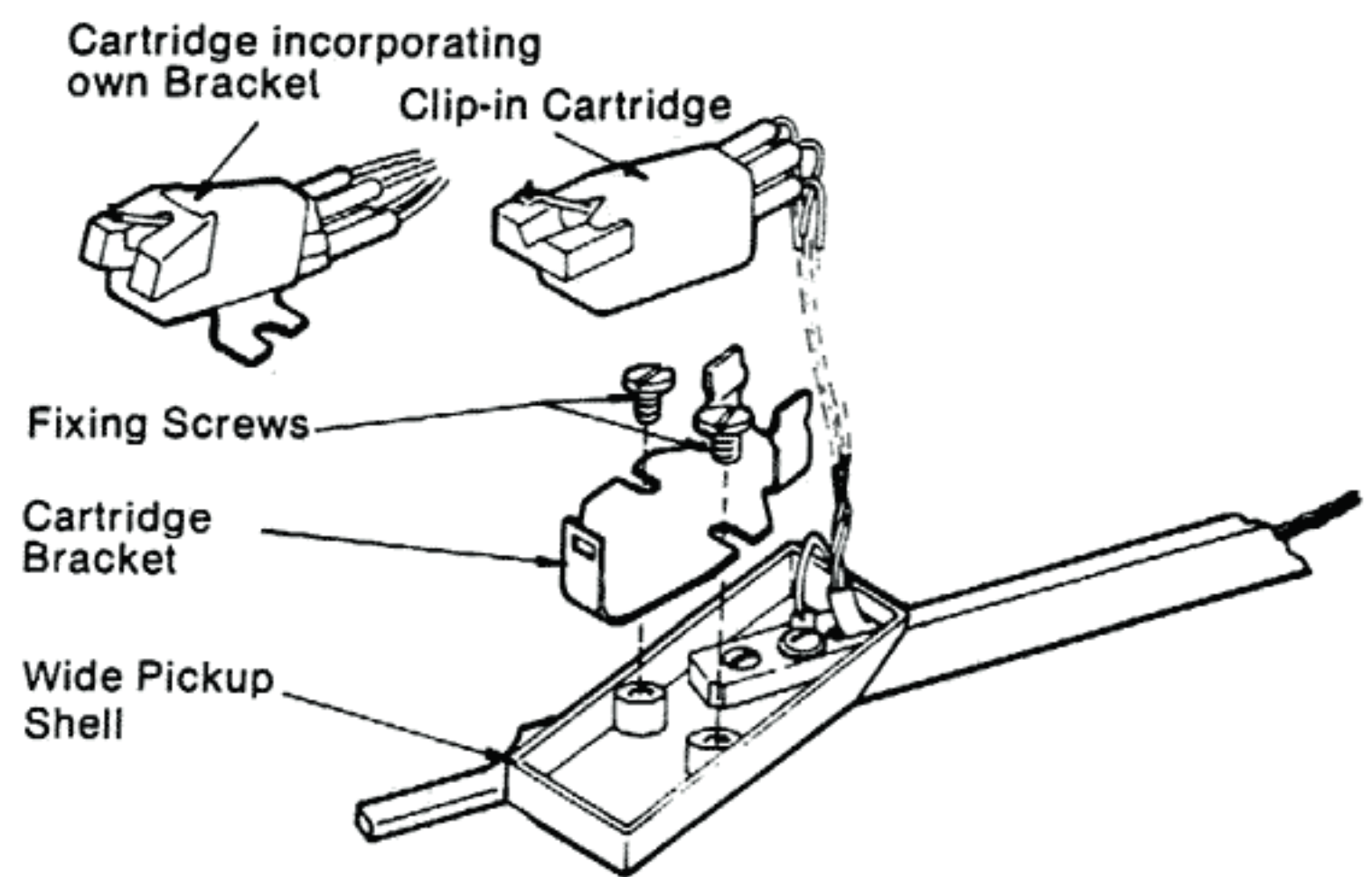

Diagram 10

Adjustments

(Different on 63SP and 'Reverse Unimechs', excepting Model 6-400)

When a unit is installed or if a pickup cartridge is to be newly fitted or changed, it may be necessary to check or adjust the pickup arm settings. Before making adjustments, disconnect the power supply and protect the pickup stylus. If necessary operate the controls and rotate the turntable clockwise by hand to actuate the cycling mechanism.

Pickup Lift Adjustment

This adjustment controls the height to which the pickup lifts on automatic play and normally there should be no more than $\frac{1}{4}$ in between the stylus tip and the top of one record on the turntable as the pickup returns to its rest.

This normal setting applies to a cartridge of about $\frac{3}{8}$ in depth between the stylus tip and the top of the pickup shell. When an extra deep cartridge is fitted the setting may need to be adjusted so that the pickup clears the underside of a record on the record spindle step, and not so many records will be able to be played in automatic sequence. Turn nut (E) in Diagram 11 clockwise to decrease or counterclockwise to increase pickup height. (Nut 'B' in diagram 12.)

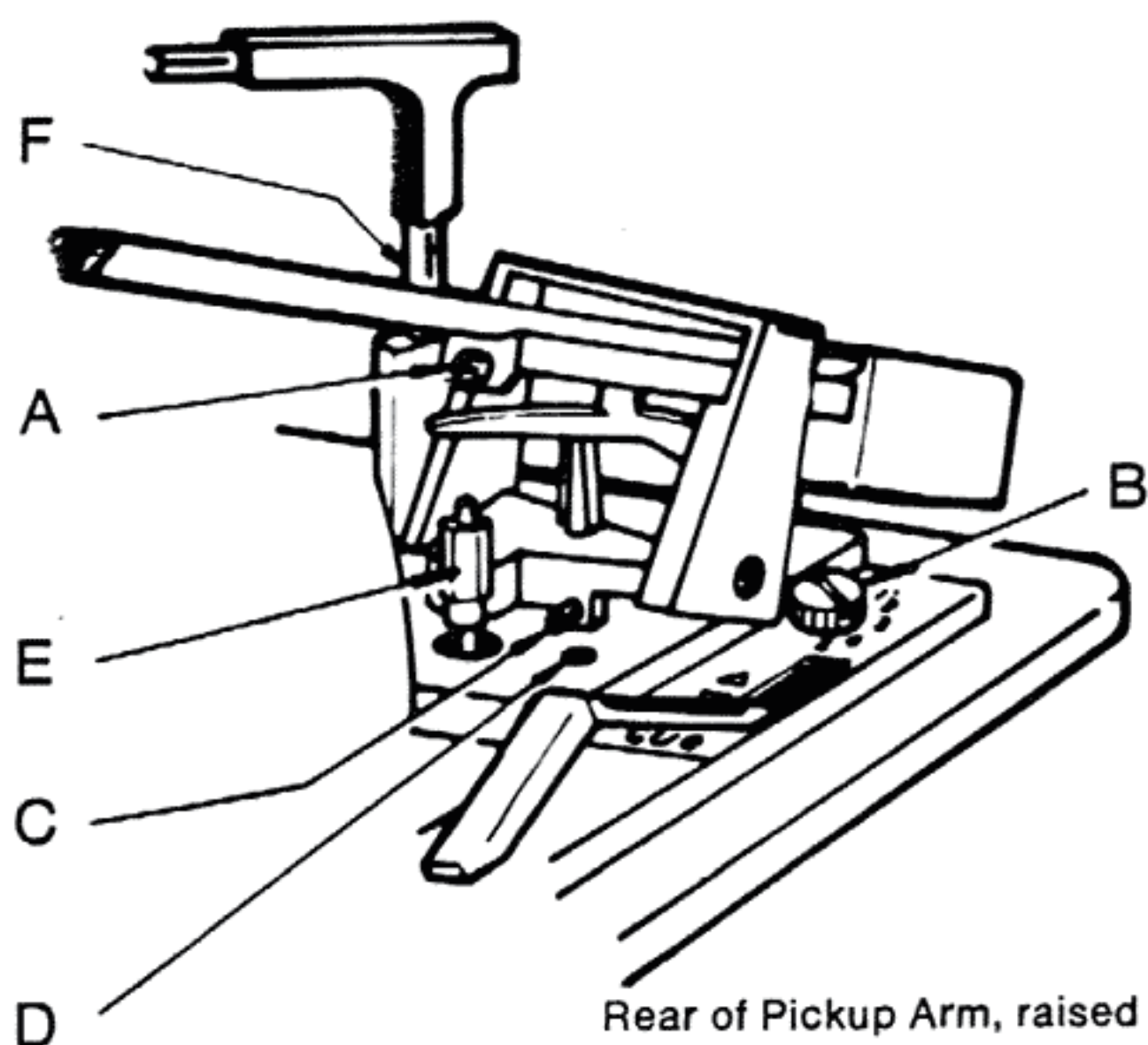

Diagram 11

Pickup Lowering Position

This adjustment governs the radius at which the pickup lowers on to a record when on automatic play, also the correct positioning of the pickup over its rest. If adjustment is necessary — such as to prevent the pickup from lowering on to the top of the slope of the groove guard on the edge of some records — then make the adjustment when the stylus is just above the record surface.

Turn screw (C) in Diagram 11 clockwise to move the pickup arm inwards or counterclockwise to move it outwards. (Screw 'A' in Diagram 12.)

Pickup Cueing Height Adjustment

(not Models 6-200 and 6-100)

The height the pickup is raised depends on how much the cue and pause control is lifted, but with the control fully lifted, this height must not be greater than when the pickup lifts automatically. If necessary turn screw (D) in Diagram 11 clockwise to increase pickup cueing height, counterclockwise to decrease.

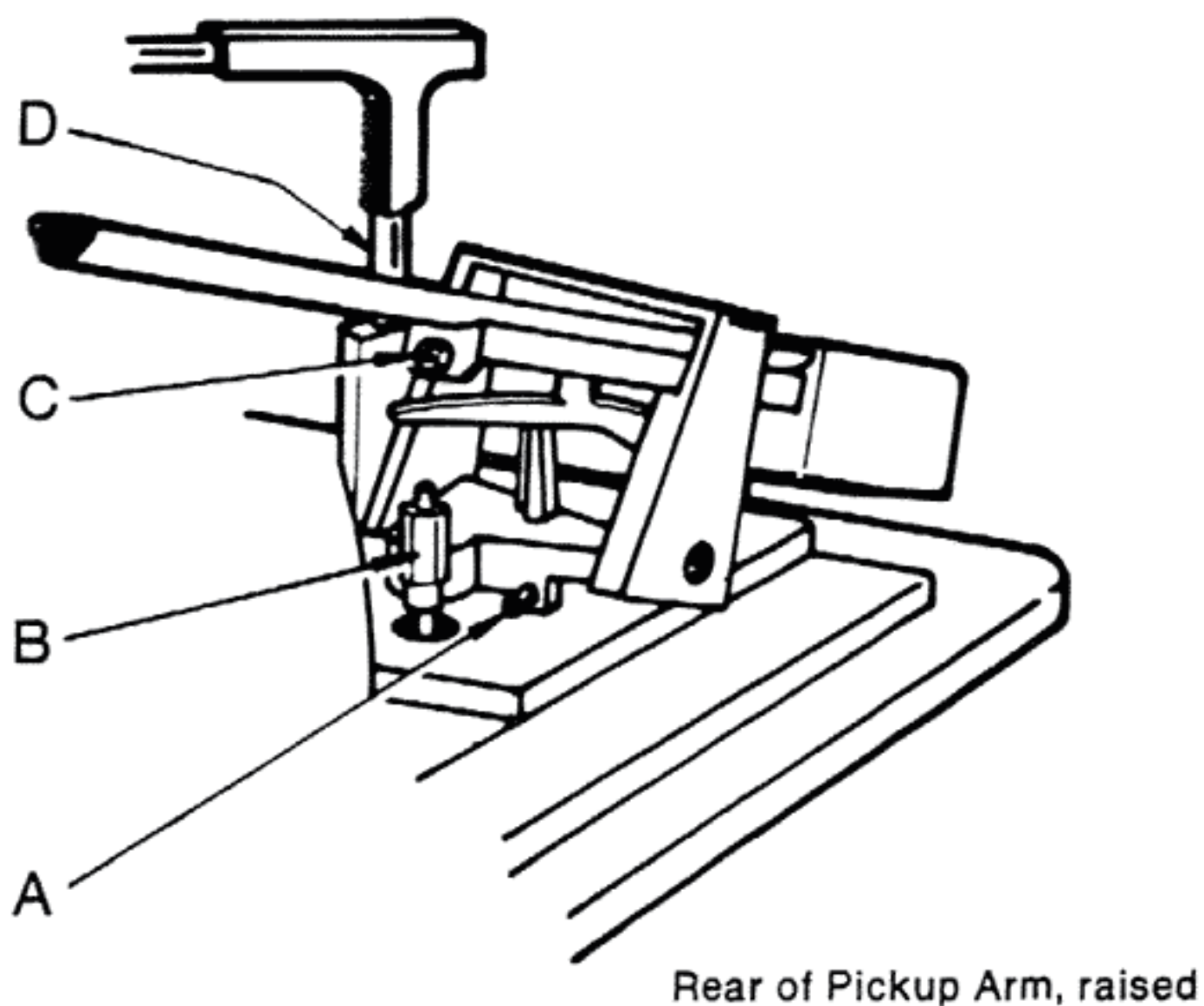

Diagram 12

Operating Instructions

(Different on single record players and 'Reverse Uni-mechs')

Setting up to operate (see diagram 13)

Remove the pickup stylus guard, if fitted, and check that the speed/size control and stylus are set to suit the records to be played. With pickup arm clipped to its rest, gently spin the turntable clockwise to ensure unit is not in auto cycle before fitting record spindle, which must be firmly located by retaining clip. Also check that transit screws are turned fully clockwise.

Automatic Play

1. If it is in its centre position (illustrated), lift the overarm and swing it to the right (as in Diagram 14).
2. Place records on the step of the record spindle and steady them by swinging the overarm into its centre position. (For a single record see the alternative below.)
3. Release the pickup rest clip then move the operating control to "Auto", pause and release. The control will return to "Manual".
4. After playing the last record the pickup will return to its rest and the unit will automatically switch off. Raise the overarm and swing it to the right, then lift the records clear of the spindle, even if replaying them.

Reject—Move the operating control to "Auto" (if playing a single record, or the last of a stack, immediately return the control to "Manual").

Single Record Play

Automatic—Fit the short record spindle. Lift the overarm and either swing it to the right or park it along the rear of the unit (see also Diagram 4) then place the record on the turntable. Check settings and move the operating control to "Auto", as above. The pickup will automatically lower on to the record.

Manual—as **Automatic**, but move the operating control to "Manual" and place the pickup on the record by hand.

Cue and Pause (not Models 6-200 and 6-100)—When playing a single record, the cue and pause control may be used to raise or lower the pickup at any selected point, or temporarily interrupt play. To raise the pickup, lift the cue and pause control then position the pickup manually, if required. To gently lower the pickup, lower the control. Note that a technique of lifting the control just sufficiently for the stylus to clear any warp in a record, allows a shorter descent time and greater precision in aligning the stylus over the selected record groove.

Repeat—Move the operating control to "Auto".

Stop

Move the operating control to "Off" and clip the pickup arm to its rest by hand.

Note

Make sure that at least one record is either on the record spindle or turntable before moving the operating control to "Auto" and do not leave the records on the unit when not in use. Store and clean records as recommended by the makers and keep the pickup stylus free of dust build-up. If transporting the unit, turn transit screws fully counterclockwise.

Clip the pickup to its rest.

A short record spindle is supplied and an adaptor for large hole records is available as an optional extra for playing a single record.

For playing a stack of large hole records, spindle F.45 is available.

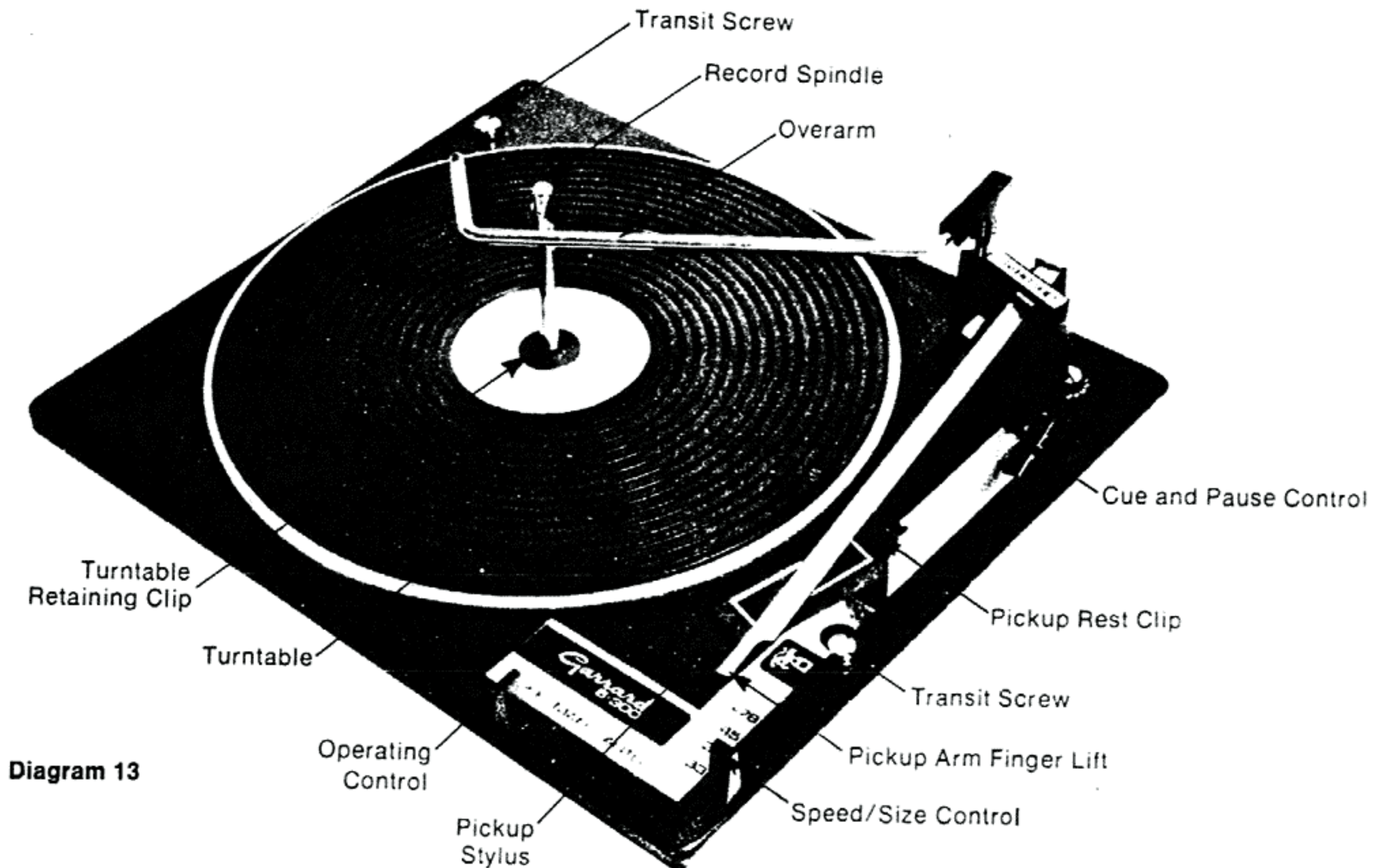

Diagram 13

PARTS LIST FOR MODEL 6-300 (ALSO MODELS 6-100 AND 6-200)

When ordering spares, quote the model type, code (from inspection label), part number, colour if part is enamelled or plastic, and voltage range for motor parts.
Note: Model 6-300 code is 76070 plus its following 3-figure stroke number. Similarly Model 6-100 code is 76050 and Model 6-200 code is 76060.
 Exploded view service sheet supplements are available for other models referred to in this manual.

| Ref. No. | Garrard Part No. | Description | Ref. No. | Garrard Part No. | Description | Ref. No. | Garrard Part No. | Description |
|----------|------------------|---|----------|------------------|---|----------|------------------|---|
| 1 | 75894 | Overarm Rear Trim | 47 | 01242/009 | Screw for Line Cord Socket (quote 999/4/01242/009) | 95 | 75633 | Intermediate Wheel Unit |
| 2 | 76083 | Plug for Pickup Arm | 48 | 44549 | Spring | 96 | 41219/010 | Plastic Washer |
| 3 | 75883 | Counterbalance Weight Support | 49 | 60643 | Plug-in Loom Assembly with Switch (quote Motor details) | 97 | 00431/010 | Spring Clip (quote 999/4/00431/010) |
| 4 | 76015 | Trim Weight (6-100 and 6-200) | 50 | 74017 | Spring Blade | 98 | 77177 | Transit Screw |
| 4 | 75950 | Counterbalance Weight — Heavy (6-300) State Cartridge type — Light (6-300) for correct weight | 51 | 00432/007 | Spring Clip (quote 999/4/00432/007) | 99 | 76318 | Turntable and Mat Assembly (6-200 and 6-300) |
| 5 | 75883 | Counterbalance Weight Support | 52 | 74013 | Release Lever Unit | 100 | 43874 | Turntable Retaining Clip |
| 6 | 76240 | Pickup Arm complete (6-100 and 6-200) — state Cartridge type | 53 | 00432/007 | Spring Clip (quote 999/4/00432/007) | 101 | 76322 | Centre Disc (3 inch dia.) |
| 6 | 75951 | Pickup Arm complete (6-300) — state Cartridge type | 54 | 76857 | Switch Lever Unit (use with torsion spring 44562) | 102 | 78265 | Overarm Assembly (with Item 1) |
| 6 | 75937 | Pickup Arm Tube | 55 | 00432/007 | Spring Clip (quote 999/4/00432/007) | 103 | 74510 | F45 Large Hole Record Automatic Adaptor |
| 7 | 75941 | Centre Disc 1½" dia. | 56 | 75896 | Control Link | 104 | 76011 | Automatic Record Spindle |
| 8 | 75961 | Turntable and Mat assembly (6-100) | 57 | 30950/001 | Push-on Retainer (quote 999/4/30950/001) | 105 | 72698 | Large Hole Record Adaptor |
| 9 | 76021 | Name Plate | 58 | 75881 | Control Lever Unit | 106 | 72094 | Single Play Spindle |
| 10 | 76472 | Pickup Body with Bearing | 59 | 74011 | Forked Control Link | 107 | 30969 | Spring Clip (quote 999/4/30969/001) |
| 11 | 01145/002 | Screw (quote 999/4/01145/002) | 60 | 75955 | Sub-plate Mechanism Assembly complete (6-100 and 6-200) | 108 | 76019 | Retains Overarm Spring 44559 when fitted |
| 12 | 01145/002 | Screw (quote 999/4/01145/002) | 60 | 76074 | Sub-plate Mechanism with Cueing, etc. (6-300) | 108 | 75891 | Pickup Head — Narrow (illustrated) |
| 13 | 77710 | Adjusting Plate Assembly | 60 | 75998 | Sub-plate and Pins only | 109 | 30959/001 | Pickup Head — Wide |
| 14 | 41218/006 | Washer | 61 | 00290/004 | Spring Clip (quote 999/4/00290/004) | 109 | 30959/001 | Screw (quote 999/7/30959/001) |
| 15 | 75943 | Control Trim Plate (6-100) | 62 | 00432/007 | Spring Clip (quote 999/4/00432/007) | 110 | 30959/001 | Screw (quote 999/7/30959/001) |
| 15 | 76031 | Control Trim Plate (6-200) | 63 | 58174 | Cushion Ring | 111 | 76341 | Pickup Head Weight |
| 15 | 75964 | Control Trim Plate (6-300) | 64 | 73975 | Thrust Washer | 112 | | Cartridge Bracket (state Cartridge type) |
| 16 | 75018 | Lifting Pin | 65 | 72230 | Ball Race Assembly | 113 | 59048 | Pickup Hardware Kit (Screw and Weight) State Cartridge type |
| 17 | 44476 | Overload Spring | 66 | 73975 | Thrust Washer | 114 | | Pickup Cartridge (state type) |
| 18 | 01577/049 | Screw (quote 999/4/01577/049) | 67 | 73969 | Cycle Control Lever Unit | 115 | 75081 | Pickup Lead Assembly (state Cartridge type) |
| 19 | 75944 | Cover Trim (6-100 and 6-200) | 68 | 00432/007 | Spring Clip (quote 999/4/00432/007) | 116 | 02321/005 | Screw — 2 off (quote 999/4/02321/005) |
| 20 | 75884 | Speed, Size Control | 69 | 00432/007 | Spring Clip (quote 999/4/00432/007) | 117 | 75959 | Support Bracket Assembly |
| 21 | 75970 | Speed, Size Control Link | 70 | 00432/007 | Spring Clip (quote 999/4/00432/007) | 118 | 75017 | Pickup Height Adjusting Nut |
| 22 | 76262 | Speed Change Lever | 71 | 44422 | Spring for Cycle Control Lever | 119 | 77177 | Transit Screw |
| 23 | 02664/005 | Push on Retainer (quote 999/4/02664/005) | 72 | 76300 | Main Cam Assembly | 120 | 00525/103 | Pickup Lowering Position Adjustment Screw (quote 991/4/00525/103) |
| 24 | 75895 | Speed Cam | 73 | 60660 | 4-pole Motor (quote Motor details) | 121 | 44411 | Intermediate Wheel Spring |
| 25 | 01515/006 | Screw (quote 999/4/01515/006 — 6-300) | 73 | 60580 | 2-pole Motor (quote Motor details) | 122 | 76051 | Pickup Rest Assembly |
| 26 | 75981 | Bias Control Knob (6-300) | 73 | 60810 | Synchro-Lab Motor (quote Motor details) | 123 | 02321/005 | Pickup Rest Screw (quote 999/4/02321/005) |
| 27 | 76020 | Cueing and Bias Compensator Assembly (6-300) | 74 | 00431/024 | Spring Clip (quote 999/4/00431/024) | 124 | 43855 | Transit Clip |
| 28 | 44518 | Spring (6-300) | 75 | 01577/050 | Screw (later, as item 57) | 125 | 44366 | Cueing Adjustment Screw |
| 29 | 76294 | Bias Spring Anchor Assembly (6-300) | 76 | 01577/050 | Screw (quote 999/4/01577/050) | 126 | 01144/076 | Screw (quote 999/4/01144/076) |
| 30 | 75967 | Cueing Knob (6-300) | 77 | 74639 | Not used on later units | 127 | 00432/007 | Spring Clip (quote 999/4/00432/007) |
| 31 | 74007 | Friction Lever Assembly | 77 | 76079/015 | Lead Clip | 128 | 42932 | Tag |
| 32 | 75487 | Switch oil Lever | 78 | 76079/002 | Control Cover Assembly (6-100) | 129 | 44980 | Spring |
| 33 | 41218/042 | Washer | 78 | 76079/002 | Control Cover Assembly (6-200) | 130 | 01144/076 | Screw (quote 999/4/01144/076) |
| 34 | 76232 | Swing Lever Unit | 78 | 76079/013 | Control Cover Assembly (6-300) | 131 | 76073 | Pickup Base Assembly |
| 35 | 43200 | Ball | 79 | 00852/012 | Shakeproof Washer (quote 999/4/00852/012) | 132 | 01144/076 | Screw (quote 999/4/01144/076) |
| 36 | 44546 | Spring | 80 | 00451/002 | Nut (quote 991/4/00451/002) | 133 | 01577/049 | Screw (quote 999/4/01577/049) |
| 37 | 44572 | Spring | 81 | 78957 | Damping Pads (3 off) | 134 | 44410 | Index Spring |
| 38 | 73899 | Lower Bearing | 82 | 73542 | Mounting Spring and Pad Assembly (3 off) | 135 | 01577/050 | Screw (quote 999/4/01577/050) 3 off |
| 39 | 76564 | Pickup Earth Tag | 83 | 00852/012 | Shakeproof Washer (quote 999/4/00852/012) | | | Not used on later units |
| 40 | 42946 | Standard Pickup Connector Tags (5 off) | 84 | 00451/002 | Nut (quote 991/4/00451/002) | 136 | 75954 | Unit Plate Assembly |
| 41 | 73532 | Pickup Phono Socket | 85 | 00852/012 | Shakeproof Washer (quote 999/4/00852/012) | 137 | 00431/001 | Spring Clip (quote 999/4/00431/001) |
| 41 | 73057 | Pickup Connector Tag Strip (not illustrated) | 86 | 00451/002 | Nut (quote 991/4/00451/002) | 138 | 76969 | Pivot Spindle |
| 42 | 01577/049 | Screw for Phono Socket or Tag Strip (quote 999/4/01577/049) | 87 | 43140 | Rubber Grommet | 139 | 75948 | Adjustment Bracket |
| 43 | 00852/012 | Shakeproof Washer (quote 999/4/00852/012) | 88 | 02654/001 | Spring Clip (quote 999/4/02654/001) | 140 | 44448 | Spring |
| 44 | 01577/049 | Screw (quote 999/4/01577/049) | 89 | 43140 | Rubber Grommet | 141 | 75887 | Pivot Bracket |
| 45 | 01577/050 | Screw (quote 999/4/01577/050) | 90 | 02654/001 | Spring Clip (quote 999/4/02654/001) | 142 | 00431/001 | Spring Clip (quote 999/4/00431/001) |
| 46 | 76483 | Bracket for Line Cord Socket | 91 | 43140 | Rubber Grommet | 143 | 41218/087 | Washer |
| | | | 92 | 02654/001 | Spring Clip (quote 999/4/02654/001) | 144 | 76245 | Nut |
| | | | 93 | 43855 | Transit Clip | 145 | 44528 | Stylus Force Spring |
| | | | 94 | 41219/005 | Fibre Washer | 146 | 44295 | Screw |

GARRARD MODEL 6-300 EXPLODED VIEW ALSO MODEL 6-100 AND MODEL 6-200

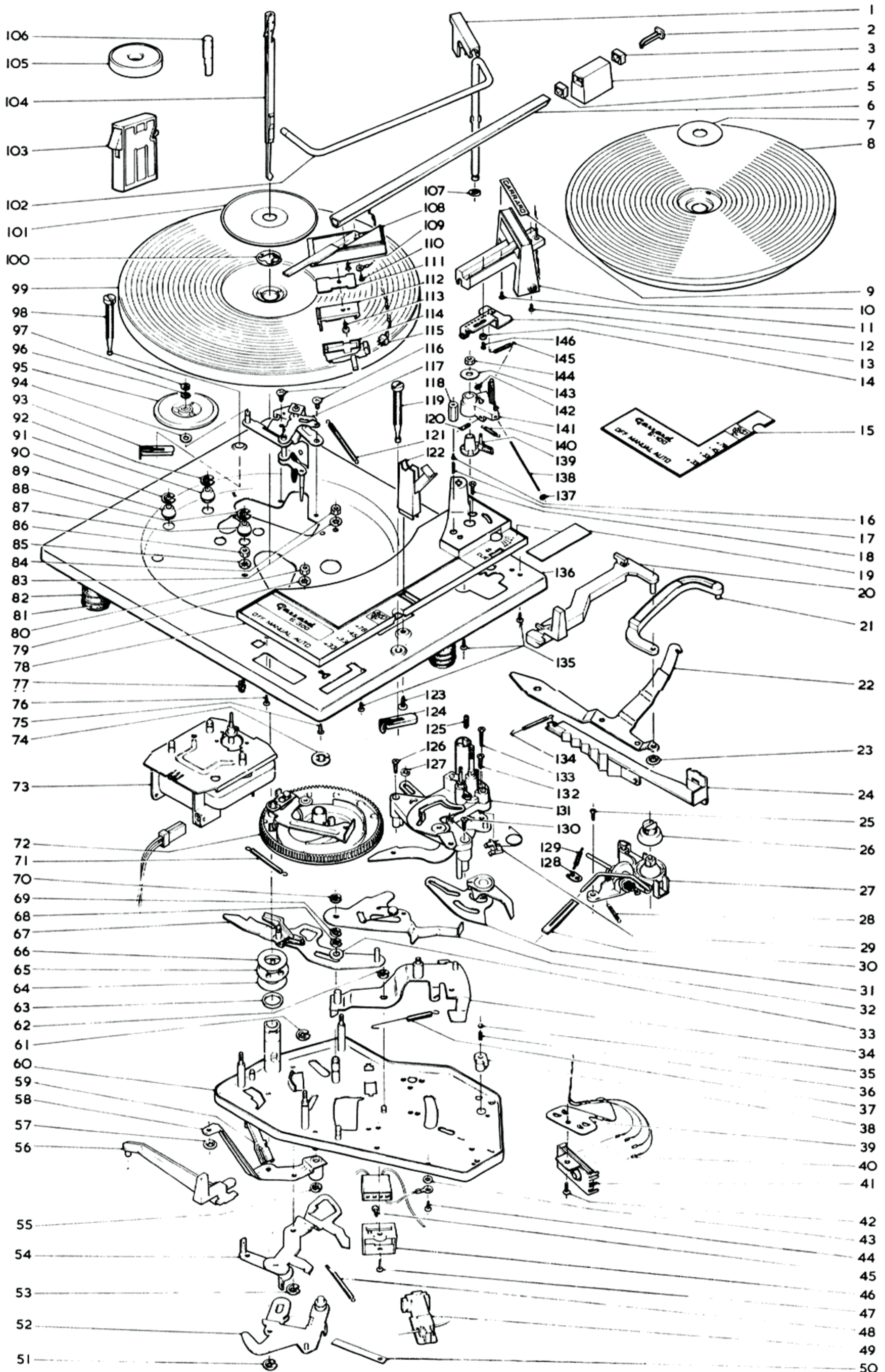

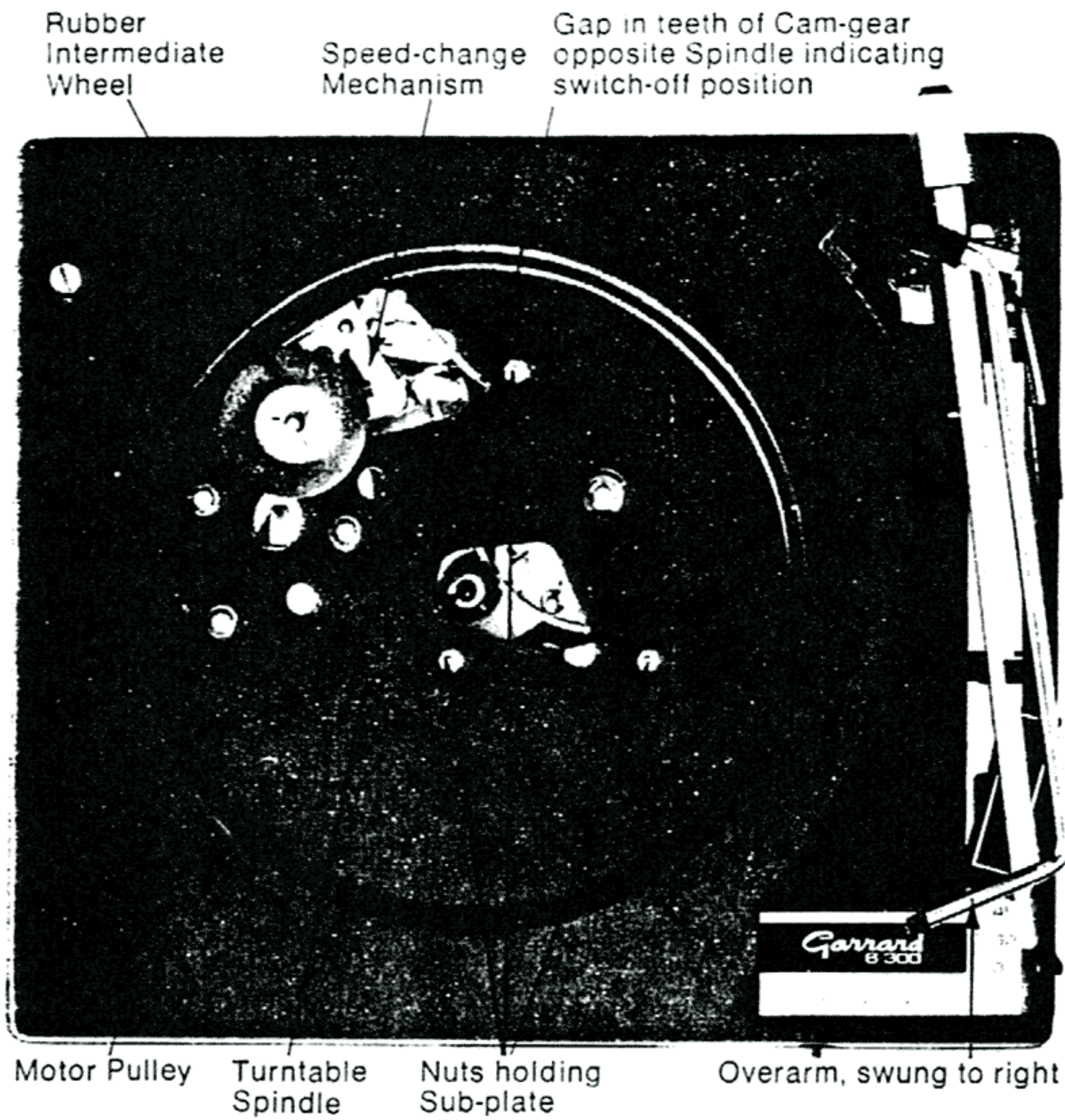

Diagram 14

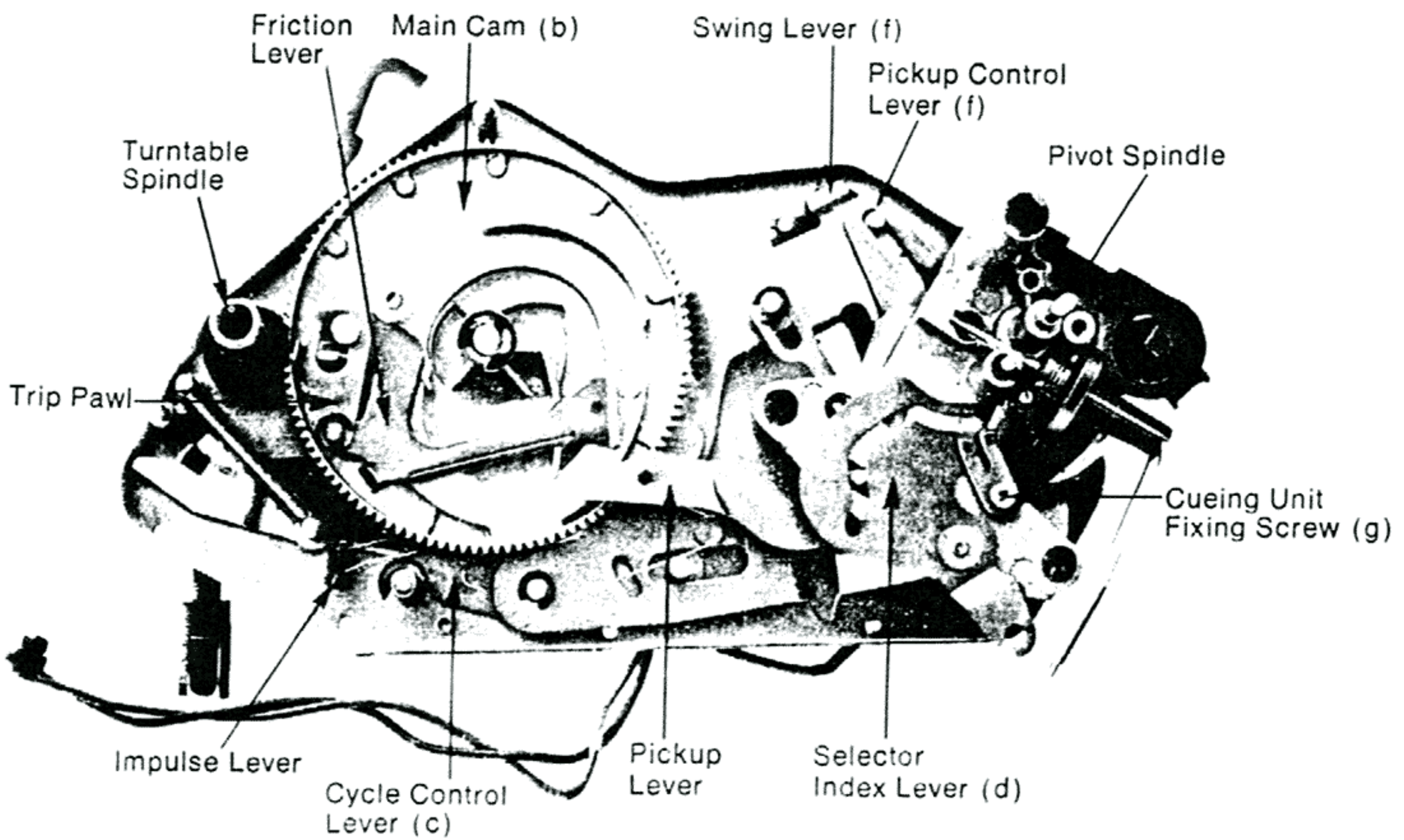

Diagram 15

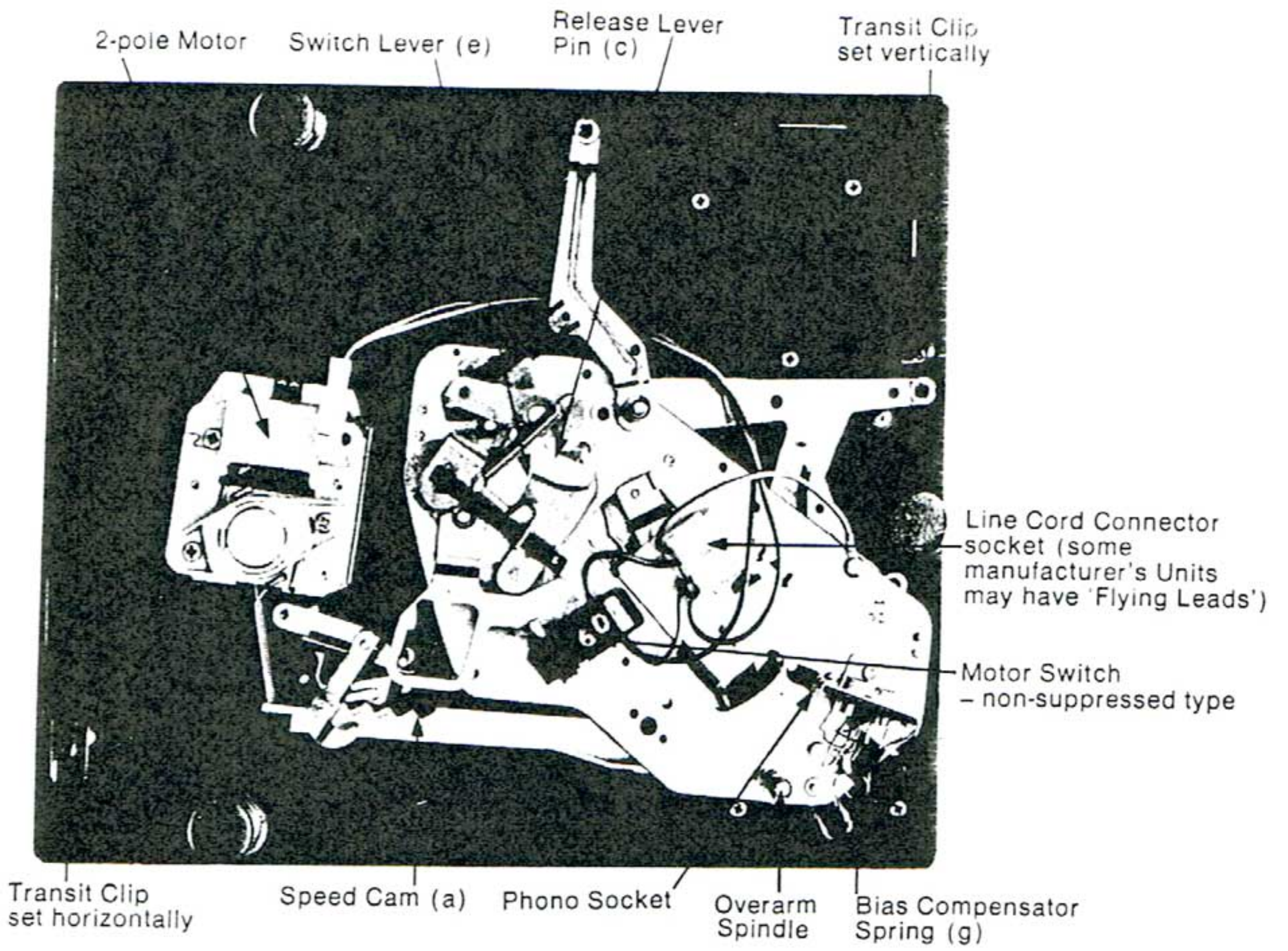

Diagram 16

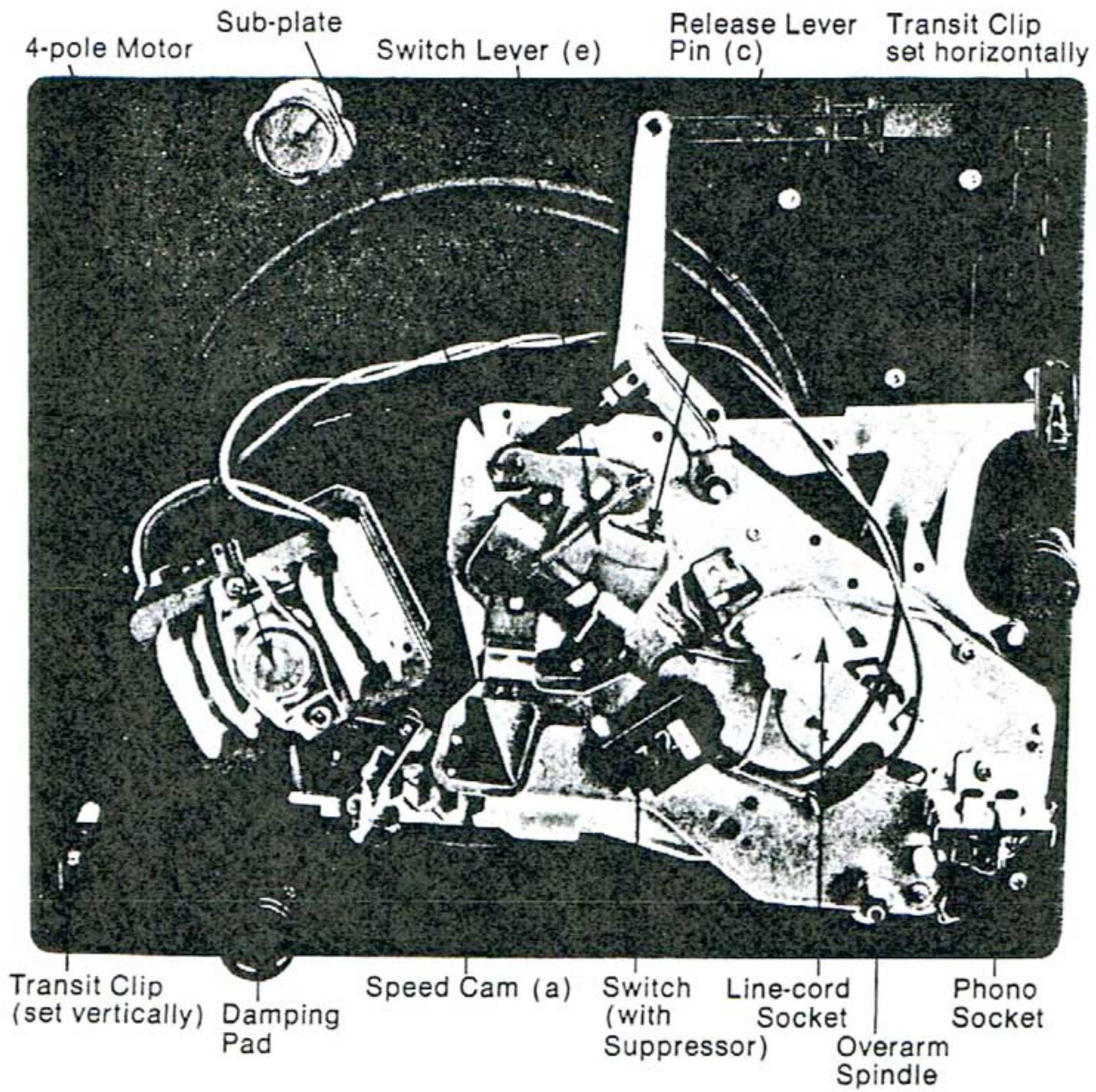

Diagram 17

Maintenance

To obtain the best results from records, store and clean them as recommended by the record manufacturers. Do not leave records on the unit when not in use. Keep the stylus free from accumulated dust and replace it when worn.

Disconnect the power supply and protect the stylus before carrying out maintenance. Numbers in brackets refer to the exploded view.

To Remove Turntable

Withdraw the record spindle and carefully take out the centre disc from the turntable mat, then remove the turntable retaining clip, noting the location, and lift off the turntable.

The Overarm (when fitted)

The overarm must lower freely when swung to its "in" position, so that it steadies records stacked on the record spindle. If the overarm is stiff, apply a spot of oil to the overarm spindle at points (F) and (D) — see Diagrams 11 and 12.

Note that on certain units, overarm downwards movement is assisted by a compression spring. The spring (when fitted) is retained on spindle by clip (107).

Lubrication

The oil retaining bearings of the motor and intermediate wheel (95) and of the turntable rarely need lubricating.

When the need is apparent, remove the turntable and lubricate these bearings and the turntable ball race (65) with a spot of fine grade machine oil. Carefully remove any excess, particularly from the motor pulley, intermediate wheel (95) and inside turntable rim by wiping these driving surfaces with a clean cloth.

If stiffness of operation becomes noticeable, pivot points such as pivot pins, spindles, rollers and spring anchors, also working faces can be lubricated sparingly with fine oil or thin grease, if appropriate.

More specifically, grease as follows. Letters (a) to (f) refer to diagrams 15, 16 and 17:

- (a) Both sides of speed cam (24) and where it bears on unit plate and support bracket (117).
- (b) Track of main cam (72).
- (c) Edge of cycle control lever (67) where it contacts release lever pin (52), also top face of keyhole slot in cycle control lever.
- (d) Cam profile of selector index lever on top of pickup base assembly (131).
- (e) Cam face and bearing faces of switch lever (54) and control catch on sub plate (60) where switch lever unit engages.
- (f) Pin in swing lever (34) running in cam slot of pickup control lever on pickup base (131), also where swing lever (34) bears on sub-plate (60) and lifting incline of swing lever.

- (g) The cueing mechanism on Model 6-300 is partially damped by special silicone fluid of 500,000 c St viscosity which is factory-sealed. Removal of screw (25) and spring (29) allows the mechanism (27) to be withdrawn from the dismantled sub plate for cleaning and re-charging if required however.

Also apply a smear of petroleum jelly to the sliding faces of the switch plunger (49), if required.

Avoid getting grease between the working surfaces of the switch-off lever (32) and sub-plate (60).

Speed

Speed variation may be caused by warped records slipping on one another. If so, play singly or put a small piece of adhesive tape on record labels to improve drive. Check that there is no lubricant on the driving surfaces of the motor pulley, intermediate wheel or turntable causing the drive to slip. Check, too, that the rubber intermediate wheel height is set correctly to the appropriate motor pulley step without rubbing the side of the adjacent step. Adjust the height setting if necessary — See Diagram 18.

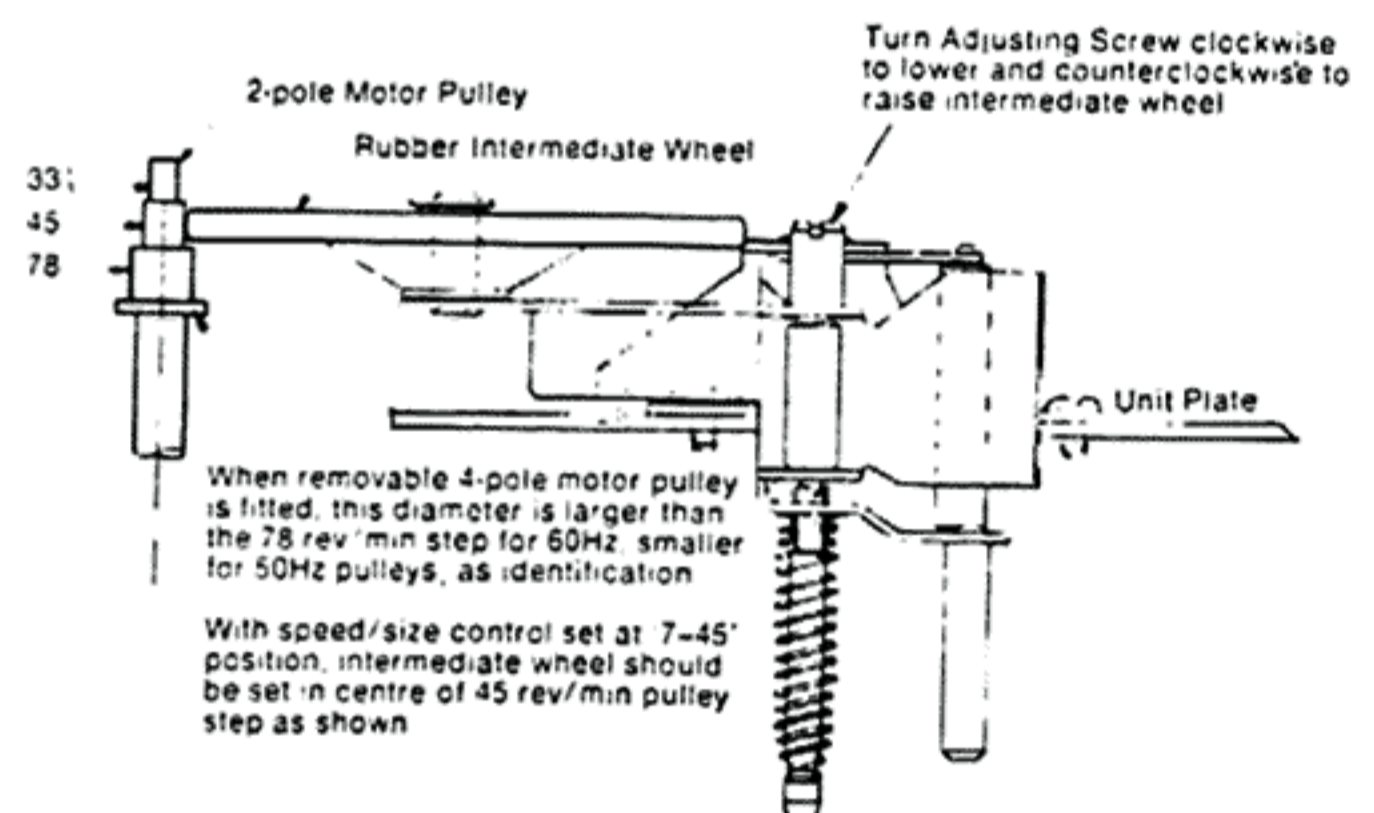

Diagram 18

Motor

If speed is consistently fast or slow, check that the power supply details marked on the motor correspond to the power supply.

If the motor fails to start, check the power supply to the motor, then with the power supply disconnected check the connections to the switch and motor, making sure they are secure, with the plug-in bobbin leads firmly in sockets.

Dismantling

To remove sub-plate. (Numbers in brackets refer to exploded view.)

1. Withdraw overarm (102) when fitted — the overarm can be withdrawn completely when swung parallel with rear of unit and its spring clip (107) removed (also the spring on the spindle on some units).
2. Remove turntable (99) — see "Maintenance" section.
3. Unplug loom (49) from motor bobbin — pull plug from socket while carefully wedging thin screwdriver blade between faces to unlock pip location. (Two plugs on 4-pole motors.) Also withdraw clip retaining lead to unit plate (77).
4. Disconnect pickup lead connections at tag strip (41) — usually push-in or crimped tags. Also remove any tape holding leads.
5. Remove pickup arm pivot nut (144) and washer (143), then withdraw pickup arm (6) — note path of pickup leads (115).
6. Remove plastic height adjusting nut (118) and self-tap screw (18) holding pickup base cover (78).

Pickup Tracking

To track correctly, the pickup stylus force must be that recommended for the cartridge fitted (not less than 2½ grams for these models), the stylus must be clean and not worn and pickup arm movement must not be affected by any restriction such as tight pickup leads at the rear of the arm.

Also, the unit should be reasonably level, and of course the cue and pause control must be in its lowered position when applicable.

7. Remove self-tap screws (76) and (135) — not used on later units, set speed/size control to "12-33" and remove pickup rest screw (123) and self-tap screw (75).
8. Remove control cover (78). On Model 6-300 this will be assisted by first pulling off the cueing knob (30) from the cue and pause control.
9. Remove bias control knob (26) on Model 6-300.
10. Remove spring clip (55) to disconnect control mechanism.
11. Carefully disconnect forked control link (59) from control lever (58).
12. Remove self-tap screw (132).
13. Remove the three 4BA nuts and washers (79, 80, 83, 84, 85 and 86) holding the sub plate and carefully withdraw the sub plate (60) and mechanism.

When reassembling the sub-plate and mechanism, make sure that the intermediate wheel withdraw pin on support bracket assembly (117) comes inside the cam ring on switch lever unit (54). Also check that the locating pip on speed size lever (21) will pivot the selector index lever attached to pickup base assembly (131).

FAULT CHART

THE UNIT SHOULD BE DISCONNECTED FROM ITS POWER SUPPLY AND THE STYLUS PROTECTED BEFORE MAKING SERVICE ADJUSTMENTS. NUMBERS IN BRACKETS REFER TO THE EXPLODED VIEW.

This chart may be used as a guide for all the models in this series.

| FAULT | CAUSE | CORRECTION |
|---|---|---|
| TURNTABLE SPEED Turntable fails to start or runs slowly when switched on. | 1. Oil or dirt on driving surfaces. | 1. Remove turntable and clean inside of rim, periphery of intermediate wheel (95) and motor pulley (73). |
| | 2. Faulty intermediate wheel spring (121). | 2. Check that tension spring (121) is anchored to the unit plate and support bracket assembly (117). When the operating control is turned to "Manual", spring (121) should pull the support bracket assembly into engagement with motor pulley. If it does not, and the tapered pin beneath the support bracket assembly (117) is not found to be bent, replace spring (121). |
| | 3. Pivots on support bracket assembly (117) not free. | 3. Wheel (95) should engage motor pulley firmly when the unit is switched on and retract when switched off. Lubricate the two pivot spindles on the support bracket assembly if they appear to be tight. Replace the support bracket mechanism if damaged. |
| | 4. No power supply. | 4. Remove plug (49) from motor (73), switch on and check with voltmeter. If no reading, check back to source outlet, looking for loose connections, faulty switch contacts, etc. |
| | 5. Faulty motor coil. | 5. Remove plug (49) from motor (73) to check continuity of coil with an ohm-meter. Replace motor if necessary. (Two plugs and two coils on 4-pole motor.) |
| | 6. Bearings of motor (73) out of line. | 6. If the rotor shaft is tight, tap the motor body with a small block of wood such as a screwdriver handle to realign bearings. Use only fine machine oil such as used for sewing machines on these bearings. |
| | 7. Intermediate wheel (95) height set incorrectly. | 7. Set as described under "Maintenance" and Diagram 18. |
| | 8. Bearings not free. | 8. Check motor (73) intermediate wheel (95) and turntable bearings for free running. See lubrication section under "Maintenance". |
| | 9. Wrong pulley (4-pole motor). | 9. A 60Hz pulley will run the unit slowly on 50Hz supply. (The pulley base diameter is smaller than the 78 rev/min pulley step for 50Hz and larger for 60Hz as identification). |
| Record speed varies (Wow and Flutter). | 1. Various. | 1. See "Turntable Speed" above, Causes and Corrections 1, 7 and 8. |
| | 2. Warped records in stack causing slipping. | 2. It is not advisable to play badly warped or dished records automatically, although small strips of adhesive tape on their labels may help adjacent records to key together. |
| | 3. Damaged rotor shaft of motor (73). | 3. Replace motor (73). |
| | 4. Flats on driving surface of intermediate wheel (95). | 4. If running the unit for a while does not cure the fault, replace the wheel (95). (Do not switch the unit off from the power supply before it has stopped automatically, as the unretracted wheel (95) may form flats.) |

| FAULT | CAUSE | CORRECTION |
|--|--|---|
| RECORD DROPPING Records fail to drop. | <ol style="list-style-type: none"> 5. Motor pulley slipping (4-pole motor). 1. Damaged record spindle. 2. Moulding flash or label paper in centre hole of new record. 3. Non-standard records. 4. Spring blade (50) not positioned correctly. 5. Record spindle not seated properly. | <ol style="list-style-type: none"> 5. Check that the two pulley lock screws on the 4-pole motor are equally tight. 1. Remove spindle and check that its record pushing pawl moves freely. If not, replace spindle. 2. Remove carefully with a penknife. 3. L.P. records with oversized centre holes, or more than .090" thick at the centre hole may fail to drop. Play them manually. 4. Check that the end of spring blade (50) applies pressure to the bottom of the record spindle pawl. 5. Make sure that the spindle is located firmly by the clip (100) with the spindle step positioned as in Diagram 13. Never attempt to fit or remove the record spindle during an auto cycle. |
| Two or more records drop together. | <ol style="list-style-type: none"> 1. Damaged record spindle. 2. Tight overarm (when applicable). 3. Non-standard records. | <ol style="list-style-type: none"> 1. Check that both the latches at the top of the record spindle move up and down freely. If necessary straighten and clean but do not oil them. Replace spindle if faulty. 2. Check that the overarm steadies a stack of records on the spindle step. Apply a spot of oil at points (F) and (D), on Diagrams 11 and 12 if the overarm is tight. Check that, if fitted, spring on overarm spindle is retained by clip (107). 3. L.P. records less than .053" thick at centre holes. Play them singly. |
| PICKUP ARM MOVEMENT Pickup tracks incorrectly. | <ol style="list-style-type: none"> 1. Stylus force too low. 2. Dust accumulated around stylus tip. 3. Worn or wrong size of stylus tip radius. 4. Pickup leads tight or trapped at rear of arm. 5. Groove guard on record (raised rim). 6. Linkage not free. 7. Cueing mechanism engaged (if fitted). | <ol style="list-style-type: none"> 1. Check that the force is not lower than that recommended for the cartridge. Adjust if necessary — see "Stylus Force Adjustment", page 5. 2. Clean carefully. 3. Replace stylus. 4. Make sure leads are slack and check that they are not caught in or touching mechanism below the unit plate. 5. If the stylus lands too far out it may slide down the slope of the raised rim on certain records and jump the first playing grooves. Reset pickup lowering position so that it lands further in (see "Adjustments"). 6. Check that the pickup lever on pickup base (131) is not restricted while the pickup arm tracks a record. The pickup lever is also illustrated on Diagram 15. 7. Check that the cue and pause control is fully in its down position, and that the cueing mechanism is not set too high. Also check spring (129) is attached. |

| FAULT | CAUSE | CORRECTION |
|---|--|--|
| 8. Pickup bearings not free. | 8. Neither the pickup bearings for vertical movement nor the horizontal movement bearing should require attention. Check, however, that with the arm unclipped and out of cycle there is free movement when the arm is moved up and down and sideways. If tight, carefully spring off the rear moulding (10) from its pivot bracket and check that there is no dirt on the pivots or the bearing holes. Check, too, that spring (36) exerts a light pressure, lifting the pickup vertical pivot spindle — when the arm is pressed over this spindle there should be some movement against spring (36). If not, check lower bearing (38) is square in sub-plate (60). | |
| 9. Body of pickup cartridge (114) touches record. | 9. Make sure any cartridge fixing screws are secure and that cartridge bracket or clip-in plates are assembled correctly. | |
| Pickup arm fails to leave rest. | 1. Damaged trip pawl on main cam (72). 2. Damaged friction lever on main cam (72). | 1. Reshape vertical lug or replace cam assembly (72). 2. Check that the lug on friction lever going through main cam (72) is square. See Diagram 15. |
| Pickup arm fails to lift and cycle at end of record, or the arm lifts too soon. | 1. Damaged trip pawl or friction lever on main cam (72). 2. Pickup arm lowering position set wrongly. 3. Pickup pivot spindle on pickup base (131) set to wrong angle. 4. Non standard record. | 1. As Corrections 1 and 2 under "Pickup arm fails to leave rest" above. 2. Check lowering position — see "Adjustments" section. 3. The cast adjusting bracket on the pickup arm is located on flats on the pickup pivot spindle. If the flats are set at the wrong angle, the pickup base assembly (131) should be replaced. 4. "Reject" at end of record. |
| Pickup arm lands on record too far in or out. | 1. Lowering position incorrectly set. 2. Pickup bearings not free or spring (140) weak. | 1. See under "Adjustments". 2. Check pickup bearings as Correction 8 under "Pickup tracks incorrectly". Check that when the pickup arm is moved horizontally into the turntable centre by hand, spring (140), acting as an overload spring, will draw the arm back so that screw (120) comes up against the stop face of the cast anchor bracket (139) for spring (140). If spring (140) is weak, replace it. |
| Pickup keeps on repeating the same record. | 1. Record spindle not located correctly. 2. Impulse lever tight. | 1. Check, that with the mechanism not in cycle, the record spindle is fully pushed down into its location. 2. Make sure that the plastic impulse lever mounted on cycle control lever (67) pivots freely. See Diagram 15. |

| FAULT | CAUSE | CORRECTION |
|--|--|---|
| Pickup keeps on repeating the same record. | 3. Swing lever (34) not laid flat. 4. Switch off lever (32) not engaging pickup lever on pickup base assembly (131). | 3. Check that swing lever (34) is flat against sub-plate (60) over its bearing area and is not twisted. 4. Make sure that the lug on the end of switch off lever (32) is bent square and makes contact with the side of the pickup lever during auto cycle. Check that the pins on the pickup lever are not bent. |
| Pickup selects wrong record size. | 1. Bent pin on pickup lever, on pickup base assembly (131). 2. Linkage disconnected. | 1. Make sure that the pins on the pickup lever are square to the lever. 2. Check that link (21) is connected to selector index lever (d) shown in Diagram 15. |
| NOISE Rumble heard through speaker(s) while playing a quiet passage. | 1. Rumble on record. 2. Lack of lubrication of drive mechanism. 3. Intermediate wheel (95) rubbing against side of motor pulley step. 4. Driving surface of intermediate wheel (95) dirty, indented or hardened. 5. Faulty installation. 6. Worn or dirty turntable spindle bearing (63), (64), (65) and (66). 7. Motor incorrectly mounted. | 1. Check, by playing other records, that a particular record is not at fault. 2. See lubrication section under "Maintenance". 3. Adjust the wheel height if necessary. See Diagram 18. 4. If running the unit for a while and cleaning the periphery of the wheel does not help, replace it. 5. Check that the unit rests freely on its mountings, and that no part of the mechanism is in contact with the mounting board. 6. Clean rubber cushion ring (63), thrust washers (64) and (66) and ball race (65). Oil the ball race (65). Replace worn bearings or the rubber cushion ring if hard. 7. Check that the motor is suspended correctly on its rubber grommets with the grommets (87 etc.) correctly assembled on the unit plate and with motor leads not caught up in the mechanism so as to pull the motor (73). |
| Interference heard as crackles, etc., through speaker(s). | 1. Faulty contact in power supply circuit, pickup circuit or earth connection. | 1. Examine all leads and connections for damage and check screws for tightness, also push-on tags. If the switch is faulty, fit a new loom assembly (49). |
| No sound. | Open circuit in pickup leads. | Check the continuity of the pickup leads from the cartridge to the tag strip. Make sure push-on tags are in position. Disconnect the cartridge before making this check. |

Garrard Engineering Limited
Newcastle Street
Swindon Wiltshire England
Telephone: Swindon (0793) 5381
Telex: 44271

Garrard

A Plessey Quality Product



76050 Issue 3