

Garrard MODEL 3000

4 SPEED RECORD CHANGER AND PLAYER

This unit has been engineered as a precision instrument and incorporates an ultra light weight Pickup Arm of exciting modern design and performance to which only high compliance cartridges should be fitted.

FEATURES

- ★ Plays automatically up to 8 records of 7", 10" or 12" diameter at the same speed and stylus setting.
- ★ Selects correct record size with records mixed in any order.
- ★ May be stopped and restarted without rejecting the record being played.
- ★ Fitted with brush for cleaning stylus manually.
- ★ Plays with ultra light stylus pressure.
- ★ May be used manually as a single record player.
- ★ Plays large centre hole 7"-45 r.p.m. records using spindle type L.R.S.10 (optional extra).

TO OPERATE

1. Set stylus to suit records and free pickup arm on rest.
2. Set speed control to correct speed.
3. Place records horizontally on record spindle step and swing overarm fully inwards.
4. Switch on by moving control to 'Auto'. After playing all records, pickup arm will return to rest and unit will switch off.

To unload:

1. Lift overarm and swing to right.
2. Lift records clear of spindle, even if replaying same records.

Manual operation:

1. Place record on turntable by threading over record spindle. Swing overarm fully inwards.
2. Switch on by moving control to 'Manual'. After playing record, pickup arm will return to rest and unit will switch off.

The record spindle may be replaced by the short manual spindle for manual operation.

INSTALLATION

When your equipment is installed, check that the 2 transit screws are screwed down clockwise allowing the changer to float freely on its suspension springs. For transporting, screw the transit screws counter-clockwise to lock the unit plate against the motor board.

See reverse for Maintenance, Service and Accessories.

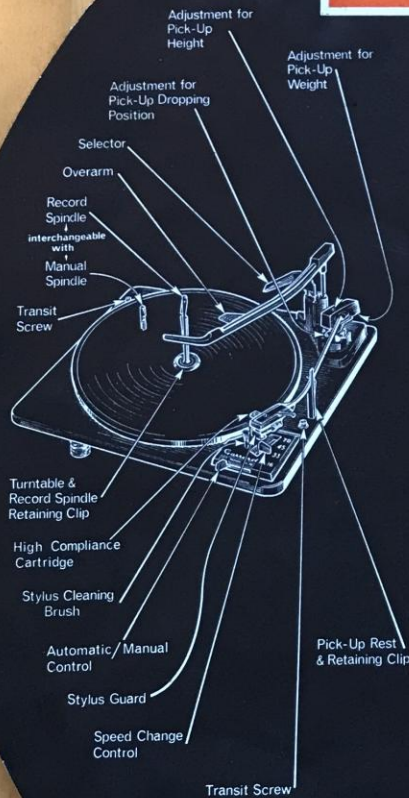

THIS IS YOUR SERVICE SHEET AND SHOULD BE CAREFULLY RETAINED



Reject:

A record being played may be rejected by moving control to 'Auto'.

Stop:

Move control to 'Off' and motor will stop with pickup remaining on record. Restart by moving control to 'Manual' and same record will continue playing.

Note:

To prevent stylus damage avoid switching to 'Auto' until records are loaded on record spindle.

To obtain best results, store and clean records as recommended by the record manufacturers.

Do not leave records on unit when not in use.

If you require advice not covered by this leaflet, please write to our Technical Service Department; for spare parts and service returns write to our Service and Spares Department.

Address: 50-54 Radnor Street, Swindon, Wilts. (Swindon 22606).
 Factory Address: Newcastle Street, Swindon, Wilts. (Swindon 5381).

Garrard

MODEL 3000

MAINTENANCE

The motor, turntable spindle and rubber intermediate wheel bearings are of the oil retaining type and rarely need lubricating. When the need for oil is apparent, remove the turntable and lubricate these bearings with a fine grade oil. Remove any excess oil, particularly from the motor pulley, rubber intermediate wheel and inside turntable rim by wiping these driving surfaces with a clean cloth. Oil pivot points if stiffness becomes noticeable.

To remove turntable:

Pull out the record spindle then prise out the turntable name plate, slide off the retaining clip, noting its position for reassembly, and lift the turntable with equal pressure on diametrically opposed sides.

The Overarm:

When swung fully inwards the overarm must drop freely in its location. If stiff, remove circlip on overarm spindle (beneath unit), withdraw overarm and clean and oil its spindle.

SERVICE ADJUSTMENTS

See that the unit is mounted horizontally in its cabinet by checking with a spirit level on the turntable.

Speed:

Speed variation may be caused by warped records slipping. If this is so, play singly or put adhesive tape on record labels

to improve drive. Oil on unit driving surfaces may cause speed variation (see Maintenance).

Should the turntable run fast or slow consistently, check that the motor and motor pulley match the power supply. The motor end cover is stamped with its power supply details and the motor pulley, if the removable type, is colour finished, nickel for 50 cycles and brass for 60 cycles power supply.

Check that the rubber intermediate wheel runs in the centre of the appropriate step on the motor pulley and is not rubbing the side of the adjacent step. If necessary adjust the intermediate wheel height setting blade.

This blue spring steel blade is found beneath the unit plate and adjust the position of the spindle on which the rubber intermediate wheel is mounted.

Pickup dropping positions:

This position may be adjusted if necessary by turning the horizontal tapered head screw beneath the pickup arm. Clockwise rotation moves arm in and counter-clockwise rotation moves arm out.

Pickup Height:

The degree of lift is adjusted by the vertical screw set in the rear top surface of the pickup arm. Turn clockwise to decrease and counter-clockwise to increase height. The stylus

above one record on the turntable mat as the arm returns to its rest. Switch to 'Off' at the appropriate point in the changer cycle to adjust pickup dropping position and height.

Pickup Pivots:

Pivots for horizontal pickup arm movement are greased and vertical movement pivots operate dry. These pivots should require no attention.

Stylus Pressure:

This is preset to the pressure recommended by the pickup cartridge manufacturer. Check occasionally, preferably with a Garrard Stylus Pressure Gauge. To adjust the stylus pressure, turn the knurled nut on the underside of the pickup arm clockwise to decrease and anti-clockwise to increase stylus pressure (pickup weight).

Pickup:

When in 'Off' position, occasionally swing pickup arm over brush, so that the stylus point is cleaned of dust build up. Replace stylus when worn. Some units are fitted with a flexible pickup lift restrictor which must be turned aside to raise the pickup arm when examining the stylus.

GARRARD STYLUS PRESSURE GAUGE MODEL SPG3

AN INDISPENSABLE ACCESSORY FOR THE ENTHUSIAST

- Easily readable scale, visible through a clear plastic window, reading 0-12 grammes, with $\frac{1}{4}$ gramme indications
- Accurate through the entire scale, 0-12 grammes
- Plastic Scale Pan—no damage to delicate stylus
- Will accommodate all current Pickup Arms and Heads
- Supplied complete with a 5 gramme checking weight.

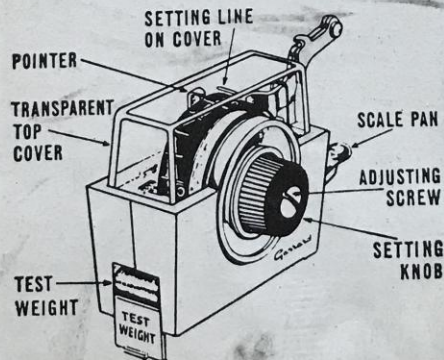

OBTAINABLE FROM YOUR LOCAL DEALER

71177
Printed in England

LARGE RECORD SPINDLE LRS 10

For use when playing records with large centre hole



Short spindle for manual operation