

SERVICE MANUAL

PRICE \$1.00

TX-2000

SERIAL NUMBERS
BEGINNING 50001



The Fisher[®] TX-2000

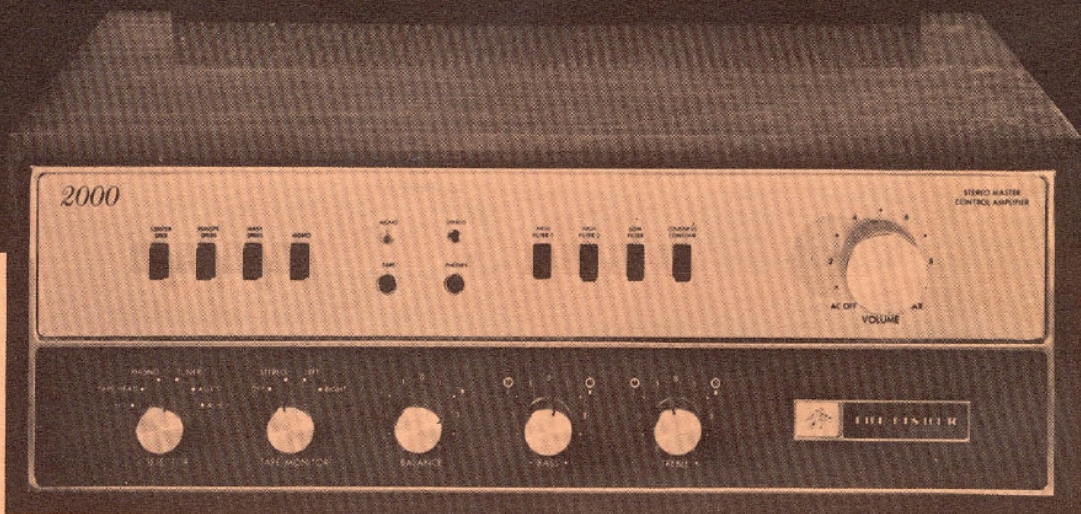

WORLD LEADER IN HIGH QUALITY STEREO

TEST EQUIPMENT AND SERVICE TIPS

The following equipment is required to completely test and align modern high-fidelity amplifiers, tuners, and receivers.

Line Voltage Autotransformer or Voltage Regulator	10.7 MHz Sweep Generator
DC Vacuum Tube Volt ohmmeter	Multiplex Generator (preferably with RF output)
Accurately Calibrated AC Vacuum Tube Voltmeter	455 kHz Sweep Generator
Oscilloscope (Flat to 100 kHz Minimum)	Ferrite Test Loop Stick
Low-Distortion Audio (Sine Wave) Generator	2 – Full Range Speakers for Listening Tests
Intermodulation Distortion Analyzer	Stereo Source – Turntable, Tape Recorder, etc.
Harmonic Distortion Analyzer	Soldering Iron with Small Tip, Fully Insulated from AC Line
2 – Load resistors, 8-Ohms, 100 Watt (Minimum Rating)	Suction Desoldering Tool
AM/FM Signal Generator	

CAUTION: This precision high-fidelity instrument should be serviced only by qualified personnel, trained in the repair of transistor equipment and printed circuitry.

Many of these items are included only as a reminder — they are normal procedures for experienced technicians. Shortcuts may be taken, but these often cause additional damage to transistors, circuit components, or printed circuit boards.

SOLDERING: A well-tinned, hot, clean soldering iron tip will make soldering easier, without causing damage to the printed circuit board or the components mounted on it. Regular use of a sponge cleaner will maintain a clean soldering surface. The heat available at the tip, (not the wattage of the iron) is important. Some 50-watt irons reach temperatures of 1,000° F, while others will hardly melt solder. Small-diameter tips should be used for single solder connections, pyramid and chisel tips for large areas.

Always disconnect the AC power cord from the line when soldering. Turning the power switch OFF is not sufficient. Power-line leakage paths, through the heating element of the iron, may destroy transistors.

PARTS REMOVAL: If a part is not being returned for in-warranty factory replacement, it may be cut in half (with diagonal cutting pliers) to make removal easier. Multiple terminal parts, such as IF transformers, or electrolytic capacitors, should be removed using special de-soldering tips made especially for this purpose. Removing solder from terminals, reduces the possibility of breaking the printed circuit board when the part is removed.

ACCIDENTAL SHORTS: A clean working area, free of metal particles, screws, etc., is an important preventive in avoiding servicing problems. Screws, removed from the chassis during servicing, should be stored in a box until needed. While a set is operating, it takes only an instant for a base-to-collector short to destroy a transistor (and others direct-coupled to it). In the time it takes for a dropped machine screw, washer, or screwdriver, to contact a pair of socket terminals (or terminal and chassis), a transistor can be ruined.

SOLID-STATE DEVICES: Integrated Circuits contain the equivalent of many circuit parts, including transistors, diodes, resistors, and capacitors. The preferred troubleshooting procedure requires isolating the trouble to one stage using AC signal tracing methods. Once the suspected stage is located, the DC voltages at the input and output leads are measured to give an accurate indication of the operating conditions of the IC. DO NOT use an ohmmeter to check continuity with the IC mounted on the printed circuit board. Forward biasing the internal junctions within the IC may burn out the transistors. Do not replace a defective IC until all external resistors, capacitors, and transformers are checked first, to prevent the replacement IC from failing immediately due to a defect in the connecting components. Solder and unsolder each lead separately using a pliers or other heat sink on the lead to prevent damage from excessive heat. Check that the leads are

connected to the correct locations on the printed circuit board before turning the set on.

Whenever possible, a transistor tester should be used to determine the condition of a transistor or diode. Ohmmeter checks do not provide conclusive data, and may even destroy the junction(s) within the device.

Never attempt to repair a transistor power amplifier module until the power supply filter-capacitors are fully discharged.

If an output or driver transistor becomes defective (opens or shorts), always check ALL direct-coupled transistors and diodes in that channel. In addition, check the bias pot., and other parts in the bias network, before installing replacement transistors. All output and driver transistors in one channel may be destroyed if the bias network is defective. After parts replacement, always check the bias adjustment for specified idling current.

In some applications, replacement of transistors must be made from the same beta group as the original type. The beta group is indicated by a colored marking on the transistor. Be sure to include this information when ordering replacement transistors.

When mounting a replacement power transistor, be sure the bottom of the flange, mica insulator, and the surface of the heat sink, are free of foreign matter. Dust and grit will prevent flat contact, reducing heat transfer to the heat sink. Metallic particles can puncture the insulator, cause a short, and destroy the transistor.

Silicone grease must be used between the transistor and the mica insulator, and between the mica and the heat sink, for best heat transfer. Use Dow-Corning DC-3, or an equivalent compound made for power transistor heat conduction.

Use care when making connections to speakers and output terminals. To reduce the possibility of shorts, lugs should be used on the exposed ends, or stranded wire should be tinned to prevent frayed wire ends. Current in the speakers and output circuitry is quite high — poor contacts, or small sized wire, can cause significant power losses in the system. For wire lengths greater than 30 feet, 16 AWG, or heavier, should be used.

VOLTAGE MEASUREMENTS: All voltages are measured with the line voltage adjusted to 120 volts. All measured voltages are $\pm 10\%$. DC voltages are measured to ground with a VTVM, with no signal input unless otherwise noted. AC signal voltages are measured under the conditions specified on the schematic.

ALIGNMENT PROCEDURES: DO NOT attempt realignment unless the required test equipment is available, and the alignment procedure is thoroughly understood.

BECAUSE ITS PRODUCTS ARE SUBJECT TO CONTINUOUS IMPROVEMENT, FISHER RADIO RESERVES THE RIGHT TO MODIFY ANY DESIGN OR SPECIFICATION WITHOUT NOTICE AND WITHOUT INCURRING ANY OBLIGATION.

CHASSIS LAYOUT

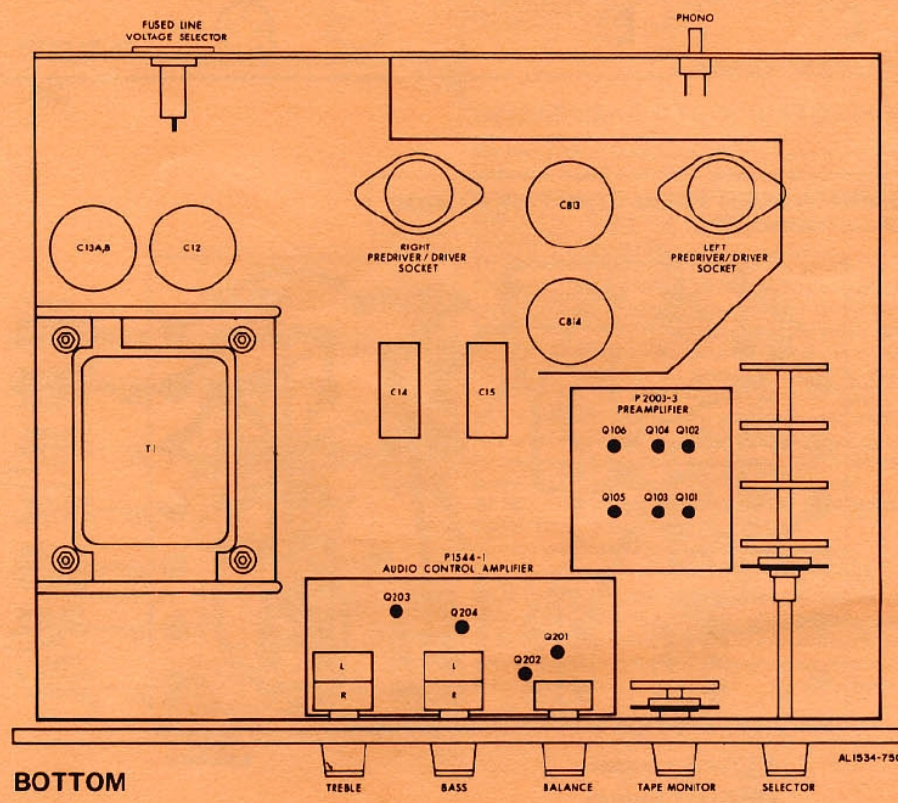
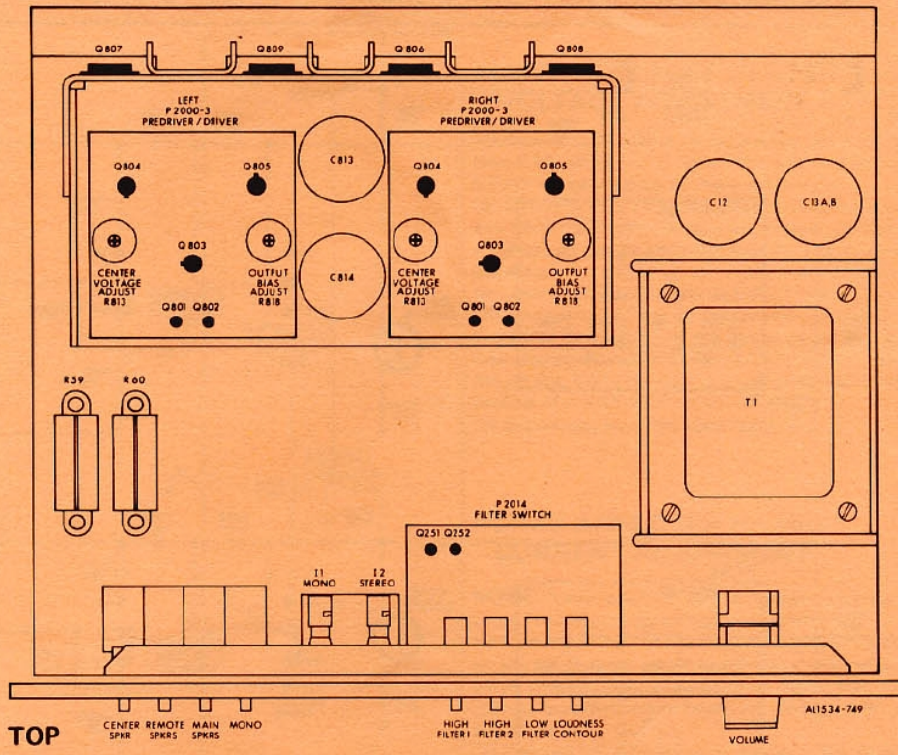

1544-1 AUDIO CONTROL AMPLIFIER

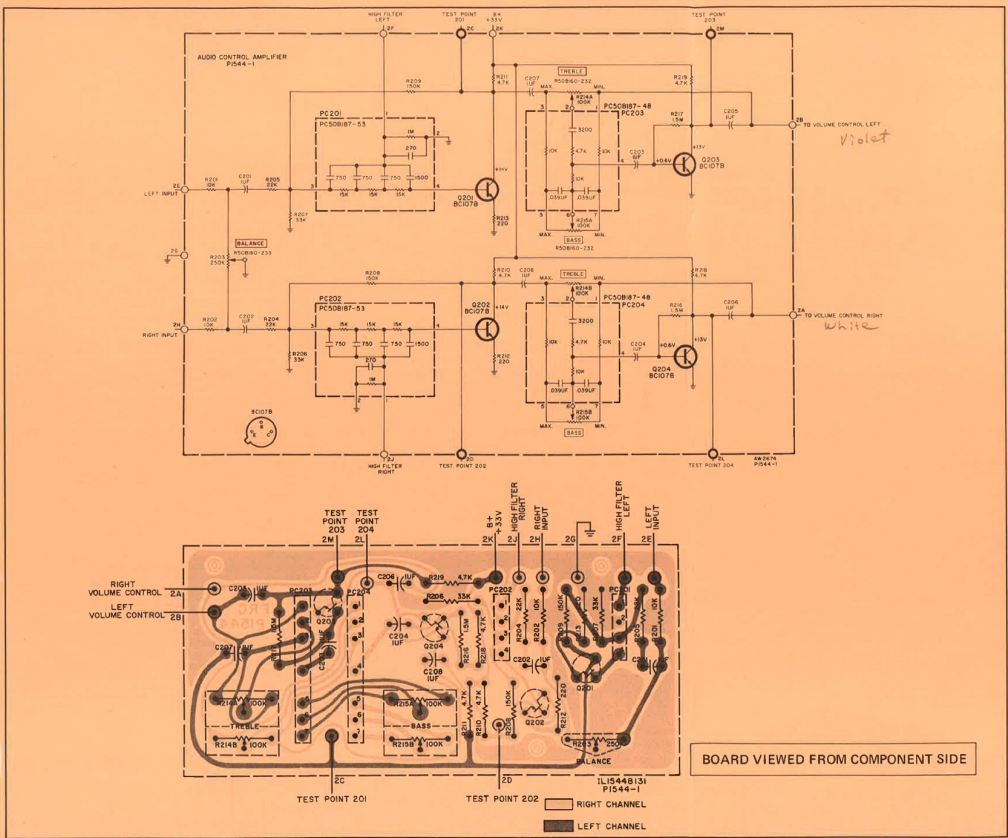

BOARD VIEWED FROM COMPONENT SIDE

POWER AMPLIFIER CENTER VOLTAGE ADJUSTMENT

- (1) Connect two 10K \pm 1% resistors in series across capacitor C12 (2500 μ F). Connect the common lead of a DC VTVM to the junction of the two resistors.
- (2) Connect DC VTVM to the junction of resistors R827 and R829 (0.82 ohm) on the left channel portion of the dual channel power amplifier module. Adjust Center Voltage Adjust Pot. R813 on left channel predriver/driver board for reading of 0 \pm 0.5 VDC on DC VTVM.
- (3) Connect DC VTVM to the junction of resistors R826 and R828 (0.82 ohm) on the right channel portion of the dual channel power amplifier module. Adjust Center Voltage Adjust Pot. R813 on right channel predriver/driver board for reading of 0 \pm 0.5 VDC on DC VTVM.
- (4) Disconnect two 10K ohm resistors.

POWER AMPLIFIER IDLING CURRENT ADJUSTMENT

- NOTE: Power amplifier center voltage adjustment must be performed before starting this procedure.
- (1) Connect DC VTVM across resistor R827 (0.82 ohm) on the left channel portion of the dual channel power amplifier module. Adjust Output Bias Adjust Pot. R818 on left channel predriver/driver board for reading of 40 \pm 10mV DC on DC VTVM.
 - (2) Connect DC VTVM across resistor R826 (0.82 ohm) on the right channel portion of the dual channel power amplifier module. Adjust Output Bias Adjust Pot. R818 on right channel predriver/driver board for reading of 40 \pm 10mV DC on DC VTVM.

INTERMODULATION DISTORTION TEST

- Set BALANCE, BASS and TREBLE controls to their center positions. Set SELECTOR switch to AUX 1 and TAPE MONITOR switch to STEREO. Push in MAIN SPKRS pushbutton. Check that MONO pushbutton is out. Unplug AC power cord.
- (1) Connect a 4-ohm, 50-watt resistor across the LEFT CHANNEL MAIN SPKR terminals. In parallel with the load resistor, connect the input leads of an IM (Intermodulation) distortion analyzer and the input leads of an AC VTVM capable of reading 0.1 volts with accuracy.
 - (2) Connect IM-analyzer generator output to the LEFT CHANNEL MON IN jack.
 - (3) Connect AC power cord and rotate VOLUME control to its maximum clockwise position—full volume.
 - (4) Increase IM-analyzer generator input to set for 30 watts output (9.0 VAC across 4-ohm load resistor).
- AFTER ONE FULL MINUTE OF WARM-UP TIME, PROCEED TO NEXT STEP.
- (5) IM meter reading should be 0.8% or less.
 - (6) Repeat preceding steps for right channel.
- NOTE: If any of the preceding instructions are different from those in the IM-analyzer instruction manual, it is best to follow those in the manual. If a load resistor of 50-watt rating is built into the IM analyzer, a separate load resistor is not required.

Left 0.67%
Right 0.86%

1/10/73

2160 DUAL CHANNEL POWER AMPLIFIER MODULE

SERVICE PROCEDURES

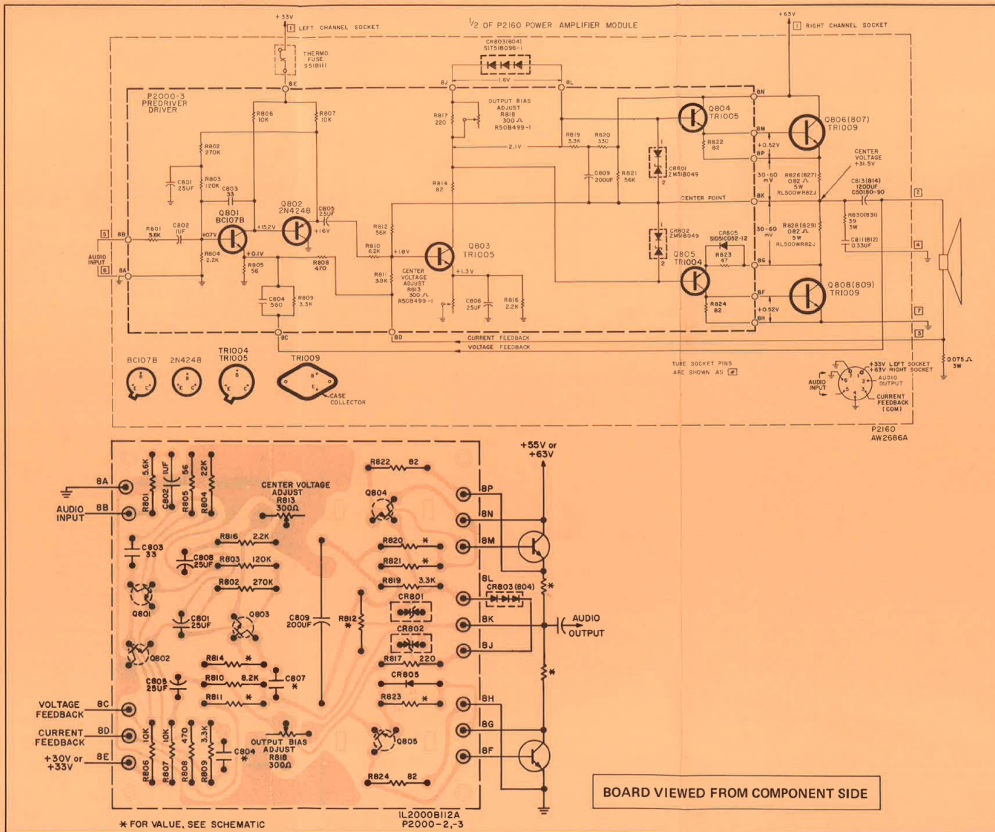

HARMONIC DISTORTION TEST

Set BALANCE, BASS and TREBLE controls to their center positions. Set SELECTOR switch to AUX 1 and TAPE MONITOR switch to STEREO. Push in MAIN SPKRS pushbutton. Check that MONO pushbutton is out. Unplug AC power cord.

- (1) Connect a 4-ohm, 50-watt resistor across the LEFT CHANNEL MAIN SPKR terminals. In parallel with the load resistor, connect the input leads of an harmonic distortion analyzer and the input leads of an AC VTVM capable of reading 0.1 volts with accuracy.
- (2) Connect a low-distortion audio sine wave generator, set for 1000 Hz (cps), to the LEFT CHANNEL MON IN jack.
- (3) Connect AC power cord and rotate VOLUME control to its maximum clockwise position—full volume.
- (4) Increase audio generator input to set for 45 watts output (13.4 VAC across 4-ohm load resistor). Harmonic distortion meter should read 0.5% or less.
- (5) Repeat preceding steps for right channel.

POWER OUTPUT MEASUREMENT

The output amplifier of this unit is designed to deliver its full-rated power with program material (voice or music) into 4- to 16-ohm loads for an indefinite period of time.

When a constant audio tone is used as a signal to measure the continuous RMS power output, the following precautions must be taken.

- (1) Measure the power output of one channel at a time.
 - (2) Limit the measurement period to 10 minutes with a load resistance between 4 and 16 ohms.
- WARNING:** If the power output of both channels must ever be measured simultaneously, use a load of 4 to 8 ohms per channel and limit measurements to a period not longer than 3 minutes for a 4-ohm load and not longer than 5 minutes for an 8-ohm load.

REPLACING MONO AND STEREO LAMPS

To replace the MONO and STEREO lamps, proceed as follows:

- (1) Unplug AC power cord.
- (2) Gently pull all knobs off the front panel control shafts. Remove the hex nuts from the control shafts.
- (3) Carefully pry off the small front panel nameplate. Loosen and remove the machine screw hidden behind the nameplate.
- (4) Remove the screws which hold the top cover to the chassis and lift off the top cover. Remove the nut which holds the left top side of the front panel. Lift off the panel.
- (5) Remove the fiberglass sleeve from the lamp.
- (6) Gently push in on the lamp and turn it counterclockwise to remove. Place the new lamp in the socket, push in gently and turn it clockwise to lock it in place.
- (7) Replace the fiberglass sleeve on the lamp.
- (8) Replace the front panel and secure it with the hex nuts removed previously. Replace the knobs on the control shafts.
- (9) Replace the nut which holds the left top side of the front panel. Replace the top cover on the chassis and secure with the screws removed previously.
- (10) Insert and tighten the machine screw in the hole behind the nameplate mount. Push the nameplate into the mounting holes on the front panel.

CLEANING FRONT PANEL

WARNING: Use only plain lukewarm water and a freshly laundered, soft lint-free cloth to clean the front control panel.

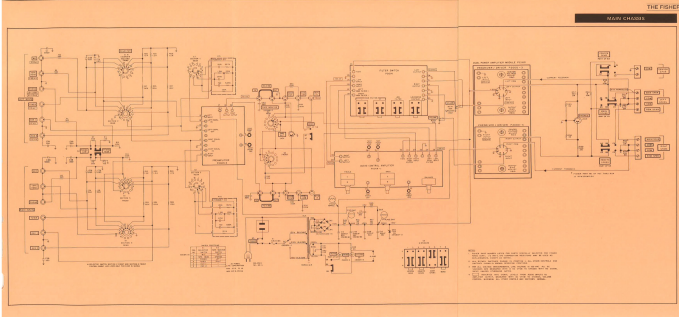

- 1. RESISTORS ARE 5% TOLERANCE UNLESS OTHERWISE SPECIFIED
- 2. CAPACITORS ARE 5% TOLERANCE UNLESS OTHERWISE SPECIFIED
- 3. ALL CAPACITORS ARE POLYESTER UNLESS OTHERWISE SPECIFIED
- 4. ALL VACUUM TUBES ARE 6X4 PENTODES UNLESS OTHERWISE SPECIFIED

2003-3 PREAMPLIFIER

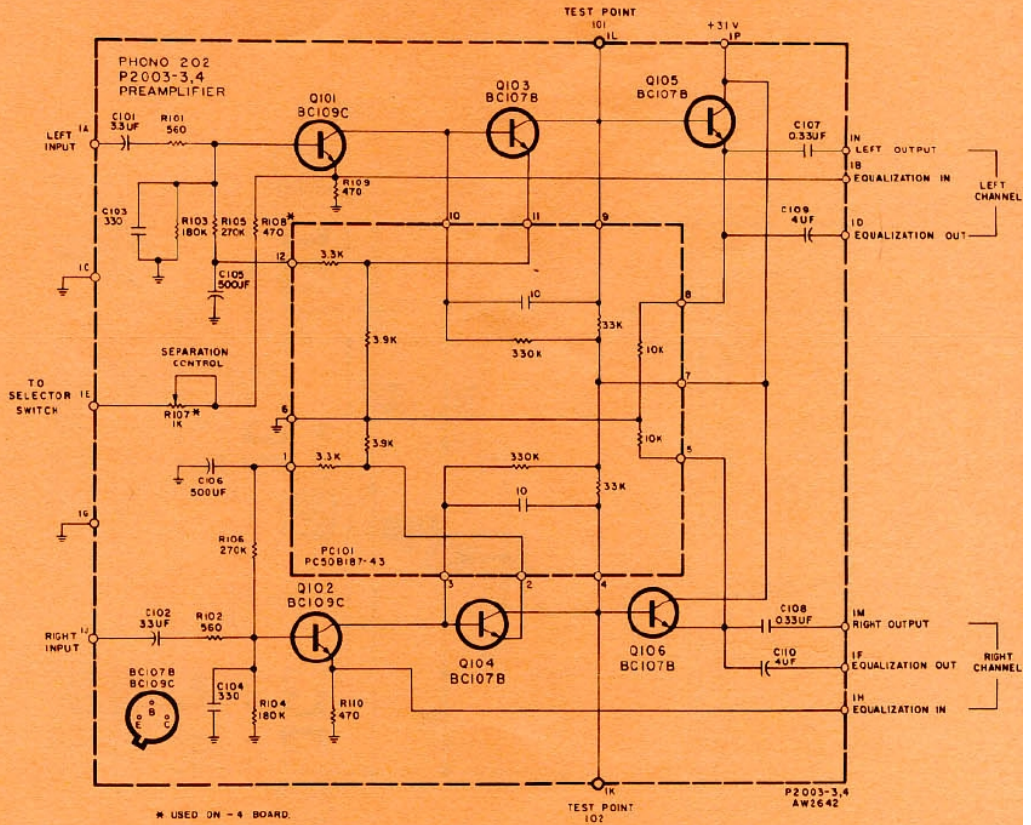

BOARD VIEWED FROM COMPONENT SIDE

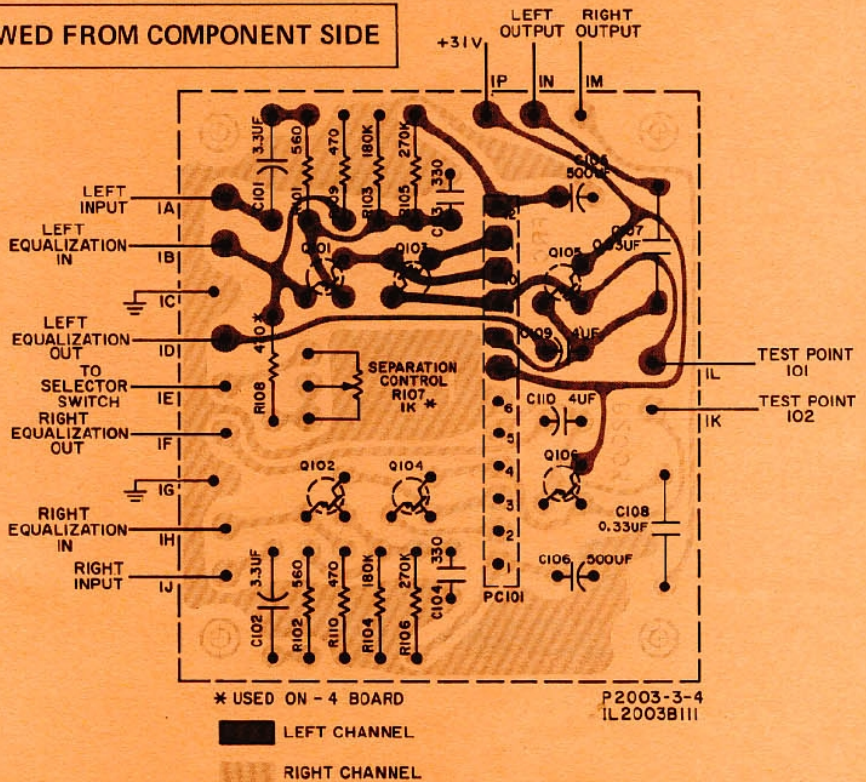

COMPONENT CONNECTIONS

