

This Manual Also Covers Model 1800

# Service Manual

# THE FISHER®

LAST FILE COPY  
DO NOT REMOVE

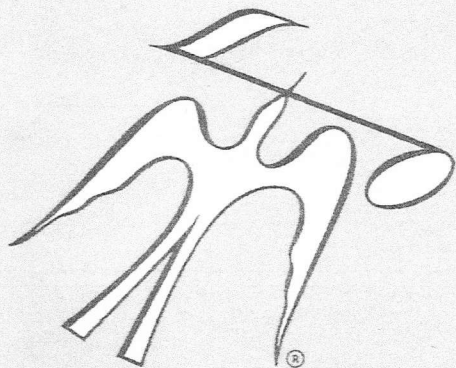
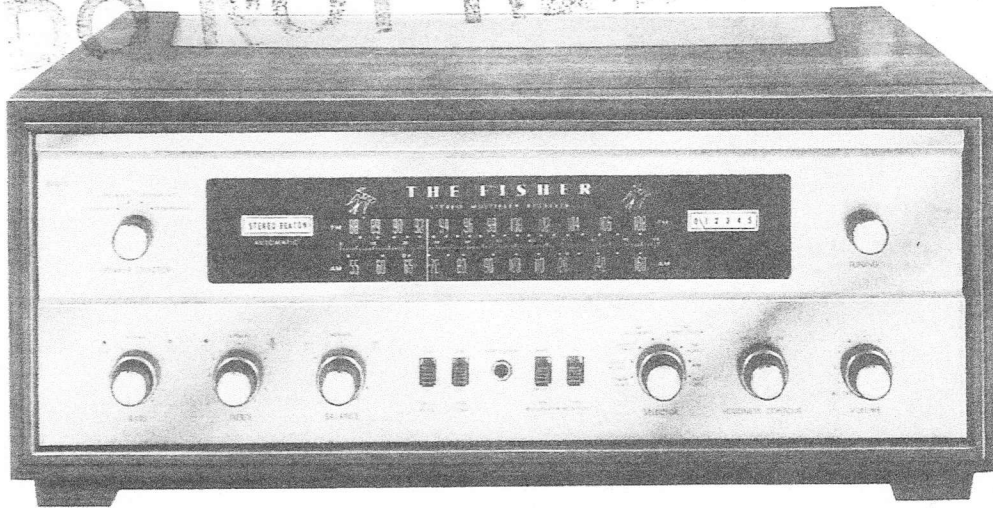

# 800-C

CHASSIS SERIAL NUMBERS  
BEGINNING 51501

FISHER RADIO CORPORATION • LONG ISLAND CITY 1 • NEW YORK

# PARTS DESCRIPTION LIST

## CAPACITORS

10% tolerance for all fixed capacitors, unless otherwise noted or marked GMV (guaranteed minimum value). All capacitors not marked uf are Pf (uuf).

Symbol	Description	Part No.
C1	Ceramic, 47, 5%, N750, 1000V	C50070-29
C2	Ceramic, 1, 20%, P100, 1000V	C50070-1
C3	Ceramic, 1000, GMV, 500V	C50089-2
C4, 5, 6	Ceramic, Feedthru, 1000, GMV	C592-187
C7	Ceramic, 7, 5%, NPO, 1000V	C50070-20
C8	Ceramic, .02uf, +80 -20%, 100V	C50073-1
C9	Ceramic, 1000, GMV, 500V	C50089-2
C10	Ceramic, 7, ±.5, NPO, 500V	CC20CJ070D5
C11	Ceramic Trimmer	C662-123
C12	Variable, FM-AM	C965-115
C13	Ceramic, .02uf, +80 -20%, 500V	C50089-4
C14, 15	Ceramic, 18, N470, 1000V	C50070-13
C16	Mylar, .047uf, 630V	C50197-101
C17	Mylar, .047uF, 400V	C50197-30
C18	Mylar, .047uf, 630V	C50197-101
C19	Mylar, .047uf, 400V	C50197-30
C20	Ceramic, .68, 500V	C50077-6N
C21, 22	Ceramic, 820, 1000V	C500072-7
C23	Ceramic Trimmer	C662-123
C24	Ceramic, 8, ±.5, NPO, 500V	CC20CJ080D5
C26	Ceramic, 5000, 20%, 500V	C50089-1
C27	Ceramic, 68, N750, 500V	CC20UJ680K5
C28	Ceramic, .02uf, +80 -20%, 500V	C50089-4
C29	Ceramic, 100, 5%, N1500, 1000V	C50070-19
C30, 31	Ceramic, 100, N1500, 1000V	C50070-6
C32	Ceramic Trimmer	C50B792-1
C33	Ceramic, 24, 5%, N150, 1000V	C50070-8
C34	Ceramic, 8, ±.5, N330, 500V	CC20SJO80D5
C35	Ceramic, 1000, 1000V	C50072-3
C36	Ceramic, 68, N2200, 1000V	C50070-12
C37	Ceramic, 6, 5%, NPO, 1000V	C50070-43
C38	Ceramic, .02uf, +80 -20%, 100V	C50073-1
C39	Ceramic, 68, N2200, 1000V	C50070-12
C40, 41	Ceramic, .02uf, 20%, 500V	C50089-5
C42, 43	Ceramic, Feedthru, 1000, GMV	C592-187
C44	Mylar, .047uf, 400V	C50197-30
C45	Ceramic, 820, 1000V	C50072-7
C46	Mylar, .047, 400V	C50197-30
C47	Ceramic, 820, 1000V	C50072-7
C48	Ceramic, .02, +80 -20%, 100V	C50073-1
C49	Mylar, .047uf, 250V	C50197-52
C50	Ceramic, 100, N1500, 1000V	C50070-6
C51	Ceramic, 2700, 1000V	C50072-17
C52, 53	Ceramic, 5000, +80 -20%, 500V	C50089-6
C54, 55	Ceramic, 100, 5%, N1500, 1000V	C50070-19
C56	Ceramic, 1, 20%, P100, 1000V	C50070-1
C57	Ceramic, .02uf, 20%, 500V	C50089-5
C58	Ceramic, 150, 1000V	C50072-18
C59	Ceramic, 5000, +80 -20%, 500V	C50089-6
C60	Mylar, .1uf, 125V	C50435-7
C61	Ceramic, 2700, 1000V	C50072-17
C62	Ceramic, .02uf, GMV, 1000V	C50071-6
C63	Ceramic, 5000, +80 -20%, 500V	C50089-6
C64	Mylar, .1uf, 125V	C50435-7
C65	Electrolytic, 2uf, 70V	C721-142
C66	Polystyrene, 1800, 5%, 125V	CP50394-11
	* Polystyrene, 1200, 5%, 125V	CP50394-25
C67	Electrolytic, .5uf, 350V	C50283-7
C68	Ceramic, .02uf, 20%, 500V	C50089-5
C69	Ceramic, 2200, 1000V	C50072-5
C70	Ceramic, .02uf, 20%, 500V	C50089-5
C71	Ceramic, 2200, 1000V	C50072-5
C72	Ceramic, 24, 5%, N150, 1000V	C50070-8
C73	Mylar, .1uf, 125V	C50435-7
C74	Ceramic, .02uf, +80 -20%, 100V	C50073-1
C75, 76	Ceramic, 1000, 1000V	C50072-3
C77, 78	Ceramic, 120, N1500, 1000V	C50070-9
C79, 80	Ceramic, 24, 5%, N150, 1000V	C50070-8
C81	Ceramic, 2700, 1000V	C50072-17
C82, 83, 84, 85, 86	Ceramic, 5000, +80 -20%, 500V	C50089-6
C87	Electrolytic, 4 Section: A — 20uf, 300V	C50180-49

B — 40uf, 400V  
C — 40uf, 450V  
D — 40uf, 500V

C88, 89, 90	Ceramic, 5000, +80 -20%, 500V	C50089-6
C91	Electrolytic, 4 Section: A — 50uf, 250V B — 50uf, 250V C — 50uf, 250V D — 200uf, 250V	C50180-48
C92	Mylar, .1uf, 125V	C50435-7
C93, 94	Ceramic, 5000, +80 -20%, 500V	C50089-6
C95	Electrolytic, 2 Section: A — 1000 uf, 35V B — 1000 uf, 35V	C50180-38
C96	Ceramic, 560, 1000V	C50072-14
C97	Ceramic, 2700, 1000V	C50072-17
C98	Electrolytic, 200uf, 250V	C50180-20
C99	Mylar, .022uf, 400V	C50B574-8
C100	Ceramic, 5000, +80 -20%, 500V	C50089-6
C101	Mylar, .022uF, 400V	C50B574-8
C102	Ceramic, .02uf, GMV, 1000V	C50071-6
C103	Ceramic, Feedthru, 1000, GMV	C592-187
C104	Molded, .01uf, 20%, 600V	C2747
C105, 106	Ceramic, .01uf, 20%, 500V	C50089-3
C107, 108, 109	Ceramic, 330, 1000V	C50072-1
C110	Molded, .01uf, 20%, 600V	C2747
C111	Electrolytic, 8uf, 50V	C629-138
C112, 113	Ceramic, 100, GMV, N1500, 1000V	C50070-5
C116, 117	Electrolytic, 50uf, 35V	C50483-4
C118	Ceramic, .01uF, 20%, 500V	

## RESISTORS & POTENTIOMETERS

In ohms, 5% tolerance, 1/8 Watt, unless otherwise noted. K=Kilohms, M=Megohms.

Symbol	Description	Part No.
R1	Wirewound, 25, 10%, 5W	R688-117
R2	Composition, 270, 10%, 1/2 W	RC20BF271K
R3	Composition, 100K, 10%, 1/2 W	RC20BF104K
R4	Composition, 330, 10%, 1W	RC20BF331K
R6	Wirewound, 25, 10%, 5W	R688-117
R8	Composition, 330, 10%, 1W	RC30BF331K
R9	Dep. Carbon, 47	R12DC470J
R10	Dep. Carbon, 1K	R12DC102J
R11	Composition, 3.3, 10%, 1/2 W	RC20BF3R3K
R12	Dep. Carbon, 100K	R12DC104J
R13	Dep. Carbon, 1M, 1/2 W	R33DC105J
R14	Composition, 100, 10%, 1/2 W	RC20BF101K
R15	Dep. Carbon, 1.8M, 1/2 W	R33DC185J
R16	Composition, 47K, 10%, 1/2 W	RC20BF473K
R17, 18, 19, 20	Dep. Carbon, 1K, 1/2 W	R33DC102J
R21, 22, 23, 24, 25	Dep. Carbon, 330K	R12DC334J
R26	Dep. Carbon, 180K, 1/2 W	R33DC184J
R27	Dep. Carbon, 2.2K, 1/2 W	R33DC222J
R28	Dep. Carbon, 180K, 1/2 W	R33DC184J
R29	Dep. Carbon, 2.2K, 1/2 W	R33DC222J
R30, 31	Dep. Carbon, 68K, 1/2 W	R33DC683J
R32	Dep. Carbon, 22K	R12DC223J
R33, 34	Dep. Carbon, 33K, 1/2 W	R33DC333J
R35	Dep. Carbon, 2.2K, 1/2 W	R33DC222J
R36	Dep. Carbon, 220, 1/2 W	R33DC221J
R37	Dep. Carbon, 2.2K, 1/2 W	R33DC222J
R38	Dep. Carbon, 220, 1/2 W	R33DC221J
R39, 40	Potentiometer, 25K, Phase Inverter Adj.	R50103-2
R41	Composition, 18K, 10%, 1W	RC30BF183K
R42, 43	Dep. Carbon, 470K, 1/2 W	R33DC474J
R44	Dep. Carbon, 470K	R12DC474J
R45, 46	Dep. Carbon, 47K	R12DC473J
R47	Potentiometer, 500K, Dual Volume	R50160-104
R48	Dep. Carbon, 27	R12DC270J
R49	Dep. Carbon, 2.7K	R12DC272J
R50, 51	Dep. Carbon, 270	R12DC271J

# PARTS DESCRIPTION LIST

<p>R52 Composition, 1K, 10%, 1/2 W  R53 Composition, 2.7K, 10%, 1/2 W  R54, 55 Dep. Carbon, 22K  R56 Composition, 1K, 10%, 1/2 W  R57 Potentiometer, 300K, Dual Balance  R58 Dep. Carbon, 56K  R59, 60 Dep. Carbon, 2.7M, 1/2 W  R61, 62 Dep. Carbon, 120K, 1/2 W  R63, 64 Dep. Carbon, 1K, 1/2 W  R65 Composition, 180, 10%, 1/2 W  R66 Dep. Carbon, 3.3M, 1/2 W  R67 Dep. Carbon, 39K  R68 Dep. Carbon, 1K  R69 Composition, 27K, 10%, 1/2 W  R70 Composition, 1K, 10%, 1/2 W  R71 Dep. Carbon, 39K  R72 Composition, 10K, 10%, 1/2 W  R73 Composition, 100, 10%, 1/2 W  R74, 75 Dep. Carbon, 220K  R76 Dep. Carbon, 82K  R77, 78 Dep. Carbon, 680K  R79, 80 Potentiometer, 500K,  Dual Bass, Treble  R81 Dep. Carbon, 680K  R82 Dep. Carbon, 150K  R83 Dep. Carbon, 820K  R84 Composition, 150, 10%, 1/2 W  R85 Dep. Carbon, 470K  R86 Dep. Carbon, 270K  R87 Composition, 47K, 10%, 1/2 W  R88 Dep. Carbon, 47K  R89 Dep. Carbon, 820K  R90 Composition, 1K, 10%, 1/2 W  R91 Dep. Carbon, 820K  R92 Dep. Carbon, 56K  R93, 94 Dep. Carbon, 820K  R95 Dep. Carbon, 68K  R96 Dep. Carbon, 120K, 1/2 W  R97 Dep. Carbon, 1K, 1/2 W  R98 Dep. Carbon, 120K, 1/2 W  R99 Dep. Carbon, 1K, 1/2 W  R100 Dep. Carbon, 2.2M, 1/2 W  R101 Composition, 220, 10%, 1/2 W  R102 Dep. Carbon, 2.7M, 1/2 W  R103 Dep. Carbon, 1.5M, 1/2 W  R104 Dep. Carbon, 2.7M, 1/2 W  R105 Dep. Carbon, 1.5M, 1/2 W  R106 Composition, 220, 10%, 1/2 W  R107, 108 Dep. Carbon, 470K  R109, 110 Dep. Carbon, 330K  R111 Dep. Carbon, 22K  R112 Composition, 100, 10%, 1/2 W  R113 Composition, 82K, 10%, 1/2 W  R114 Composition, 1K, 10%, 1/2 W  R115 Composition, 82K, 10%, 1/2 W  R116 Dep. Carbon, 47K  R117 Composition, 22K, 10%, 1/2 W  R118 Dep. Carbon, 180  R119 Dep. Carbon, 8.2K, 1/3W  R120 Composition, 2.7K, 10%, 1W  R121 Glass, 470, 10%, 3W  R122 Dep. Carbon, 27K, 1/3W  R123 Composition, 1.2K, 10%, 1W  R124 Dep. Carbon, 820K  R125, 126 Dep. Carbon, 82K  R127 Wirewound, 15, 10%, 5W  R128 Glass, 1.2K, 10%, 7W  R129 Glass, 470, 10%, 3W  R130 Dep. Carbon, 330K  R131 Composition, 68K, 10%, 1/2 W  R132 Dep. Carbon, 330K  R135, 136 Dep. Carbon, 4.7M, 1/2 W  R137 Composition, 1K, 10%, 1/2 W  R138 Composition, 270, 1/2W  R139, 140 Dep. Carbon, 220K, 1/2 W  R141, 142 Glass, 330K, 1W  R143 Dep. Carbon, 10K  R144 Glass, 2.7K, 1/2 W  R145 Dep. Carbon, 10K  R146 Glass, 2.7K, 1/2 W</p>	<p>RC20BF102K  RC20BF272K  R12DC223J  RC20BF102K  R50160-130  R12DC563J  R33DC275J  R33DC124J  R33DC102J  RC20BF181K  R33DC335J  R12DC393J  R12DC102J  RC20BF273K  RC20BF102K  R12DC393J  RC20BF103K  RC20BF101K  R12DC224J  R12DC823J  R12DC684J  R50160-101-2  R12DC684J  R12DC154J  R12DC824J  RC20BF151K  R12DC474J  R12DC274J  RC20BF473K  R12DC473J  R12DC824J  RC20BF102K  R12DC824J  R12DC563J  R12DC824J  R12DC683J  R33DC124J  R33DC102J  R33DC124J  R33DC102J  R33DC225J  RC20BF221K  R33DC275J  R33DC155J  R33DC275J  R33DC155J  RC20BF221K  R12DC474J  R12DC334J  R12DC223J  RC20BF101K  RC20BF823K  RC20BF102K  RC20BF823K  R12DC473J  RC20BF223K  R12DC180J  R33DC822J  RC30BF272K  RPG3W471K  R12DC273J  RC30BF122K  R12DC824J  R12DC823J  R719-106  RPG7W122K  RPG3W471K  R12DC334J  RC20BF683K  R12DC334J  R33DC475J  RC20BF102K  RC20BF271J  R33DC224J  R30G334J  R12DC103J  R20G272J  R12DC103J  R20G272J</p>	<p>R147 Composition, 820K, 10%, 1/2 W  R148 Dep. Carbon, 100K  R149 Dep. Carbon, 10  R150 Dep. Carbon, 100K  R151 Dep. Carbon, 10  R152 Composition, 1.5K, 1/2W  R153 Composition, 1K, 1/2W  R154 Dep. Carbon, 15K, 1/2 W  R155 Dep. Carbon, 150K  R156 Dep. Carbon, 68K  R157 Dep. Carbon, 150K  R158 Dep. Carbon, 68K  R159, 160 Dep. Carbon, 220K</p>	<p>RC20BF824K  R12DC104J  R12DC100J  R12DC104J  R12DC100J  RC20BF152J  RC20BF102J  R33DC153J  R12DC154J  R12DC683J  R12DC154J  R12DC683J  R12DC224J</p>
<b>COILS, CHOKES &amp; TRANSFORMERS</b>			
<b>Symbol</b>	<b>Description</b>	<b>Part No.</b>	
L1	FM Antenna Coil	L965-119	
L2	AM Ferrite Loop Antenna	L50695	
L3	Choke, Ferrite Bead	L592-189	
L4	Choke, 1.5 Microhenry	L50066-4	
L5	AM-RF Transformer	L50210-35	
L6	FM-RF Coil	L965-116	
L7	FM Mixer Coil	L965-117	
L8	Choke, 1 Microhenry	L50066-2	
L9	AM Oscillator Coil	L50210-28	
L10	Choke, 1 Microhenry	L50066-2	
L11	FM Oscillator Coil Assembly	AS965-120	
L12, 13, 14	Choke, 1 Microhenry	L50066-2	
L16 thru 27	Choke, Filament, Ferrite Bead	L592-189	
L28	Choke, 3.3 Microhenries	L50066-8	
T1	Transformer, Power	T991-115	
---	Transformer, Power	TX991C115	
T2	Transformer, Output	T991-116-1	
T3	Transformer, Output	T991-116-2	
Z1	Transformer, AM, IF	ZZ50210-41	
Z2	Transformer, FM, IF	ZZ50210-42	
Z3	Transformer, FM, IF	ZZ50210-39	
Z4	Transformer, AM, IF	ZZ2984	
Z5	Transformer, FM, IF	ZZ50210-2	
Z6	FM Limiter Coil	ZZ50210-6	
Z7	FM Ratio Detector	ZZ50210-9	
<b>MISCELLANEOUS</b>			
<b>Symbol</b>	<b>Description</b>	<b>Part No.</b>	
---	FM Front End	P965-1	
---	Multiplex Decoder	P1007-4	
CR1	Diode, 1N38	V1N38	
CR2, 3, 4, 5	Diode, Silicon	V50260-10	
CR6, 7	Diode, Silicon	SR50411-1	
---	Fuse, 3.2A Slo-Blo	F3319	
---	Fuse, 1.5A Slo-Blo	F3319-12	
I1	Lamp, #47 OF	I50009-8	
I2, 3	Lamp, Dial	I50441-4	
I4	Lamp, #47 OF, Stereo Beacon	I50009-8	
J1	Headphone Jack	J846-120-1	
M1	Meter, Tuning	M990-124	
PC1	Printed Circuit	PC50434	
PC2, 3	Printed Circuit, High Filter	PC50187-2	
PC4, 5	Printed Circuit, Tone Control	PC50187-9	
PC6, 7	Printed Circuit, Equalization	PC50187-3	
RLT	Relay	K50314	
S1	Switch, Selector	S990-131BX	
S2	Switch, Slide, AM Bandwidth	S50200-5	
S3	Switch, Speaker Selector	S990-130	
S4	Switch, Loudness Contour	S990-129	
S5, 6, 7	Switch, Slide	S50200-5	
S8	Switch, Power	part of R47	
SR1	Selenium Rectifier, Bridge	SR50253-1	
---	FM Dipole Assembly	AS50227-1	
---	Dress Panel	AS990-108	
---	Dress Panel Assembly	AS1554A116	
---	Knob, Dummy Dual	E50324	
---	Knob, Dual, Rear	E50221	
---	Knob, Dual, Front	E50323	
---	Knob, Tuning	E50325-2	
---	Knob, Speaker Selector	E50325-2	
---	Dial Glass	N990-107	
---	Dial Glass	N1554C114	
---	Fuse Holder	X563-551	

\*Used on Model 1800 only.

# ALIGNMENT INSTRUCTIONS

## Read These Instructions With Extreme Care Before Attempting Alignment.

**CHASSIS:** Turn the station selector completely counterclockwise, without forcing. Dial pointer should be at zero index mark on logging scale. If not, reset the dial pointer. Disconnect the external antennas and the antenna link. Set Ferrite loop to normal position, parallel to rear panel. When using an oscilloscope for alignment, set the output level controls for no overload, as shown by the proper waveform shape. Connect loads to main output and turn volume control to minimum.

**SIGNAL GENERATORS:** The signal generator equipment must be able to supply the following: FM RF modulated 30% ( $\pm 22.5$  KC deviation) at 400 cps; AM RF modulated 30% at 400 cps;

AM IF with 30KC sweep for AM bandwidth adjustment.

**INDICATOR:** DC VTVM, AC VTVM, and scope for alignment.

**ALIGNMENT:** Allow the chassis and test instruments to warm up for at least fifteen minutes. Adjust the line voltage for 117 volts AC, 50-60 cycles. Use fully insulated tools: a small screw-driver for all trimming capacitors; a K-Tran tool for Z1, Z2, Z3, Z4, Z5; a hex tool for L1, L5, L6, L7, L9, L11, Z6 and Z7. For AM alignment, short AVC lead to ground.

## AM ALIGNMENT

**NOTE: For calibrating both the AM and FM, use as low an output voltage as possible from your signal generator.**

STEPS	CHASSIS		SIGNAL GENERATOR			INDICATOR		ALIGNMENT		
	AM BANDWIDTH	SELECTOR	STATION SELECTOR	COUPLING	FREQ.	MOD.	TYPE	CONNECTION	ADJUST	INDICATION
1	SHARP	AM	Point of no signal and no interference	AM Gen. connected thru .01-uf cap. in series with hot lead to VB, Pin 7	455 KC	30% AM at 400 cps	AC VTVM	to Left Rec. Output	Z1, Z4 top and bottom	Maximum voltage
2	BROAD	AM	Point of no signal and no interference	AM Gen. connected thru .01-uf cap. in series with hot lead to VB, Pin 7	455 KC	30 KC sweep	Scope	to Left Rec. Output	Z4 bottom	Adjust slightly for symmetrical curve
3	SHARP	AM	600 KC	AM Gen. connected thru 220-uf to the AM antenna terminal. Disconnect link between terminals.	600 KC	30% AM at 400 cps	AC VTVM	to Left Rec. Output	L9, L5, L2	Maximum voltage
4	SHARP	AM	1400 KC	AM Gen. connected thru 220-uf to the AM antenna terminal. Disconnect link between terminals.	1400 KC	30% AM at 400 cps	AC VTVM	to Left Rec. Output	C12J, C12G, C12E	Maximum voltage
5	Repeat steps 3 and 4 for proper dial calibration and maximum output.									
6		FM	Point of no signal and no interference	FM Gen. connected to ungrounded tube shield of V2	10.7 MC	None	DC VTVM	to test point 3	Z2, Z3, Z5, Z6, Z7, top and bottom	Maximum negative voltage
7		FM	Point of no signal and no interference	FM Gen. connected to ungrounded tube shield of V2	10.7 MC	None	Connect hot lead of DC VTVM to TSP4, ground to junction of resistors (47K) connected in series from TSP3 to GND.		Z7, top	Zero reading on zero center scale
8		FM	90 MC	FM Gen. connected thru two 120-ohm carbon resistors in series with lead to antenna terminals Normal.	90 MC	30% FM (22.5 KC Dev.) at 400 cps	DC VTVM	to TSP3 and scope to Left Rec. output	L11, L7, L6, L1	Check for sine waveform and adjust for maximum negative voltage
9		FM	106 MC	FM Gen. connected thru two 120-ohm carbon resistors in series with lead to antenna terminals Normal.	106 MC	30% FM (22.5 KC Dev.) at 400 cps	DC VTVM	to TSP3 and scope to Left Rec. output	C32, C23, C11	Check for sine waveform and adjust for maximum negative voltage
10	Repeat steps 8 and 9 for proper dial calibration and maximum output.									

## FM ALIGNMENT

# SCHEMATIC DIAGRAM

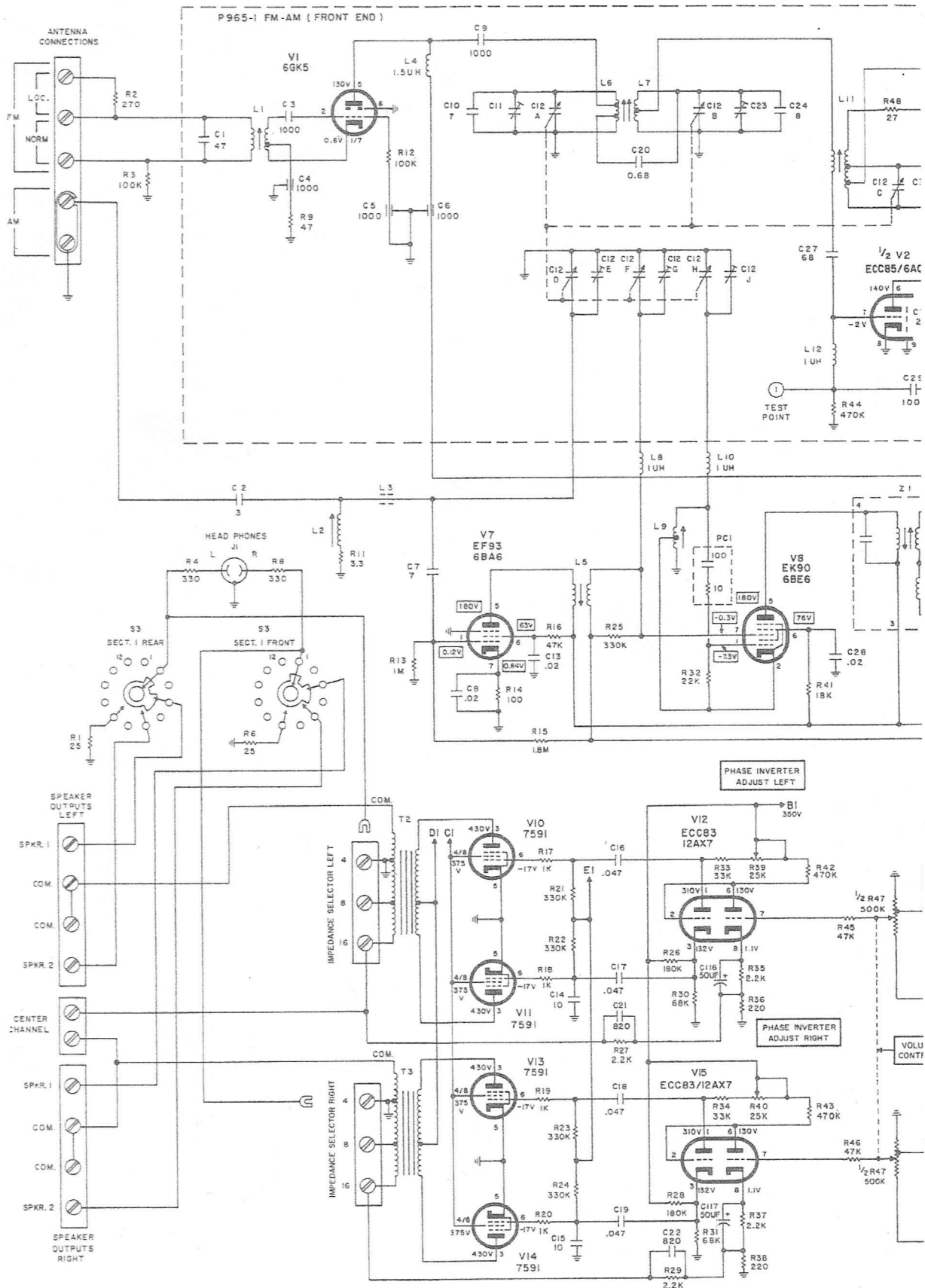

BECAUSE ITS PRODUCTS ARE SUBJECT TO CONTINUOUS IMPROVEMENT, FISHER RADIO CORPORATION RESERVES THE RIGHT TO MODIFY ANY DESIGN OR SPECIFICATION WITHOUT NOTICE AND WITHOUT INCURRING ANY OBLIGATION.

LEAD LOCATIONS (SEE NOTE 41)    D1    C1    E1    B1

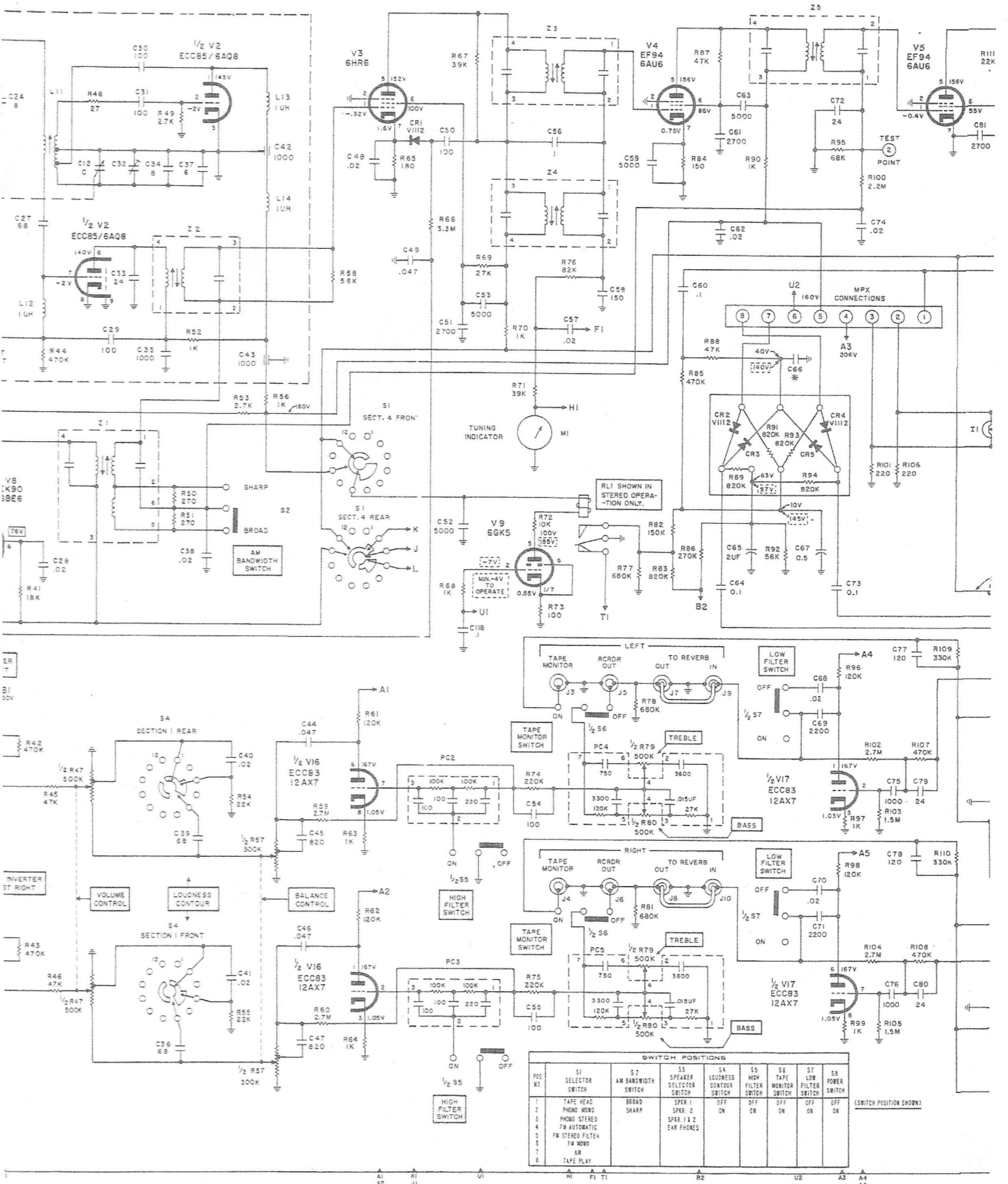

**SWITCH POSITIONS**

POS NO	S1 SELECTOR SWITCH	S2 AM BANDWIDTH SWITCH	S3 SPEAKER SELECTOR SWITCH	S4 LOUDNESS CONTOUR SWITCH	S5 HIGH FILTER SWITCH	S6 TAPES MONITOR SWITCH	S7 LOW FILTER SWITCH	S8 POWER SWITCH
1	TAPE HEAD	BROAD	SPER. 1	OFF	OFF	OFF	OFF	OFF
2	PHONO MONO	SHARP	SPER. 2	ON	ON	ON	ON	ON
3	PHONO STEREO		SPER. 1 & 2					
4	FM AUTOMATIC		EAR PHONES					
5	FM STEREO FILTER							
6	FM WOOD							
7	AR							
8	TAPE PLAY							

(SWITCH POSITION SHOWN)



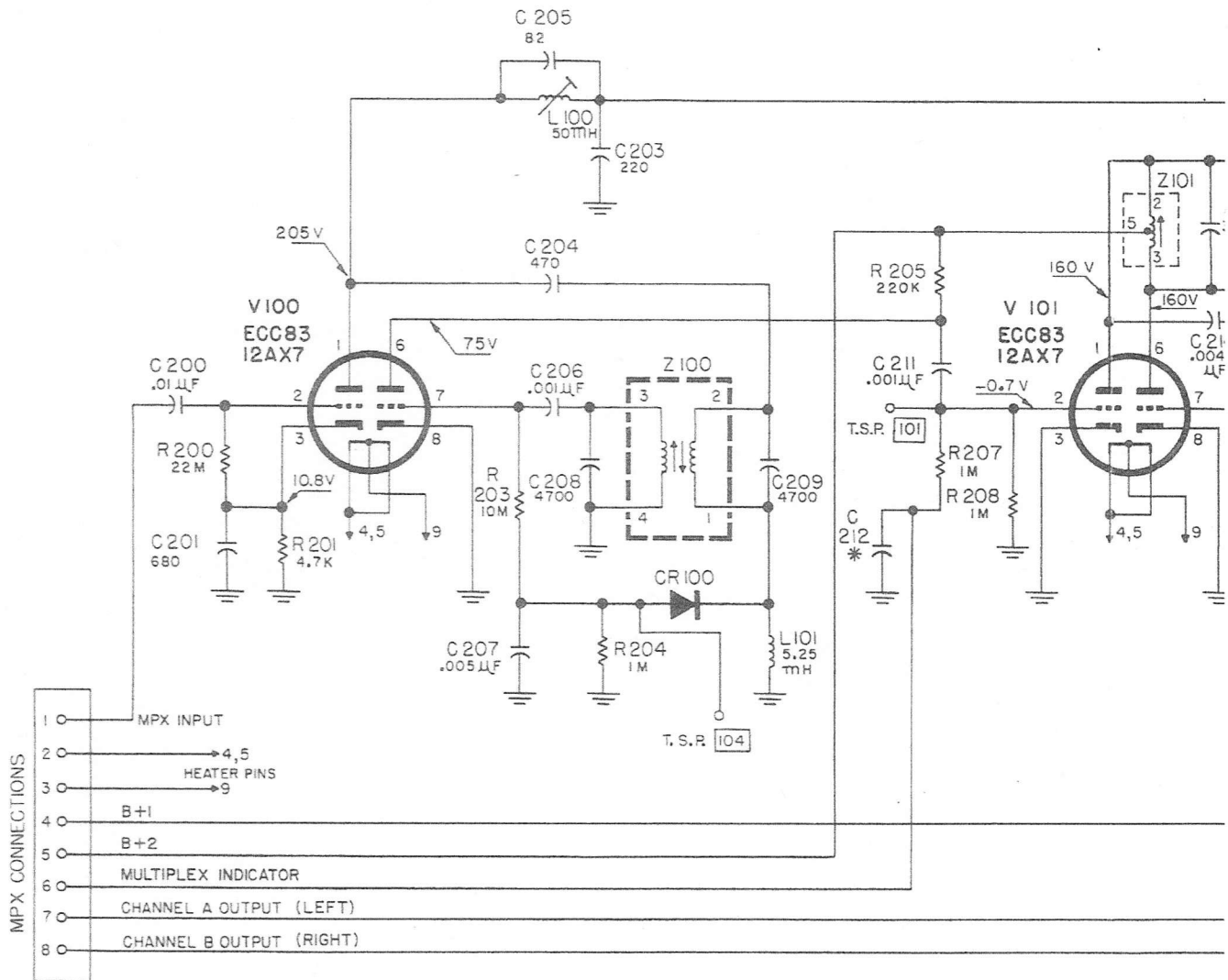

\* SEE PARTS LIST

# 1007-4 MULTI

## CAPACITORS

10% tolerance for all fixed capacitors, unless otherwise noted or marked GMV (guaranteed minimum value). All capacitors not marked uf are pF (uuf).

Symbol	Description	Part No.
C200	Ceramic, .01uf, +80 -20%, 500V	C50089-7
C201	Ceramic, 680, 1000V	C50072-2
C203	Ceramic, 220, 1000V	C50183-3
C204	Polystyrene, 470, 5%, 500V	C50394-1
C205	Ceramic, 82, 1000V	C50070-1
C206	Ceramic, 1000, GMV, 500V	C50089-2
C207	Ceramic, 5000, +80 -20%, 500V	C50089-6
C208, 209	Mica, 4700, 5%, 500V	C50332-5
C210	Electrolytic, 1uf, 350V	C50283-3
C211	Ceramic, 1000, GMV, 500V	C50089-2

C212	Ceramic, 5000, 20%, 500V	C50089-1
	*Ceramic, .05uF, +80% -20%	C50373-2
C214	Mylar, 4700, 400V	C50197-104
C215	Mica, 3900, 5%, 500V	C50332-6
C216, 217	Ceramic, 1000, GMV, 500V	C50089-2
C218	Ceramic, .02uf, 20%, 500V	C50089-5
C219	Ceramic, 330, 1000V	C50183-5
C220	Ceramic, .02uf, 20%, 500V	C50089-5
C221, 222	Mylar, .047uf, 250V	C50197-103
C223, 224	Ceramic, 1000, 1000V	C50072-3
C225, 226	Ceramic, 2200, 1000V	C50072-5
	**Ceramic, 1500, 1000V	C50072-10

\*Model 400 only

## RESISTORS

\*\*Model 1800 only

In ohms, 5% tolerance, 1/8 W unless otherwise noted. K=Kilohms, M=Megohms.

Symbol	Description	Part No.
R200	Composition, 22M, 10%, 1/2 W	RC20BF226K

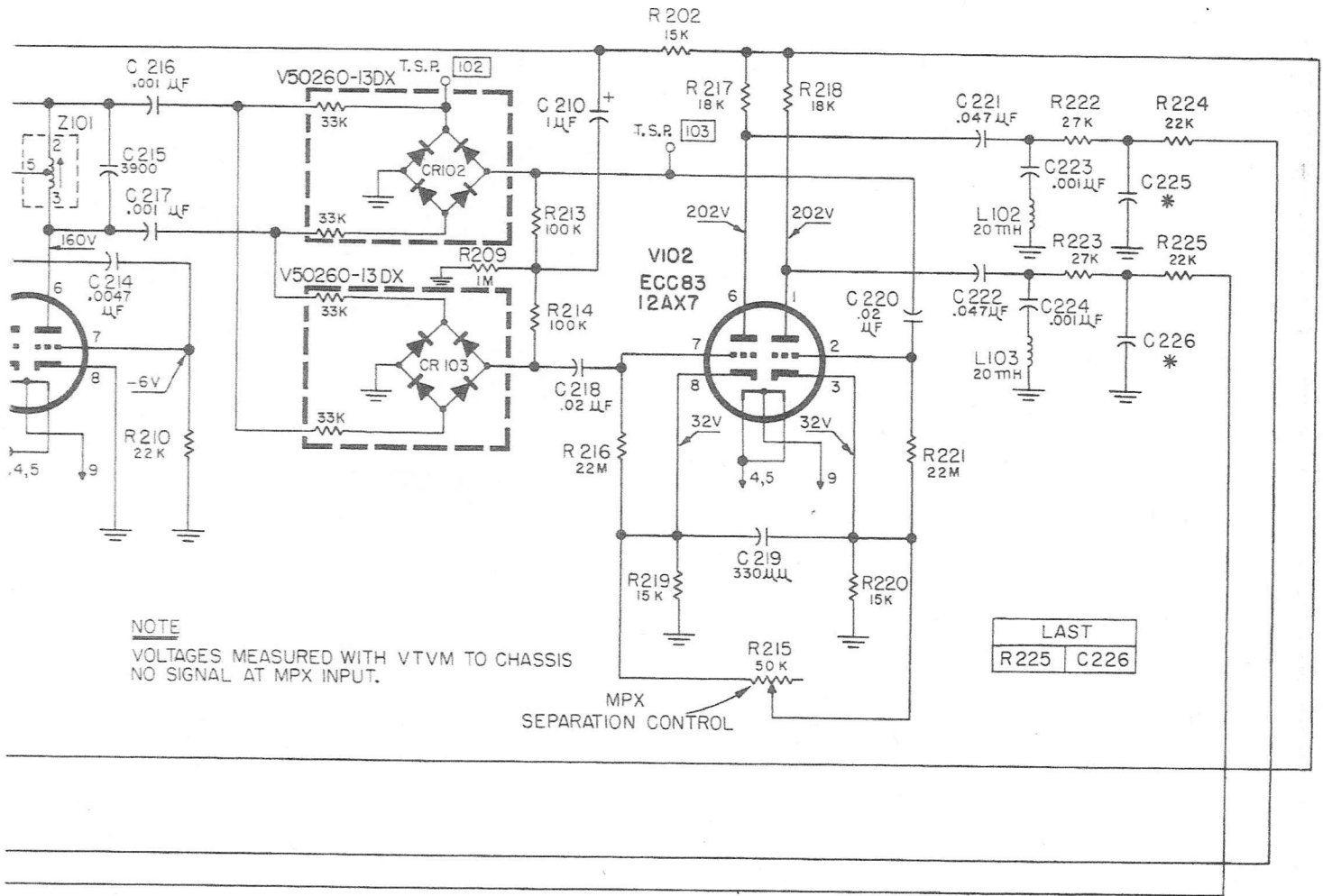

**NOTE**  
 VOLTAGES MEASURED WITH VTVM TO CHASSIS  
 NO SIGNAL AT MPX INPUT.

LAST	
R225	C226

AW# 2078C P1007-1 SCHEMATIC  
 MPX 65

## MULTIPLEX DECODER

250089-1		
250073-2	R201	Composition, 4.7K, 1/2 W
0197-104	R202	Composition, 15K, 1/2 W
250332-6	R203	Composition, 10M, 10%, 1/2 W
250089-2	R204	Dep. Carbon, 1M
250089-5	R205	Dep. Carbon, 220K, 1/2 W
250183-5	R206	-Deleted-
250089-5	R207, 208	
0197-103	209	Dep. Carbon, 1M
250072-3	R210	Dep. Carbon, 22K
250072-5	R211, 212	-Deleted-
50072-10	R213, 214	Dep. Carbon, 100K
800 only	R215	Potentiometer, 50K, MPX Separation
Use noted.	R216	Composition, 22M, 10%, 1/2 W
	R217, 218	Dep. Carbon, 18K, 1/2 W
	R219, 220	Dep. Carbon, 15K, 1/2 W
	R221	Composition, 22M, 10%, 1/2 W
<b>Part No.</b>		
20BF226K		

RC20BF472J
RC20BF153J
RC20BF106K
R12DC105J
R33DC224J
---
R12DC105J
R12DC223J
---
R12DC104J
R50150-4
RC20BF226K
R33DC183J
R33DC153J
RC20BF226K

R222, 223	Dep. Carbon, 27K
R224, 225	Dep. Carbon, 22K

R12DC273J
R12DC223J

### MISCELLANEOUS

Symbol	Description	Part No.
CR100	Diode, Type 1112	V1112
CR102, 103	Diode Bridge	V50260-13DX
L100	Coil, low pass	L50210-30
L101	Coil, 5.25MH	L50334-1
L102, 103	Coil, 20MH	L50334-2
Z100	Transformer, 19Kc	ZZ50210-34
Z101	Coil, 38Kc	ZZ50210-33

# ALIGNMENT INSTRUCTIONS • MULTIPLEX SECTION

STEPS	GENERATOR			INDICATOR	ALIGNMENT		
	CONNECTION	AUDIO FREQUENCY	RF MODULATION	TYPE & CONNECTION	ADJUST	INDICATION	NOTES
1	Audio oscillator connected to lug 1	80 KC—1 volt	None	AC VTVM to junction of C210 and R209	L100 (Use hex alignment tool)	Minimum voltage	
2	Multiplex generator audio output to lug 1 (See Note 1)	19 KC ( $\pm 5$ cps) pilot tone, 100 mv	None	DC VTVM to T.S.P. 101	Z100 top and bottom (Use hex alignment tool)	Maximum voltage	1
3	Same as Step 2	19 KC pilot tone, 50 mv	None	Scope horiz. input to 19 KC output of gen.; vert. input to junction of C216 and R209. External sweep	Z101 (Use K-tran alignment tool)	Stable 2:1 Lissajous pattern. Disregard phase of pattern	1
4	Same as Step 2	19 KC	None	Same as Step 3	Vary generator 19 KC output from 50 to 200 mv	Lissajous pattern should remain stationary over the entire 150 mv range	1, 2
5	Same as Step 2	1000 cps on left (A) channel only, 1 volt rms (2.8 P-P)	None	AC VTVM and scope vert. input to channel A output lug. Internal sweep. DC VTVM to T.S.P. 101	Z100 top (Use hex tool)	Maximum indication on AC VTVM. Clean 1000 cps waveform on scope	1, 3
6	Same as Step 2	1000 cps on right (B) channel only, 1 volt rms (2.8 P-P)	None	Same as Step 5	MPX separation R215	Minimum reading on AC VTVM should be at least 33 db below reading obtained in Step 5	1
7	Same as Step 2	Same as Step 6	None	Move scope input and AC VTVM to channel B output lug	-----	Note and record voltage reading on AC VTVM	1
8	Same as Step 2	1000 cps on left (A) channel only, 1 volt rms (2.8 P-P)	None	Same as Step 7	-----	AC VTVM reading should be at least 33 db below reading observed in Step 7	1
9	Same as Step 2	8000 cps on right (B) channel only, 1 volt rms (2.8 P-P)	None	Same as Step 7	-----	AC VTVM reading should be the same as observed in Step 7	1
10	Same as Step 2	8000 cps on left (A) channel only, 1 volt rms (2.8 P-P)	None	Same as Step 7	-----	AC VTVM reading should be at least 18 db below reading observed in Step 9	1
11	Repeat Steps 9 and 10 with scope and AC VTVM connected to channel A output lug, but start with 8000 cps applied to left channel for first reading, then switch to right channel for second reading.						
12	Multiplex generator RF output to 300-ohm antenna terminals	1000 cps on left (A) channel only	100% (75 KC Dev.) No pre-emphasis	Move scope input and AC VTVM to channel A output lug	-----	Note and record voltage reading on AC VTVM	4
13	Same as Step 12	1000 cps on right (B) channel only	Same as Step 12	Same as Step 12	R215	Minimum reading on AC VTVM should be at least 33 db below reading observed in Step 12	4
14	Same as Step 12	8000 cps on left (A) channel only	Same as Step 12	Same as Step 12	-----	AC VTVM reading should be 10 db below reading observed in Step 12	4
15	Same as Step 12	8000 cps on right (B) channel only	Same as Step 12	Same as Step 12	-----	AC VTVM reading should be 28 db below reading observed in Step 12	4

**NOTE:** The above procedure is based on the use of the FISHER Model 300 Multiplex Generator.

1 — In steps 2 through 11, the audio output of the Multiplex Generator should be connected to lug 1 of the multiplex sub-chassis through a 12,000 ohm, ½-watt, carbon resistor, and a 180 uuf capacitor should be connected between lug 1 and ground. The wiring from the MPX TEST jack on the main chassis to lug 1 must be disconnected during Steps 2 through 11.

2 — The vertical amplitude of the Lissajous pattern will increase slightly

as the generator output is increased. This is a normal occurrence.

3 — If DC VTVM reading falls below -9 volts when maximum reading is obtained on the AC VTVM, readjust bottom of Z100, then repeat Step 5. Repeat this procedure until maximum AC VTVM reading is obtained with DC VTVM reading greater than -9 volts.

4 — Tune the FISHER to the RF output frequency of the Multiplex Generator.

# TUBE LAYOUT

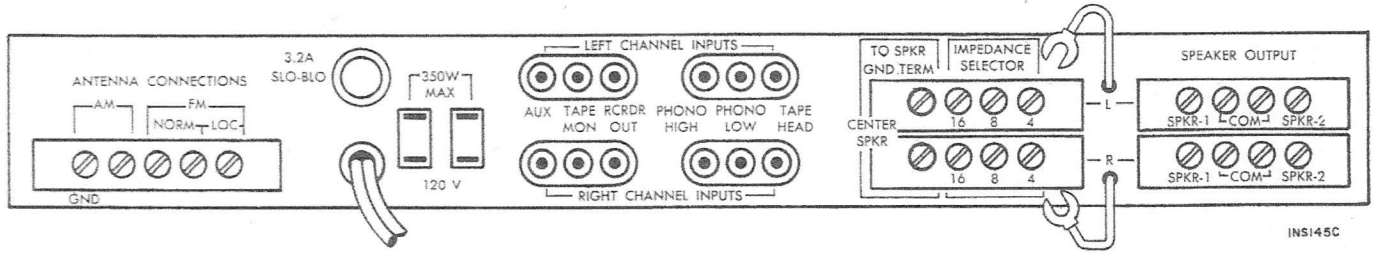
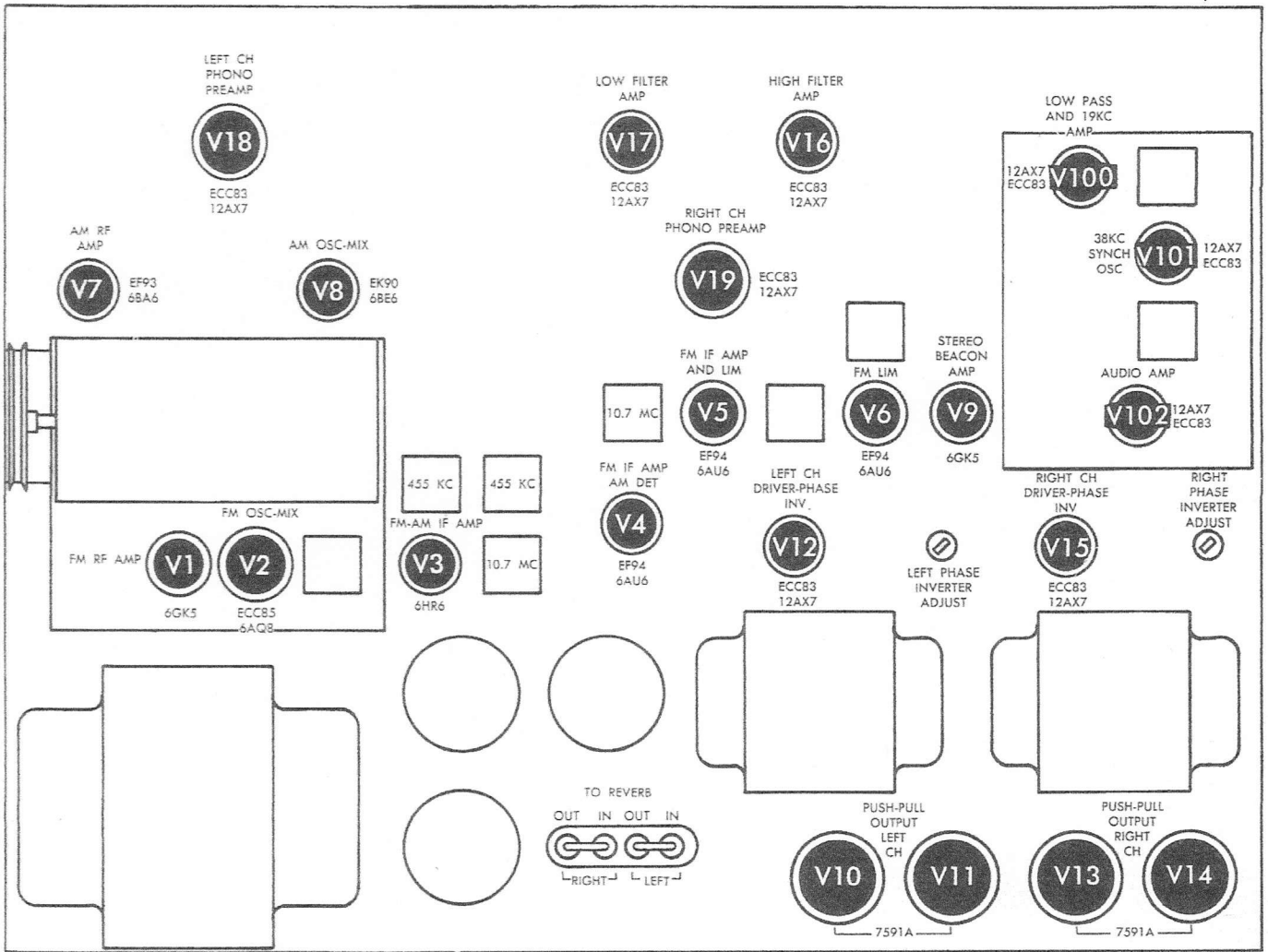

## POWER TRANSFORMER STRAPPING

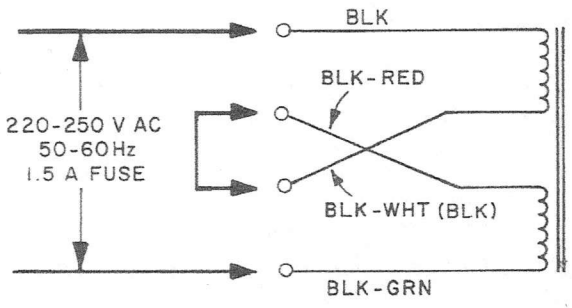
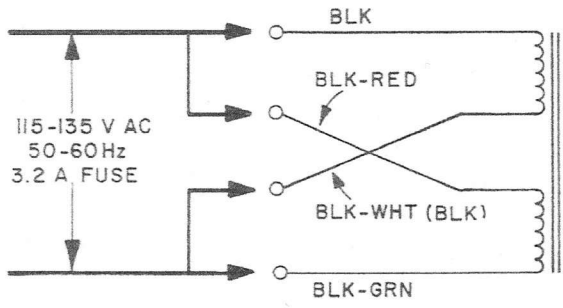

# SERVICE NOTES

## Receiver Phase Inverter Adjustment

The following procedure is used to balance the phase inverter for minimum IM distortion. Two 4-ohm, 30-watt resistors and an IM distortion analyzer are required for this adjustment.

- 1 — Connect one of the two 4-ohm loads to the appropriate terminals of each channel.
- 2 — Turn the equipment on, allowing a few minutes for warmup.
- 3 — Connect the output of the IM distortion analyzer to the left channel AUX input. (First, remove the connector from the tape recorder, if present.)
- 4 — Connect the input of the IM distortion analyzer across the 4-ohm load connected to the left channel.

5 — Set the receiver volume control to produce a 25-watt RMS output, as measured across the left channel load.

6 — Set the left channel phase inverter adjustment control for minimum IM distortion.

7 — Connect the output of the IM distortion analyzer to the right channel AUX input, and the analyzer input across the right channel load.

8 — Set the Volume control to produce a 25-watt RMS output, as measured across the right channel load.

9 — Set the right channel phase inverter adjustment control for minimum IM distortion.

## DIAL STRINGING PROCEDURE

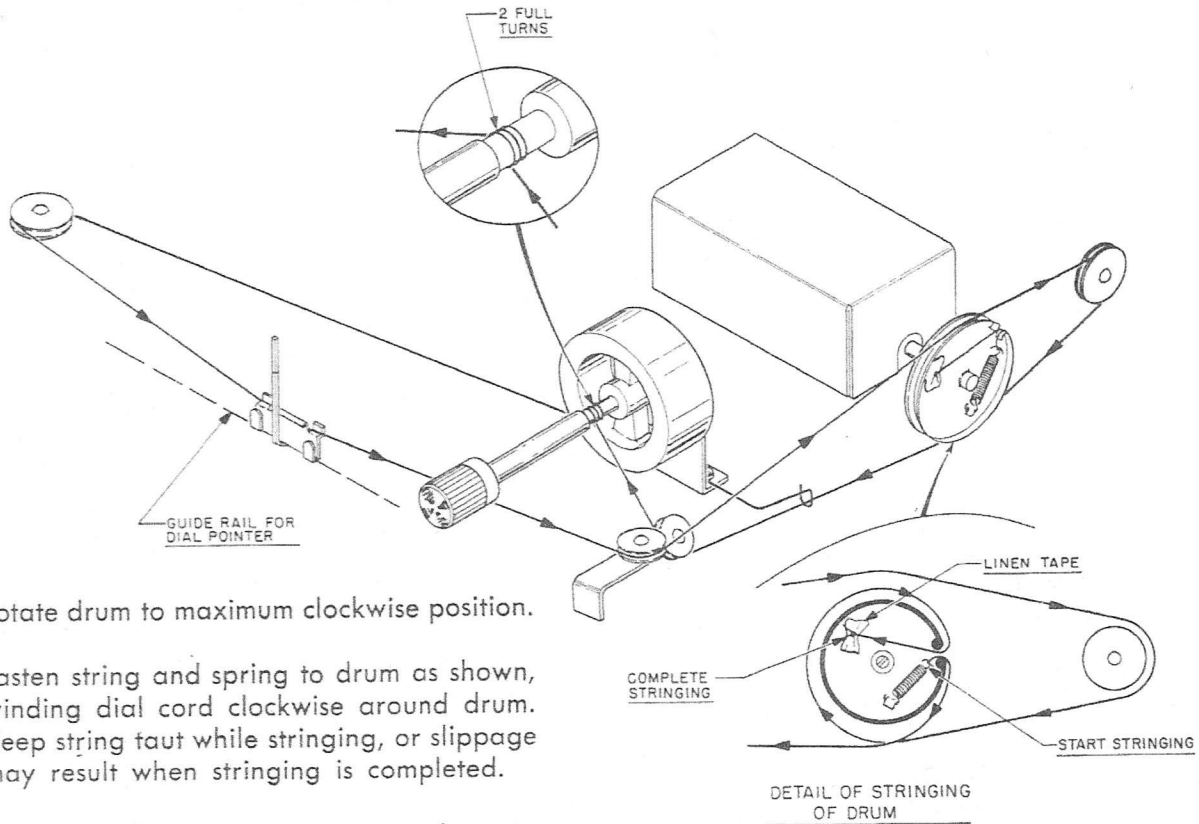

- 1—Rotate drum to maximum clockwise position.
- 2—Fasten string and spring to drum as shown, winding dial cord clockwise around drum. Keep string taut while stringing, or slippage may result when stringing is completed.
- 3—After completing stringing, set pointer to zero (0) on the dial logging scale, and glue pointer to dial cord.

INS230



FISHER RADIO CORPORATION • NEW YORK