

EMOTIVA

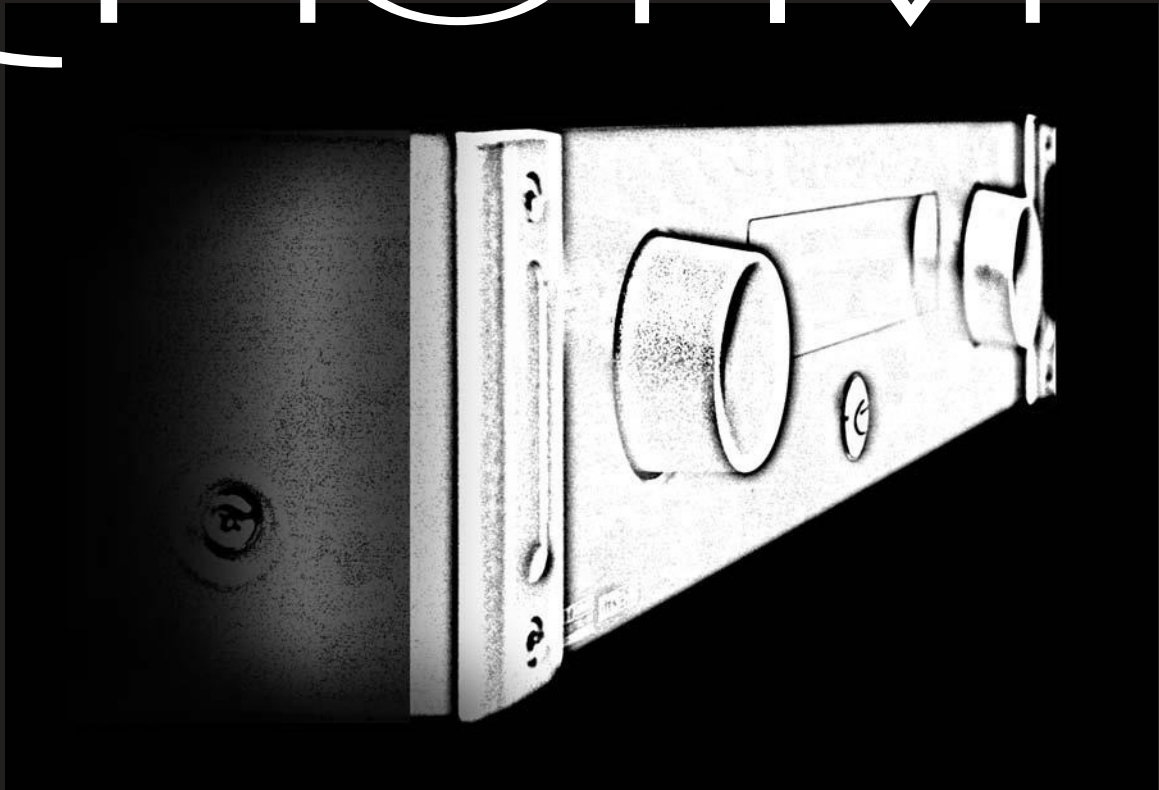

WHERE PASSION
AND HOME THEATRE MERGE

LMC-1

PROFESSIONAL 7.1 AV PREAMPLIFIER/PROCESSOR

Table of Contents

Safety Precautions	7
NEC (National Electrical Code) Standards	9
A Note for the Cable Television (CATV) Installer	9
Antenna Grounding Outside the House	9
Thank You for your LMC-1 Purchase	10
Unpacking the LMC-1	11
Inventory	11
Recording the Serial Number	11
Emotiva LMC-1 Preamplifier	12
Professional Preamplifier/Processor Features	12
Front Panel Layout	13
Rear Panel Layout	14
LMC-1 Remote	15
Connection Diagrams	16
Connecting a DVD-V Player and TV	16
Connection using Component Video and Digital Audio	16
Connection using S-Video and Analog Audio	16
Connecting a CD Player	17
Connection using Digital Audio	17
Connection using Analog Audio	17
Connecting the 7.1 Channel Inputs	18
Connecting a Cable Box or DSS Receiver	19
Connection of the Cable Box or DSS Receiver	19
Connection of a HDD, DVR, or TiVo Type Device	19
Connecting a Tape Player or VCR	20
Connection of the Tape Player	20
Connection of the VCR	20
Connecting Auxiliary Sources	21
Connection of the AUX 1 Input	21
Connection of the AUX 2 Input	21
Connecting Antennas and External Amplifiers	22
Connection of the AM and FM Antennas	22
Connection of the 7.1 Channel Preamp Outputs	22
Zone 2 Connections	23
Connection of the Internal Zone 2 Amplifier	23
Connection of the Zone 2 Preamp Outputs	23

RRC-1 Wall Plate	24
Description of the RRC-1 Wall Plate Accessory	24
Installing and Connecting the RRC-1 Wall Plate Accessory	24
Quick Setup of the LMC-1	25
A Note About “Learning” Remotes	25
LMC-1 Programming and Calibration	27
Navigation on the Front Panel	27
Navigating the OSD with the Remote	27
Input Select Menu	28
Audio Inputs	28
Video Inputs	28
Mode Select Menu	29
Bypass Mode	29
Dolby Modes	29
DTS Modes	30
DSP Modes	30
Sound Adjust Menu	31
Bass and Treble Adjustment	31
Balance Left and Right Adjustment	31
Center and Surround Speaker Level Adjustments	31
Subwoofer Level Adjustment	31
Distance/Delay Settings	32
Zone Control Menu	32
Function Menu	33
Noise Test	33
Screen Display	34
Speaker Configuration	35
DRC	37
Blue Screen	37
Factory Default	38
Using the AM/FM Tuner	39
Tuning Stations	39
Manually Tuning (UP/DOWN)	39
Direct Numeric Tuning	40
Automatic Tuning	40
Selecting FM Stereo/Mono Modes	40
Storing AM or FM Presets	41
Store a Preset from the Front Panel	41
Store a Preset from the Remote	41
Deleting Preset Channels	41

Using Zone 2	42
Optional Zone Control Keypad	42
RRC-1 Installation	42
Operating Zone 2	42
Zone 2 Operation from the LMC-1 Front Panel	42
Zone 2 Operation from the LMC-1 Main Remote	43
Zone 2 Operation from the RRC-1 Wall Plate	43
Zone 2 Operation from the LMC-1 Zone 2 Remote	44
Zone 2 Preamp Outputs with External Amplification	44
Using the +12 VDC Control Output to Turn On Other Devices	44
Speaker Placement Tips	45
Tips Before Beginning	45
The Front Speakers	46
The Center Speaker	46
The Surround Speakers	47
Surround Back Speakers	47
Subwoofer Location	48
Troubleshooting Guide	50
No Sound (from one or more full range speakers)	50
No Subwoofer (or poor output)	50
Poor AM Reception	50
Poor FM Reception	50
Input Selection Problems	51
There is No TV Picture	51
No Tone Control Functions	51
No Dolby Digital or DTS Playback	51
No On Screen Display	52
Blue Screen and No Picture During On Screen Display	52
Sound drops out with CD or DVD playback	52
Remote Not Working	52
ZONE 2 Not Working	52
External Amplifier(s) Shut Down (Often or Prematurely)	53
External Amplifier(s) Do Not Turn Off with LMC-1	53
Check the following:	53
LMC-1 "Locks Up" (No Response)	53
Reset Procedure	53
"Hum" Noises	53
Other Probable Causes of Noise	54
Problems with the whole A/V System	54

LMC-1 Technical Specifications	55
Licensing and Trademark Disclosures	56
DTS Disclosure	56
Dolby Disclosure	56
Apple Disclosure	56
Sirius Satellite Radio Disclosure	56
XM Satellite Radio Disclosure	56
Emotiva Disclosure	56
Limited Warranty	57
Service Assistance for the LMC-1	57

Safety Precautions

Read this User's Guide thoroughly before attempting to install and configure the Emotiva LMC-1 Preamplifier. All the safety and operation instructions should be read before any operation of the component(s) begin. After successful installation and configuration of the Emotiva LMC-1 Preamplifier, be sure to retain this manual in a safe place for any future reference needs.



All warnings on the Emotiva LMC-1 Preamplifier and in these operating instructions should be followed. Safety is a key component to a long lasting and trouble free installation. The vast majority of the subsequent safety precautions involve simple common sense. If you are not comfortable with the installation of audio/video entertainment equipment, it will be to your benefit to seek the services of a qualified installation professional.

NEVER use the LMC-1 Preamplifier near water such as a bathtub, washbowl, kitchen sink, laundry tub, in a wet basement, or near a swimming pool, etc. There is a risk of electric shock to your body and permanent damage to the equipment. Electric shock may result in permanent bodily injury or death.

The Emotiva LMC-1 Preamplifier should be situated so that its location or installation position does not interfere with proper ventilation. The Emotiva LMC-1 Preamplifier should not be situated on a bed, sofa, rug, or similar surface that may block any ventilation openings; or placed in a built-in installation such as a bookcase, cabinet, or closed equipment rack that may impede the flow of air through ventilation openings. If installed in a closed equipment rack for custom installations, be sure to add forced air ventilation so that it has adequate air circulation. The Emotiva LMC-1 Preamplifier should be situated away from heat sources such as radiators, or any other devices which produce heat.

The Emotiva LMC-1 Preamplifier should be connected to a power supply only of the type described in this User's Guide and what is labeled on the LMC-1 component. Power supply cords should be routed so that they are not in high foot traffic areas or pinched by items placed upon or against them, paying particular attention to cords at the wall plugs, convenience receptacles, and the point where they connect into the LMC-1 Preamplifier. The power cord of the LMC-1 Preamplifier should be unplugged from the outlet when unused for a long period of time. When it's time for cleaning the Emotiva LMC-1 Preamplifier, it should be cleaned only as recommended in this User's Guide. Never spray liquids directly into the component's vent openings. Care should be taken so that small objects do not fall into the inside of the LMC-1 Preamplifier.

The following situations require your Emotiva LMC-1 Preamplifier is serviced only by qualified service personnel:



1. *The power-supply cord or the plug has been damaged; or*
2. *Objects have fallen, or liquid has spilled into the component; or*
3. *The LMC-1 has been exposed to rain; or*
4. *The LMC-1 does not appear to operate normally or exhibits a marked change in performance; or*
5. *The LMC-1 has been dropped, or its enclosure or chassis is damaged.*

The user should not attempt to service the LMC-1 Preamplifier beyond the means described in this Owner's Guide. All other servicing should be referred to qualified service personnel.



To prevent electric shock, do not use this polarized plug with an extension cord, receptacle or other outlet unless the blades can be fully inserted to prevent blade exposure.

Pour preevenir les chocs electriques ne pas utiliser cette fiche polarises avec un prolongateur, un prise de courant ou une autre sortie de courant, sauf si les lames peuvent titre inserees a fond sans laisser aucune parllle a decouvert.

Grounding or Polarization — Precautions should be taken so that the grounding or polarization means of the component is not defeated.

This apparatus does not exceed the Class A/Class B (whichever is applicable) limits for radio noise emissions from digital apparatus as set out in the radio interference regulations of the Canadian Department of Communications.

ATTENTION — Le present appareil numerique n'emmet pas de bruits radioelectriques depassant las limites applicables aux appareils numeriques de class A/de class B (selon le cas) prescrites dans le reglement sur le brouillage radioelectrique edicts par les ministere des communications du Canada.

For questions regarding service, please contact:

EMOTIVA

Toll Free - (877) EMO-TECH
Website - www.emotivaaudio.com

If you purchased your unit through AV123 and have service questions, please contact:

AV123
2150 W. 6th Ave, Suite L
Broomfield, CO 80020

Toll Free - (877) 543-7500
Website - www.av123.com
e-mail - info@av123.com

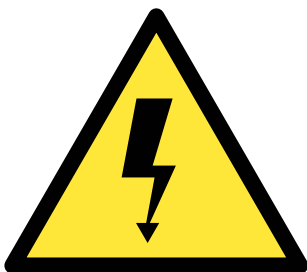

WARNING – TO REDUCE THE RISK OF FIRE OR ELECTRIC SHOCK, DO NOT EXPOSE THIS APPLIANCE TO RAIN OR MOISTURE.

CAUTION: TO PREVENT ELECTRIC SHOCK, MATCH WIDE BLADE OF PLUG TO WIDE SLOT, FULLY INSERT.

ATTENTION: POUR EVITER LES CHOCS ELECTRIQUES, INTRODUIRE LA LAME LA PLUS LARGE DE LA FICHE DANS LA BORNE CORRESPONDANTE DE LA PRISE ET POUSSER JUSQU'AU FOND.

NEC (National Electrical Code) Standards

A Note for the Cable Television (CATV) Installer

This reminder is to call the CATV system installer's attention to Article 820-40 of the NEC that provides guidelines for proper grounding and in particular, specifies that the cable ground shall be connected to the grounding system of the building as close to the point of cable entry as practical.

Antenna Grounding Outside the House

If an outside antenna is connected to the receiver, be sure the antenna system is grounded so as to provide some protection against voltage surges and built-up static charges. Article 810 of the National Electrical Code, ANSI/NFPA 70, provides information with regard to proper grounding of the lead-in wire to an antenna-discharge unit, connection to grounding electrodes, and requirements for the grounding electrode. See diagram below.

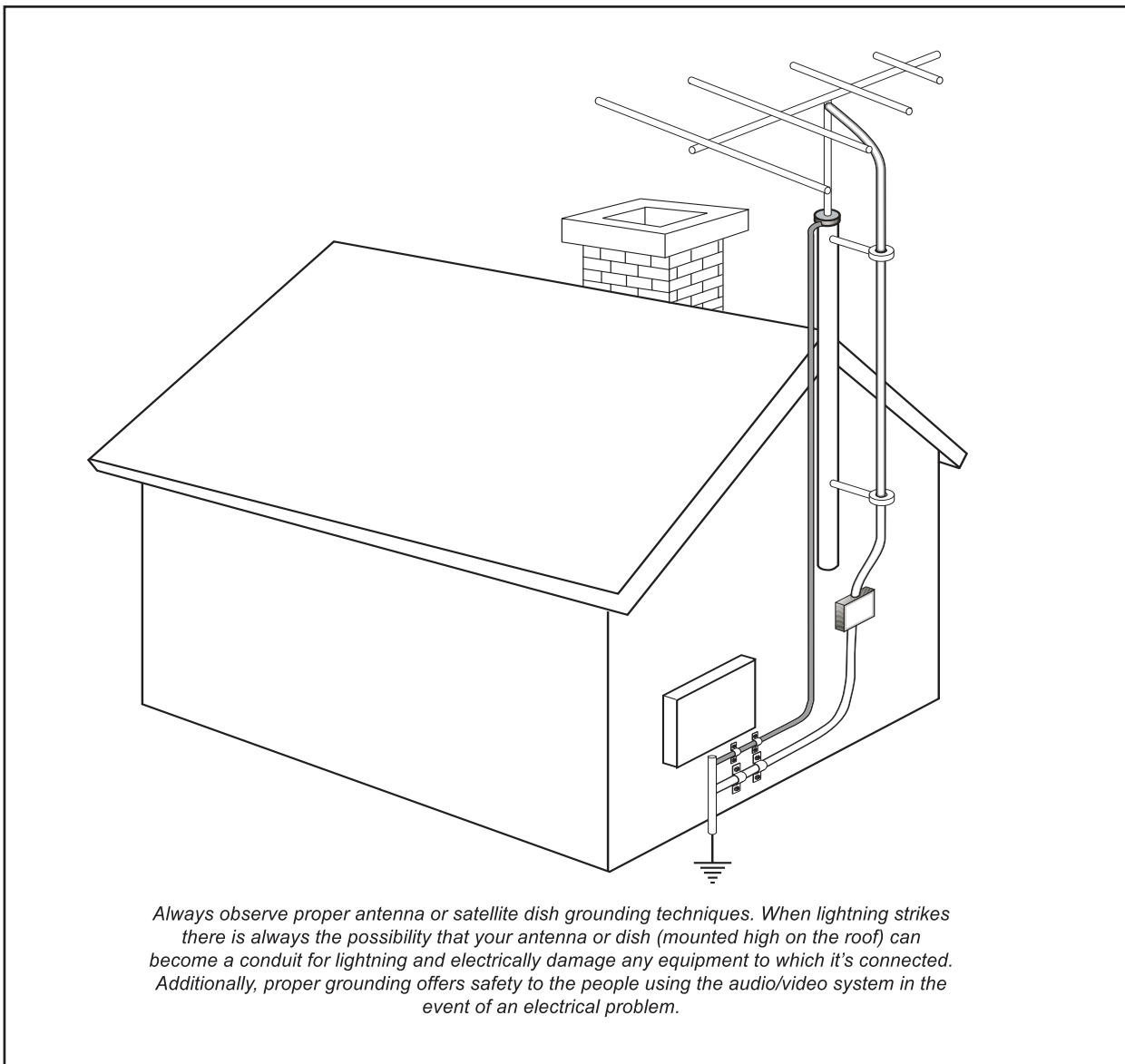

Thank You for your LMC-1 Purchase

Dear Home Entertainment Enthusiast,

Thank you for purchasing the Emotiva LMC-1 Preamplifier. We sincerely believe that it offers you outstanding performance and value. Emotiva products are engineered and produced with the highest quality materials and incorporate the latest technology. We think you will find the Emotiva LMC-1 meets or exceeds your expectations.

The Emotiva LMC-1 is unlike any home entertainment product on the market. It has been designed with the user in mind. By employing technology that makes sense, the Emotiva LMC-1 does most of the thinking for you. This allows you to spend more time enjoying various audio and video sources without requiring an engineering degree to operate the component. What's more, the Emotiva LMC-1 does it all with exceptionally refined cosmetics and a sound quality that will satisfy even the most discriminating tastes.

The Emotiva LMC-1 features an array of leading edge technologies and all the features necessary to perform the functions expected of a high end home preamplifier/processor. At Emotiva, we remember that creating home audio/video products means that they should be easy to use while delivering unparalleled performance.



Unpacking the LMC-1

The Emotiva LMC-1 Preamplifier should reach you in flawless condition. If you notice any shipping damage or other issues upon unpacking the unit, please contact your Emotiva Retailer immediately.

Inventory

Contained in the box should be the LMC-1 unit, the remote control, (2) AAA batteries, both AM and FM antennas, a 3.5mm amplifier turn on cable, and a IEC standard 3 prong power cord.

Gently lift out the unit and remove all the packing material and accessories. It is important to save all the packing materials and the box in case your Emotiva LMC-1 ever needs to be moved or shipped back to the factory for service.

Make sure that you keep your sales receipt. It is the only way for Emotiva to establish the duration of your Limited Warranty and it may come in useful for insurance purposes.

Please take a moment to fill out and mail the Emotiva Customer Response card.

Recording the Serial Number

Please read the serial number located on the rear panel and record it below. Also record the place where you purchased this product and the date of purchase.

Model Number _____ LMC-1 _____

Serial Number _____

Place of Purchase _____

Date of Purchase _____

Emotiva LMC-1 Preamplifier

Professional Preamplifier/Processor Features

- *24-bit/192kHz Audiophile Grade Digital Processing*
- *32-bit, 20 MHz Crystal Semiconductor microprocessor*
- *On Screen Display (OSD)*
- *AM/FM tuner with 40 presets*
- *Digital Domain Treble and Bass tone controls*
- *Dolby Digital, Dolby Digital EX[®], and Dolby Pro Logic IIx[®] decoding modes*
- *DTS, DTS ES[®], and DTS NEO:6[®] decoding modes*
- *DSP “simulated” surround mode for enhancement of two channel sources*
- *Supports all digital sampling rates to 192 kHz*
- *0.5 dB resolution on volume control and all channel level adjustments*
- *Gold plated input and output connectors*
- *Four coaxial digital inputs*
- *Three optical digital inputs*
- *Seven analog audio (RCA) inputs*
- *Additional 8 channel “7.1” analog input with separate RCA connectors for DVD-A/SACD format*
- *Three component video inputs and one component video output*
- *7.1 Channel Input tracks to the AUX1 video input for Universal DVD use (DVD-V connects as AUX1)*
- *Automatic video format transcoder up converts Composite and S-Video source to 480i Component*
- *7.1 channel outputs (L, C, R, LS, RS, LBS, RBS, and SUB)*
- *Multiple Frequency Bass Management Feature for all Full Range Channels (60-150Hz Selectable)*
- *Built in 50 watt x 2 Zone 2 power amplifier*
- *Zone 2 can play sources independent of the Main Zone*
- *Optional RRC-1 Wall Plate for control from another room as Zone 2 (Sold as an accessory)*
- *Optional HSM-1 HDMI 2x1 External Switching Module (Sold as an accessory)*
- *Trigger output for external amplifiers (3.5mm cable for Emotiva LPA-1 amplifier is included)*
- *Steel chassis with milled aluminum faceplate trim and cobalt blue illumination*
- *IEC standard, Class 1, 3 prong removable power cord*

Front Panel Layout

Vacuum Fluorescent Display

The cool blue VFD display shows the source input (or AM/FM station) as a default, but has full display capabilities for all other selections including programming menu functions.

I/R Remote Receiver

This small receiver to the right of the VFD is how the LMC-1 receives commands from the supplied remote control. Be sure not to block the receiver during normal operation. Direct sunlight on this area may reduce the range of the remote.

Main Volume Knob

This knob provides the main volume for the system.

If the unit is in the MENU mode, turning the volume knob up or down AUTOMATICALLY exits the MENU mode.

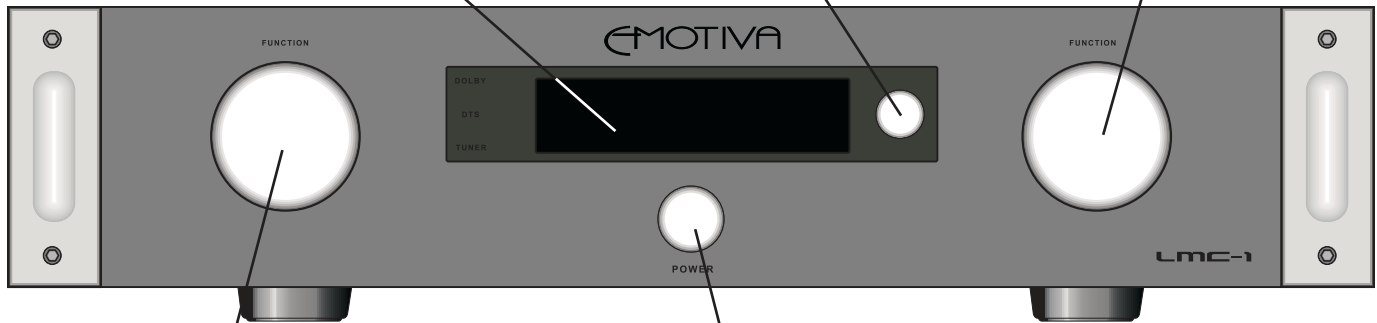

Function Knob

This is a simple, yet multi-functional control that offers complete programming and control of the LMC-1 (with the exception of volume). The Function Knob has 3 separate functions:

- Push IN
- Scroll UP
- Scroll DOWN

The majority of functions are selected by first pushing in to navigate the correct sub-menu selection and then using the SELECT UP and DOWN functions to choose between the available selections. While the unit's display shows the menu steps, the On Screen Display (OSD) shows a greater amount of information and makes programming and control from the front panel of the LMC-1 much easier. Tuning AM and FM stations is also accomplished with this knob. For a complete programming overview, please see pages 27-41 of this guide.

Soft Touch Power Switch

This switch provides the ON/OFF control of the LMC-1 from the front panel. When the unit is off and in standby mode, the switch illuminates yellow. Once the unit is turned on, the switch illuminates blue. The unit can also be turned ON and OFF with the supplied remote control.

Zone 2 power must be turned on from the LMC-1 menu or from the second zone accessory items. Please see pages 42-44 for additional Zone 2 details.

Please note that upon initial power up of the LMC-1, the initialization process can take up to 10 seconds. The initialization process must complete before the power switch will respond.

Rear Panel Layout

Zone 2 Powered Output

This 50 watt x 2 output offers an onboard source for powering the LMC-1 second zone. The speakers in the second room would connect to these terminals (or to a rotary type volume control if no RRC-1 wall plate is used)

Analog Source Inputs

This group of analog RCA inputs is intended for any "analog only" sources such as VCR or Tape, as well as for situations where the user chooses the analog output from a DVD, CD or digitally capable CABLE or AUX source component.

Power Receptacle and Switch

There is an IEC standard Class 1, 3 prong power receptacle (cord is also included with LMC-1) and a master power switch to enable on/off command with the remote or via the front panel switch.

7.1 Channel Analog Input

This group of analog RCA inputs is intended for a dedicated DVD-A or SACD player where the decoding process is handled inside the player and the output is multi-channel analog. This input has no internal bass management in the LMC-1

Digital Source Inputs

This group of digital inputs is separated into 3 optical inputs (DVD, CABLE/CD, and AUX1) and 4 coaxial inputs (DVD, CD, CABLE, and AUX1)

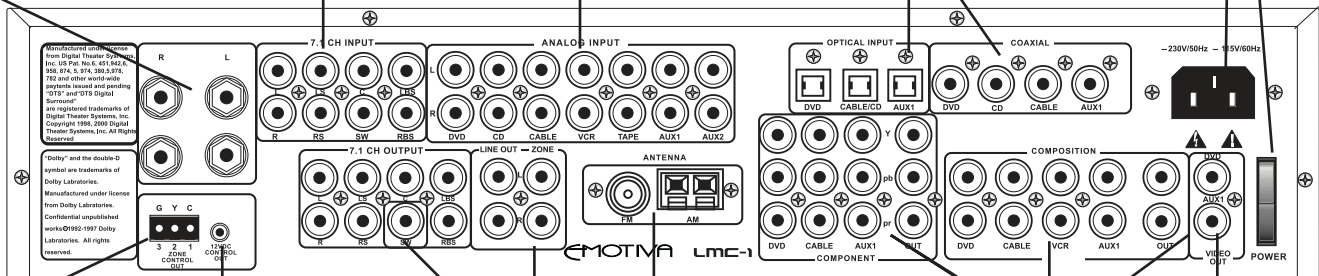

Remote Amplifier Turn-On

This 3.5mm jack connects through the supplied 1 meter cable to an external amplifier for a turn on command. It mates perfectly to the Emotiva LPA-1 companion amplifier.

Remote Keypad Control

This 3 wire connection is for the RRC-1 wall plate accessory that controls Zone 2 from an alternate location. Please see pages 24, 42-44 for more details of this accessory.

7.1 Channel Analog Output

This group of analog RCA outputs connects to external amplifiers. This gives up to 7 independent full range channels and low frequency channel for connection to a powered subwoofer. Depending on the source (any Analog or PCM in 2ch), the SW output will be active only with SMALL front speaker settings due to internal active crossover functionality.

AM and FM Antenna Jacks

These connections are for the included AM and FM antennas. The AM antenna is a loop type antenna with 2 wire ends that go into the "spring loaded" jacks. The FM antenna simply has a "push on" style "F connector" to connect.

VIDEO OUT jacks are for recording to a VCR as long as the input source is S-Video or Composite Video. This output has no OSD.

Video Inputs and Outputs

These jacks allow input of component video signals from DVD, CABLE, and AUX1 sources and S-Video or composite signals from those and other sources. Each style has a video output so use the highest grade your video display can accommodate. The LMC-1 has a video upconversion feature to make Composite or S-Video have DVD quality resolution, however always use the highest quality inputs and outputs available.

Line and Zone Outputs

The "LINE OUT" jacks are for a 2 channel connection to an additional amplifier or for tape recording. These are active on the Main Zone only. The "ZONE" jacks are for use of an amplifier in the second zone (in addition to or instead of the onboard Zone Amplifier. These are active whenever "Zone 2" is selected. Both are full time digital mix down of the multi-channel inputs.

LMC-1 Remote

The LMC-1 remote control is a full featured, dedicated remote control that offers many discrete buttons for DIRECT ACCESS to most of the critical LMC-1 controls. When used in conjunction with the On Screen Display (OSD), there may be little need to ever touch the front panel of the LMC-1 again if you so choose.

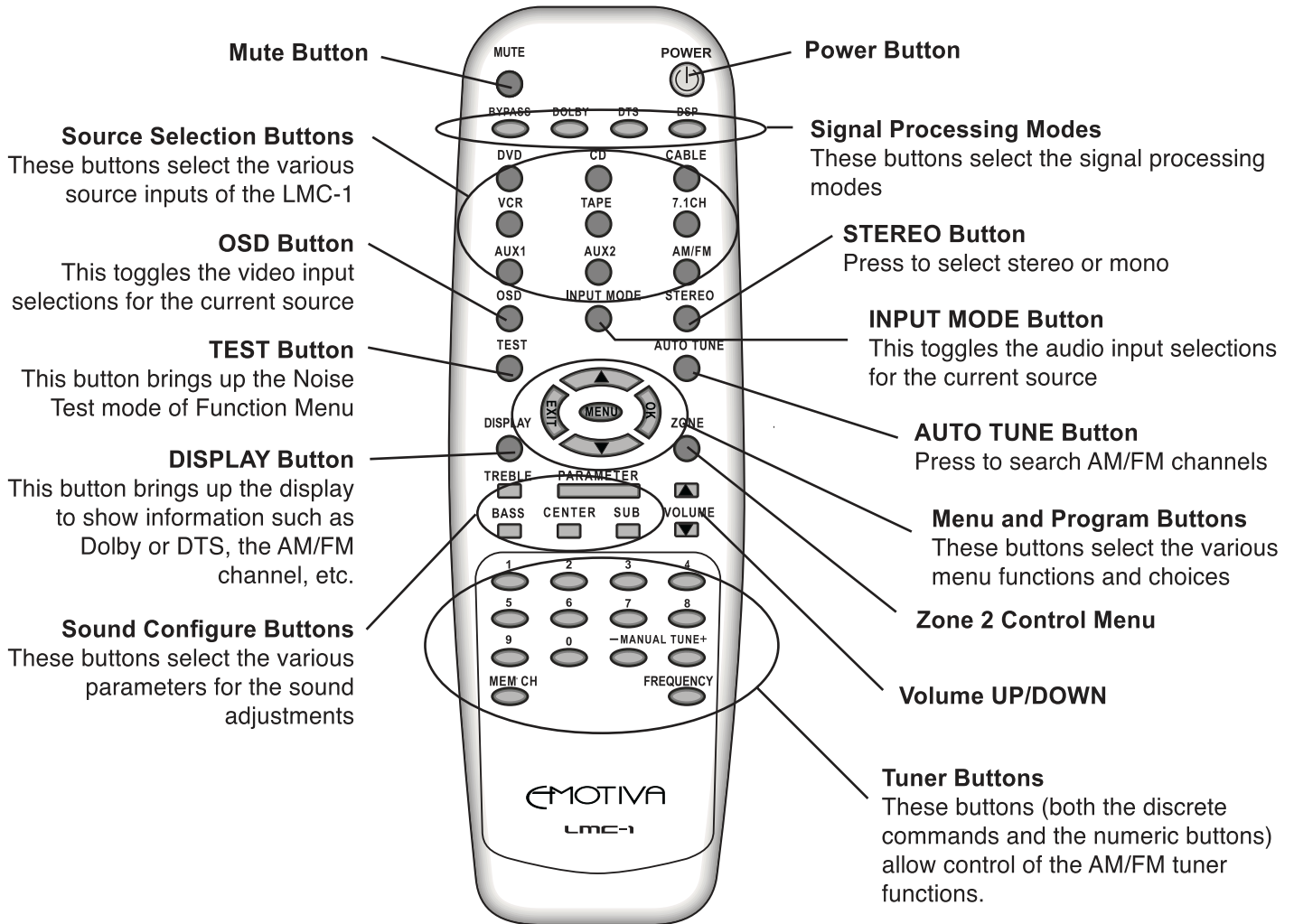

As many home entertainment enthusiasts choose, you may elect to program the LMC-1 remote into a "learning" type remote that is the single (Master) control for all of your home entertainment components. In doing so, you can choose to omit certain setup functions if you wish so you do not inadvertently enter into those functions during normal use with the master remote. A master remote can also provide a unified turn on/off resource for all of the components in the system through the use of a macro program sequence.

Connection Diagrams

Connecting a DVD-V Player and TV

Connection using Component Video and Digital Audio

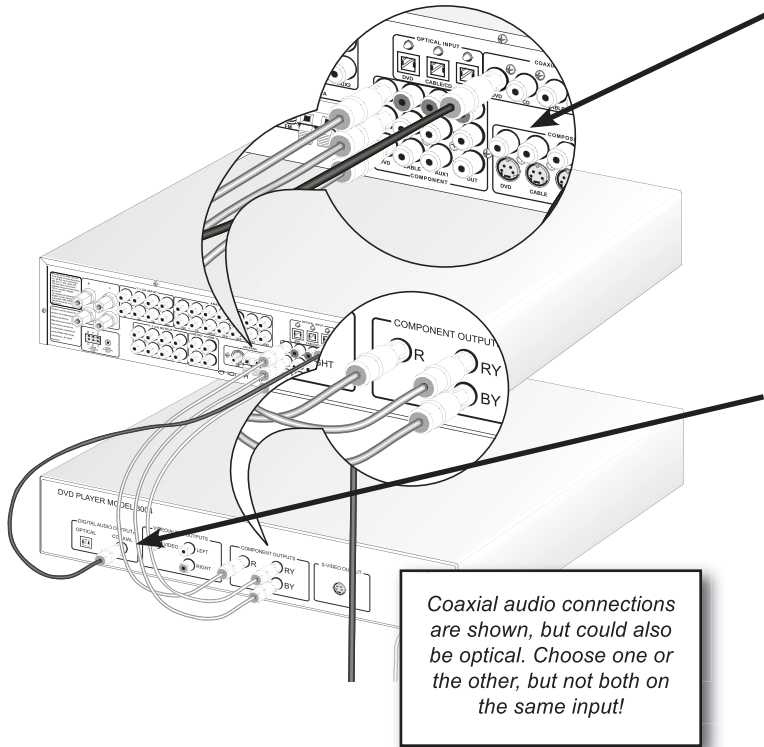

Component Video

This video connection type provides the best visual resolution. Connect the DVD player's Component Video outputs to the inputs on the LMC-1 labeled "DVD" in the COMPONENT section of the rear panel.

Digital Audio

This audio connection type provides the best audio resolution and is necessary for decoding discrete Dolby Digital and DTS source material. Connect the DVD player's coaxial digital or optical digital output to the appropriate input on the LMC-1 labeled "DVD". It does not matter whether you use coaxial or optical connections as far as audio clarity goes, only that the correct input type is assigned in the setup process.

Note: If your DVD-V player is also a DVD-A player and you will use the analog outputs, see the "Connecting the 7.1 Channel Input" diagram for details about sharing the video input while still switching between digital and analog outputs.

Connection using S-Video and Analog Audio

S-Video

This video connection type (as well as Composite Video) provides good visual resolution and can be upscaled with the automatic LMC-1 internal circuitry. Whenever possible, choose Component Video connections for DVD, but if that is not an option this method is a good second choice. Connect the DVD player's S-Video outputs to the inputs on the LMC-1 labeled "DVD" in the S-VIDEO section of the rear panel. If you are using Composite Video connections, connect those in the same way, substituting the S-Video plug for Composite Video on both the DVD player and LMC-1.

Analog Audio

This audio connection type is not as good as the digital audio connection, but will still deliver full bandwidth audio - only in 2 channel instead of 5.1, 6.1, or 7.1. Connect the DVD player's left and right RCA audio outputs to the appropriate RCA inputs on the LMC-1 labeled "DVD". Using RCA inputs will not deliver true Dolby or DTS decoding capabilities.

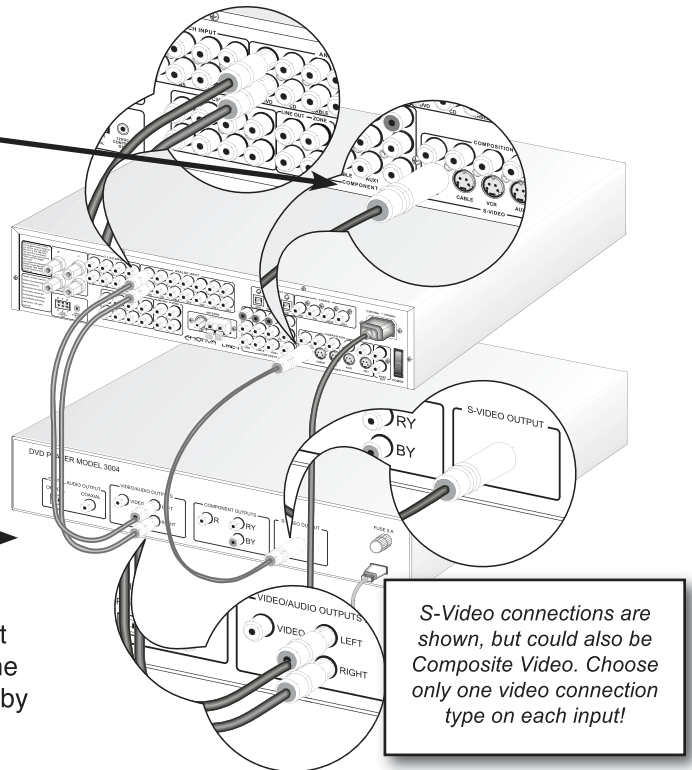

Connecting a CD Player

Connection using Digital Audio

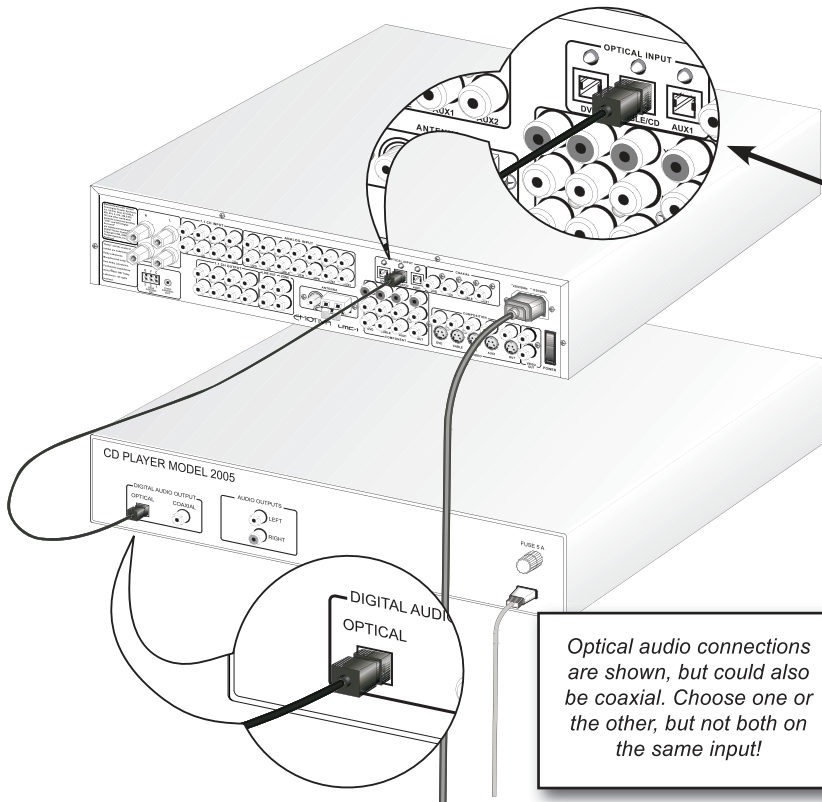

Digital Audio

This audio connection type provides the best audio resolution for CD playback. It also uses the high resolution 24bit D/A converter in the LMC-1 which is better than many D/A converters in consumer grade CD players. Connect the CD player's coaxial digital or optical digital output to the appropriate input on the LMC-1 labeled "CD". It does not matter whether you use coaxial or optical connections as far as audio clarity goes, only that the correct input type is assigned in the setup process. The digital audio input will feed PCM audio data to LMC-1 where it will be converted to the analog domain.

Connection using Analog Audio

Analog Audio

This audio connection type is not as good as the digital audio connection, but will still deliver full bandwidth audio. Connect the CD player's left and right RCA audio outputs to the appropriate RCA inputs on the LMC-1 labeled "CD".

Note: If you are connecting the CD player or CD changer as a dedicated source component for use in Zone 2 (or primarily for Zone 2), analog connection will be just fine since there is only a 2 channel output for Zone 2 and Zone 2 is an "analog only" signal path.

Please note that both DVD and CD digital inputs are not available as Zone 2 sources, so if you have connected the digital input to either CD or DVD and you want those sources available in Zone 2, you MUST ALSO connect the analog RCA audio inputs as shown here. This applies for DVD as well as CD or any other digitally connected source component that you want available in Zone 2.

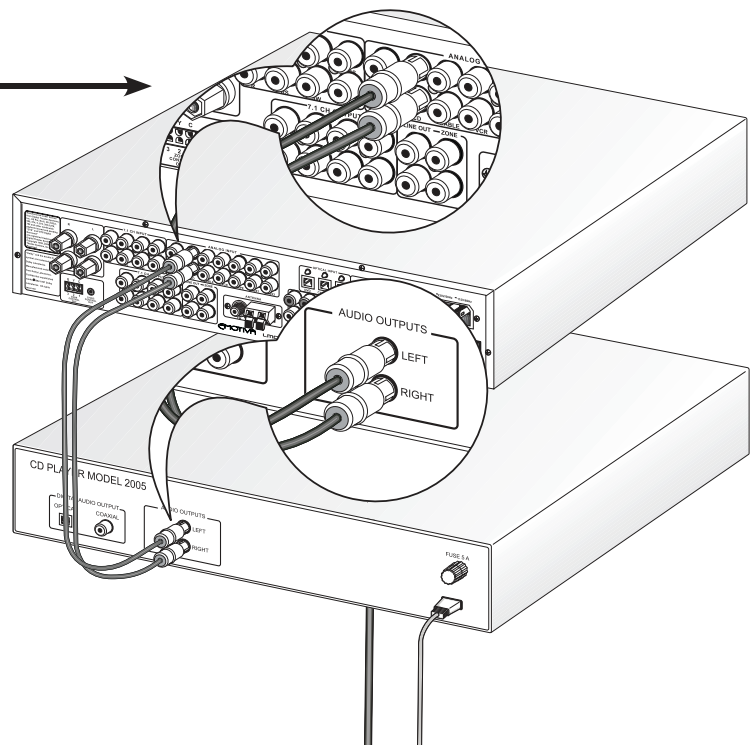

Connecting the 7.1 Channel Inputs

Component Video (AUX 1 Input)

This video connection type provides the best visual resolution. Use this video connection diagram if the DVD-A/SACD player is also the main DVD-Video player for the system. Connect the DVD player's Component Video outputs to the inputs on the LMC-1 labeled "AUX 1" in the COMPONENT section of the rear panel so the video source "tracks" which ever audio input (AUX 1 or EXT 7.1) is used.

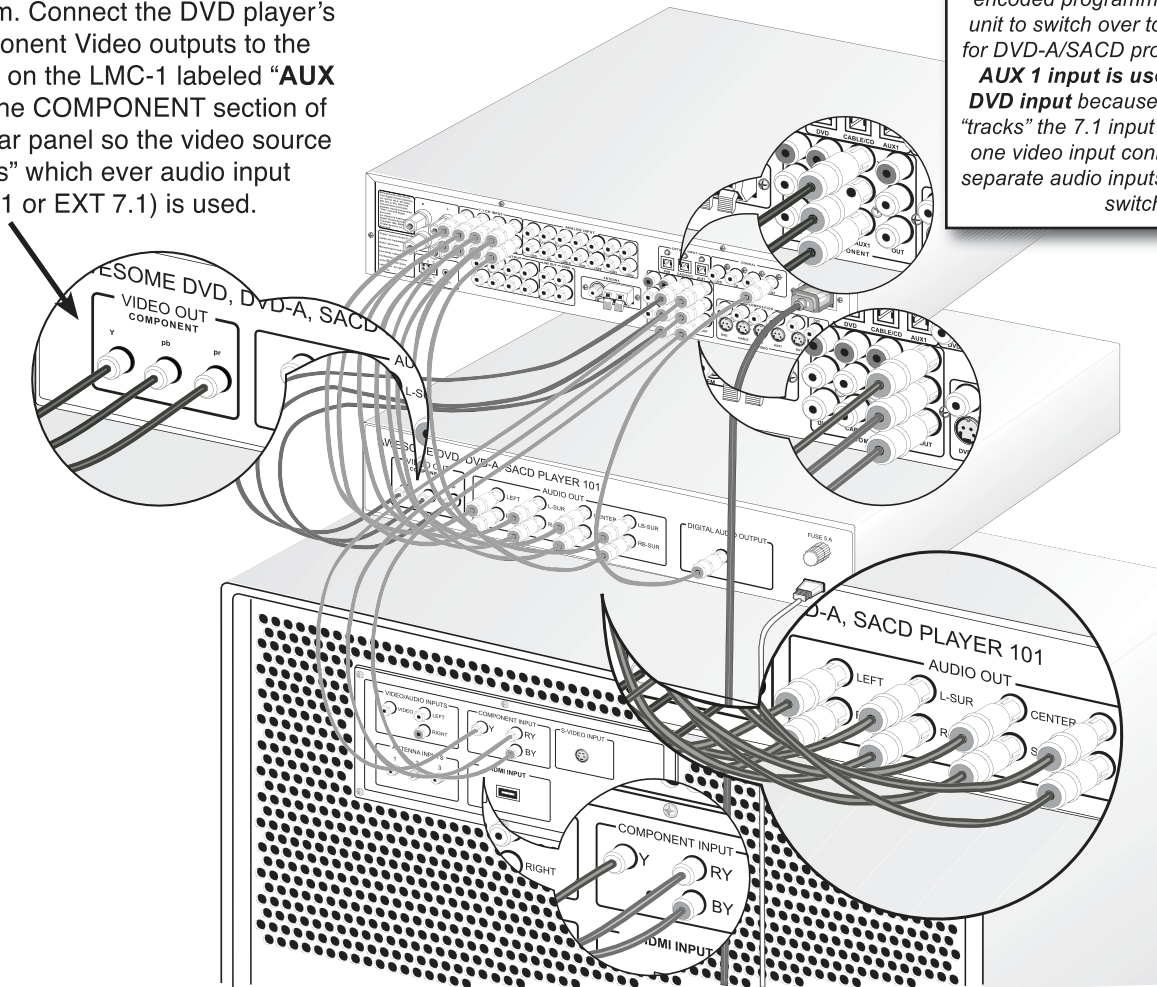

A Note About Universal DVD Players

Digital audio connections through **AUX 1** are shown for a "universal" player that serves both DVD-A and DVD-V functions. The DVD-V portion uses a digital connection for the Dolby and DTS encoded programming, but allows the unit to switch over to the **EXT 7.1** input for DVD-A/SACD program material. The **AUX 1** input is used instead of the **DVD** input because AUX 1 video input "tracks" the 7.1 input as well. In this way, one video input connection serves two separate audio inputs with out additional switching.

7.1 Channel Analog Audio

This audio connection type is specifically for post processed delivery of DVD-A or SACD source material (or for Dolby/DTS programming where the decoder is external). The connections are simple - just connect each labeled RCA audio channel from the source component to the corresponding input on the LMC-1 in the 7.1 CHANNEL connector block. If your source component does not have "BACK" surround outputs (LBS and RBS), simply connect what is available. That should be at least Left Front, Center, Right Front, Left Surround, Right Surround, and Subwoofer (SW).

Please note: If your multi-channel analog audio source component also serves as your DVD-Video or CD player (as many combination "multi-format" players do), you may also choose to connect its digital audio output to the AUX 1 input on the LMC-1 so that you can listen to those source formats appropriately and still "see" the same video images. In this case, you would connect both the 7.1 outputs to the 7.1 Channel input of the LMC-1 AND the coaxial or optical digital output into the AUX 1 input of the LMC-1. When you play DVD-Video or audio CD's you would select AUX 1. When you play DVD-A or SACD, you would select the EXT 7.1 source input., but the video source input will "track" the AUX 1 input meaning the video image will remain when you switch between AUX 1 and EXT 7.1. This is the best way to utilize the "Universal" DVD player.

Connecting a Cable Box or DSS Receiver

Connection of the Cable Box or DSS Receiver

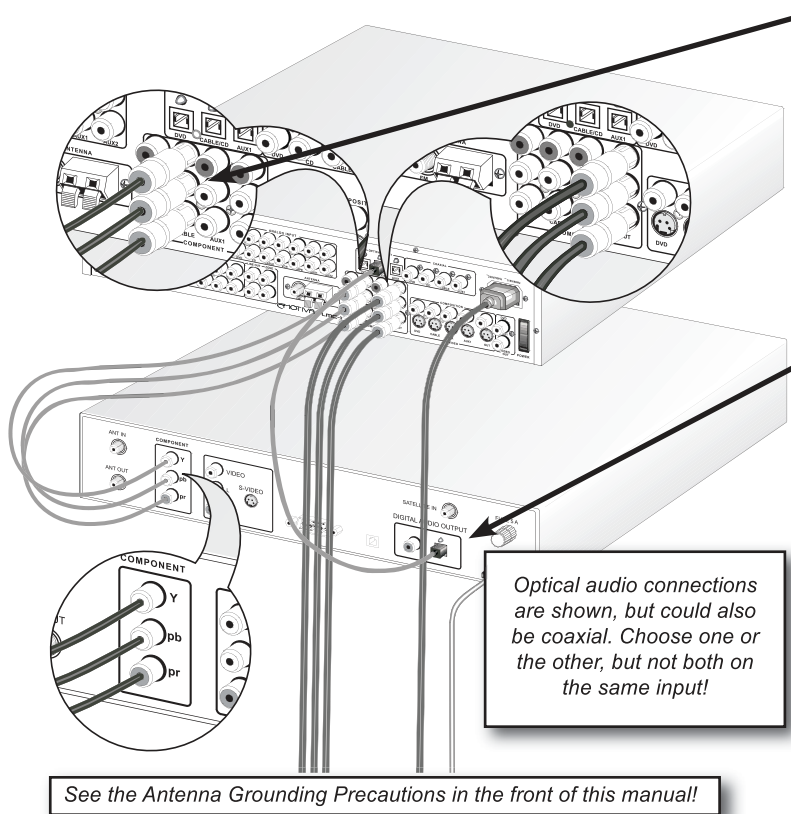

Component Video

If it is available from your cable or satellite provider, This video connection type provides the best visual resolution and is necessary for HDTV resolution. Connect the Cable Box or DSS Receiver's Component Video outputs to the inputs on the LMC-1 labeled "CABLE" in the COMPONENT section of the rear panel. If your Cable Box or DSS Receiver does not have Component Video outputs available, choose S-Video next and then Composite Video.

Digital Audio

This audio connection type provides the best audio resolution and is necessary for decoding discrete Dolby Digital and DTS source material and is especially important for HDTV programming because many are broadcast in 5.1. Connect the Cable Box or DSS Receiver's optical digital or coaxial digital output to the appropriate input on the LMC-1 labeled "CABLE". It does not matter whether you use coaxial or optical connections as far as audio clarity goes, only that the correct input type is assigned in the setup process. If your Cable Box or DSS Receiver does not have digital audio outputs available, choose analog RCA audio instead and assign the input accordingly.

Connection of a HDD, DVR, or TiVo Type Device

A/V Connections to a HDD/DVR device

There are many ways in which a digital recording device can connect between the cable box or DSS receiver and the LMC-1. The main thing to consider is that the last device in the signal chain will connect into the LMC-1. This last device is usually the HDD or DVR device because the content from the cable box must first "pass through" the HDD or DVR device for recording and then into LMC-1 for video display and audio processing. Check your HDD or DVR instructions for specific connection configurations.

This example represents a common HDD/DVR set up where the cable box has S-Video and digital audio outputs that connect to the inputs on the HDD/DVR device. In turn, the HDD/DVR output connects into the LMC-1 in the digital audio and S-Video inputs labeled "CABLE". This example also shows a Component Video output to the television which demonstrates how the LMC-1 video upscaling feature can be used.

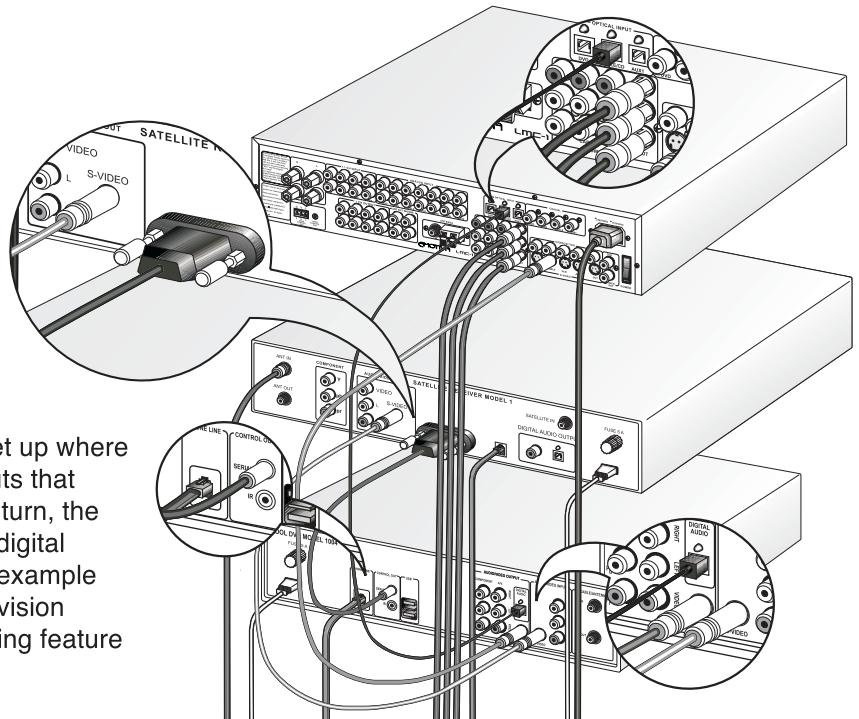

Connecting a Tape Player or VCR

Connection of the Tape Player

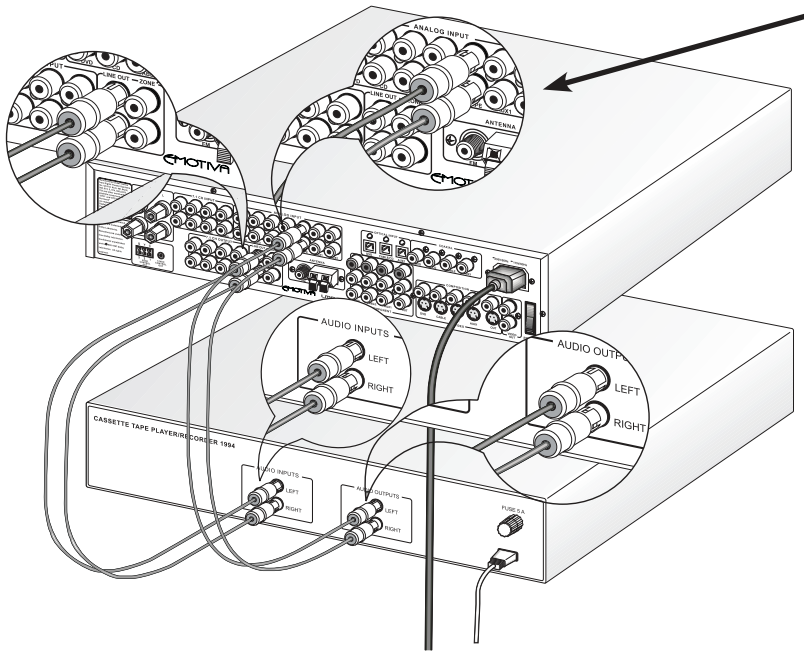

Analog Audio Connections

Connect the tape player's "INPUT" or "LINE IN" jacks to the LMC-1 "LINE OUT" RCA jacks. Then connect the tape player's "OUTPUT" or "LINE OUT" jacks to the LMC-1 "TAPE" RCA jacks in the input section.

This configuration allows any audio to pass from the LMC-1 line outputs into the tape player and then back into the input of the LMC-1 for playback.

Note for Tape AND VCR users:

If you are using a VCR in addition to this tape player, you may need to either use a "Y" adapter on the **LINE OUT** of LMC-1 or pass audio through one device first, then on to the other, then each will connect to their respective inputs back on the LMC-1 (TAPE and VCR).

Connection of the VCR

Analog Audio Connections

This connection diagram shows the VCR analog RCA audio outputs connected into the audio input RCA jacks on LMC-1 labeled "VCR". Since there is no digital output capability for VCRs, you need not worry about assigning the input. LMC-1 immediately recognizes the analog RCA audio jacks as the only audio input. If you are connecting the LMC-1 outputs to the VCR, see the note above in the Tape Player connection for your options.

Video Output/Input Connections

The output of the VCR back into LMC-1 is shown as Composite Video but could also be S-Video. Output from LMC-1 into VCR is ONLY Composite Video. The "VIDEO OUT" jacks both output Composite Video signals from any source input using S-Video or Composite Video (see note for Component Video recording).

The output of the LMC-1 into the TV is shown as Component Video because this is a common connection that the LMC-1 makes possible with the internal video upscaling feature.

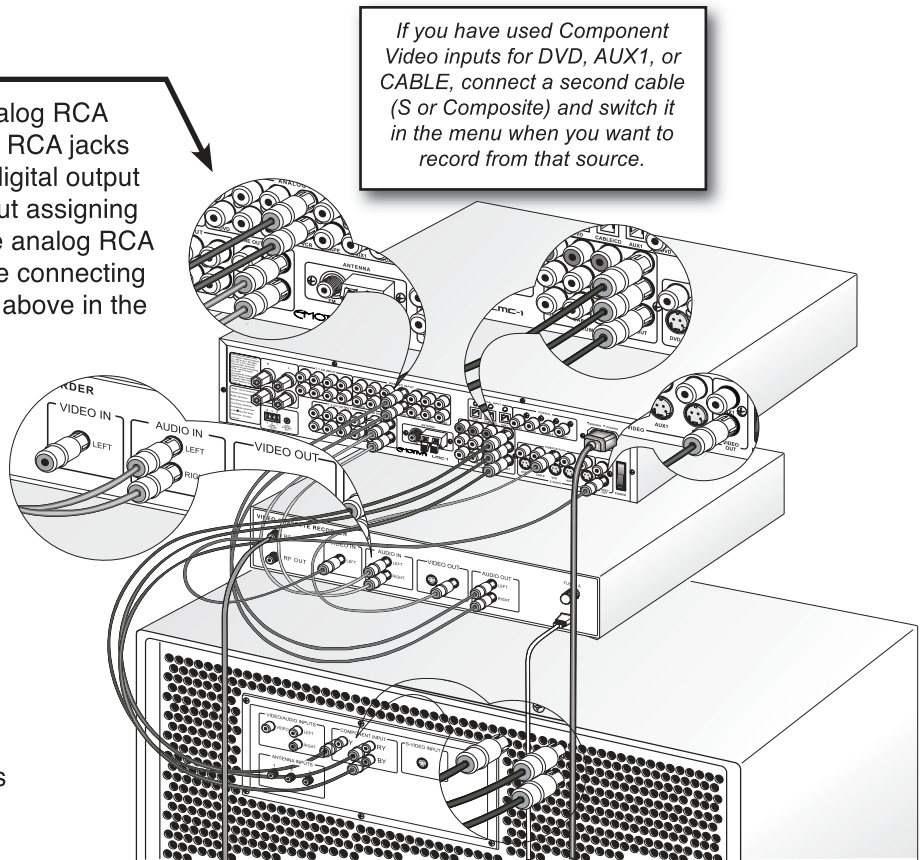

Connecting Auxiliary Sources

Connection of the AUX 1 Input

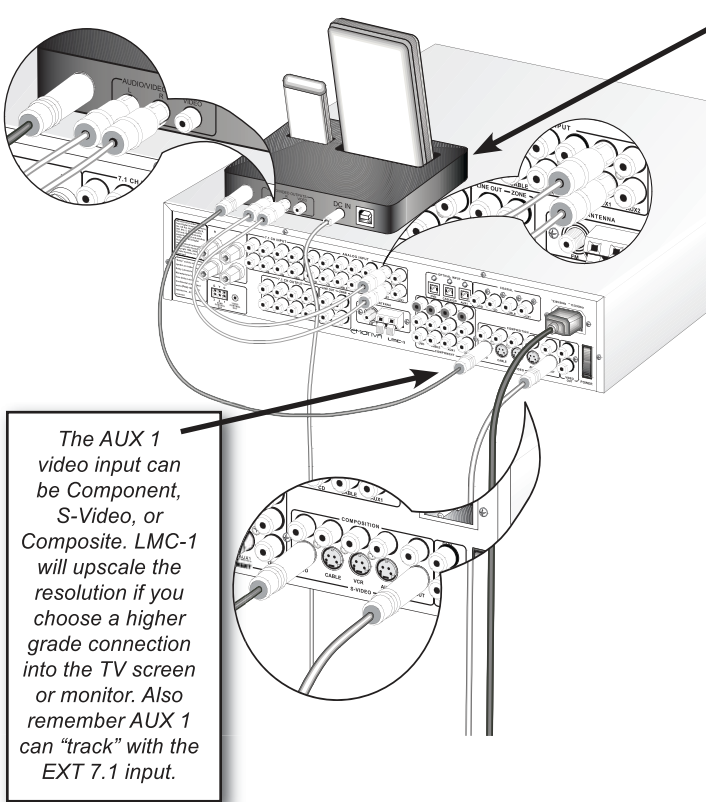

Auxiliary A/V Device Connections (AUX 1)

There are several options for connection of external A/V devices to the AUX 1 inputs depending on the configuration of the device. There are assignable digital inputs on AUX 1 (either optical or coaxial) or you can connect analog audio RCA inputs as shown here. There is also a choice of video inputs (Component, S-Video, or Composite) on LMC-1 for AUX 1 inputs which makes this input suited for just about any modern entertainment device. Remember, when you select the EXT 7.1 input for audio, it will display whatever video is present on the AUX 1 video input because EXT 7.1 "tracks" video with this input even though audio switches from AUX 1 inputs.

iPod Docking Station

Our example shows an iPod docking station with wireless remote (also docked) that has RCA outputs on the back of the dock which connect into the RCA audio inputs on LMC-1 labeled "AUX 1". Many portable compressed media players also feature a video output for photos, movies, etc. which would necessitate a video connection as well. This example also shows the S-Video output of the docking station connected to the S-Video input jack on LMC-1 labeled "AUX 1".

Just think about all of the possibilities you have for an AUX 1 A/V source!

Connection of the AUX 2 Input

Auxiliary Audio Device Connections (AUX 2)

LMC-1 is limited to "analog audio only" inputs in the AUX 2 position. There is no digital audio input capability and there is no video input either. If you have an auxiliary device to connect that requires digital audio or video inputs, consider placing that into the AUX 1 position. There is no need to assign the audio input type on AUX 2 because there is only one choice, analog RCA audio.

Satellite Radio Docking Station

Our example shows a satellite radio docking station that has RCA outputs on the back of the dock which connect into the RCA audio inputs on LMC-1 labeled "AUX 2". Many satellite radio controllers (for either Sirius or XM) are able to be moved from car to home when used with a home docking station and - in most cases - an indoor satellite radio antenna for reception. Although the configuration of the dock may vary from model to model, the idea is to connect the RCA audio outputs into the LMC-1 as an AUX 2 source input and enjoy the same satellite radio programming you have in your car.

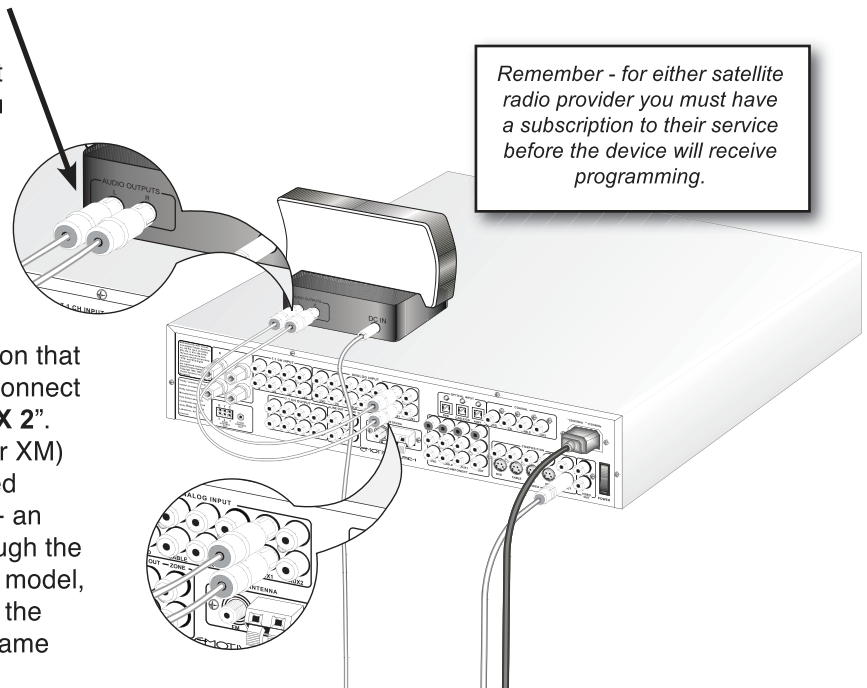

Connecting Antennas and External Amplifiers

Connection of the AM and FM Antennas

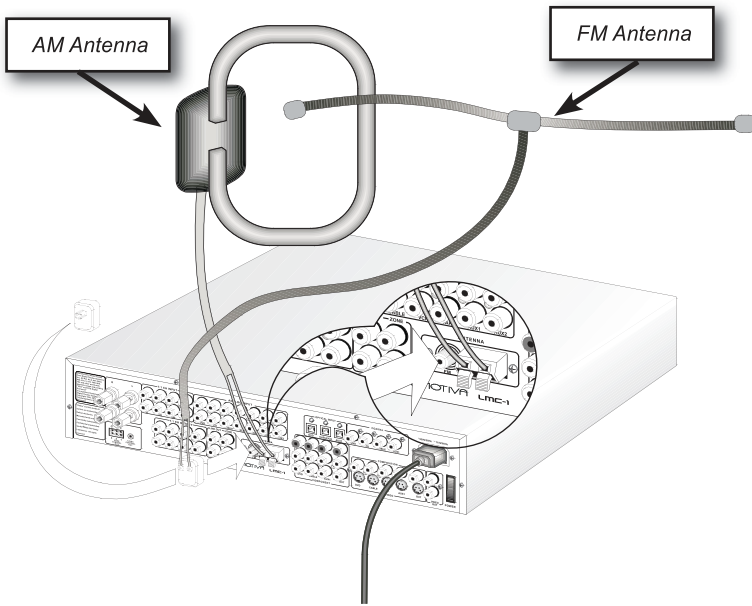

AM and FM Antenna Connections

Connection of the AM and FM antennas should be very simple.

AM Antenna

Connect the two wire ends of the AM loop antenna to the spring loaded terminals at the back of the LMC-1. The position of the wires is not important, simply that they are connected as they form the "loop" for adequate AM reception. The base of the loop should be snapped on to the antenna and then you can experiment with the optimum location.

FM Antenna

Attach the two wires of the end of the FM antenna to the "F-Connector" adapter and push the connector on to the FM antenna input. The highest unobstructed location (as shown) possible will yield the best FM reception.

Connection of the 7.1 Channel Preamp Outputs

Main Zone 7.1 Channel Connections

Connect the RCA audio outputs of LMC-1 in the "7.1 CH OUTPUT" section of the back panel to the appropriate inputs on one or more amplifiers to handle your configuration. This connection diagram shows the LMC-1 paired with the companion Emotiva 7 Channel LPA-1 amplifier, but your configuration could vary depending upon the number of discrete channels you must power and how many amplifiers required to do so.

The outputs connect as follows:

- L = LEFT FRONT
- R = RIGHT FRONT
- C = CENTER FRONT
- LS = LEFT SURROUND
- RS = RIGHT SURROUND
- LBS = LEFT BACK SURROUND
- RBS = RIGHT BACK SURROUND
- SUB = SUBWOOFER (LFE Channel)

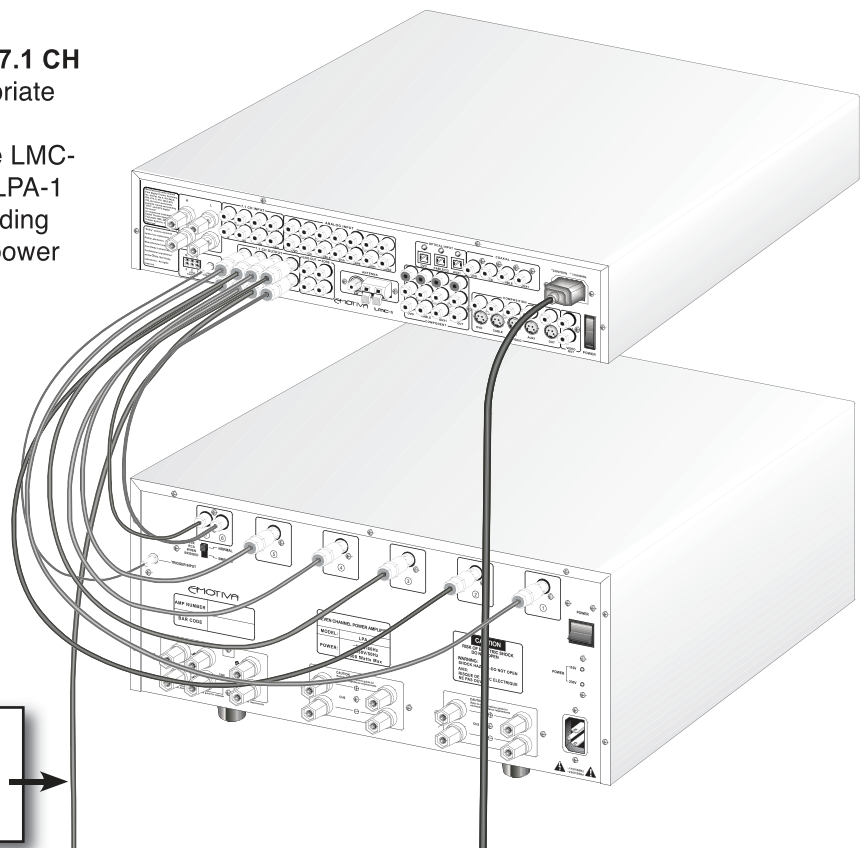

The SUB output will connect either into an amplifier or to a powered subwoofer (with the amplifier built in).

Zone 2 Connections

Connection of the Internal Zone 2 Amplifier

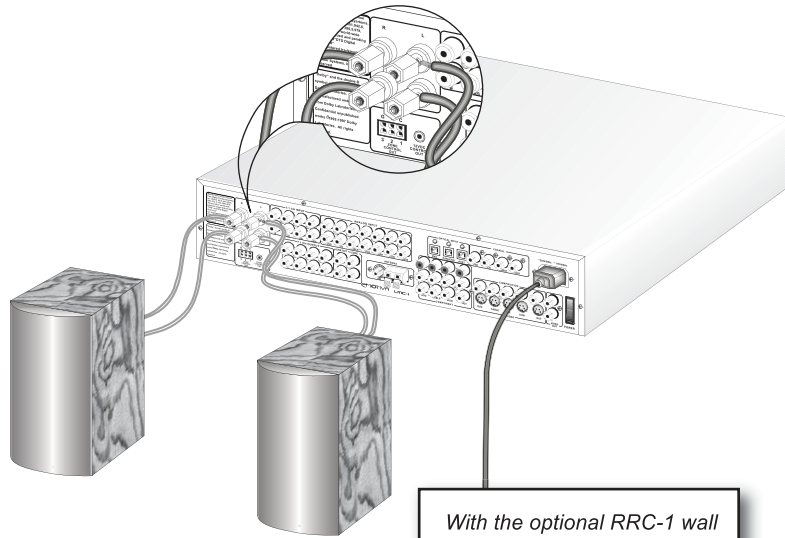

With the optional RRC-1 wall plate connected to LMC-1, you can control volume, source, and mute functions from the room in which the speakers are installed.

Zone 2 Connections (On Board Amplifier)

This diagram shows two speakers connected directly to the Zone Amplifier Outputs of the LMC-1. These could be any speakers whether it be bookshelf type (as shown), in-wall, in ceiling, or even outdoor speakers if the second zone is for a patio or outdoor area.

First prepare the wires by stripping back 3/4" of the insulation and unscrewing the 5 way binding posts. Then connect the left speaker wiring to the "LEFT +" and "LEFT -" terminals on the back of LMC-1. Connect the right speaker wiring to the "RIGHT +" and "RIGHT -" terminals. Be sure to observe correct polarity so that the positive terminal connects to the positive terminal at the speaker.

If for some reason you have connected these incorrectly, you will notice a distinct cancellation that lacks low frequency response once you play music through the speakers. If this is the case, double check your connections!

Connection of the Zone 2 Preamp Outputs

Zone 2 Connections (External Amplifier)

Connect the RCA audio outputs of LMC-1 in the "ZONE" section of the back panel to the input of a 2 channel amplifier that connects to the speakers in the second zone. This connection diagram shows the LMC-1 paired with a Emotiva BPA-1 amplifier that is set for 2 channel operation. The actual amplifier could be any 2 channel amplifier so long as it meets the power requirement that you wish to have in Zone 2.

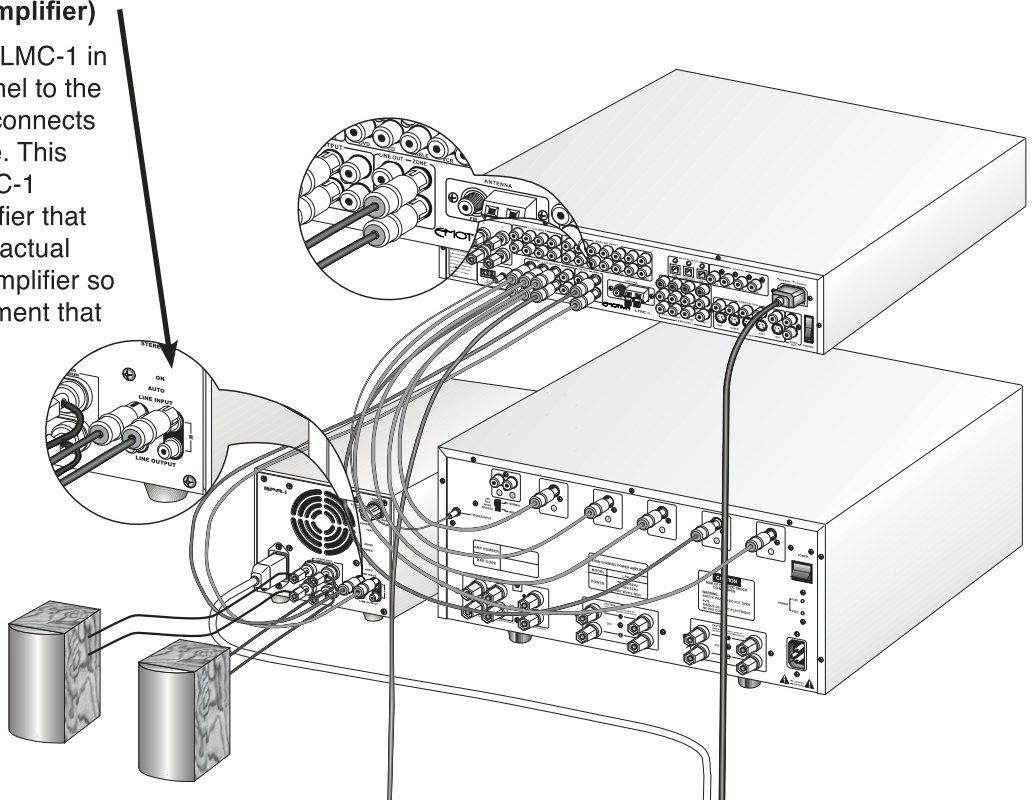

If you will be installing Zone 2 speakers in a location far away from the LMC-1, it may be better to install a dedicated amplifier for the best results. This is especially true of applications such as outdoor speaker locations. In these cases, install the Zone 2 amplifier closer to the speakers than to the LMC-1 for the best power transfer.

RRC-1 Wall Plate

Description of the RRC-1 Wall Plate Accessory

How the RRC-1 Works:

The RRC-1 Wall Plate is an easy solution to control the Zone 2 functions of the LMC-1 from a remote location.

To turn Zone 2 ON from the RRC-1 wall plate, press the **"POWER"** button on the right side. Repeat this step to turn Zone 2 back OFF.

To select a source component, press **"INPUT"** to scroll through the available inputs (CD, DVD, CABLE, VCR, TAPE, AUX1, AM, or FM). If select **"SYNC"**, the Zone 2 source becomes a digital down mix of the same input source as the one selected for the Main Zone.

To adjust volume, press **"VOLUME +"** or **"VOLUME -"** on the wall plate until you achieve the desired volume. To mute the Zone, press **"MUTE"** on the RRC-1 wall plate.

RRC-1 Wiring:

The RRC-1 installation is a simple 3 wire installation. The 3 terminals on the back of the RRC-1 keypad connect directly to the same 3-2-1 labeled terminals at the back of the LMC-1 using existing wiring provided it is not already used for speakers, telephone, internet, or other electronic devices.

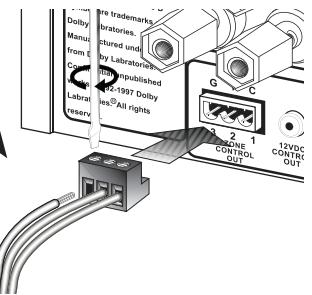
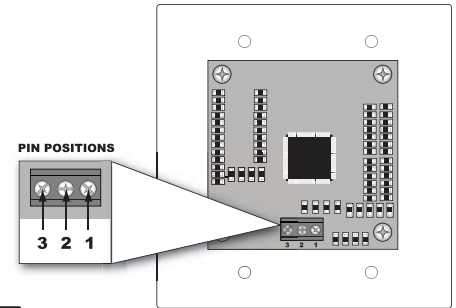
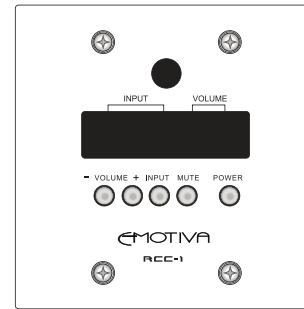

Installing and Connecting the RRC-1 Wall Plate Accessory

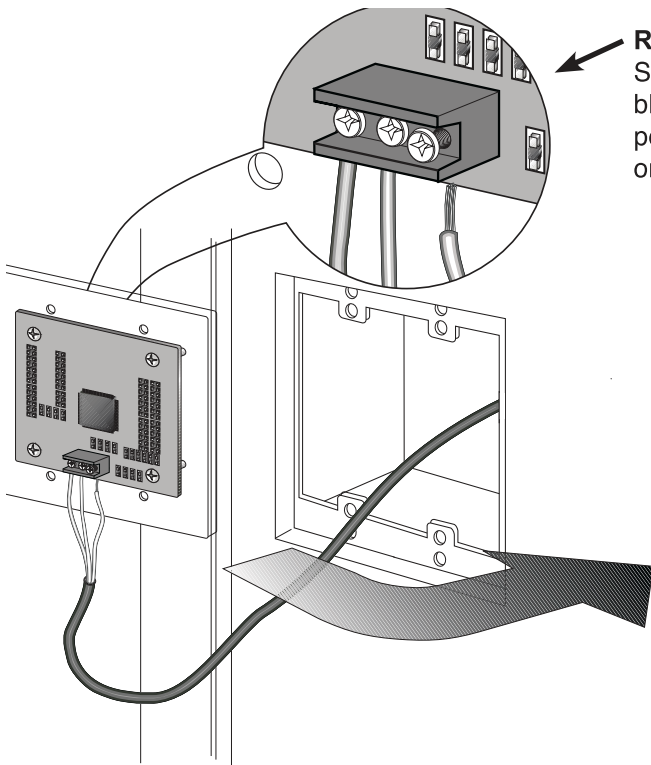

RRC-1 Wall Plate Installation:

Strip each wire about 1/4" and insert in the RRC-1 connector block observing the correct positioning with LMC-1 numeric position (Pin 1 on LMC-1 should go to pin 1 on RRC-1, and so on). Tighten down the set screws to secure each wire in place.

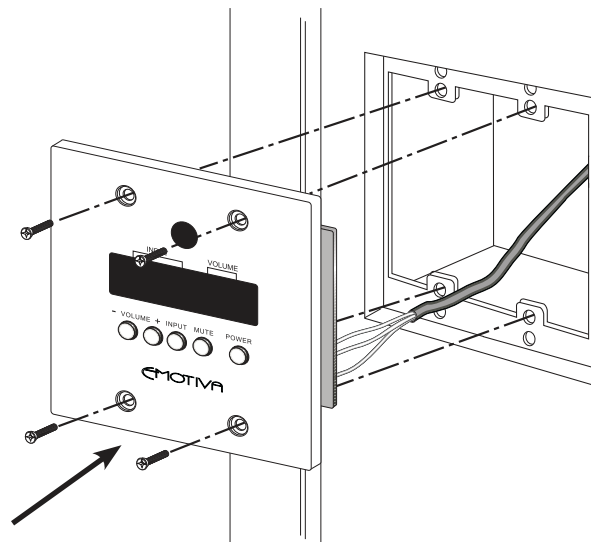

Next, position the wall plate up against the trim out ring in the drywall or wall opening and attach with 4 screws. The RRC-1 should be ready for operation.

Quick Setup of the LMC-1

The LMC-1 is rather deceiving in the respect that the front panel simplicity has just two control knobs, a power button, and the front panel display. The simple layout does not convey the great flexibility of “behind the scenes” setup routines and programmable features. All of the programming CAN be done directly from the LMC-1 front panel, but for “Quick Setup” routines we encourage you to use the main remote control after the unit has been connected to a video display device. There are many discrete buttons on the remote that will get you where you want to go with just one or two button sequences. Most of the initial setup sequences only need to be done upon initial installation and then day-to-day use is literally a breeze.

A Note About “Learning” Remotes

As many home entertainment enthusiasts choose, you may elect to program the LMC-1 remote into a “learning” type remote that is the single (Master) control for all of your home entertainment components. In doing so, you can choose to omit certain setup functions if you wish so you do not inadvertently enter into those functions during normal use with the master remote. A master remote can also provide a unified turn on/off resource for all of the components in the system through the use of a macro program sequence.

Step 1 - After the LMC-1 is connected to the source components and the main amplifier(s), connect power to the unit by plugging the power cord. Make sure the AM and FM antennas are connected. At this time, be sure that all of your main room speakers have been connected to their respective amplifier channels with the Emotiva LPA-1 amplifier or equivalent amplifier(s).



Step 2 - Press the red **POWER** button in the upper right corner of the LMC-1 remote to turn on the component. At this time, you must also power up the amplifier(s), other source components, and the video display device (your TV, projector, etc.). Verify all components are on before proceeding.

Step 3 - Lower the **volume** of the LMC-1 to around “10” so the sound level does not accidentally overpower the speakers. Then choose AM/FM as the source selection. This will get sound to the speakers immediately. Some of the other source inputs likely need to be configured properly before use. Use this time to make sure all speakers are working.

Step 4 - Next, insert a DVD and press **PLAY** on the DVD-Video player of the system to get started. In our example, we will begin with configurations with the DVD player, but you could begin with whatever component you choose, just alter the quick start steps for the source accordingly.

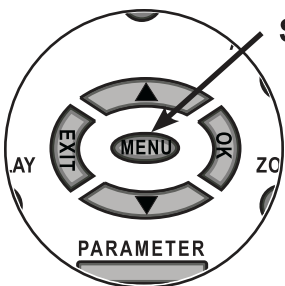

Step 5 - Press **MENU** on the LMC-1 remote to go to the **Input Select** menu on the OSD. Begin by selecting the first component you have connected (this example will be for DVD). This selection process will be repeated for EACH source component you have connected that needs configuration.

Step 6 - From the OSD **Input Select** menu choose DVD, then press “OK”. Next you will see the defaulted selections for both **Audio** and **Video** inputs for the DVD source. The menu defaults to **Audio**.

Step 7 - To select the **Audio** source, press “OK” to toggle the input selections. Each time you press “OK”, the selection will advance to the next choice. When you have chosen the correct audio input (and you begin to hear audio), toggle the “**MENU DOWN ARROW**” key to the **Video** selection.

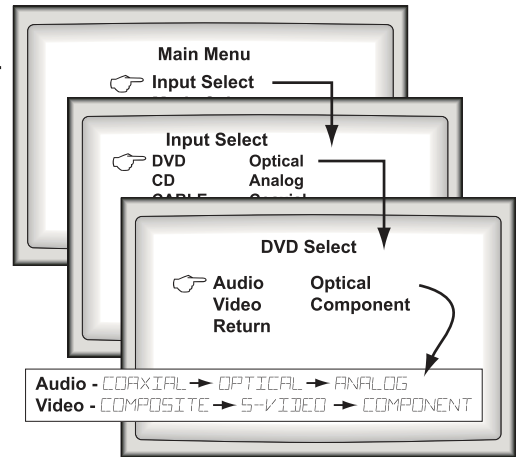

Step 8 - To select the **Video** source, press “OK” to toggle the input selections. Each time you press “OK”, the selection will advance to the next choice. When you have chosen the correct video input (and the picture appears on screen), press “EXIT” or select **RETURN** from the OSD.

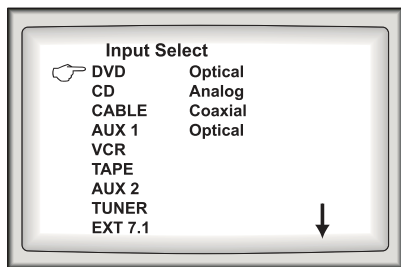

Continue to configure all applicable source inputs (either audio, video, or both) until all sources have been configured

Step 9 - Repeat the source input configurations from the **Input Select** menu for EACH COMPONENT you have connected in the system at this time that has selectable audio or video inputs.

Step 10 - With the basic input configurations completed, you are now ready to enjoy all the default features of the LMC-1. For additional details on configuring individual speaker sizes, surround channels, Zone 2 parameters, OSD choices, and other selectable parameters, please see the subsequent “**LMC-1 Programming and Calibration**” section.

If you have gotten to this point and you are able to hear sound in all speakers and see the video portion of your source input, you have most of the work done. If for some reason all speakers are not playing or there is some other problem, please check the troubleshooting section of the manual to narrow down your problems before moving along.

For complete configuration instructions of your Emotiva LMC-1, please read the next section - “LMC-1 Programming and Calibration” - thoroughly.

LMC-1 Programming and Calibration

To engage any of the setup or programming menus, you can either select “MENU” from the LMC-1 remote control or push the left control knob on the front panel. The word MENU will flash on the front panel display twice and default to the first menu selection (the Input Select Menu). If the LMC-1 is connected to a video display device (TV, projector, etc.) the On Screen Display (OSD) will also appear showing the MAIN MENU screen. Each programming step can be completed either on the front panel controls or by using the remote and the On Screen Display (OSD). Once you get to the MAIN menu, you will be able to program each of the menus before moving on to calibrating and fully enjoying your LMC-1 preamplifier.

Navigation on the Front Panel



The front panel display of the LMC-1 will indicate most all of the same menu choices as the OSD, but longer selections will scroll from right to left

The programming and setup of LMC-1 via front panel control is done exclusively with the silver control knob on the left side of the unit called the “FUNCTION KNOB”. This knob has 3 basic functions:

- Push In
- Scroll Up
- Scroll Down

When you push the knob in, the front panel vacuum fluorescent display flashes “MENU” twice and then defaults to the first menu selection (the Input Select menu). Once the menu selection is displayed, the SCROLL UP/DOWN function allows you to switch between the various menu items.



If you push in the knob again, the menu item becomes active and it will take you into that particular menu. The front panel vacuum fluorescent display will indicate the menu item chosen depending on the specific parameter you are adjusting.

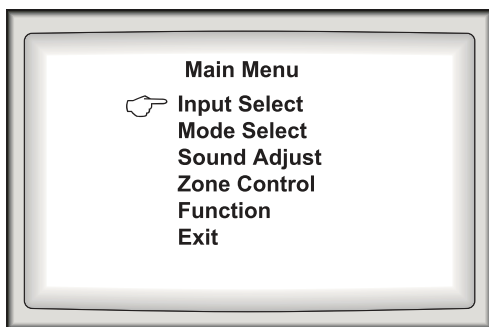

Navigating the OSD with the Remote

Navigation functions available via remote can be tracked visually using the front panel vacuum fluorescent display, but it’s **much easier and convenient to use the OSD** to see where you are in the adjustment process. Each menu function can be selected by the UP/DOWN arrows in the center of the remote and with the OK button to the right of the MENU button.

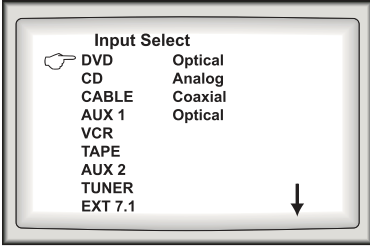

Input Select Menu

Using the Inputs Menu, you can specify the input configurations of each source type so your entertainment value of the LMC-1 is always maximized with the best possible sound and visual qualities. To access the inputs menu, choose “MENU” from the remote, then “INPUT SELECT”, then press “OK”

Audio Inputs

Based on your physical connections on the back of the LMC-1, you must assign the input to a particular source where choices apply. This means that you must tell the LMC-1 on which input to seek an audio signal in DVD, CD, CABLE, or AUX 1 modes. The choices you have are:

- **Analog** (the Red/White RCA jacks)
- **Coaxial Digital** (the single Orange RCA jack)
- **Optical Digital** (the TosLink jack)

Whenever possible, try to use the coaxial or optical digital inputs because these will carry any encoded multi-channel audio format such as Dolby Digital or DTS. Without the digital audio connection connected and assigned on these inputs, true multi-channel encoded signals will not be available. The VCR, TAPE, AUX 2, EXT 7.1 audio inputs **only have analog audio connections** available so there is no need to assign the input type. Although these sources (including TUNER) will appear on the front panel display of the inputs menu, the audio input is fixed on analog.

Video Inputs

As with the audio inputs, there are certain video source input assignments necessary for the LMC-1 programming. The DVD, CABLE, AUX 1, and VCR each have input assignments. The choices you have are:

- **Composite Video** (the single yellow RCA jack)
- **S-Video** (the mini multi-pin round jack)
- **Component Video** (the Red/Green/Blue trio of RCA jacks)

Wherever possible, try to use the Component Video connections (except for the VCR input where only S-Video and Composite are available). The Component Video connections are compatible with wide bandwidth HDTV signals and will provide the best possible picture quality. If you must use the S-Video or Composite inputs for the DVD, CABLE or AUX 1 sources, the LMC-1 has a video up-conversion feature that will output a 480i signal on the Component Video outputs to your television or video display screen. When selecting Component Video for a source input, the OSD will display against a blue screen whenever it is active to maintain the highest signal purity for the video path.

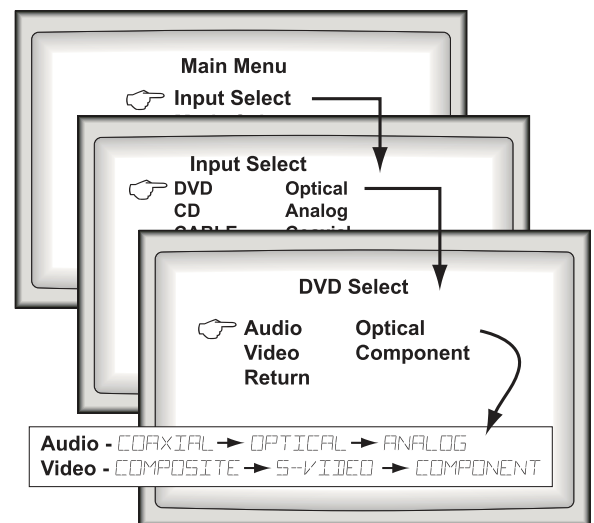

This input menu sequence shows the configuration choices for the DVD source inputs.

Mode Select Menu

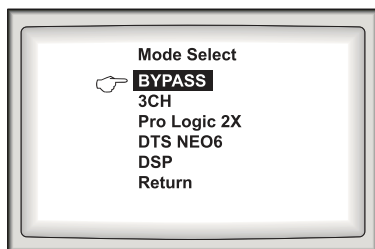

The Mode Select menu of the Emotiva LMC-1 offers the user an unparalleled opportunity to hear both music and movie soundtracks in their format of preference based on both their listening style AND the configuration of the source inputs and speakers in the system. The LMC-1 uses intelligent processing to display only the modes that the system can accommodate, thereby reducing the possibility of errors on the part of the user. Please note that for any digital signal source, you must set the output to BITSTREAM mode so the LMC-1 will handle the digital signal decoding or processing chores - otherwise the bypass modes may not respond properly.

Bypass Mode

Whenever “Bypass Mode” is selected, the LMC-1 bypasses all signal processing and/or decoding functions and reverts to a “pass through” type 2 channel mode. This is preferred by some 2 channel enthusiasts so that the original qualities of a 2 channel recording can be preserved or if the user wishes to bypass decoding of a Dolby or DTS soundtrack and run in 2 channel PCM format.

To select the Bypass Mode, simply press the “BYPASS” button near the top left side of the LMC-1 remote control.

Dolby Modes

There is a built in Dolby decoder in the LMC-1 that is capable of the following modes:

Digital Modes

Dolby Digital (AC-3), Dolby Digital EX

Matrix Modes

3 CH, Dolby Pro Logic IIx

The modes will be available according to the source input selection (including the configuration of the audio input) and the channels that have been enabled through the Speaker Selection within the Function Menu. If, for example, you have selected a center channel speaker but you do not enable rear channel speakers, you would be able to use the 3 channel selection but you will not be able to select Dolby Pro Logic IIx. As another example, you may be watching a DVD-Video movie and have elected to use the analog (RCA) inputs. If this were the case, the OSD would not show “Dolby Digital” modes because there is no digital input. In this way the LMC-1 is intelligent because it will not allow selections of sound enhancement modes that do not have the “foundation” in place to properly implement the selection.

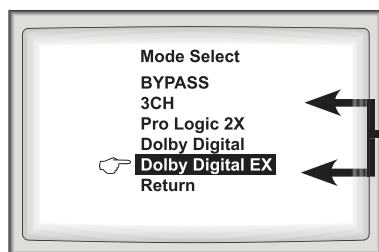

Example showing Tuner Menu screen

The modes that are displayed in the “Mode Select” menu will be determined by the source input signal and the speaker configuration. If some selections do not appear on the menu, it’s because the source format does not support them (i.e. the DVD-Video disc may not support DTS so DTS selections do not appear), the input is analog when it should be digital (or digital set to “BITSTREAM”) or speakers are not configured to support that selection (i.e. you have not enabled the rear channels so Pro Logic 2X will display but not engage). BYPASS mode is ALWAYS available.

DTS Modes

There is a built in DTS decoder in the LMC-1 that is capable of the following modes:

Digital Modes

DTS, DTS-ES

Matrix Modes

DTS Neo:6

As with the Dolby modes, the LMC-1 will only display the available DTS modes based on the source input selection (and the configuration of the audio input) as well as which speakers have been selected. Furthermore, since not all DVD-Video discs offer DTS capability, the “DTS” and “DTS-ES” selections are only available with DVD’s that offer DTS playback.

Both Dolby and DTS matrix modes offer various selections for the appropriate signal source. DTS calls their theater format “Cinema” while Dolby Pro Logic 2X calls it “Movie”. For listening to music selections, you can choose Pro Logic 2 “Music”, “Virtual”, or “Matrix” where with DTS your choices are called “5 Channel Music” or “6 Channel Music”. Any of these modes can be chosen as long as they are displayed and surround channels are enabled, but the names indicate where one might be better for movies while others for music. Try them all to see what you prefer. Matrix is especially effective as a “Party Mode” type music or football game resource because the left and right channel sound is spread across all active speakers.

DSP Modes

There is a built in DSP soundfield processor in the LMC-1 and there are a total of 8 different DSP modes available. DSP is the process of adding reverb and time delay effects to the audio content to simulate the sound effect you would experience in specific spaces such as a church, movie theater, sports stadium, or an intimate jazz club. DSP effects are available if the input signals are from the following source inputs and configurations:

- DVD, CD, CABLE, AUX1 (either via Analog RCA input or Digital input using PCM format)
- VCR, TAPE, AUX2 (using the Analog RCA input)
- AM/FM TUNER (this audio connection already occurs internally)

When selecting a DSP mode, you have 8 choices:

- LIVE
- STADIUM
- CHURCH
- HALL
- THEATER
- ROCK
- POPS
- CLASSIC

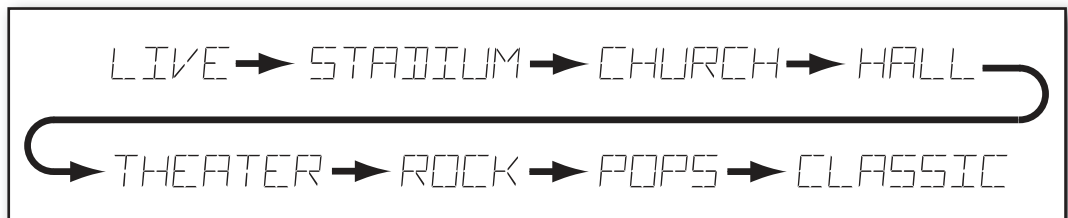

To select the DSP modes from the remote control, simply press the “**DSP**” button on the remote control to engage the first DSP effect. Continue pressing the DSP button to scroll through each of the 8 modes. If you want to cancel the DSP effect, you can simply hit “**BYPASS**” to go back to a 2 channel operation or the “**DOLBY**” or “**DTS**” buttons to return to whichever of those modes you previously had running.

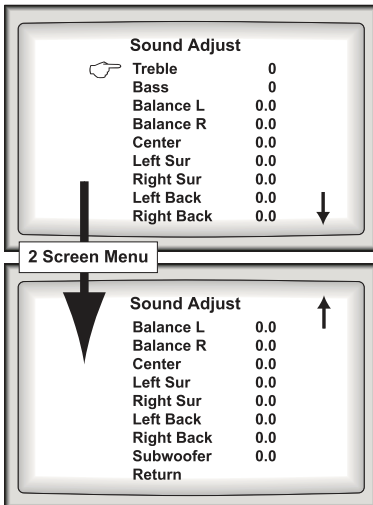

Example showing full Sound Adjust parameters. This takes 2 screens.

Sound Adjust Menu

The Sound Adjust Menu is intended to allow you to fine tune the LMC-1 operation to overcome the restrictions that may be inherent in furniture/speaker placement, reflective surfaces in the room, seating positions, or multiple subwoofers. Each sub menu is described for the parameter it affects and how it is adjusted.

Bass and Treble Adjustment

You can adjust both the bass and the treble of the main channels by selecting “**BASS**” or “**TREBLE**” on the remote control and using the “**VOLUME UP/DOWN**” buttons on the remote to adjust the levels of bass or treble. Bass and Treble adjustments have a range of -10dB to +10dB and they go in 2dB increments.

Please note that some DSP modes manipulate the bass and treble adjustments as part of the sound effect, so if you have chosen one of those modes and go to adjust bass or treble you may find the setting different than when it was set in Bypass, Digital, or Matrix Modes.

Balance Left and Right Adjustment

You can adjust balance of the left and right main speakers by selecting “**PARAMETER**” on the remote control and using the “**MENU UP/DOWN**” buttons to select the left or right adjustment screen. Once you have selected the proper screen, use the “**VOLUME UP/DOWN**” buttons on the remote to adjust the balance. The balance adjustment has a range of -10dB to +10dB and it goes in 0.5dB increments.

Center and Surround Speaker Level Adjustments

The user may use this function to adjust the center or any of the surround speakers provided they have been enabled in the Speaker Configuration portion of the Function Menu. Each of the adjustments have a range of -10dB to +10dB and they go in 0.5dB increments.

Begin the level adjustment of center or surround speakers by selecting “**PARAMETER**” on the remote control and using the “**MENU UP/DOWN**” buttons to select which speaker you wish to adjust. Once you have selected the proper speaker, use the “**VOLUME UP/DOWN**” buttons on the remote to adjust the levels. When finished, select “**OK**” and return to the menu for the next parameter. After all the adjustments for center and surround levels are complete, select “**EXIT**” from the remote until the OSD disappears.

Subwoofer Level Adjustment

This adjustment allows you to change the relative output level of the preamp subwoofer output versus the overall main system volume. It is recommended that you first calibrate the levels of output on the subwoofer(s) along with any phase controls before making this adjustment. The range of adjustment is -10dB to +10dB (in 0.5dB increments), which should more than compensate for situations where multiple subwoofers are used or the single sub is loaded into a less than optimal location. Remember though, this output adjustment will not make a poorly designed subwoofer sound better, it will only help to fine tune what is already there.

You can adjust the subwoofer output level by selecting “**SUB**” on the remote control and using the “**VOLUME UP/DOWN**” buttons on the remote to adjust the subwoofer levels. Remember that the adjustment range of this parameter is -10dB to +10dB and it goes in 0.5dB increments.

Distance/Delay Settings

Instead of setting delays for the individual channels manually, LMC-1 automatically computes any needed delay for each individual channel based on the **distance setting** in the **Speaker Configuration menu**. Please see pages 35-37 for details.

Zone Control Menu

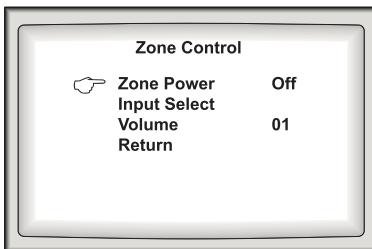

The Zone Control menu is specifically intended to control the operation of the Zone 2 outputs on the Emotiva LMC-1. The menu can turn the Zone 2 output ON or OFF, it can establish volume levels independent of the Main Zone, and it offers you a choice of input source selections. Please see pages 42-44 for detailed information on Zone 2 operations.

Please note that whenever Zone 2 is set to “ON” in the OSD menus or it is being used from the optional RRC-1 Keypad, the circuitry inside the LMC-1 will be “awake” even though the front panel lighting and display of the LMC-1 are not. This will cause the switched output (3.5mm jack) for external amplifiers to stay (or remain) active in the event there is an external Zone 2 amplifier. This is normal operation and will not harm the Main Zone amplifiers whatsoever.

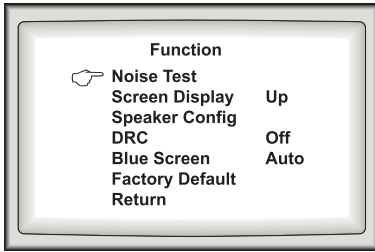

The Function menu is primarily for initial calibration of the LMC-1

Function Menu

The Function Menu on the Emotiva LMC-1 is used primarily for initial set-up of the unit. There are several functions such as selecting to enable/disable speakers, the position of parallel OSD functions (top or bottom of screen while viewing), pink noise channel level tests, factory reset, etc. In general, this menu is accessed upon set-up or when changes occur, but is otherwise not part of the day-to-day operation of the Emotiva LMC-1.

Noise Test

The Noise Test function is specifically intended for level matching the output of all the speakers in the system as closely as possible. Ideally you would use a sound pressure level meter to assist you in this task since it's hard for the human ear to easily distinguish sound differences below 3dB. The sound pressure level meter can easily help you to get within 1dB or less of output difference between each speaker and that will dramatically improve your listening experience.

Sound pressure level meters are available at most electronic supply stores (such as Fry's Electronics or Radio Shack) as well as through a number of credible internet based suppliers. The sound pressure level meter you choose need not be a high SPL or expensive unit, just something that can show you easy changes with a reference level of about 70dB while the Noise Test is engaged.

Setting up an SPL Meter

If you will be using a sound pressure level meter to calibrate speaker levels (which Emotiva recommends), place the SPL meter **at the listening position** at ear level with the microphone pointed forward at the center speaker on a 45 degree angle between horizontal and the ceiling. If you have the option of selecting the weighting and time response of the measurement, choose "C" weighting and "SLOW" response. Whether your meter is digital or analog, the slow response will minimize the guesswork on your part. Some technical documentation may suggest that you should turn the microphone around to point toward the surround speakers to calibrate those channels, but Emotiva feels this approach is somewhat redundant because, in the end, your head will remain in more or less the same listening position so the reference microphone should do so as well.

Performing the Level Calibration

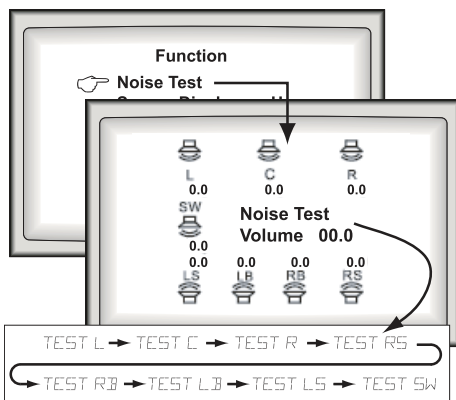

The Noise Test screen shows each speaker position and rotates clockwise around the screen.

When you are ready for the measurement, select the SPL range on the meter at 70dB. It's easiest to set the main volume at a reference level of about 75dB for this exercise before engaging the calibration process. To do this, activate the Noise Test feature from the LMC-1 remote by pressing the "TEST" button using the OSD as your guide. Adjust the main volume to about 75dB using the main volume control on the front panel (using front speakers as your reference) and then leave the LMC-1 volume control in a fixed position from this point on. Only the individual speaker level will be adjusted through the menu. Re-enter the Noise Test mode again by pressing "TEST" on the remote if you exit the test mode by adjusting volume.

Adjust each speaker to approximately a 75 dB reference. When you are adjusting speakers, make sure your body is not in a direct path of the speaker and make sure the listening area is quiet. When doing the calibration, only the test signal should be heard, so you should minimize HVAC noises, appliance noises, ceiling fans, children screaming, etc. as much as possible). The test signal will

remain in a fixed channel position for as long as you are making adjustments. Toggle the **"VOLUME UP/DOWN"** buttons while watching the meter to achieve the target setting. Once it's set, move the test signal to the next channel by selecting the **"OK"** button.

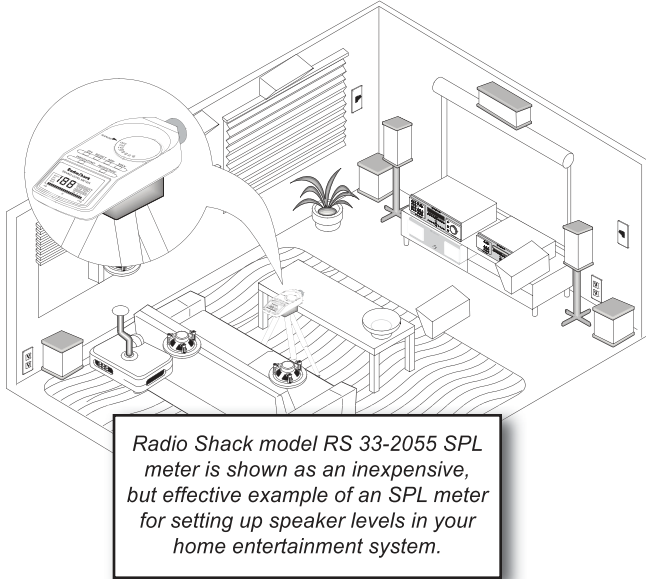

Radio Shack model RS 33-2055 SPL meter is shown as an inexpensive, but effective example of an SPL meter for setting up speaker levels in your home entertainment system.

If you have not selected center, surround, or rear surround channels, these channels will still be displayed on the OSD but not activate with any test signal. The active test signal flashes while the OSD is running so it's also a great opportunity to make sure the speaker making sound is the one indicated on the OSD. A simple mistake in connections at the audio outputs or with the amplifier could have a negative impact on your overall enjoyment of the entire home entertainment system.

If you are using a subwoofer, make sure it's selected as "YES" in the speaker configuration menu before making this calibration. If the subwoofer is not selected, the test signal will skip that channel in the rotation. When a subwoofer is used (which is most of the time) enthusiasts often prefer to give the subwoofer a small increase over the other speakers (say 3-5dB) so the low frequency effect is that much more entertaining. What you choose depends upon the size, power output levels, and amount of subwoofers you have. Any adjustments you make on the subwoofer should be done ON the subwoofer's level control itself. This way, you can always fine tune with the SUB menu of the OSD, but you will generally have the level set for most listening situations. Discrete LFE channel information already incorporates intelligent bass management so things like Dolby Digital and DTS movies should sound correct with low frequencies automatically if the proper sub levels have been set during calibration.

Screen Display

The Emotiva LMC-1 screen display for various OSD adjustments can be configured at the top or bottom of your screen, or you can configure it not to display adjustments at all.

- UP: The adjustment information will be displayed on the top of the display screen.
- DOWN: The adjustment information will be displayed on the bottom of the display screen.
- OFF: No adjustment information will be displayed on the screen except the OSD menus.

Begin the screen display adjustment by selecting **"MENU"** on the remote control and using the **"MENU UP/DOWN"** buttons to select **"FUNCTION, OK"**, then **"SCREEN DISPLAY, OK"**. Once you are in the screen display use the **"MENU UP/DOWN"** arrow buttons on the remote to make your selection. When finished, select **"OK"** and return to the menu, then select **"EXIT"** from the remote until the OSD disappears.

Speaker Configuration

SPEAKER SET		
MAIN CHANNEL	Small 20.0ft.	80Hz
CENTER CHANNEL	Small 20.0ft.	80Hz
SURROUND CHANNEL	Small 20.0ft.	80Hz
BACK CHANNEL	2CH Small 20.0ft.	80Hz
WOOFER	Yes	EXIT

The Speaker Configuration menu allows you to tell the LMC-1 exactly how things are set up in **your** home entertainment system. In doing so, you are allowing the intelligent operational characteristics of the LMC-1 to display and/or engage only the options that suit your speaker configuration and bypass any modes that do not apply. This not only simplifies day-to-day operation, but it also allows your speakers to play the way they were intended with the right balance of frequencies and (for surround channels) the effects of discrete encoding or matrix processing.

To enter the Speaker Configuration menu, press “**MENU**” on the remote control and using the “**MENU UP/DOWN**” buttons to select “**FUNCTION, OK**”, then “**SPEAKER CONFIG, OK**”. Once you are in the Speaker Set menu use the “**MENU UP/DOWN**” arrow buttons and “**OK**” on the remote to make your selections. When finished, select “**EXIT**” from the remote until the OSD disappears.

Several of the configurations will cause multiple reactions. For example, if you choose “**LARGE**” for the center channel, the surround channels can then be enabled and set to LARGE as well. In fact, the only way to enable LARGE surrounds is to select LARGE main **and** center. If you select “**NO**” for rear surrounds, you will not be given the option for selecting whether they are 1 or 2 channel operation - because that would be irrelevant. Pay close attention to the selections you make to ensure that any other automated settings for other speakers in the system are as you intended.

Main Speaker Set

You have a choice of SMALL or LARGE* for the front left and front right speakers. This sets the tone for the other speakers in the system because if SMALL is chosen, the LMC-1 will not allow any of the others to be mistakenly chosen as LARGE. This is particularly important for “bookshelf” or “cube” style speakers and it makes set-up go that much faster.

- If you select **LARGE***: The LMC-1 assumes the main speakers are capable of reproducing frequencies lower than 60Hz and the internal crossover is bypassed all together (even though you can still adjust it, there is no audible effect). Selecting LARGE also enables other speakers in the system to be assigned a LARGE designation if you choose.
- If you select **SMALL**: The LMC-1 assumes the main speakers are capable of only reproducing frequencies higher than 60Hz. The internal (HP) crossover point can be set between 60-150Hz. All other speakers in the system will only be capable of SMALL when this configuration is chosen.
- **DISTANCE** setting is between 0-20 feet for the main speakers. Choose a reference seating position for this setting and use the distance from this position to set the distance to the speaker.

** Please note that if you select LARGE for the main speakers, no information will be directed to the subwoofer from the “SW” output of LMC-1 on all Analog or PCM 2 channel source processing because the crossover is defeated in that setting (in other words there is no “low pass” information going to the SW output). Any discrete digital information with a dedicated LFE channel will still direct the “.1” information into the sub as normal. If you desire a separate subwoofer when using LARGE main speakers, Emotiva recommends using Y-adapters split from the main L and R channel outputs feeding both the amplifier for main speakers and a powered sub that utilizes an internal crossover.*

Center Speaker Set

You have a choice of SMALL or LARGE for the center speaker, or you can choose not to have one enabled at all.

- If you select **LARGE**: The LMC-1 assumes the center speaker is capable of reproducing frequencies lower than 60Hz and the internal crossover is bypassed all together. Please note that if you select LARGE, the surround speakers also default to LARGE.
- If you select **SMALL**: The LMC-1 assumes the center speaker is capable of only reproducing frequencies higher than 60Hz. The internal (HP) crossover point can be set between 60-150Hz.
- If you select **NO**: The LMC-1 assumes there is NO center speaker used in your system and when discrete center channel information is present the LMC-1 re-directs the center information into left and right channels.
- **DISTANCE** setting is between 0-20 feet for the center speaker. Choose the distance setting based on the seating position distance to the speaker.

Surround Speaker Set

You have a choice of SMALL or LARGE for the surround speakers, or you can choose not to have them enabled at all. For these to be enabled for LARGE, the main and center speakers must have been chosen for large as well.

- If you select **LARGE**: The LMC-1 assumes the surround speakers are capable of reproducing frequencies lower than 60Hz and the internal crossover is bypassed all together.
- If you select **SMALL**: The LMC-1 assumes the surround speakers are capable of only reproducing frequencies higher than 60Hz. The internal (HP) crossover point can be set between 60-150Hz.
- If you select **NO**: The LMC-1 assumes there are NO surround speakers used in your system and when discrete surround information is present the LMC-1 will simply ignore it.
- **DISTANCE** setting is between 0-20 feet for the surround speakers. Choose the distance setting based on the seating position distance to the speaker.

Back Speaker Set

You have a choice of 1 Channel or 2 Channel operation for the back surround speakers, as well as LARGE or SMALL settings, BUT you must have them enabled (in the Back SP selection) to have this menu item even displayed. For these to be enabled for LARGE, the main and center speakers must have been chosen for large as well. Also, you can't enable any back speakers if the surround speakers have not first been enabled.

- If you select **2CH**: The LMC-1 applies this selection for 7.1 speaker configurations where the back channel will be for a rear left and right speakers and where the surrounds are intended for "rear side" use where they are still placed behind the listener but not at the back wall as these back speakers are.
- If you select **1CH**: The LMC-1 applies this selection for 6.1 speaker configurations where the back channel will be for a rear center speaker.
- If you select **NO**: The LMC-1 assumes there are NO back surround speakers used in your system and when discrete or matrixed 6.1 or 7.1 surround information is present the LMC-1 will simply ignore it.

- If you select **LARGE**: The LMC-1 assumes the back speakers are capable of reproducing frequencies lower than 60Hz the internal crossover is bypassed all together.
- If you select **SMALL**: The LMC-1 assumes the back speakers configured in the previous menu are capable of only reproducing frequencies higher than 60Hz.
- **DISTANCE** setting is between 0-20 feet for the back surround speakers. Choose the distance setting based on the seating position distance to the speaker.

Subwoofer

The subwoofer setting is simply a matter of choosing if you have a subwoofer present or not.

- If you select **YES**: The LMC-1 assumes you have a subwoofer connected in the speaker system and will direct all discrete Low Frequency Effects (LFE) channel information into this output.
- If you select **NO**: The LMC-1 assumes you have no subwoofer connected in the speaker system and will not process discrete LFE information. When you choose this selection, it is recommended that you have front (main) speakers capable of the LARGE setting so that they can reproduce the low frequencies present in normal program material, even without discrete LFE information.

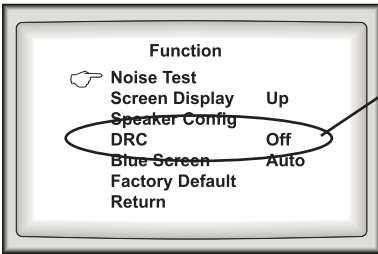

DRC

DRC (Dynamic Range Control) is feature which enables users to reduce the dynamic range of the sound so that late-night listening need not disturb others in the house, neighbors, or when listening to dynamic effects that may damage small (book shelf type) speakers while the LMC-1 speaker settings are on "LARGE".

- If you select **ON**: The LMC-1 will engage the Dynamic Range Control and this will limit the "surprise" loud passages inherent in dynamic content (in particular DVD movie sound effects)
- If you select **OFF**: The LMC-1 has no limiting on the dynamic range of the source content. At that point, the only limitations of dynamic range are the source material itself, the amplifier(s), and the speakers in your system.

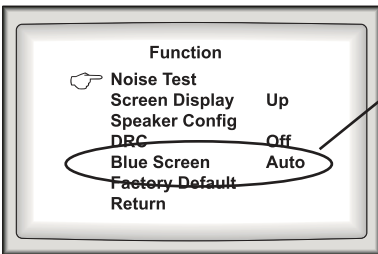

Blue Screen

The Blue Screen control is there to configure so the video image output best suits your particular components. Sometimes you may want the screen blue so the video display device always has an input signal (regardless of what source may be active or not). For example, if you are using a DLP projector and it is configured to "search" for input signals automatically, whenever a DVD or Satellite TV signal stops the projector

may begin searching other inputs. The blue screen keeps this from happening. Other times you may want to use the blue screen the least amount possible to preserve the life of the screen, such as with plasma screens. In those instances, set the blue screen to "OFF".

- If you select **AUTO**: A blue screen will be displayed when there are no video input signals.
- If you select **OFF**: No blue screen will appear.

Factory Default

If you should ever want to return your LMC-1 to “square one” and reset all of the programmable menus to the factory default settings, there are two methods by which you may accomplish this.

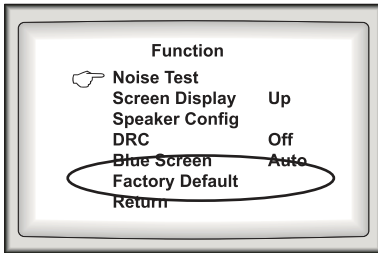

From the Remote Control (through the OSD)

Press the “**MENU**” button on the remote control to enter the main menu and select “**Function**”. Next, select “**Factory Default**”.

Next the OSD will prompt you with “**Load Factory Default?**”

If you are sure you want to reset to all of the factory default settings, press the “**OK**” button on the remote control. The factory defaults will then be reinstated.

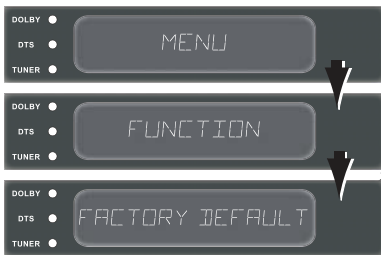

From the LMC-1 Front Panel

Press the **FUNCTION KNOB** on the LMC-1 front panel to enter the main menu and select “**Function**”. Next, select “**Factory Default**”. Next the OSD will prompt you with “**Load Factory Default?**” If you are sure you want to reset to all of the factory default settings, press the **FUNCTION KNOB** button on the LMC-1 front panel to confirm. The factory defaults will then be reinstated.

Using the AM/FM Tuner

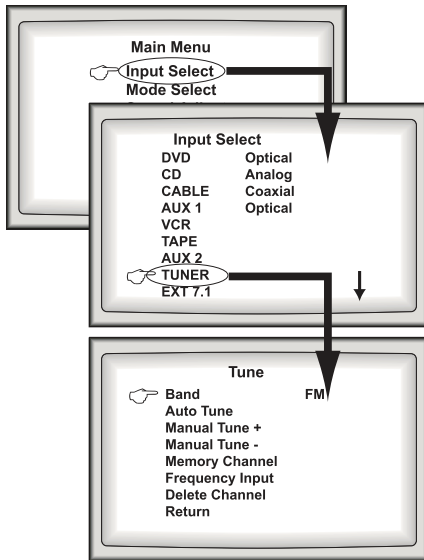

The AM/FM Tuner in the LMC-1 is a PLL synthesized electronic tuner module that has been designed to have excellent reception in residential applications when used with the supplied AM and FM antennas. Depending on where you physically locate the LMC-1, you may need to locate the antennas so that they are not in the path of interference from other electrical devices, fluorescent lighting, or other radio transmitter/receivers.

Tuning Stations

The engineers of the LMC-1 have thoughtfully given the user several ways in which to choose their AM and FM stations. This can be done directly from the front panel, from the remote or using the OSD and remote together. At any time after selecting an AM or FM station, you can view the station frequency by pressing DISPLAY on the remote control.

While most of the Tuner functions can be accessed directly with discrete buttons from the remote control, the user can access all functions through the LMC-1 front panel display (using the FUNCTION KNOB) or via OSD as shown here. Just select "TUNER" from the OSD Inputs Menu and navigate the functions with the UP/DOWN ARROW keys on the remote.

The AM frequency range is 522KHz-1611KHz (in 9KHz steps). The FM frequency range is 87.1MHz-107.9MHz (in 0.2MHz steps). Each time you manually advance a frequency, it will advance in these designated spacing increments. AM or FM can also be selected through the OSD in the Tune Screen (see diagram above).

Manually Tuning (UP/DOWN)

Manually Tuning from the LMC-1 Front Panel

If you are in the Tuner source mode, simply rotate the **FUNCTION KNOB** to the left or right to manually move the station frequency up or down.

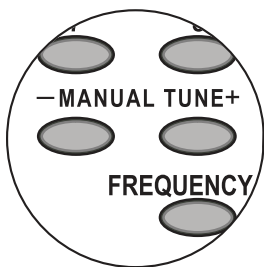

Manually Tuning from the Remote

Press "**MANUAL TUNE +** or **-**" from the bottom section of the LMC-1 remote to skip channels in manually spaced increments. If you press and hold the "**MANUAL TUNE +** or **-**" button for 1 second or more, the LMC-1 will scan the full bandwidth to find all available (tuned in) stations. When the search is complete, the unit will automatically begin to play the stations found in ascending order.

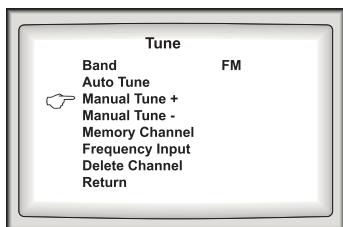

Manually Tuning via the OSD Menu

From the OSD **Input Select** menu, choose **Tuner**, then "**Manual Tune +**" or "**Manual Tune -**". This function acts just the same as manual tuning from the remote control.

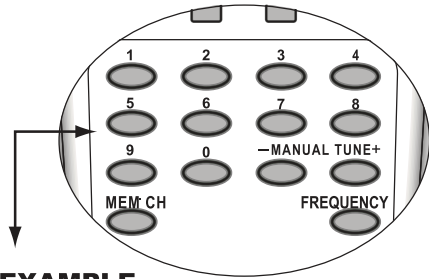

EXAMPLE

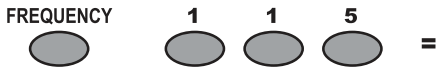

Direct Numeric Tuning

Direct Numeric Input from the Remote

From the remote, press “FREQUENCY” at the bottom right corner and then enter the station frequency numerically. LMC-1 automatically adds a “0” after you press the number “1” as the first digit so the entry will immediately show “10_” on the front panel waiting for the next numeric entry.

For example, if you wanted to input FM station 101.5, the button sequence would be:

“FREQUENCY”, then “1” (which automatically places the “0”), followed by “1” and “5”. See example at left.

Direct Numeric Input from the OSD Menu

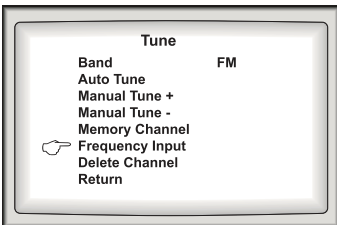

From the OSD **Input Select** menu, choose **Tuner**, then “Frequency Input”. This function acts just the same as direct frequency input from the remote control. If the first numeric entry is “1”, remember LMC-1 automatically places a “0” immediately after for the result of “10_” awaiting the next numeric input.

Automatic Tuning

Automatic Tuning from the Remote



Press the “**AUTO TUNE**” button on the remote control and the LMC-1 will search for all the broadcasting stations automatically and then populate the memory positions with each of the “tuned in” stations in ascending frequency order. The front panel display will show the frequency and the AM or FM designation as you press the “**MENU UP/DOWN**” arrow keys to scroll through the stations that were received and stored. It’s a great way to do most of the work of setting the AM/FM presets by the touch of a button, then you can go back and put in your prime choices in the first couple of positions.

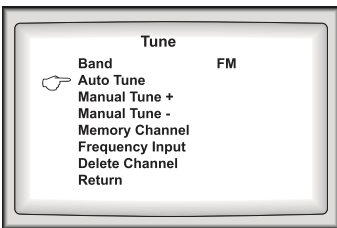

Automatic Tuning from the OSD

From the OSD **Input Select** menu, choose **Tuner**, then “Auto Tune”. This function acts just the same as engaging the AUTO TUNE mode directly from the remote control.

Selecting FM Stereo/Mono Modes



You can also select between FM Stereo or Mono modes depending upon your ability (or inability) to clearly tune in certain stations. If stations are not well received, the MONO setting may sound better because it will reduce RF interference from the weak signal. To select between STEREO and MONO settings, simply ensure you are on the FM band and use the “**STEREO**” button on the remote control (below AM/FM button) to toggle between STEREO and MONO modes.

Storing AM or FM Presets

The LMC-1 has a total of 40 station presets for the tuner. The FM channels have 30 preset locations and the AM channels have 10 locations. When numerically selecting the stations, the FM channels range from 0-29 and the AM channels range from 0-9. Many people ask why “0” is the first preset. This is because the digital processor in the LMC-1 recognizes the numeric value of 0 as the first (or lowest) number. If you find this difficult to remember, store your presets beginning with 1 and leave the 0 preset for what would normally be considered “10” on AM or “30” on FM.

Store a Preset from the Front Panel

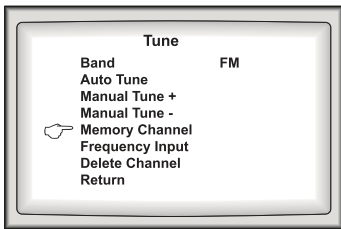

To store a station in the memory from the LMC-1 front panel, you must use the **FUNCTION KNOB** to choose the **Input Select** menu, then choose **Tuner**, then “**Memory Channel**”. Use the **FUNCTION KNOB** to scroll up or down to select the numeric position of the memory (0-29 for FM or 0-9 for AM). Once you have the number selected, push the **FUNCTION KNOB** to store that frequency as the selected preset. This can also be done through the OSD menu but you can do it directly from the remote without the OSD if you would prefer.

Store a Preset from the Remote

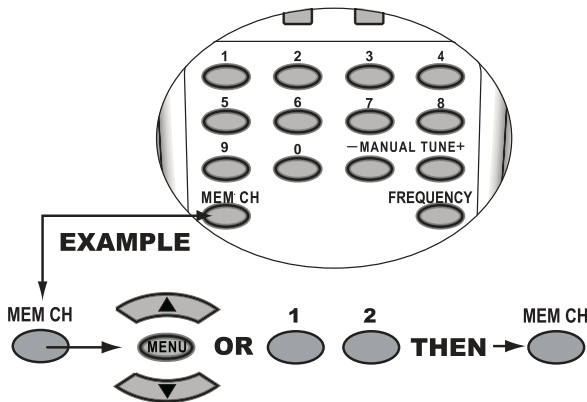

Storing presets from the remote is much easier than from the front panel because of the discrete numeric buttons on the remote.

To store a preset station from the remote, simply press “**MEM CH**” on the remote and then “**MENU UP/DOWN**” to scroll through the numeric memory positions in sequential order - or you can simply use two consecutive **numeric keys** directly to enter the memory position directly - and when you are finished press “**MEM CH**” again to save the selection in that memory position.

Deleting Preset Channels

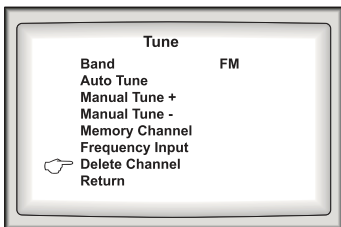

Deleting preset channels can be simply done by “saving over” an existing preset or by selecting the “**DELETE CHANNEL**” selection in the Tuner Sub Menu of the OSD. To use the **DELETE CHANNEL** function you **MUST** have the remote and OSD functions available.

When you select the delete channel option, the subsequent OSD screen will confirm “Delete Channel” and ask “Select Channel:___”. You must manually enter the numeric frequency of the channel you wish do delete by using the 0-9 numbers on the keypad. The selection will show on the OSD. If you have chosen the correct channel, press “**OK**” on the remote control to complete the operation.

Using Zone 2

The LMC-1 is fully capable of being used in (and controlled from) a second zone. The LMC-1 can function entirely as a stand alone device when used in a second zone with its built in 50W x 2 power amplifier, but you must either turn on/off the unit manually in its main room location (via front panel or through the OSD) or install an I/R repeater system to carry the remote control command to the unit. There is also an optional keypad controller and second zone remote available for the LMC-1 that takes care of all the Zone 2 needs in a complete, easy to install package.

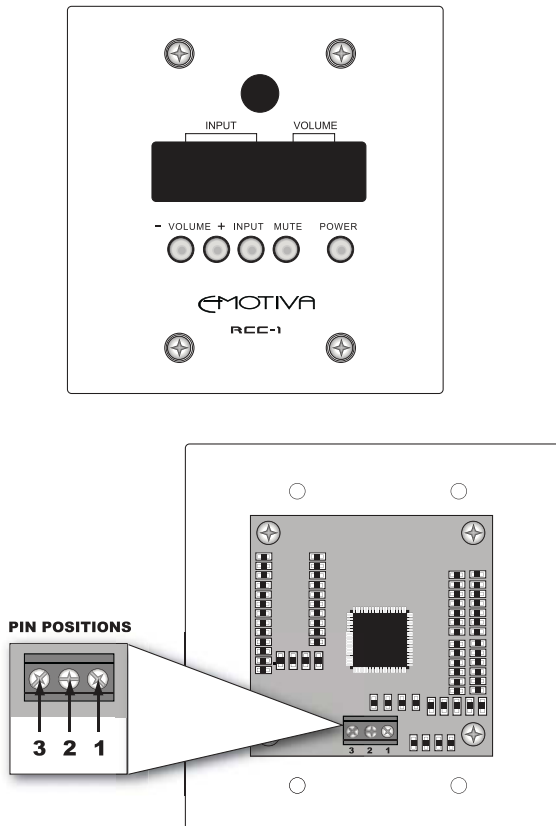

Optional Zone Control Keypad

The optional RRC-1 Zone Control Keypad solves these problems by including both tactile buttons and an I/R repeater for use with the remote control. Additionally, the RRC-1 Keypad includes a display that shows the relative volume position in the second zone and which source input is selected. The RRC-1 Zone Control Keypad is an optional accessory available from your Emotiva retailer.

Please note that **if you are using the optional RRC-1 keypad, it is not necessary to have a separate in-wall volume control** because the RRC-1 keypad will handle those volume functions. If you are not using the RRC-1 or an I/R repeater in the second zone room that enables the main or second zone LMC-1 remote to control the volume, then an impedance matching type in-wall volume control is recommended so you have control over the sound levels in that room.

RRC-1 Installation

The RRC-1 installation is a simple 3 wire installation that can be done using existing wiring provided it is not already used for speakers, telephone, internet, or other electronic devices. The 3 wires on the back of the RRC-1 keypad connect directly to the same 3-2-1 labeled terminals at the back of the LMC-1. The RRC-1 wall plate requires no connection to 110VAC power. For additional connection details, please see Page 24 for information on this procedure.

Operating Zone 2

Zone 2 Operation from the LMC-1 Front Panel



From the LMC-1 front panel **Zone Control** menu, use the **Scroll UP/DOWN** feature of the **FUNCTION KNOB** to select **"ON"** for the **Zone Power** menu item (this should be the first default position) by **"PUSHING IN"** on the **FUNCTION KNOB**. At this point Zone 2 will be active. Repeat this process to turn Zone 2 back to the OFF position.

Next use the “**Scroll UP/DOWN**” feature of the **FUNCTION KNOB** to **Input Select** for Zone 2. Any connected source input is available, but multi-channel digital source inputs are down mixed to 2 channel mode when played in Zone 2.

You can also set the volume of Zone 2 from the front panel of the LMC-1 by using the “**Scroll UP/DOWN**” feature of the **FUNCTION KNOB** to get to the **VOLUME** setting. “**PUSH IN**” and the **FUNCTION KNOB** becomes the volume control. Once you achieve the desired volume level in Zone 2, push the **FUNCTION KNOB** one more time to return to the Zone Control menu. Most people will find this much easier to do with the main remote using the OSD as described in the subsequent paragraphs.

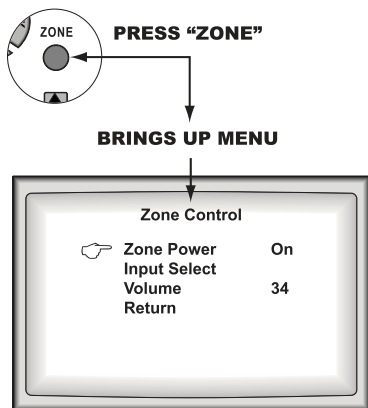

Zone 2 Operation from the LMC-1 Main Remote

To get to the **Zone Control** menu, press “**ZONE**” from the LMC-1 main remote control. The OSD will now show the **Zone Control** menu.

From the OSD **Zone Control** menu, use the “**MENU UP/DOWN**” buttons to select “**ON**” for the **Zone Power** menu item (this should be the first default position) by pressing “**ENTER**” on the remote. At this point Zone 2 will be active. Repeat this process to turn Zone 2 back to the OFF position.

If you want to select the input source or operate volume commands for Zone 2, simply use the “**MENU UP/DOWN**” buttons to navigate to the chosen menu item then select it by pressing “**OK**” on the remote.

If you choose “**Input Select**”, a Zone Input menu will appear on the OSD and you must select the input you want to assign to Zone 2. simply use the “**MENU UP/DOWN**” buttons to choose a source input (CD, DVD, CABLE, VCR, TAPE, AUX1, SYNC or TUNER) then select it by pressing “**OK**” on the remote. If you select “**SYNC**”, the Zone 2 source becomes the same input source as the one selected for the Main Zone.

If you choose “**Volume**”, the volume level will be highlighted and you will use the “**MENU UP/DOWN**” buttons to set the Zone 2 volume. When finished, select “**OK**” on the remote to exit that function.

Zone 2 Operation from the RRC-1 Wall Plate

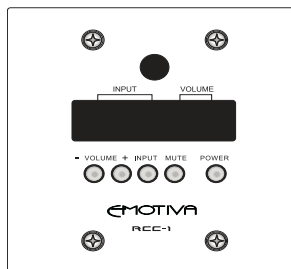

To turn Zone 2 ON from the RRC-1 wall plate, press the “**POWER**” button on the right side. Repeat this step to turn Zone 2 back OFF.

To select a source component, press “**INPUT**” to scroll through the available inputs (CD, DVD, CABLE, VCR, TAPE, AUX1, AM, or FM). If select “**SYNC**”, the Zone 2 source becomes the same input source as the one selected for the Main Zone.

To adjust volume, press “**VOLUME +**” or “**VOLUME -**” on the wall plate until you achieve the desired volume. To mute the Zone, press “**MUTE**” on the RRC-1 wall plate.

Zone 2 Operation from the LMC-1 Zone 2 Remote



For remote control operation in Zone 2, you **MUST** aim the I/R remote at the RRC-1 wall plate so it can receive the commands. To turn Zone 2 **ON** from the Zone 2 remote control, press the “**STANDBY**” button on the right side. Repeat this step to turn Zone 2 back **OFF**.

To select a source component, press any one of the available inputs (CD, DVD, CABLE, VCR, TAPE, AUX1, AM, or FM). If you press the “**SYNC**” button the Zone 2 source becomes the same input source as the one selected for the Main Zone.

If you choose “**AM**” or “**FM**” for the Tuner input, you can scroll through the preset channels on the present band by using the “**RADIO CH+**” and “**RADIO CH -**” buttons. Manual tuning or direct frequency input can only be operated at the front panel of the LMC-1.

To adjust volume, press “**VOLUME +**” or “**VOLUME -**” on the remote until you achieve the desired volume. To mute the Zone, press “**MUTE**” on the remote.

Zone 2 Preamp Outputs with External Amplification

If you choose to have a power output greater than that of the internal Zone 2 amplifier contained within the LMC-1, you can use the analog RCA audio outputs at the back of the unit labeled **ZONE**. See page 23 for connection information on this procedure.

Please note that whenever Zone 2 is set to “**ON**” in the OSD menus or it is being used from the optional RRC-1 Keypad, the circuitry inside the LMC-1 will be “awake” even though the front panel lighting and display of the LMC-1 are not. This will cause the **Control Output** (3.5mm jack) for external amplifiers to stay (or remain) active in the event there is an external Zone 2 amplifier as described in this section. This is normal operation and will not harm the Main Zone amplifiers whatsoever because the audio outputs to the Main Zone amplifiers are switched off when only Zone 2 is operating.

Using the +12 VDC Control Output to Turn On Other Devices

The Control Output is current limited to 120mA, so it may not be adequate to turn on more than 1 multi-channel amplifier. If you prefer that additional amplifiers or additional gear (lighting control, projector power, etc.) be controlled with the LMC-1 Control Output, please contact your Emotiva dealer for custom installation options. In many cases, the device control you desire can be integrated with a single command sequence through macro programming on a custom remote control setup.

Speaker Placement Tips

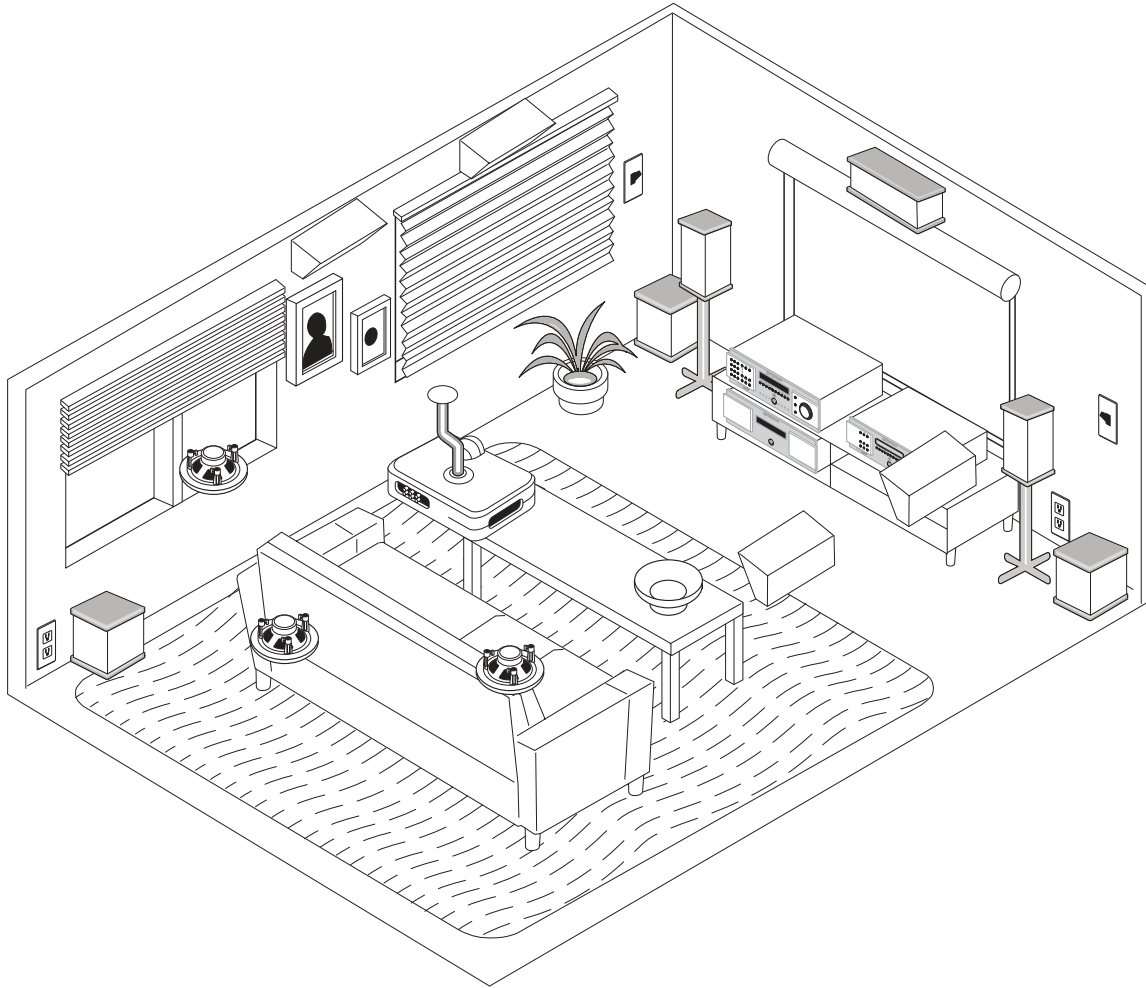

Tips Before Beginning

Read this section thoroughly. There are a number of ways in which it may seem aesthetically pleasing to place speakers in a room that will ultimately result in a sound quality compromise. The placement of speakers is equally as important as the room itself. While there may be very little you can do about the room where your home theater is installed, you can choose placement of speakers within that room to maximize the sound quality of the system. Ultimately, this will give a much better result when you are enjoying your home theater and your new Emotiva LMC-1.

Overall, the best placement for front speakers is where the sound is directed at ear level. This means that the speakers themselves can be in positions lower (like small floor standing speakers) or higher (like in-wall or in-ceiling speakers) as long as the sound is “pointed” toward the listeners and preferably around ear level. This is not necessarily the case with the rear speakers or the side axis speakers. Read each of the sections carefully for the most appropriate positioning. A subwoofer is also a little challenging to install depending on the room. In multiple subwoofer installations, the positioning of the woofers to the listener as well as to each other is critical because there can be problems with cancellation if optimum placement is not observed.

The Front Speakers

You should closely follow the placement recommendations of your speaker manufacturer, with the addition of the following points:

- *The left and right front speakers should be positioned so that your TV is exactly centered between them. This will help focus your attention towards the screen.*
- *For the best overall imaging, the left speaker should be set exactly the same distance and angle away from your listening position as the right speaker. It is recommended that you use a tape measure to set them up to be the same distance away, within about half an inch tolerance.*

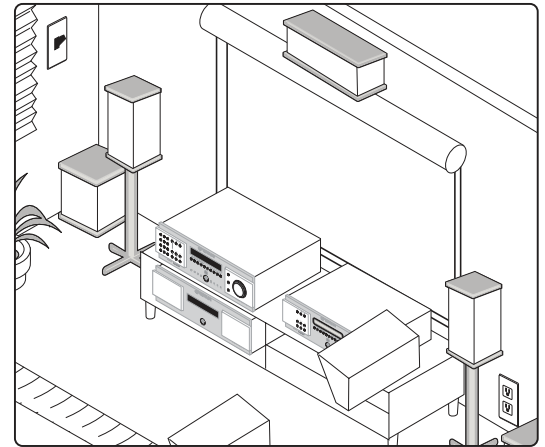

Place LEFT, CENTER, and RIGHT main speakers at equal distances from the listening position.

If you have a smaller TV, the speakers should be no more than two feet away from the sides of the TV. If possible, have the center, left and right speakers at the same height (within two feet). This will help give a smooth transition when sound effects move from speaker to speaker.

Ideally, the speakers should be no closer than two feet from the rear and side walls, in order to reduce any reflections that might upset the imaging. If your speakers are closer than this, you can experiment by adding sound deadening material such as drapes on the walls to reduce any unwanted reflections.

The Center Speaker

Most movie dialog will come from the center speaker, so careful positioning is an important part of a good home theater system. Your eyes and ears should focus your attention towards the center of the screen.

The center speaker can sit on top, or directly underneath the TV, as long as it is located on the center line and not off to one side. Ideally you would try to maintain a deviation from the center line of the speakers of less than 24". This means the center speaker will not be lower or higher than 24" to the center measurement of the LEFT and RIGHT MAIN speaker center measurements.

Position the front face of the speaker close to the front edge of the TV cabinet. (The sound waves may otherwise reflect off the top of the TV cabinet and distort the center imaging).

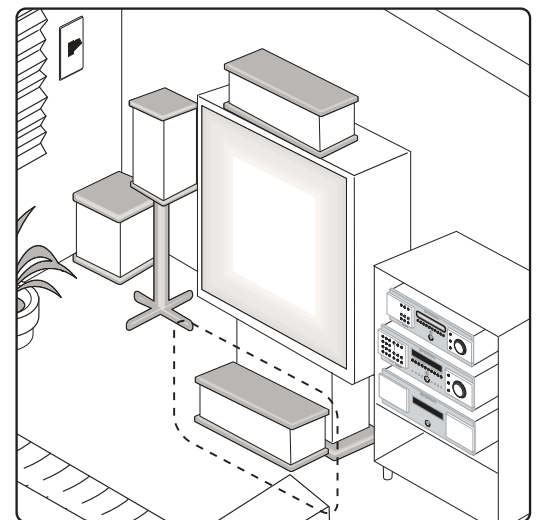

Whenever possible, place the center speaker no more than 12" (25.4cm) above or below the front speakers

In some systems, two center speakers are used; one on either side of the TV. As they are in mono, the result is a sound image that is positioned exactly at the screen center.

The Surround Speakers

Place each surround speaker to be an equal distance away from your central listening position and keep them at least one or two feet above ear level.

The diagram to the left shows the use of dipole surround speakers. These are usually positioned to the side of your listening position. They radiate forwards and backwards and have a quiet null zone (the “apex” of the triangular shape) which should point towards the listener. The overall effect is that you cannot hear the direct sound from the surround speakers because they don't directly radiate into the listening space. Most manufacturers of dipole speakers intended for use as an effects or surround speaker have excellent details on optimum positioning for the best overall results based on the application.

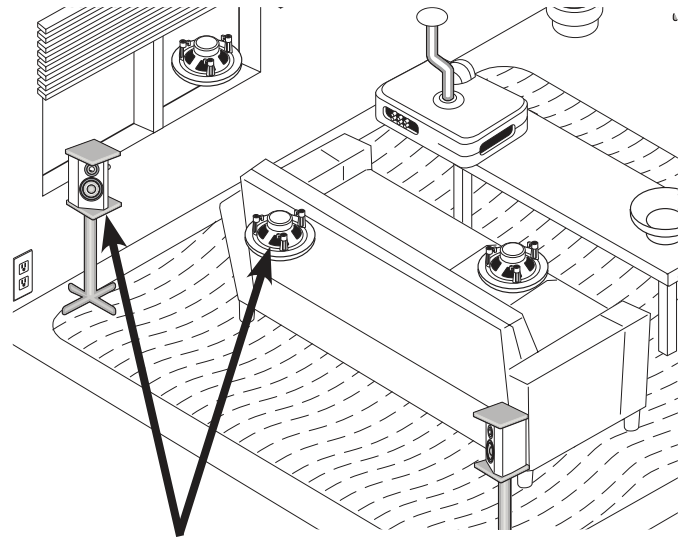

*Dipole Surround Speaker Locations OR
In-Ceiling Speaker Locations*

Conventional surround speakers can be placed behind the listener, on the rear walls or the side walls or in the ceiling (as the diagram indicates). Adjust the angle so they do not point directly at the listener but cause reflections from the sidewalls, floor, or the ceiling. Avoiding direct aim at the listening positions will give the effect of broadening the rear soundstage so that you cannot distinguish the sound as coming from a small box on the wall but from a larger area behind you.

Surround Back Speakers

The LMC-1 has two extra outputs for surround back speakers. These create a wonderful sense of realism in surround effects during playback of Dolby Digital EX, Dolby Pro Logic IIx, and DTS ES.

The LMC-1 can be configured for one or two surround back speakers in the **Speaker Config** menu. Ideally, all the surround speakers should be of the same make and model, and fitted at similar heights to produce a smooth continuous sound field. If you are connecting one surround back speaker, connect its amplifier input to the LMC-1 **LEFT CHANNEL BACK SURROUND (LBS)** output. Place the speaker behind your listening position.

Subwoofer Location

A subwoofer typically sounds best in a corner with at least 5 feet of wall to either side. Due to the short wavelengths of high-frequency sounds, they don't interact strongly with the size and shape of a room. Lower frequencies long wavelengths that can cause "Standing wave" problems. Placing the subwoofer in a corner usually creates the best possible situation for the sound to interact with the room, allowing even distribution of the bass frequencies. Often the corner that offers nearby placement to the front speakers may yield the best results, but you should try several locations before settling on just one.

The best location for a single subwoofer can be found by playing a couple of different low frequency test tones (or some music with heavy sustained bass passages) and proceeding with the following easy 1-2-3 process:

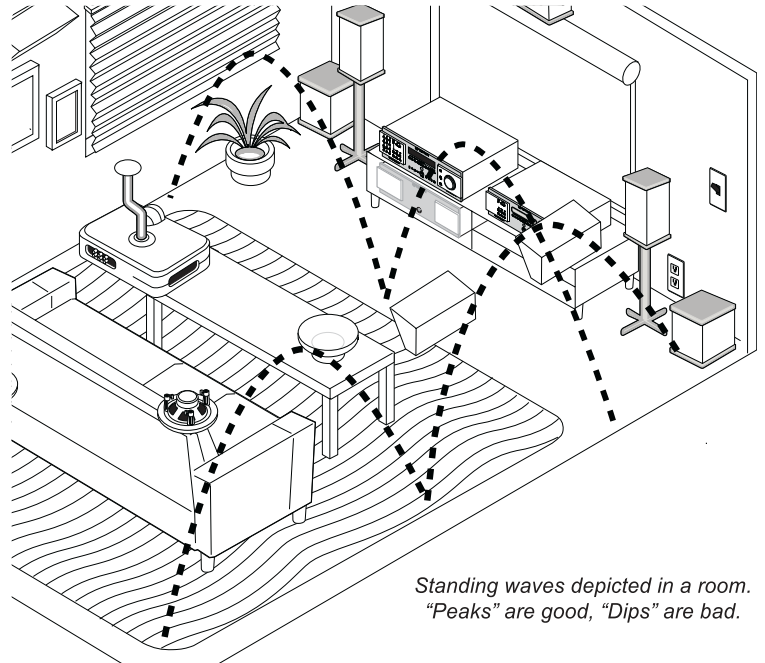

Standing waves depicted in a room.
"Peaks" are good, "Dips" are bad.

1. Place the subwoofer right on the seat of your couch or listening chair.
2. You can then either run the calibration (noise) signal through it, or simply plug the analog outputs of a CD player directly into your subwoofer's low-level inputs. Turn down the subwoofer's volume level before turning on the CD, then play the test tones or some music with heavy sustained bass passages.
3. Walk around the room, standing in all the positions where you might be able to place the subwoofer. Again, this is usually near the corners of the room. Try locations fairly close to the front speakers.

Notice where in the room the bass output from the subwoofer sounds the loudest. Shut things down and install the subwoofer there. This is the best position for the subwoofer. The bass will sound the best when you are sitting in your normal listening position.

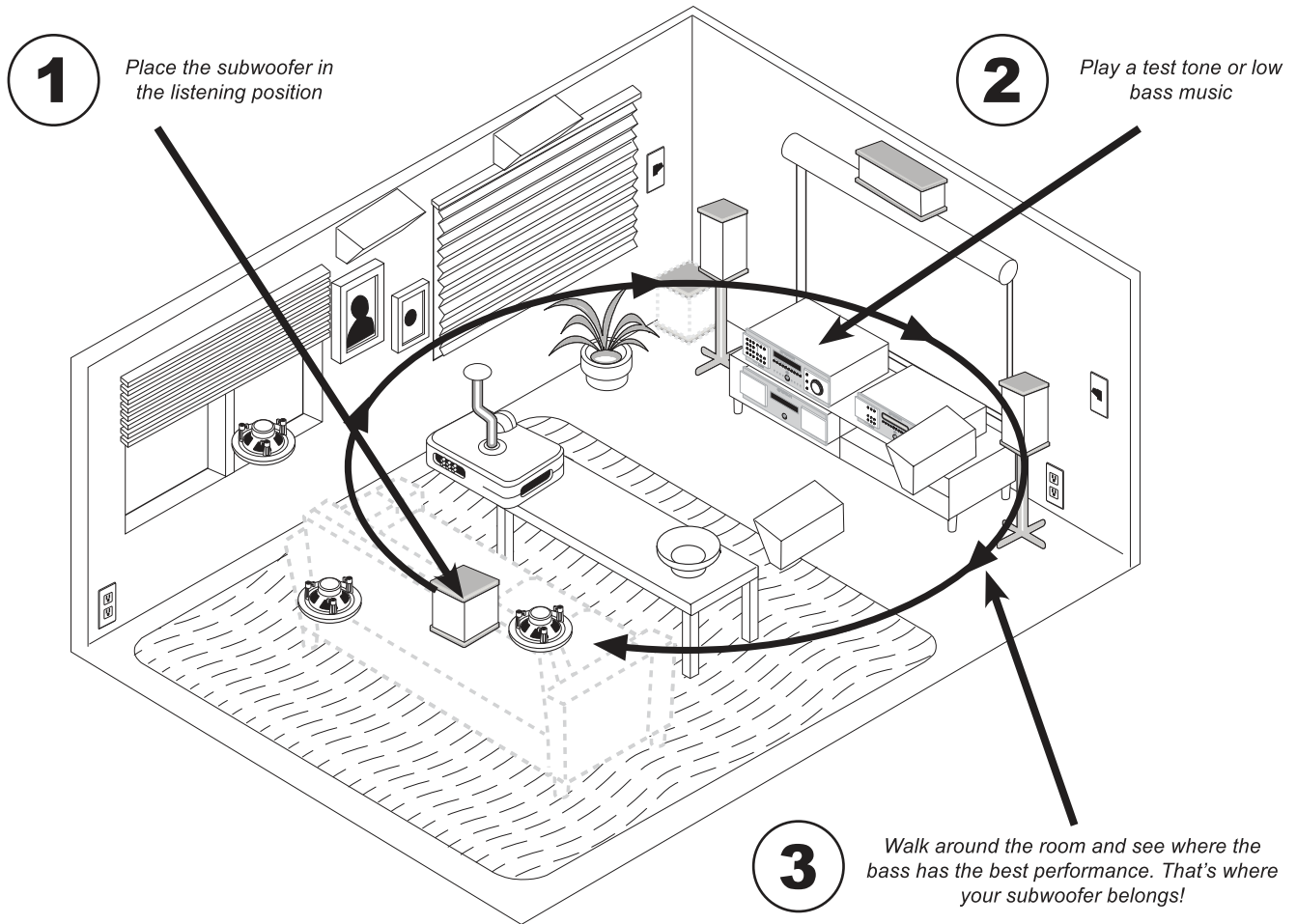

If your subwoofer seems to sound best when it is near the front speakers (often the case), keep in mind that most television sets may not react well to the subwoofer if it is not built specifically for use in a home theater application. While most front Left/Center/Right speakers do have shielding when intended for use in a home theater application, subwoofers are not always magnetically shielded and may damage the television if placed too close. If you want to check if this will be a problem, select an unused video input on the television to bring up a single color screen. If you see any color distortion anywhere on the screen, an unshielded speaker is too close to the screen and should be moved away from the television until the color distortion disappears.

Note - most powered home subwoofers feature a phase control with a range between 0-180 degrees. This is present so that in situations where the optimum location is not particularly desirable, you can locate the subwoofer elsewhere nearby and make a slight adjustment to the phase so that is sound arrives to the listener at the same time as the other speakers. Ideally, sound arriving at the same time is what allows the subwoofer to create the illusion of the main speakers making the bass. This is what enhances the listening experience.

Troubleshooting Guide

The Emotiva LMC-1 is expertly designed and built to provide years of trouble-free performance. Most problems that occur can usually be solved by checking your setup or making sure that the audio and video components connected to the LMC-1 are on and fully operational. The following information will help you deal with common setup problems you may experience during normal use of your unit. If problems persist, contact your Emotiva Dealer for help.

No Sound (from one or more full range speakers)

- *Speaker cables may have come undone. Turn off your system and check the cables, and tighten the binding posts.*
- *An audio cable may have an internal break. Switch cable with a different channel to see if the problem migrates to a different channel or stays in the affected channel(s).*
- *The correct input is not currently selected.*
- *The volume level is low for the channels concerned. Re-check the calibration procedure (See pages 33-34).*
- *The mute switch is on.*
- *The channel has not been turned on in the Speaker Configuration Menu (See pages 35-37).*

No Subwoofer (or poor output)

- *The powered subwoofer's amplifier is off or its input level controls are set low.*
- *Are all other speakers set to LARGE in the Speaker Size menus? If so this may redirect some of the bass energy to the main speakers (See note on page 35 for "MAIN" speakers)*
- *SUB is not switched on in the Speaker Configuration Menu (See page 37).*
- *Recheck the calibration procedure (See pages 33-34).*
- *Adjust the crossover on the subwoofer*
- *Adjust or check the bass management feature of the DVD player (especially with DVD-A)*
- *Adjust the physical location of your subwoofer. See pages 45-49 to find the best location for your subwoofer.*
- *If the bass is weak during Dolby Digital or DTS playback, check the correct audio output is selected in the "setup" menu of the DVD you are watching, otherwise it may just play stereo into your LMC-1 and you won't get the true LFE signal to the subwoofer.*

Poor AM Reception

- *Often one of the main complaints about poor AM reception is that the same AM station can be heard at different frequencies. Check to see if BOTH wires of the AM loop antenna are connected. A loop antenna is required for AM reception, as it forms part of the front-end tuned circuit.*

Poor FM Reception

- *The antenna may be incorrectly attached.*
- *Station not correctly tuned in, weak or off the air.*
- *FM reception can be improved by using external antennas. Some cable TV feeds also offer FM reception.*

Input Selection Problems

- *If you find that certain inputs do not produce results when selected, Check the INPUT SELECT menu of the OSD (page 28), and make sure that the input has been configured correctly for the connection type you are using (for example you may have incorrectly selected the DVD to be on “coaxial” when it should be on “optical” because of the cable you have used).*

There is No TV Picture

- *Make sure that the video input of your TV monitor is connected to the monitor output on the LMC-1 rear panel labeled “OUT” (whether it’s Component, S-Video, or Composite).*
- *Check that your monitor is selecting the correct video input. Sometimes it is defaulted to “TV” or “Cable” when you should have it switched to an AUX or A/V input.*
- *Check the video connection from your selected source component into the LMC-1.*
- *Make sure that you are using the correct video connections. If in doubt, try connecting the video output from your source directly to your TV monitor. This will help you narrow down the problem.*
- *Use only one type of Component Video, S-Video, or Composite Video connection on a given input. If more than one input is present at the same time, the LMC-1 will choose higher quality format and the S-Video and the Composite Video output will be off in this case.*
- *For the EXT 7.1 audio input, there is no dedicated video input but it will display video for any material on the AUX 1 video input. If you are using the 7.1 output and you want to have a video feed, use the AUX 1 video input and be sure to configure it correctly in the Inputs Menu.*

No Tone Control Functions

- *Remember that the tone controls are non-functioning whenever the LMC-1 is using the 7.1-CH input, whenever it is in “BYPASS” mode, or in Zone 2.*

No Dolby Digital or DTS Playback

- *Look for the Dolby Digital or DTS Logo on the source program’s box or sleeve. Make sure your player’s digital output is set to BITSTREAM for Dolby Digital or DTS. This is often a in DVD player’s setup menu for the unit itself, not the disc’s menu.*
- *Some discs are available with a number of different options, such as Dolby Digital or Dolby Pro Logic. Make sure that you have selected the correct mode from your player’s menu. Only digital inputs will work for these modes. Check that your player’s digital output is connected to the appropriate corresponding digital input on your LMC-1 and that the input is configured to recognize the correct connection type.*
- *There is no AC-3 RF input connection for Laserdisc players. You will need an external RF demodulator.*
- *Check the calibration procedure from time to time. This is an excellent way of checking that all speakers are working correctly.*
- *Noise bursts are heard when DTS encoded CDs or LDs are played. Compressed DTS data uses the normal digital audio tracks of CDs and LDs. This analog noise may be heard in your system before the DTS digital signal is locked on, or it may appear as a background hiss. To reduce or prevent this noise, disconnect any analog connections to your CD, DVD, or Laserdisc players. Just use the Digital connections and see if this addresses the problem.*

No On Screen Display

- *Press the remote's MENU button to activate the OSD. It should be present even when no video source has been selected. If you do not have any on screen display, make sure there is at least a TV picture from one or more of the sources controlled through the LMC-1. If the problem is not in the cabling for the entire picture (both source material and OSD), please call Emotiva or your Emotiva Dealer for assistance.*

Blue Screen and No Picture During On Screen Display

- *On Composite Video and S-Video connections into the TV, the OSD overlay will show over the top of the picture. If you have used the highest quality Component Video connections into the TV, the picture is switched off (sound still remains) for the duration the OSD is on screen. There is a blue background during this time. This is normal operation and is intended to minimize any interference in the video signal path.*

Sound drops out with CD or DVD playback

- *Make sure the disc is not dirty or scratched.*
- *Some inexpensive players and changers tend to mistrack more often, causing dropouts with an external DAC.*

Remote Not Working

- *Make sure the batteries are not dead or installed incorrectly.*
- *Make sure that the LMC-1 front panel receiver window is not obstructed.*
- *If you have programmed the LMC-1 commands into a "learning" type remote, check the user's manual for that particular device for tips on how to correctly program and/or test the remote commands.*

ZONE 2 Not Working

- *To access Zone 2, you must use the OSD Zone 2 menu (as shown on page 42-44) to turn it on and select source inputs when you are ready to use it.*
- *If you are getting no sound, check that the powered Zone 2 outputs are connected directly to speakers OR that the ZONE preamp level is connected to a functioning amplifier/speaker combination for the room.*
- *Zone 2 can also be powered on and off from the optional RRC-1 wall plate or Zone 2 remote. If you have these accessories and are having problems turning on from either, check that the wall plate connectors match color in pin positions 1, 2, and 3 with the wiring on the back of the LMC-1 unit. Also check that the batteries are installed correctly in the Zone 2 remote.*

Zone 2 does not play digital inputs!

- *Zone 2 can play analog sources independent of what is playing in the Main Zone. It cannot play from a digital-only source unless that input is selected and playing in the Main Zone and when it does that using the "SYNC" command, it will play a digital 2 channel down mix of the source material. To play a source such as a DVD player in Zone 2 independent of the Main Zone, make sure you connect the player's L/R analog audio output to the LMC-1 in addition to the "Coaxial" or "Optical" connection.*

External Amplifier(s) Shut Down (Often or Prematurely)

Check the following:

- *Make sure each speaker's average impedance is not less than your amplifiers can safely handle.*
- *The amplifier(s) have good ventilation, no vents are covered.*
- *Try setting all the speakers to Small, and let your subwoofers handle the heavy bass.*
- *Check that the amplifier(s) power output is a good match for your speakers. If your speakers are inefficient, consider using larger power amplifiers.*
- *Make sure all wiring is correct and there are no shorts. If wires have been run under carpet, under base boards (or along tack strips) there is a possibility they can easily be shorted by sharp edges or something that punctures the insulation. Also, if your wiring is in the walls - make sure that there was not an accidental "staple" puncture from securing wiring to framing studs or wall/floor joists. This evaluation is easily done with an Ohm meter.*

External Amplifier(s) Do Not Turn Off with LMC-1

Check the following:

- *Make sure the 3.5mm plug is connected between LMC-1 and the amplifier(s) AND*
- *Make sure Zone 2 is set to "OFF", otherwise it is normal for the output to remain on as long as Zone 2 is set to "ON".*

LMC-1 "Locks Up" (No Response)

- *The LMC-1 is a microprocessor controlled device of great complexity. Occasional power fluctuations and spikes may cause the LMC-1 to "lock up" or act strangely.*
- *Unplug AC power momentarily, and press "POWER" to turn back on. If this does not work, try the reset procedure.*

Reset Procedure

The LMC-1 can be reset from the front panel as follows:

- *Press the FUNCTION knob on the left and select the FUNCTION menu. Scroll UP/DOWN until you reach the FACTORY DEFAULT selection and press the FUNCTION knob. The screen will ask you "Load Factory Default". Press the FUNCTION knob once again to load the reset command.*
- *When the LMC-1 has been reset, it will shut off. Turn the LMC-1 back on and it will go to the default screen. It has now been reset. If the LMC-1 has to be reset regularly, you should invest in a good quality AC line conditioner or contact Emotiva for technical support.*

"Hum" Noises

- *This problem is more than likely caused by a "ground loop" in your system, rather than a fault in the LMC-1. Follow these steps to isolate the main cause of the hum, there may even be more than one. Remember to turn off all components in your system, including the LMC-1, before disconnecting or connecting any cables.*

Disconnect the following items in order, and check each time if the hum has gone away:

- *Disconnect all cables which come from outside the room, such as cable TV, satellite TV, or roof top*

antennas. Make sure that they are disconnected where they first enter the room, so they are making no connection to the LMC-1 or the TV, or any other component. If the hum is caused by the cable TV line, then you will need a "ground loop isolator." This is an inexpensive device fitted in line with the coaxial cable feed. Contact your cable company or your Emotiva Dealer (unless purchased through AV123) for assistance.

- Disconnect all connections from the LMC-1 to your TV.
- Disconnect any component which has a grounded power cord.
- If the hum persists, disconnect all the source components one at a time from the back of the LMC-1, until you identify the problem. (Ground loop isolators are available for audio lines and video. Ask your Emotiva Dealer for assistance)
- Try moving the speaker cables away from any power cords. Try just one speaker, connecting it to different channels and see if an amplifier channel is bad.
- If you are still having a problem, remember that Emotiva's dealers and technical support staff will assist you.

Other Probable Causes of Noise

- Speaker noise may also be caused by interference or noise on your AC line. Make sure there are no large appliances sharing the line, or halogen lamps or light-dimming Triac devices.
- Try connecting your system to another AC socket on a separate line.
- If the hum is heard from within the LMC-1 and not through the speakers, this may also be caused by interference on the AC or DC lines. The power transformers may turn this interference into an audible noise. Internal hum can be made worse by a shelf or cabinet resonating, so try moving the LMC-1 to another shelf.
- Try moving your components further away from the TV, especially if you ever notice the screen has changed color in the area closest to the component.
- If you have very high efficiency speakers, these may tend to reveal noises which other speakers do not.

Problems with the whole A/V System

If you are having more complex problems in your overall home entertainment system (not just with the LMC-1 preamplifier/processor), please contact your Emotiva Dealer or AV123 (Exclusive US Distributor) for professional installation assistance.

These professionals have years of experience with a wide range of home entertainment and lifestyle products and can offer you assistance in troubleshooting and rectifying problems.

AV123 (Contact Information)

Toll Free -	(877) 543-7500 (menu option 2)
Website -	www.av123.com (click on "support")
e-mail -	support@av123.com

LMC-1 Technical Specifications

Preamp Audio Section

Input Sensitivity Line In:	125mV for 0.5V output from source unit
Input Impedance Line In:	47K Ohm +/-5%
Signal-to-Noise Ratio (rel 2V out):	Analog = 97dB, Digital = 105dB
Distortion:	<0.1% 20Hz-20kHz with 80kHz measurement bandwidth
Frequency Response (+/-0.5dB):	20Hz- 20 KHz / 0dB ref
Line Out Freq. Response (-3dB):	20Hz- 20 KHz / 0dB ref (except LFE, which is 20-160Hz)
Channel Separation @ 1kHz:	>70dB
Tone Control:	Bass = +/- 10dB, Treble = +/- 10dB

Zone 2 Power Amplifier

Rated Power Output (Zone 2):	2 x 25 Watts (Stereo) into 4Ω Load
Total Harmonic Distortion (THD):	<0.1% 20Hz-20kHz with 80kHz measurement bandwidth
Signal-to-Noise Ratio:	>100dB, Unweighted (Full Output Reference)
Frequency Response:	(-3dB) 20Hz +/-5Hz - 20 KHz +/-50Hz 1KHz/0dB ref

Video Section

Video Input/Output:	1V p-to-p, 75 Ohm
Bandwidth:	Component = 100MHz, -1.5dB
<i>(Video upconversion is fully automatic circuitry)</i>	S-Video = 6MHz, -2dB
	Composite = 18MHz, -1.5dB

Tuner Section

Range:	FM = 87.5-108MHz in 0.2Mhz steps / AM = 530-1710kHz in 10kHz steps
Usable Sensitivity:	FM = 1.6μV @ 75 Ohms / 15.2 dBf @ 75KHz (30dB DEV) Mono AM (S/N 30% Modulated) = 16μV @ 20dB S/N (600μV/m) / 48dB @ 1mV input
Audio Ouput Bandwidth:	FM = 30Hz-15kHz (+0.5. -3dB)
50dB Quieting Sensitivity (FM):	31.6μV @ 75 Ohms, 41.2dBf in Stereo

Other Details

Trigger Outputs	12 VDC, 3.5mm jack, Center Pin is Positive / Current Load <120mA
Electrical Power Requirement:	115VAC, 60Hz or 230VAC, 50Hz
Raw Weight:	20.5lbs / 9.3 kg
Shipping Weight:	27bs / 12.25 kg
Dimensions:	19.8" W x 6.5" H x 15.7" D 504mm W x 165mm H x 398mm D

Licensing and Trademark Disclosures

DTS Disclosure

This product is manufactured under license from Digital Theater Systems, Inc. US Patent No 5,451,942, 5,956,674, 5,974,380, 5,978,762 and other worldwide patents issued and pending. "DTS", "DTS-ES Extend Surround", and "Neo:6" are trademarks of Digital Theater Systems, Inc. Copyright 1996-2005 Digital Theater Systems, Inc. All Rights Reserved.

Dolby Disclosure

This product is manufactured under license from Dolby Laboratories. "Dolby", "Pro Logic" and the double-D symbol are trademarks of Dolby Laboratories.

Apple Disclosure

"iPod" and "FireWire" are trademarks of Apple Computer, Inc.

Sirius Satellite Radio Disclosure

"Sirius" and "Sirius Satellite Radio" are trademarks of Sirius Satellite Radio, Inc.

XM Satellite Radio Disclosure

"XM" and "XM Satellite Radio" are trademarks of XM Satellite Radio Holdings, Inc.

Emotiva Disclosure

© Copyright 2006 Emotiva

All Rights Reserved. Emotiva reserves the right to make improvements to its products at any time. Therefore, the specifications of the product and the specific details of this manual are subject to change at any time.

Limited Warranty

The Emotiva LMC-1 has been created to perform flawlessly for many years. As a result of this quality and craftsmanship, Emotiva offers the following warranty to owners of the LMC-1.

Emotiva Audio warrants the LMC-1 to be free from defects in materials and workmanship for a period of **five years** from the original date of purchase. The following items are excluded from, or will void this warranty coverage:

- 1) *Damage to the LMC-1 caused during shipment and handling.*
- 2) *Damage to the LMC-1 caused by accident, misuse or abusive operation contrary to the instructions specified within this manual.*
- 3) *LMC-1 units that have had the serial numbers defaced, modified, or removed.*
- 4) *Damage to the LMC-1 resulting from a modification of, or attempted repair by any person or company not authorized by Emotiva.*
- 5) *Any LMC-1 unit purchased from a non-authorized dealer.*
- 6) *Emotiva does not assume liability for loss of use, or damage to, associated or connected equipment.*

Service Assistance for the LMC-1

Please note that BEFORE sending your LMC-1 in for repair, you MUST call Emotiva and obtain a return authorization (R/A) number. Before contacting Emotiva to begin the R/A process, please have as detailed a description of the problem(s) you are experiencing and the conditions under which the problem(s) occur. Additionally, please be sure to check the troubleshooting guide in this manual to rule out the possibility of something simple you may have overlooked. If you purchased your unit from AV123, please contact them for an R/A number. Please remember, this is a complicated product and most instances of perceived product failure are the result of improper set up or operation. Emotiva and its dealers will help you ascertain whether you have an operational problem or product defect.

Once you have obtained the R/A number, you must print this clearly on the outside of the box so it will be possible to determine from whom the LMC-1 came once it arrives. Parcels arriving without an R/A number will be refused and returned freight collect.

If you purchased your unit from AV123, please contact them for an R/A number:

AV123 (Contact Information)

Toll Free - (877) 543-7500 (menu option 2)
 Website - www.av123.com
 e-mail - support@av123.com

If you purchased your unit directly from Emotiva or from an authorized Emotiva Dealer, please send your repairs with R/A number to:

Emotiva

Attn.: Repair Department
 106 Mission Court, Suite 101
 Franklin, TN. 37067
 Reference - (Put your R/A number in this spot)

EMOTIVA

Emotiva

106 Mission Court, Suite 101
Franklin, TN. 37067

Toll Free - (877) EMO-TECH
Website - www.emotivaaudio.com

Distributed Exclusively in the US by:

AV123

2150 W. 6th Ave, Suite L
Broomfield, CO 80020

Toll Free - (877) 543-7500
Website - www.av123.com
e-mail - info@av123.com