

Modification Manual
Audio Research Corporation
ST-70-C3 Super Modification Kit
for the
Dynaco Stereo 70
Power Amplifier

PRICE \$4.00

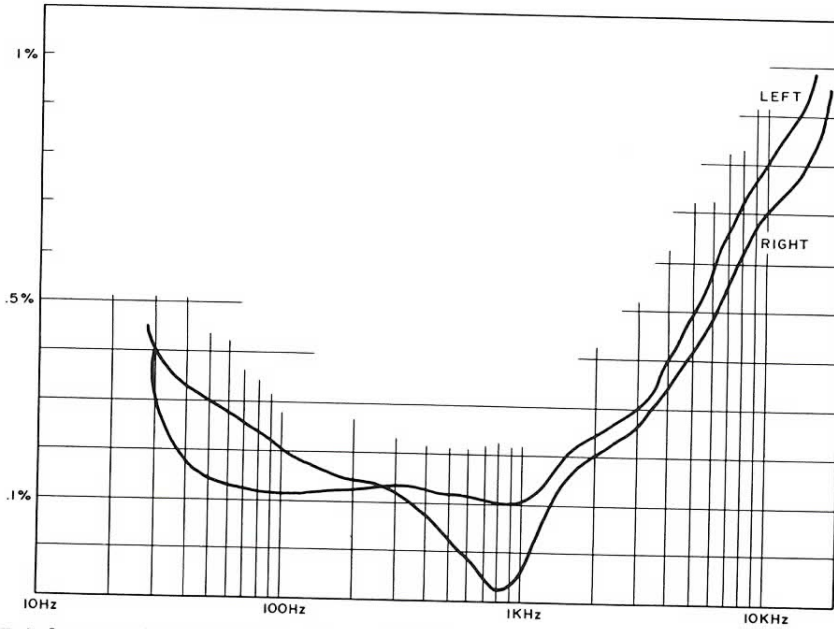

Total Harmonic distortion in a modified ST-70-C3, both channels driven.

NOISE

LEFT CHANNEL

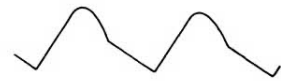

10mV P to P
120 Hz

RIGHT CHANNEL



5mV P to P
120 Hz

Noise patterns in the two channels. Input sensitivity is $\approx 830\text{mV}$ for $22\text{V RMS}/16\Omega$

POWER BANDWIDTH

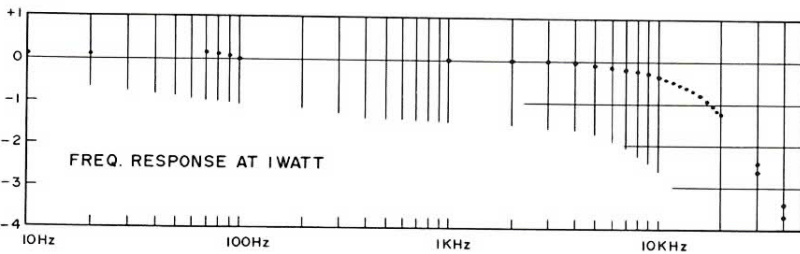
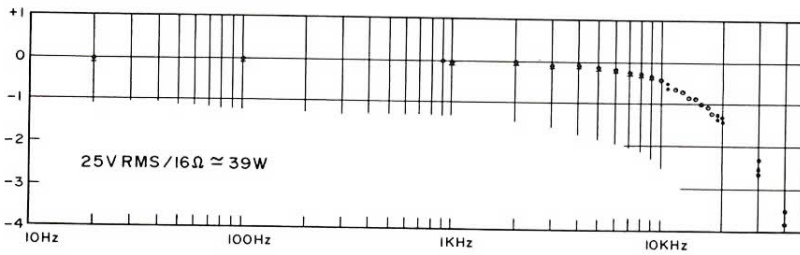

VOLTAGE CHART

Tube Pin	Any 6L6GT	V1	Either V2/V3	Either V4/V5	V6/V7
1		+175VDC	+90VDC	+410VDC	+270VDC
2	*6.3VAC			+90VDC	+100VDC
3	+420VDC			+105VDC	+110VDC
4	+420VDC	10VDC	*6.3VAC	*6.3VAC	*6.3VAC
5	-42VDC	10VDC			
6		175VDC	90VDC	+260VDC	+410VDC
7	*6.3VAC			+100VDC	+90VDC
8				+110VDC	+105VDC
9					

These are approximate voltages taken at 118VAC line level and may vary $\pm 20\%$ from unit to unit.

*Approximately $\pm 50\text{VDC}$ bias is also present at these pins.

TABLE IV	
Performance Specifications	
Power: 16Ω : 30W per channel (Both channels operating)	
THD < .1% @ 1kHz.	
< .5% @ 30Hz	
< 1.0% @ 15kHz	

Audio Research Remakes Dynaco's Stereo 70

by Edward T. Dell, Jr.

THE IMPULSE to make the good better, runs deep in the craftsman. The simplicity and elegance of the Dyna circuitry in the Mark III and the more modest Stereo 70 exerts a strong pull on the mind of anyone who regards an amplifier circuit with the same sort of pleasure rising in him that accompanies the first taste of a good wine.

That impulse lay behind the editor's project of a craftsman's version of the Stereo 70 back in 1966. (*Stereophile*, No. 4, 1976, reprint available for \$1.50 from TAA). The Dyna amplifier circuit was left virtually unchanged with only an AC balance and a metering circuit added, but military grade components were used throughout. The power supply was doubled, and modified to provide more filtering and much more capacitance.

What moved William Z. Johnson of Audio Research Corporation to undertake modification of Dyna's Stereo 70 only he knows. I would guess it grew out of Johnson's habit of making the good product even better. The result is a lower powered cousin of The Audio Research D-76-A whose amplifier configuration is shifted from the spare economic simplicity of Dyna's three tube circuit (Fig.1) to the balanced completely push-pull elegance of the D76A (Fig.2). The result of the changes are evident in Fig.3. The modified ST-70 is a lower powered unit, of course: 30 Watts versus 75 Watts per channel in the D76A.

In amplifier configuration, the ST-70-C3 lacks only the constant current source stage of the D76A. The other differences are size of output, tubes and transformer, and a much larger, partially regulated power supply. The modified unit has a zener regulated supply for its input tube and a D.C. filament supply for it as well. The power supply uses the Dyna transformer, fuse, line cord, and power switch, but adds silicon diode rectifiers and 330 μ F total filtering of the high voltages. The experimental prototype used a thermistor in the ac line but proved to have little usefulness.

But, strictly speaking, the ST-

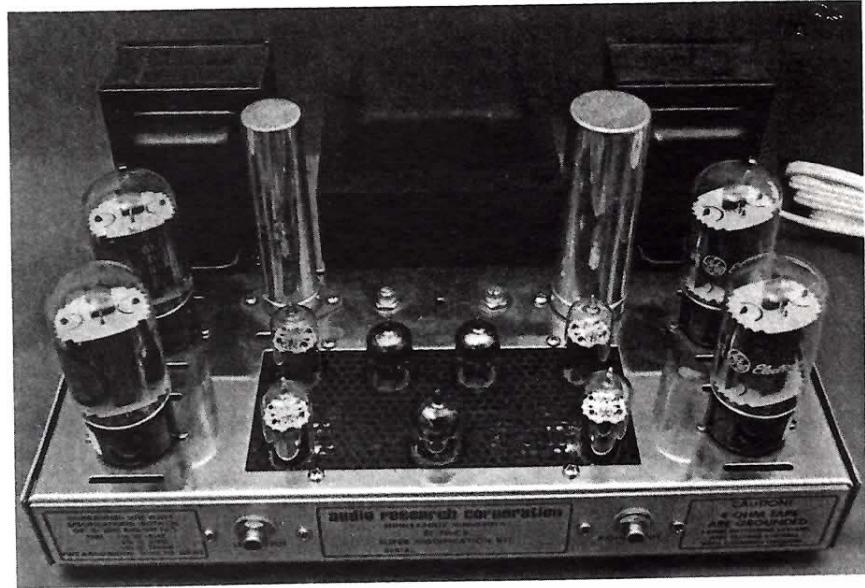

Photo A. The completed Audio Research ST-70-C3 stereo amplifier.

70-C3 is not a modification at all. It's a transformation. The result isn't a modified Dynaco product--it's an Audio Research power amplifier using Dyna transformers and chassis.

Is the transformation worth the effort and the cost?

Dynaco Stereo 70s are bringing about \$50 to \$70 second hand these days and the modification kit price raises that to well above \$200. For this quality of ampli-

fier, however, the price tag is not out of line. The parts in the kit are first quality and were chosen to give long service.

Those who want to build the design from scratch can probably do so for slightly less money although output transformers of the quality of the Dyna product are relatively rare. The Dynaco line began around the outstanding features of their output transformers. Dyna does not any longer sell output transformers

FIG. 1

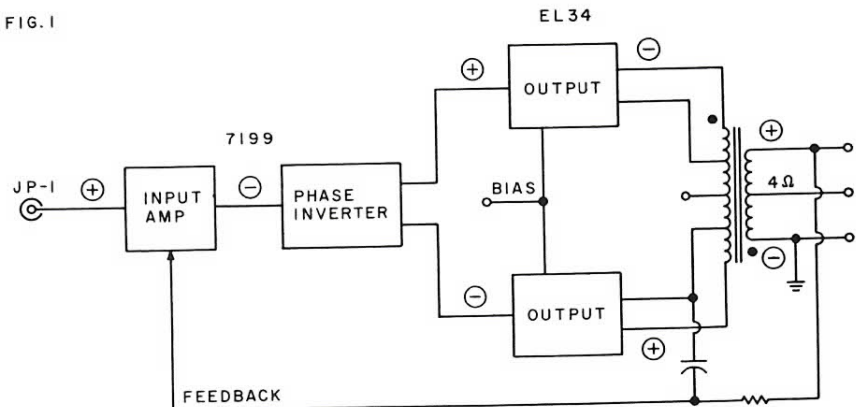

Fig. 1. Block diagram of the Dynaco Stereo 70, one channel. The + and - signs on this and Figs. 2 and 3 denote instantaneous signal polarity with respect to input JP-1. Power supply is unregulated, 60 μ F total capacitance.

to experimenters as they did in the early days, however. Those who find good substitutes such as the old Peerless, Acrosound, or UTC can make themselves a first-class unit with this design, as is, or with variations.

Before you begin make certain your old Dyna ST-70 has reusable parts that are working satisfactorily enough to perform well in the new unit. The three transformers, the fuse post, on/off switch and line cord ought to be checked if the unit is not in operating condition. Check continuity with an

Ohmmeter. If the transformer windings show continuity, they're probably O.K. When you purchase your used unit, ask for the construction manual. Dyna will sell you a new one for \$2 postpaid.

If the unit is functioning, check the voltages against those in the manual. If all is within $\pm 20\%$ of normal, your unit is alright. You can also pull all the tubes (or the GZ-34 only) turn it on and carefully check all the A.C. voltages at the tube sockets.

Next you should check the color of the transformer leads, particu-

larly those on T1 which tend to fade. If they are faded badly it is a good idea to label them before you unsolder them. If any have seriously decayed insulation you may wish to cover them with shrink tubing or replace them.

Remove the end bells and cut the wire to 1" length, strip $\frac{1}{2}$ " and twist together inline neatly with a new wire of the same size and color to replace the old one. Solder together and slip a piece of 2" heat shrink tubing over the splice and as near to the winding core as possible. Shrink the tubing and replace the bell.

FIG. 2

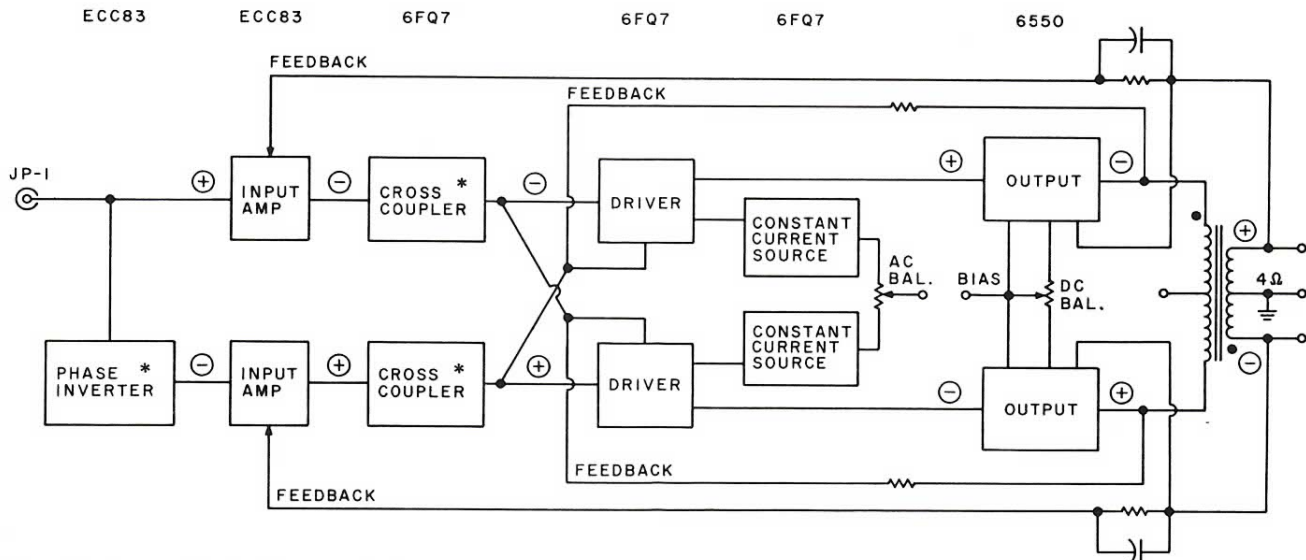

Fig. 2, above. Block diagram of the Audio Research D-76A, one channel. *Indicates that stage is comprised of two triode sections. Output stage has partial cathode coupling. Power to all low level stages and output stage screen grids is tightly regulated by a zener controlled 6550 series regulator tube. Output tubes are fed by 900 μ F total capacitance.

FIG. 3

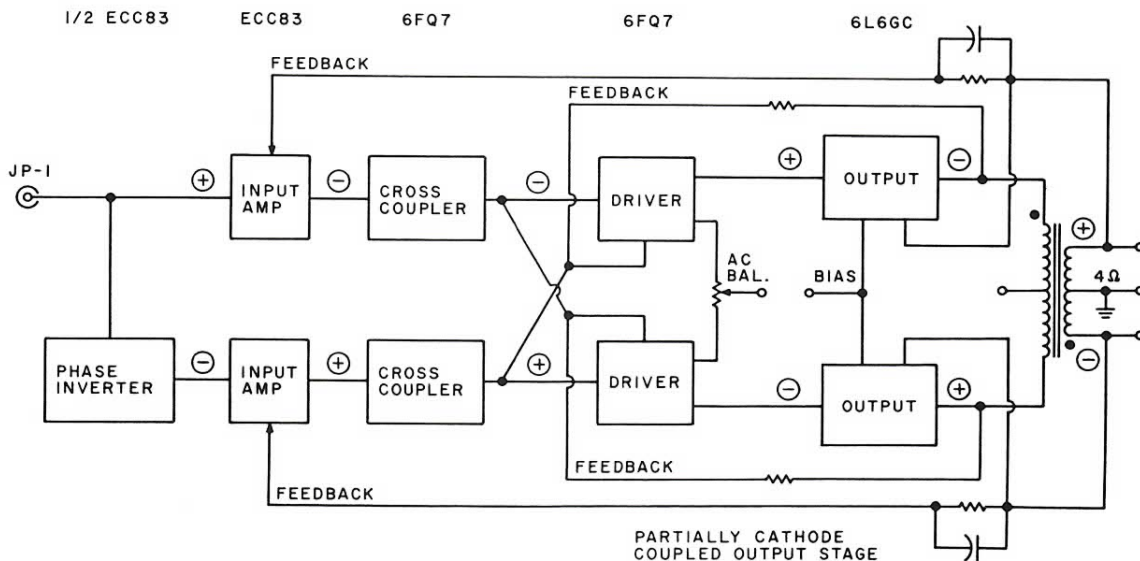

Fig. 3. Block diagram of the Audio Research ST-70-C3 modification to the Dynaco Stereo 70's circuitry. Input stages receive zener regulated voltage. All others, including output tubes, are fed by at least 230 μ F total capacitance. Remarkably, they managed to squeeze everything into the original chassis.

BEFORE YOU BEGIN

Please read through the manual thoroughly first. Check the parts in the kit against the parts list on page 7.

You will need a 40W pencil iron, a supply of rosin core solder, wire cutters, small and medium screwdrivers (Phillips and regular blade), long nose pliers, and wire stripper. Several nut drivers are helpful but not absolutely essential.

The conversion can be accomplished in about a dozen to 15 hours. Please allow yourself plenty of time to do a thorough and correct job. Check off each step as you do it. Take recesses from the work from time to time.

Bad solder joints are the cause of 90% of the problems in kit construction. Take time to make good joints. Heat the terminal first, apply solder to the terminal or wire, never to the soldering iron. The solder eyelets on the circuit board are all filled with solder. If you tin your wires with solder before attaching them to the circuit board, you should not need to add more solder to the board's eyelets. Heat the eyelet thoroughly and slip the wire into it. Check both sides of the board for a smooth, uniform joint.

INTRODUCTORY NOTES

1. Make sure the unmodified ST-70 is working, or be *absolutely sure* that the parts listed below are not defective or damaged.

2. All locations and component designations will refer to the drawings and schematics in these instructions.

3. All directions refer to the unit upside down on the bench with rear (speaker outputs) facing you.

Original Dynaco Stereo 70 parts used in ARC ST-70-C3 modification:

- cover (see text)
- chassis
- bottom plate
- two output transformers
- power transformer
- fuse holder
- on/off switch
- line cord

SECTION A, DISASSEMBLY

A-1() Remove cover (save), tubes, and bottom plate (save).

A-2() Refer to Table 2 and make sure all transformer lead colors are identifiable. Re-mark or tag any faded leads that might cause confusion later.

A-3() Remove the two metal hold-down clips at the power transformer mounting screws. Return the lock washers and nuts. Unsolder all power transformer leads (you'll need a large iron or "gun" for this) except the black pair that connects to the fuse holder and switch.

A-4() Unsolder all output transformer leads.

A-5() Cut the two wires attached to each channel's output terminal board.

A-6() Unsolder the small bare wire connecting the ground lug of the large chassis mounted capacitor with the chassis

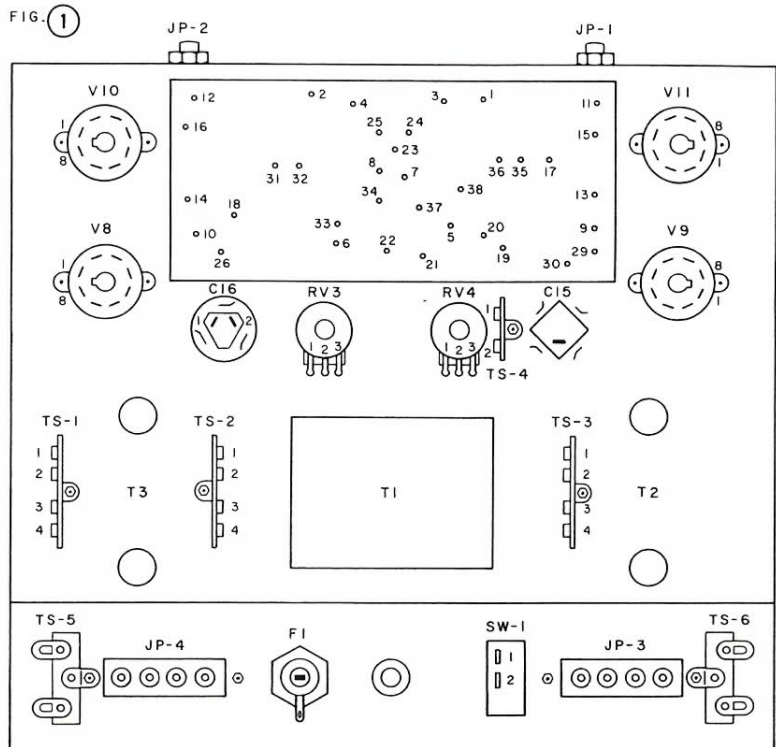

ground lug. Clip all other wires and resistors at the capacitor terminals. Straighten the mounting lugs and remove.

A-7() Remove the output transformers. IMPORTANT, their lead lengths are different, so make sure to mark them so they can later be returned to the same side of the chassis from which they were removed.

A-8() Using hand tools, remove EVERYTHING from the chassis except the last four items in the parts list above. The P-C board, tube sockets and other wiring will simply fall out as a unit.

TABLE II
 Transformer wire colors

Power Transformer	
Wires:right hole	Wires:left hole
2 Long brn.	2 Long black
1 Short red/yel	2 Long green
1 Short red/bk	2 Med white
1 Long grn/yel	2 Med red
1 Long brn/yel	

Output Transformers

Top hole	Bottom hole
1 Red	1 Black
1 Blue	1 Brown
1 Green	1 Orange
1 White/Blue	1 Yellow
1 White/Green	

FIGURE 2

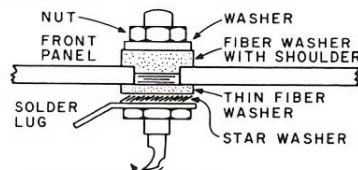

MAY BE BENT OVER SLIGHTLY FOR P-C BOARD CLEARANCE

A-9() OPTIONAL--some builders may now wish to temporarily unmount the four remaining items from the chassis for proper cleaning, transformer re-painting, line cord replacement, &c. (Remove the fuse from fuse holder before unsoldering leads.) If this is done, save the line cord installation until the last wiring step. Chassis handling during modification will be less cumbersome without a dangling line cord.

A-10() Clean chassis thoroughly with any good brand of home or automotive chrome cleaner or metal polish.

SECTION B, MECHANICAL ASSEMBLY

Refer to Fig.1 for the following steps. An "up" location direction means away from the chassis. "Down" means into the chassis.

Note: These instructions begin with a completely stripped chassis. If you stopped disassembly with Step A-8 in the previous section, ignore the steps describing the mounting of those four parts.

B-1() Mount the power slide switch (SW-1) in its original hole using the original 4/40 x 3/8 screws; position it so the end with the solder terminals faces down.

B-2() Mount the fuse holder with its side terminal facing "up." (Rubber washer, if any, is outside chassis.)

B-3() Mount the two short shafted potentiometers (RV3 and RV4) in the two holes in front of the power transformer using panel washers and nut. Position so the tabs face the power transformer hole.

B-4() Mount two four-lug terminal strips (T.S.-1&2) to the left of the power transformer hole as indicated, using for each a 6/32 x 1/4" Phillips screw, #6 flat washer, star washer, and nut.

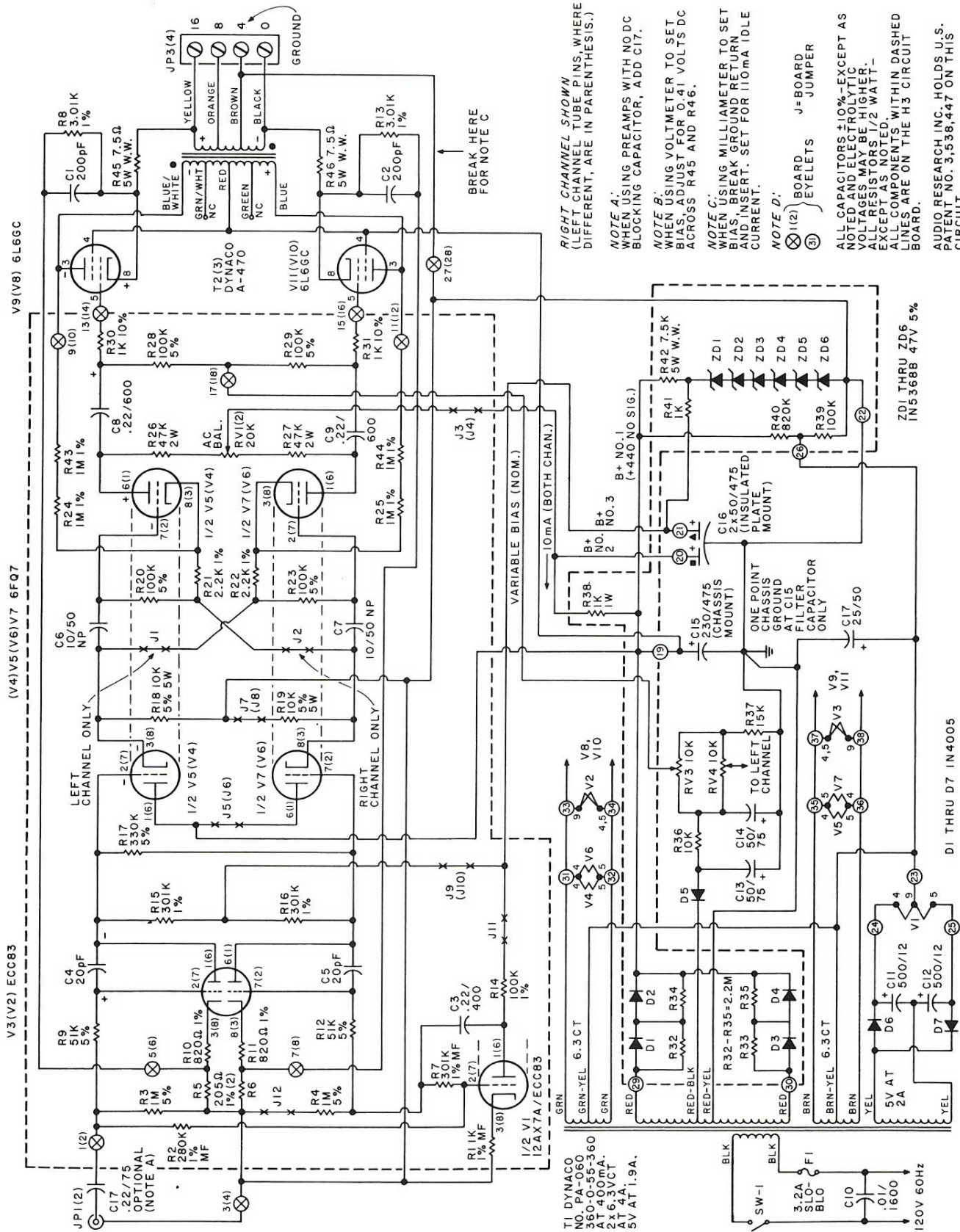

PROPRIETARY NOTICE: This diagram contains patented and/or other information considered proprietary by Audio Research Corporation and is furnished on a confidential basis for identification purposes only. Audio Research does not object to the home experimenter building a unit with their patented circuitry for his own use. However, no license is granted herein for any commercial use. Building units for resale or any custom or manufacturing effort is prohibited by law.

RIGHT CHANNEL SHOWN
(LEFT CHANNEL TUBE PIN, WHERE DIFFERENT, ARE IN PARENTHESIS.)

NOTE A:
WHEN USING PREAMPS WITH NO DC BLOCKING CAPACITOR, ADD C17.

NOTE B:
WHEN USING VOLTMETER TO SET BIAS, ADJUST FOR 0.41 VOLTS DC ACROSS R45 AND R46.

NOTE C:
WHEN USING MILLIAMETER TO SET BIAS, BREAK GROUND RETURN AND INSERT 10mA IDLE CURRENT.

NOTE D:
⊗ (1)(2) BOARD JUMPER
⊙ (3) EYELETS

ALL CAPACITORS ±10%—EXCEPT AS NOTED OTHERWISE. ALL RESISTORS ±1% UNLESS OTHERWISE NOTED. ALL COMPONENTS WITHIN DASHED LINES ARE ON THE H3 CIRCUIT BOARD.

AUDIO RESEARCH INC. HOLDS U.S. PATENT NO. 3,538,447 ON THIS CIRCUIT.

ZD1 THRU ZD6
IN5368B 47V 5%

DI THRU D7 IN4005

Table III
Eyelet Connections

Eyelet	To
1	Input (+) Right
2	Input (+) Left
3	Input (-) Right
4	Input (-) Left
5	Pin 1, V9
6	Pin 1, V8
7	Pin 1, V11
8	Pin 1, V12
9	Pin 3, V9
10	Pin 3, V8
11	Pin 3, V11
12	Pin 3, V12
13	Pin 5, V9
14	Pin 5, V8
15	Pin 5, V11
16	Pin 5, V10
17	Center term. RV3

18	Center term. RV4
19	+ term. of C15
20	□ term. on C16
21	Δ term. on C16
22	Gnd. lug on C15
23	To Eyelet 26
24	Red wire to +C11/D6
25	Blk. wire to -C12/D7
26	To Eyelet 23 and +C17
27	N. Connection?
28	No Connection
29	One Red lead of T1 (Extended)
30	Other Red lead of T1
31	To Eyelet 33 and Pin 7, V8
32	To Eyelet 34 and Pin 2, V8
33	To Eyelet 31
34	To Eyelet 32
35	To Eyelet 37 and Pin 7 of V9
36	To Eyelet 38 and Pin 2 of V9
37	To Eyelet 35
38	To Eyelet 36

AMPLIFIER SECTION, PARTS LIST, One Channel

Resistors (All 10% ½W exc. as noted)

R1	1k, ±1%MF
R2	280k, ±1%MF
R3	1M, ±5%
R4	1M, ±5%
R5	205Ω ±1%
R6	205Ω, ±1%
R7	301k, ±1%MF
R8	3.01k, ±1%
R9	51k, ±5%
R10	820Ω, ±1%
R11	820Ω, ±1%
R12	51k, ±5%
R13	3.01k, ±1%
R14	100k, ±1%
R15	301k, ±1%
R16	301k, ±1%
R17	330k, ±5%
R18	10k, ±5%, 5W
R19	10k, ±5%, 5W
R20	100k, ±5%
R21	2.2k, ±1%
R22	2.2k, ±1%
R23	100k, ±5%
R24	1M, ±1%
R25	1M, ±1%
R26	47k, 2W
R27	47k, 2W
R28	100k, ±5%
R29	100k, ±5%
R30	1k, ±10%
R31	1k, ±10%
R43	1M, ±1%
R44	1M, ±1%
R45	7.5Ω, 5W, ww
R46	7.5Ω, 5W, ww
RV1	20k Pot. Lin.

CAPACITORS, All are ±10% except as noted

C1	200pF
C2	200pF
C3	.22μF @400V
C4	20pF
C5	20pF
C6	10μF @50V Non Polarized
C7	10μF @50V Non Polarized

C8	.22μF @600V
C9	.22μF @600V
C17	(Optional for preamp without DC blocking in O/P) .22 @75
T2	Dynaco A-470 Pri. 6600Ω, Sec 1,4,8,16Ω

TUBES (Numbers in parenthesis are the other channel)

V1-	½ 12AX7/ECC83
V3(2)	12AX7/ECC83
V5(4)	6FQ7
V7(6)	6FQ7
V9(8)	6L6GC General Electric
V11(10)	6L6GC General Electric

POWER SUPPLY (Two Channel)

R32	2.2 Meg
R33	2.2 Meg
R34	2.2 Meg
R35	2.2 Meg
R36	10k
R37	15k
R38	1k, 1W
R39	100k
R40	820k
R41	1k
R42	7.5k, 5W, ww
RV3	10k Lin
RV4	10k Lin

CAPACITORS

C10	.01μF @600V
C11	500μF @12V Electrolytic
C12	500μF @12V Electrolytic
C13	50μF @75V Electrolytic
C14	50μF @75V Electrolytic
C15	230μF @ 475V Electrolytic
C16	2X50μF @475V Electrolytic

DIODES

D1-D7	1N4005
ZD1-6	1N5368B, 47V, ±5%, 1W

Transformer: Dynaco PA-060
360-0-55-360 @400mA
2X6.3V CT @4A
5V @1.9A

PARTS CHECK LIST

Tubes

4	6FQ7/6CG7 tubes
4	(2 matched pairs) 6L6GC tubes
2	12AX7/ECC83 tubes

Resistors

4	3.01KΩ 1% RN65
1	10K 5% (Brown, Brn. Org., Gold)
1	15K 5% (Brown, Grn. Org., Gold)
4	7.5Ω 5W

Capacitors

1	.01μF/1600V mylar
1	25μF/50V Electrolytic
2	500μF/12V Electrolytic
2	50μF/150V Electrolytic
1	230μF/475V Can Electrolytic
1	50μF/50μF/475V Can Electrolytic
4	200pF ±2% silver mica

Diodes

3	1N4005
---	--------

Controls

2	Short Shaft Controls 10K Lin.
---	-------------------------------

1	Assembled Circuit Board
---	-------------------------

Hardware

20	Nylon cable ties
1	3" clear teflon tubing
1	10" clear #10 tubing
1	3" clear 1/8" shrink tubing
1	4" black #18 tubing
4	octal tube sockets
4	large rubber feet
1	phenolic capacitor mtg. plate
1	3¼x6½ perforated metal plate
1	front panel cover plate
1	line cord fastener
2	Output terminal blocks
3	2-lug terminal strips
3	4-lug terminal strips
2	RCA panel jacks(w.3/8" mtg)*
2	lg. star washers 3/8"
2	lg. solder lugs 3/8"
2	thick shoulder fiber washers 3/8"
2	thin fiber washers 3/8"
4	metal panel washers 3/8"
4	3/8" nuts
4	hex threaded pillars 1"
15	6/32 x ¼" phillips head screws
8	6/32 x 3/8" phillips head screws
4	6/32 x 3/4" phillips head screws
15	6/32 nuts
23	6/32 star lock washers
4	6/32 flat washers
4	8/32x½" pan head screws
4	8/32 star washers
4	8/32 nuts

Assorted wire as needed in a variety of colors

*Note: Some later kits may be supplied with input jacks with ¼" mounting bushings. These will be supplied with two each: ¼" hex nuts, star washers, solder lugs, fiber shoulder washers, thin fiber washers and metal panel washers, in lieu of some of the 3/8" hardware items listed above.

Continued from page 5

B-5() Mount a four-lug terminal strip (T.S.-3) to the right of the power transformer hole as indicated. Fasten as T.S.-1&2.

B-6() Mount a two-lug terminal strip (T.S.-4) in the hole to the right of potentiometer RV4. Position as indicated. (Fasten as before.)

B-7() Mount the two output terminal blocks using 6/32 x 3/4" phillips screws, star washers, and nuts. The remaining two two-lug terminal strips (T.S.-5&6) should be mounted under the nut of each screw nearest to the chassis corners.

B-8() Mount the four new octal tube sockets (use Dynaco's 4/40 x 1/4" screws, star washers, and nuts). Position so all keyways face toward the nearest side edge as indicated. At each socket, bend down the four metal ground lugs toward the chassis, as they are not used.

B-9() Mount C15 (230µF/475V can) in its hole as indicated and twist the mounting tabs. Using a 100W soldering gun, solder the lower left mounting terminal to the steel chassis. Slight filing of the steel chassis may be necessary for a good solder joint. An alternative to direct chassis soldering is to run a piece of wire from the same C15 terminal to the center hole of the grounded mounting tab of T.S.-4. Solder both ends well.

B-10() Mount the phenolic capacitor mounting plate above the chassis for C16. Position so the apex of the triangular cutout faces to the rear of the chassis (6/32 x 1/4" phillips, star washers, and nuts).

B-11() Mount C16, the dual 50µF/475V can capacitor, onto the phenolic mounting plate. Twist the three mounting lugs to secure it in place.

B-12() *Input jack assembly.* See Fig.2. Assemble the input jack parts onto the new front panel in the following order:
--onto each jack, slip a large ground lug, star washer, and thin fiber washer.
--insert the jacks through the holes from the rear.

--from the front, slip on a thick fiber washer (shoulder side toward the panel), panel washer, and nut.
--tighten carefully, making sure that the shoulder seats into the hole properly.

Align the ground lugs so that they point toward each other. Bend these up slightly (1/8"). The opening on the center terminal should face the ground lug.

B-13() Mount the front panel over the front chassis edge using four 6/32 x 1/4" phillips screws, star washers, and nuts.

B-14() Mount the anodized perforated cover plate over the old P-C board cutout using four 6/32 x 1/4" phillips screws, #10 flat washers, star washers, and threaded hex pillars. Mount it from the inside. with all washers under the pillars. Note: Although this plate is not symmetrical, it is deceptively close. Mount with the four large holes toward the rear.

B-15() Plug all tubes into the P-C board and temporarily position it onto the pil-

FIG. 3

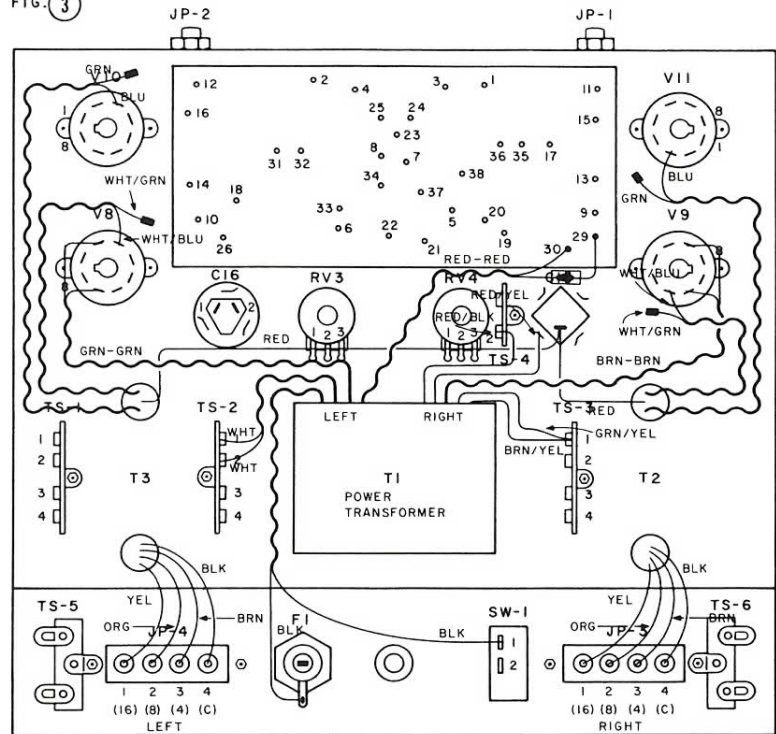

lars to check that the perforated cover plate has been installed correctly. If the tubes do not fit through the holes, the plate is upside down.

Special note: Take a look at the schematic on page 6 of this booklet. Read notes B and C. You may, according to those, use one of two methods to check for correct bias level on the output tubes: In Method B you use a voltmeter, attaching its leads across R45 and then R46, adjusting RV3 (for the right channel) for 0-41 Volts. In Method C you break the lead from eyelet 27 (right channel) to the 4Ω (grounded) terminal of the output transformer.

Optional: If you prefer Method C, you may want to install a permanent closed circuit jack in the chassis at locations indicated on Fig.8. The jack's tip and ring are shorted together when no plug is inserted. When a plug is inserted its tip and ring are connected to your milliammeter to measure current flow in the line, which should be 110mA. See Fig.8 for suggested location of the two jacks.

SECTION C, POWER TRANSFORMER WIRING

Wiring Note: The use of additional electronic type Rosin Flux will sometimes facilitate soldering to aged and oxidized transformer wires. (DO NOT USE ordinary acid core solder or acid flux which damages electronic gear.)

Wiring Plan: Note in the wiring drawings how most wiring is routed as a "T" channel from the center of the chassis to the sides and around to the tubes and/or output terminals (see Fig.5 and photos). When routing a piece of wire, try to follow the plan.

Turn to Fig.3.

C-1() Remount the power transformer in its original position using the original star washers and nuts.

C-2() From the right hole, find and identify the following wires:

- 2--long BRN
- 1--short red/yel
- 1--short red/blk
- 1--long grn/yel
- 1--long brn/yel

The lengths of all wires will probably be sufficient, although the last two may need shortening.

C-3() Route and insert the short red/blk wire into the lower rivet hole of lug 2 of T.S.-4. (Solder.)

C-4() Route and connect the short red/yel wire to the lower left (previously soldered) ground lug of the 230µF can capacitor. (Solder.)

C-5() Twist the two long brown wires together and route to V9. Connect one to pin 2 and the other to pin 7. Do not solder.

C-6() Route and insert the two long grn/yel and brn/yel wires (shortening if necessary) into the lower rivet hole of lug 1 on T.S.-3. Do not solder yet.

C-7() From the left hole, find and identify the following wires:

- 2--long black
- 2--long green
- 2--med white
- 2--med red

C-8() Twist the white pair together. Route them to T.S.-2. Insert one into the lower rivet hole of lug 1 and the other into the lower rivet hole of lug 2. (Solder both.)

FIG. 4

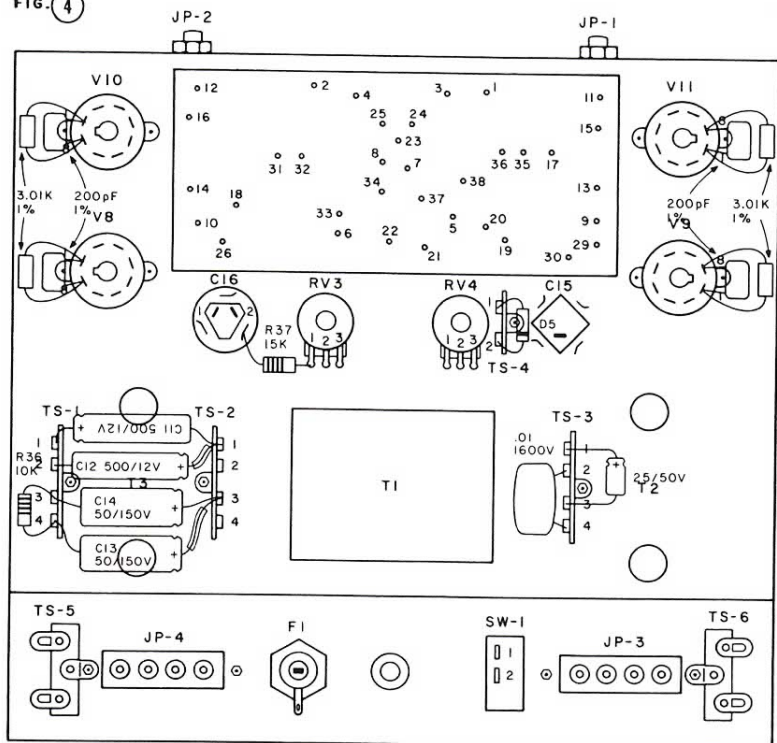

C-9() Twist the black pair together. Route near T.S.-2 and insert the shorter wire into the side terminal of fuse holder F1. (Solder.)

C-10() Route and connect the longer black wire to the lower terminal (#1) of the on-off switch. (Solder.)

C-11() Twist the green pair together and route to V8. Connect one wire to pin 2 and the other to pin 7. Do not solder.

C-12() The two red leads remain unconnected at this time. Tuck them out of the way somewhere.

SECTION D, OUTPUT TRANSFORMER WIRING

D-1() Mount the two output transformers in their original positions using 10/32 x 3/8" screws, #10 flat washers, star washers, and nuts. The four short leads should exit the rear holes. The transformer with the longest red lead *must* be mounted on the left side of the chassis (over T.S. 1&2).

D-2() Select the left output transformer. Connect the four short output transformer wires to the output terminal in the following sequence: from left to right, 16, 8, 4, C: yel, org, brn, blk. Solder *only* the org wire. Since the other wires are stiff with solder, a mechanical connection may be difficult. You may either solder sparingly and neatly now, keeping in mind that other connections will be made later, or trim and restrip them if they are long enough.

D-3() Repeat the above operations for the other output transformer.

D-4() Locate the green and grn/wht wires from the left output transformer. Snip off any bare wire protruding from the insulation at the wires' ends. (These wires will

not be used in this modification.) Insert each wire two-thirds of the way into a 5/8" piece of clear heat-shrink tubing. Heat with a very hot heat source until the tubing shrinks (a match will work if a heat-shrink gun is not available). Crimp the extra one-third together with pliers while the tubing is still soft, making an insulating cap over the wires' ends.

D-5() Repeat the above operation for the other output transformer.

D-6() Locate the long red wire from the left output transformer. Route it to C15, the large 230μF can capacitor, and connect it to the center terminal. (Do not solder.)

D-7() Repeat the above operation for the right output transformer.

D-8() From the left output transformer, twist the blue/wht and grn/wht wires together. Route to V8 and connect the blue/wht wire to pin 3. Tuck the capped grn/wht wire out of the way.

D-9() Repeat the above step at the right output transformer, but route the blue/wht and grn/wht pair to V9.

D-10() From the left output transformer, twist the blue and green wires together. Route to V10 and connect the blue wire to pin 3. Tuck the capped green wire out of the way.

D-11() Repeat the above step at the right output transformer, but route the blue and green pair to V11.

SECTION E, COMPONENT MOUNTING

Turn to Fig.4.

E-1() Mount C10, the .01μF/1600V mylar capacitor, on T.S.-3. Insert the leads through the lower rivet holes of lugs 2 and 4. Trim and solder.

E-2() Mount C17, the 25μF/50V electrolytic capacitor, on T.S.-3 between lugs 1 and 3. Positive end connects to lug 1. Trim and solder.

E-3() Mount C11, a 500μF/12V electrolytic, between lug 1 of T.S.-1 and lug 1 of T.S.-2. Position as shown in Fig.4 with the + end connected to T.S.-1.

E-4() Mount C12, the other 500μF/12V electrolytic, between lug 2 of T.S.-1 and lug 1 of T.S.2. Position as shown in Fig.4 with the + end connected to T.S.-2. Insulate the + lead with a 3/8" long piece of small black spaghetti. Solder the connection at lug 1, T.S.-2.

Turn to Fig.5.

E-5() Mount D6, a 1N4005 diode, between lug 1, T.S.-1, and lug 2, T.S.-2, with the banded end connected to T.S.-1. Solder (S-2) the connection at T.S.-1.

E-6() Mount D7, a 1N4005 diode, between lug 2, T.S.-1, and lug 2, T.S.-2, with the banded end connected to T.S.-2. Solder both connections (S-2)(S-2).

Turn to Fig.4.

E-7() Mount C14, a 50μF/150V electrolytic, between lug 3 of T.S.-1 and lug 3 of T.S.-2, with the + lead connected to T.S.-2.

E-8() Mount C13, the other 50μF/150V electrolytic, between lug 4 of T.S.-1 and lug 3 of T.S.-2 with the + lead connected to T.S.-2. Insulate the + lead with a 3/8" piece of spaghetti. Solder (S-2) the connection at T.S.-2.

E-9() Mount R36, the 10K 1/4W resistor (brown-black-orange), between lugs 3 and 4 of T.S.-1. Solder both connections (S-2) (S-2).

E-10() Connect across pins 1 and 8 of each of the four octal sockets a 3.01K 1% resistor and a 200pF 1% capacitor. Use only the top holes of the socket pins and solder in place. (S-2) for each pin.

E-11() Mount the remaining 1N4005 diode between the two lugs of T.S.-4, with the banded end connected to lug 2. Solder. (S-1)(S-1)

E-12() Mount the 15K (brn/grn/org) 1/4W resistor between the lower right ground lug of C16 can capacitor and terminal 1 of VR3. Insulate each lead with half-inch long pieces of spaghetti.

E-13() Mount the left channel's R45, a 7.5Ω 5W resistor, from the left channel's 16Ω output terminal to lug 1 on T.S.-5. Use a half-inch piece of spaghetti over the lead connected to the 16Ω terminal. Solder the 16Ω connection. (S-2)

E-14() Mount the left channel's R46, a 7.5Ω 5W resistor, from the left channel's "C" output terminal to lug 2 on T.S.-5. Solder the C terminal connection. (S-2)

E-15() Mount the right channel's R45, a 7.5Ω 5W resistor, from the right channel's 16Ω output terminal to lug 1 on T.S.-6. Solder the 16Ω connection. (S-2)

E-16() Mount the right channel's R46, a 7.5Ω 5W resistor, from the right channel's "C" output terminal to lug 2 on T.S.-6. Use a 3/4" piece of spaghetti over the lead connected to the "C" terminal. Solder the C terminal connection. (S-2)

SECTION F, MAIN CHASSIS WIRING

Wiring Note: All lengths include ¼" stripped ends. When twisted pair lengths are specified, the lengths refer to total length after twisting. As a guide, lengths of untwisted wire are given at each step (in parentheses) that will twist together to near the required length. See Step F-3 for an example.

Turn to Fig. 5.

F-1() Cut a 5" piece and a 9" piece of brn. wire. Solder (S-2) the 5" piece to lug 2 on T.S.-3. Solder (S-1) the 9" piece to lug 4 on T.S.-3. Twist together four to six times. Attach the shorter wire to upper (#2) switch contact. Route as shown and attach longer wire to the center terminal of the fuse holder.

Turn to Fig. 7.

F-2() Solder (S-1) a 5½" brn wire to pin 7 (V11). Solder (S-1) a 5½" brn wire to pin 2 (V11). Twist together four to five times and attach one wire to pin 7 (V9) and the other to pin 2 (V9).

F-3() Make up a twisted brown pair that has a total length of 16" (about 18" initial length for a moderately tight twist). At one end, solder (S-3) one wire to pin 2 (V11) and the other to pin 7 (V11) (S-3). Stash this twisted pair out of the way temporarily, as it will connect to the PC board which has not been mounted yet.

F-4() Solder (S-1) a 5½" grn wire to pin 7 (V10). Solder (S-1) a 5½" grn wire to pin 2 (V10). Twist together four or five times and attach one wire to pin 7 (V8) and the other to pin 2 (V8).

F-5() Make up a twisted green pair that has a total length of 16" (about 18" initial length for a moderately tight twist). At one end, solder one wire (S-3) to pin 2 (V8) and the other wire (S-3) to pin 7 (V8). Stash this twisted pair out of the way temporarily, as it will connect to the PC board which has not been mounted yet.

Turn to Fig. 5.

F-6() Solder (S-3) a 9" wht/org wire to pin 8 (V9). Route the other end to lug 1 on T.S.-6 and solder (S-2).

F-7() Solder (S-3) an 8½" wht/org wire to pin 8 (V8). Route the other end to lug 1 on T.S.-5 and solder (S-2).

F-8() Solder (S-3) an 11" wht/purp wire to pin 8 (V11). Route the other end to lug 2 on T.S.-6 and solder (S-2).

F-9() Solder (S-3) a 10" wht/purp wire to pin 8 (V10). Route the other end to lug 2 on T.S.-5 and solder (S-2).

FIG. 5

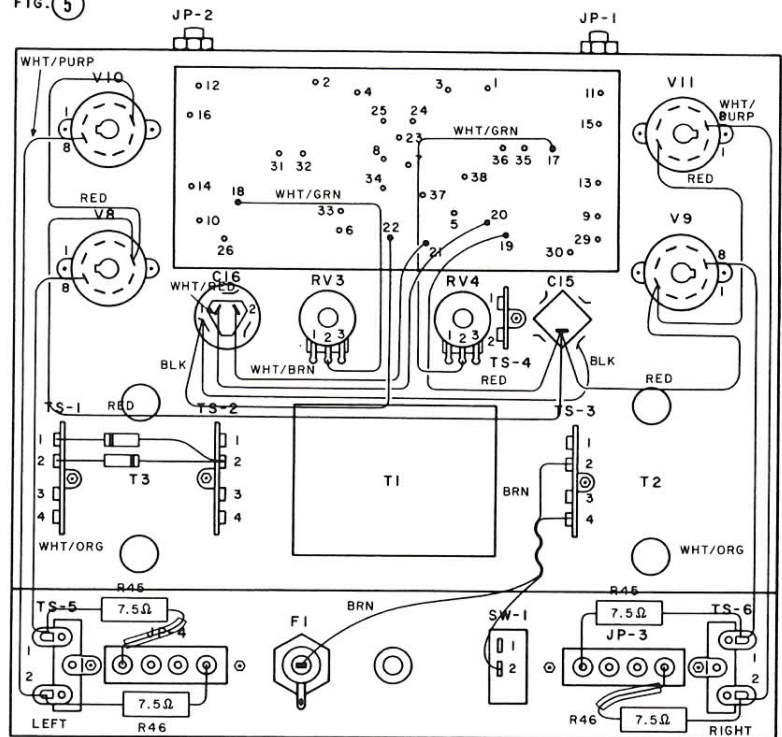

F-10() Solder (S-1) a 7" red wire to pin 4 (V11). Route to pin 4 (V9) and attach.

F-11() Solder (S-2) an 8½" red wire to pin 4 (V9). Route and attach to the center terminal of can capacitor C15.

F-12() Solder (S-1) a 7" red wire to pin 4 (V10). Route to pin 4 (V8) and attach.

F-13() Solder (S-2) a 14½" red wire to pin 4 (V8). Route to the center terminal of can capacitor C15 and attach.

Turn to Fig. 6.

F-14() Solder (S-3) a 15" purple wire to the lower (or upper if you have room) eyelet of lug 4, T.S.-1. Route to the lower eyelet of lug 1, T.S.-4, and solder (S-2).

F-15() Solder (S-2) a 3" grey wire to lug 1 of the chassis mounted bias pot RV3. Solder (S-1) the other end to lug 1 of bias pot RV4.

F-16() Attach a 3" grey wire to lug 3 of RV3. Solder (S-1) the other end to lug 3 of RV4.

F-17() Solder (S-3) an 11" grey wire to the lower eyelet (or upper if you have room) of lug 3, T.S.-1. Route to lug 3 of RV3 and solder (S-2).

F-18() Solder (S-2) a 10½" black wire to the right channel's 4Ω output terminal (brn transformer wire). Route to the chassis ground at the C15 ground lug and attach.

F-19() Solder (S-2) a 9" black wire to the lower right ground terminal of can capacitor C16 (at resistor connection). Route to the lower (or upper) eyelet of lug 3, T.S.-3, and solder (S-2).

Turn to Fig. 5.

F-20() Attach an 8½" black wire to the lower left ground terminal of C16. Route to the chassis ground at the lower right ground terminal of C15 and attach.

Turn to Fig. 6.

F-21() Solder (S-3) a 9½" black wire to the lower (upper if you have room) eyelet of lug 3, T.S.-2. Route to the chassis ground terminal (lower right) of C15 and attach.

F-22() Solder (S-2) a 17½" black wire to the left channel's 4Ω output terminal (brn transformer wire). Route to the chassis ground lower right terminal at C15 and solder (S-4). (Make certain all four black wires are soldered.)

SECTION G, GET READY FOR THE PC BOARD WIRING

Note: The following wires will be soldered at one end to eyelets on the PC board. For best results, strip one end of the wire ¼" for the following operations, and the other end should be stripped only 1/8" for a later PC board connection. This end should be pre-tinned with solder. All wires in Steps G-1 through G-11 will be first connected at one end only. The other ends will be attached to the PC board in the next section.

Turn to Fig. 7.

G-1() Solder (S-2) a 2½" blue wire to pin 3 (V11).

G-2() Solder (S-1) a 2" wht/grn wire to pin 5 (V11).

G-3() Solder (S-2) a 2" blue wire to pin 3 (V9).

FIG. 6

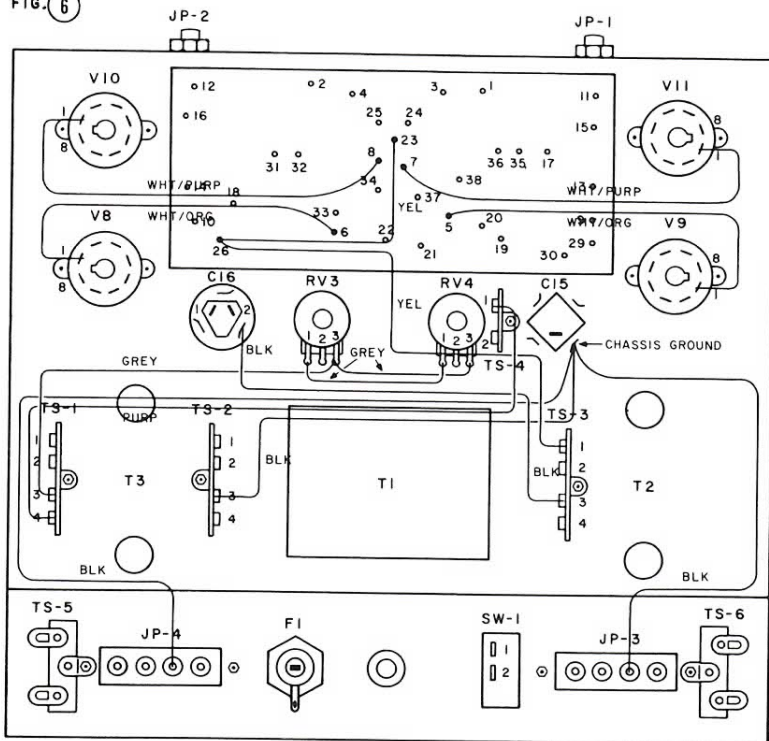

G-4() Solder (S-1) a 2" wht/grn wire to pin 5 (V9).

G-5() Solder (S-2) a 2" blue wire to pin 3 (V10).

G-6() Solder (S-1) a 2" wht/grn wire to pin 5 (V10).

G-7() Solder (S-2) a 2" blue wire to pin 3 (V8).

G-8() Solder (S-1) a 2½" wht/grn wire to pin 5 (V8).

G-9() Note: The following two operations involve soldering wires to the input jacks. Before doing so, temporarily mount the PC board (without tubes) onto the four stand-off pillars. From the top of the chassis through the tube holes adjacent to the input jacks, check to make sure that the center terminals of the jacks do not rub up against the two large .22µF/600V board-mounted capacitors. If they do, a slight bit of flattening/bending of the jack terminals may be performed.

G-10() Make up a grn & blk twisted pair 4½" long. On the ¼" stripped end, solder (S-1) the green wire to the center terminal of the right channel's input jack. Solder (S-1) the black wire to the jack's ground lug.

G-11() Make up a grn & blk twisted pair 4½" long. On one end, solder (S-1) the green wire to the center terminal of the left channel's input jack. Solder (S-1) the black wire to the jack's ground lug.

SECTION H, PC BOARD MOUNTING, TUBE TO PC WIRING

H-1() You have already installed the perforated screen over the PC cutout

hole (step B-14). Now study the assembled circuit board and note that the edge with four sockets should be nearest the center of the chassis when mounted.

H-2() Mount the PC board on the pillars with four 6/32 x ½" phillips screws, while making sure that the wires from the input jacks bend up around the board so they can be soldered. Familiarize yourself with the location of the numbered eyelets on the PC board.

H-3() Route the right channel's input twisted pair to eyelets 1 and 3 (see Fig. 7). Solder (S-1) the green wire to eyelet 1 and solder (S-1) the black wire to eyelet 3. (When soldering to the board's eyelets, hold your iron against the eyelet until the solder in it melts, then insert the wire. Hold the wire still until the solder hardens for a good joint.)

H-4() Route the left channel's input twisted pair to eyelets 2 and 4. Solder (S-1) the green wire to eyelet 2, and solder (S-1) the black wire to eyelet 4. Position these two input pairs under the lip of the chassis.

Turn to Fig. 7.

H-5() Solder (S-1) the short blue wire from pin 3 of V11 to eyelet 11.

H-6() Solder (S-1) the short wht/grn wire from pin 5 of V11 to eyelet 15.

H-7() Solder (S-1) the short blue wire from pin 3 of V9 to eyelet 9.

H-8() Solder (S-1) the short wht/grn wire from pin 5 of V9 to eyelet 13.

H-9() Solder (S-1) the short blue wire from pin 3 of V10 to eyelet 12.

H-10() Solder (S-1) the short wht/grn wire from pin 5 of V9 to eyelet 16.

H-11() Solder (S-1) the short blue wire from pin 3 of V8 to eyelet 10.

H-12() Solder (S-1) the short wht/grn wire from pin 5 of V8 to eyelet 14.

Turn to Fig. 6.

H-13() Solder (S-3) one end of a 7" wht/PRP wire to pin 1 of V11.

H-14() Solder (S-3) one end of an 8" wht/ORG wire to pin 1 of V9.

H-15() Slip a 4" piece of large spaghetti tubing over the last two wires.

H-16() Solder (S-1) the remaining end of the wht/PRP wire to eyelet 7.

H-17() Solder (S-2) the remaining end of the wht/ORG wire to eyelet 5.

H-18() Solder (S-3) one end of a 7" wht/PRP wire to pin 1 of V10.

H-19() Solder (S-3) one end of an 8" wht/ORG wire to pin 1 of V8.

H-20() Slip a 4" piece of spaghetti tubing onto the last two wires.

H-21() Solder (S-1) the remaining end of the wht/PRP wire to eyelet 8.

H-22() Solder (S-1) the remaining end of the wht/ORG wire to eyelet 6.

SECTION J, CHASSIS TO PC WIRING

Turn to Fig. 5.

J-1() Solder (S-2) one end of a 7" black wire to the lower left ground terminal of can capacitor C16. Route the other end up the PC board's center and solder to eyelet 22.

Turn to Fig. 7.

J-2() Make a twisted pair of green wires totalling 6" in length (about 7" initial length). Strip 1/8" from the four wire ends and tin. At one end solder one wire each to eyelets 33 (S-1) and 34 (S-1). Solder the wires at the other end to eyelets 31 (S-1) and 32 (S-1).

J-3() Make a twisted pair of brown wires totalling 6" in length (about 7" initial length). At one end, solder one wire each to eyelets 35 (S-1) and 36 (S-1). Solder the wires at the other end to eyelets 37 (S-1) and 38 (S-1).

J-4() Solder a 6" yellow wire between eyelets 23 (S-1) and 26 (S-1) (see Fig. 6).

J-5() Make a twisted pair of one red and one black wire totalling 13" in length (about 14½" initial length). Strip ¼" from the pair at one end, 1/8" from the other. At the ¼" end, solder the black wire to the lower eyelet (or upper if you have room) of lug 2, T.S.-1 (S-3). Solder the ¼" end of the red wire to the lower eyelet (or upper if you have room) of lug 1, T.S.-1 (S-3).

J-6() Route the red/blk pair up the center of the PC board and solder the black wire to eyelet 25 (S-1) and the red wire to eyelet 24 (S-1).

Turn to Fig.3.

J-7() Route the two remaining red leads from the power transformer to eyelets 29 and 30 on the PC board. Solder the longer wire to pin 30 (S-1). Solder a 2" or 3" extension of #18 red wire to the other lead and insulate the connection with the last piece of heat-shrink tubing. Solder this wire to eyelet 29 (S-1).

J-8() Solder (S-2) a 10" yellow wire to the upper eyelet of lug 1, T.S.-3. Route the wire up the center of the PC board and solder to eyelet 26 (S-2) (see Fig.6).

Note: Two wires each will be soldered to eyelets 26, 31, 32, 35, and 36. Make sure in each case that both are firmly soldered in a good joint.

Turn to Fig.5.

J-9() Solder (S-1) a 7½" wht/grn wire to the center terminal #2 of RV3. Route up the center of the PC board and solder (S-1) to eyelet 18.

J-10() Solder (S-1) an 8½" wht/grn wire to the center terminal #2 of RV4. Route up the center of the PC board and solder (S-1) to eyelet 17.

J-11() Solder (S-1) a 7" wht/brn wire to terminal 2 of C16. Route and solder (S-1) to PC board eyelet 21.

J-12() Solder (S-1) an 8" wht/red wire to terminal 1 of C16. Route and solder (S-1) to PC board eyelet 20.

J-13() Solder an 8" red wire to the center terminal of C15 (S-5). Route and solder (S-1) to PC board eyelet 19. (Do not confuse with J9, near eyelet 21.)

Turn to Fig.7.

J-14() Route the long brn twisted pair that is attached to V9 up the center of the PC board and solder one wire to eyelet 35 (S-2) and the other to eyelet 36 (S-2).

J-15() Route the long grn twisted pair that is attached to V8 up the center of the PC board and solder one wire to eyelet 31 (S-2) and the other to eyelet 32 (S-2).

J-16() Insert the power cord through the grommet or strain relief mounting (depending on what your kit uses) between the power switch and the fuse post. If a plain grommet is used tie a knot in the cord inside the chassis, leaving about a 4" length free. If a strain relief, mount it on the cord about 4" from the end. Strip 3/8" from each free end. Attach one to terminal 2, SW-1 (S-2). Attach the other to the end terminal of F1 (S-2).

J-17() Use the nylon ties supplied to bundle neatly most of the wires, as shown in the Fig.9 photo. Do not bundle wires going to eyelets 1, 2, 3, 4, 5, 6, 7, 8, 9, 10, 11, 12, 13, 14, 15, 16.

J-18() Insert tubes in their sockets as shown in Fig.8. Note that the output tubes are packed in pairs and should be inserted as pairs in V8/V10 and V9/V11 output sockets as shown.

J-19() We suggest that to keep the circuit board and other components as cool as possible, you drill a series of 1/8" holes on ¼" centers in the 4 x 9" area of the

FIG. 7

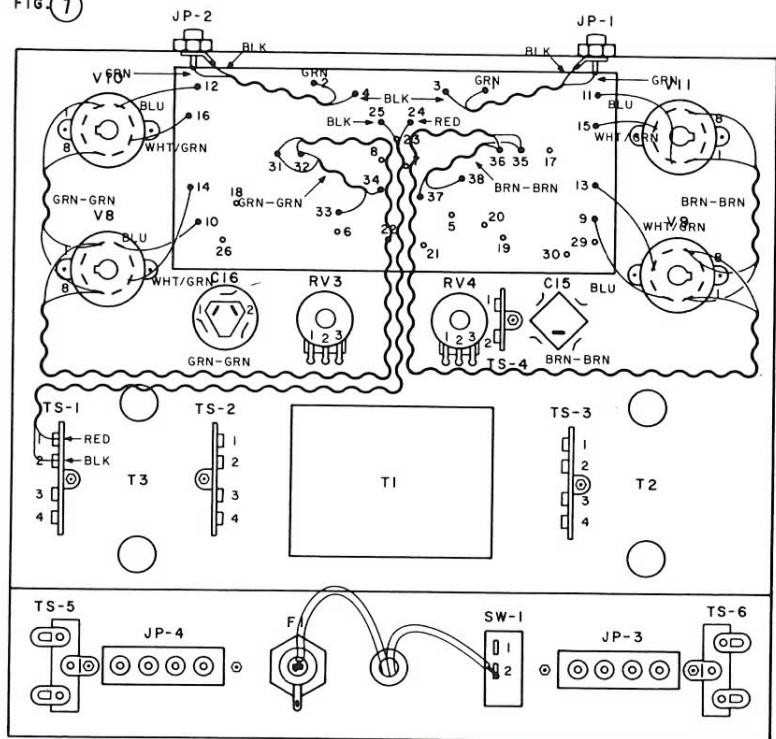

bottom plate directly beneath the circuit board. Remove all filings and burrs thoroughly.

J-20() Remove the original Dynaco feet or rubber bumpers from the bottom plate. Mount four ½" rubber feet with 8/32 x 3/8" pan head screws, lock washers, and nuts. Mount the cover on the chassis with six hex head sheet metal screws. Audio Research advises that the ST-70-C3 will operate at a lower temperature without Dynaco's perforated cage in place. If you must use the cage for safety reasons, it is a good idea to install a muffin fan on the underside of the perforated cover to keep the unit cool.

SECTION K, DC BIAS ADJUSTMENT

Adjustment of the output stage DC bias controls must be made after replacement of the output tubes or repair of associated circuitry, i.e. power supply, bias supply, etc. An adjustment or "check" can also be made periodically if it is desired to "test" or "tweak" the output stage. Although the latter procedure is not mandatory, it does monitor or compensate for the condition of the output tubes as they age.

Note: Output tubes (V8, V10) or (V9, V11) should be replaced only with *matched pairs* of 6L6GC's. If only one output tube fails, *both* must be replaced with a matched pair.

K-1() Plug the amplifier into a 120VAC power source.

K-2() Adjust the appropriate bias control(s) RV3 and/or RV4 for 110mA nominal quiescent current. Output tube current is monitored according to Notes B and C on the schematic.

K-3() Allow the amplifier to warm up for 30 minutes--a 24-hour "burn-in" is recommended before making a final adjustment with new output tubes.

K-4() Adjust bias control(s) RV3 and RV4 if necessary.

K-5() This completes the DC bias procedure. Continue with the AC balance procedure as outlined in Section L.

SECTION L, AC BALANCE PROCEDURE

Adjustment of the AC balance control must be made initially and after replacement of the output tubes or any extensive repair.

This procedure involves measuring (monitoring) the total harmonic distortion (THD) of the amplifier while adjustment is made. To prevent erroneous readings, all test equipment should be isolated from the power line ground. Since the amplifier output is "balanced" with respect to signal ground, all measurements made at the amplifier output should be referenced to the 4Ω tap only which is internally tied to circuit ground. Never externally ground, either with test cables or test equipment, the 0, 8, or 16 Ohm output terminals as this would short out one half of the amplifier's balanced push-pull feedback loop. Use only "floating" loads or test equipment when referencing same to any terminal except the grounded 4Ω terminal.

L-1() Make sure that the output stage bias controls have been properly adjusted (see DC bias procedure, Section K above) before making the AC balance adjustment.

L-2() Connect a 16Ω "dummy" load to the amplifier output of the channel under test.

L-3() Plug the amplifier into a 120VAC power source.

L-4 () Allow the amplifier to warm up for 30 minutes.

L-5 () Center the appropriate AC balance control RV1 or RV2.

L-6 () With a low distortion oscillator (<.01% residual THD) inject a 1kHz input signal. Adjust input level for full rated output--30 Watts RMS.

L-7 () Connect (float) a harmonic distortion analyzer (<.01% residual) across the 16Ω output.

L-8 () Adjust the appropriate AC balance control for minimum THD:

- <.1% @ 30 Watts RMS per channel @ 1kHz
- <.3% @ 30 Watts RMS per channel @ 30Hz
- <.1% @ 30 Watts RMS per channel @ 15kHz

Top chassis view and tube location guide.

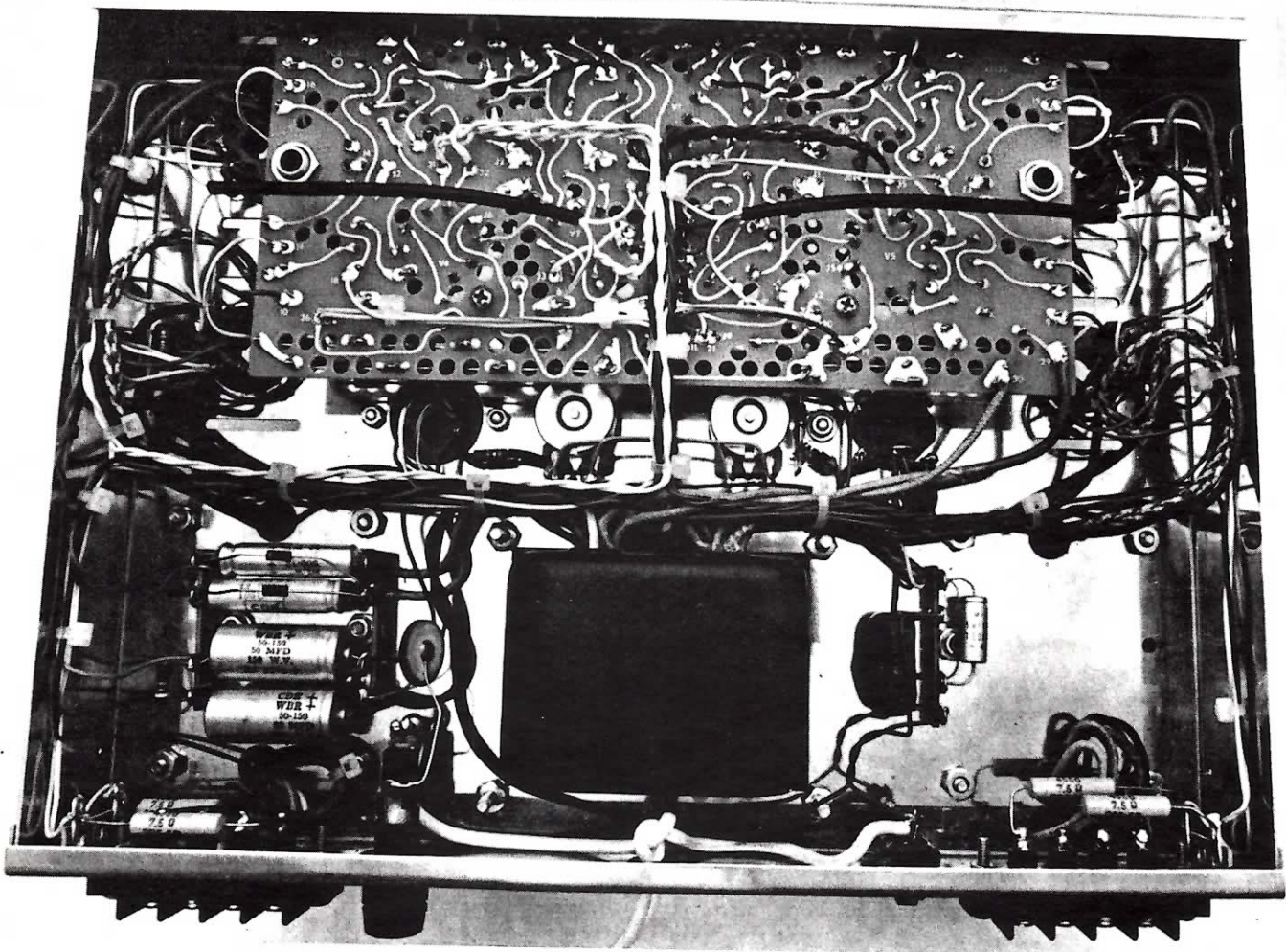
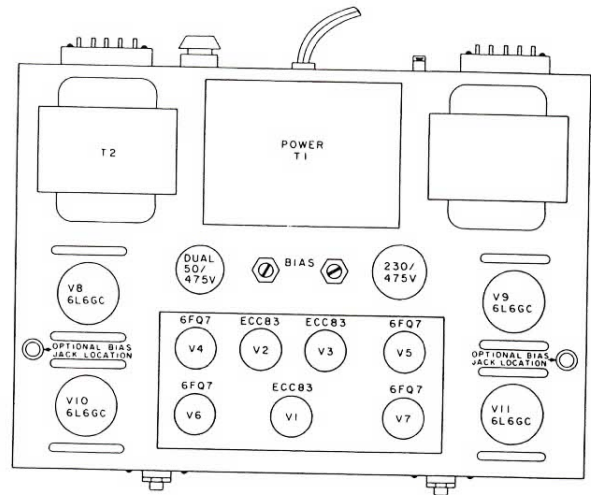

Photo B, above, is a view of the chassis after complete conversion. The thermistor connecting the fuse post terminal and Terminal strip-2 lug 4, although present in the prototype, has been dropped from the kit.

TROUBLESHOOTING TABLE

Symptom	Possible Cause
Dead, both channels	--Blown fuse (F1) --No power at plug --Defective DC filament supply --Defective ZD1 (open) --Defective transformer (T1)
Dead, one channel	--Defective tube(s) V1 through V10 --Defective output tubes V9, 10 or 9, 11 --Defective plate or cathode resistor (open) associated with V1 through V4
Blows fuses	--Wrong size and/or type fuse --Defective diode(s) in high voltage bridge rectifier (D1-4) --Defective V9 through V11 --Defective zener diode(s) in series regulator circuit. Note: If one or more are shorted, replace all zener diodes
Blows fuse at moderate to high signal levels only	--Wrong size and/or type fuse --Defective diode in high voltage bridge rectifier --Defective output tube(s) V8 through V11 (internal arcing)
Low power output	--Low B+ voltage(s) --Low regulated screen voltage
Poor sound, one or both channels	--Output tube(s) incorrectly biased --AC balance incorrectly adjusted --One or more output tubes defective. Note: Replace output tubes with factory matched pairs for lowest distortion --Defective tube(s) V1 through V11 --Defective coupling capacitor C8 or C9 --Defective output transformer T2 or T3
Hum	--Defective C26 or C27 --Defective input filter capacitor(s) 15 through 16 --Defective tube(s) V1 through V11 --Open diode(s) in high voltage bridge rectifier --Open diode in filament voltage rectifier.
Noise	--Defective tube V1 through V4 or associated plate or cathode load resistor

