



**STEREO FREQUENCY EQUALIZER
SPECTRUM ANALYZER**

SS-315X



**STEREO FREQUENCY EQUALIZER
SPECTRUM ANALYZER**

EQ-3000

Service Manual

CONTENTS

SPECIFICATIONS.....	2
ADJUSTMENT PROCEDURE.....	3~ 6
ADJUSTMENT POINTS	7
BLOCK DIAGRAM	8~ 9
WIRING BOARD LAYOUT.....	10~11
WIRING LAYOUT	12
SCHEMATIC DIAGRAM.....	13
EXPLODED VIEW	14
IC BLOCK DIAGRAM.....	15
REPLACEMENT PART LIST.....	16~24

SPECIFICATIONS

Center Frequency:	31.5, 63, 125, 250, 500, 1 K, 2 K, 4 K, 8 K, 16 kHz
Control Range:	± 15 dB minimum
Frequency Response (5 Hz ~ 100 kHz):	± 1 dB
Gain (Frequency controls flat):	± 1 dB
Harmonic Distortion (20 Hz ~ 20 kHz):	0.008% at 1 V output
Intermodulation Distortion (60 Hz:7 kHz = 4:1):	0.008% at 1 V output
Hum and Noise (Input shorted, A-weighted):	100 dB below 1 V output
Maximum Output Level (10 K ohm load):	7 V RMS minimum
Subsonic Filter:	- 18 dB/octave, 15 Hz
Input Impedance (1 kHz):	47 K ohm
Output Impedance (1 kHz):	600 ohm
Recommended Load Impedance (1 kHz):	10 K ohm or greater
Display Accuracy:	Over 31.5 to 1,000 Hz, ± 10 dB Over 2 k to 16 kHz, ± 5dB
Frequency Responce from LINE IN:	30 to 16 kHz, ± 0.5 dB
Frequency Responce with microphone supplied:	30 to 16 kHz, ± 3 dB
Peakhold duration:	Continuous
Input Impedance, MIC jack:	2.2 k ohm
Input Sensitivity, MIC jack:	0.5 mV
Input Sensitivity, LINE IN:	150 mV
Pink Noise Generator Output:	100 mV
Pink Noise Frequency Response:	Over 20 to 20,000 Hz, ± 2 dB RMS
Element Type:	Electret condenser
Directivity:	Omni-directional
Impedance, at 1 KHz:	2.2K ohm
Senitivity:	0 dB = 1 V/microbar, - 70 dB
Frequency Response, Compensated:	50 to 13,000 Hz
Bias:	1.5 V DC supplied by SS-315X
Dimensions:	17-1/8" (433 mm) width 3-1/2" (88 mm) heigh 8-3/4" (222 mm) depth
Weight:	9-1/4 lbs. (4.1 kg)
Power Requirement (Selectable):	100- 120 V/220- 240 V/50/60 Hz AC
Power Consumption:	20 W

Designs and specifications subject to change without notice.

ADJUSTMENT PROCEDURE

Before Adjustment

- Allow a minimum of 10 minutes warm-up for test the equipments and the unit under test.
- Maintain rated AC line voltage.
- Before adjusting, confirm that the regulated ± 15 V DC supplies are operating correctly.

Instruments Required

- DC volt meter
- Vacuum tube voltmeter (VTVM)
- Audio signal generator
- Oscilloscope
- Digital voltmeter
- Frequency Counter

Set the switches and controls on the unit as follows.

MONITOR selector.....SOURCE position
 DUBBING selectorSOURCE position
 EQ IN/OUT switchOff position
 REC IN/OUT switchOff position
 ATT enuater control.....Max. position
 EQ slide leversCenter (0 dB) position

METER selector.....L + R position
 METER SENSEMax. position
 HOLD switch.....Off position
 20/30 dB switch.....20 dB position
 SUBSONIC filter switchOff position
 LINE/MIC selector.....LINE position

Pink Noise Output Adjustment

- 1) Set PINK NOISE switch to ON, connect V.T.V.M to LINE OUT

- 2) Adjust the potentiometer RV01 so that 100 mV is obtained at LINE OUT (See page 7.)

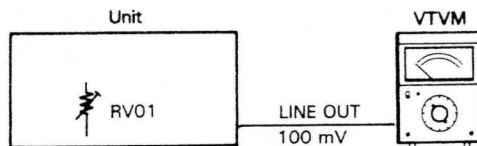

Fig. 1

Spectrum Analyzer Adjustment

- 1) Connect audio signal generator to LINE IN , apply 1 kHz 10 mV.

- 2) Adjust the potentiometer RV02 so that bar of 2 dB on 1 kHz or AVE band of SPECTRUM ANALYZER begins illuminate. (See page 7.)

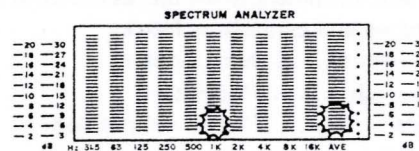
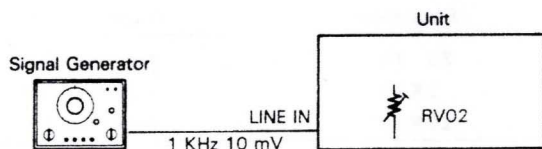

Fig. 2

Confirmation After Adjustments

● Frequency Response

1. Connect the test equipments to the unit as shown in Fig. 3
2. Set the switches and contorls as follows.
 ATT enuater control.....Max. position
 EQ IN/OUT switchIN position
 EQ slide leversFlat (0 dB) position
 LINE/MIC selector.....LINE position

Frequency	Frequency response
20 ~ 20 k (Hz)	within ± 1 dB

(LINE OUT voltage is 1 V.)

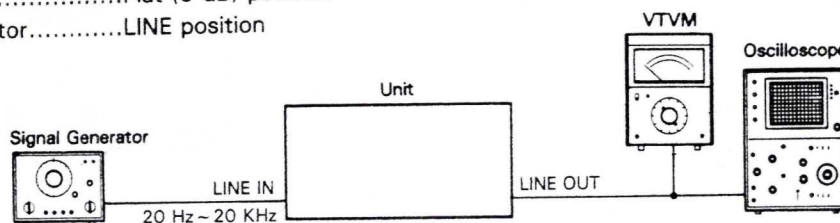

Fig. 3

● THD

1. Connect the test equipment to the unit as shown in fig. 4.
2. Set the switches and controls as follows.
 ATT enuator controlMax. position
 EQ IN/OUT switchIN position
 EQ slide controls.....Flat (0 dB) position
 LINE/MIC selector.....LINE position
 REC IN/OUT switch.....IN or OUT

Frequency	THD
20 Hz	below 0.015%
1 K Hz	below 0.015%
20 K Hz	below 0.015%

(LINE output voltage – 0.5 V rms)

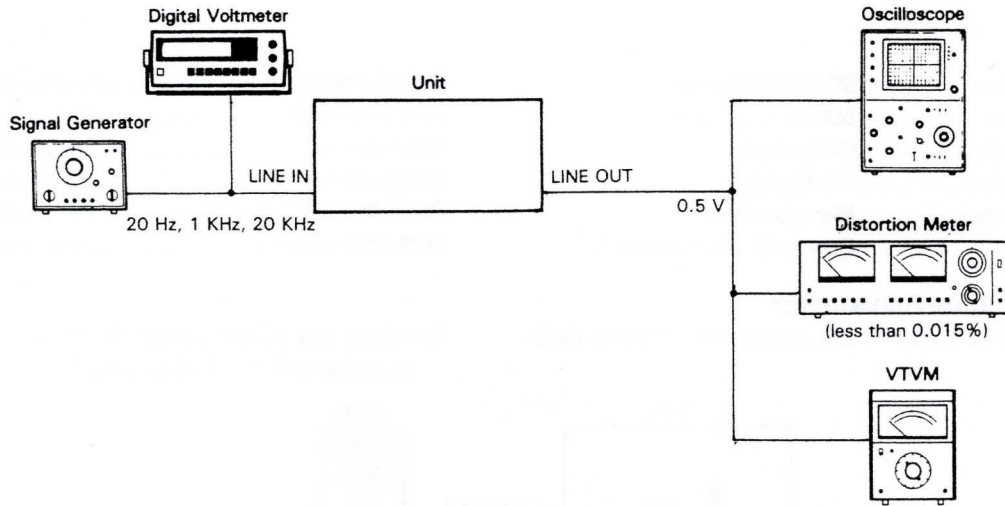

Fig. 4

● Maximum output voltage

1. Connect the test equipment to the unit as shown in fig. 5.
2. Set the switches and controls as follows.
 ATT enuator control.....Max. position
 EQ IN/OUT switchIN position
 EQ slide leversFlat (0 dB) position
 LINE/MIC selector.....LINE position

Frequency	Output voltage
20 Hz	more than 7 V
1 K Hz	more than 7 V
20 K Hz	more than 7 V

(THD 1%, 10 K ohm)

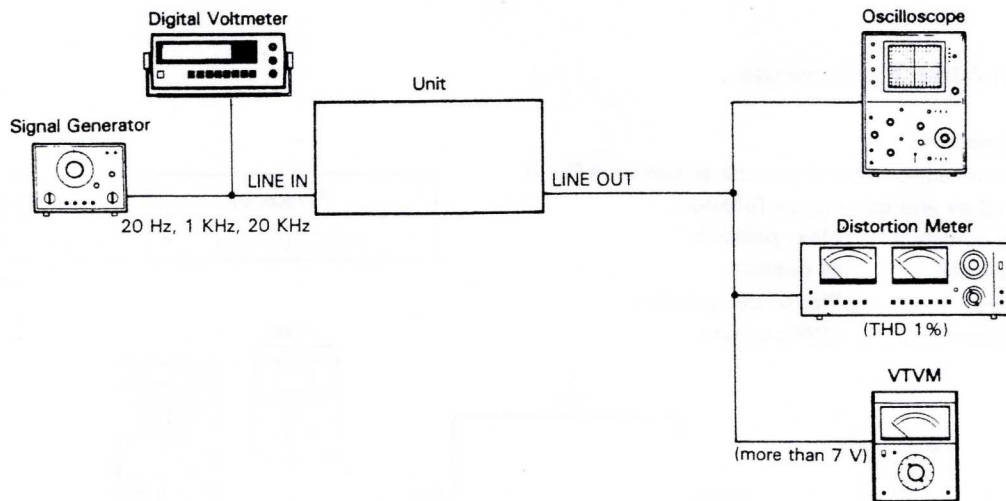

Fig. 5

ADJUSTMENT PROCEDURE

● Center frequency of each BAND

1. Connect the test equipment to the unit as shown in fig. 6.
2. Set the switches and controls as follows
 ATT enuator control.....Max. position
 EQ IN/OUT switchIN position
 EQ slide leversFlat (0 dB) position
 LINE/MIC selector.....LINE position
3. Move each slide levers form 0 dB to +15 dB position severally.
4. Tune audio signal generator frequency for max. output voltage is obtained at LINE OUT

Center freq.	Deflection	Tolerance
31.5 Hz	± 10%	28.4 ~ 34.7 Hz
63 Hz	± 10%	56.7 ~ 69.3 Hz
125 Hz	± 10%	113 ~ 138 Hz
250 Hz	± 10%	225 ~ 275 Hz
500 Hz	± 10%	450 ~ 550 Hz
1 kHz	± 10%	0.9 ~ 1.1 kHz
2 kHz	± 10%	1.8 ~ 2.2 KHz
4 KHz	± 10%	3.6 ~ 4.4 KHz
8 KHz	± 10%	7.2 ~ 8.8 KHz
16 KHz	± 10%	14.4 ~ 17.6 KHz

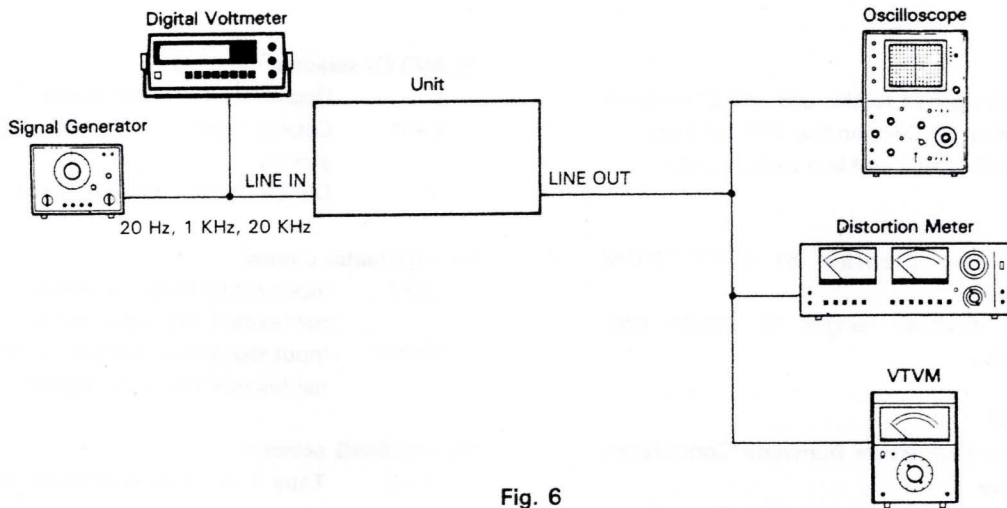

Fig. 6

● Graphic EQ control response

1. Connect the test equipment to the unit as shown in fig. 7.
2. Set the switches and controls as follows.
 ATT enuator contro...Max. position
 EQ IN/OUT switchIN position
 EQ slide lever.....Flat (0 dB) position
 LINE/MIC selector.....LINE position
3. Apply 1 kHz 300 mV to LINE IN terminals.(LINE OUT voltage is 267 ~ 336mV)

4. Set audio signal generator to 31.5 Hz, EQ slide lever of 31.5 Hz to maximum +15 dB position. Read a LINE OUT voltage (1503 ~ 1787mV). Change the EQ slide lever to minimum (-15 dB) position and measure the LINE OUT voltage (47.5 ~ 56.5 mV).
5. Measure the following 63,125,250,500, 1 K, 2 K, 4 K, 8 K, 16 K Hz, similary on the above mentioned.

maximum (+15 dB) position	1503 ~ 1787 mV
Flat (0 dB) position	267 ~ 336 mV
Minimum(-15 dB) position	47.5 ~ 56.5 mV

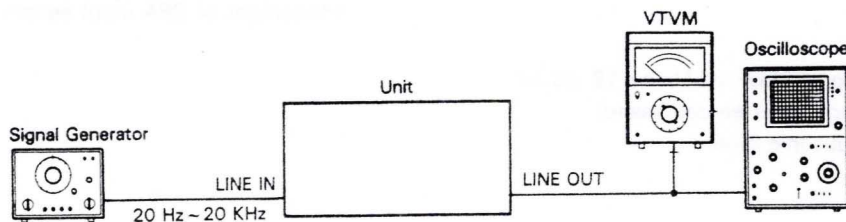

Fig. 7

ADJUSTMENT PROCEDURE

CONTROLS AND FUNCTIONS

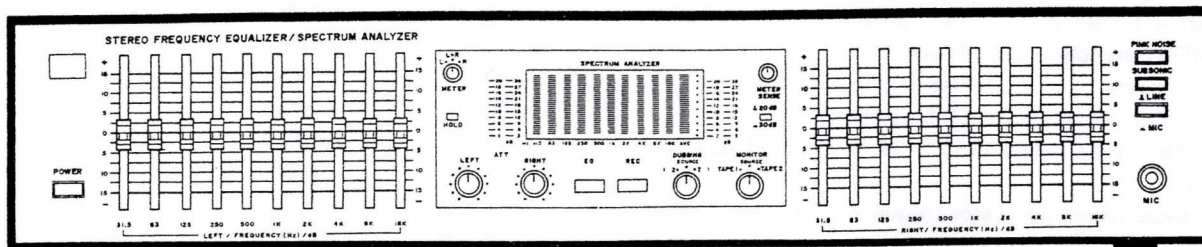
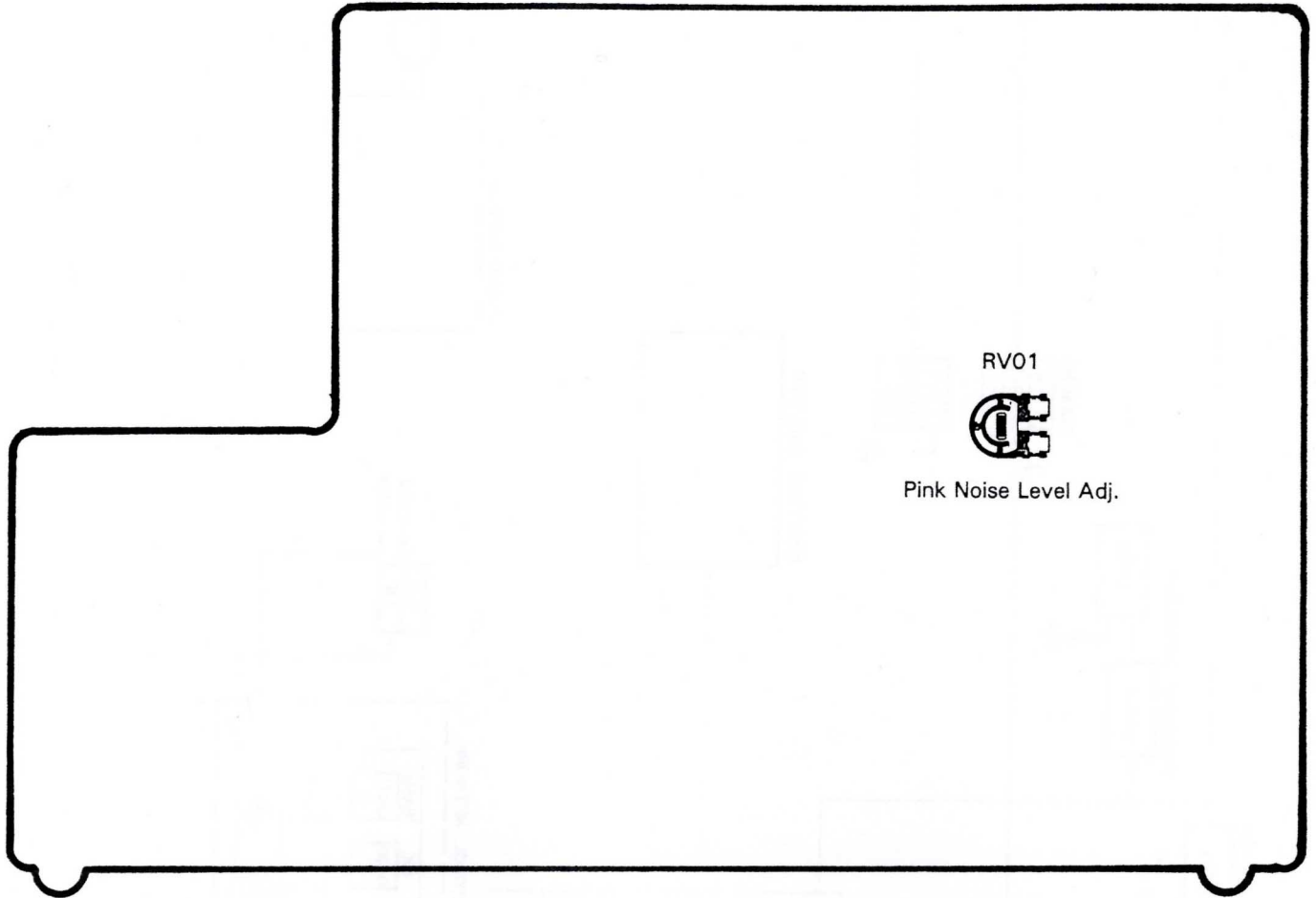

Fig. 8

- 1) **POWER switch**
 Depress Power is applied to the unit 'ADC' emblem illuminates 20 Dots on the SPA light up.
 Release Power off 'ADC' emblem extinguishes
- 2) **HOLD switch**
 Depress Holds the display of SPECTRUM ANALYZER.
 Release Shows dynamic ranges of inputs continuously.
- 3) **EQ IN/OUT switch**
 Depress LEDs on slide levers illuminate Controls are operative
 Release LEDs on slide levers extinguish Controls are inoperative
- 4) **REC IN/OUT switch**
 Depress Frequency equalized tape recording or dubbing (the EQ switch must be depressed)
 Release Recording without frequency equalized
- 5) **20/30 dB switch**
 Depress 30dB dynamic range SPA
 Release 20dB dynamic range SPA
- 6) **LINE/MIC selector**
 Depress Display a MIC input level
 Release Display a LINE input level
- 7) **SUBSONIC filter switch**
 Depress Attenuates signal below 15 Hz by 18 dB/octave (EQ switch must be depressed)
 Release Inoperative subsonic filter
- 8) **PINK NOISE switch**
 Depress Pink noise signal is provided to left and right channel LINE OUT . Pink noise signal is displayed on the SPA.
 Release Pink noise signal is stopped to generate
- 9) **METER selector**
 L Display LEFT channel signal
 L + R Display both LEFT and RIGHT channel signals
 R Display RIGHT channel signal
- 10) **Attenuator control**
 LEFT Input signal level adjustment of LEFT channel (except Mic input signal)
 RIGHT Input signal level adjustment of RIGHT channel (except Mic input signal)
- 11) **DUBBING selector**
 1 > 2 Tape 1 program is provided to Tape 2 output
 SOURCE LINE IN signal is provided to Tape 1 and Tape 2 outputs
 2 > 1 Tape 2 program is provided to Tape 1 output
- 12) **MONITOR selector**
 TAPE 1 Tape 1 program is obtained on LINE OUT terminal
 SOURCE Signals from LINE IN is obtained on LINE OUT terminal
 TAPE 2 Tape 2 program is obtained on LINE OUT terminal
- 13) **METER SENSE control**
 Adjustment of SPA input sensitivity

ADJUSTMENT POINTS

APSAB041AD



RV01



Pink Noise Level Adj.

APSDS018AD

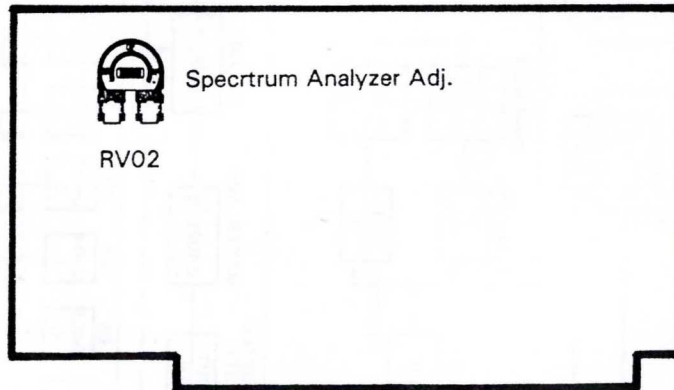

Spectrum Analyzer Adj.

RV02

BLOCK DIAGRAM

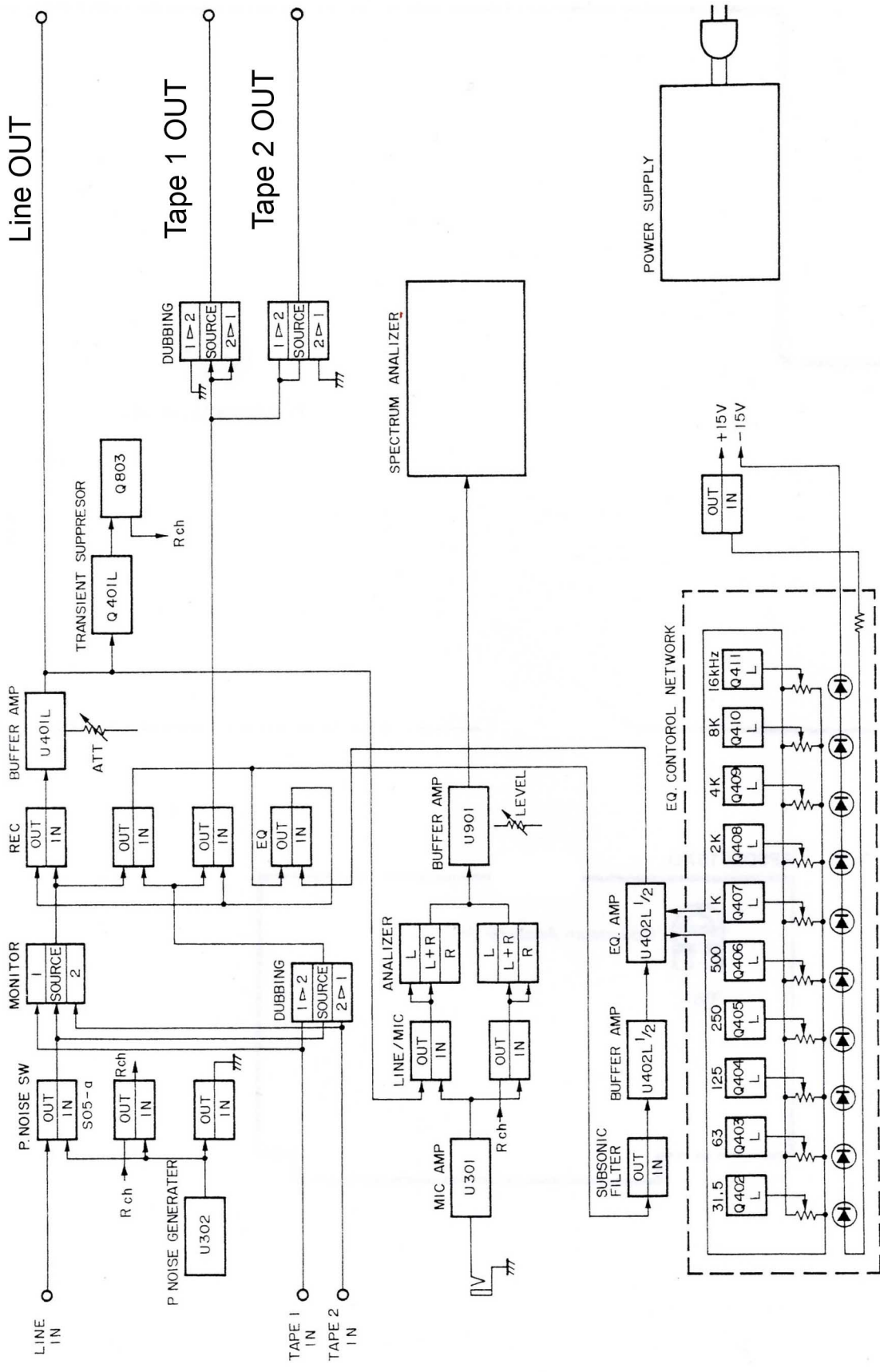

BLOCK DIAGRAM

SPECTRUM ANALYZER

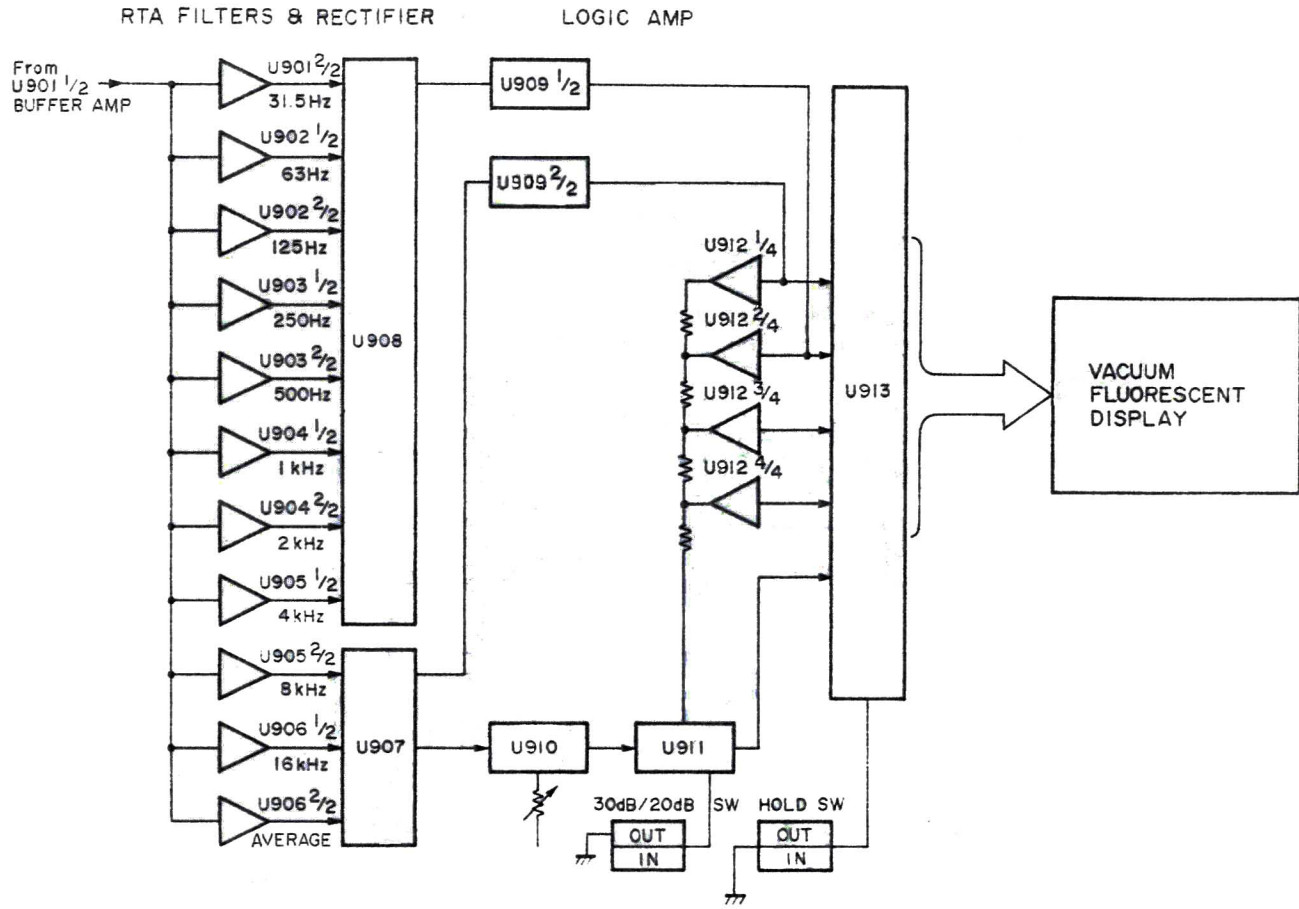

POWER SUPPLY

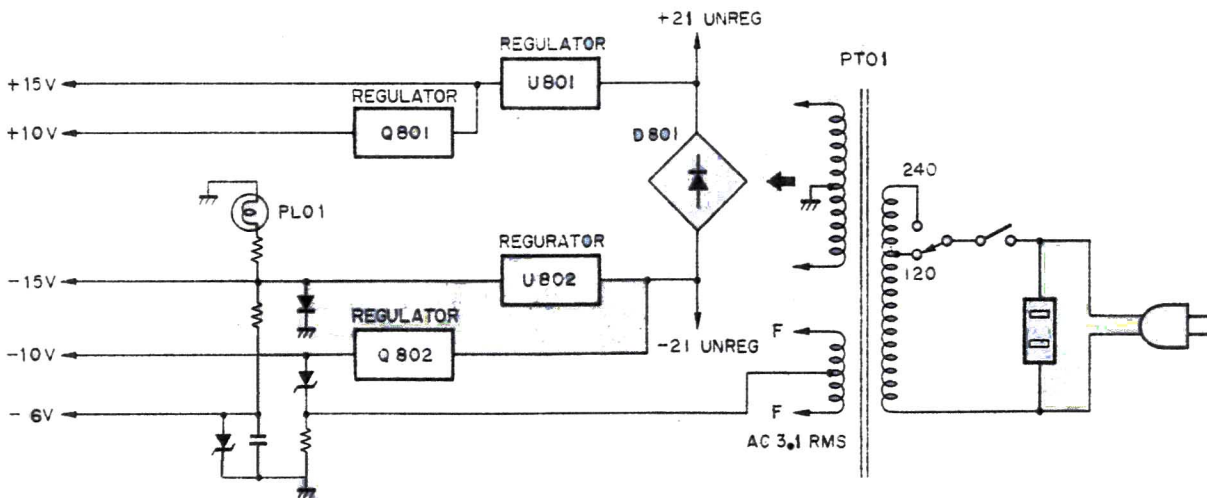

WIRING BOARD LAYOUT

Foil side view

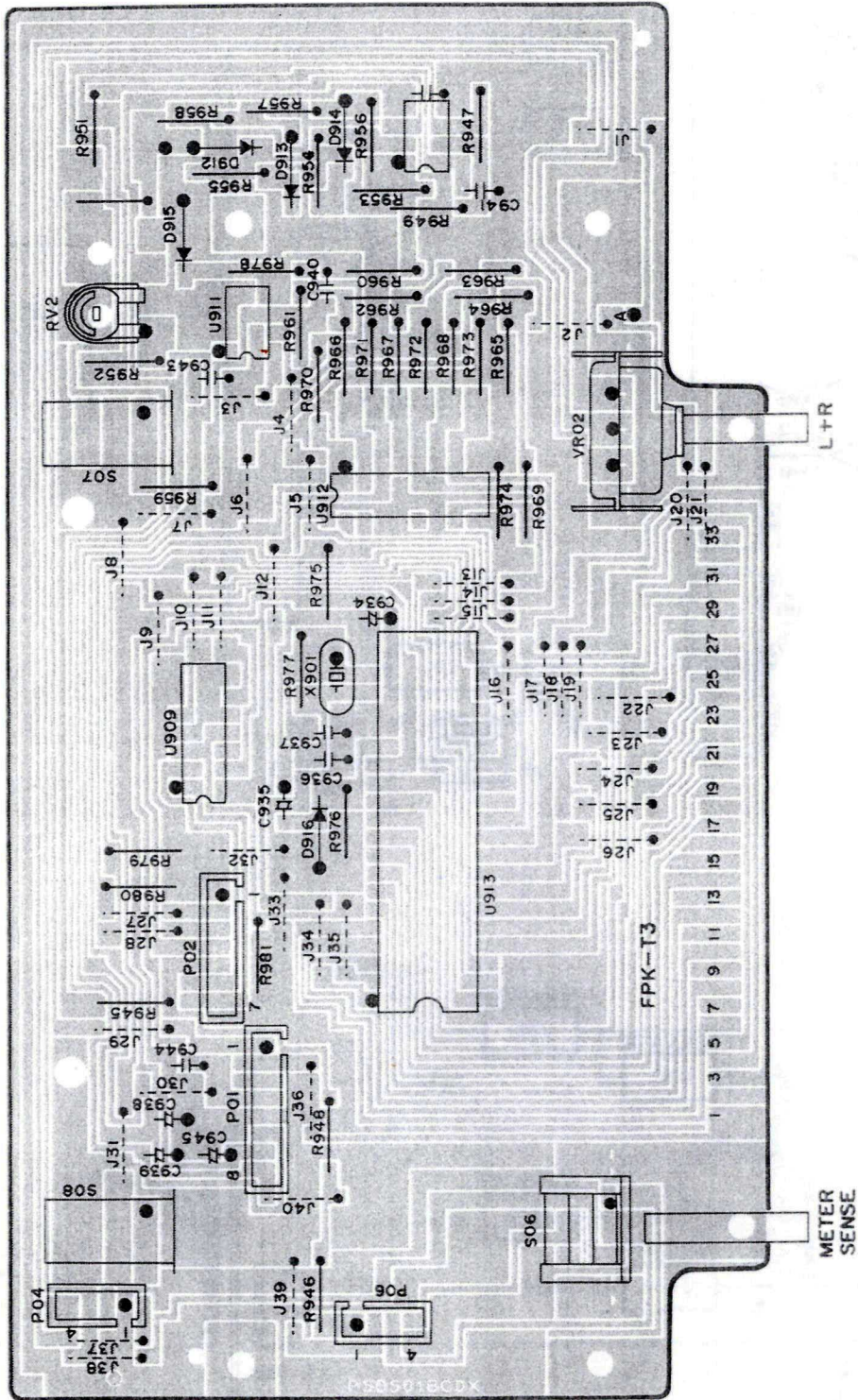

APSDS018AD (AP-2)
 (See page 19, 20)

WIRING LAYOUT

Parts marked with * vary according to destinations. For details, refer to the part list.

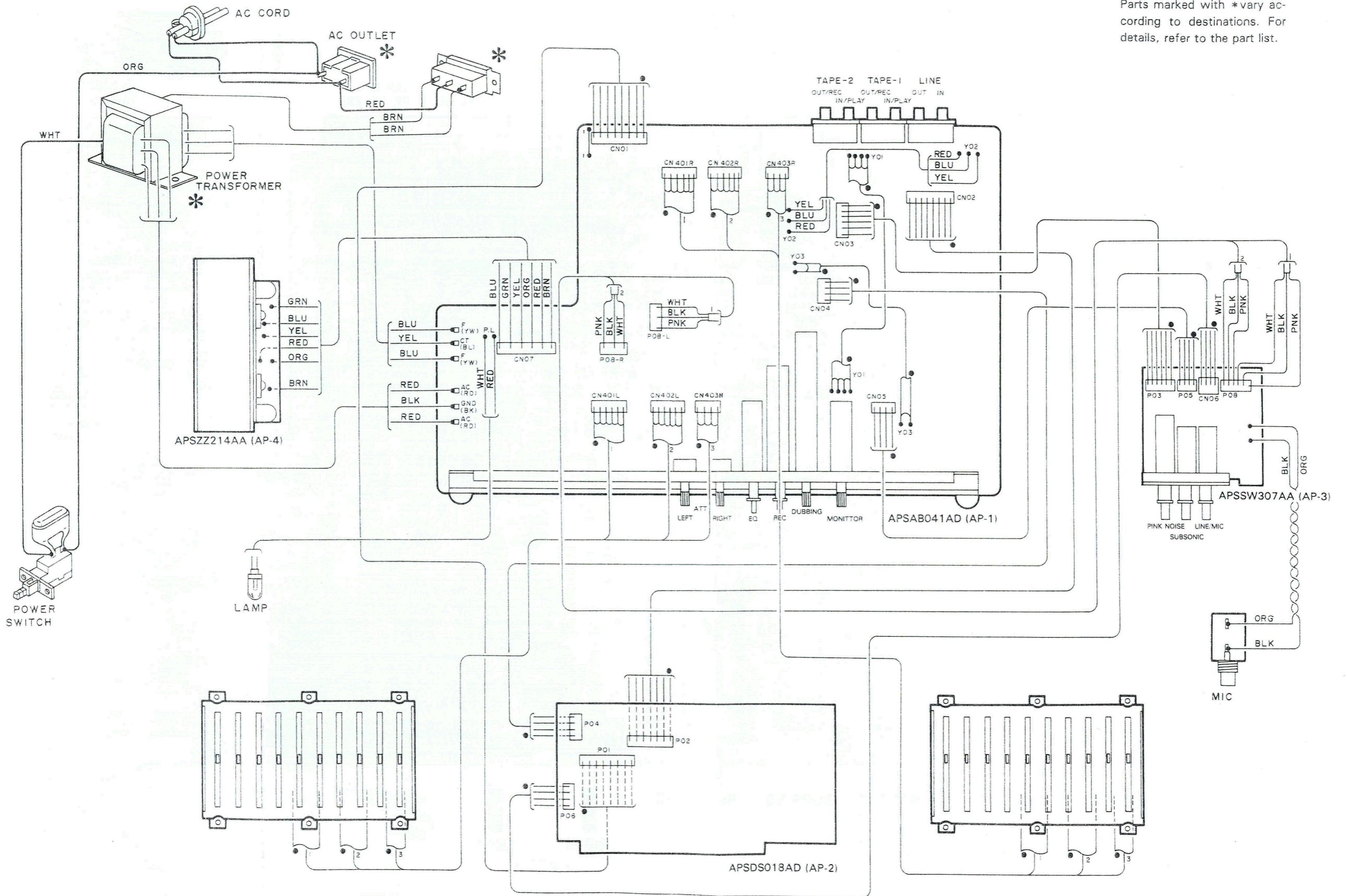

SCHEMATIC DIAGRAM

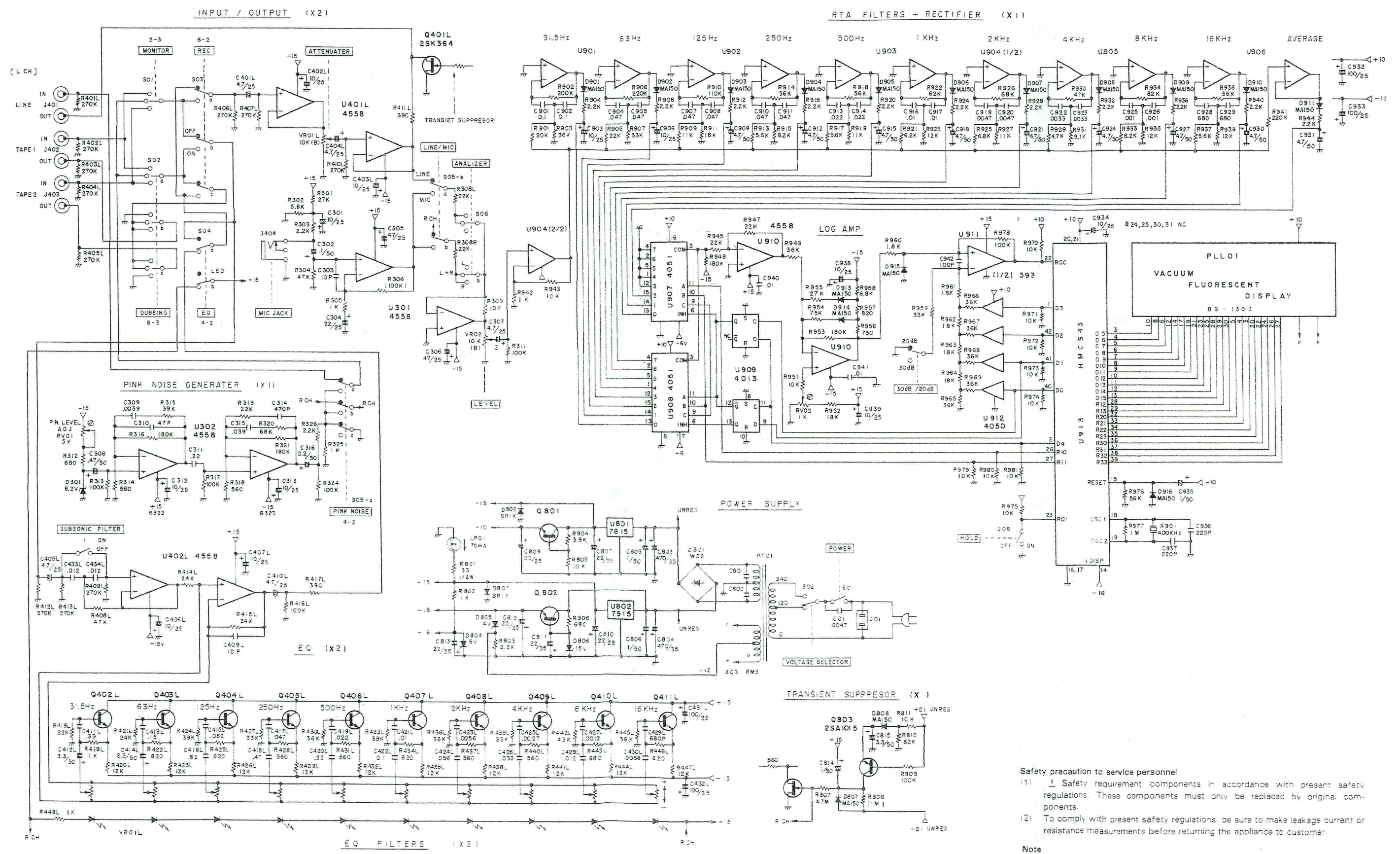

Safety precaution to service personnel!

- (1) Safety requirement components in accordance with present safety regulations. These components must only be replaced by original components.
- (2) To comply with present safety regulations, be sure to make leakage current or resistance measurements before returning the appliance to customer.

Note
 All resistors are 1/4 watt unless otherwise noted.
 Resistor values are in ohm (1K = 1000 ohm).
 All capacitor values are in micro-farad (p = pico-farad)

EXPLODED VIEW

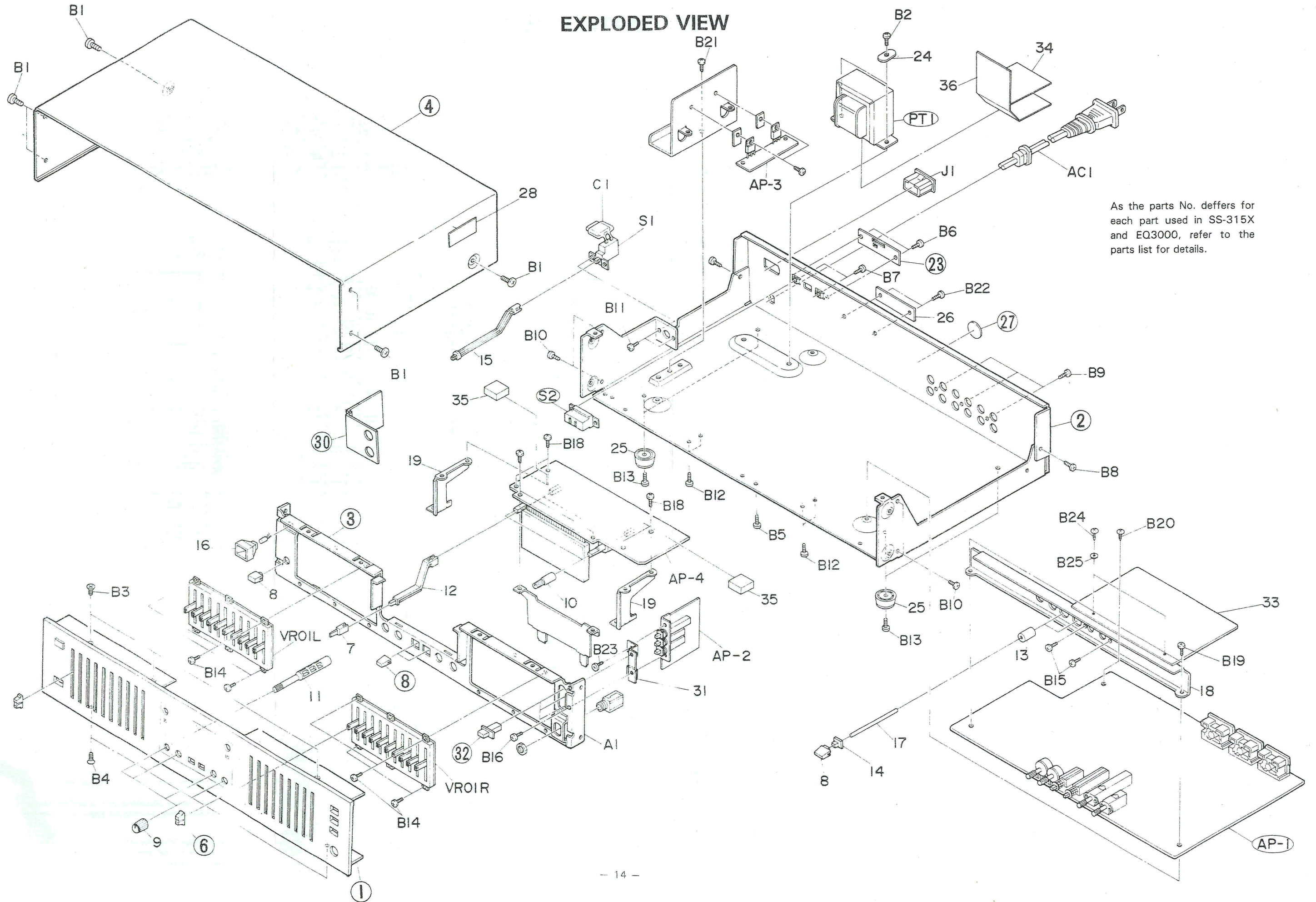

As the parts No. differs for each part used in SS-315X and EQ3000, refer to the parts list for details.

IC BLOCK DIAGRAM

HD38755AB

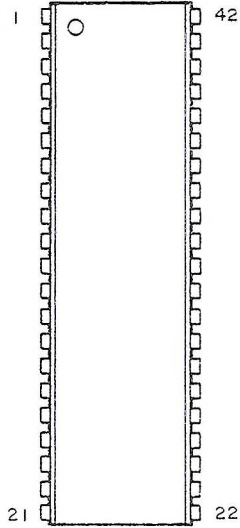

Pin No.	Terminal Name	Pin No.	Terminal Name
1	D3	22	R00
2	D4	23	R01
3	D5	24	R02
4	D6	25	R03
5	D7	26	R10
6	D8	27	R11
7	D9	28	R12
8	D10	29	R13
9	D11	30	INT0
10	D12	31	INT1
11	D13	32	R20
12	D14	33	R21
13	D15	34	R22
14	V _{DISP}	35	R23
15	RESET	36	R30
16	V _{BB}	37	R31
17	V _{DD}	38	R32
18	OSC ₁	39	R33
19	OSC ₂	40	D0
20	TEST	41	D1
21	V _{SS}	42	D2

4050

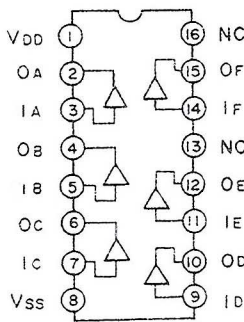

4051

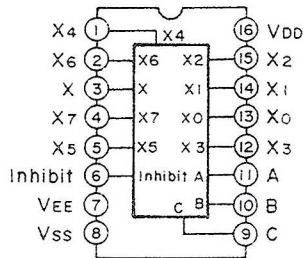

4013

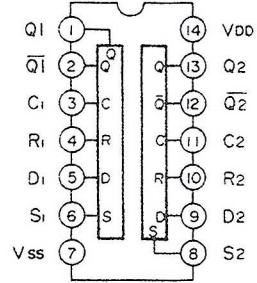

4558

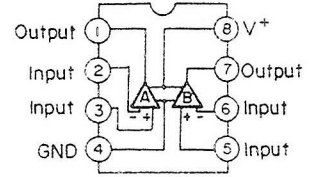

7915

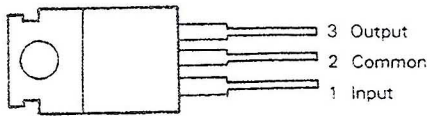

7815

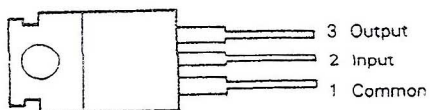

LM393

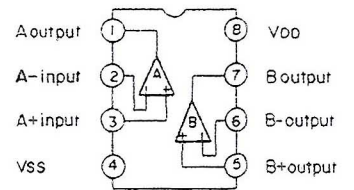

REPLACEMENT PART LIST

SS-315X

TABLE OF PART STRUCTURE

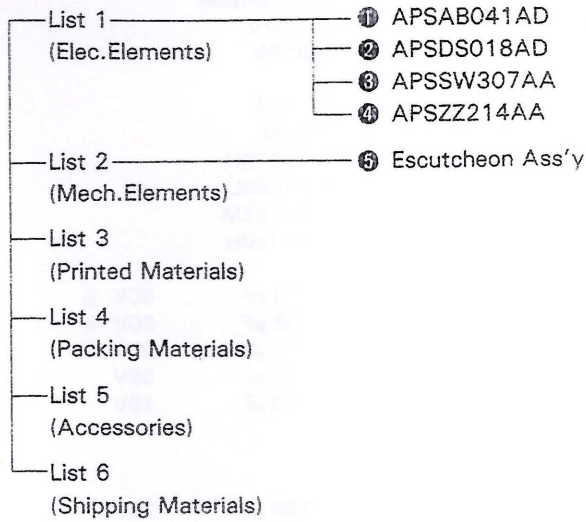

List 1. ELEC. ELEMENTS

U = USA version PX = PX version

Ref. No.	BSR/ADC Part No.	MFR's P/N	Description
AP1 ①		APSAB014AD	P.W.Board Ass'y
AP4 ②		APSDS018AD	P.W.Board Ass'y
AP2 ③		APSSW307AA	P.W.Board Ass'y
AP3 ④		APSZZ214AA	P.W.Board Ass'y
PT1		TPL60V002T	Power Transformer (PX)
*		TPL60V002T	* (U)
AC1		ACAC029ULA	AC Cord (PX)
*		ACAC029ULA	* (U)
ACB1		VM270NB001	Bushing (PX)
*		VM270NB001	* (U)
C1		CKDU102KBM	Ceramic 1000 pF 125V K B (PX)
*		CKDU102KBM	* 1000 pF 125V (U)
VR01L		RS0LC54G02	Slide VR 50 K-G
VR01R		RS0LC54G03	Slide VR 50 K-G
S1		SP01AAW02A	Push Switch
S2		SS010226AJ	Slide Switch (PX only)
ZZ1		VX421VL001	C.Cover
J1		YJA02S007U	AC Jack S2-723B-50

① APSAB041AD (P.W.Board Ass'y)

Ref. No.	BSR/ADC Part No.	MFR's P/N	Description
U301,302 401L/R,402L/R 901 - 906 U907,908		QQM04558A&	IC 4558 (IR94558)
Q803 Q802 Q402L/R,403L/R 404L/R,405L/R 406L/R,407L/R 408L/R,409L/R 410L/R,411L/R		QQ004051A& QTA1015XAT QTB0511XAC QTC2634XAN	IC 4051 (HD14051B) Transistor 2SA1015 (Y,GR) Transistor 2SB511(D,E) Transistor 2SC2634(S,T)

REPLACEMENT PART LIST

SS-315X

Ref. No.	BSR/ADC Part No.	MFR's P/N	Description		
Q801		QTD0325XCC	Transistor	2SD325(D,E)	
401L/R		QTK0170XAT	FET	2SK170	
D807,808, 901~911		QDSMA150XN	Diode	MA150	
D802,803		QDSSR1KX4P	Diode	SR1K-4	
D801		QDSW02MXXG	Diode	W02M	
D805		QDZA1039HN	Diode Zener	MA1039H	
D804		QDZA1062LN	Diode Zener	MA1062L	
D301		QDZA1082MN	Diode Zener	MA1082M	
D806		QDZA1160HN	Diode Zener	MA1160H	
C303		CCGB100D0T	Ceramic	10 pF	50V D
C409L/R		CCGB680K0T	Ceramic	68 pF	50V K
C404L/R		CEAE4R7ZMN	Electrolytic	4.7 μ F	25V M
C803,804		CEAF471ALX	Electrolytic	470 μ F	35V
C301,312,313, 402,403,406, 407,903 435L/R,906		CEVE100ALX	Electrolytic	10 μ F	25V
C431L/R,432L/R 932,933		CEVE101ALX	Electrolytic	100 μ F	25V
C304,436,809, 811,812,813		CEVE220ALX	Electrolytic	22 μ F	25V
C307,909,912, 915,918,921, 924,927,930, 931		CEVE4R7ALX	Electrolytic	4.7 μ F	25V
C401L/R,405L/R 410L/R		CEVE4R7NLX	Electrolytic	4.7 μ F	25V
C305,306		CEVE470ALX	Electrolytic	47 μ F	25V
C308		CEVGR47ALX	Electrolytic	0.47 μ F	50V
C302,814		CEVG010ALX	Electrolytic	1 μ F	50V
C316,414L/R		CEVG2R2ALX	Electrolytic	2.2 μ F	50V
C412L/R,815		CEVG3R3ALX	Electrolytic	3.3 μ F	50V
C801,802		CKFB103MDT	Ceramic	0.01 μ F	50V M D
C310		CQSC470JEB	Styrol	47 pF	100V J
C422L/R,901,902		CQVB104JTN	Mylar	0.1 μ F	50V J
C433L/R,434L/R		CQVB124JSN	Mylar	0.12 μ F	50V J
C413L/R		CQVB154JTN	Mylar	0.15 μ F	50V J
C420L/R		CQVB224JSN	Mylar	0.22 μ F	50V J
C408L/R		CQVB224JTN	Mylar	0.22 μ F	50V J
C426L/R		CQVB333JTN	Mylar	0.033 μ F	50V J
C411L/R		CQVB334JTN	Mylar	0.33 μ F	50V J
C315		CQVB393JTN	Mylar	0.039 μ F	50V J
C417L/R,904, 905,907,908 910,911		QVB473JTN	Mylar	0.047 μ F	50V J
C418L/R		CQVB474JSN	Mylar	0.47 μ F	50V J
C424L/R		CQVB563JTN	Mylar	0.056 μ F	50V J
C415L/R		CQVB823JTN	Mylar	0.082 μ F	50V J
C416L/R		CQVB824JSN	Mylar	0.82 μ F	50V J
C311		CQ4B224KEH	Mylar	0.22 μ F	50V J
C314		CQ4B471JTH	Mylar	470 pF	50V J
C429L/R,928,929		CQ4B681JTH	Mylar	680 pF	50V J
C925,926		CQ8B102JTN	Mylar	1000 pF	50V J
C421L/R,916,917		CQ8B103JTN	Mylar	0.01 μ F	50V J
C427L/R		CQ8B122JTN	Mylar	1200 pF	50V J
C428L/R		CQ8B123JTN	Mylar	0.012 μ F	50V J
C419L/R,413,914		CQ8B223JTN	Mylar	0.022 μ F	50V
C425L/R		CQ8B272JTN	Mylar	2700 pF	50V
C922,923		CQ8B332JTN	Mylar	3300 pF	50V

REPLACEMENT PART LIST

SS-315X

Ref. No.	BSR/ADC Part No.	MFR's P/N	Description		
C309		CQ8B392JTN	Mylar	3900 pF	50V
C919,920		CQ8B472JTN	Mylar	4700 pF	50V
C423L/R		CQ8B562JTN	Mylar	5600 pF	50V
C430L/R		CQ8B682JTN	Mylar	5600 pF	50V
R305,325,419L/R 448L/R,802,942		RD25PJ102X	Carbon	1/4W	1 K ohm 5%
R309,805,811 943		RD25PJ103X	Carbon	1/4W	10 K ohm 5%
R306,311,313 317,324 416L/R,809		RD25PJ104X	Carbon	1/4W	100 K ohm 5%
R808		RD25PJ105X	Carbon	1/4W	1 M ohm 5%
R909,919,927		RD25PJ113X	Carbon	1/4W	11 K ohm 5%
R910		RD25PJ114X	Carbon	1/4W	110 K ohm 5%
R326		RD25PJ122X	Carbon	1/4W	1.2 K ohm 5%
R414L/R,415L/R 420L/R,423L/R 426L/R,429L/R 432L/R,435L/R 438L/R,441L/R 444L/R,447L/R 923,935,939		RD25PJ123X	Carbon	1/4W	12 K ohm 5%
R911		RD25PJ183X	Carbon	1/4W	18 K ohm 5%
R316,321		RD25PJ184X	Carbon	1/4W	180 K ohm 5%
R901		RD25PJ203X	Carbon	1/4W	20 K ohm 5%
R902		RD25PJ204X	Carbon	1/4W	200 K ohm 5%
R303,803,904, 908,912,916 920,924,928 932,936,940 944		RD25PJ222X	Carbon	1/4W	2.2 K ohm 5%
R319,418L/R,905		RD25PJ223X	Carbon	1/4W	22 K ohm 5%
R906,941		RD25PJ224X	Carbon	1/4W	220 K ohm 5%
R421L/R		RD25PJ244X	Carbon	1/4W	24 K ohm 5%
R301		RD25PJ273X	Carbon	1/4W	27 K ohm 5%
R401L/R,402L/R 403L/R,404L/R 405L/R,406L/R 407L/R,409L/R 410L/R,412L/R 413L/R		RD25PJ274X	Carbon	1/4W	270 K ohm 5%
R450		RD25PJ331X	Carbon	1/4W	330 ohm 5%
R427L/R,439L/R 907		RD25PJ333X	Carbon	1/4W	33 K ohm 5%
R430L/R,436L/R 445L/R,903		RD25PJ363X	Carbon	1/4W	36 K ohm 5%
R411L/R,417L/R		RD25PJ391X	Carbon	1/4W	390 ohm 5%
R804		RD25PJ392X	Carbon	1/4W	3.9 K ohm 5%
R315,424L/R 433L/R		RD25PJ393X	Carbon	1/4W	39 K ohm 5%
R442L/R		RD25PJ433X	Carbon	1/4W	43 K ohm 5%
R929		RD25PJ472X	Carbon	1/4W	4.7 K ohm 5%
R304,408L/R 449L/R,930		RD25PJ473X	Carbon	1/4W	47 K ohm 5%
R314,318,428L/R 431L/R,437L/R 440L/R		RD25PJ561X	Carbon	1/4W	560 ohm 5%
R302,913,917 937		RD25PJ562X	Carbon	1/4W	5.6 K ohm 5%
R914,918,938		RD25PJ563X	Carbon	1/4W	56 K ohm 5%
R425L/R,434L/R 446L/R		RD25PJ621X	Carbon	1/4W	620 ohm 5%

REPLACEMENT PART LIST

SS-315X

Ref. No.	BSR/ADC Part No.	MFR's P/N	Description			
R921		RD25PJ622X	Carbon	1/4W	6.2 K ohm	5%
R922		RD25PJ623X	Carbon	1/4W	62 K ohm	5%
R312,443L/R,806		RD25PJ681X	Carbon	1/4W	680 ohm	5%
R925		RD25PJ682X	Carbon	1/4W	6.8 K ohm	5%
R320,926		RD25PJ683X	Carbon	1/4W	68 K ohm	5%
R422L/R		RD25PJ821X	Carbon	1/4W	820 ohm	5%
R915,933		RD25PJ822X	Carbon	1/4W	8.2 K ohm	5%
R810,934		RD25PJ823X	Carbon	1/4W	82 K ohm	5%
R931		RD25PJ912X	Carbon	1/4W	9.1 K ohm	5%
R801		RG2ARJ221B	Metal Oxid	2W	220 ohm	
R807		RQBCG4704X	Metal Oxide	1/4W	4.70 M ohm	
RV01		RPGNB50201	Semi Fixed		5 K-B	
VR01L/R		RVNA103B32	Volume		10 K-B	
S01		SH040310ZA	Rotary Slide Switch	SRZS043N		
S02		SH060305ZA	Rotary Slide Switch	SRZS063N		
S03		SP01AAX92D	Push Switch	PSC00-C6K		
S04		S001AAX93D	Push Switch	PSC00-C4K		
CN08L/R		YJF03S042Z	Connector	B3B-XH-A		
CN04,CN05		YJF04S043Z	Connector	B4B-XH-A		
CN403L/R		YJF04S100U	Connector	W-D 0604		
CN03,CN07		YJF06S035Z	Connector	B6B-XH-A		
CN401L/R,402L/R		YJF06S100U	Connector	W-D 0606		
CN02		YJF07S018Z	Connector	B7B-XH-A		
CN01		YJF08S028Z	Connector	B8B-XH-A		
J401 ~ 403		YJP04S023U	4P Jack			
LP01		ZPA148107U	Lamp		14V 80mA	

② APSDS018AD (P.W.Board Ass'y)

Ref. No.	BSR/ADC Part No.	MFR's P/N	Description			
U911		QQM00393A&	IC	393	(NJM2903D)	
U910		QQM04558A&	IC	4558	(IR94558)	
U913		QQP38755AB	IC	HD38755AB		
U909		QQ004013A&	IC	4013		
U912		QQ004050A&	IC	4050		
D912 ~ 916		QDSMA150XN	Diode	MA150		
X901		CX0400005T	Ceramic OSC		400 kHz	
C942		CCGB101J0T	Ceramic	100 pF	50V	J
C936,937		CCGB221K0T	Ceramic	220 pF	50V	K
C934		CEAD471ALX	Electrolytic	470 μ F	16V	
C938,939		CEVE100ALX	Electrolytic	10 μ F	25V	
C935		CEVG010ALX	Electrolytic	1 μ F	50V	
C940,941		CKFB103ZFT	Ceramic	0.01 μ F	50V	
R951,970 ~ 975 979,980,981		RD25PJ103X	Carbon	1/4W	10 K ohm	5%
R978		RD25PJ104X	Carbon	1/4W	100 K ohm	5%
R977		RD25PJ105X	Carbon	1/4W	1 M ohm	5%
R960,961		RD25PJ182X	Carbon	1/4W	1.8 K ohm	5%
R952,962 ~ 964		RD25PJ183X	Carbon	1/4W	18 K ohm	5%
R948,953		RD25PJ184X	Carbon	1/4W	180 K ohm	5%
R945,947		RD25PJ223X	Carbon	1/4W	22 K ohm	5%
R955		RD25PJ273X	Carbon	1/4W	27 K ohm	5%
R959		RD25PJ333X	Carbon	1/4W	33 K ohm	5%
R949,965-969		RD25PJ363X	Carbon	1/4W	36 K ohm	5%
R976		RD25PJ563X	Carbon	1/4W	56 K ohm	5%
R958		RD25PJ682X	Carbon	1/4W	6.8 K ohm	5%

REPLACEMENT PART LIST

SS-315X

Ref. No.	BSR/ADC Part No.	MFR's P/N	Description		
R956		RD25PJ751X	Carbon	1/4W	750 ohm 5%
R954		RD25PJ753X	Carbon	1/4W	75 K ohm 5%
R957		RD25PJ821X	Carbon	1/4W	820 ohm 5%
RV02		RPGNB10201	Semi Fixed		1 K-B
VR02		RVNA103B33	Semi Fixed		10 K-B
S06		SR0203108H	Rotary Switch	SRU1023S	
S07,S08		SP01AAX94D	Push Switch	PSC00-A2K	
PLL01		ZLBG130ZX7	Display Tube	BG130Z	
20		MS757SL002	FL Tube Bracket		
21		MU222SL001	Switch Bracket		
22		VS637RF001	FL Tube Cushion		
B17		BSPB3006NZ	Screw	M3×6	

③ APSSW307AA (P.W.Board Ass'y)

Ref. No.	BSR/ADC Part No.	MFR's P/N	Description		
C437L/R		PSSW307COX	P.W.Board		
R308L/R		CEVGR47ZMN	Electrolytic	0.47 μF	50V M
R451L/R		RD25PJ223X	Carbon	1/4W	22 K ohm 5%
S05		RD25PJ225X	Carbon	1/4W	2.2 M ohm 5%
CN06		SPO3FAX08D	Push Switch		
J404		YJF04S043Z	Connector	B4B-XH-A	
		YJS03S026Z	Phone Jack	HLJ4308-01-100	

① APSZZ214AA (P.W.Board Ass'y)

Ref. No.	BSR/ADC Part No.	MFR's P/N	Description		
U801		PSZZ214COX	P.W.Board		
U802		QQM07815BJ	IC	NJM7815A	
C807,810		QQM07915EJ	IC	NJM7915A	
C805,806		CEVE220ALX	Electrolytic	22 μF	25V
HS01		CEVG010ALX	Electrolytic	1 μF	50V
		MU566AD001	Heat Sink		
		VF164DN003	Bushing		
		VS223RH002	Silicon Sheet		

List 2. MECH. ELEMENTS

Ref. No.	BSR/ADC Part No.	MFR's P/N	Description		
① ⑤		AMSS3150X1	Escutcheon Ass'y		
②		MB986SK021	Chassis		
③		MB962SK018	Front Panel		
④		MU796SX001	Cover		
⑥		VN120SB026	Slide Knob		
7		VN310SB001	Push Button S		
⑧		VN220SP018	Power Button		
9		VN276SB035	Rotary Knob A		
10		VN366SB003	Rotary Knob B		
11		VM666SB001	Volume Joint		
12		VQ611SB006	Switch Joint		
13		VM262RB001	Power Switch Joint		
14		VF111RB002	Button Joint		

REPLACEMENT PART LIST SS-315X

Ref. No.	BSR/ADC Part No.	MFR's P/N	Description
15		VQ611SB002	Shaft
16		VK221RW003	Holder
17		MT533LD001	Shaft Joint
18		MU382SL001	Bracket A
19		MZ662SL003	Bracket B
⑳		MS625AA001	Switch Cover
24		MS317SZ006	Plate
25		VM174SB001	Foot
26		MVSSS11501	Serial No. Plate
28		VVL221WN12	Caution Label
㉑		ML633AA001	Rack Mount Adaptor (PX)
31		MZ511SL001	Switch Bracket
㉒		VK221SP002	Switch Button
33		MS774AX001	Shield
34		VS338FF001	Power Trans. Support
35		VQ221RF004	Cushion
36		ML654SX001	Shield B
B1		BTPB4010TB	Screw M4 x 10
B2		BTPB4008TZ	Screw M4 x 8
B3,4		BTPS3006TB	Screw M3 x 6
B5,6		BTPB3006TB	Screw M3 x 6
B7		BSPB3005NZ	Screw M3 x 5
B8		BTPB3006BZ	Screw M3 x 6
B9		BTPW3008AB	Screw M3 x 8
B10		BTPS3006TZ	Screw M3 x 6
B11,15,23		BSPC3005NZ	Screw M3 x 5
B12		BSPB3006NZ	Screw M3 x 6
B13		BTPB3006TZ	Screw M3 x 6
B14		BTPP3006BZ	Screw M3 x 6
B16		BSPC2605NZ	Screw M2.6 x 5
B18,20		BTPW3006BZ	Screw M3 x 6
B19		BTPW3008BZ	Screw M3 x 8
B21,24		BTPW3005BZ	Screw M3 x 5
B22		BRU2455XAJ	Rivet M2.4 x 5.5
B25		BWK30605SN	Washer M3 x 6 x 0.5

㉓ ESCUTCHEON ASS'Y

Ref. No.	BSR/ADC Part No.	MFR's P/N	Description
1-A		ME96EAA084	Escutcheon
1-B		VS328AK002	Indicator
1-C		VF122SB002	Button Guide
1-D		VS763YB007	VR Sheet
1-E		VS778AS001	FL Plate
1-F		VF142SB002	Button Guide A

List 3. PRINTED MATERIALS

Ref. No.	BSR/ADC Part No.	MFR's P/N	Description
		KTS315XUBX	Owner's Manual (PX)
		KTS315****	* (**)
		KW000327AX	Warranty Card
		KC000414XX	Service Card

REPLACEMENT PART LIST

SS-315X

List 4. PACKING MATERIALS

Ref. No.	BSR/ADC Part No.	MFR's P/N	Description
		KPS315XU01	Inner Carton
		KSS315X01	Outer Carton
		KNSS215*01	Partitioner
		KF243400E4	Polyethylene Bag
		KF506500E6	Polyethylene Bag

List 5. ACCESSORIES

Ref. No.	BSR/ADC Part No.	MFR's P/N	Description
		ZGCZZ20203	Microphone WM-2290
		ACSP023EGA	Stereo Audio Cable

List 6. SHIPPING MATERIALS

Ref. No.	BSR/ADC Part No.	MFR's P/N	Description
		KMS315XP01	Master Carton

REPLACEMENT PART LIST

EQ-3000

• **Note:** The parts not listed should be referred to the parts list for the standard model SS-315X.

List 1. ELEC. ELEMENTS

Ref. No.	BSR/ADC Part No.	MFR's P/N	Description
AP1		APSAB014BD	P.W.Board Ass'y
PT1		TPL57V002T	Power Transformer
S2		Not used	Slide Switch

1 APSAB014BD (P.W.Board Ass'y)

Ref. No.	BSR/ADC Part No.	MFR's P/N	Description
C309		CQ8B392JTN	Mylar 3900 pF 50V J
C310		CQSC470JEB	Styrol 47 pF 100V
C314		CQ4B471JTH	Mylar 470 pF 50V J
C315		CQVB393JTN	Mylar 0.039 μF 50V J
C404L/R		CEAE4R7ZMN	Electrolytic 4.7 μF 25V M
C409L/R		CCGB100D0T	Ceramic 10 pF 50V D
C903		CEVE100ALX	Electrolytic 10 μF 25V
R323		RD25PJ100X	Carbon 1/4W 10 ohm 5%
R325		RD25PJ102X	Carbon 1/4W 1 K ohm 5%
R901		RD25PJ203X	Carbon 1/4W 20 K ohm 5%
R906		RD25PJ224X	Carbon 1/4W 220 K ohm 5%
R910		RD25PJ114X	Carbon 1/4W 110 K ohm 5%
R945,946		Not used	Carbon 1/4W

List 2. MECH. ELEMENTS

Ref. No.	BSR/ADC Part No.	MFR's P/N	Description
1		AM3000XU01	Escutcheon Ass'y
2		MB986SK028	Chassis
3		MB962SL018	Front Panel
4		MU796SX002	Cover
6		VN120SH013	Slide Knob
8		VN220SH006	Power Button
23		Not used	Switch Cover
27		VVL801UL06	UL Mark Label
30		Not used	Rack Mount Adaptor
32		VK221SH001	Switch Button
B7		Not used	Screw M3 × 5

6 ESCUTCHEON ASS'Y

Ref. No.	BSR/ADC Part No.	MFR's P/N	Description
1-A		ME96EAA086	Escutcheon
1-B		VS328AK003	Indicator
1-E		VS778AS002	FL Plate

List 3. PRINTED MATERIALS

Ref. No.	BSR/ADC Part No.	MFR's P/N	Description
		KT3000XUBX	Owner's Manual
		KZ000148AX	Safety Instructions
		Not used	Warranty Card

REPLACEMENT PART LIST

EQ-3000

List 4. PACKING MATERIALS

Ref. No.	BSR/ADC Part No.	MFR's P/N	Description
		KP3000XU01 Not used	Inner Carton Outer Carton

List 6. SHIPPING MATERIALS

Ref. No.	BSR/ADC Part No.	MFR's P/N	Description
		MK3000XU01	Master Carton

GRAPHIC EQUALIZER FREQUENCY RESPONSE

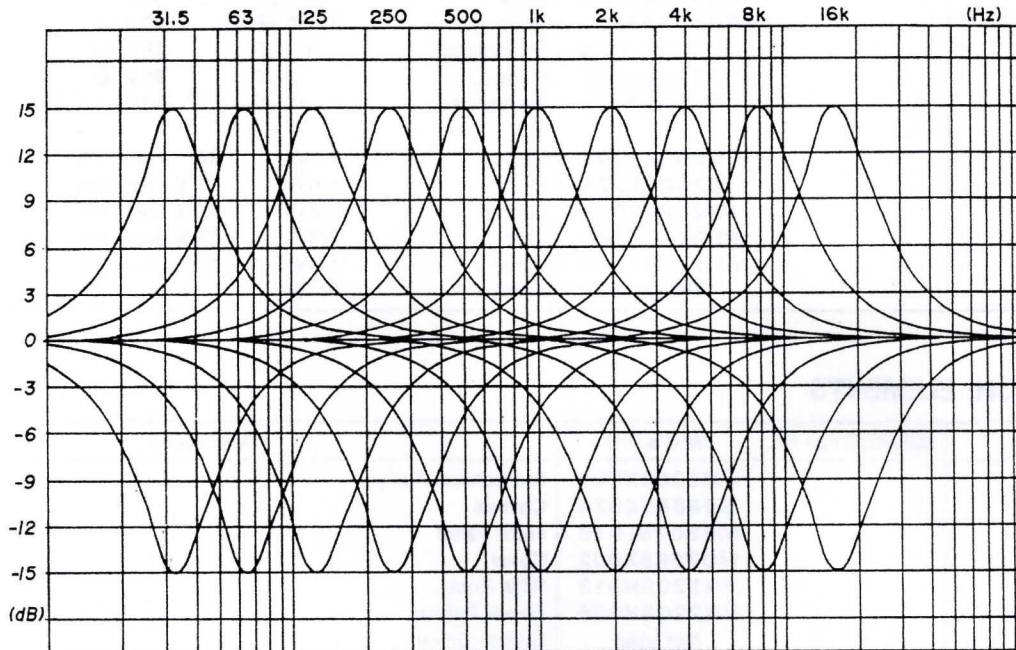

BSR Products
71 Chapel Street
Newton, MA 02195 USA

KDSS315X*X 0185TK

Printed in Japan