

WE SIMPLY SOUND BETTER.

**PT-5**

**SERVICE MANUAL**

B&K COMPONENTS, LTD.  
2100 Old Union Road  
Buffalo, New York 14227-2725  
U.S.A.

**B & K**

WE SIMPLY SOUND BETTER.

# **Schematics**

B&K COMPONENTS, LTD.  
2100 Old Union Road  
Buffalo, New York 14227-2725  
U.S.A.

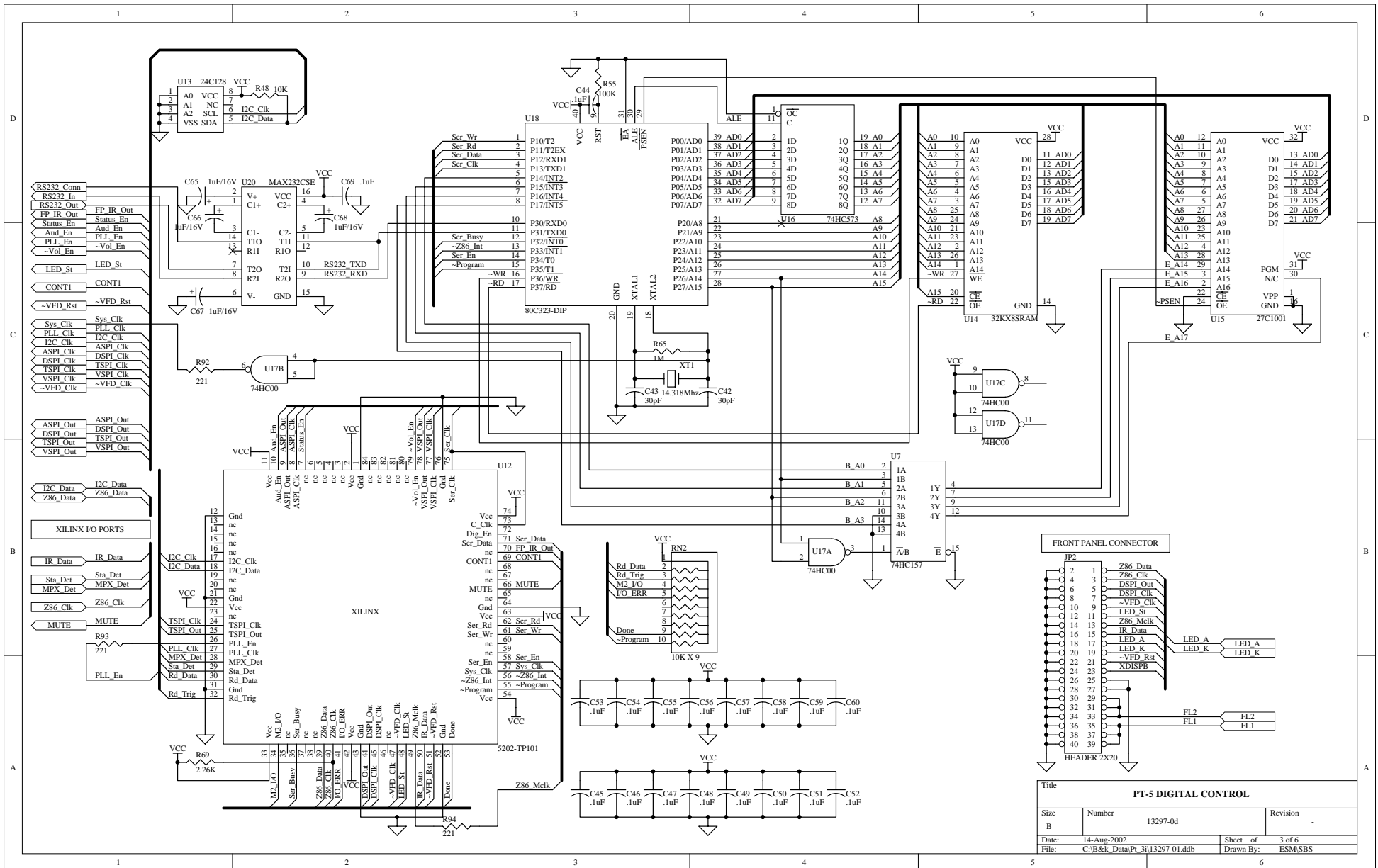

Title			
<b>PT-5 DIGITAL CONTROL</b>			
Size	Number	13297-0d	Revision
B			
Date:	14-Aug-2002	Sheet of	3 of 6
File:	C:\B&k Data\Pl_3\13297-01.ddb	Drawn By:	ESM/SBS

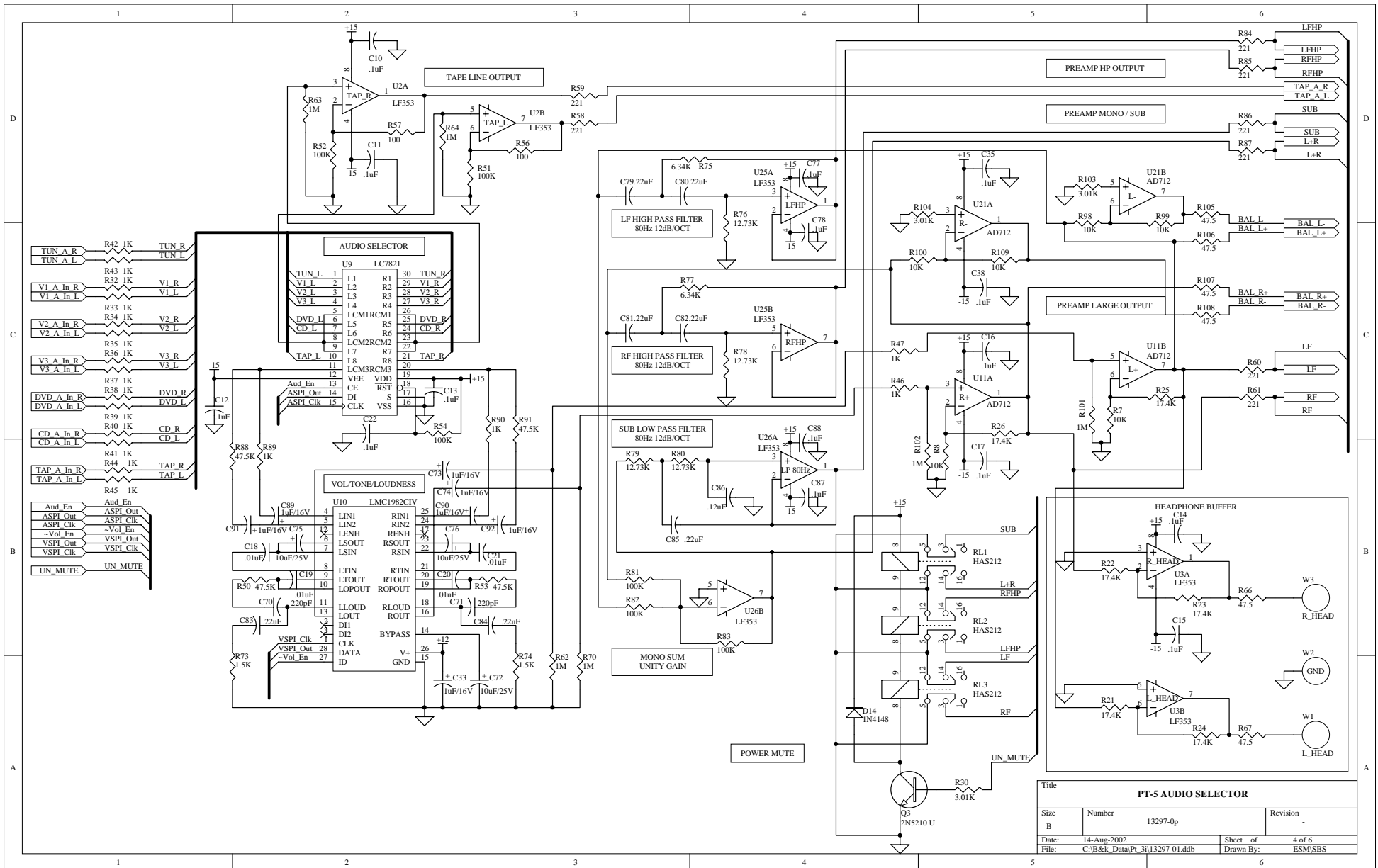

Title			
Size	Number	13297-0p	Revision
B			-
Date:	14-Aug-2002	Sheet of	4 of 6
File:	C:\B&k Data\PI_3\13297-01.ddb	Drawn By:	ESM/SBS

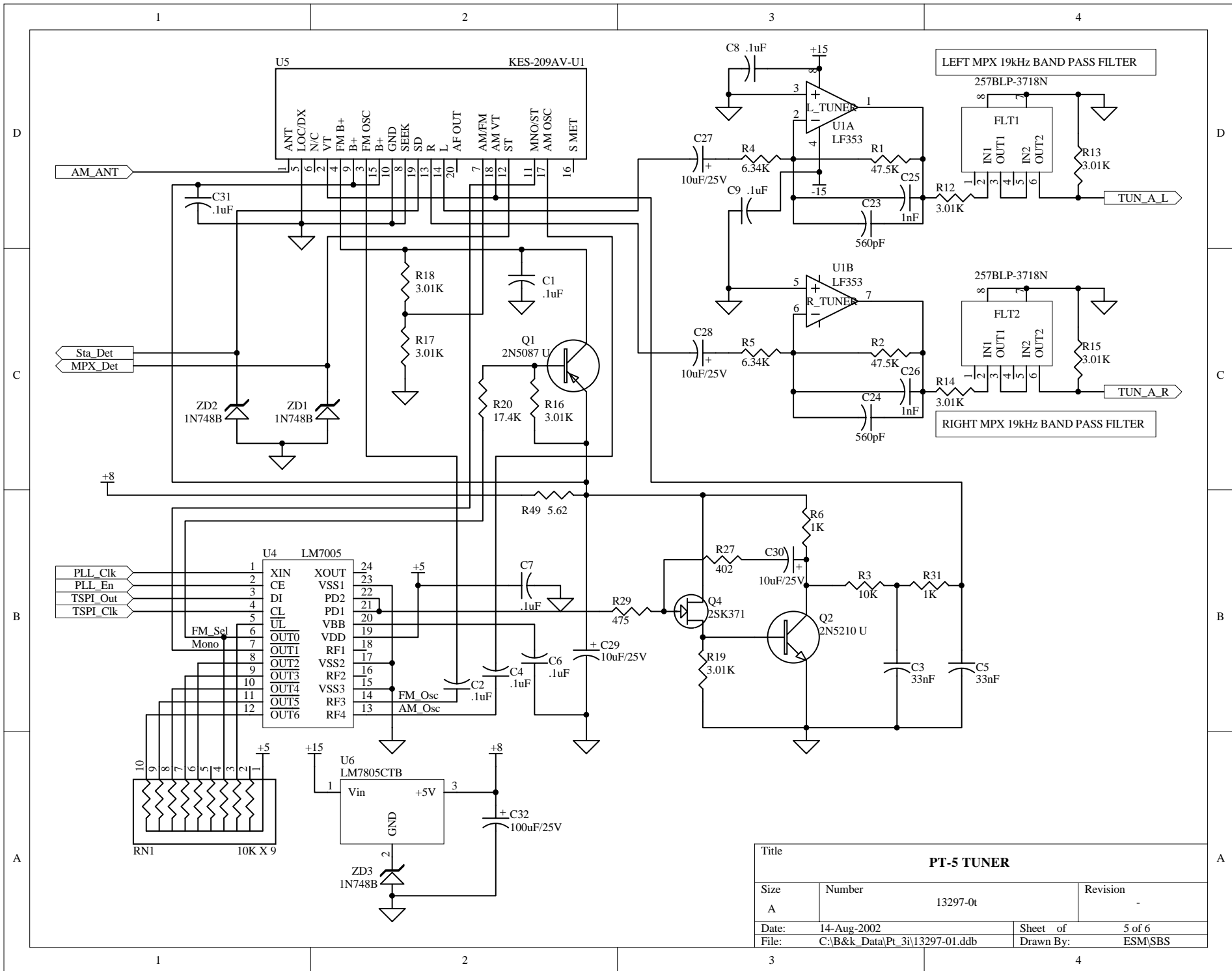

Title			<b>PT-5 TUNER</b>		
Size	Number	Revision			
A	13297-0t				
Date:	14-Aug-2002	Sheet of	5 of 6		
File:	C:\B&k_Data\Pt_3i\13297-01.ddb	Drawn By:	ESM\SBS		

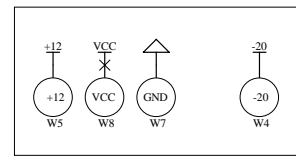
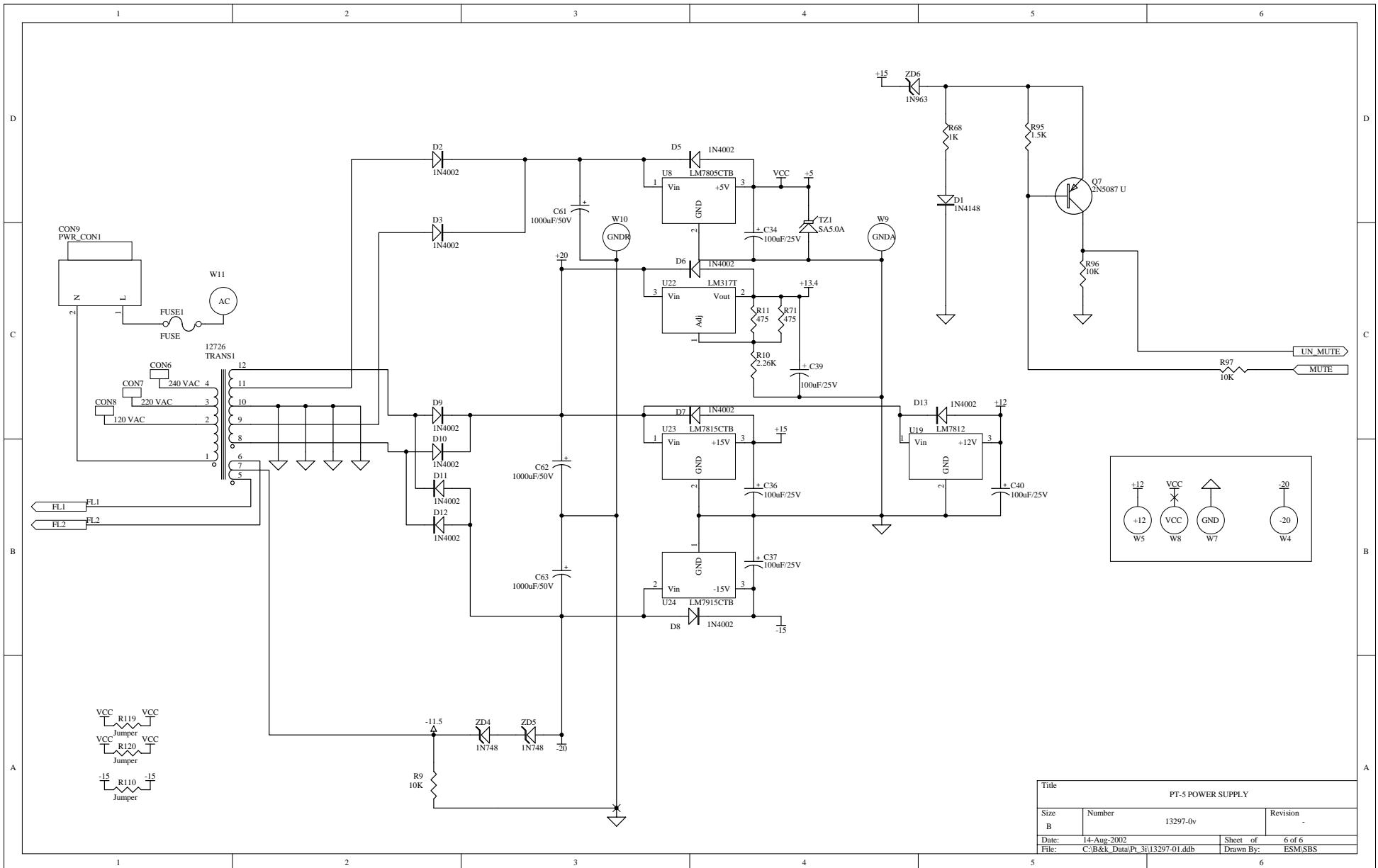

Title			
PT-5 POWER SUPPLY			
Size	Number	Revision	
B	13297-0v	-	
Date:	14-Aug-2002	Sheet of	6 of 6
File:	C:\B&k_Data\Pl_3\13297-01.ddb	Drawn By:	ESM/SBS

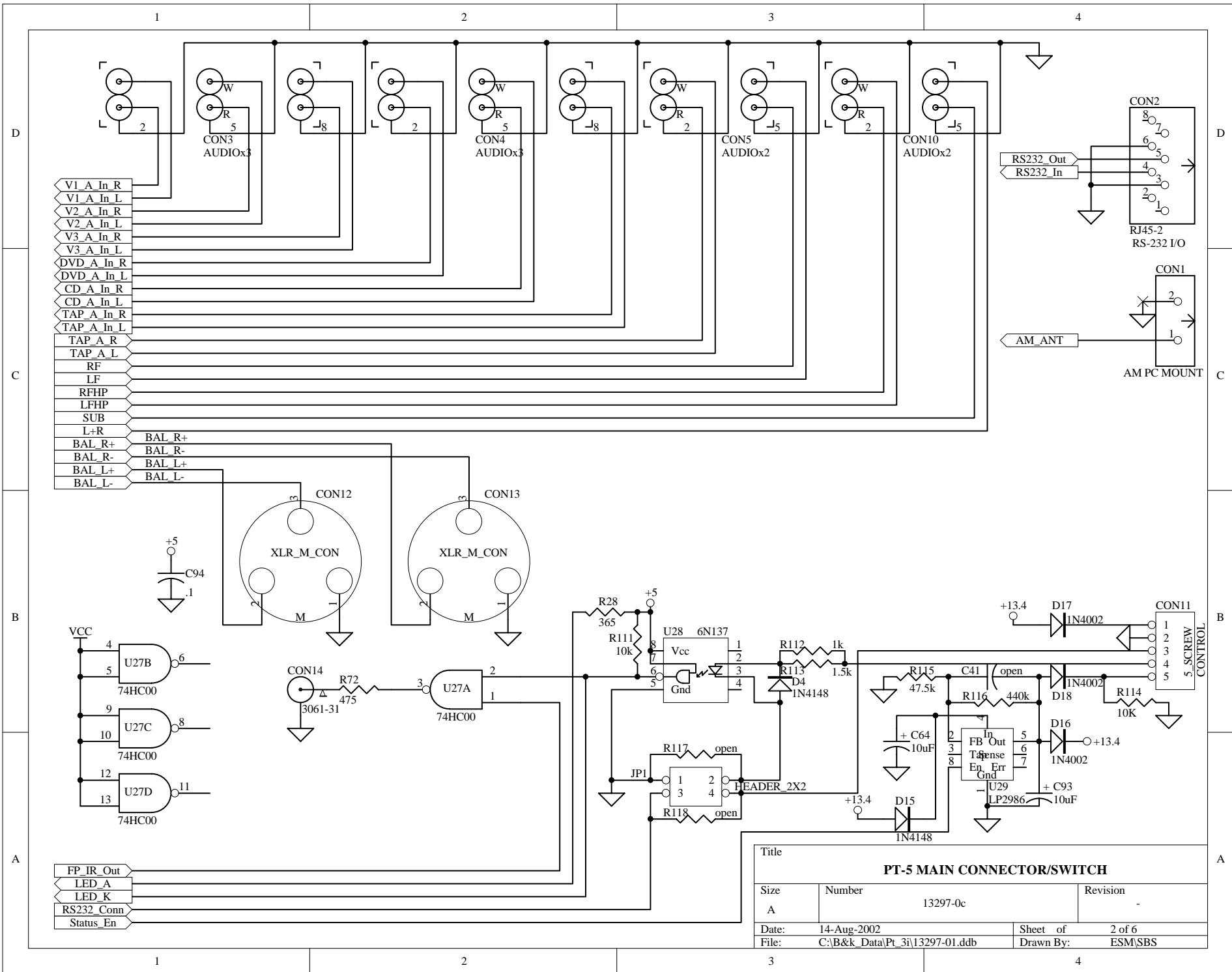

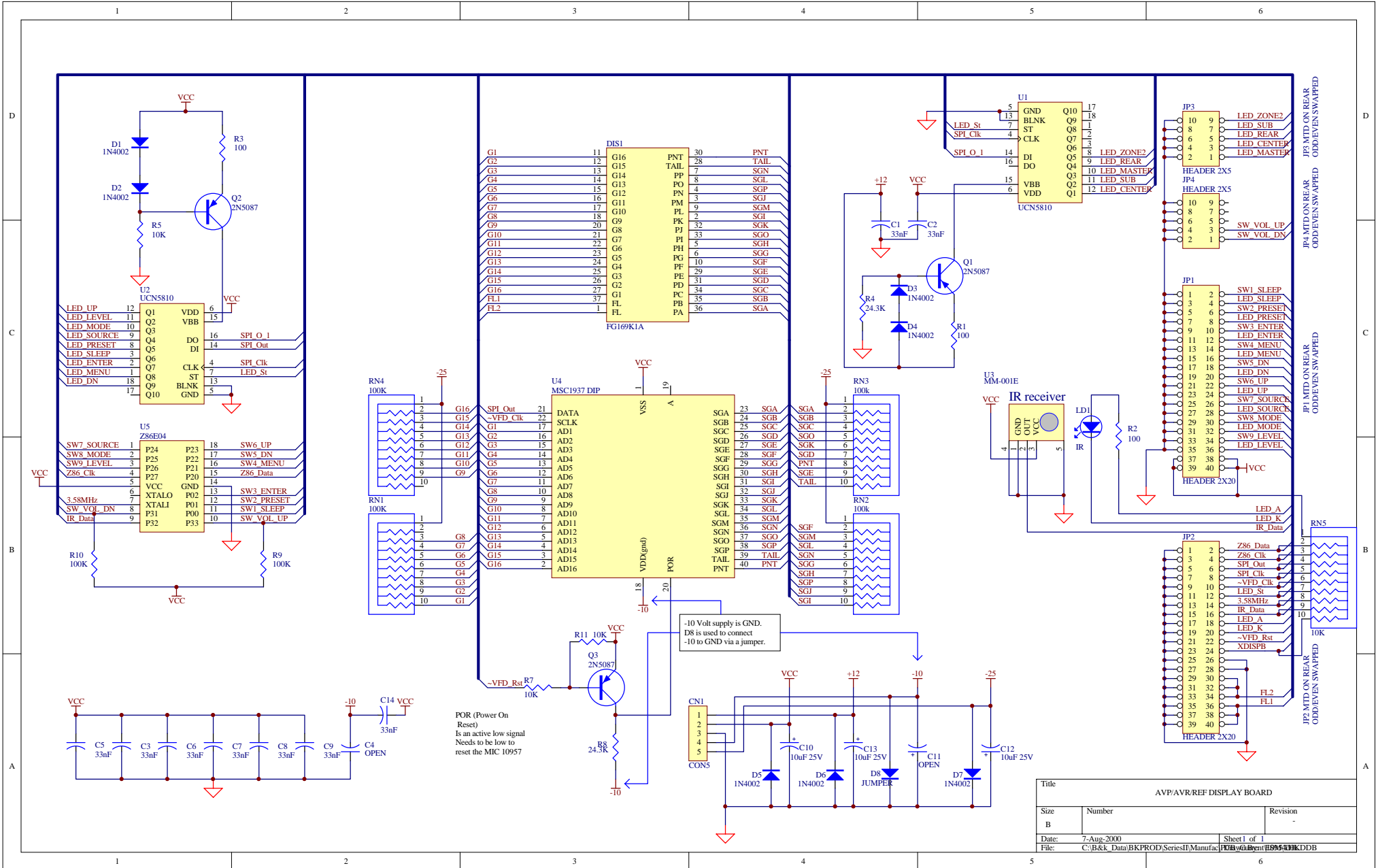

Title		
AVP/AVR/REF DISPLAY BOARD		
Size	Number	Revision
B		
Date:	7-Aug-2000	Sheet 1 of 1
File:	C:\B&K_Data\BKPROD\SeriesI\Manufac\PCB\6161\BSP6161K.DDB	

1

2

3

4

D

D

C

C

B

B

A

A

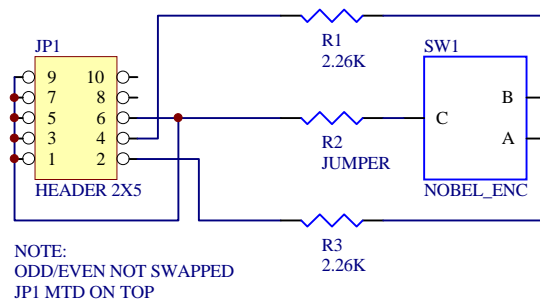

NOTE:  
 ODD/EVEN NOT SWAPPED  
 JP1 MTD ON TOP

Title		
AVP/AVR/REF/TP ROTARY ENCODER BOARD		
Size	Number	Revision
A		A
Date:	7-Aug-2000	Sheet 1 of 1
File:	C:\B&k_Data\BKPROD\SeriesII\Manufact\PCB\B&k\Bent\12760a00.DDB	

1

2

3

4