

ASTOR

ASTOR ELECTRONICS PTY. LTD.

G17AD - 1

DIVISION OF ELECTRONIC INDUSTRIES LTD., BOX 183, P.O. SOUTH MELBOURNE

File: RECEIVERS.AC.

Reg. Office: Astor House, 161-173 Sturt St., South Melbourne.

Date: 19.10.1967

Page: 1

SERVICE DATA

MODEL "G17AD"

that's the difference!

**15 TRANSISTOR BROADCAST BAND RECEIVER AND A
FOUR SPEED STEREO RECORD CHANGER**

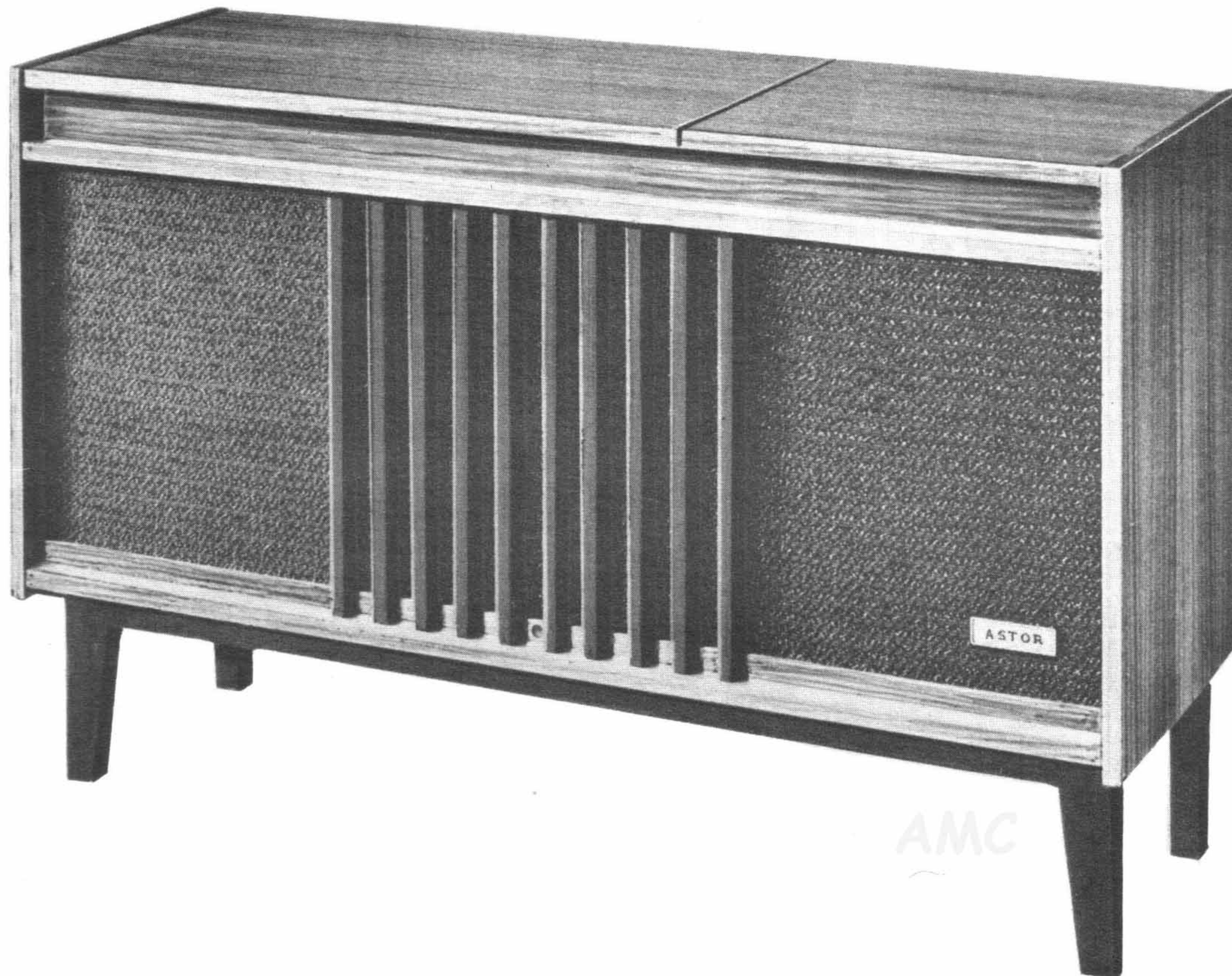

Tuning Range	525 - 1610 Kilocycles
Intermediate Frequency	455 Kilocycles
Power Output	4 Watts each channel
Power Source	240 Volts 50 Cycle
Power Consumption	35 Watts

CAUTION: Disconnect receiver power lead plug from mains cocket before making adjustments inside the Cabinet.

CHASSIS SERIAL NUMBER

The number is stamped into the rear wall of the chassis and is visible when the cabinet back is removed.

Information contained herein must not be reproduced without prior written permission from Astor Electronics Pty.Ltd.

it's an

ASTOR

ALIGNMENT EQUIPMENT

Signal Generator - Modulated 400 cps
Output Meter - 8 ohms impedance
Generator Series Capacitor - .1uF Part No. 4006-005-03
Alignment Tools

that's the difference!

- (a) Flat metal blade end - Part No. 4121-001-01 for I.F.T. and Osc. coil iron core adjustment.
- (b) Hexagonal socket type - Part No. 4121-028-02 for trimmer capacitor adjustment.

ALIGNMENT CONDITIONS

Volume Control - Maximum, clockwise.
Bass Control - Maximum, clockwise.
Treble Control - Maximum, clockwise.
Balance Control - Clockwise position.
Function Switch - "Radio" position, button "in"
Output Level - 50 milliwatts
Output Meter Connection - To right channel speaker socket (speaker disconnected).
Supply Voltage - 240 volt 50 cycle.

INTERMEDIATE FREQUENCY TRANSFORMER ALIGNMENT

Set tuning control to high frequency end of travel.
Insert .1uF capacitor in series with generator "hot" lead.

Oper. No.	Generator Connection	Generator Frequency	Instructions
1.	To pin "C" on "RF" circuit board (term 3 of rod aerial)	455 Kc/s	Adjust iron core of 3rd IF trans. for max. output.
2.	As oper. 1.	455 Kc/s	Adjust iron core of 2nd IF trans. for max. output.
3.	As oper. 1.	455 Kc/s	Adjust iron core of 1st IF trans. for max. output.

SETTING THE DIAL POINTER

Turn tuning spindle until tuning capacitor plates are fully in mesh.

Slide pointer along cord until the pointer aligns with the end of travel spot on dial reading.

BROADCAST ALIGNMENT

- A. To inject a signal into the receiver connect 2 ft. of aerial wire to the "hot" terminal of signal generator. Fashion wire into a vertical position.
- B. Place receiver so that ferrite aerial is uppermost and horizontal.
Tuning end of receiver is to be toward but not less than one foot from generator aerial wire.

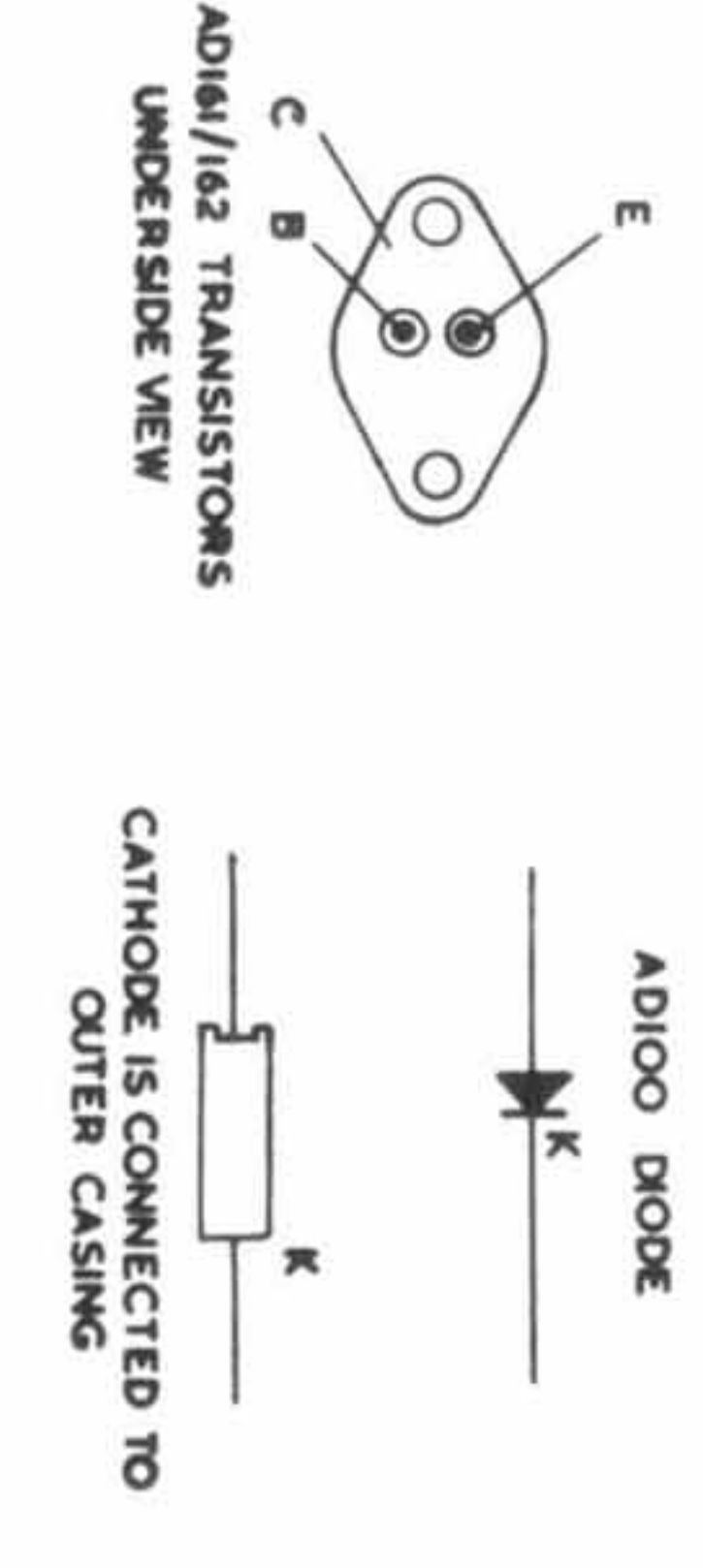
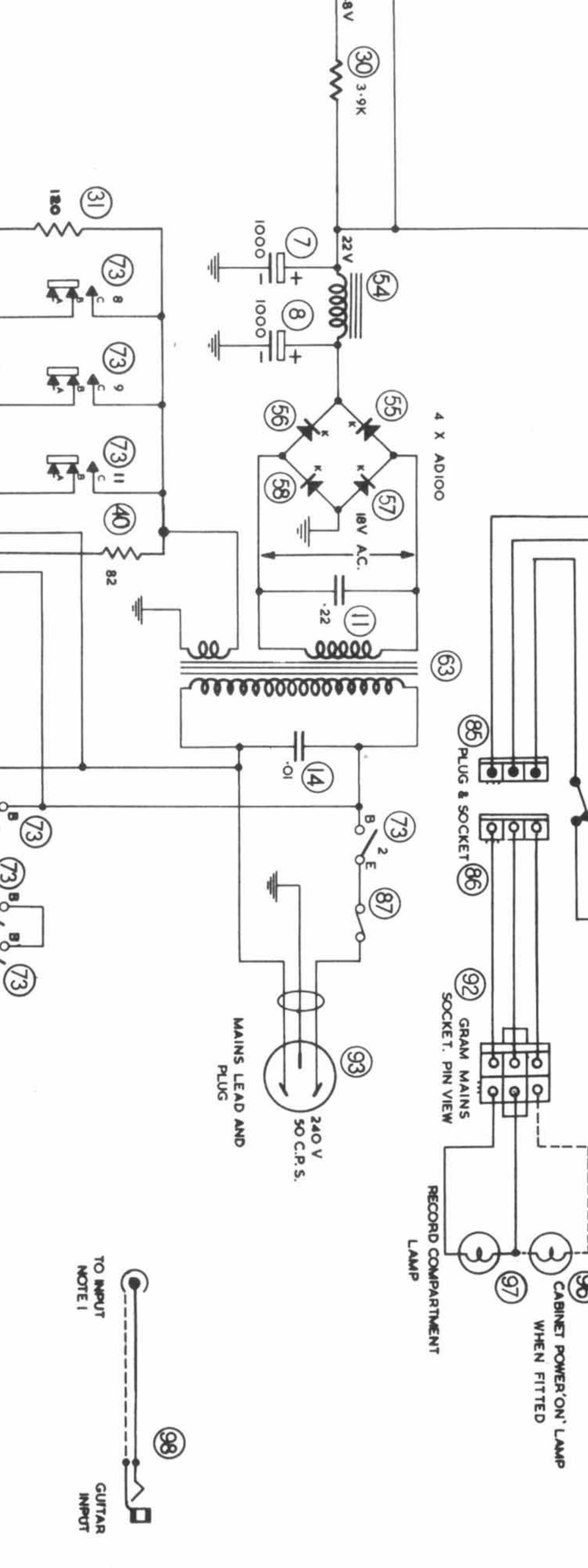
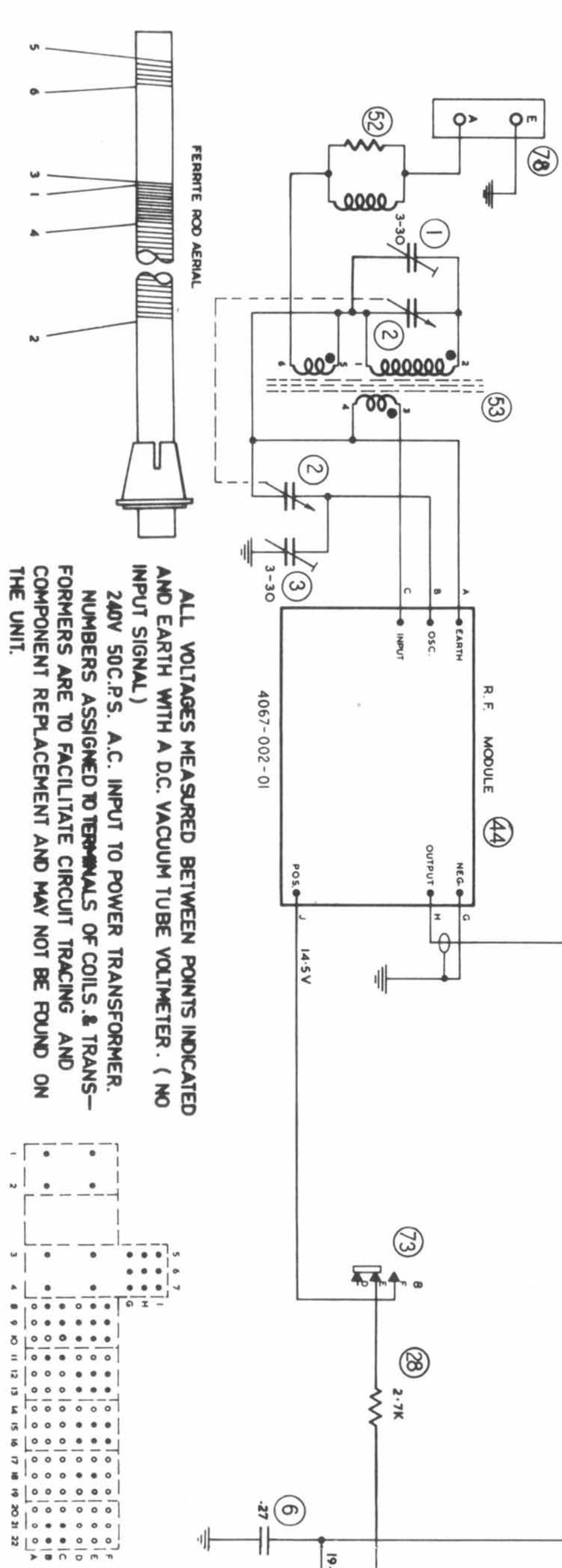

MODELS G17 SERIES

I.F. 455 Kc./s.

DRAWN	DATE	CH'ED	APP'D	DATE
K.L.D.	19.4.67	G.P.	M.G.	4-7-67

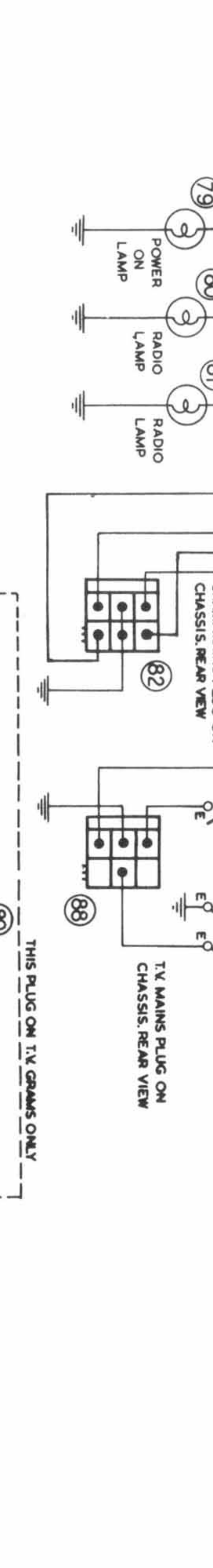
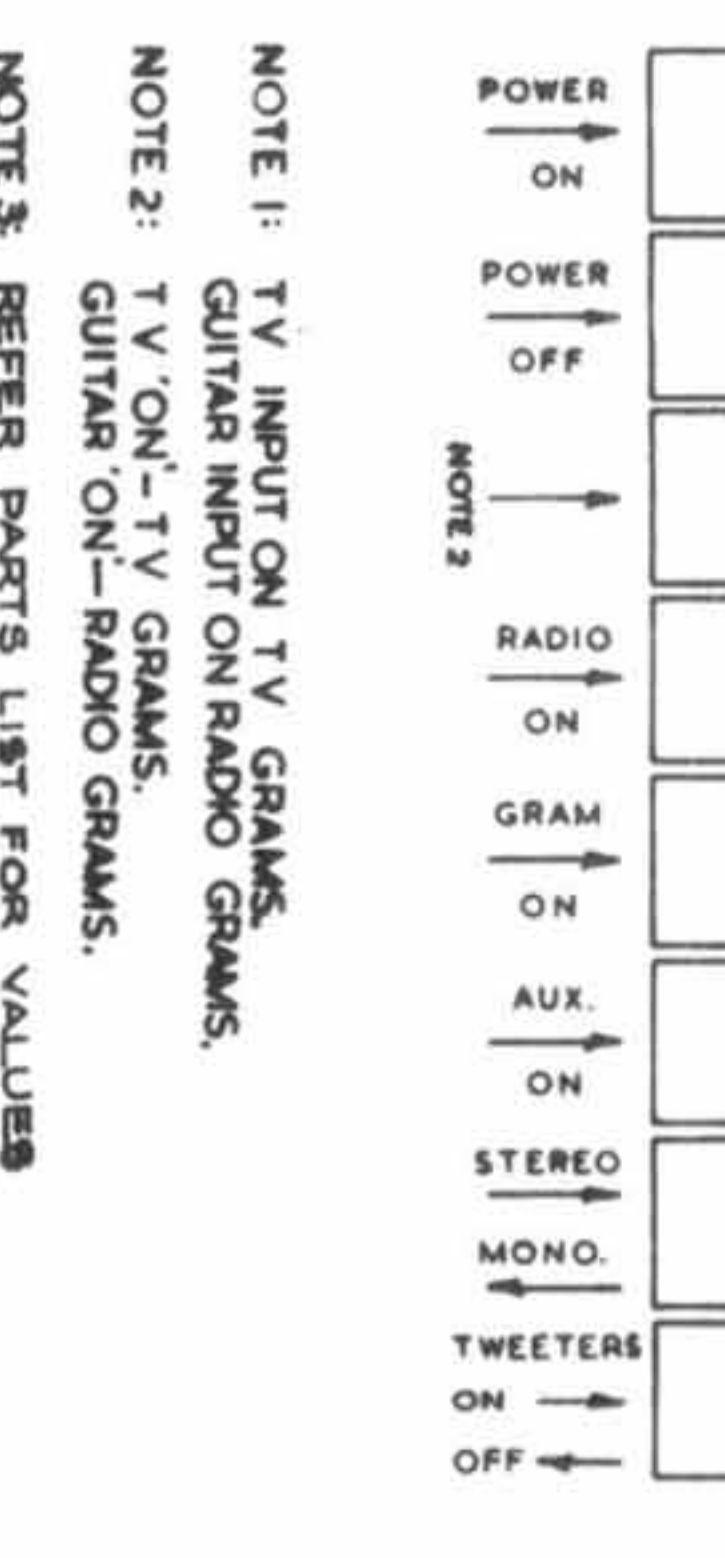

ALL VOLTAGES MEASURED BETWEEN POINTS INDICATED AND EARTH WITH A D.C. VACUUM TUBE VOLTMETER. (NO INPUT SIGNAL.)

240V 50C.P.S. A.C. INPUT TO POWER TRANSFORMER. NUMBERS ASSIGNED TO TERMINALS OF COILS & TRANSFORMERS ARE TO FACILITATE CIRCUIT TRACING AND COMPONENT REPLACEMENT AND MAY NOT BE FOUND ON THE UNIT.

NOTE 1: TV INPUT ON TV GRAMS.
GUITAR INPUT ON RADIO GRAMS.
NOTE 2: TV ON - TV GRAMS.
GUITAR ON - RADIO GRAMS.
NOTE 3: REFER PARTS LIST FOR VALUES OF RESISTORS & CAPACITORS.

FIG145
ISSUE 3.

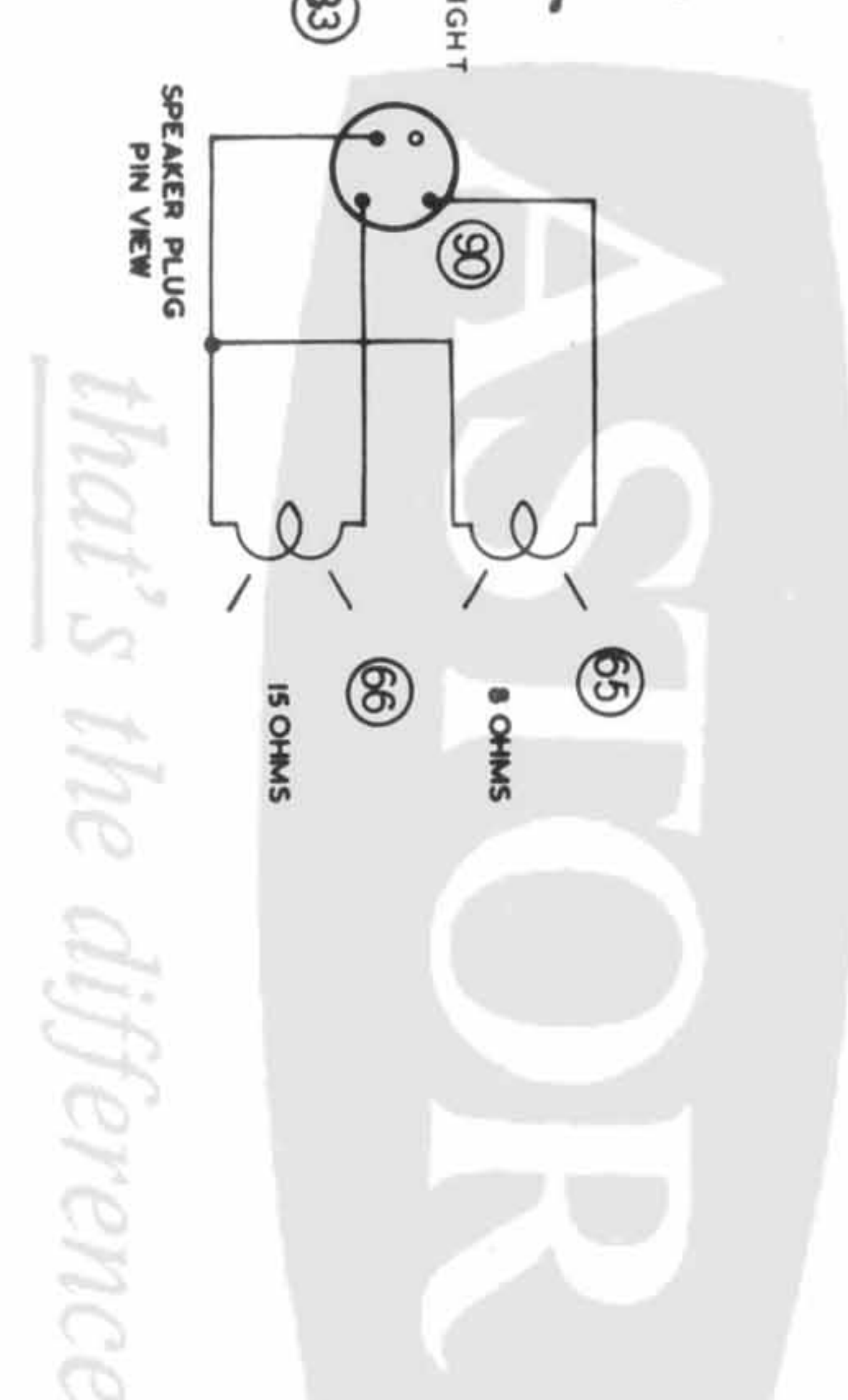

CIRC. NO.	VALUE	CAPACITORS DESCRIPTION	TOL. ±	RATING V.DCW.	PART NUMBER
1	3-30pf	Trimmer - air			4000-025-02
2	3-30pf	Two gang tuning			4000-042-01
3	3-30pf	Trimmer - air			4000-025-03
4	.33uf	Polyester	10%	160	4009-005-14
5	.33uf	Polyester	10%	160	4009-005-14
6	.27uf	Disc Ceramic		25	4005-025-08
7	1000uf	Electrolytic		40	4005-025-08
8	1000uf	Electrolytic		40	4005-025-08
9	640uf	Electrolytic		25	4005-046-02
10	640uf	Electrolytic		25	4005-046-02
11	.22uf	Polyester	10%	160	4002-007-14
12	1uf	Paper	20%	200	4007-023-01
13	1uf	Paper	20%	200	4007-023-01
14	.01uf	Polyester	10%	630	4009-014-12
15	.0039uf	Polyester	5%	400	4009-036-04
16	.0039uf	Polyester	5%	400	4009-036-04
17	.1uf	Disc Ceramic		25	4008-004-04
18	.1uf	Disc Ceramic		25	4008-004-04
19	.1uf	Disc Ceramic		25	4008-004-04
20	.1uf	Disc Ceramic		25	4008-004-04

CIRC. NO.	VALUE	RESISTORS DESCRIPTION	TOL. ±	RATING WATTS	PART NUMBER
21	5.6K	Carbon	10%	.5	4022-022-02
22	5.6K	Carbon	10%	.5	4022-022-02
23	250K	Volume Control - tapped at 25 Kohms			4034-012-01
24	250K	Bass Control			4034-010-01
25	250K	Treble Control			4034-010-01
26	100K	Carbon	10%	.5	4022-013-02
27	100K	Carbon	10%	.5	4022-013-02
28	2.7K	Carbon	10%	.5	4022-043-01
29	500K	Balance Control			4032-021-06
30	3.9K	Carbon	10%	.5	4022-020-01
31	120	Carbon	10%	.5	4022-039-01
32	15	Disc NTC			4021-075-01
33	15	Disc NTC			4021-075-01
34	.68	Wirewound	10%	.5	4024-059-01
35	.68	Wirewound	10%	.5	4024-059-01
36	.68	Wirewound	10%	.5	4024-059-01
37	.68	Wirewound	10%	.5	4024-059-01
38		Not used.			4024-059-01
39		Not used.			

CIRCUIT No.	MISCELLANEOUS	PART NUMBER
44	R.F. module - refer separate list	4067-002-01
45	Right tone module - refer separate list	4067-003-01
46	Left tone module - refer separate list	4067-003-01
47	Right driver module - refer separate list	4067-001-01
48	Left driver module - refer separate list	4067-001-01
49		
50		
51	Loading coil	4036-051-01
52	Ferrite rod aerial	4074-064-01
53	Choke - filter	4048-053-01
54	Diode - type AD100 - bridge rectifier	4127-042-01
55	Diode - type AD100 - bridge rectifier	4127-042-01
56	Diode - type AD100 - bridge rectifier	4127-042-01
57	Diode - type AD100 - bridge rectifier	4127-042-01
58	Diode - type AD100 - bridge rectifier	4127-042-01
59	Transistor - type AD161	4128-109-01
60	Transistor - type AD162	4128-109-01
61	Transistor-type AD161	4128-109-01
62	Transistor-type AD162	4128-109-01
63	Power transformer	4041-054-01
64	Record changer - 4 speed, 200-250 volt 50 cps, Garrard Model 50 Mk II, Sonotone 9TA ceramic cartridge, stylus - stereo diamond 78 sapphire.	4060-002-01

PART NUMBER	MECHANICAL
7215-103-01	Shield-mains leads to switch
7166-007-01	Pillar (2) rod aerial mount
7225-078-01	Clip (2) rod aerial mount
7279-005-02	Nut Plate (2) rod aerial mount pillar
7222-115-01	Socket (3) dial lamps
7055-291-51	Clip (3) dial lamp sockets
7106-032-01	Grommet (4) gang mount
7031-017-01	Bush (4) gang mount
7196-067-03	Screw (4) 5/16" x 4BA C/SK.Hd. gang mount
7077-034-01	Dial drum
7198-801-02	Grab screw (2) 3/16" x 1/8" Whit. dial drum
7225-129-01	Spring - dial cord
7174-015-01	Pulley (3) dial cord
7055-250-01	Clip (3) dial cord pulley
7262-024-01	Washer (5) 3/8" Int.S/P. - controls
7150-057-01	Nut (5) 3/8" U.N.F. - controls
7196-275-13	Screw (3) 3/16" x 6BA Ch.Hd. - Switch
7215-103-01	Shield-mains leads to switch
7215-102-02	Shield-switch
7215-098-01	Shield-controls
7120-199-01	Mica insulator (4) - (supplied with
7120-200-01	Bush insulator (4) - (output transistors
7120-029-02	Grommet (3) leads
7169-558-01	Fuse holder
7065-206-01	Cover-fuse holder
7345-006-01	Anchor-mains cord
7231-122-01	Terminal strip (2) 7 lug - 1E3E1
7231-203-01	Terminal strip (1) 5 lug - 2E2
7231-083-01	Terminal strip (2) 6 lug - 1E201E
7231-101-01	Terminal strip (1) 2 lug - 1E
7231-102-01	Terminal strip (5) 3 lug - 1E1

PART NUMBER	MECHANICAL
7231-105-01	Terminal strip (1) 6 lug - 1E4
7060-073-11	Contact (16) Gram and T.V. power plugs
7138-070-22	Solder lug (7) lead dressing
7055-539-01	Clip (4) lead anchor
7215-100-01	Shield (2) top, tone module
7120-205-01	Insulator (2) shield, top
7120-201-01	Module Mounting - 1st production runs
7293-012-02	Spacer (8) brass
7198-076-11	Screw (8) 3/8" x 1/2" Whit. rd.hd.
7148-302-12	Nut (8) 3/8" Whit.
7262-008-02	Washer (8) shakeproof, 3/8" int.
7215-101-51	Shield (2) base, tone module
7120-201-01	Insulator (2) shield base
7294-110-01	Module Mounting - current production runs
7201-576-06	Spacer (8) moulded
7215-101-01	Screw (8) 1/2" x No.4 Phillips hd.
7120-201-11	Shield (2) base, tone module
7224-007-04	Insulator (2) shield, base.
7224-008-08	Tuning Spindle Assy. consists of
7174-009-01	Spindle
7031-025-01	Pulley
7261-028-01	"C" washer
7124-440-01	Knob (2) grey - push button
7124-440-02	Knob (4) black - push button
7124-440-03	Knob (1) red - push button
7124-440-04	Knob (1) light grey - push button
7055-536-01	Knob (16) push button knobs
7124-438-01	Knob (5) rotary controls
7186-010-01	Clip (5) rotary control knobs
7070-122-01	Dial Reading
7173-068-01	Dial Pointer
7150-854-34	Barrel Nut (2) long
7150-854-24	Barrel Nut (1) short, tuning bush only.
7293-037-01	Spacer (2) "DIN" socket mounting
1107-002-02	Dial Cord 78" required.

Colour	Cabinet	Extrusions
MAPLE	7038-019-01	7130-054-01
WALNUT	7038-019-02	7130-054-02
MAHOGANY	7038-019-03	7130-054-03
TEAK	7038-019-04	7130-054-04

NOTE: After the 1st production run the satin light grey extrusions used on the TEAK cabinets will be discontinued. Future production cabinets will be fitted with natural satin finish extrusions.

MECHANICAL COMPONENTS - CABINET

Part	Material
Badge - "ASTOR"	
Nut (2) badge	
Fabric - 5.25 sq.ft.	
Pad (4) lid buffers	
Tee Nut (4) leg mount	
Hinge (4) lids	
Screw (8) 1" x No.6 rd hd. - hinge	
Screw (8) 5/8" x No.6 rd hd. - hinge	
Lid Stay Assy (2) not available complete	
Includes:	
Stay Assy.	
Bracket Housing	
Plastic Washer (2)	
Washer (3) flat steel	
Spring	
Screw - tension adjustment	
Tee Nut - tension adjustment	
Packer Plate	
Wood Screw (8) 3/4" x No.4 rd.hd. lid stay.	
Wood Screw (4) 1/2" x No.4 csk hd. lid stay.	
Light Button (2) power "ON" indicator	
Clip (1) lamp socket.	
Socket (1) cabinet "ON" indicator.	

Oper. No.	Generator Connection	Generator Frequency	Instructions
1.	Refer Para. A. & B.	525 Kc/s	Tuning capacitor plates fully meshed against end of travel stop. Adjust oscillator coil iron core and rod aerial adjusting ring for maximum output.
2.	As per oper. 1	1610 Kc/s	Set tuning pointer to 1610Kc spot on dial. Adjust oscillator and aerial trimmer capacitors for maximum output.
3.	As oper. 1	600 Kc/s	Tune receiver to generator signal and adjust rod aerial adjusting ring for maximum output.
4.	As oper. 1	1400 Kc/s	Tune receiver to generator signal and adjust aerial trimmer capacitor for maximum output.

ADJUSTMENT OF COLLECTOR CURRENT

This should be performed after a driver module or output transistors or associated componentry have been replaced.

EQUIPMENT Current Meter - 0-50mA. DC. terminated with lead and socket assy. Part No. 4078-018-01, positive terminal to red sleeve.

CONDITIONS Volume Control set at minimum. No input signal.
Connect an 8 ohm impedance speaker to receiver socket.
Remove link from pins "O" and "N" on Driver Module board.
Place meter lead socket on to test pins "O" and "N". Connector with red sleeving is to be connected to pin "N".

Adjust 100 ohm potentiometer circuit No. 15 until a meter reading of 20 mA. \pm 2 mA. is indicated.

Remove meter lead plug and reconnect link to test pins.

AUDIO AMPLIFIER GAIN AND BALANCE TEST

Audio Frequency Generator	-	1000 cps.- 600 ohms impedance.
Output Meter	-	8 ohms
Volume Control	-	Maximum, clockwise
Bass Control	-	Maximum, clockwise
Treble Control	-	Maximum, clockwise
Balance Control	-	Clockwise position
Function Switch	-	GRAMO button "in" MONO button "out"

Disconnect pick-up leads from input sockets.
Connect audio generator output leads to an input socket.
Connect an 8 ohm speaker to one output socket and the output meter to the other output socket.
Set the output of audio generator to 16 millivolts.
With equipment connected as above, the output meter should read a minimum of 50 milliwatts.

Exchange output meter and speaker connections to opposite channels. Turn Balance control to anticlockwise position.

Difference in output between the two readings must not exceed 2dB.

ASTOR

it's an
that's the difference!

SPEAKER PHASING

It is essential that the speakers be phased correctly.

If a speaker has to be removed for service, note the lead connections to ensure correct phasing when reconnecting.

A method used for checking the phasing of the speakers is detailed in the following paragraphs.

1. Play a monophonic record.
2. To conduct the following test the listener should be located at a position four feet away in front of the centre of the cabinet.
3. If the phasing is correct the reproduced sound will appear to be radiated from a point near the centre of cabinet front.
4. With incorrect phasing the quality of reproduction will be poor, it will appear to be lacking in bass response and will appear to be radiated from both ends of the Cabinet.
5. If the speakers are incorrectly phased, reverse the leads connected to the voice coil terminals of one of the large speakers then repeat the test detailed above.

NOTE: that the terminal colours on each "small" speaker correspond with the adjacent large speaker connections.

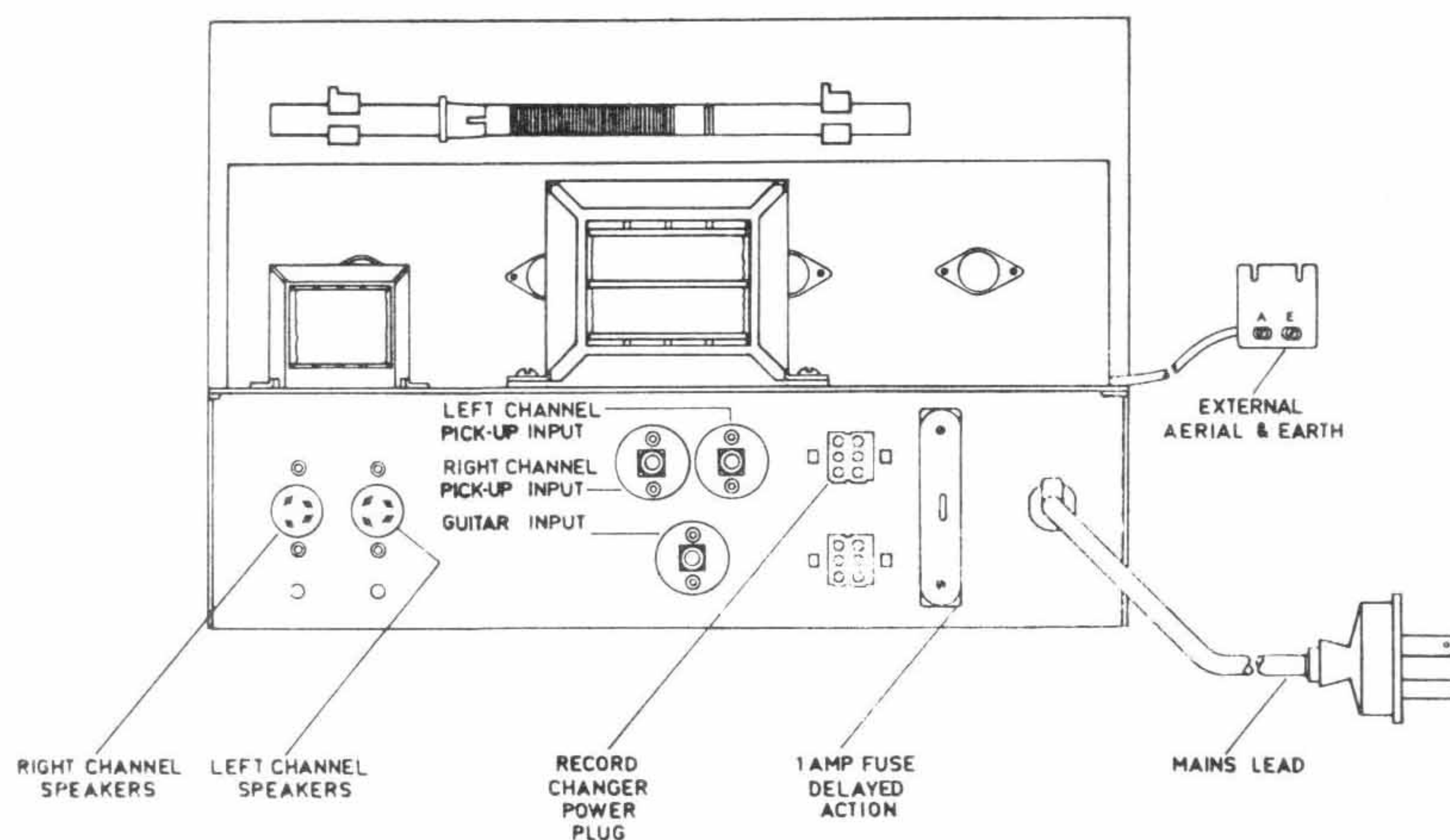
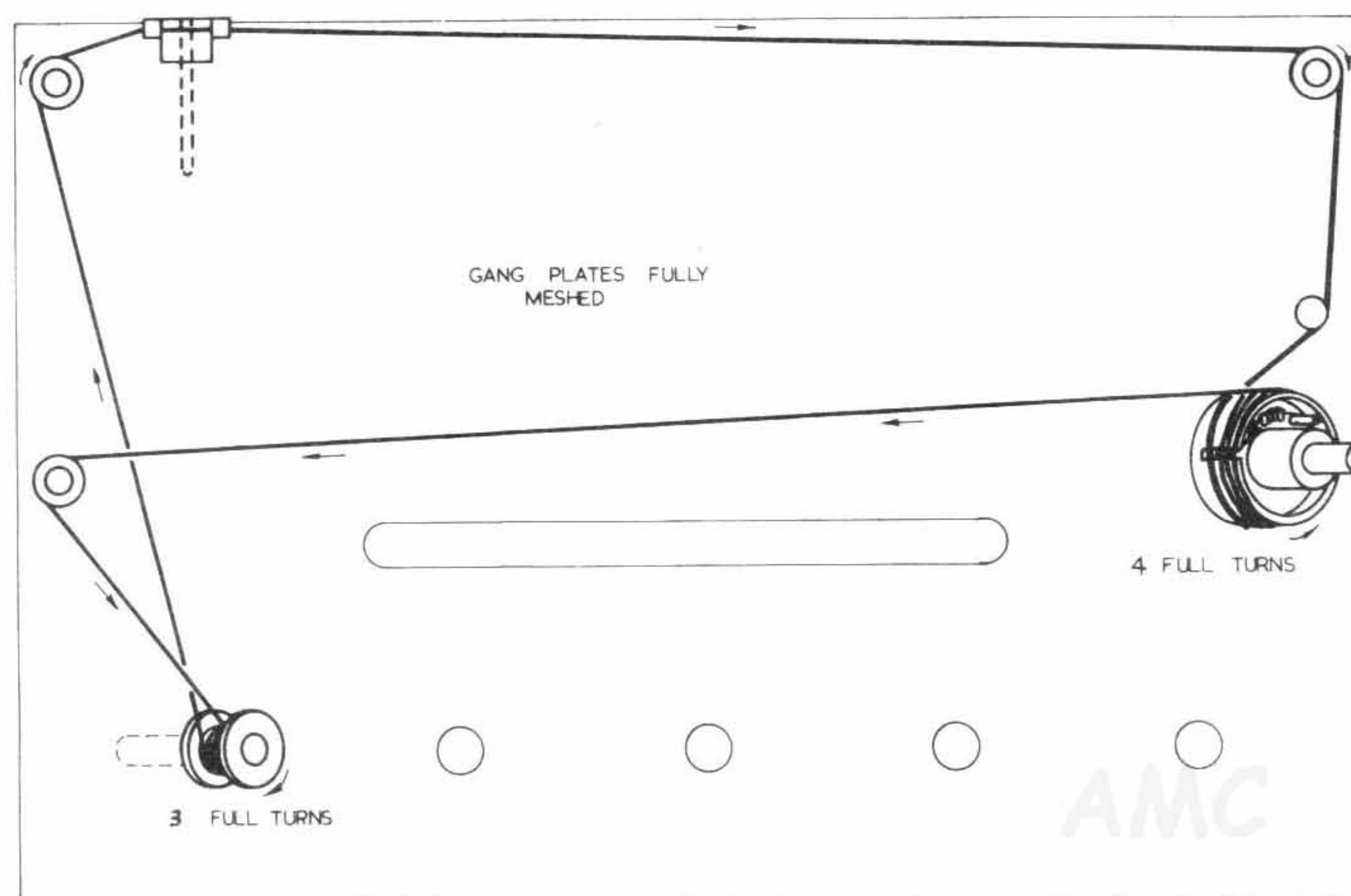

CHASSIS REMOVAL

1. Disconnect mains lead plug from supply socket then remove rear panel of cabinet.
2. Identify connections then remove plugs from receiver sockets. Remove ext.aerial and earth terminal plate.
3. Remove rotary control knobs and the three barrel nuts.
4. Remove the four screws fastening support brackets to cabinet.
5. Chassis may be lowered and removed from cabinet.
6. Reverse procedure when refitting.

RECORD CHANGER REMOVAL

1. Disconnect mains lead plug from supply socket then remove rear panel of cabinet.
2. Identify connections then remove pick-up lead plugs and the motor mains lead plug from the changer sockets.
3. Screw down the changer transport screws then turn the retainer clips to the vertical position.
4. Changer may be lifted off the cabinet motor board and out of cabinet.
5. Reverse procedure when refitting.

PICK-UP STYLUS PRESSURE ADJUSTMENT

The stylus pressure is to be 4 grammes. A pressure gauge Part No.4121-013-01 is available from the Spare Parts Division.

To check the pressure ensure the unit is level with no record on the turntable. Place pressure gauge on the turntable then lower pick-up arm so that stylus locates into the hollow provided on gauge. Adjust for balance and note reading.

To adjust the pressure move the slider on top of pick-up arm frontwards to decrease and backwards to increase. Recheck with gauge.

DRIVER MODULE PART NO. 4067-001-01

CIRCUIT NO.	VALUE	CAPACITOR DESCRIPTION	TOL + -	RATING V.DCW.	PART NUMBER
1	1.6 uF	Electrolytic		25	4005-047-01
2	5uF	Electrolytic		25	4005-018-12
3	250uF	Electrolytic		15	4005-011-17
4	.0068uF	Polyester		400	4009-004-08
5	100pF	Disc Ceramic	5%	500	4008-006-11

CIRCUIT NO.	VALUE OHMS	RESISTORS DESCRIPTION	TOL + -	RATING WATTS	PART NUMBER
7	2.2K	Carbon	10%	1/2	4022-021-06
8	47K	Carbon	10%	1/2	4022-051-03
9	390K	Carbon	5%	1/2	4022-050-04
10					
11	470K	Carbon	5%	1/2	4022-045-05
12	4.7K	Carbon	10%	1/2	4022-005-01
13	12	Carbon	5%	1/2	4022-069-09
14	1K	Carbon	5%	1/2	4022-008-14
15	100	Potentiometer, Quiescent Current Adj.			4025-031-03
16	270	Carbon	10%	1	4022-071-03
17	68	Carbon	10%	1/2	4022-024-01

CIRCUIT NO.	MISCELLANEOUS	PART NUMBER
21	Transistor - type SE 4002 - Audio Amp.	4128-066-01
22	Transistor - type AX 6123 - Audio Driver	4128-108-01

MECHANICAL

PART NUMBER	DESCRIPTION
7167-058-01	Pin (12) Circuit board terminations
7120-026-01	Insulator (2) glass, transistor mount.
7111-053-02	Heat Sink (1) audio driver amp transistor.

AMC

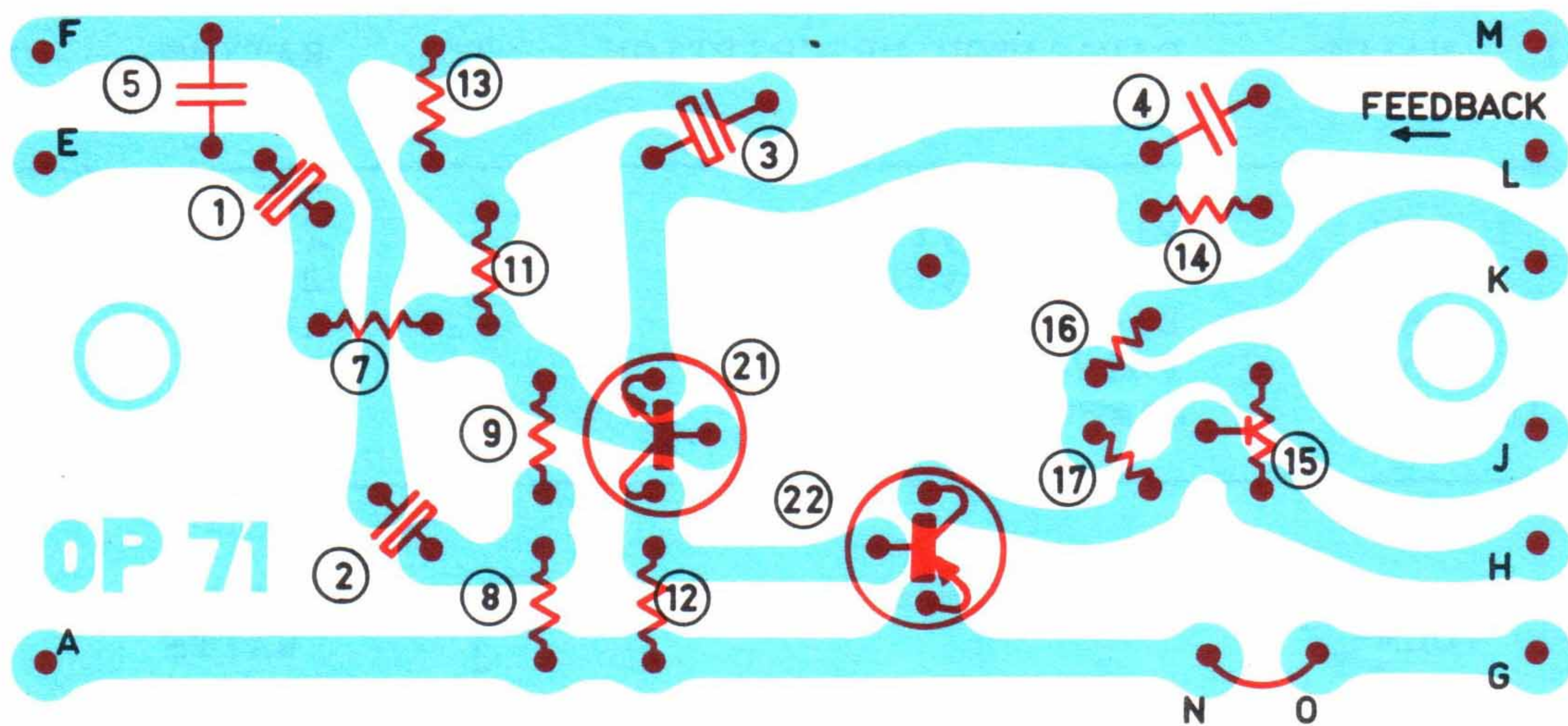

DR'WN	DATE	CH'ED	APP'D	DATE
K.J.D.	12.4.67	G.L.	V.H.	15-5-67

ISSUE 2 CIRCUIT NO 5 ADDED

PBI535 A3

AMC

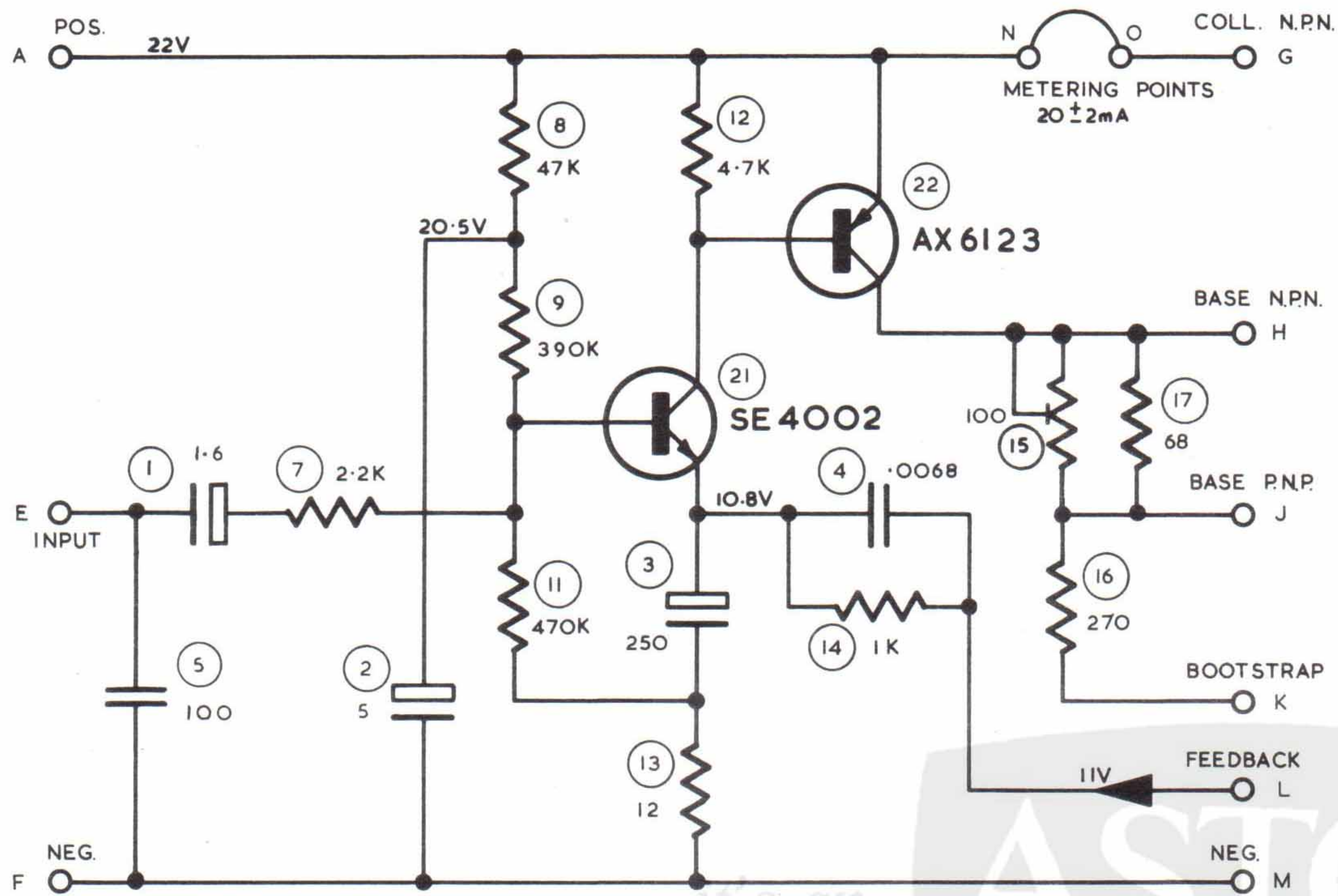

SE 4002 TRANSISTOR

AX 6123 TRANSISTOR

DRIVER MODULE

PART NO. 4067-001-01

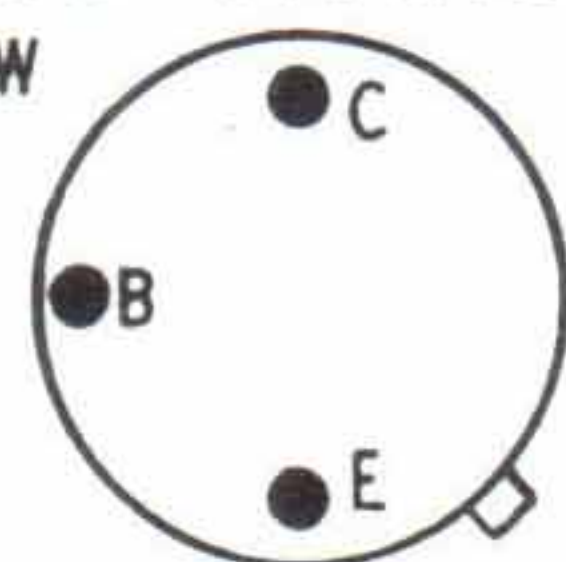
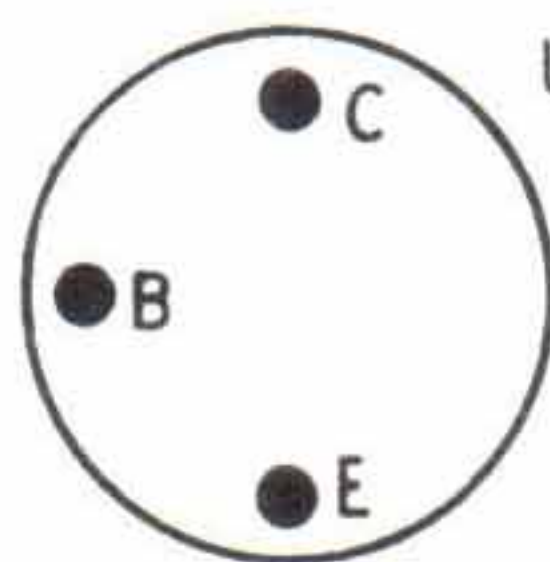

DR'WN	DATE	CH'ED	APP'D
G. B.	11-11-66	G.L.	V.H.

that's the difference!

ISSUE 2 (1) WAS 5 uF. (5) 100pF ADDED

PBI534

Circuit No.	Value	Capacitors Description	Tol. ±	Rating V.DCW	Part Number
1	.01uF	Disc Ceramic		25	4008-039-06
2	.01uF	Disc Ceramic		25	4008-039-06
3	220pF	Polystyrene	5%	100	4004-005-03
4	.022uF	Disc Ceramic		25	4008-010-05
5	10uF	Electrolytic		6	4005-007-12
6	.022uF	Disc Ceramic		25	4008-010-05
7	.022uF	Disc Ceramic		25	4008-010-05
8	220pF	Polystyrene	5%	100	4004-005-03
9	.1uF	Disc Ceramic		25	4008-004-04
10					
11	.1uF	Disc Ceramic		25	4008-004-04
12	.022uF	Disc Ceramic		25	4008-010-05
13	.022uF	Disc Ceramic		25	4008-010-05
14	.022uF	Disc Ceramic		25	4008-010-05
15	100pF	Ceramic	5%	500	4008-006-11
16	220pF	Polystyrene	5%	100	4004-005-03
17	100pF	Ceramic	5%	500	4008-006-11
18	.22uF	Disc Ceramic		25	4008-053-01
19	80uF	Electrolytic		25	4005-030-03
20					
21	100pF	Ceramic		25	4008-006-11
22	.01uF	Disc Ceramic		25	4008-039-06
23					
24					

Circuit No.	Value Ohms	Resistors Description	Tol. ±	Rating Watts	Part Number
25					
26	47K	Carbon	10%	$\frac{1}{2}$	4022-051-03
27	10K	Carbon	10%	$\frac{1}{2}$	4022-004-01
28	2.7K	Carbon	10%	$\frac{1}{2}$	4022-043-01
29	120K	Carbon	10%	$\frac{1}{2}$	4022-031-01
30	10K	Carbon	10%	$\frac{1}{2}$	4022-004-01
31	560	Carbon	10%	$\frac{1}{2}$	4022-010-01
32	1K	Carbon	10%	$\frac{1}{2}$	4022-008-01
33	10K	Carbon	10%	$\frac{1}{2}$	4022-004-01
34	100K	Carbon	10%	$\frac{1}{2}$	4022-013-02
35	1K	Carbon	10%	$\frac{1}{2}$	4022-008-01
36					
37	2.2K	Carbon	10%	$\frac{1}{2}$	4022-021-02
38	4.7K	Carbon	10%	$\frac{1}{2}$	4022-005-01
39	33K	Carbon	10%	$\frac{1}{2}$	4022-059-03
40					
41	68	Carbon	10%	$\frac{1}{2}$	4022-024-01
42	820	Carbon	10%	$\frac{1}{2}$	4022-009-01
43	1K	Carbon	10%	$\frac{1}{2}$	4022-008-01
44	330K	Carbon	10%	$\frac{1}{2}$	4022-047-01
45	150K	Carbon	10%	$\frac{1}{2}$	4022-038-01
46	27K	Carbon	10%	$\frac{1}{2}$	4022-073-01
47					
48					
49					

ASTOR

it's an

that's the difference!

AT319

AT319

AT319

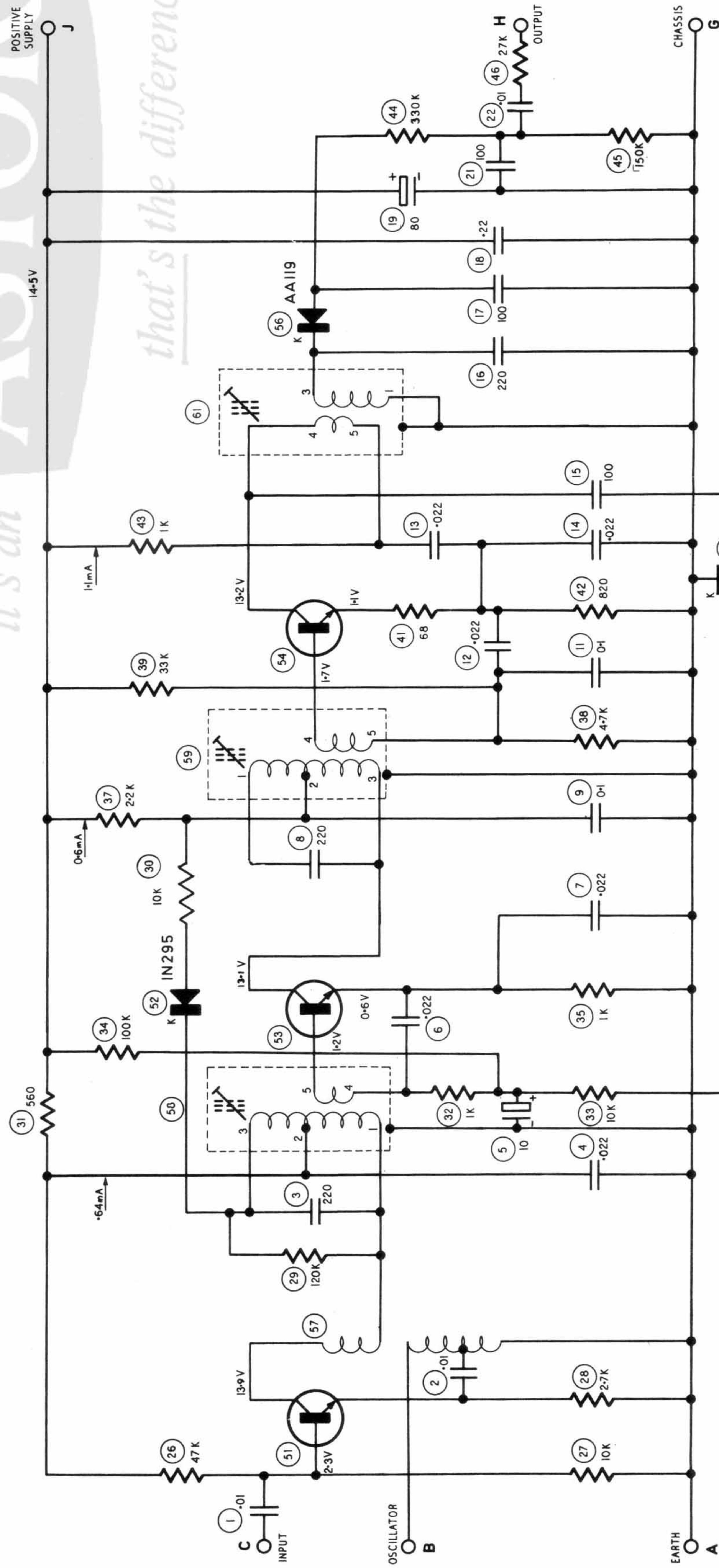

OSC. COIL
& I.F. TRANSFORMER
UNDERSIDE VIEW

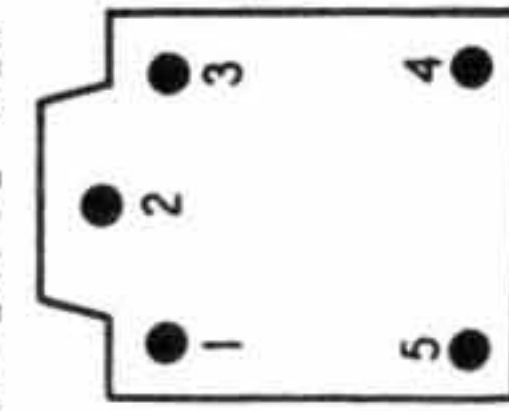

TRANSISTORS
AT319
TYPE NP

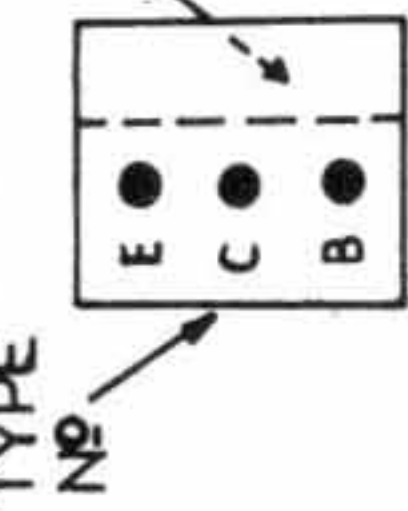

AA119 DIODE

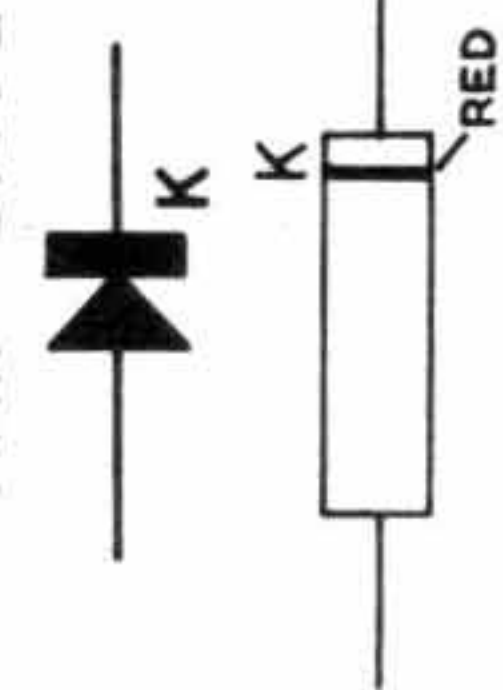

IN295 DIODE

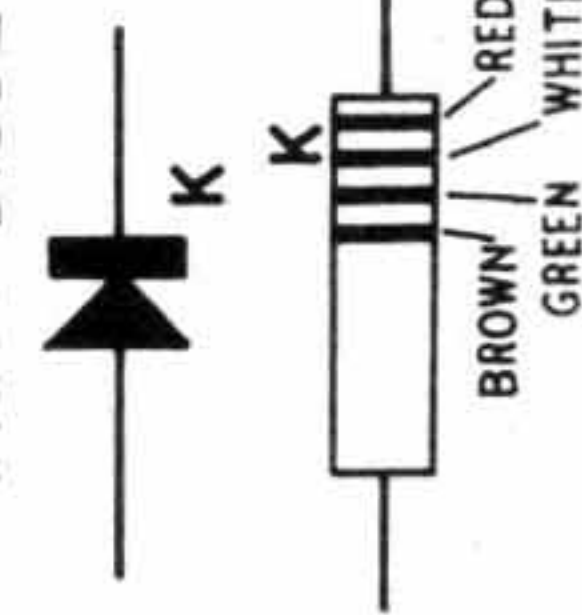

R.F. MODULE
PART No. 4067-002-01

DRWN	DATE	CH'ED	APP'D	DATE
B.C.A.	11-11-66	92	[Signature]	4-7-67

PB1547 ISSUE 2



it's an

that's the difference!

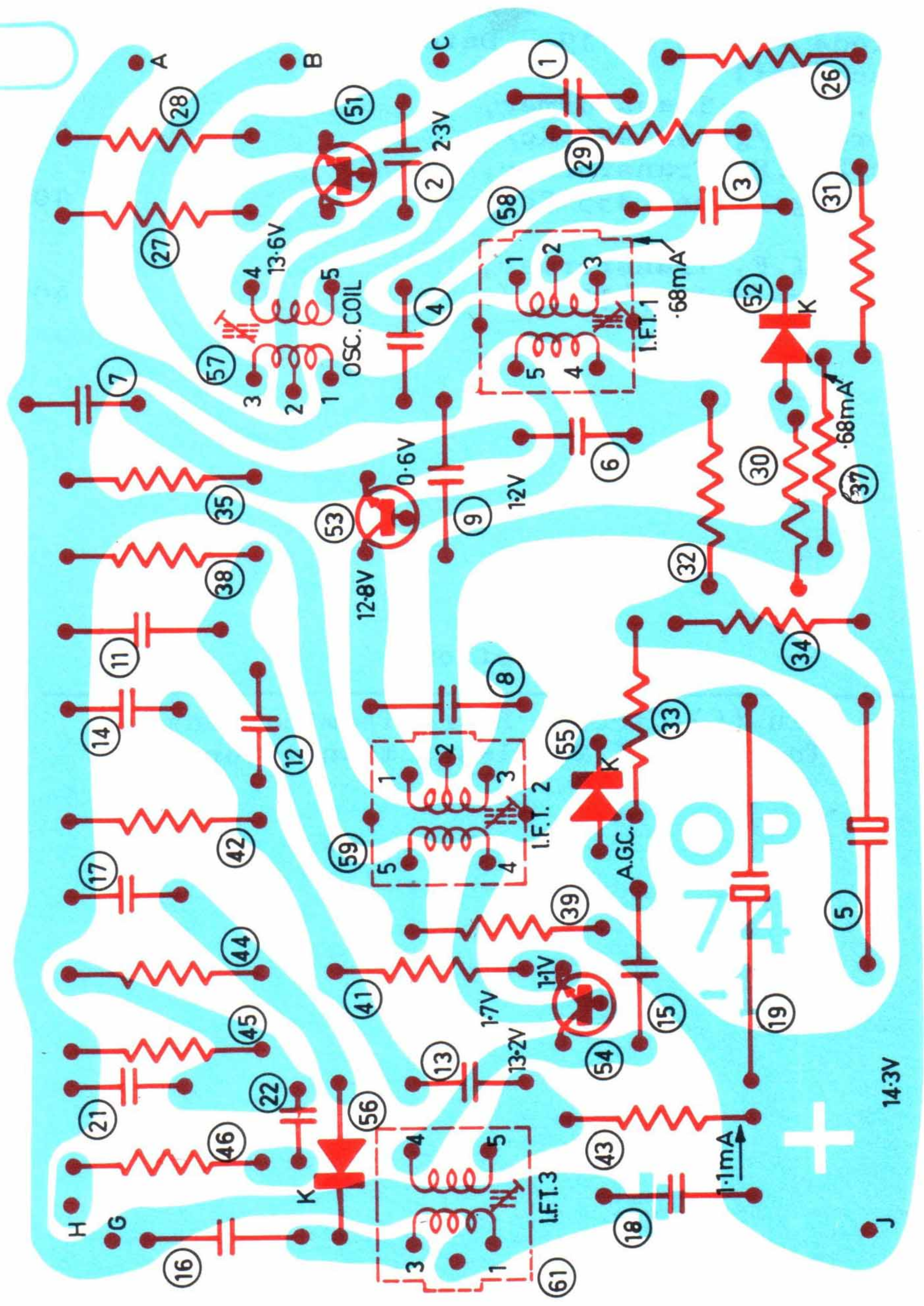

DRAWN	DATE	CH'ED.	APP'D.	DATE
K.J.D.	3.7.67.	GL.	W.L.	15-7-67

ISSUE 2

PBI546 A

AMC



Circuit
No.

Miscellaneous

Part
Number

50		
51	Transistor - type AT319 - Mixer/osc.	4128-118-01
52	Diode-type 1N295 - overload	4127-001-01
53	Transistor - type AT319 - I.F.Amp.	4128-118-01
54	Transistor - type AT319 - I.F.Amp.	4128-118-01
55	Diode - type 1N295 - A.G.C.	4127-001-01
56	Diode - type AA119 - Detector	4127-037-01
57	Osc. Coil	4043-064-01
58	No.1 I.F. Transformer, orange/green, 455 Kc/s	4044-031-01
59	No.2 I.F. Transformer, orange/blue, 455 Kc/s	4044-031-02
60		
61	No.3 I.F. Transformer, orange/violet, 455 Kc/s	4044-031-03

Mechanical

Part Number

Description

7167-058-01	Pin (6) Circuit Board Terminations
7120-026-01	Insulator (12) glass, transistor mount

TONE CONTROL MODULE. PART NUMBER 4067-003-01

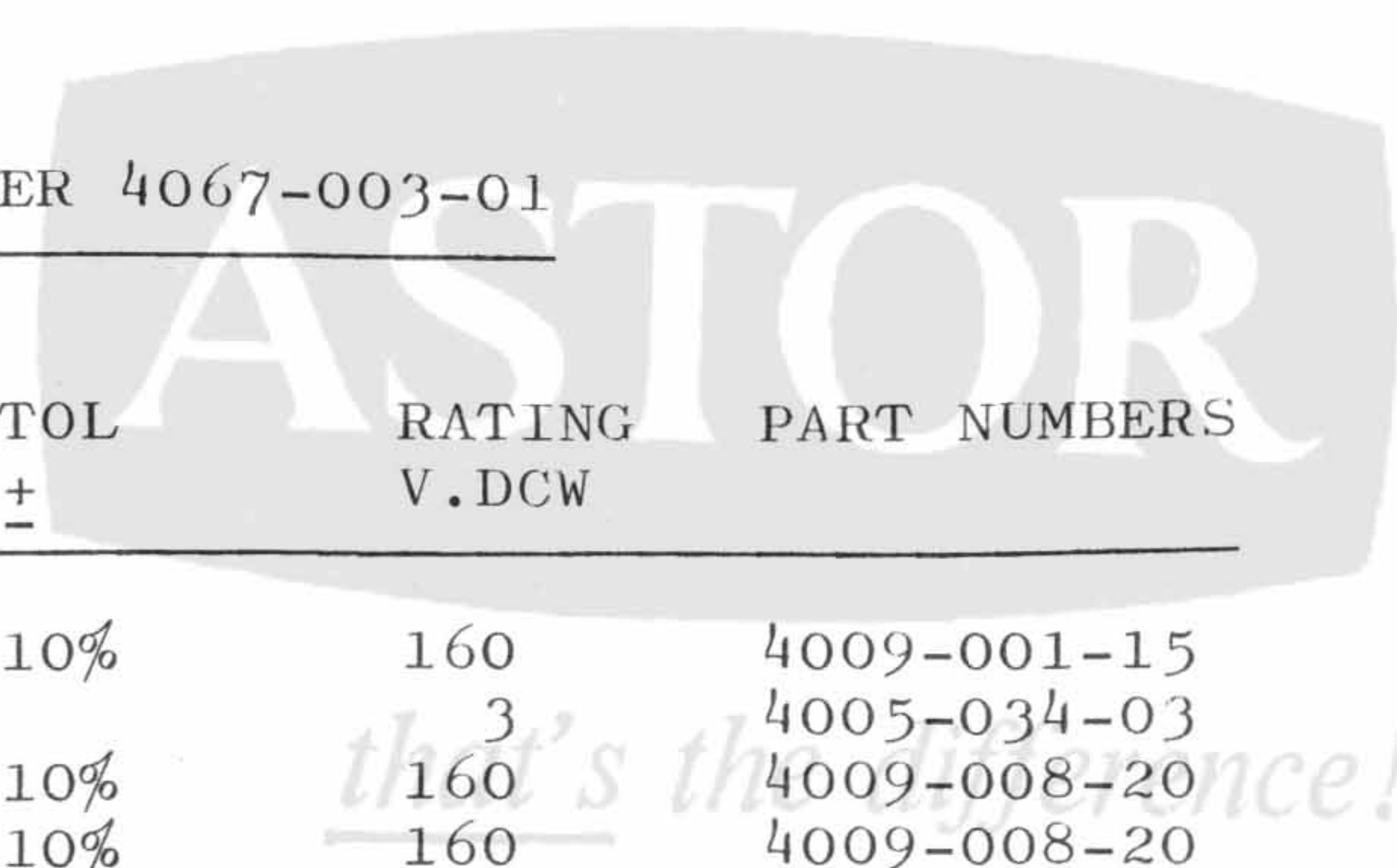

CIRCUIT NO	VALUE	CAPACITORS DESCRIPTION	TOL ±	RATING V.DCW	PART NUMBERS
1	.047uF	Polyester	10%	160	4009-001-15
2	3uF	Electrolytic		3	4005-034-03
3	.1uF	Polyester	10%	160	4009-008-20
4	.1uF	Polyester	10%	160	4009-008-20
5	5uF	Electrolytic		12	4005-018-13
6	50uF	Electrolytic		25	4005-001-18
7	.01uF	Polyester	10%	160	4009-014-17
8	.047uF	Polyester	10%	160	4009-001-15
9	560pF	Polysteyrene	10%	100	4004-026-03
10					
11	.0082uF	Polyester	10%	400	4009-029-03

CIRCUIT NO	VALUE OHMS	RESISTORS DESCRIPTION	TOL ±	RATING WATTS	PART NUMBER.
14	4.7M	Carbon	10%	1/2	4022-061-03
15	330K	Carbon	5%	1/2	4022-047-12
16	56K	Carbon	10%	1/2	4022-003-04
17	82K	Carbon	10%	1/2	4022-037-04
18	680K	Carbon	5%	1/2	4022-055-11
19	68K	Carbon	10%	1/2	4022-048-03
20					
21	470K	Carbon	10%	1/2	4022-045-03
22	47K	Carbon	10%	1/2	4022-051-03
23	680K	Carbon	5%	1/2	4022-055-11
24	220K	Carbon	5%	1/2	4022-063-13
25	22K	Carbon	10%	1/2	4022-026-02
26	1.5K	Carbon	10%	1/2	4022-007-01
27	10K	Carbon	10%	1/2	4022-004-01
28	47K	Carbon	10%	1/2	4022-051-03
29	12K	Carbon	10%	1/2	4022-029-01
30	8.2K	Carbon	10%	1/2	4022-027-01

CIRCUIT NO.	MISCELLANEOUS	PART NUMBER
33	Transistor - type BC 109 - Emitter Follower.	4128-077-01
34	Transistor - type BC 108 - Audio Amp.	4128-090-01

MECHANICAL

PART NUMBER	DESCRIPTION
7167-058-01	Pin (12) Circuit Board Terminations
7120-026-01	Insulator (4) glass, transistor mount.