

POWERED MULTIMEDIA SPEAKERS

YST-MS30/YST-MS35D

SERVICE MANUAL

IMPORTANT NOTICE

This manual has been provided for the use of authorized YAMAHA Retailers and their service personnel. It has been assumed that basic service procedures inherent to the industry, and more specifically YAMAHA Products, are already known and understood by the users, and have therefore not been restated.

WARNING: Failure to follow appropriate service and safety procedures when servicing this product may result in personal injury, destruction of expensive components, and failure of the product to perform as specified. For these reasons, we advise all YAMAHA product owners that any service required should be performed by an authorized YAMAHA Retailer or the appointed service representative.

IMPORTANT: The presentation or sale of this manual to any individual of firm does not constitute authorization, certification or recognition of any applicable technical capabilities, or establish a principle-agent relationship of any form.

The data provided is believed to be accurate and applicable to the unit(s) indicated on the cover. The research, engineering, and service departments of YAMAHA are continually striving to improve YAMAHA products. Modifications are, therefore, inevitable and specifications are subject to change without notice or obligation to retrofit. Should any discrepancy appear to exist, please contact the distributor's Service Division.

WARNING: Static discharges can destroy expensive components. Discharge any static electricity your body may have accumulated by grounding yourself to the ground buss in the unit (heavy gauge black wires connect to this buss).

IMPORTANT: Turn the unit OFF during disassembly and part replacement. Recheck all work before you apply power to the unit.

■ CONTENTS

TO SERVICE PERSONNEL	1	USB PORT OPERATION CHECK TEST	6~13
FRONT AND REAR PANELS	1~2	BLOCK DIAGRAM	14~15
SPECIFICATIONS	3~4	PRINTED CIRCUIT BOARD	16~17
INTERNAL VIEW	4	SCHEMATIC DIAGRAM	18
DISASSEMBLY PROCEDURES	5	PARTS LIST	19~27



このサービスマニュアルは、エコマーク認定の再生紙を使用しています。
This Service Manual uses recycled paper.



YST-MS30 YST-MS35D**■ TO SERVICE PERSONNEL**

1. Critical Components information.
Components having special characteristics are marked  and must be replaced with parts having specifications equal to those originally installed.
2. Leakage Current Measurement (For 120V Model only).
When service has been completed, it is imperative that you verify that all exposed conductive surfaces are properly insulated from supply circuits.

- Meter impedance should be equivalent to 1500 ohm shunted by 0.15 μ F.
- Leakage current must not exceed 0.5mA.
- Be sure to test for leakage with the AC plug in both polarities.

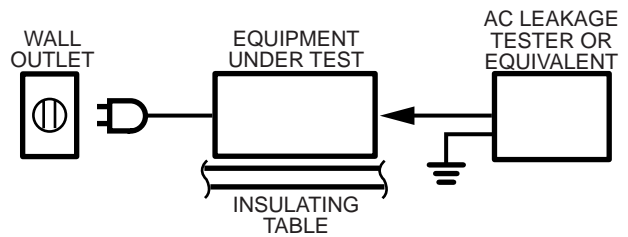
**WARNING: CHEMICAL CONTENT NOTICE!**

The solder used in the production of this product contains LEAD. In addition, other electrical/electronic and/or plastic (where applicable) components may also contain traces of chemicals found by the California Health and Welfare Agency (and possibly other entities) to cause cancer and/or birth defects or other reproductive harm.

DO NOT PLACE SOLDER, ELECTRICAL/ELECTRONIC OR PLASTIC COMPONENTS IN YOUR MOUTH FOR ANY REASON WHATSOEVER!

Avoid prolonged, unprotected contact between solder and your skin! When soldering, do not inhale solder fumes or expose eyes to solder/flux vapor!

If you come in contact with solder or components located inside the enclosure of this product, wash your hands before handling food.

■ FRONT AND REAR PANELS**● Satellite Speakers**

Left

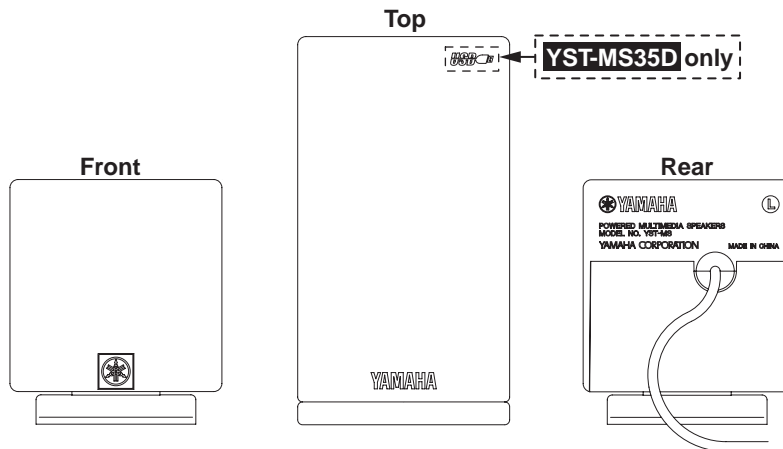

Right

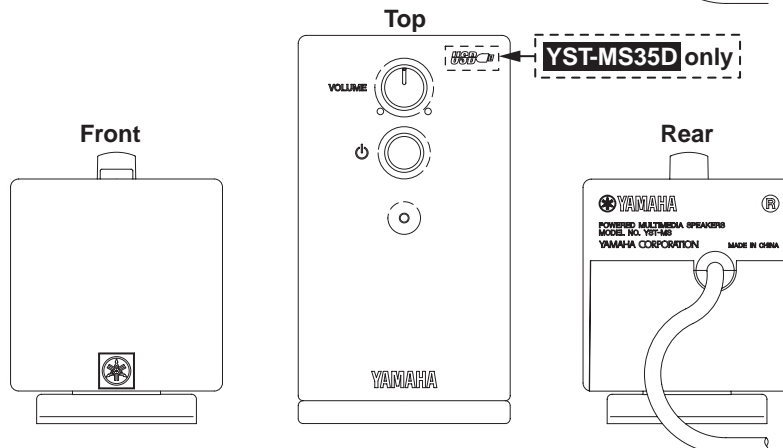

YST-MS30 YST-MS35D

● Subwoofer

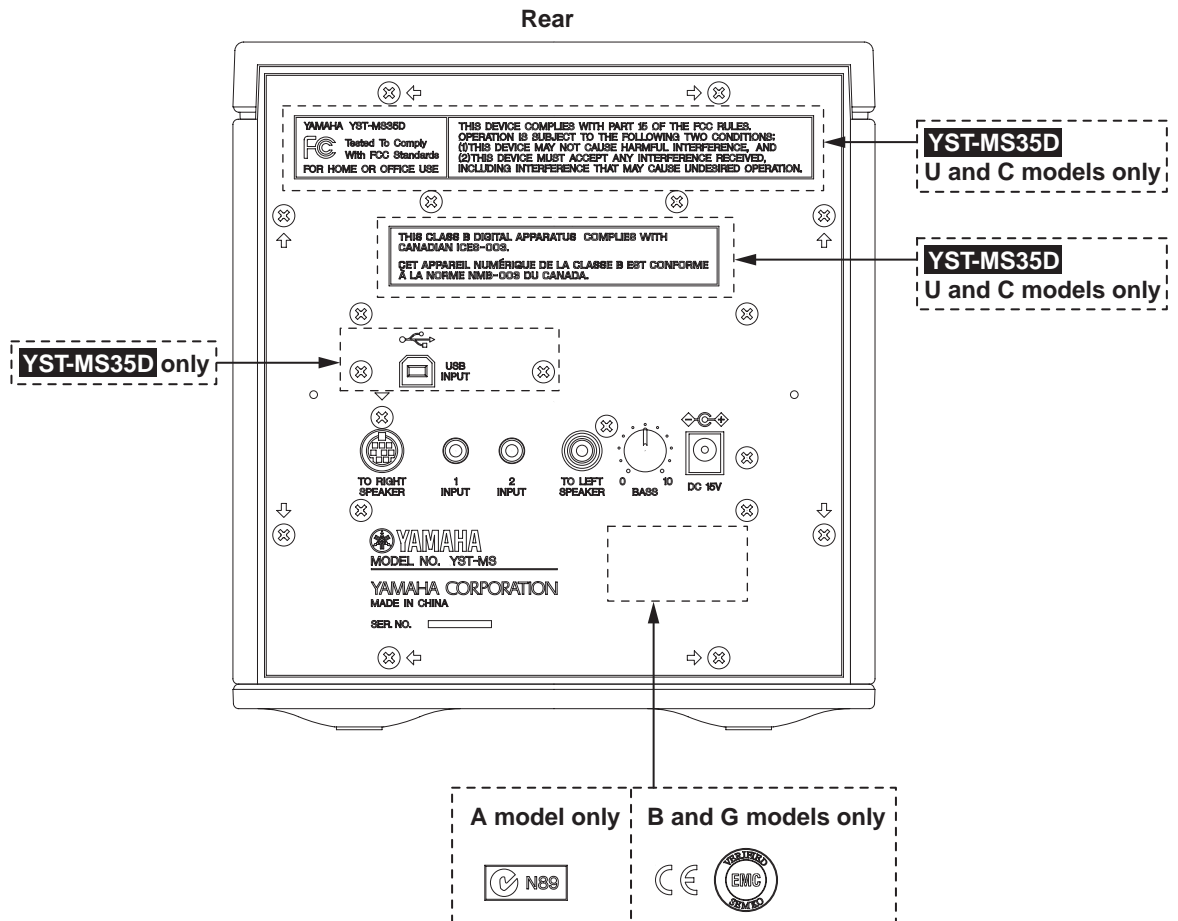
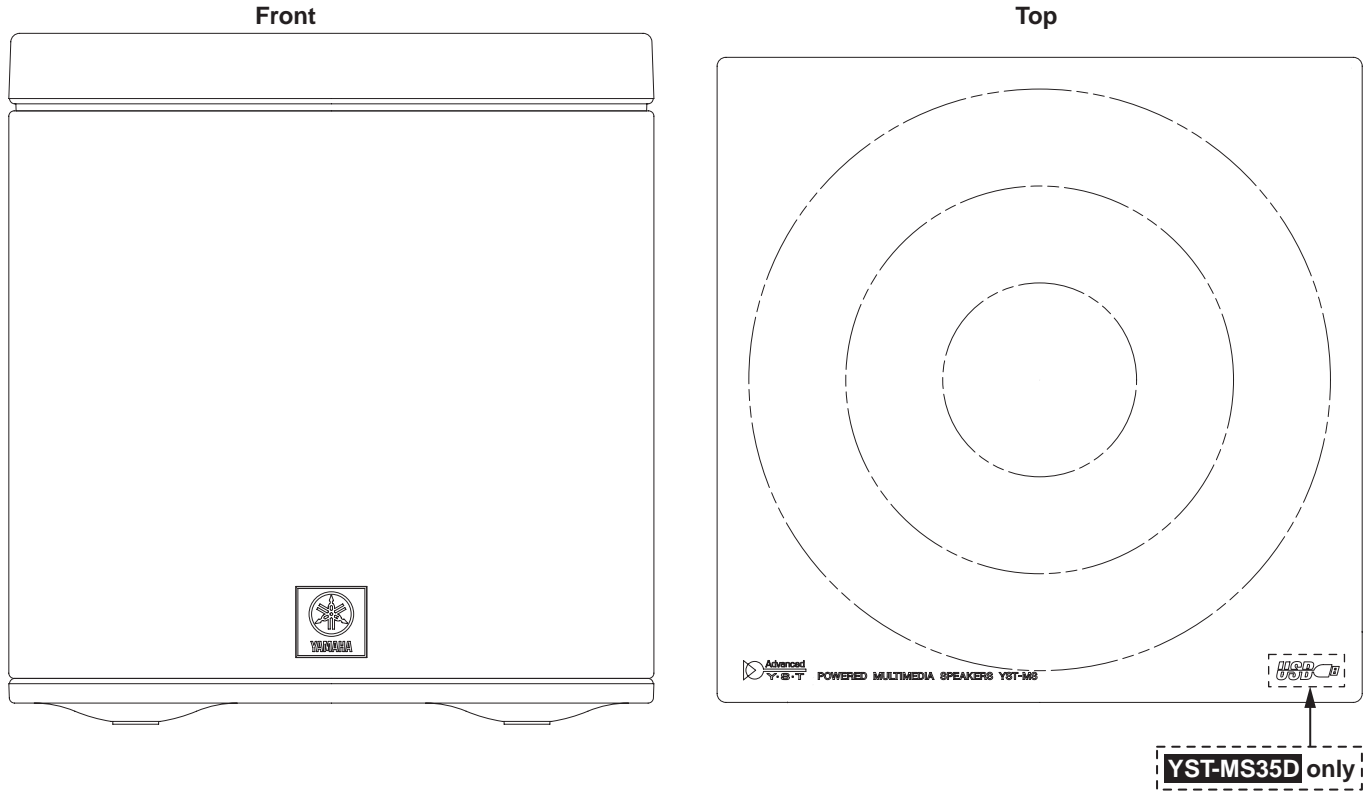

■ SPECIFICATIONS

Type Advanced Yamaha Active Servo Technology
(Advanced Y·S·T)

Output Power

Satellite 6W+6W (1kHz, 4 ohms at T.H.D.=10%)
Subwoofer 18W (100Hz, 4 ohms at T.H.D.=10%)

Input Sencitivity 200mV (1kHz, 4 ohms at 6W)

Input Impedance 20 kohms

Frequency Response

Satellite+Subwoofer 45Hz to 20kHz

Crossover Frequency

Satellite/Subwoofer fc=180Hz

Speaker Unit

Satellite : 5cm(2") cone (JA05U8),
Magnetic Shielding Type
Subwoofer: 12cm(5") cone (JA1286),
Magnetic Shielding Type

Input Sction

YST-MS30

Subwoofer 3.5mm stereo mini jack for audio-signal x2

YST-MS35D

Subwoofer 3.5mm stareo mini jack for audio-signal x2

Subwoofer USB digital x1

Output Sction

Subwoofer RCA pin jack connected to Left speaker
8 pin jack connected to Right speaker

Operating Section

Satellite  (standby/on)Switch
Volume control

Subwoofer Bass control

Power Supply(AC adapter)

U, C models AC120V/60Hz

A models AC240V/50Hz

B, G models AC230V/50Hz

Dimensions (W x H x D)

Satellite 65x75x119mm
(2.6"x3"x4.7")

Subwoofer 183x196x183mm
(7.2"x7.7"x7.2")

Weight

Satellite Left: 0.36kg (13 oz.)

Right: 0.45kg (1lbs.)

Subwoofer 2.3kg (5lbs. 1oz.)

Finish

YST-MS30

YST-MS30W Computer white color

YST-MS30B Black color

YST-MS35D

YST-MS35DW Computer white color

YST-MS35DB Black color

Accessories

YST-MS30

AC adapter (DC15V, 1.2A)x1

3.5mm stereo mini plug cable with black color(1.8m) x1

8 pcs of nonskid pads x1set

YST-MS35D

AC adapter (DC15V, 1.2A)x1

3.5mm stereo mini plug cable with black color(1.8m) x1

USB cable (2m) x1

8 pcs of nonskid pads x1set

CD-ROM x1

System Requirements YST-MS35D

OS: Microsoft Windows 98

CPU: 200 MHz or faster Intel Pentium MMX processor or equivalent

HDD: At least 10 MB available space

CD-ROM drive for driver installation

USB port compatible with USB standards ver 1.0

* Specifications subject to change without notice.

U U. S. A. model BBritish model

C Canadian model GEuropean model

A Australian model

Intel and Pentium are registered trademarks and MMX is a trademark of Intel Corporation.

Windows is a registered trademark of Microsoft Corporation in the United States and/or other countries.

All other trademarks are property of their respective owners.

YST-MS30 YST-MS35D

● DIMENSIONS

▼ Satellite Speaker

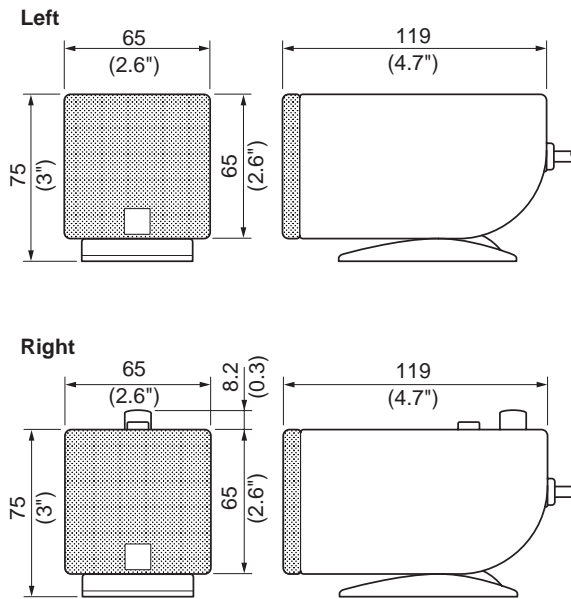

▼ Subwoofer

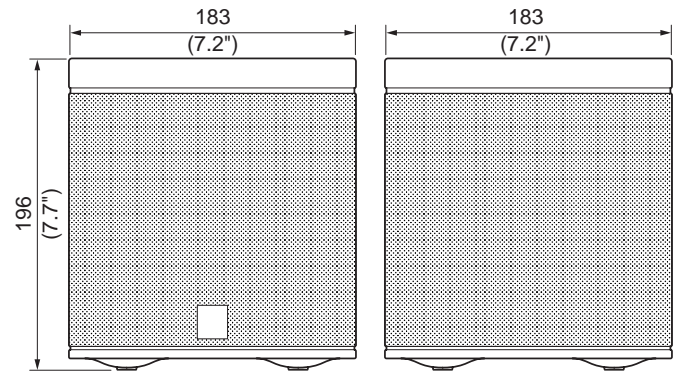

Units : mm (inch)

■ INTERNAL VIEW

● Satellite Speakers

Notes: The Satellite Speakers are available by the speaker unit (Left or Right).

Individual parts of the Satellite Speakers are not available. (See page 23 and 24 of the PARTS LIST for YST-MS30, page 25 and 26 of the PARTS LIST for YST-MS35D.)

▼ Left

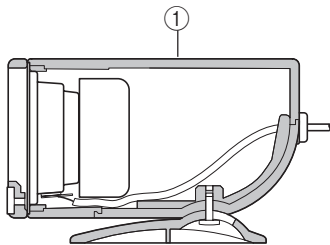

▼ Right

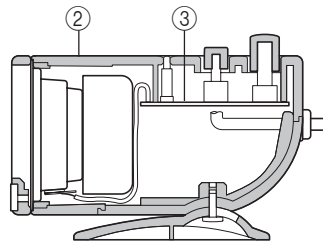

- ① Satellite Speaker Unit L
- ② Satellite Speaker Unit R
- ③ P. C. B. AMP (3)

● Subwoofer

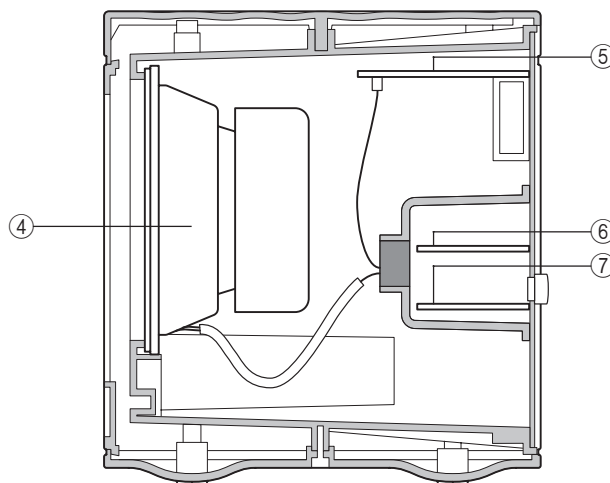

- ④ Speaker Unit
- ⑤ P. C. B. AMP (1)
- ⑥ P. C. B. AMP (4)
(YST-MS35D only)
- ⑦ P. C. B. MAIN (2)

DISASSEMBLY PROCEDURES

(Remove parts in disassembly order as numbered.)

Disassemble of the Subwoofer

1. Removal of the Rear Panel Ass'y.

- Remove 1 knob from the rear panel ass'y in Fig. 1.
- Remove 8 screws (①) in Fig. 1, and remove the rear panel ass'y from the cabinet ass'y.
- Disconnect the speaker cord in Fig. 1.

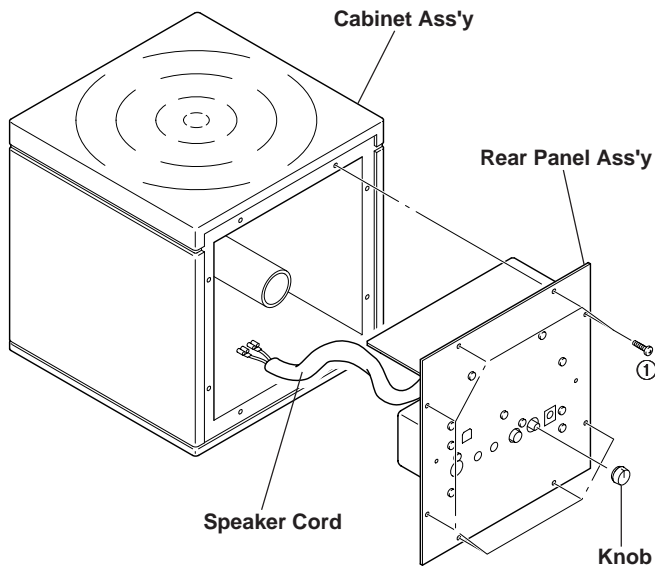

Fig. 1

2. Removal of the Speaker Unit

- Remove 4 screws (②) in Fig. 2, and remove the speaker unit from the cabinet ass'y.

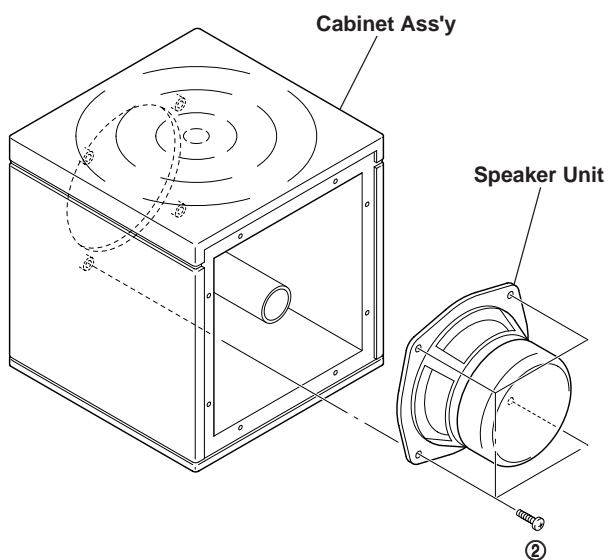

Fig. 2

3. Removal of the P. C. B. Ass'y

- Remove 2 screws (③) in Fig. 3, and remove the P. C. B. AMP (1) from the rear panel ass'y.
- Disconnect 2 connectors (CN1 and CN3) from the P. C. B. AMP (1) in Fig. 3.
- Remove 4 screws (④) in Fig. 3, and remove the mold case from the rear panel ass'y.
- Remove 3 screws (⑤) in Fig. 3, and remove the P. C. B. AMP (2) from the rear panel ass'y.

YST-MS35D only

- Remove 2 screws (⑥) in Fig. 3, and remove the P. C. B. AMP (4) from the rear panel ass'y.
- Disconnect 2 connectors (CN2 and CN5) from the P. C. B. AMP (4) in Fig. 3.

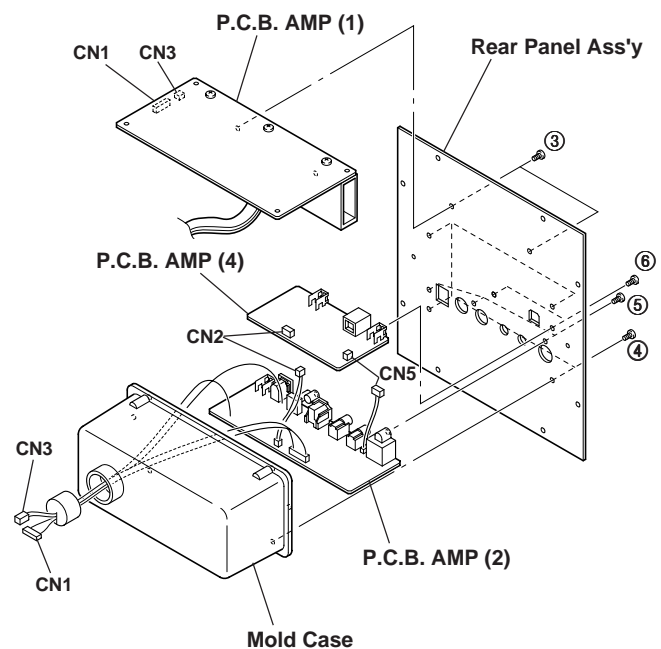

Fig. 3

YST-MS35D**■ USB PORT OPERATION CHECK TEST**

The YST-MS35D has a USB port. This USB port operation is checked be necessary whether or not normal state.

1. Installing and verifying the YST-MS35D speaker device drivers

Please follow these steps to install the Yamaha YST-MS35D speaker device drivers in your Windows 98 system using the included CD-ROM, and verify that Windows 98 recognizes the installed device drivers and that CD audio, sound generated while using software, and system sounds from the personal computer will be output via the USB port.

(1) Measuring instruments

- Personal Computer (Windows 98)
- CD-ROM (Accessory)
- USB Cable (Accessory)
- AC adapter (Accessory)

(2) System requirements

For digital audio streaming using a USB connection:

OS: Microsoft Windows 98

CPU: 200 MHz or faster Intel Pentium MMX processor or equivalent

HDD: At least 10 MB available space

CD-ROM drive for driver installation

USB port compatible with USB standards ver 1.0

(3) Installing the speaker device drivers**Notes:**

- **Do not connect the PC and the subwoofer using the USB cable before installing the YST-MS35D device drivers. If you accidentally connect them, refer to “(5) Re-installing the Device Driver” on page 8.**
- Before starting, check “(2) System Requirements” section, above, to see that your PC supports YST-MS35D.
- Make sure that no other CD-ROM is loaded in the CD-ROM drive and that you quit all application programs.
- Have your Windows 98 CD-ROM ready when you install the Yamaha YST-MS35D speaker device drivers. You may need it in some cases.
- The installation procedure may differ from the following instructions depending on the system environment. Follow the instructions that appear in the dialog box. Please contact your computer’s manufacturer or dealer if you have any questions.

- 1. Connect the YST-MS35D speakers and connect the AC adapter to the AC receptacle. At this time, do not connect the subwoofer to the computer using the USB cable.**
- 2. Turn on your PC and start Windows 98.**
- 3. Insert the YAMAHA YST-MS35D CD-ROM into the CD-ROM or DVD-ROM drive.**
If the Windows 98 Autorun feature is turned on, the installation start up screen appears automatically.
- 4. Continue with the installation as prompted.**
If the Windows 98 Autorun feature is not turned on, you must start the installation manually, as explained below.
- 5. Double-click the My Computer icon.**
The My Computer window opens.
- 6. Double-click the “Yamaha” CD-ROM icon.**
The installation start up screen appears.
- 7. Continue with the installation as prompted.**
- 8. After the installation is completed, connect the subwoofer to the computer using the USB cable.**

(4) Verifying the installation of device drivers

After you have installed the device drivers as explained in the previous section, follow the steps below to verify that Windows 98 recognizes these drivers.

1. Select "Start," then select "Settings-->Control Panel" from the menu.
2. Double-click "System" in the control Panel to display the "System Properties" panel, select the "Device Manager" tab, then select "View devices by type."
3. Click the plus sign (+) for "Human Interface Devices," "Sound, video and game controllers," and "Universal Serial Bus Controller" in the device list, and check to see if "Human Interface Devices," "YAMAHA YST-MS35D USB Audio," and "YAMAHA YST-MS35D USB Composite Device" as shown below.

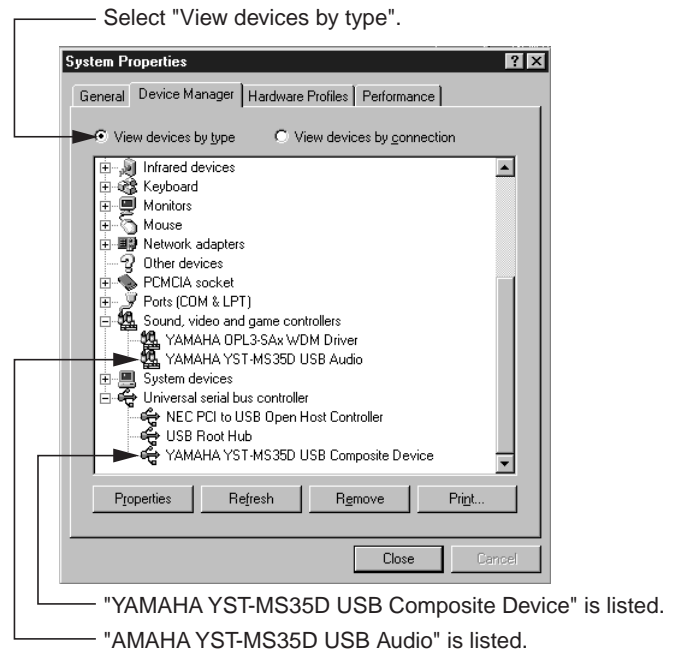
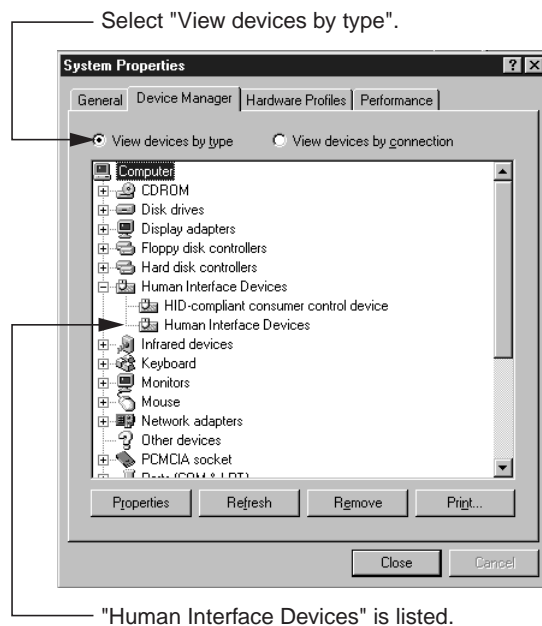

- The contents of the list on the display shown above may vary depending on the system environment.

Note: If an exclamation point (!), or a question mark (?) appears to the left of the USB device name, check the following:

1. Make sure that you have installed the drivers from the included CD-ROM.
2. Check to see if the USB cable is connected securely.
3. The AC adapter plug is connected to the AC receptacle.

YST-MS35D

(5) Re-installing the Device Driver

If you connect the PC and the YST-MS35D via the USB ports using the USB cable before you install the included application software, the YST-MS35D device driver will not recognize the devices correctly, and will display the following items in the “System Properties” window:

- USB Audio Device in the list of “Sound, video and game controllers”
- USB Composite Device in the list of “Universal serial bus controller”

To recognize the devices correctly, re-install the driver following the steps below:

1. Make sure the YST-MS35D is connected to the PC via the USB cable.
2. Click the “+” symbol next to “Universal serial bus controller” to display the list.
3. Make sure that “USB Composite Device” appears in the list and click to select it.

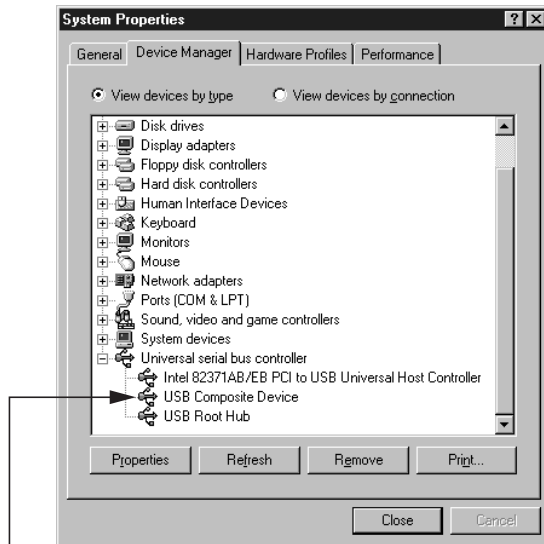

“USB Composite Device” is listed.

4. Click [Remove].

The dialog shown below appears. Click [OK].

“USB Audio Device” will be deleted.



5. Make sure that “USB Composite Device” has been deleted from the list of “Universal serial bus controller.”

6. Disconnect the USB cable.

7. Insert the included CD-ROM into the CD-ROM drive and re-install the device driver.

8. Check the device driver. Refer to “(4) Verifying the installation of device drivers” on page 7.

(6) Ensuring the output of audio data from the USB port

Follow the steps below to ensure that the USB port on your computer is ready to output CD audio.

1. Select “Start,” then select “Settings-->Control Panel” from the menu.

2. Double-click “Multimedia” icon in the Control Panel to display the “Multimedia Properties” window, and under “Playback” in the “Audio” tab, make sure that “YAMAHA YST-MS35D USB Audio” is selected as the “Preferred device.”

(Depending on the computer, if multiple USB audio devices are connected, the number of devices may appear in parentheses.)

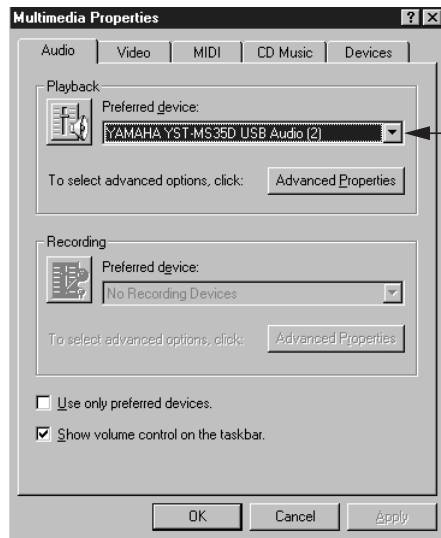

“YAMAHA YST-MS35D USB Audio” selected as Preferred device

- The contents of the list on the display shown at left may vary depending on the system environment.

3. Select the “CD Music” tab, make sure that the text below the “CD Music Volume” is Active, and check “Enable digital CD audio for this CD-ROM device.”

If the text below “CD Music Volume” appears in gray, you cannot check the “Enable digital CD audio for this CD-ROM device” box. In this case, your CD-ROM drive may not be supported. Consult your computer manufacturer or dealer.

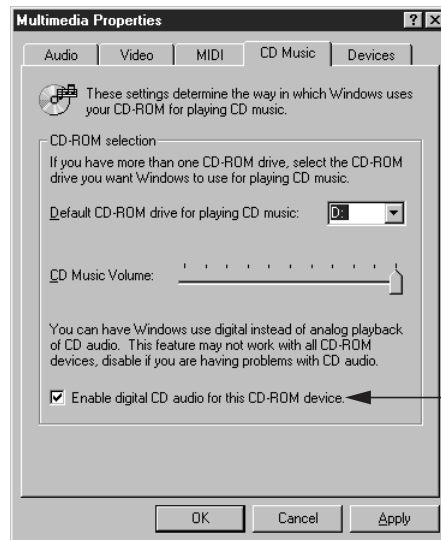

Enable digital CD audio for this CD-ROM device

- The contents of the list on the display shown at left may vary depending on the system environment.

Now you are ready to enjoy your YST-MS35D Speaker System!

YST-MS35D

2. STARTING THE USB PORT OPERATION CHECK TEST

The USB port operation check test is using the tool for check test "USB Check Version X.X".

(1) Downloading the tool for check test

Please follow these steps to download the tool for check test in your PC from the homepage of "USB".

1. Access to the URL "<http://www.usb.org/developers/index.html>".
2. "developers" of "USB" homepage will be displayed.
3. Click "Tools" from the menu of "developers".
4. Click "USBComp.exe" from the menu of "Tools".
5. After the file unzips and "USB Check" file, "Hidview" file, and all needed drivers appear.
6. Make sure that "USB Check" file appears and click to select it.
7. After the downloaded, running the tool for check test "USB Check Version X.X".

(2) Starting the check test

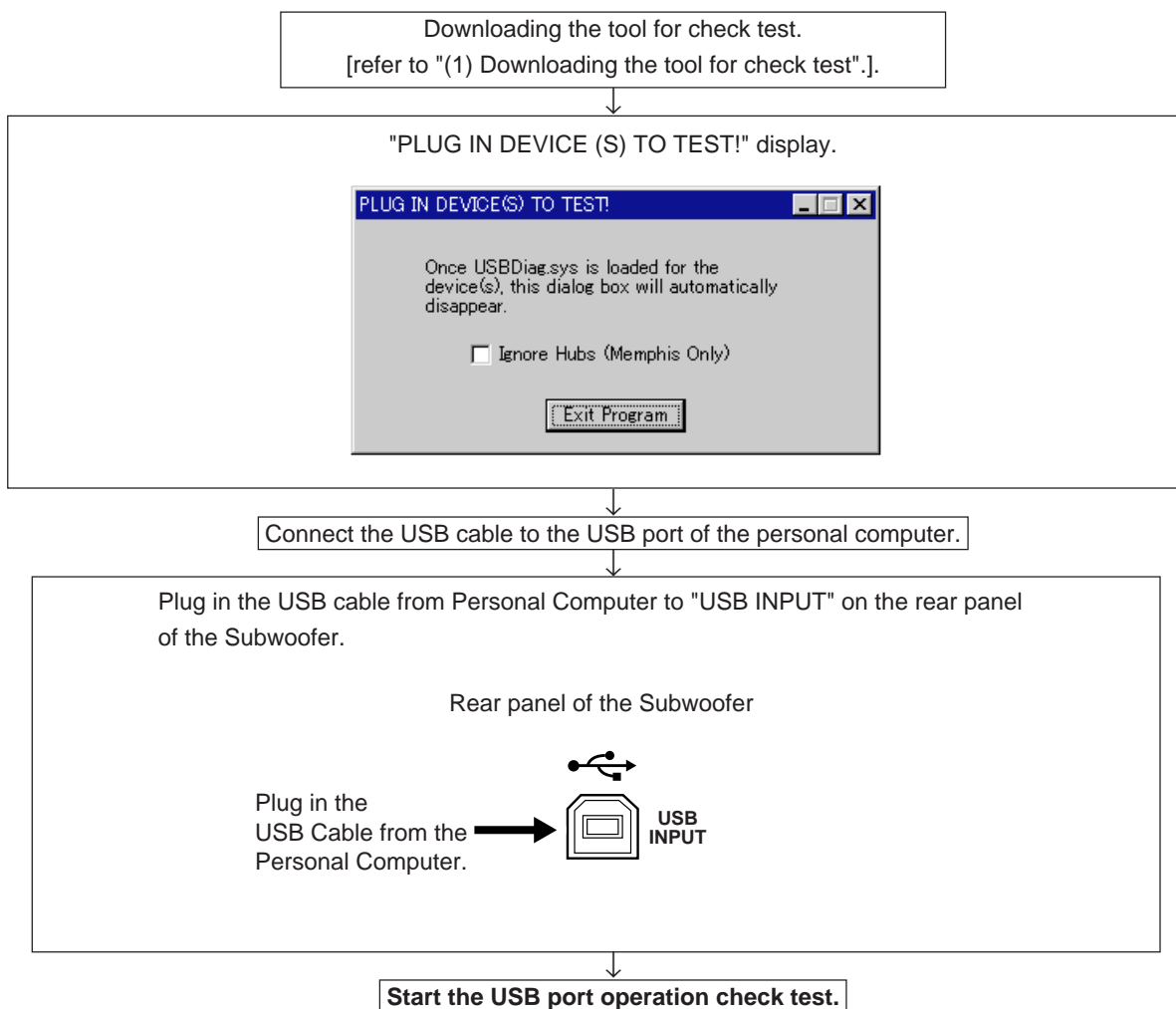

YST-MS35D**3. DETAIL OF USB PORT OPERATION CHECK TEST**

There are 5 items in the USB port operation check test as shown below.

TEST 1 " 00Vid (0X0499) Pid (0X3002) "

"USB Compliance Tool, Version 2.6" display.

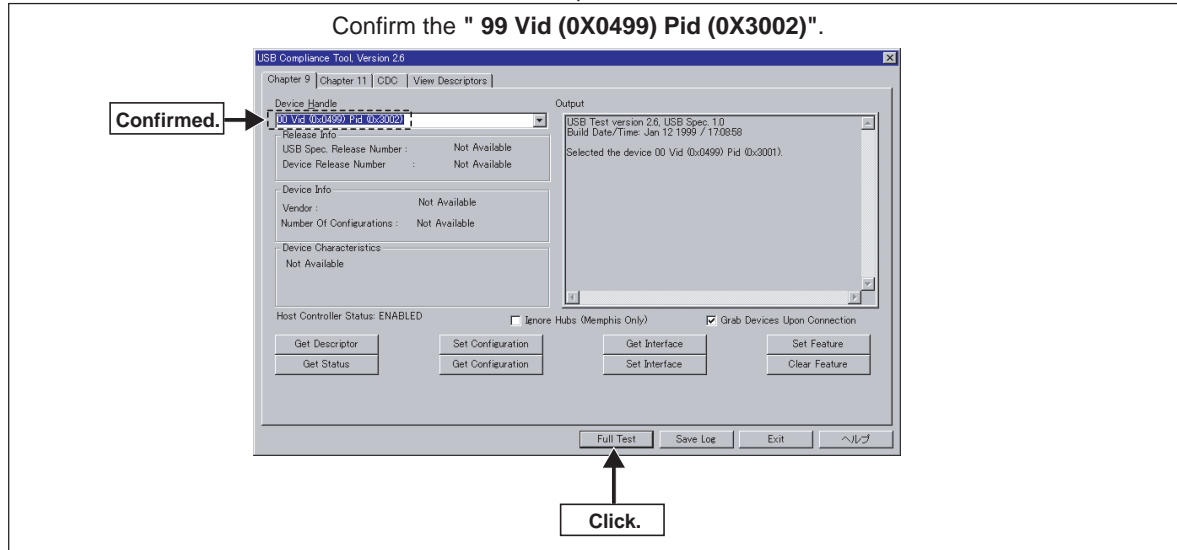

Confirmation of USB EEPROM (IC201) operation is completed.

Click the "Full Test" for next test.

YST-MS35D

TEST 2 All is checked ("✓").

"USB Chapter 9 Test" display.

Confirm that all is checked ("✓").

Confirmed.

Click.

Click the "Start Automated Testing" for next test.

TEST 3 " Error Count : 0 "

"Full Test Results" display.

Confirm the " Error Count : 0 ".

Confirmed.

Operation of between USB IC and USB port is normal state.

Enter automated to next test.

YST-MS35D

TEST 4 " OK "

"USB Compliance Tool" display.

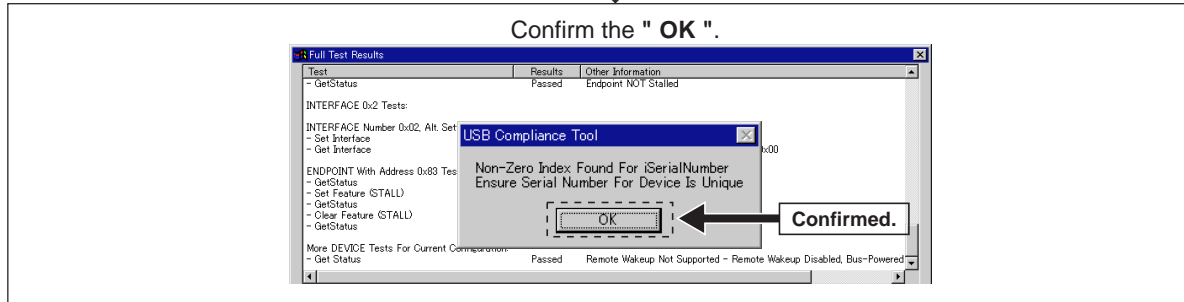

Enter automated to next test.

TEST 5 " OK "

"DEVICE IS HID" display.

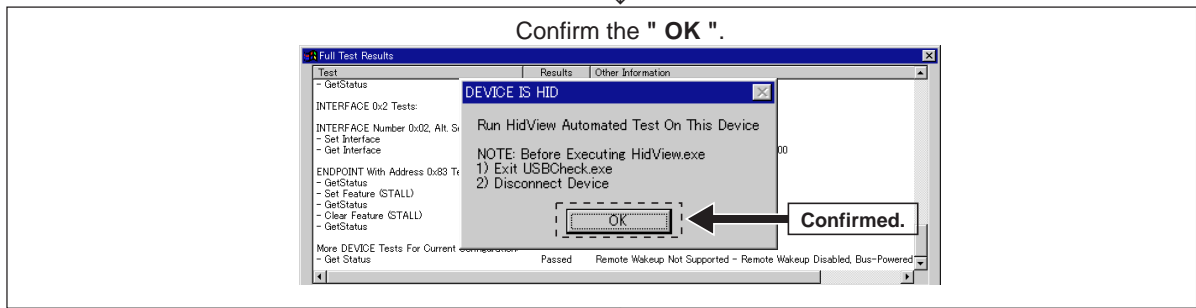

Completed the USB port operation check test.

PRINTED CIRCUIT BOARD (Foil side)

Semiconductor Location

Ref. No.	Location
D2	D5
D3	C1
D4	D2
D5	C2
D6	C2
D7	C2
D201	C3
IC1	C5
IC2	E1
IC3	C5
IC4	D2
IC5	D5
IC6	D2
IC7	C2
IC8	C2
IC201	C3
IC202	C3
Q1	G2
Q2	G2
Q3	D5
Q4	C1
Q5	D1
Q6	C1
Q201	C4

Subwoofer

P.C.B. AMP(1)

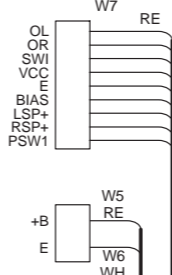
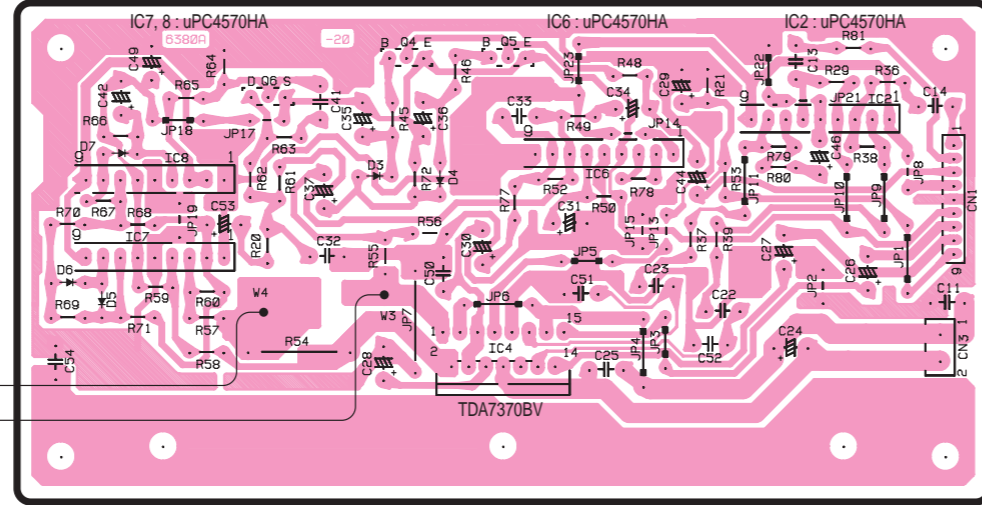
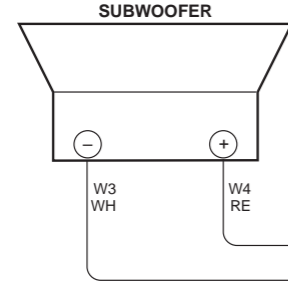

USB INPUT

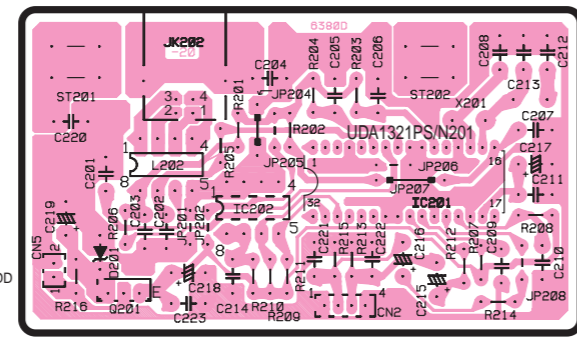

P.C.B. AMP(4)

YST-MS35D only

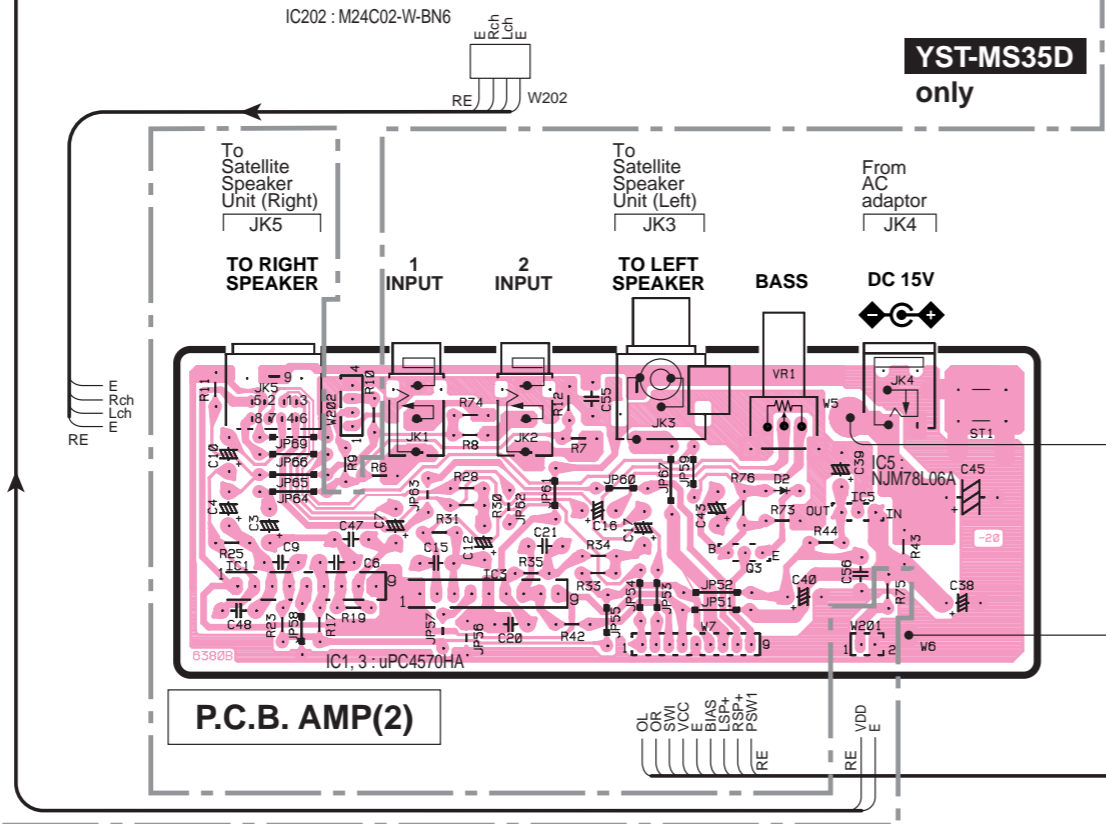

P.C.B. AMP(2)

Satellite Speakers

Satellite Speaker Unit (Right)

P.C.B. AMP(3)

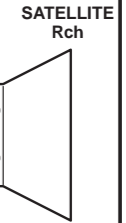
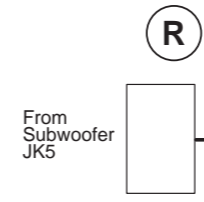
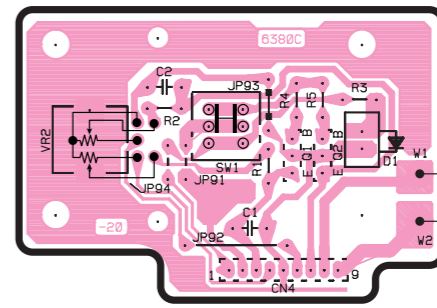

Satellite Speaker Unit (Left)

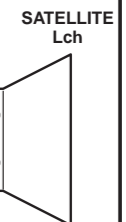

SCHEMATIC DIAGRAM

Subwoofer

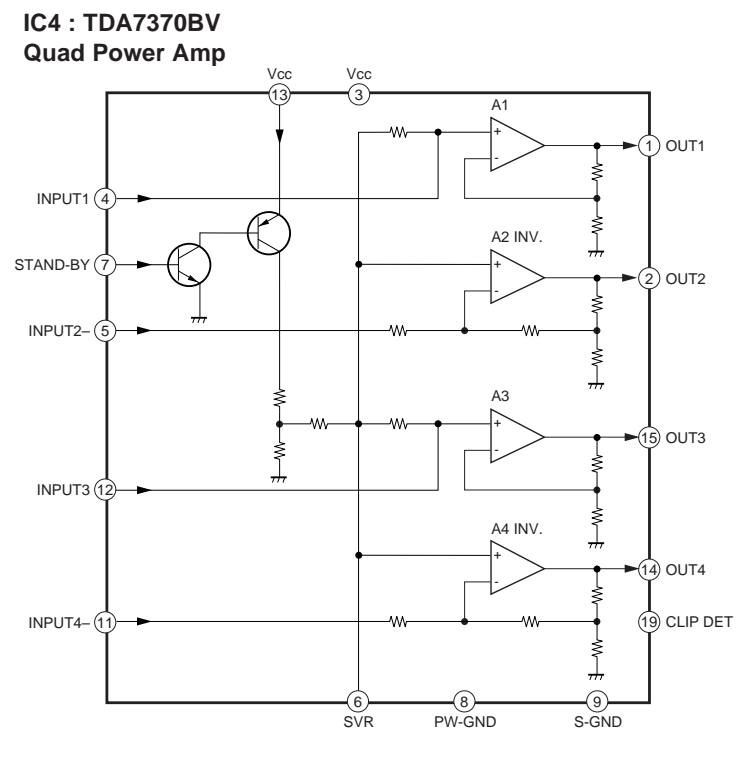
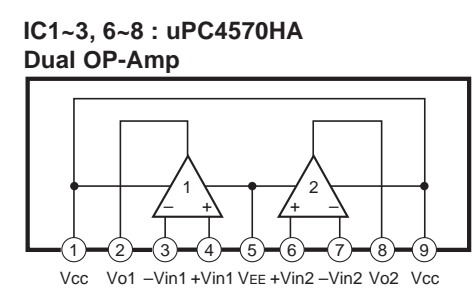
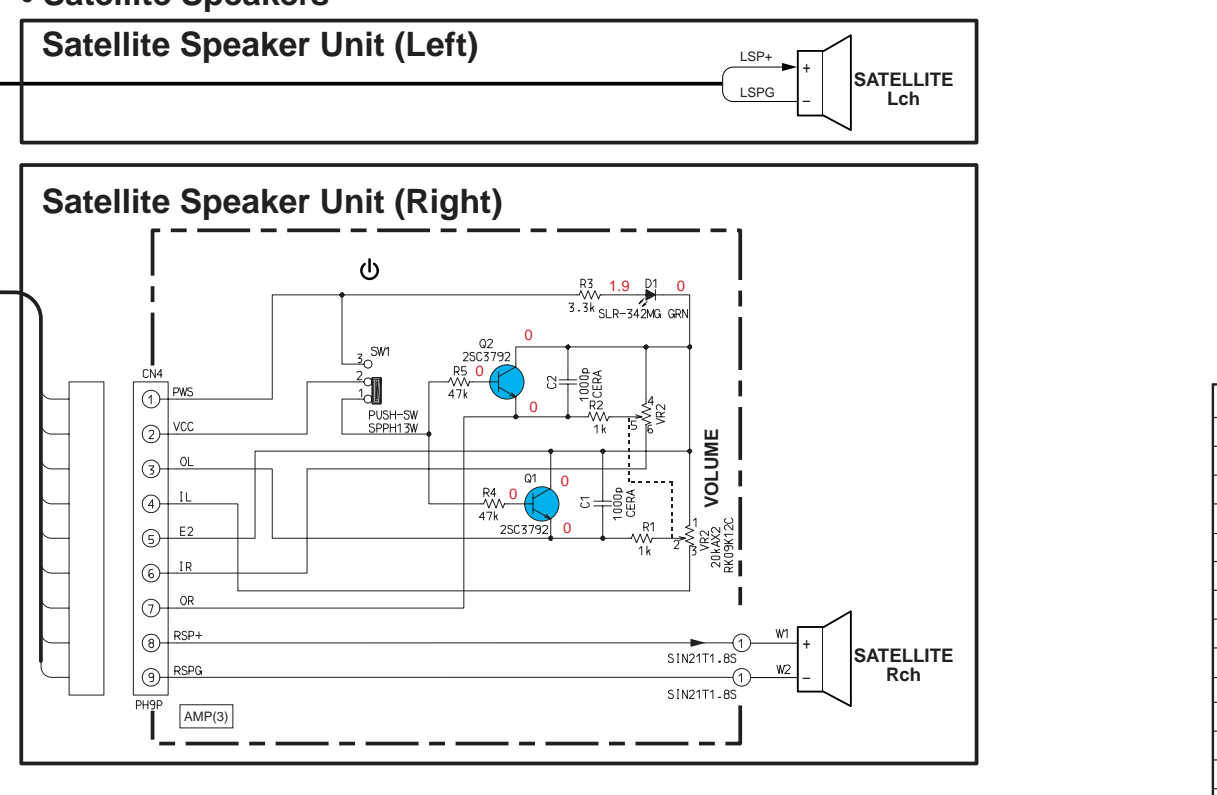
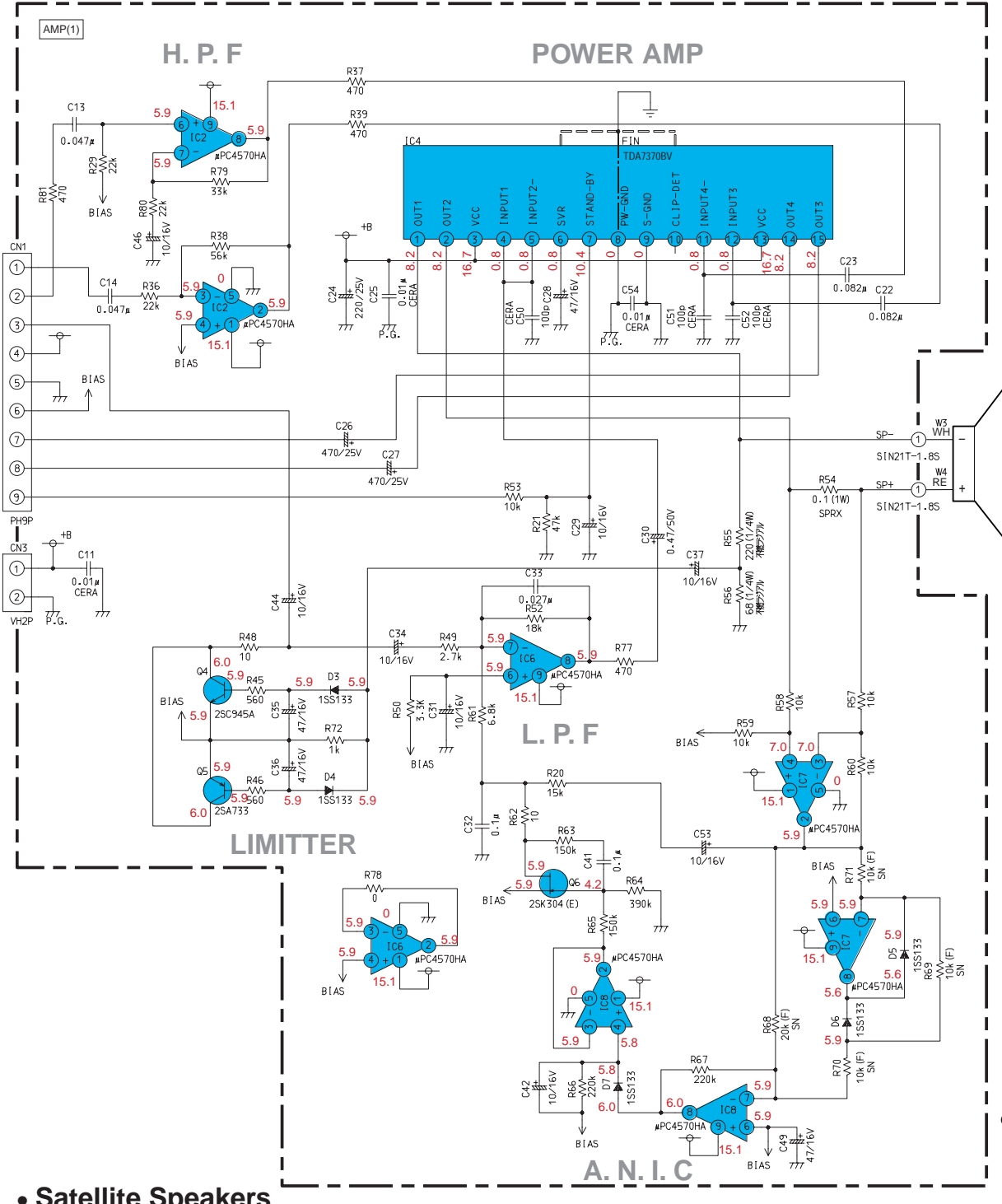
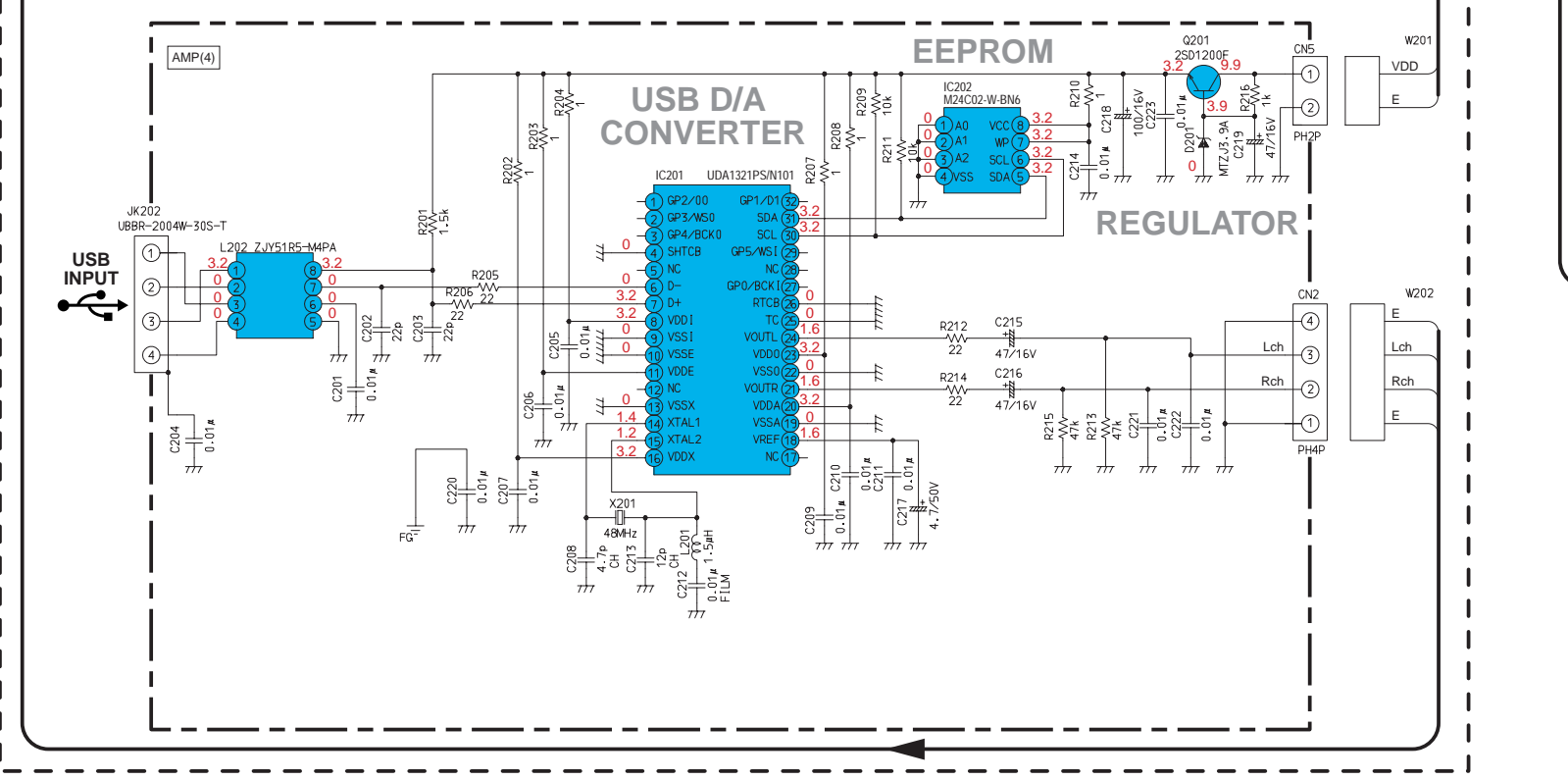
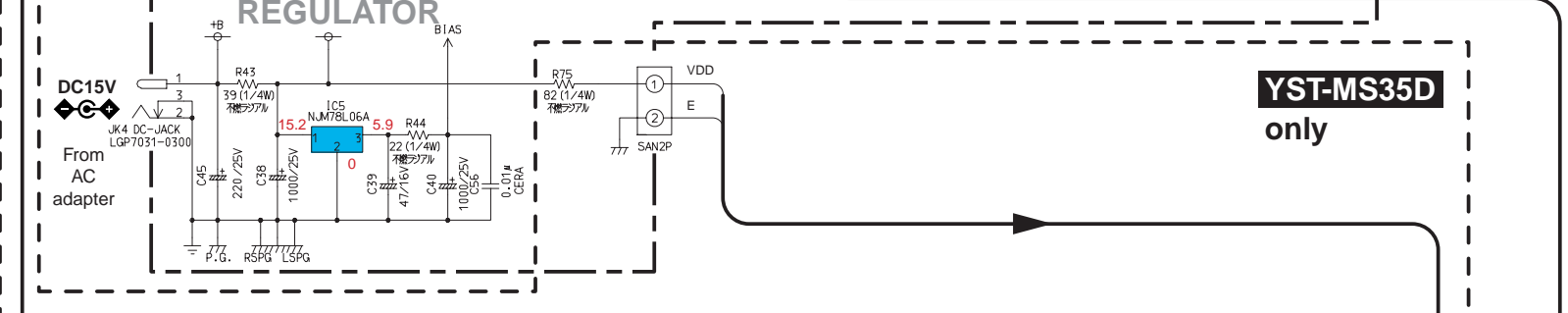
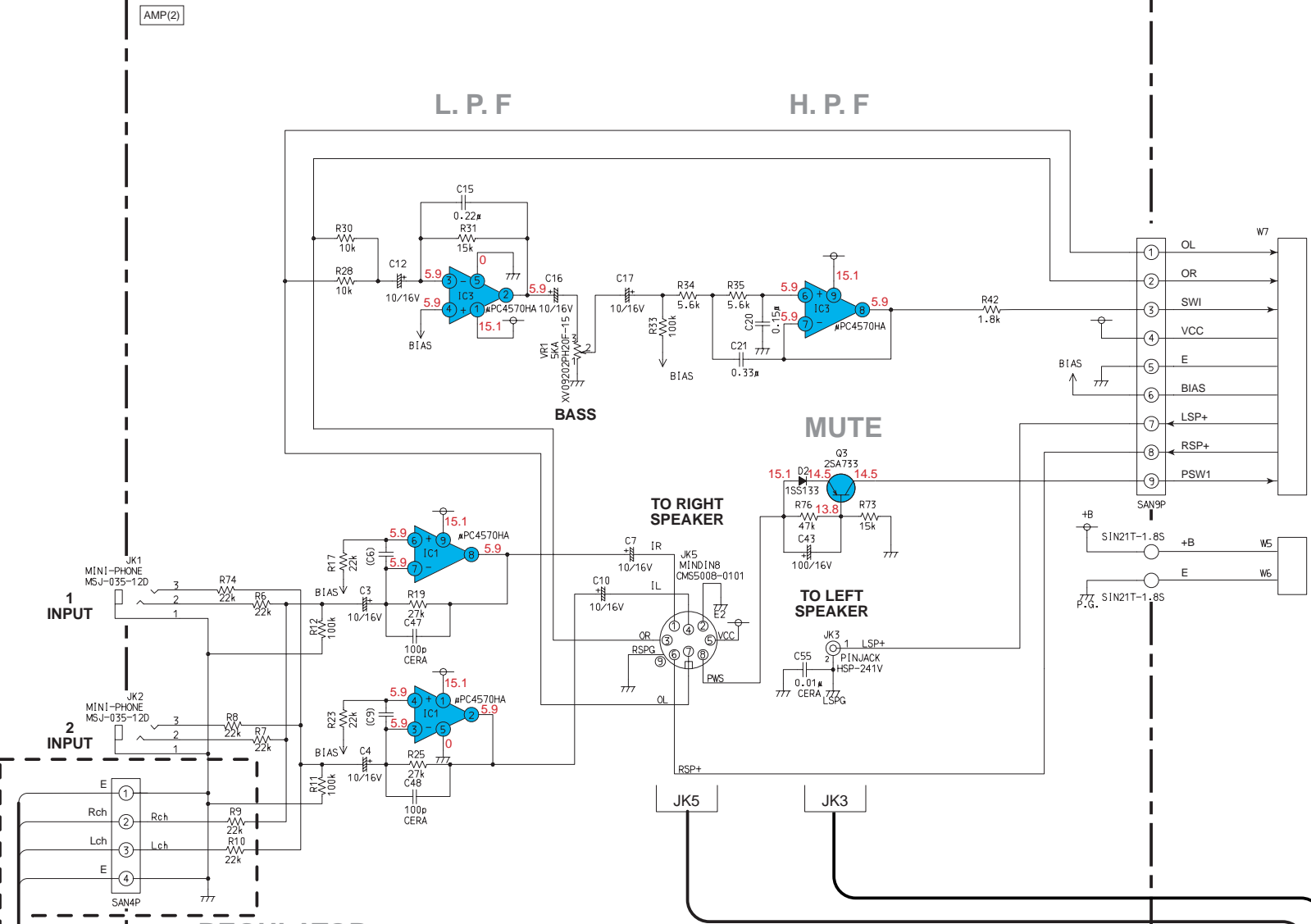

YST-MS35D only

IC201: UDA1321PS/N101 Universal Serial Bus (USB) Digital-to-Analog Converter (DAC)

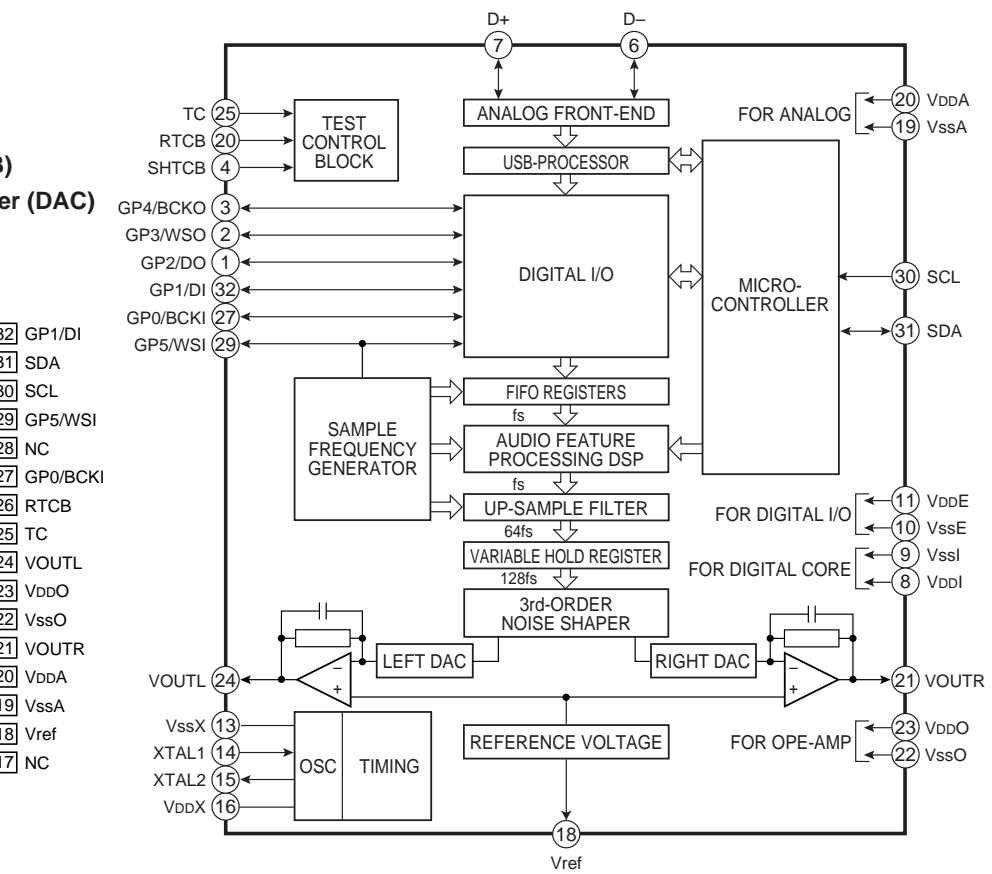
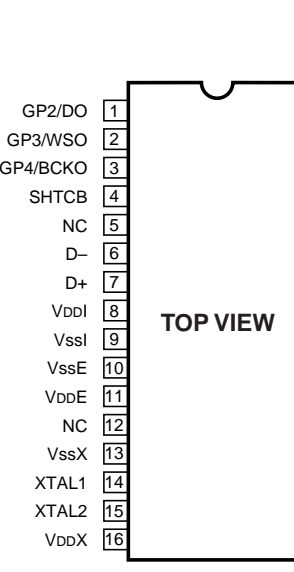

No.	Name	I/O	Function	No.	Name	I/O	Function
1	GP2/DO	+1		32	GP1/DI	+1	
2	GP3/WSO	+1		31	SDA	I/O	Serial data (I ² C-Bus)
3	GP4/BCKO	+1		30	SCL	I	Serial clock (I ² C-Bus)
4	SHTCB	+2		29	GP5/WSI	+1	
5	NC	Unconnected		28	NC	Unconnected	
6	D-	I/O	Negative Data line of the differential data bus common to the USB-standard.	27	GP0/BCKI	+1	
7	D+	I/O	Positive Data line of the differential data bus common to the USB-standard.	26	RTCB	+2	
8	VDDI	Power supply	(for digital core)	25	TC	+2	
9	VSSI	Ground	(for digital I/O)	24	VOULT	O	Lch Output voltage
10	VDDO	Power supply	(for OPE-AMP.)	23	VbDO	Power supply	
11	VSSO	Ground		22	VSSO	Ground	
12	NC	Unconnected		21	VOUTR	O	Rch output voltage
13	VSSX	Ground		20	VbOX	Power supply	
14	XTAL1	Input	(for Crystal oscillator)	19	VSSA	Ground	
15	XTAL2	Output		18	Vref	O	Reference Voltage
16	VDDX	Power supply		17	NC	Unconnected	

NOTE) +1 : Normally unconnected. +2 : Normally connected to ground.

YST-MS35D only

IC202: M24C02-W-BN6 2k 2.5V CMOS Serial Electrically Erasable PROM (EEPROM)

No.	Name	I/O	Function	No.	Name	I/O	Function
1	A0	+1		8	Vcc	Power supply	
2	A1	+1		7	WP	+2	
3	A2	+1		6	SCL	O	Serial clock (I ² C-Bus)
4	Vss	Ground		5	SDA	I/O	Serial data (I ² C-Bus)

NOTE) +1 : Normally connected to ground. +2 : Normally connected to power supply.

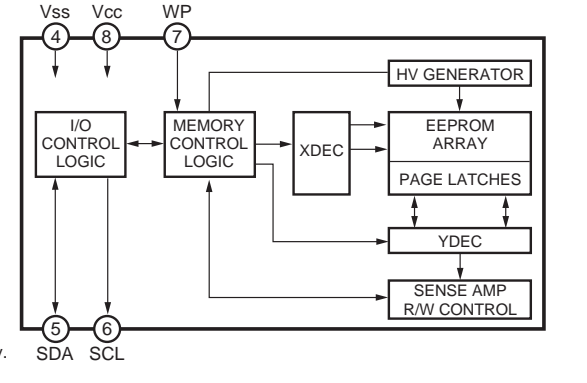

* All voltages are measured with a 10MQ/V DC electric volt meter.
 * Components having special characteristics are marked Δ and must be replaced with parts having specifications equal to those originally installed.
 * Schematic diagram is subject to change without notice.

PIN CONNECTION DIAGRAM OF DIODES, TRANSISTORS AND IC's.

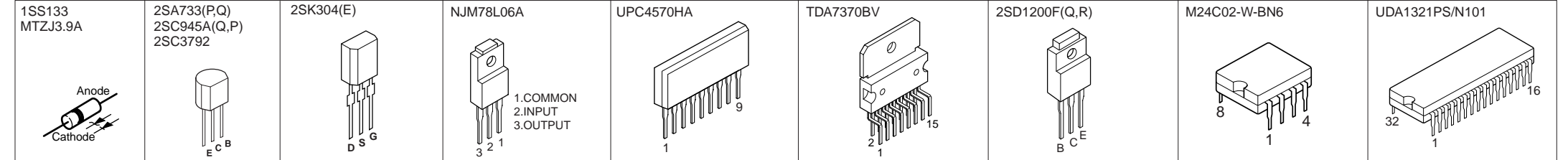

PARTS LIST

■ ELECTRICAL PARTS

■ WARNING

Components having special characteristics are marked \triangle and must be replaced with parts having specifications equal to those originally installed.

- Carbon resistors (1/6W or 1/4W) are not included in the ELECTRICAL PARTS List. For the parts Nos. of the carbon resistores, refer to the last page.

ABBREVIATIONS IN THIS LIST ARE AS FOLLOWS:

C. A. EL. CHP	: CHIP ALUMI. ELECTROLYTIC CAP	L. EMIT	: LIGHT EMITTING MODULE
C. CE	: CERAMIC CAP	LED. DSPLY	: LED DISPLAY
C. CE. ARRAY	: CERAMIC CAP ARRAY	LED. INFRD	: LED, INFRARED
C. CE. CHP	: CHIP CERAMIC CAP	MODUL. RF	: MODULATOR, RF
C. CE. ML	: MULTILAYER CERAMIC CAP	PHOT. CPL	: PHOTO COUPLER
C. CE. M. CHP	: CHIP MULTILAYER CERAMIC CAP	PHOT. INTR	: PHOTO INTERRUPTER
C. CE. SAFTY	: RECOGNIZED CERAMIC CAP	PHOT. RFLCT	: PHOTO REFLECTOR
C. CE. TUBLR	: CERAMIC TUBULAR CAP	PIN. TEST	: PIN, TEST POINT
C. CE. SMI	: SEMI CONDUCTIVE CERAMIC CAP	PLST. RIVET	: PLASTIC RIVET
C. EL	: ELECTROLYTIC CAP	R. ARRAY	: RESISTOR ARRAY
C. MICA	: MICA CAP	R. CAR	: CARBON RESISTOR
C. ML. FLM	: MULTILAYER FILM CAP	R. CAR. CHP	: CHIP RESISTOR
C. MP	: METALLIZED PAPER CAP	R. CAR.FP	: FLAME PROOF CARBON RESISTOR
C. MYLAR	: MYLAR FILM CAP	R. FUS	: FUSABLE RESISTOR
C. MYLAR. ML	: MULTILAYER MYLAR FILM CAP	R. MTL. CHP	: CHIP METAL FILM RESISTOR
C. PAPER	: PAPER CAPACITOR	R. MTL. FILM	: METAL FILM RESISTOR
C. PLS	: POLYSTYRENE FILM CAP	R. MTL. OXD	: METAL OXIDE FILM RESISTOR
C. POL	: POLYESTER FILM CAP	R. MTL. PLAT	: METAL PLATE RESISTOR
C. POLY	: POLYETHYLENE FILM CAP	RSNR. CE	: CERAMIC RESONATOR
C. PP	: POLYPROPYLENE FILM CAP	RSNR. CRYST	: CRYSTAL RESONATOR
C. TNL	: TANTALUM CAP	R. TW. CEM	: TWIN CEMENT FIXED RESISTOR
C. TNT. CHP	: CHIP TANTALUM CAP	R. WW	: WIRE WOUND RESISTOR
C. TRIM	: TRIMMER CAP	SCR. BND. HD	: BIND HEAD B-TITE SCREW
CN	: CONNECTOR	SCR. BW. HD	: BW HEAD TAPPING SCREW
CN. BS. PIN	: CONNECTOR, BASE PIN	SCR. CUP	: CUP TITE SCREW
CN. CANNON	: CONNECTOR, CANNON	SCR. TERM	: SCREW TERMINAL
CN. DIN	: CONNECTOR, DIN	SCR. TR	: SCREW, TRANSISTOR
CN. FLAT	: CONNECTOR, FLAT CABLE	SUPRT. PCB	: SUPPORT, P. C. B.
CN. POST	: CONNECTOR, BASE POST	SURG. PRTCT	: SURGE PROTECTOR
COIL. MX. AM	: COIL, AM MIX	SW. TACT	: TACT SWITCH
COIL. AT. FM	: COIL, FM ANTENNA	SW. LEAF	: LEAF SWITCH
COIL. DT. FM	: COIL, FM DETECT	SW. LEVER	: LEVER SWITCH
COIL. MX. FM	: COIL, FM MIX	SW. MICRO	: MICRO SWITCH
COIL. OUTPT	: OUTPUT COIL	SW. PUSH	: PUSH SWITCH
DIOD. ARRAY	: DIODE ARRAY	SW. RT. ENC	: ROTARY ENCODER
DIODE. BRG	: DIODE BRIDGE	SW. RT. MTR	: ROTARY SWITCH WITH MOTOR
DIODE. CHP	: CHIP DIODE	SW. RT	: ROTARY SWITCH
DIODE. VAR	: VARACTOR DIODE	SW. SLIDE	: SLIDE SWITCH
DIOD. Z. CHP	: CHIP ZENER DIODE	TERM. SP	: SPEAKER TERMINAL
DIODE. ZENR	: ZENER DIODE	TERM. WRAP	: WRAPPING TERMINAL
DSCR. CE	: CERAMIC DISCRIMINATOR	THRMST. CHP	: CHIP THERMISTOR
FER. BEAD	: FERRITE BEADS	TR. CHP	: CHIP TRANSISTOR
FER. CORE	: FERRITE CORE	TR. DGT	: DIGITAL TRANSISTOR
FET. CHP	: CHIP FET	TR. DGT. CHP	: CHIP DIGITAL TRANSISTOR
FL. DSPLY	: FLUORESCENT DISPLAY	TRANS	: TRANSFORMER
FLTR. CE	: CERAMIC FILTER	TRANS. PULS	: PULSE TRANSFRMER
FLTR. COMB	: COMB FILTER MODULE	TRANS. PWR	: POWER TRANSFORMER ASS'y
FLTR. LC. RF	: LC FILTER, EMI	TUNER. AM	: TUNER PACK, AM
GND. MTL	: GROUND PLATE	TUNER. FM	: TUNER PACK, FM
GND. TERM	: GROUND TERMINAL	TUNER. PK	: FRONT-END TUNER PACK
HOLDER. FUS	: FUSE HOLDER	VR	: ROTARY POTENTIOMETER
IC. PRTCT	: IC PROTECTOR	VR. MTR	: POTENTIOMETER WITH MOTOR
JUMPER. CN	: JUMPER CONNECTOR	VR. SW	: POTENTIOMETER WITH ROTARY SW
JUMPER. TST	: JUMPER, TEST POINT	VR. SLIDE	: SLIDE POTENTIOMETER
L. DTCT	: LIGHT DETECTING MODULE	VR. TRIM	: TRIMMER POTENTIOMETER

YST-MS30

Schm Ref	PART NO.	Description	Remarks
*	AAX09900	P.C.B.	AMP 057474
C1	AAX09500	C.CE	1000pF 50V 051720
C2	AAX09500	C.CE	1000pF 50V 051720
C3	VG287200	C.EL	10uF 50V 066833
C4	VG287200	C.EL	10uF 50V 066833
C7	VG287200	C.EL	10uF 50V 066833
C10	VG287200	C.EL	10uF 50V 066833
C11	FG644100	C.CE	0.01uF 50V 065452
C12	VG287200	C.EL	10uF 50V 066833
* C13	AAX09710	C.POL	0.047uF 50V 064959
* C14	AAX09710	C.POL	0.047uF 50V 064959
C15	UA655220	C.MYLAR	0.22uF 50V 065307
C16	VG287200	C.EL	10uF 50V 066833
C17	VG287200	C.EL	10uF 50V 066833
C20	UA655150	C.MYLAR	0.15uF 50V 065292
C21	UA655330	C.MYLAR	0.33uF 50V 044570
* C22	AAX09260	C.FILM	0.082uF 50V 065365
* C23	AAX09260	C.FILM	0.082uF 50V 065365
* C24	AAX09890	C.EL	470uF 25V 066444
C25	FG644100	C.CE	0.01uF 50V 065452
* C26	AAX09890	C.EL	470uF 25V 066444
* C27	AAX09890	C.EL	470uF 25V 066444
C28	VG287500	C.EL	47uF 50V 066963
C29	VG287200	C.EL	10uF 50V 066833
* C30	AAX09390	C.EL	0.47uF 50V 054182
C31	VG287200	C.EL	10uF 50V 066833
C32	UA655100	C.MYLAR	0.1uF 50V 065269
* C33	AAX09250	C.FILM	0.027uF 50V 054331
C34	VG287200	C.EL	10uF 50V 066833
C35	VG287500	C.EL	47uF 50V 066963
C36	VG287500	C.EL	47uF 50V 066963
C37	VG287200	C.EL	10uF 50V 066833
C38	VG289300	C.EL	1000uF 25V 066161
C39	VG287500	C.EL	47uF 50V 066963
C40	VG289300	C.EL	1000uF 25V 066161
C41	UA655100	C.MYLAR	0.1uF 50V 065269
C42	VG287200	C.EL	10uF 50V 066833
C43	VG287600	C.EL	100uF 25V 066840
C44	VG287200	C.EL	10uF 50V 066833
* C45	AAX09150	C.EL	4700uF 25V 066740
C46	VG287200	C.EL	10uF 50V 066833
* C47	AAX09530	C.CE	100pF 50V 065382
* C48	AAX09530	C.CE	100pF 50V 065382
C49	VG287500	C.EL	47uF 50V 066963
* C50	AAX09530	C.CE	100pF 50V 065382
* C51	AAX09530	C.CE	100pF 50V 065382
* C52	AAX09530	C.CE	100pF 50V 065382
C53	VG287200	C.EL	10uF 50V 066833
C54	FG644100	C.CE	0.01uF 50V 065452
C55	FG644100	C.CE	0.01uF 50V 065452
C56	FG644100	C.CE	0.01uF 50V 065452
CN1	XX707300	CN	B09B-PH-K-S 081731
CN3	LB932020	CN.BS.PIN	2P 081661

* New Parts

Schm Ref	PART NO.	Description	Remarks
CN4	XX707300	CN	B09B-PH-K-S 081731
* D1	AAX09220	LED(gr)	SLR-342MG 054160
D2	iF004600	DIODE	1SS133 069460
D3	iF004600	DIODE	1SS133 069460
D4	iF004600	DIODE	1SS133 069460
D5	iF004600	DIODE	1SS133 069460
D6	iF004600	DIODE	1SS133 069460
D7	iF004600	DIODE	1SS133 069460
IC1	XB247A00	IC	uPC4570HA 070111
IC2	XB247A00	IC	uPC4570HA 070111
IC3	XB247A00	IC	uPC4570HA 070111
* IC4	AAX09210	IC	TDA7370BV 054128
IC5	iG130400	IC	NJM78L06A 070429
IC6	XB247A00	IC	uPC4570HA 070111
IC7	XB247A00	IC	uPC4570HA 070111
IC8	XB247A00	IC	uPC4570HA 070111
* JK1	V4273000	JACK.MINI	MSJ-035-12D 053128
* JK2	V4273000	JACK.MINI	MSJ-035-12D 053128
* JK3	AAX09240	JACK.RCA	049691
* JK4	V5095000	JACK.DC	LGP7031-0300 054126
* JK5	AAX09170	SOCKET.DIN	CMS5008-0101 084753
Q1	VZ229400	TR	2SC3792 068859
Q2	VZ229400	TR	2SC3792 068859
Q3	XX707330	TR	2SA733 PQ 073507
Q4	XX707340	TR	2SC945A QP 073538
Q5	XX707330	TR	2SA733 PQ 073507
* Q6	AAX09180	FET	2SK304 E 051061
R43	HV754390	R.CAR.FP	39Ω 1/4W 067489
* R44	AAX09880	R.CAR.FP	22Ω 1/4W 054214
R54	Vi435900	R.MTL.OXD	0.1Ω 1W 068134
R55	HV754220	R.CAR.FP	22Ω 1/4W 067488
R56	HV754680	R.CAR.FP	68Ω 1/4W 067490
* R68	AAX09780	R.MTL.FLM	20KΩ 1/4W 068187
R69	VP441400	R.MTL.FLM	10KΩ 1/4W 068279
R70	VP441400	R.MTL.FLM	10KΩ 1/4W 068279
R71	VP441400	R.MTL.FLM	10KΩ 1/4W 068279
* ST1	AAX09540	TERM	M1698 084778
SW1	XX707260	SW.PUSH	SPPH13W 072687
* VR1	AAX09300	VR	15.5KA 048311
* VR2	AAX09310	VR	20KAx2 LM1-20 054314
* W7	AAX09400	CORD	9P MAIN 054159
	EP600250	SCR.BND.HD	3x8 ZMC2-Y 075636
	VT246400	HOLDER.LED	080338
*	AAX09650	HEAT.SINK	053466

* New Parts

YST-MS35D

Schm Ref	PART NO.	Description		Remarks
*	AAX09920	P.C.B.	AMP	057476
* C1	AAX09500	C.CE	1000pF 50V	051720
* C2	AAX09500	C.CE	1000pF 50V	051720
C3	VG287200	C.EL	10uF 50V	066833
C4	VG287200	C.EL	10uF 50V	066833
C7	VG287200	C.EL	10uF 50V	066833
C10	VG287200	C.EL	10uF 50V	066833
C11	FG644100	C.CE	0.01uF 50V	065452
C12	VG287200	C.EL	10uF 50V	066833
* C13	AAX09710	C.POL	0.047uF 50V	064959
* C14	AAX09710	C.POL	0.047uF 50V	064959
C15	UA655220	C.MYLAR	0.22uF 50V	065307
C16	VG287200	C.EL	10uF 50V	066833
C17	VG287200	C.EL	10uF 50V	066833
C20	UA655150	C.MYLAR	0.15uF 50V	065292
C21	UA655330	C.MYLAR	0.33uF 50V	044570
* C22	AAX09260	C.FILM	0.082uF 50V	065365
* C23	AAX09260	C.FILM	0.082uF 50V	065365
* C24	AAX09890	C.EL	470uF 25V	066444
C25	FG644100	C.CE	0.01uF 50V	065452
* C26	AAX09890	C.EL	470uF 25V	066444
* C27	AAX09890	C.EL	470uF 25V	066444
C28	VG287500	C.EL	47uF 50V	066963
C29	VG287200	C.EL	10uF 50V	066833
* C30	AAX09390	C.EL	0.47uF 50V	054182
C31	VG287200	C.EL	10uF 50V	066833
C32	UA655100	C.MYLAR	0.1uF 50V	065269
* C33	AAX09250	C.FILM	0.027uF 50V	054331
C34	VG287200	C.EL	10uF 50V	066833
C35	VG287500	C.EL	47uF 50V	066963
C36	VG287500	C.EL	47uF 50V	066963
C37	VG287200	C.EL	10uF 50V	066833
C38	VG289300	C.EL	1000uF 25V	066161
C39	VG287500	C.EL	47uF 50V	066963
C40	VG289300	C.EL	1000uF 25V	066161
C41	UA655100	C.MYLAR	0.1uF 50V	065269
C42	VG287200	C.EL	10uF 50V	066833
C43	VG287600	C.EL	100uF 25V	066840
C44	VG287200	C.EL	10uF 50V	066833
* C45	AAX09150	C.EL	4700uF 25V	066740
C46	VG287200	C.EL	10uF 50V	066833
* C47	AAX09530	C.CE	100pF 50V	065382
* C48	AAX09530	C.CE	100pF 50V	065382
C49	VG287500	C.EL	47uF 50V	066963
* C50	AAX09530	C.CE	100pF 50V	065382
* C51	AAX09530	C.CE	100pF 50V	065382
* C52	AAX09530	C.CE	100pF 50V	065382
C53	VG287200	C.EL	10uF 50V	066833
C54	FG644100	C.CE	0.01uF 50V	065452
C55	FG644100	C.CE	0.01uF 50V	065452
C56	FG644100	C.CE	0.01uF 50V	065452
C201	FG644100	C.CE	0.01uF 50V	065452
* C202	AAX09490	C.CE	22pF 50V	051094

* New Parts

Schm Ref	PART NO.	Description		Remarks
* C203	AAX09490	C.CE	22pF 50V	051094
C204	FG644100	C.CE	0.01uF 50V	065452
* C205	AAX09970	C.CE	0.01uF 50V	049191
* C206	AAX09970	C.CE	0.01uF 50V	049191
C207	FG644100	C.CE	0.01uF 50V	065452
* C208	AAX09510	C.CE	4.7pF 50V	055100
C209	FG644100	C.CE	0.01uF 50V	065452
C210	FG644100	C.CE	0.01uF 50V	065452
C211	FG644100	C.CE	0.01uF 50V	065452
C212	XX698870	C.POL	0.01uF 50V	065000
* C213	AAX09520	C.CE	12pF 50V	055101
C214	FG644100	C.CE	0.01uF 50V	065452
C215	VG287500	C.EL	47uF 50V	066963
C216	VG287500	C.EL	47uF 50V	066963
C217	VG290800	C.EL	4.7uF 63V	045313
C218	VG287600	C.EL	100uF 25V	066840
C219	VG287500	C.EL	47uF 50V	066963
C220	FG644100	C.CE	0.01uF 50V	065452
C221	FG644100	C.CE	0.01uF 50V	065452
C222	FG644100	C.CE	0.01uF 50V	065452
* C223	AAX09970	C.CE	0.01uF 50V	049191
CN1	XX707300	CN	B09B-PH-K-S	081731
* CN2	AAX09440	CN	B04B-PH-K-S	081698
CN3	LB932020	CN.BS.PIN	2P	081661
CN4	XX707300	CN	B09B-PH-K-S	081731
* CN5	AAX09430	CN	B02B-PH-K-S	081678
D1	AAX09220	LED(gr)	SLR-342MG	054160
D2	iF004600	DIODE	1SS133	069460
D3	iF004600	DIODE	1SS133	069460
D4	iF004600	DIODE	1SS133	069460
D5	iF004600	DIODE	1SS133	069460
D6	iF004600	DIODE	1SS133	069460
D7	iF004600	DIODE	1SS133	069460
* D201	AAX09550	DIODE.ZENR	MTZJ3.9A	050251
IC1	XB247A00	IC	uPC4570HA	070111
IC2	XB247A00	IC	uPC4570HA	070111
IC3	XB247A00	IC	uPC4570HA	070111
* IC4	AAX09210	IC	TDA7370BV	054128
IC5	iG130400	IC	NJM78L06A	070429
IC6	XB247A00	IC	uPC4570HA	070111
IC7	XB247A00	IC	uPC4570HA	070111
IC8	XB247A00	IC	uPC4570HA	070111
* IC201	XW001A00	IC	UDA1321PS/N101	050135
* IC202	AAX09190	IC	M24C02-W-BN6	050134
* JK1	V4273000	JACK.MINI	MSJ-035-12D	053128
* JK2	V4273000	JACK.MINI	MSJ-035-12D	053128
* JK3	AAX09240	JACK.RCA		049691
* JK4	V5095000	JACK.DC	LGP7031-0300	054126
* JK5	AAX09170	SOCKET.DIN	CMS5008-0101	084753
* JK202	V4510300	CN.USB	UBBR-2004W-30S-T	053589
* L201	AAX09410	COIL		051093
* L202	V3979700	COIL	ZJY51R5-M4PA	052153
* L203	V5117800	FER.CORE	B-10	056199

* New Parts

Schm Ref	PART NO.	Description	Remarks
Q1	VZ229400	TR	2SC3792 068859
Q2	VZ229400	TR	2SC3792 068859
Q3	XX707330	TR	2SA733 PQ 073507
Q4	XX707340	TR	2SC945A QP 073538
Q5	XX707330	TR	2SA733 PQ 073507
*Q6	AAX09180	FET	2SK304 E 051061
*Q201	AAX09580	TR	2SD1200F QR 068925
R43	HV754390	R.CAR.FP	39Ω 1/4W 067489
*R44	AAX09880	R.CAR.FP	22Ω 1/4W 054214
R54	Vi435900	R.MTL.OXD	0.1Ω 1W 068134
R55	HV754220	R.CAR.FP	22Ω 1/4W 067488
R56	HV754680	R.CAR.FP	68Ω 1/4W 067490
*R68	AAX09780	R.MTL.FLM	20KΩ 1/4W 068187
R69	VP441400	R.MTL.FLM	10KΩ 1/4W 068279
R70	VP441400	R.MTL.FLM	10KΩ 1/4W 068279
R71	VP441400	R.MTL.FLM	10KΩ 1/4W 068279
*R202	V5117800	FER.CORE	B-10 056199
*R203	V5117800	FER.CORE	B-10 056199
*R204	V5117800	FER.CORE	B-10 056199
*ST1	AAX09540	TERM	M1698 084778
*ST201	AAX09540	TERM	M1698 084778
*ST202	AAX09540	TERM	M1698 084778
SW1	XX707260	SW.PUSH	SPPH13W 072687
*VR1	AAX09300	VR	15.5KA 048311
*VR2	AAX09310	VR	20KAx2 LM1-20 054314
*W201	AAX09980	CORD.USB	2P 056205
*W202	AAX09270	CORD.USB	XB04B-PH-K-S 054157
*W7	AAX09400	CORD	9P MAIN 054159
*X201	V4539000	RSNR.CRYS	48MHz 053020
*	AAX09650	HEAT.SINK	053466
	EP600250	SCR.BND.HD	3x8 ZMC2-Y 075636
	VT246400	HOLDER.LED	080338

* New Parts

YST-MS30

YST-MS30

EXPLODED VIEW (YST-MS30)

MECHANICAL PARTS (YST-MS30)

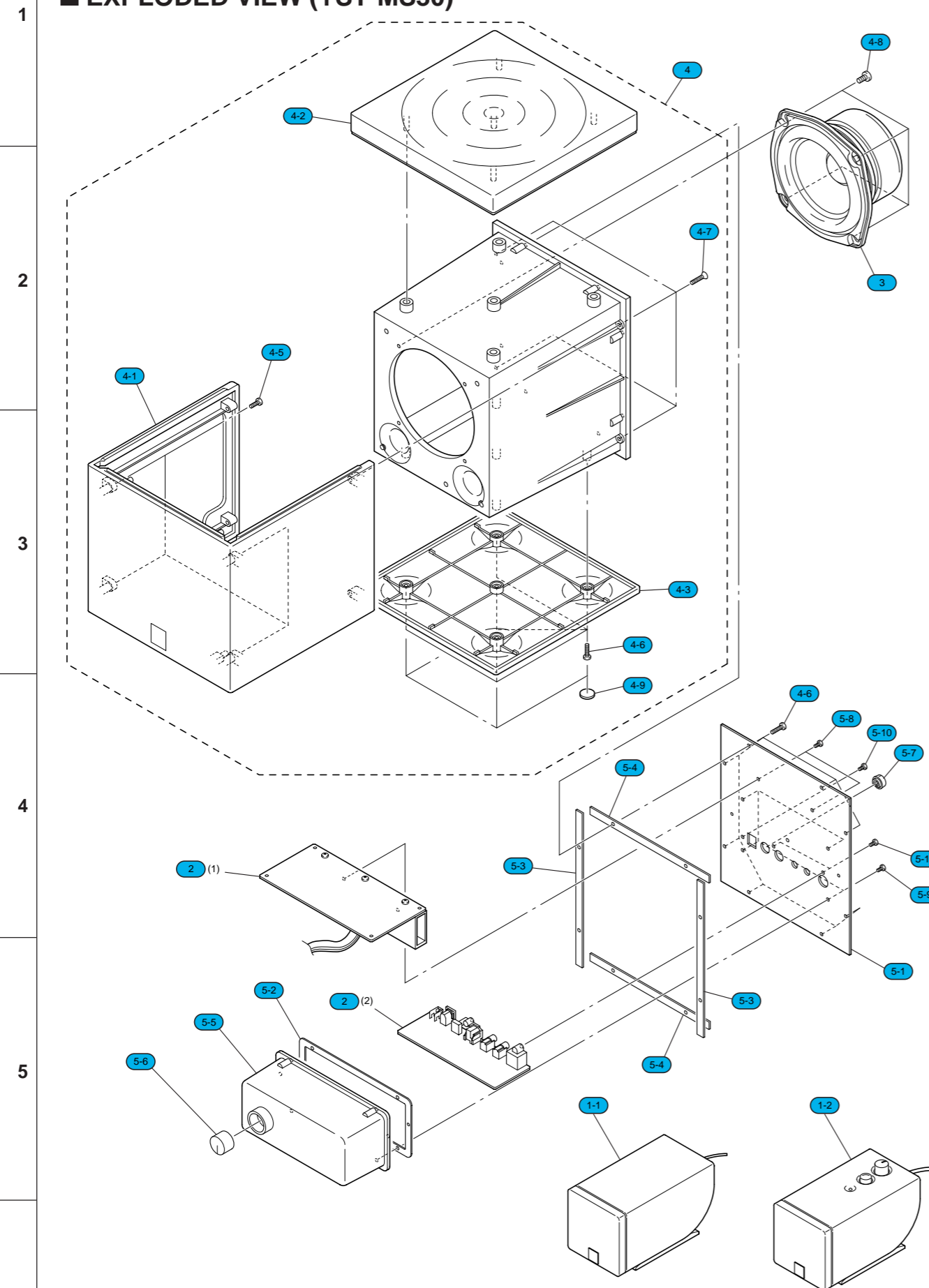

Ref. No.	PART NO.	Description	Remarks	Markets
* 1-1	AA12660	SATELLITE SPEAKER UNIT L	WH (L)	054025L
* 1-1	AA12680	SATELLITE SPEAKER UNIT L	BL (L)	054028L
* 1-2	AA12670	SATELLITE SPEAKER UNIT R	WH (R)	054025R
* 1-2	AA12690	SATELLITE SPEAKER UNIT R	BL (R)	054028R
* 2	AA09900	P.C.B ASS'Y	AMP	057474
3	XW801A00	SPEAKER UNIT	12cm JA1286	053939
* 4	AA09790	CABINET ASS'Y	WH	055286
* 4	AA09800	CABINET ASS'Y	BL	055293
* 4-1	AA09660	GRILLE ASS'Y	WH	054107
* 4-1	AA09670	GRILLE ASS'Y	BL	054108
* 4-2	AA09830	TOP PLATE	WH	053412
* 4-2	AA09840	TOP PLATE	BL	053413
* 4-3	AA09680	BOTTOM PLATE	WH	053414
* 4-3	AA09690	BOTTOM PLATE	BL	053415
* 4-5	AA09590	SCREW	3x10 Y P	018077
* 4-6	AA09620	SCREW	3x12 B P	054162
* 4-7	AA09610	SCREW	3x14 Y P	054053
* 4-8	AA09600	SCREW	4x10 B P	050315
* 4-9	AA09770	FOOT		055424
* 5-1	AA09850	REAR PANEL ASS'Y		053458
* 5-1	AA09860	REAR PANEL ASS'Y		054129
* 5-1	AA09870	REAR PANEL ASS'Y		054130
* 5-2	AA09340	CUSHION A		053455
* 5-3	AA09350	CUSHION B		054083
* 5-4	AA09360	CUSHION C		054084
* 5-5	AA09720	MOLD CASE		053456
* 5-6	AA09370	CUSHION BUSH		084849
* 5-7	AA09700	KNOB VOLUME SUB-W		053508
* 5-8	AA09630	BIND HEAD B-TITE SCREW	3x8 BL B	075243
* 5-9	AA09640	BIND HEAD P-TITE SCREW	3x10 BL	075321
5-10	ED330086	BIND HEAD SCREW	3x8 FCRM3-BL	075573
* *		ACCESSOIES		
* *	V4609500	AC ADAPTOR	1.2A, DC15V	054327
* *	V4609800	AC ADAPTOR	1.2A, DC15V	054329
* *	V4609900	AC ADAPTOR	1.2A, DC15V	054330
* *	V4609700	AC ADAPTOR	1.2A, DC15V	054328
	VS104300	NONSKID PADS	8pcs.	011716
	VS494400	CABLE, MINI PLUG	1.8m	040878

* New Parts

YST-MS35D

EXPLODED VIEW (YST-MS35D)

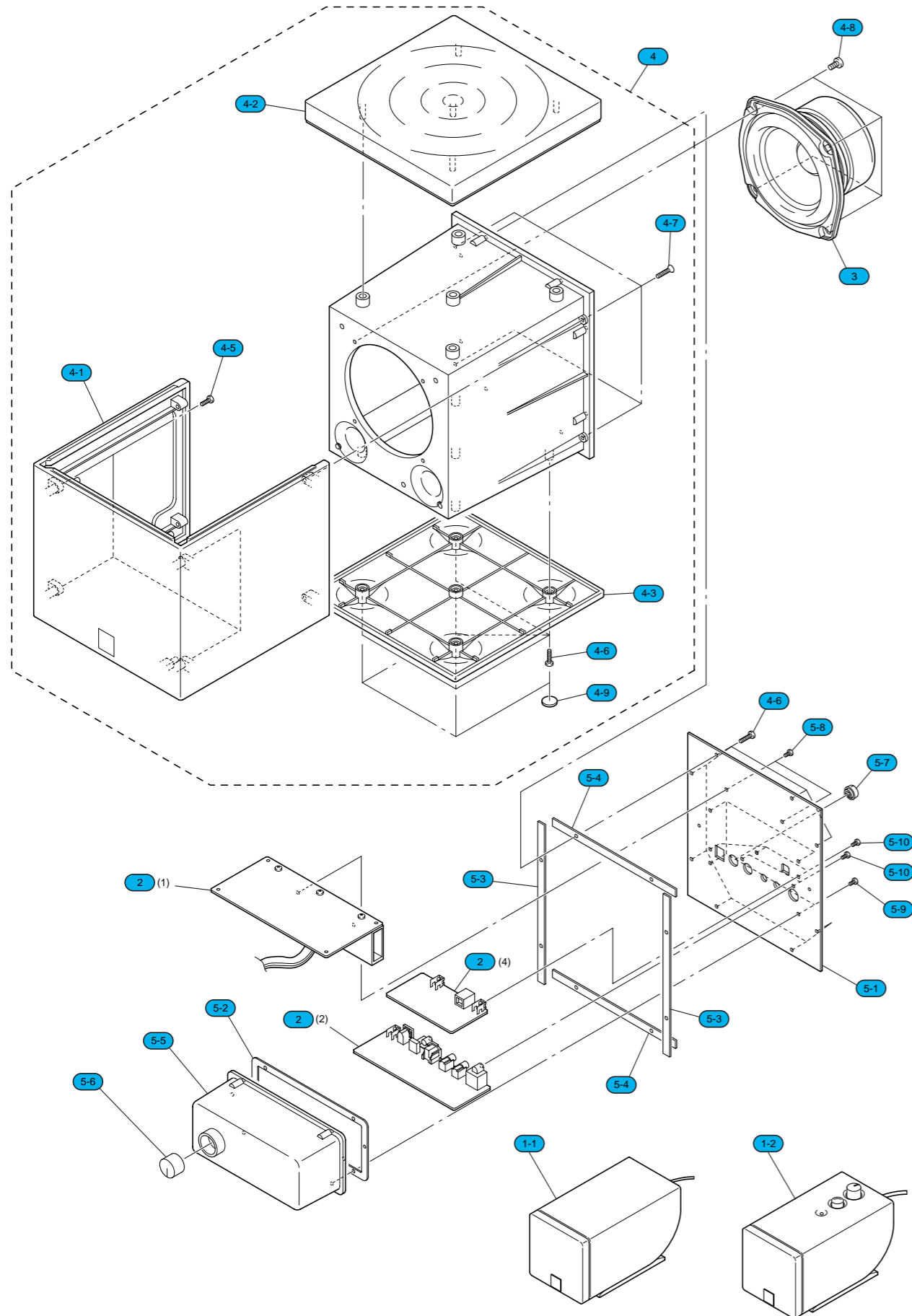

YST-MS35D

MECHANICAL PARTS (YST-MS35D)

Ref. No.	PART NO.	Description	Remarks	Markets
* 1-1	AAX12700	SATELLITE SPEAKER UNIT L	WH (L)	054031L
* 1-1	AAX12720	SATELLITE SPEAKER UNIT L	BL (L)	054035L
* 1-2	AAX12710	SATELLITE SPEAKER UNIT R	WH (R)	054031R
* 1-2	AAX12730	SATELLITE SPEAKER UNIT R	BL (R)	054035R
* 2	AAX09920	P.C.B. ASS'Y	AMP	057476
3	XW801A00	SPEAKER UNIT	12cm JA1286	053939
* 4	AAX09320	CABINET ASS'Y	WH	055294
* 4	AAX09330	CABINET ASS'Y	BL	055295
* 4-1	AAX09660	GRILLE ASS'Y	WH	054107
* 4-1	AAX09670	GRILLE ASS'Y	BL	054108
* 4-2	AAX09560	TOP PLATE	WH	054146
* 4-2	AAX09570	TOP PLATE	BL	054147
* 4-3	AAX09680	BOTTOM PLATE	WH	053414
* 4-3	AAX09690	BOTTOM PLATE	BL	053415
* 4-5	AAX09590	SCREW	3x10 Y P	018077
* 4-6	AAX09620	SCREW	3x12 B P	054162
* 4-7	AAX09610	SCREW	3x14 Y P	054053
* 4-8	AAX09600	SCREW	4x10 B P	050315
* 4-9	AAX09770	FOOT		055424
* 5-1	AAX09730	REAR PANEL ASS'Y		053460
* 5-1	AAX09750	REAR PANEL ASS'Y		054132
* 5-1	AAX09760	REAR PANEL ASS'Y		054133
* 5-2	AAX09340	CUSHION A		053455
* 5-3	AAX09350	CUSHION B		054083
* 5-4	AAX09360	CUSHION C		054084
* 5-5	AAX09720	MOLD CASE		053456
* 5-6	AAX09370	CUSHION BUSH		084849
* 5-7	AAX09700	KNOB VOLUME SUB-W		053508
* 5-8	AAX09630	BIND HEAD B-TITE SCREW	3x8 BL B	075243
* 5-9	AAX09640	BIND HEAD P-TITE SCREW	3x10 BL	075321
5-10	ED330086	BIND HEAD SCREW	3x8 FCRM3-BL	075573
* 5-11		ACCESSORIES		
* V4368200		USB CABLE	1P 2.0m	053019
* VS494400		CABLE, MINI PLUG	1.8m	040878
* V4609500		AC ADAPTOR	1.2A, DC15V	054327
* V4609800		AC ADAPTOR	1.2A, DC15V	054329
* V4609900		AC ADAPTOR	1.2A, DC15V	054330
* V4609700		AC ADAPTOR	1.2A, DC15V	054328
* VS104300		NONSKID PADS	8pcs.	011716
* V4612100		CD ROM		054325

* New Parts

Parts List for Carbon Resistors

Value	1/4W Type Part No.	1/6W Type Part No.	Value	1/4W Type Part No.	1/6W Type Part No.
1.0 Ω	HJ35 3100	HF85 3100	10 kΩ	HF45 7100	HF45 7100
1.8 Ω	HJ35 3180	*	11 kΩ	HF45 7110	HF45 7110
2.2 Ω	HJ35 3220	HF85 3220	12 kΩ	HJ35 7120	HF85 7120
3.3 Ω	HJ35 3330	HF85 3330	13 kΩ	HF45 7130	HF45 7130
4.7 Ω	HJ35 3470	HF85 3470	15 kΩ	HF45 7150	HF45 7150
5.6 Ω	HJ35 3560	HF85 3560	18 kΩ	HF45 7180	HF45 7180
10 Ω	HF45 4100	HF45 4100	22 kΩ	HF45 7220	HF45 7220
15 Ω	HJ35 4150	HF85 4150	24 kΩ	HF45 7240	HF45 7240
22 Ω	HF45 4220	HF45 4220	27 kΩ	HJ35 7270	HF85 7270
27 Ω	HJ35 4270	HF85 4270	30 kΩ	HF45 7300	HF45 7300
33 Ω	HF45 4330	HF45 4330	33 kΩ	HF45 7330	HF45 7330
39 Ω	HJ35 4390	HF85 4390	36 kΩ	HF45 7360	HF45 7360
47 Ω	HF45 4470	HF45 4470	39 kΩ	HF45 7390	HF45 7390
56 Ω	HF45 4560	HF45 4560	47 kΩ	HF45 7470	HF45 7470
68 Ω	HF45 4680	HF45 4680	51 kΩ	HF45 7510	HF45 7510
75 Ω	HF45 4750	HF45 4750	56 kΩ	HF45 7560	HF45 7560
82 Ω	HF45 4820	HF45 4820	62 kΩ	HF45 7620	HF45 7620
91 Ω	HF45 4910	HF45 4910	68 kΩ	HF45 7680	HF45 7680
100 Ω	HF45 5100	HF45 5100	82 kΩ	HF45 7820	HF45 7820
110 Ω	HJ35 5110	HF85 5110	91 kΩ	HF45 7910	HF45 7910
120 Ω	HF45 5120	HF45 5120	100 kΩ	HF45 8100	HF45 8100
150 Ω	HF45 5150	HF45 5150	110 kΩ	HF45 8110	HF45 8110
160 Ω	HJ35 5160	*	120 kΩ	HF45 8120	HF45 8120
180 Ω	HF45 5180	HF45 5180	150 kΩ	HF45 8150	HF45 8150
200 Ω	HF45 5200	HF45 5200	180 kΩ	HF45 8180	HF45 8180
220 Ω	HF45 5220	HF45 5220	220 kΩ	HJ35 8220	HF85 8220
270 Ω	HF45 5270	HF45 5270	270 kΩ	HF45 8270	HF45 8270
330 Ω	HF45 5330	HF45 5330	300 kΩ	HF45 8300	HF45 8300
390 Ω	HF45 5390	HF45 5390	330 kΩ	HF45 8330	HF45 8330
430 Ω	HF45 5430	HF45 5430	390 kΩ	HJ35 8390	HF85 8390
470 Ω	HF45 5470	HF45 5470	470 kΩ	HF45 8470	HF45 8470
510 Ω	HF45 5510	HF45 5510	560 kΩ	HJ35 8560	HF85 8560
560 Ω	HF45 5560	HF45 5560	680 kΩ	HJ35 8680	HF85 8680
680 Ω	HF45 5680	HF45 5680	820 kΩ	HJ35 8820	HF85 8820
820 Ω	HF45 5820	HF45 5820	1.0 MΩ	HF45 9100	HF45 9100
910 Ω	HF45 5910	HF45 5910	1.2 MΩ	HJ35 9120	*
1.0 kΩ	HF45 6100	HF45 6100	1.5 MΩ	HJ35 9150	HF85 9150
1.2 kΩ	HF45 6120	HF45 6120	1.8 MΩ	HJ35 9180	HF85 9180
1.5 kΩ	HF45 6150	HF45 6150	2.2 MΩ	HJ35 9220	HF85 9220
1.8 kΩ	HF45 6180	HF45 6180	3.3 MΩ	HJ35 9330	HF85 9330
2.0 kΩ	HJ35 6200	HF85 6200	3.9 MΩ	HJ35 9390	*
2.2 kΩ	HF45 6220	HF45 6220	4.7 MΩ	HJ35 9470	HF85 9470
2.4 kΩ	HJ35 6240	HF85 6240			
2.7 kΩ	HF45 6270	HF45 6270			
3.0 kΩ	HF45 6300	HF45 6300			
3.3 kΩ	HF45 6330	HF45 6330			
3.6 kΩ	HJ35 6360	HF85 6360			
3.9 kΩ	HF45 6390	HF45 6390			
4.7 kΩ	HF45 6470	HF45 6470			
5.1 kΩ	HF45 6510	HF45 6510			
5.6 kΩ	HF45 6560	HF45 6560			
6.8 kΩ	HF45 6680	HF45 6680			
8.2 kΩ	HF45 6820	HF45 6820			
9.1 kΩ	HF45 6910	HF45 6910			

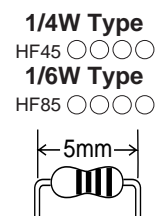
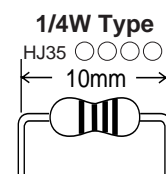

*: Not available

YST-MS30/MS35D

YAMAHA
