

THE B-2 POWER AMPLIFIER OWNER'S MANUAL

*Everything You Need to Know
for Operation of
this Technically Sophisticated
and Aurally
Satisfying Precision
Audio Component*

YAMAHA offers you thanks and congratulations on your choice of the B-2 power amplifier. Product of research directed at the ultimate in audio quality, based on a unique combination of sophisticated circuitry and advanced FET manufacturing know-how, the B-2 joins the famous B-1 in setting the standards by which the 'State-of-the-Art' is judged.

B-2

CONTENTS

SN# 2204

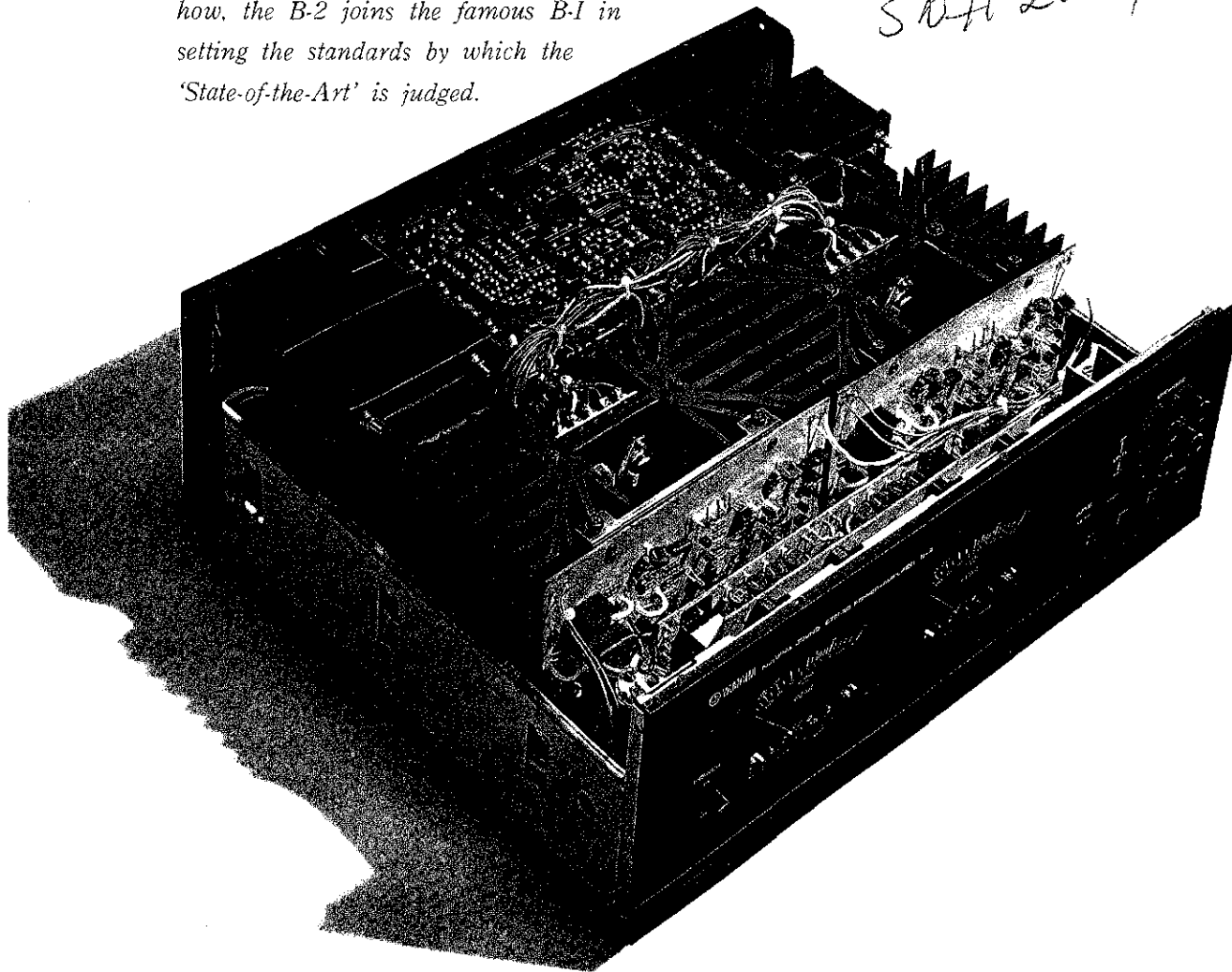

| | |
|--|----|
| C-1 or C-2? The Choice is Yours | 4 |
| Introducing Other Top-of-the-Line Yamaha Products | 5 |
| The Development of the B-2 Power Amplifier | 6 |
| Special Features of the B-2 Power Amplifier | 7 |
| Front Panel Controls | 8 |
| Rear Panel Connections and Controls | 9 |
| CAUTION — Read This Before Operating Your B-2 Power Amplifier | 10 |
| The Superb B-2 Power Amplifier | 11 |
| Connecting and Operating the B-2 with Other Components | 12 |
| The Accurate Peak Level Meters of The B-2 | 15 |
| For the Technically Minded | 16 |
| Block Diagram | 20 |
| Specifications | 21 |
| Trouble Shooting | 22 |

ABOUT THIS MANUAL

The B-2 is a high power amplifier. This owner's manual is required reading if you are to understand how to use it properly. Although fully protected by special trip devices against normal mishaps, it can still be seriously damaged by mis-use. By all means use this manual to speed your mastery of the B-2 power amplifier.

BEFORE YOU SWITCH ON

You are probably anxious to connect up the B-2. Skip straight to pages 8 and 9 for the names of the control functions and the location of connections. Full details for connecting and operating the B-2 power amplifier are on pages 10 to 14.

After you have heard for yourself the superb quality of which it is capable, browse through these next few pages to learn the how and why of the top performance, and meet the other members of the YAMAHA top quality line. For the more technically minded, performance graphs and full circuit details are given in pages 16 to 21.

Read this manual carefully and thoroughly to ensure that you get the fullest possible enjoyment from your B-2 power amplifier. Be sure to keep it in a safe place for future reference.

NOW A WORD OF WARNING

The following simple precautions will help to ensure that your B-2 power amplifier gives you the long years of trouble-free service of which it is capable.

1. The B-2 is extremely heavy for its size. Handle it with care, as befits a precision instrument, and ensure that the shelf or support on which it is placed is fully capable of bearing the entire weight.
2. The B-2 generates considerable heat when operated at high output powers. Mount it where air can circulate freely, and do not mount other electrical equipment (the C-1, C-2, or other preamplifier) on top of it.
3. Do not mount the B-2 where there is the least danger of exposure to rain or moisture: this is to eliminate fire and electrical shock hazards.
4. Do not mount the B-2 where it will be exposed to direct sunlight, excessive heat, or dust.
5. Do not use chemical solvents (such as benzene or alcohol) to remove traces of dirt. Wipe only with a soft, slightly damp cloth.
6. Do not attempt to carry out internal adjustments or repairs. Leave this to your local service representative.
7. Do read the special CAUTIONS on page 10.

B-2

C-1 OR C-2? THE CHOICE IS YOURS

**THE ULTIMATE CHOICE . . .
COMPREHENSIVE CONTROL FACILITIES
OR SOPHISTICATED SIMPLICITY**

The quality of reproduction given by the B-2 is such an advance that it can reveal new delights in long-familiar, favorite sources with your other existing audio components. But if preamplifier performance is the limiting factor in your equipment, YAMAHA offers two superb preamplifiers, either of which will combine with the B-2 power amplifier to give audio quality literally a whole order of magnitude better than most competitive equipment.

With every stage of the signal path handled by field-effect transistors (FETs) specially developed by YAMAHA's Semiconductor Division, the C-1 offers not only superb performance specifications, but an unparalleled flexibility of control features. It even includes a built-in signal generator/test oscillator for a host of sophisticated techniques. Special control functions include unusually precise bass and treble tone controls, with ± 0.5 dB steps and twin turnover frequencies, and unique 'presence' and 'acoustic' tone equalization controls.

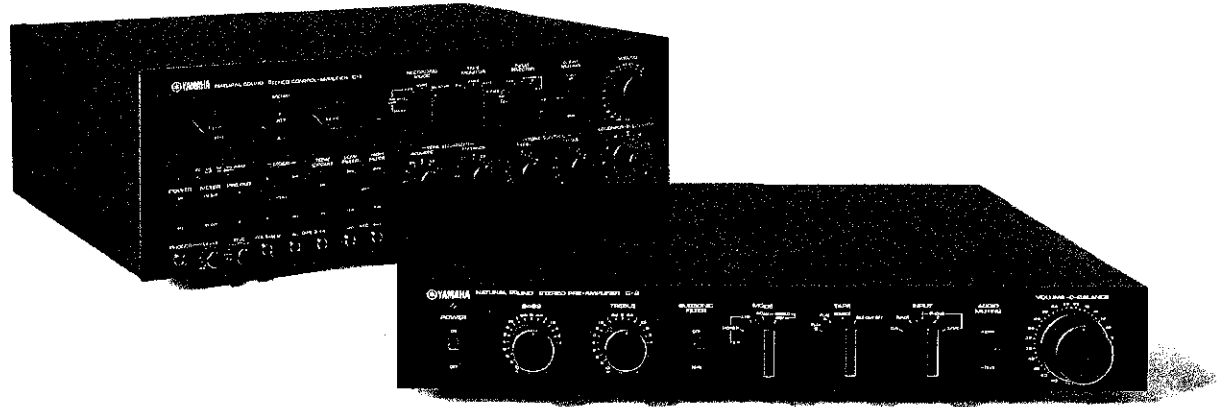

The latter offer delicate control of the nuances of musical balance, and flexible compensation for speaker and room resonances.

Mode, function, and selector switching is particularly comprehensive, handling up to three tape decks, three phono, one tuner, and two auxiliary inputs.

The same accurate peak level meters, reading from -50 dB to $+5$ dB (to $+35$ dB with -30 dB attenuation), are provided as on the B-2, so that both input and output levels can be monitored continuously with the C-1/B-2 combination.

Forming a dramatic contrast with the C-1, the C-2 represents a preamplifier which has been honed down to the ultimate in simplicity, with the technical sophistication to set new standards in audio reproduction.

Specially matched YAMAHA vertical FET pairs and advanced, fully complementary circuitry give

the C-2 its inherently low distortion (0.003%) and almost incredible signal-to-noise ratio (85dB for 2mV rated input).

Like the C-1, the C-2 features unusually precise bass and treble tone controls, with ± 0.5 dB steps, and four-gang volume control for better S/N at normal listening levels.

As well as tape recording and monitoring, subsonic filter, and audio muting, the C-2 offers one outstanding extra: a head amplifier for moving coil cartridges which gives an amazing 70dB S/N for 50μ V rated input, as good as many amplifiers offer for standard moving magnet phono cartridges! Free from the drooping frequency response and non-linear distortion of step-up transformers, the YAMAHA IC head amp. gives extremely low distortion and crisp, accurate transients.

C-1 . . . ? C-2 . . . ? The choice — and the pleasure — is yours.

B-2

INTRODUCING OTHER TOP-OF-THE-LINE YAMAHA PRODUCTS



Ideal for the B-2 plus C-1 or C-2 are the three-way NS-1000 and NS-1000M (for monitor) speaker systems. Both de luxe ebony and professional all-black monitor cabinets form matched symmetrical stereo pairs.

Mid-range and high frequency drivers feature beryllium domes only 30 microns thick, produced by YAMAHA-developed vapor-deposition technology. Mastery of beryllium, previously dismissed as virtually unworkable, has made this exceptionally light and strong metal available for a new generation of YAMAHA speakers.

The result has been to give these speakers outstandingly even diffusion of sound and an excellent transient response that comes from ultra-light dome structures. With massive power-handling capacity and correspondingly rapid heat dispersion, and a wide, flat response, the open and unforced clarity of reproduction is perfectly balanced by dynamic transients and an impressive sense of scale.

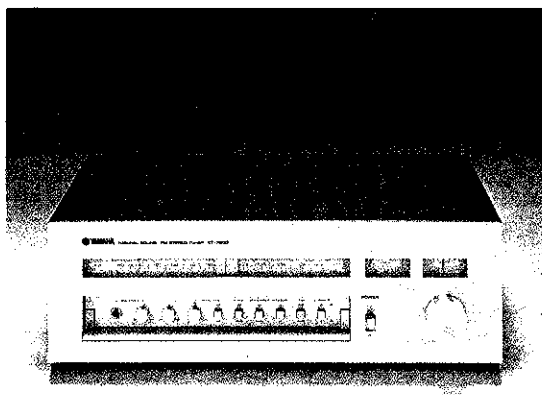

The smooth uncluttered lines of the CT-7000 tuner give little hint of the technical sophistication hidden within it. Designed to combine the ultimate in radio reception performance with strictly comparable audio quality, it shares with the B-1, B-2, C-1 and C-2 the honor of setting the standards by which the state-of-the-art is judged.

Low distortion is one important theme: the choice of wide or narrow selectivity enables local stations (on 'wide') to be received with only 0.04% harmonic distortion.

Phase-locked loop plus negative feedback, direct metering of multipath signal levels, adjustable muting levels, Auto Blend function for optimum S/N ratios with all signal strengths, and AFC which cuts out when you touch the tuning knob, are some of the unusual features of this highly sensitive and stable tuner. Most important of all is the superb audio quality.



This, the YAMAHA top performer in the reproduction of recorded discs, features direct drive by high precision DC servomotor. Motor rpm are low, and the small number of moving parts (no idler pulley or belt) means less to go wrong or wear out, so full performance specifications should be preserved throughout a long service life. A mere 10 watts drives the motor, so little energy is wasted in potentially harmful heat and vibration.

Discreet stroboscopic indication of speeds (each individually adjustable) with wow and flutter levels more like a professional disc-cutter than a turntable unit make the YP-800 a pleasure to use.

The sensitivity of the S-type static-balance arm is so high that perfect tracking is possible with the latest of high compliance cartridges. Full anti-skating inside force cancellation is provided, and both headshell cartridge contacts and pin plugs are gold plated to give low contact resistance. A superb unit. The YP-800.

B-2

THE DEVELOPMENT OF THE B-2 POWER AMPLIFIER

A MAJOR STEP NEARER THE IDEAL POWER AMPLIFIER

YAMAHA's aim for the B-2 was a major advance in power amplifier performance, with higher signal-to-noise ratio, lower distortion, and better waveform fidelity than anything currently available, reflecting superior performance characteristics in equally outstanding tonal quality.

That obviously meant building a DC amplifier (i.e. one with a response flat to 0Hz or DC). Only a DC amplifier can retain full waveform fidelity, and keep the full 'punch' of the original down to sub-sonic frequencies. But conventional circuitry and bi-polar transistors alone were totally inadequate. Once again YAMAHA was faced with the challenge of developing new circuits and new circuit elements to make another leap forward like that which gave the C-I and B-I all-FET amplifiers. The success achieved is now yours to enjoy in the B-2.

VERTICAL FET SUPER-PAIRS

YAMAHA's ability to control precisely the purity of the silicon used in FETs, and the inherent superiority of the vertical FET as an audio amplifier device, enabled development of FETs with excellent linearity, and in perfectly matched N- and P-channel pairs.

High linearity means faithful amplifier response from the lowest to extremely high levels, with low distortion.

Super-accurate matching of FET pairs, which are virtually perfect mirror images of each other, is essential if the full advantages are to be gained from complementary circuits (where the signal is split into positive and negative elements which are amplified separately). The YAMAHA super pairs greatly improve circuit symmetry, for reduced crossover and harmonic distortion. The improvement is particularly evident at low listening levels: reproduction remains sweet and true down to a whisper.

The new FETs are used in the first stage and power output circuits, where they make the critical contribution to improved performance.

NEW SUPER CIRCUITS

YAMAHA's experience in developing the circuits to exploit the special advantages of the FETs used in the C-I and B-I amplifiers is one secret of the unique B-2 circuit design. The B-2 design is, however, circuit-centered: the best components were chosen for each place in the circuit, and were specially developed when nothing suitable existed.

The first stage uses a specially selected pair of FETs with matched characteristics in a differential amplifier which employs a cascode-bootstrap configuration to eliminate the distortion which can arise from changes in input impedance.

A fully complementary push-pull configuration is used not only for the output power stage (where this is normal practice) but also for driver and pre-driver stages too. The fully complementary symmetrical push-pull circuit used for the driver stage enables all the advantages of the super matched-pair FETs in the fully complementary output-capacitorless single-ended push-pull (OCL-SEPP) output stage to be fully exploited.

B-2

SPECIAL FEATURES OF THE B-2 POWER AMPLIFIER

A TRUE DC AMPLIFIER

The whole NFB loop contains not one capacitor. There are no coupling, output, input, nor any other capacitors. The B-2 can amplify all frequencies right down to 0Hz or direct current. It is therefore a DC amplifier in two important senses: Direct Coupled and Direct Current.

ACCURATE TRANSIENT AND WAVEFORM TRANSMISSION

Every factor necessary to ensure precise duplication of the input waveform, however complex or full of sudden loud transients, is present in the B-2, from ultra-linear FETs, through symmetrical circuit configurations and minimal NFB levels, to DC amplification. Phase response is flat within $+0^\circ$ and -30° from DC to 100kHz.

NOISE TOO QUIET TO HEAR

The full 115dB S/N ratio of the B-2 (IHF-A) sets a new standard for power amplifier performance. It means that even with preamplifier gain turned right up, you should never hear any hiss noise from the B-2. Your favorite music will be heard against a silent back-drop.

DISTORTION YOU CAN FORGET ABOUT

Rated total harmonic distortion is below 0.08% from 20Hz to 20kHz with both channels

driven at 100 Watts into 8 ohms. At 70 Watts it drops still further, to 0.015%, and at 10 Watts (a typical domestic listening level) it is an almost incredible 0.005%. These figures put the B-2 in the very top rank of power amplifiers, and effectively mean that distortion should never bother you. Forget about it.

SUPERB OPEN-LOOP RESPONSE — REDUCED NFB —

The extremely high linearity of the FETs developed for the B-2, and the low power required to operate them, enable very simple (though sophisticated) circuits to be used. The semiconductors are used only over the most linear portions of their characteristics. The combined distortion of devices and circuits is only 0.16% before NFB is applied, cutting NFB requirements. This gives a dramatic improvement to the dynamic performance characteristics. Slew rate is 60 Volts per microsecond!

ACCURATE PEAK LEVEL METERS

The meters used are essentially those developed for the B-I/UC-I and C-I amplifiers, giving an accurate reading of the level of a single sine-wave cycle at 10kHz. They can be used not only to display the B-2 output in Watts (for 8-ohm speakers), but also independently to measure levels in external components. In addition to the Watts

scale, there is also a dB scale reading from -50 to $+5$ dB.

HIGHLY STABLE OPERATION

Drift of the center (operating) potential could be most dangerous in a DC amplifier: DC might appear at the speaker terminals. This danger has been overcome with the B-2, because drift from switch-on to the steady state is within ± 10 mV, and temperature-dependent drift from 0° to 50° C is similarly negligible.

FULL PROTECTION AND RELIABILITY

A diode-matrix circuit protects FETs from rush currents, and a potential-limiter guards them against output overloads. Speakers are isolated from the amplifier output if ever a DC component appears across them. This circuit doubles as the muting to cut out any initial clicks or thumps after switching on. The transformers are protected by thermal trips from overheating. An LED indicates when protective circuits are in operation.

INDEPENDENT L/R POWER SUPPLIES

The B-2, like the B-I, features completely independent power supplies for the left- and right-hand channels, with separate transformers and huge electrolytic smoothing capacitors (63V, 18,000 μ F \times 4). Inter-channel separation and dynamic response are improved by this highly effective voltage regulation.

B-2

FRONT PANEL CONTROLS

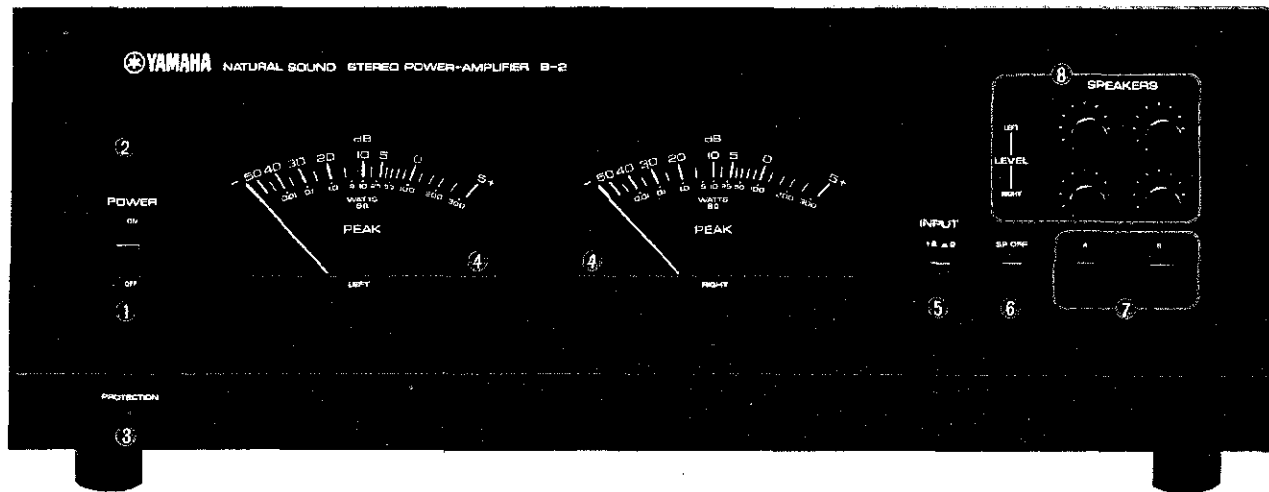

1 POWER Switch

With this switch ON, the main electrical supply will be connected. Note that the B-2 will remain silent for some seconds while a muting relay cuts out the pops and clicks that can occur immediately after switching ON.

2 POWER LED Indicator

With the POWER switch in the ON position, this light-emitting diode will illuminate, indicating that the main electrical supply has been connected.

3 PROTECTION LED

When this light-emitting diode illuminates, it indicates that one of the protective circuits of the B-2

is operating. It can also illuminate briefly after first switching ON. This is normal, and only indicates that the muting relay is operating.

4 PEAK Level Meters

These indicate B-2 output power levels from 0.01W to 300W on a logarithmic scale. They are also calibrated in dB for measuring external equipment output levels.

5 INPUT 1/2 Selector

This selects either of the two sets of input terminals on the rear panel.

6 SP OFF Switch

This mutes all speakers, leaving the B-2 itself and its meters still functional.

7 A/B Speaker Selector Switches

These push buttons select whether A or B speaker systems (not both) shall be heard.

8 SPEAKERS LEFT/RIGHT LEVEL Controls

These knobs attenuate the B-2 output level for each speaker, enabling switching between speakers with different efficiencies without changes in level, etc.

B-2

REAR PANEL CONNECTIONS AND CONTROLS

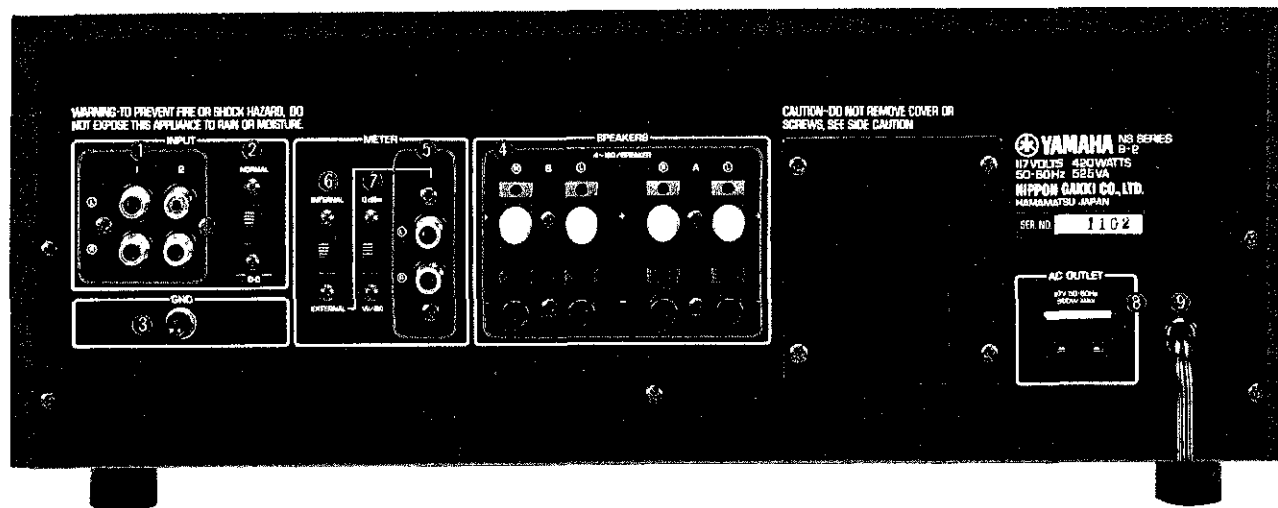

① INPUT 1/2 Terminals

Two sets of INPUT terminals are provided for a comparison of preamplifiers, or one pair may be shorted to form an INPUT OFF option.

② NORMAL/DC Mode Selector

In the NORMAL position, an input capacitor is connected; in the DC position this is short-circuited for flat response to 0Hz.

③ GND (Ground) Terminal

This should be connected to a good electrical ground (consult your electrical dealer if you need advice). Do NOT connect this terminal to the ground, or common terminal on the speaker (output) stage.

④ SPEAKER Terminals

Two sets of terminals are provided, for a choice of A or B speaker systems. Simple insertion of the connecting wire and firm clamping by rotary knobs are features of these terminals.

⑤ METER EXTERNAL

Input Terminals

Pre- or power amplifiers, etc, whose output levels are to be measured by the B-2 meters are connected to these terminals.

⑥ INTERNAL/EXTERNAL METER

Switch

In the NORMAL position, the B-2 meters will indicate the B-2 power output. When this switch is in the EXTERNAL position, the meters will indicate the output levels of the external equipment attached to the EXTERNAL input terminals.

⑦ 0 dBm and W/8Ω Selector Switch

In the 0 dBm position, the B-2 meters will indicate 0dB for an external input of 775mV into 43kΩ. In the W/8Ω position, they indicate 0dB for 100 Watts into 8Ω (with 100kΩ internal impedance).

⑧ AC OUTLET

If a spare AC OUTLET is provided on the rear of your B-2, it can only deliver a maximum of 300 Watts.

⑨ AC Electrical Power Line

The electrical power line should be plugged into a normal domestic AC supply outlet capable of delivering approximately one kilowatt, NEVER a spare AC outlet on other audio equipment.

B-2

CAUTION — READ THIS BEFORE OPERATING YOUR B-2 POWER AMPLIFIER

- 1 ALWAYS connect your B-2 directly to its own AC supply socket. Ensure that the socket is rated to deliver one kilowatt of power.

NEVER connect the B-2 to spare AC outlets on other audio equipment (preamplifiers, etc.).
- 2 ALWAYS ensure that a good GROUND connection is made

NEVER connect this to the GROUND or common terminal of the speaker (output) stage.
- 3 ALWAYS switch the POWER switch OFF when making or breaking connections to the B-2.

NEVER make or break connections with the POWER switch ON. The 100 Watts per channel output of the B-2 is more than enough to destroy most speakers if carelessly handled. The B-2 may also be damaged.
- 4 ALWAYS turn the speaker muting switch (SP OFF on the front panel) OFF and check the power output level when switching between different program sources or preamplifiers, etc. The meters will indicate output levels even with the speakers muted.
- 5 ALWAYS turn the output level attenuators (LEVEL controls on the front panel) down to minimum before operating new speakers, and then raise them gradually to maximum (reducing input levels as necessary).

NEVER use the full, unattenuated output initially: if levels are too high, you may not have time to reduce them before damage is done.
- 6 ALWAYS commence external equipment output level measurements with the meter selector on the rear panel in the $W/8\Omega$ position, i.e. the least sensitive position, even when measuring preamplifier outputs.

NEVER switch over to the 0dBm position when power amplifier outputs are connected. Even with lower level preamplifier outputs, do not switch over without reducing the level to about $0.1W/8\Omega$, or the meters may be damaged by overloading.
- 7 ALWAYS use speakers between 4 and 16 ohms impedance.

NEVER use speakers which have impedances below 4 ohms, nor connect two or more speakers in parallel without checking that the effective impedance will not drop below 4 ohms.
- 8 ALWAYS use speakers which have been rated to handle the power the B-2 can deliver, or ensure that the attenuators are used to protect them against overload.
- 9 WAIT for a few seconds after switching ON for the PROTECTION LED to wink OUT. This indicates that the muting circuit which protects your speakers from any initial clicks and pops has cut out.
- 10 NEVER mount other equipment on or immediately beside the B-2: allow plenty of space for ventilation. The B-2 generates a lot of heat at full power.
- 11 Observe the cautions on mounting location inside the front cover of this manual (nowhere hot, dirty, or wet: somewhere strong enough to support it). Remember that the B-2 weighs over 57 lbs !

B-2

CONNECTING AND OPERATING THE B-2 WITH OTHER COMPONENTS

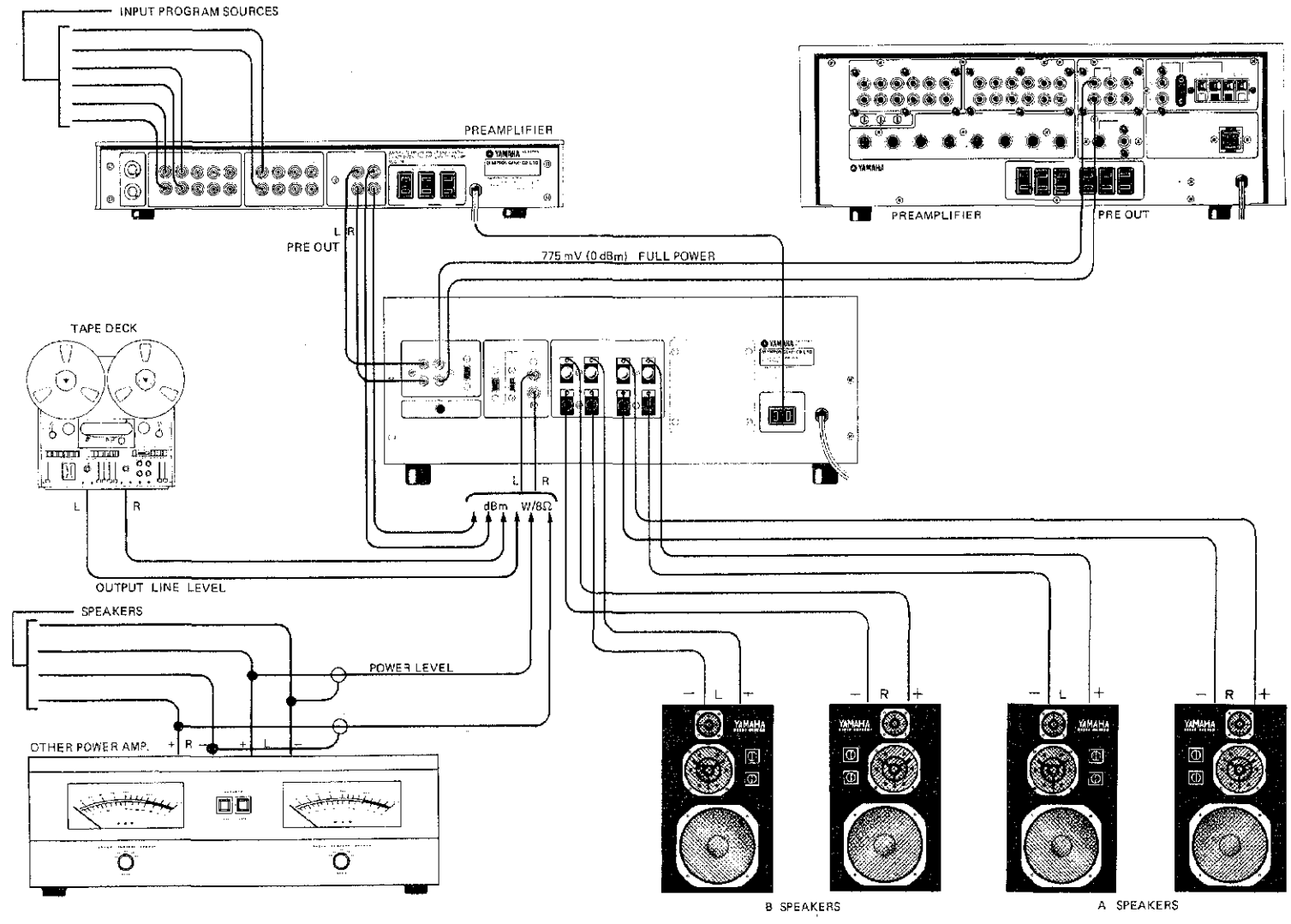

CONNECTING THE POWER SUPPLY

First ensure that the POWER switch is OFF. Then insert the power plug into an AC main supply wall socket. The B-2 draws approximately 300 Watts under no-signal conditions, and can draw as much as app. 1kW at peaks, so the capacity of the wall socket should be at least 1kW. If an extension cord must be used to link the B-2 and the nearest wall socket, use wire of the same gauge or thicker than that supplied with the B-2. The use of a thinner wire, even where not positively dangerous, may result in a resistive voltage drop which will degrade the B-2's response to sudden high level peaks. Under NO circumstances should a spare AC outlet on another item of audio equipment be used to supply the B-2: you would only succeed in blowing protective fuses, or in causing severe overloading.

The spare AC outlet socket provided on the rear panel of the B-2 (not available in certain areas) is of the unswitched type: any item of audio equipment attached to it must be switched OFF and ON by its own switch; it will not be controlled by the B-2 POWER switch. Limitations imposed by the capacity of the B-2 main AC power cord, etc., mean that only 300 Watts can be drawn from this socket. This should be adequate for a turntable, preamplifier, tuner, or other relatively low-power equipment, but the power demand should be checked carefully to ensure that the 300 Watt limit is not exceeded.

INPUT CONNECTIONS

Before making (or breaking) any connections on the input side of the B-2, ensure that the POWER switch is OFF. The B-2 is provided with two sets of input terminals, and selection of either is by push-button selector on the front panel. This choice is valuable for making A/B comparisons between different preamplifiers or for direct connection of audio equipment, which may not need to pass through a preamplifier, in addition to the normal preamplifier connection. Alternatively, one of the two sets of terminals can be shorted, in which case the front panel selector will effectively act as an INPUT OFF switch.

Also, there is a selector switch on the rear panel which offers the choice of NORMAL or DC input modes. In the NORMAL mode, a conventional input capacitor is used to isolate the B-2 input from direct current (DC) signals. In the DC mode, all signals are applied directly to the first stage of the B-2, without the input capacitor, which is short-circuited.

Since the B-2 is a DC amplifier, any DC signal appearing at the input would be amplified and applied to the speakers. Speakers connected to the B-2 are fully protected against this eventuality by extremely rapid response circuitry which detects the DC and immediately operates a relay to isolate the speakers. This, however, will cause

addition to be interrupted until the DC signal is cleared. To eliminate this possibility, the selector switch should usually be set to NORMAL. When you wish to use the full low frequency response of the B-2 to DC (0Hz), switch over to the DC setting, remembering to mute the speakers before you do so.

The GROUND terminal should be connected to a good electrical ground, particularly if there is any trouble from 'hum.' Direct connection to the preamplifier GND terminal is also possible. However, UNDER NO CIRCUMSTANCES should this terminal be connected to the speaker output stage (common) ground terminals.

NORMAL/DC INPUT SELECTOR

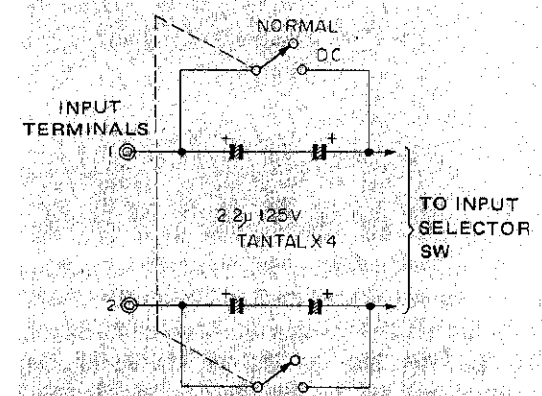

SPEAKER CONNECTIONS

The B-2 makes provision for connection of two sets of two stereo speakers (A and B), with selection of either pair (not both) by push-button switch on the front panel.

The terminals used are specially designed for easy connection (just insert the appropriately stripped speaker wire into the terminal hole, and screw down the retaining knob) and a firm and positive grip.

Simple and Effective Connectors

Speakers of any impedance between 4 and 16 ohms may be used, but the lower the impedance, the heavier the gauge of connecting wire that should be used: a cable rated to carry at least 5A should be adequate even with 4-ohm speakers, preventing overheating of the cable or deterioration of the response due to resistive losses.

Do NOT use speakers which have impedances of less than 4 ohms, OR connect speakers in parallel so that the effective impedance would drop below 4 ohms: in this case the overload protective circuit would operate continually, and prevent audition. Should it fail to operate in time, serious damage would be caused to the B-2.

SPEAKER MUTING AND LEVEL CONTROLS

The level controls for each speaker of the two stereo pairs provided for in the B-2, enable switching between pairs with quite different efficiencies to be achieved at the same listening volume.

The muting (SP OFF) switch enables level to be checked and set, and switching from source to source, etc., to be performed, while the speakers are effectively disconnected, because the meters remain operative.

First mute the speakers, and set the B-2 output level at about 1 Watt with some convenient program source. Switch between the two pairs of speakers with different efficiencies, and determine, if you do not already know, which are the less efficient, and turn the speaker levels up to maximum for them. Readjust the source input level to a convenient listening volume (if necessary), and switch to the more efficient pair. Reduce the speaker level settings for these until switching between the two pairs of speakers produces no noticeable change in level.

Note that with these level controls zero output can be achieved by turning the speaker level controls fully anti-clockwise. Better use is made of the B-2's inherent performance if these controls are turned fully up, and reductions in level are made with the preamplifier, at the input side.

EXTERNAL METERING

The B-2 meters give an accurate indication of peak power levels for 8-ohm speakers. For 4-ohm speakers the meter readings should be doubled to give the true power output, and with 16-ohm speakers, the readings should be halved.

The outputs of other power amplifiers can be measured by connecting the METER INPUT terminals on the rear panel of the B-2 in parallel with the speakers of the other amplifiers (or across dummy resistors of the same nominal impedance and power rating as the speakers). Ensure that the meter-scale selection switch on the rear panel of the B-2 is set to $W/8\Omega$: power outputs for the external amplifier can be read as soon as the meter is switched to EXTERNAL. This feature is extremely useful in ensuring that the outputs from several amplifiers in a multi-amplifier configuration are precisely aligned.

The output of the preamplifier feeding the B-2 can also be measured just as easily. If it has two outputs, one can be permanently connected to the B-2 meter input and the other to the amplifier input itself. If it only has one, the POWER switch must be turned OFF and the connections made. The meter-scale selection switch is set to dBm on the rear panel: in this case it is best to start in the $W/8\Omega$ position (which is less sensitive), or to turn the preamplifier output well down, so as to prevent overloading, which might damage the meters.

B-2

THE ACCURATE PEAK LEVEL METERS OF THE B-2

The meters in the B-2 are essentially those developed for the UC-I control unit used with the famous B-I all FET basic power amplifier, and also incorporated in the C-I control amplifier. They differ from conventional VU units, which are designed primarily to give an indication of how loud the sound will seem. The B-2 meters are peak-reading meters, which follow rapidly and accurately the instantaneous variations in signal.

The range of measurement is extremely wide: from 1 mW to 300 W with 8-ohm speakers, or from -50 to +5dB, on a single scale, without any range-extending attenuation. The meters are extremely accurate throughout their very wide range, within ± 1 dB from +5 to -20dB, ± 2 dB from -20 to -40dB, and only ± 3 dB from -40 to -50dB. The frequency response is also flat within ± 1 dB from 20Hz to 20kHz.

Peak Level Meter Response

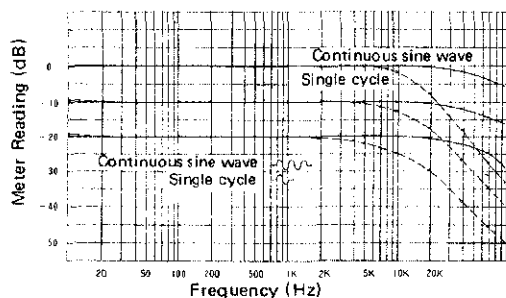

The special combination of ultra-fast rise time, 100 microseconds, with comparatively slow decay time, 1 sec., means that peaks of audio power far too brief for most meters to register are held long enough to register clearly. Accuracy of indication is within 2dB even for a single sine-wave cycle at 10kHz.

In the EXTERNAL mode, switched to the 0dBm setting, an input of 775 mV registers 0dBm on the B-2 meters, which have an internal impedance of 43k Ω . This is useful not only in measuring the input levels of preamplifiers not provided with meters, but also for the measurement of the output levels from the various program sources (tuners, tape-decks, etc.) attached to the pre-amplifier input.

Meter Circuit Block Diagram

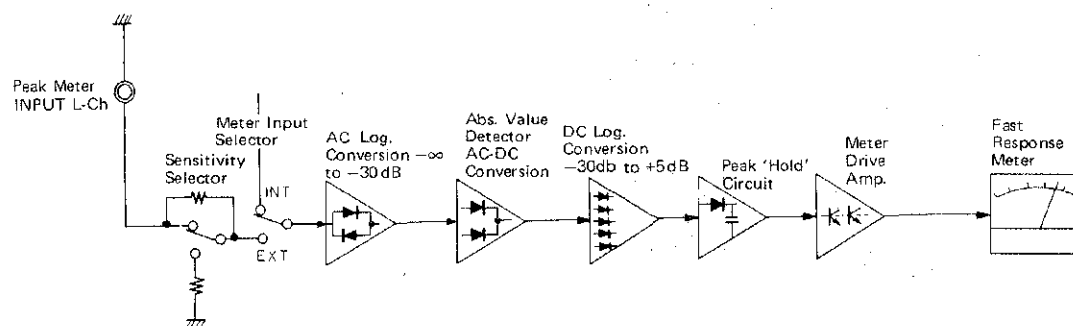

METER READINGS (dBm, Volts)

| VOLTAGE | METER SCALE (dB) | VOLTAGE | METER SCALE (dB) |
|---------|------------------|---------|------------------|
| 2.45 mV | -50 | 549 mV | -3 |
| 4.36 mV | -45 | 615 mV | -2 |
| 7.75 mV | -40 | 691 mV | -1 |
| 13.8 mV | -35 | 729 mV | -0.5 |
| 24.5 mV | -30 | 775 mV | 0 |
| 43.6 mV | -25 | 822 mV | +0.5 |
| 77.5 mV | -20 | 868 mV | +1 |
| 138 mV | -15 | 977 mV | +2 |
| 245 mV | -10 | 1.09 V | +3 |
| 436 mV | -5 | 1.23 V | +4 |
| 489 mV | -4 | 1.38 V | +5 |

B-2

FOR THE TECHNICALLY MINDED ...

THE NEW B-2 POWER FETS

The power FETs developed for the B-2 are the 2SK-76 (N-channel) and the 2SJ-26 (P-channel). They have closely matched 'mirror-image' characteristics, specially developed for fully complementary circuitry. YAMAHA investigated exhaustively the chip sizes, impurity levels, and gate mesh structure, and established rigorous production controls, to achieve a wide operational range over which paired characteristics could be obtained.

A final special stage of pair selection eventually yields the super-pair FETs shown in the photograph. It is clear that these YAMAHA FETs have the following special features:

- Good complementarity
- Good linearity over a wide operating range
- High voltage gain ($\mu \cong 7.5$)
- High operating voltage



CIRCUIT-CENTERED FET DEVELOPMENT

The development of the B-2 commenced with the identification of the performance categories in which an audio amplifier must excel, went on to design circuits which would be capable of the required performance in each category, and was completed by the development of semiconductor devices (FETs) which could satisfy the severe demands of such circuits. The technology required to develop and exploit FETs with these characteristics included the ability to design the devices, to translate them into practical terms, to manufacture them, and particularly to grow high purity epitaxial layers of adequate depth.

UNIQUE CIRCUIT CONFIGURATION

The circuit configuration consists of a first stage differential FET cascode-bootstrap circuit, a pre-drive stage with current-mirror differential push-pull amplification, a drive stage featuring fully complementary symmetrical push-pull, and an output stage using the super-pair FETs in a fully complementary configuration with parallel push-pull OCL circuitry: all stages are directly coupled, and form a true DC (0 Hz) amplifier.

PRE-DRIVE STAGE

The rigorously matched super low-noise FET pair in the first stage are coupled thermally and form a differential amplifier. In the B-2 there is no problem associated with long-term drift in

the center or 'balance' potential which is connected to the speakers. This is assured by the use of high *gm* FETs operated close to the ideal IDSS, with temperature-compensated constant current source bias, giving a common mode rejection ratio (CMRR) which is so high that center point potential drift is within 10mV. Traces of electrical supply ripple are also cancelled, so that in combination with the super low-noise FETs, the S/N ratio is better than 115dB (IHF-A, 4.6k Ω input short).

Voltage Amplification Stage

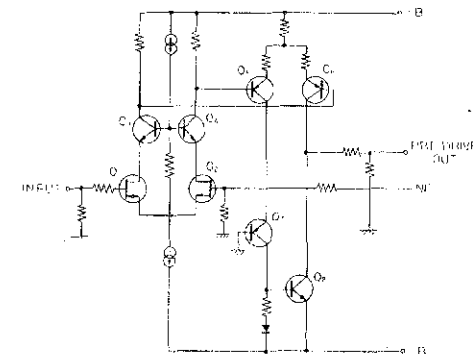

Center Potential Drift

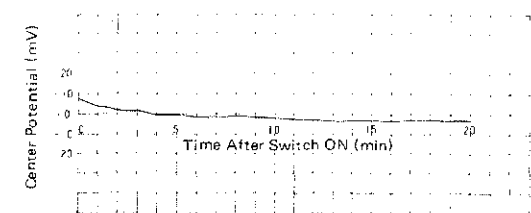

CASCODE-BOOSTRAP CIRCUIT

Conventional amplifier design has often resulted in degraded distortion when signal source impedance rises, particularly when the input volume control is reduced below maximum. This is due to the non-linear variation in spurious input signal generated by the small collector-base current which flows in transistors (drain-gate current in FETs) in the input stage. The current varies with the drain-gate potential, so that high impedance sources were subject to increased distortion.

In the B-2, this problem has been completely solved by the use of a first stage differential amplifier with cascode-bootstrap circuit configuration. This holds the drain-gate potential steady, so that there is no increase in distortion with increasing input impedance. Adequate gain and low distortion are further secured by the following pre-drive current-mirror differential amplifier with push-pull class A operation.

Reduction in Distortion Due to Cascode Bootstrap Circuit

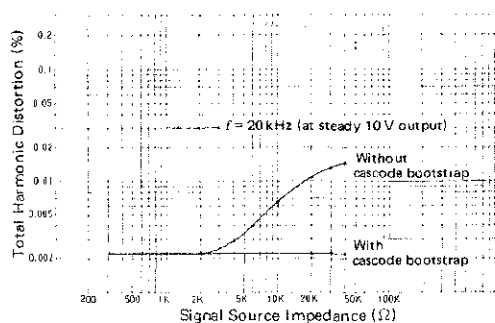

DRIVE AND OUTPUT STAGES

Because FETs are essentially voltage-amplifier elements, they have higher input impedances, and do not require the high power drive of bi-polar transistors. However, electrical power is required for the charge and discharge of the gate to source input capacity. The highest possible high frequency response will be assured by minimizing the time constant of the FET input capacity plus the drive impedance. The symmetrical push-pull drive circuit adopted in the B-2 is outstandingly effective.

Power Amplification Stage

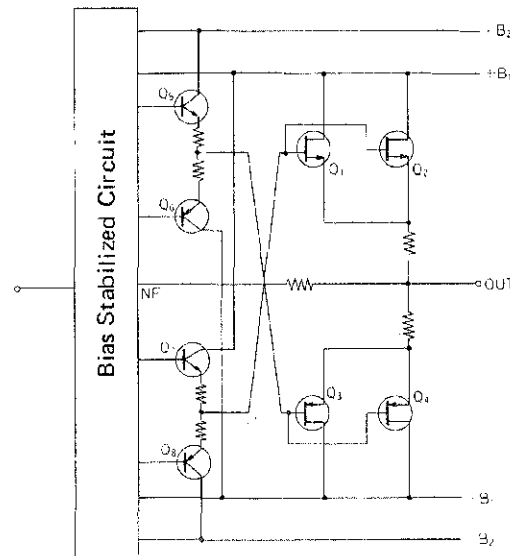

SYMMETRICAL PUSH-PULL DRIVE

'Symmetrical push-pull' involves the use of P-ch and N-ch FETs in the power stage in a fully complementary push-pull drive circuit configuration. It has the following advantages:

1. In contrast with emitter-follower circuitry, the drive impedance is the same in both ON and OFF states, and can be considerably reduced.
2. For frequencies in or near the audio band, FET input impedance is high, so that little current is required in the drive stage. At much higher frequencies, however, the input capacity requires class B operation, but the advantages of (1) above are retained. (With emitter-follower circuitry, any attempt to reduce the drive impedance involves reducing the emitter resistance, so that large currents must flow.)
3. With low requirements for drive stage current, transistors with small P_C can be used. The B-2 uses the same transistors as are used in the pre-drive stage, with a maximum P_C of approximately 1 Watt, making possible high h_{fe} and f_t , the mark of a fine pre-drive design.

YAMAHA SUPER-PAIR FET OUTPUT STAGE

The output stage uses two of the YAMAHA special super-pairs of FETs in a fully complementary parallel push-pull OCL circuit. The special pairing selection procedure gives FETs with extremely closely matched characteristics at low currents, so that from low power level outputs right up to very high power levels, for all frequencies, distortion is minimal. Large heat sinks are used, with separate units for left and right channels. No mica is used in the FETs, which are directly attached by a special process to the heat sinks, giving a thermal resistance less than half that of conventional mica construction, and ensuring effective heat dissipation.

The graph of output power against total harmonic distortion shows that distortion is less than 0.005% from 4 Watts to 100 Watts at 20Hz and 1kHz. Even at 20kHz, distortion is still less than 0.008% from 1 Watt to 60 Watts. These figures put the B-2 right at the front of the current state-of-the-art in power amplifier performance.

A comparison of the sine-wave and distortion waveforms at 20Hz and 20kHz shows clearly how cross-over distortion has been virtually eliminated, giving smooth waveforms and superior low distortion performance. Inspection of the noise spectrum as revealed by spectral analyzer for a 10kHz signal fails to reveal any visible harmonic distortion at all. Referring again to the 20Hz waveform, note the absence of ripple content.

Frequency vs. Total Harmonic Distortion

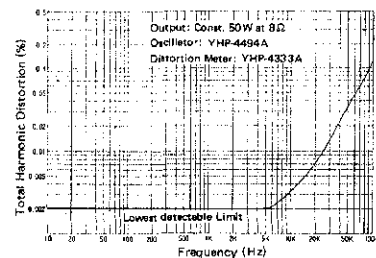

Output Power vs. Total Harmonic Distortion

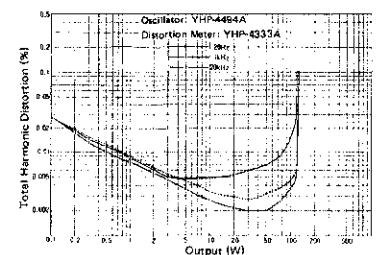

20Hz Sine Wave Distortion Waveform

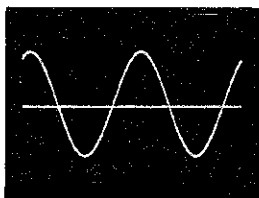

20kHz Sine Wave Distortion Waveform

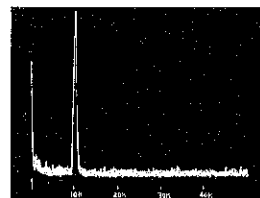

Noise Spectrum as Revealed by Spectral Analyzer

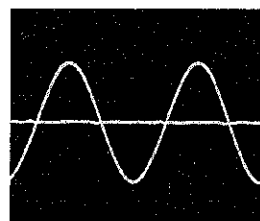

SUPERB PERFORMANCE IN EVERY RESPECT

The graph of power bandwidth shows the response from DC to 100kHz (3 dB below the rated maximum output, with 0.1% total harmonic distortion). This wide response, due in part to the symmetrical drive amplifier circuitry and the inherently high switching rate of vertical FETs, is also evident in the slew rate. An extremely high 60 volts per microsecond, the slew rate promises what is so soon evident upon hearing the B-2: a truly dynamic transient response, with every sudden climax crisp and powerful.

Operated in the DC mode, phase deviation is negligible down to DC. The presence of the input capacitor in the NORMAL mode causes the slight phase deviation of $+40^\circ$ at 10Hz. In both DC and NORMAL modes, deviation is only -30° even at 100kHz. The result is to assure the waveform transmission fidelity illustrated in the accompanying photographs for square waves and tone bursts. The upper waveform in each case is the original, the lower, that reproduced by the B-2.

First note the virtually identical tone-burst response at 10Hz and 10kHz. The 10Hz response, and that for the 10Hz square wave, too, are almost perfect duplications of the original waveform, indicating the superiority of the B-2 DC amplifier. Superior high frequency performance is just as clearly indicated in the 10kHz tone-burst and square-wave response. Stability, too, is outstanding even with a $0.1\mu\text{F}$ capacitor across the 8-ohm load.

Power Bandwidth

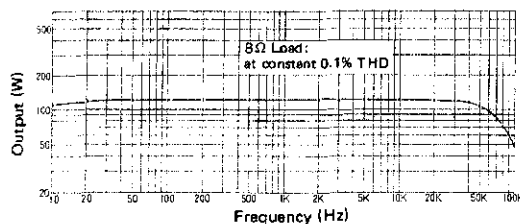

Phase Deviation vs. Frequency

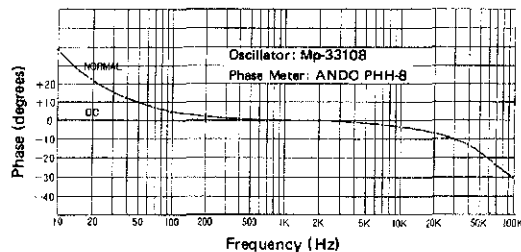

Slew Rate

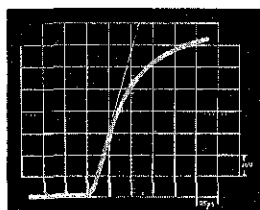

10 Hz Tone Burst and B-2 Response

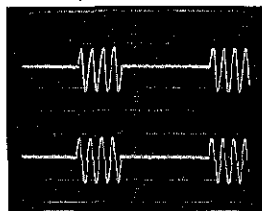

10 Hz Square Wave and B-2 Response



10 kHz Tone Burst and B-2 Response

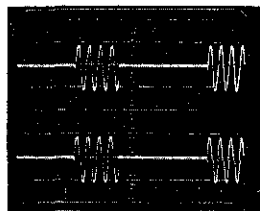

1 kHz Square Wave and B-2 Response

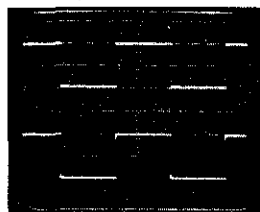

10 kHz Square Wave and B-2 Response

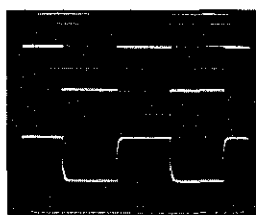

10 kHz Square Wave Response With 0.1 μF Capacitor Across 8 Ω Load

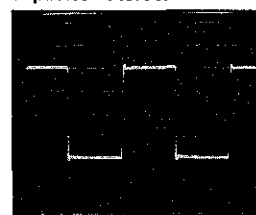

INDEPENDENT L/R POWER SUPPLIES

YAMAHA was the first company in Japan to use separate transformers for the left and right channels of a power amplifier (the famous B-1). The B-2 features the same arrangement and, to ensure that cross-talk between the two channels is minimized, each channel uses two 18,000 μ F electrolytic capacitors (a total of 72,000 μ F in all). This lifts low frequency response at high power levels to the highest possible quality. A full and powerful bass reproduction is one of the fundamental features of this amplifier. Also, the use of regulated voltage power supplies to the

stages before the drive stage, too, with the elimination of deterioration in S/N ratio due to external noise sources and ripple, is one of the secrets of the extreme stability of amplifier operation.

AUTOMATIC BIAS AND PROTECTIVE CIRCUITS

Bias is automatically maintained at the optimum level despite changes in electrical supply voltage by a special bias circuit. The protective circuits include:

1. Diode matrix to protect FETs from high 'rush' currents when switching ON.
2. P_D limiter FET protection: detects excessive FET current/voltage and reduces input level if load impedance drops below 2 ohms with more than 50 Watts output.
3. DC limiter speaker protection: detects DC at the speaker terminals and isolates them immediately by relay. This also mutes the speakers immediately after switching ON, to eliminate the shock noise associated with initial instability.
4. Thermal trip protection for transformers: detects abnormal temperature rise and operates circuit breakers to switch power OFF. Resetting is automatic as soon as the temperature drops within the permissible range.

Other measures taken to ensure long term operating reliability include the choice of circuit components with high temperature stability (drift of center potential is less than ± 10 mV from 0° to 50° C) and gold-plated sliding contacts, etc.

B-2

BLOCK DIAGRAM

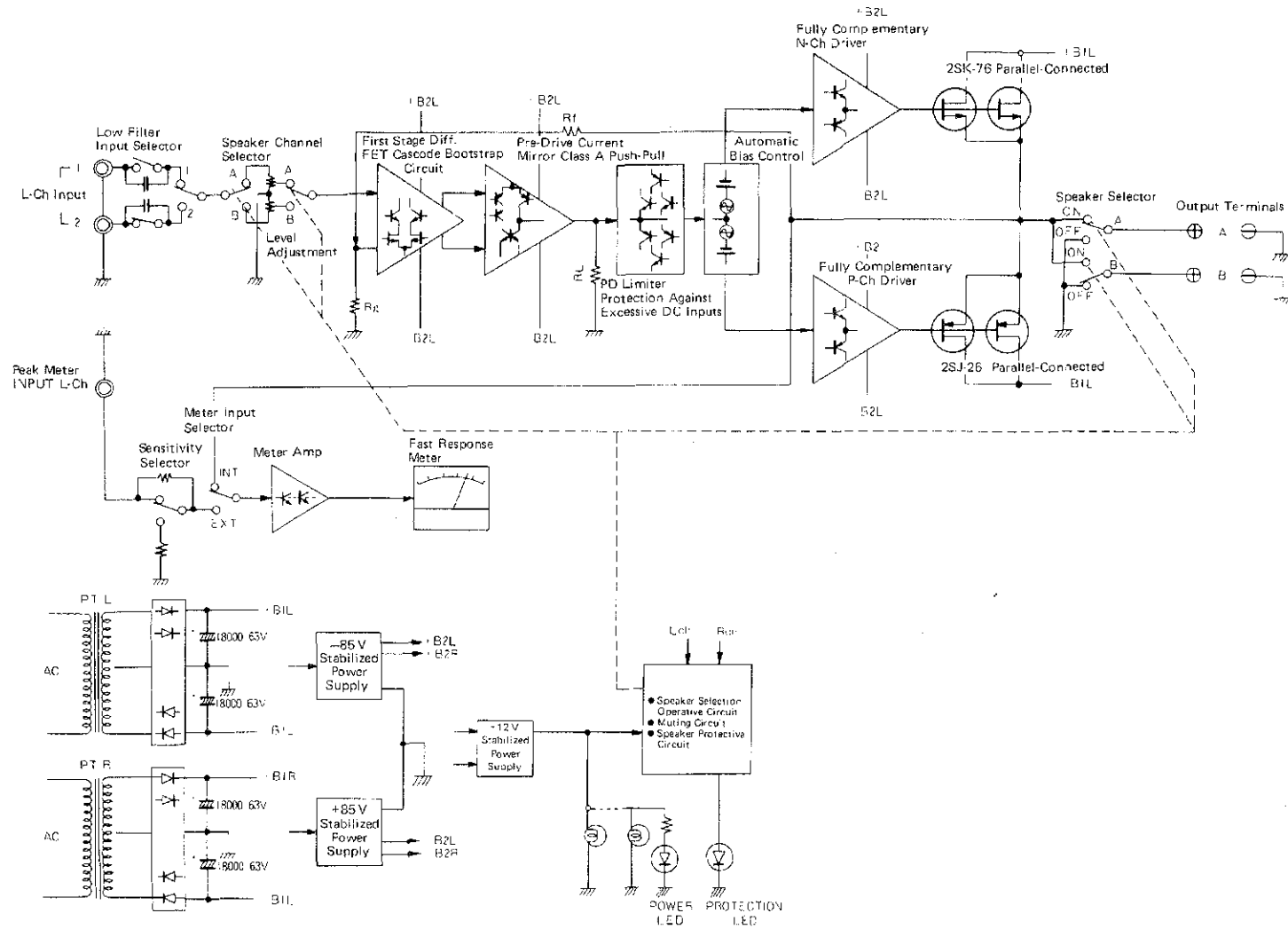

B-2

SPECIFICATIONS

Power Amplifier Section

| Feature | Conditions | Specification |
|---------------------------|--|--|
| Dynamic Power | 8 Ω , 1kHz, 0.1% THD | 140 + 140 Watts |
| Rated Power | 8 Ω , 20Hz to 20kHz 0.08% THD | 100 + 100 Watts |
| | 4 Ω , 20Hz to 20kHz 0.08% THD | 140 + 140 Watts |
| Phase Deviation | DC to 100kHz, (at 10 Watts) | +0 to -30° |
| Power Bandwidth | 3dB down, at 0.5% THD, 8 Ω | 5 Hz to 100kHz (IHF) |
| Damping Factor | 20Hz 8 Ω | 70 |
| | 1kHz 8 Ω | 70 |
| | 20kHz 8 Ω | 50 |
| Total Harmonic Distortion | 20Hz to 20kHz, rated output 8 Ω | Less than 0.08% |
| | 20Hz to 20kHz, 50 Watts output 8 Ω | Less than 0.01% |
| | 20Hz to 20kHz, 10 Watts output 8 Ω | Less than 0.008% |
| Intermodulation Dist. | 70Hz : 7kHz = 4 : 1 at 50W, 8 Ω | Less than 0.03% |
| | 70Hz : 7kHz = 4 : 1 at 50W, 4 Ω | Less than 0.03% |
| | 70Hz : 7kHz = 4 : 1 at 50W, 16 Ω | Less than 0.03% |
| Frequency Response | 1 Watt output, 8 Ω , DC setting | DC to 100kHz $\pm 1^0$ dB |
| | 1 Watt output, 8 Ω , NORMAL setting | 10Hz to 100kHz $\pm 1^0$ dB |
| Input Impedance | | 25 k Ω |
| Input Sensitivity | | 775mV |
| Signal-to-Noise | IHF-A, 4.7k Ω input short | 115dB |
| Residual Noise | | 0.25mV |
| Input Terminals | | 1, 2 (front panel switch) NORMAL/DC (Rear panel switch) |
| Output Terminals | | A, B (Rear panel switch) |

Peak Meter Section

| Feature | Specification |
|-----------------------------|---|
| Meter Range | -50 to +5dB (0dB = 8 Ω /100W or 0dBm) |
| Accuracy | +5 to -20dB ± 1.0 dB |
| | -20 to -40dB ± 2.0 dB |
| | -40 to -50dB ± 3.0 dB |
| Frequency Response | 20Hz to 20kHz ± 1.0 dB |
| Rise/Decay Time | 100 μ sec/1 sec |
| Input Terminals | RCA pin jacks for EXTERNAL |
| Indicator Switch | INTERNAL/EXTERNAL on rear panel |
| Sensitivity/Input Impedance | 0 dB = 8 Ω /100 Watts (INTERNAL) |
| | 0 dB = 8 Ω /100 Watts/100k Ω } (EXTERNAL) |
| | 0 dB = 0 dBm/43k Ω } |

General

| | |
|------------------------|--|
| Semiconductors | 8 Vertical FETs, 4 Horizontal FETs 95 Bi-polar Transistors, 2 ICs, and 66 Diodes (including LEDs). |
| Power Supplies | U.S.A. & Canada AC 120V, 60Hz Other areas AC 220/240V, 50/60Hz |
| Power Consumption | 290W |
| Dimensions (W x H x D) | 436 mm x 370 mm x 151 mm (17-1/8") (14-5/8") (6") |
| Weight | 26kg (57 lb 3 oz) |

Specifications subject to change without notice.

B-2

TROUBLE SHOOTING

Before assuming that your B-2 is malfunctioning, check the following trouble-shooting list.

| Fault | Cause | Cure |
|---|--|--|
| No sound from left- or right-hand speaker or both. | Unsatisfactory speaker connections. Speaker level control(s) are turned down to minimum. Speaker selector switch in wrong position. Unsatisfactory input connections. Input selector in wrong position. | Check and make good all speaker connections. Slowly turn level control knobs up (clockwise). Push the button to select the correct speaker position. Plug all input pin-plugs firmly into position. Push the button to select the correct input source. |
| Sound is cut off during audition. | Speaker protective circuit operative ($\pm 2V$ DC detected at speaker terminals: the PROTECTION LED will light). Transformer thermal trip operative (overheating: the PROTECTION LED will light). FET protective circuit operative (short-circuit or too low speaker impedance: PROTECTION LED will light). Power fuse has blown (POWER LED goes out). | Wait until the DC clears or switch over to NORMAL mode if you were operating in the DC mode. Wait until the B-2 cools down, switching OFF the power. Also check ventilation adequacy. Switch OFF and check for short circuit in speaker leads or unsuitable speaker impedance (below 4 ohms). Unplug and contact your local service representative. |
| Poor bass response and badly defined stereo image. | Speaker phase polarity (\pm connections) incorrect. | Reverse the connections to one speaker (not both). |
| A loud 'humming' is heard instead of the record when attempting phono audition. | Either the pin-plugs from the phono cartridge are not plugged-firmly into the preamplifier input sockets, or the braided shielding wire is defective. | Plug in phono cartridge pin-plugs firmly, replacing the faulty shielding if necessary. |
| The volume cannot be raised during record audition without a loud 'booming' sound. | This 'howling' is caused by acoustic feedback from the speakers to the phono cartridge stylus. | Increase the separation between turntable unit and speakers, avoiding locations directly in line with the speakers. Acoustic insulators can also help. |
| Meters do not indicate B-2 output levels (or external equipment input levels). | The meter input switch on the rear panel is at EXTERNAL (or INTERNAL). | Switch to INTERNAL (or EXTERNAL as the case may be). |

SINCE 1887



YAMAHA

NIPPON GAKKI CO., LTD., HAMAMATSU, JAPAN