

Schematic - No. 207 Power Amplifier

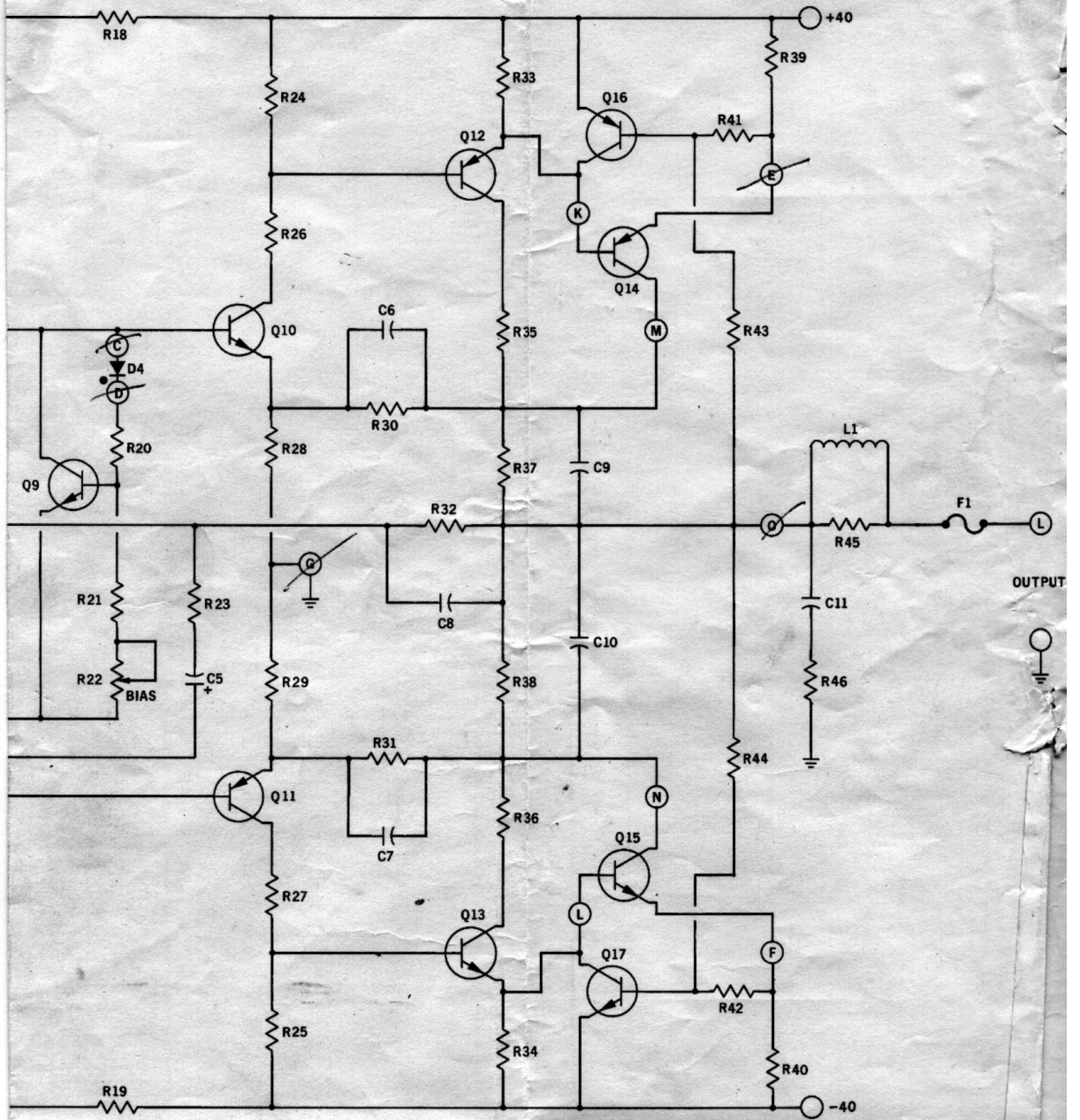

Power Supply And Meter Circuit - No. 207
Power Amplifier

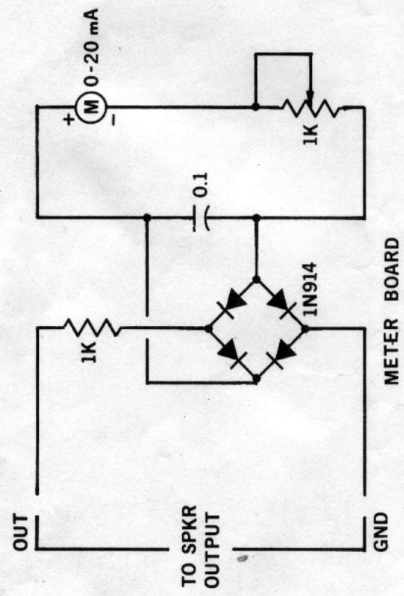

METER BOARD

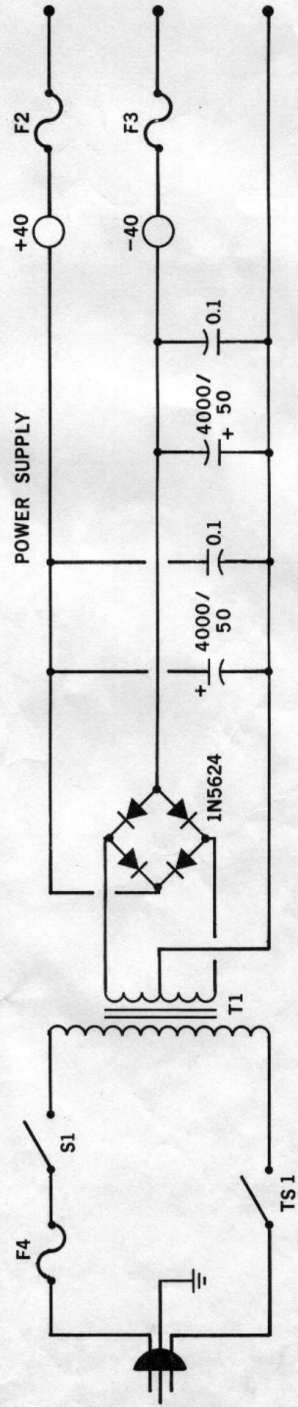

Instructions - #207/A Power Amplifier

The #207/A Power Amplifier is a 60 watt, low distortion, low noise, single channel amplifier kit designed for audio applications.

The circuit must be assembled with great care. Even a minor error can cause costly damage, so follow the instructions exactly and check over all assembly steps before applying power to the unit.

Circuit Board Assembly

- (1) Clean the foil side of the #207 circuit board with steel wool to remove all traces of copper oxide. Wash and dry the board thoroughly afterward to remove all traces of the conductive steel wool.
- (1) Insert the resistors in the #207 board. Be sure to note that resistors R45, R46, and R47 are not mounted on this board. As with all other component installation unless otherwise noted, use the parts list and the printing on the component side of the board to locate the proper location for each part. Mount the component flush with the top of the board, bend the leads on the back side of the board parallel with the bottom of the board and trim so that 1/16" to 1/8" of wire remains. Do not solder any of the connections until all of the circuit board components have been installed.
- * (1) Insert the capacitors in the #207 board. Be sure to note that capacitors C11 and C12 are not mounted on this board. Be sure to orientate the electrolytic capacitors so the polarity indicated on the capacitors agrees with that indicated on the circuit board.
- (1) Install the semiconductors on the #207 board. Be sure to orientate all of the diodes and transistors so their orientation agrees with that indicated on the component side of the circuit board and leave about 1/8" between the bottom of each of the small plastic transistor cases and the top of the board. Note that transistors Q14, Q15 and diode D4 are not mounted on the circuit board.
- (1) Attach the two jumpers to the #207 board. The jumpers are indicated by the solid lines connecting pads printed on the component side of the circuit board and can be made by using some of the excess resistor lead trimmed off when installing the resistors.
- (1) Solder all of the connections on the #207 board using a 30 to 50 watt iron and the solder supplied with the kit or an equivalent 60/40 alloy resin core solder. Do Not use acid core solder, or any type of soldering paste. Doing so voids our warranty.

Heat Sink Assembly

- (1) Coat both sides of the two mica insulating washers with a thin coat of the heatsink compound supplied with the kit. Place each washer over transistor Q14 and Q15.

- (1) Insert the compensating diode D4 into its clip and orientate the diode so the red dot is farthest away from the side of the clip with the mounting hole in it.
- (1) Place the two radial finned heatsinks over the heatsink bracket so the bracket is actually sandwiched between the two heatsinks. Be sure the transistor hole patterns of all three pieces line up.
- (1) Insert transistors Q14 and Q15 into the heatsink package from what will be the externally visible side of the heatsink assembly. Be sure you have put the right transistor in the right set of holes. Secure the transistor with #6-32 X 1" screws, insulated shoulder washers, lockwashers and nuts. Be sure to attach the two ground lugs, diode D4 assembly, and the 3 terminal lug strip between the shoulder washer and the lockwasher on the mounting screws indicated in the wiring diagram pictorial. NOTE: The case of each power transistor is electrically the transistor collector junction and hence must be electrically isolated from all other electrical junctions including the chassis. This is why the power transistors are insulated from the heatsink by the mica insulating washers and the shoulder washers. The mounting screws however are electrically connected to each transistor case and you must be sure the screws do not contact either the heatsinks or the mounting bracket as they pass through the assembly. If you are careful to line up the mounting holes in the two heatsinks and the heatsink bracket before securing the transistor mounting screws there should be no problem. Keep in mind also the base and emitter leads of each power transistor must be centered in the large holes through which they pass.
- (1) Attach the thermal switch TS1 to the heatsink assembly from what will be the externally visible side of the bracket. Orientate the switch as shown in the wiring diagram chassis pictorial and secure with #4-40 x 1/4" screws, lockwashers and nuts.
- (1) Attach the diode D4's leads to the lug strip. The lead with the red dot must connect to lug A while the other lead must connect to lug B.

Chassis Assembly

- (1) Attach the following to the rear of the main chassis: Fuseholders F1 - F4, jacks J1 - J4, and resistor R47. The fuseholders should be attached with the rubber washer on the outside of the chassis and the metal washer on the inside of the chassis and the metal washer on the inside of the chassis. Jacks J1 and J2 are the RCA type with a ground lug attached under J1. Jacks J3 and J4 are binding posts with J3 being yellow. Resistor R47 should be mounted with a flat washer on the outside of the chassis and a lockwasher on the inside. Be sure to orientate each component so the lug orientation agrees with that shown in the chassis pictorial of the wiring diagram.
- (1) Attach the lug strip LS1 and two 4000 ufd @50 VDC electrolytic capacitors to the chassis. The lug strip is secured to the chassis using a #6-32 x 1/4" screw, lockwasher and nut. The electrolytic capacitors are secured by capacitor clamps with #6-32 x 3/8" screws, lockwashers and nuts. The clamps in turn are secured by #6-32 x 1/4" screws, lockwashers and nuts. Here again orientate the lug,

strip and capacitors as shown in the chassis pictorial of the wiring diagram. the capacitors are polarized and their polarity markings must agree with those in the pictorial.

- (1) Attach the heatsink assembly to the chassis. Orientate the assembly so the heatsinks are toward the side of the chassis where the lug strip is attached and secure the assembly with #6-32 x 1/4" screws, lockwashers and nuts.
- (1) Attach the power transformer, T1, to the chassis. Orientate the transformer so the leads are toward the large electrolytic capacitors and secure it using #8-32 x 3/8" screws, flatwashers, and nuts.
- (1) Clean the foil side of the #PB board using the same procedure used on the #207 board.
- (1) Mount all of the parts on the PB board. The component values or numbers are printed on the component side of the board. The diodes indicated on the board are 1N5624's. Be sure to orientate these as indicated on the circuit board. Bend, trim, and solder all of the component leads except those of the two 0.1 ufd capacitors running parallel with the length of the board.
- (1) Place this board along side of the lugs of the two 4000 ufd @50 VDC electrolytic capacitors as shown in the photographs, wrap the 0.1 ufd capacitor leads around the adjacent lugs of the 4000 ufd capacitors, trim the excess leads and solder. Be sure the solder secures the capacitor lug to PB board copper foil connecting strip. NOTE: It should be made clear that the can of the 4000 ufd capacitors supplied with the kit is electrically neutral. No connections need be made to any of the external can twist lugs on either capacitor.
- (1) Strip about 2" of the heavy insulation off of the bare end of the line cord. Strip an additional 1/2" off of each of the three exposed wires. Crimp the strain relief onto the line cord about 3" from the end of the cord's wires with a pair of pliers. While compressing the strain relief with the pliers, insert the wires into the hole provided at the rear of the chassis and release.
- (1) Temporarily attach power switch S1 to the chassis and insert the red lamp cover into the chassis. Do not put the retaining clip on the lamp cover. Snap the neon lamp, I1 into the lamp cover.
- (1) Attach and solder resistor R-11, and 82K ohm 1/2 watt 10% resistor in series with one of the neon lamp I1, leads.

Wiring Procedure

- (1) Complete wiring steps 1 through .9 using the wiring table and wiring diagram. Slip a piece of heat shrinkable tubing over each of the leads of neon lamp I1 when attaching the wires. Shrink the tubing with your soldering iron after attaching the wires.

- (1) Insert fuses F1 thru F4 using the parts list to obtain the correct value of each fuse.
- (1) Insert the line cord plug into a wall outlet and using a multimeter, measure the DC voltage at the +40 and -40 volt terminals with respect to the GND terminal on the PB board. The red lamp on the front of the chassis is an overheat indicator not an on-off indicator so do not expect the lamp to light on this or any other of the tests to come. If the voltages are not within 10% do not continue assembly until the apparent problem is corrected. Unplug the unit.
- (1) Complete wiring steps, 10 through 17 of the wiring table. Inductor L1 is one close wound layer of enameled wire on the body of resistor R45. Be sure to scrape some of the enamel from each end of the wire before trying to solder the ends to the leads of resistor R45. Capacitor C12 is a tantalum electrolytic, however the DC potential across it should be zero making polarity orientation unnecessary.
- (1) Complete wiring steps 18 through 31 of the wiring table. For this part, cut, strip and attach all of the wires to the #207 board first then go back and complete the second half of each step. Attach and solder the press on clips to the base and emitter wires for the two power transistors, but do not connect these wires to the bases and emitters until after an upcoming preliminary check-out procedure. Solder all wires to the foil side of the 207 board and note that point G is located between R37 and R38 and is obscured from view.
- (1) Snap the two #6 tinnerman nuts in the circuit board mounting holes on the heatsink bracket.
- () Pull the four pin-tipped base-emitter wires up toward what will be the top of the chassis and secure the board using #6-32 x 1/4" screws.
- () At this point, all wiring should be completed excluding connections to the meter and its board and the power transistor base and emitter wires. Check all connections over to be sure all connections have been soldered.
- (1) Set the idle current control, resistor R22 so the tab on the knurl of the control is toward the bottom of the chassis, and turn the level control shaft, resistor, R47, fully counterclockwise.
- (1) Insert the line cord plug into a wall outlet and using a multimeter, measure the DC voltage across the speaker terminals. It should be less than 0.1 volts DC plus or minus. Also measure the voltage drop across resistors R35 and R36. Neither reading should be higher than 0.6 volts DC. If the voltages are not within the specified limits, do not continue assembly until the apparent problem is corrected. Unplug the unit.
- (1) Remove the #6-32 x 1/4" board mounting screws and pull the board back away from the chassis.

- () Attach the four power transistor base and emitter leads making sure the leads are well insulated from any possible contacting metallic surfaces.
- () Position and reattach the circuit board using #6-32 x 1/4" screws and lock-washers. Attach your multimeter to the output jacks of the amplifier with the meter's range switch set around the 0 to 10 volt DC position. Again insert the line cord plug into a wall outlet. The meter will probably deflect slightly at turn-on, however, if the needle does not return to zero volts within a second or so, remove power immediately and locate the problem before proceeding. If the voltage measurement is close to zero, increase the sensitivity of the meter and check to make sure the actual voltage is less than 0.05 volts DC plus or minus. If this reading is within limits remove power and continue.
- () Remove the power switch, S1, and the lamp, I1, along with the lamp cover from the chassis.
- () Mount the front panel to the chassis using contact cement (not supplied). Follow the directions on the contact cement and be sure not to get any on the panel lettering.
- () Reattach the power switch, lamp cover and lamp I1 to the front panel. Adjust the rear retaining nut of switch, S1, so there are just enough threads on the front panel side to secure the switch. Use the retaining clip to hold the lamp cover in place.
- () Clean the meter circuit board using the procedure followed on the #207 circuit board.
- () Attach and solder all of the components to the board. The small diodes are 1N914's. Be sure to orientate these as indicated by the printing on the component side of the board.
- () Solder a left over resistor lead to each of the two pads indicated by the letter "M". These leads will be used to secure the board to the meter terminals.
- () Now that the front panel has been attached to the chassis, the unit will be more difficult to handle since it will not set flat, so be very careful.
- () Attach the meter to the chassis. Use the retaining clip to hold it in place.
- () Now attach the meter circuit board with all of its components to the meter terminals. Orientate the board as shown in the photographs.
- () Complete wiring step 32. Attach the twisted pair to the pads of the meter board indicated in the wiring diagram; It does not really matter which wire is connected to which pad since the output of the amplifier is an AC voltage.
- () Snap the tinnerman nuts into what will be the cover mounting holes.

- () Press the level control knob onto the control shaft.

Final Calibration

For minimum possible distortion, the idle current control, resistor R22, should be set to its optimum position, however, to do this, you will need a voltmeter capable of reading down to 40 millivolts DC.

Connect the positive lead of your meter to point "M" and the negative lead to point "N" on the #207 circuit board and make sure the idle control is still set so the tab on the knurl of the control is toward the bottom of the chassis. Insert the line cord plug into a wall outlet and allow the amplifier to idle for five minutes. Now advance the idle current control, resistor R-22, until the voltage reading is 40 millivolts DC. Remove power and disconnect the meter leads.

If you do not have a meter capable of readings to 40 millivolts, leave the idle current control set so that the tab on the knurl of the control is toward the bottom of the chassis. Advancing the control past the 40 millivolt voltage drop position can cause thermal instability of the amplifier.

The other control which should be adjusted is the level meter calibration potentiometer which is mounted on the meter board. To set the control, connect an audio sine wave generator to the input of the amplifier and set the frequency control knob to 1 KHz. Connect an AC voltmeter across the output jacks of the amplifier and turn the level control on the amplifier fully clockwise. Insert the line cord plug into a wall outlet and set the level control of the audio generator for an output voltage of 23 volts RMS if the amp is to be used with an 8 ohm system, 26 volts if the amp is to be used with a 16 ohm system and 17 volts if the amp is to be used with a 4 ohm system. Then set the meter board trimmer resistor so the "% MAX POWER" meter reads 100%. Install the cover on the unit.

Operation

The 207/A amplifier is a high quality unit and in order to maintain its outstanding performance there are several things the owner should be made aware of.

The chassis layout, grounding location, and wiring lengths on this as well as on other high gain wide band amplifiers is critical. It is therefore recommended that the amplifier not be built on any chassis other than that supplied with our kit. The amplifier has also been designed to operate on ± 40 VDC @ $3A \pm 10\%$ power supply. Any deviation from these figures is not recommended and the outcome cannot be predicted.

The amplifier has been designed to operate as an audio frequency amplifier although it does have wide-band capabilities. Continuous high level operation, high frequency operation, or low air flow environments can cause overheating which will be indicated by the thermal switch TSI cutting the power to the amplifier and

turning on the overheat indicator lamp, I1. Never operate the amplifier continuously at a frequency higher than 30 KHz and an output voltage level greater than 1 volt RMS. If there is a sign of overheating the user can provide for additional fan cooling which should alleviate the problem.

Never make any input or output connections to the amplifier with the power on. A floating ground can easily damage your amplifier and/or speaker system. Also note the amplifier is provided with an AC and DC inputs. If you are absolutely sure your preamp has no DC component on the output you can use the DC input, otherwise use the AC input on the amplifier.

The maximum output level of this amplifier is slightly over 60 watts into an 8 ohm load which is far too much power for many speaker systems. If your speaker system cannot handle the power, you could damage a speaker, so reduce the amperage of the speaker fuse, F1. The fuse amperage should proportionately lower for lower power speaker systems.

If desired the amplifier may be wired to operate from 220 volts AC rather than 110 volts AC. Just remove the red wire with the black tracer and brown wire from their present connections. Connect these two wires together and solder. The amp is now wired for 220 volt operation.

In Case of Problems

The tests called for in the assembly instructions are designed to warn you of problems before they can cause serious problems, or damage. If any abnormal results are obtained during these tests, or there is obvious overheating of any part, do not continue assembly until the cause of the problem is located and corrected. Experience has shown that most problems are caused by minor wiring, component installation, and soldering technique errors which can be prevented by careful assembly. Should any unsolvable problem occur, consult the company staff before returning the kit for repair.

Symptoms like burning resistors or over heated components do not necessarily mean that the particular component(s) in question is at fault. These symptoms are usually caused by another unsuspected error or component failure. This is one reason we do not supply a schematic with typical voltage measurements on it. The circuit uses 100% DC coupling and failure or error in any portion of the circuit will cause almost all voltage readings to vary making it almost impossible to pinpoint the problem.

Should it appear there has been a component failure, the most likely element would be one of the transistors. These devices quite often go out in a chain reaction which will blow out several at once after one has failed, so check all of the transistors for opens and shorts. Also check the 2 watt power resistors on the board as well as all of the fuses for possible open circuits, and be sure to replace any charred resistors.

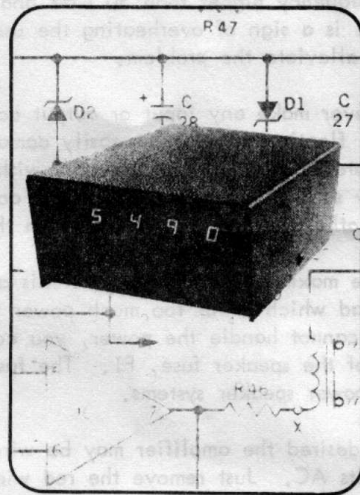
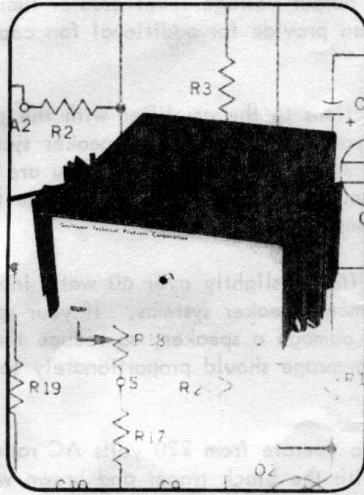

HEADSET AMPLIFIER

DESIGNED SPECIFICALLY TO DRIVE
HEADSETS

CLASS A OPERATION - LOW
DISTORTION AT ANY LEVEL

FLAT + 0.5 DB 10 to 100,000 Hz

At last an amplifier designed specifically for driving a headset. This amplifier has all of the features found in the best power amplifiers, but provides a power output suitable for driving headsets safely. This amplifier will deliver 2 Watts per channel of ultra clean class A power with a damping factor greater than 20 into an 8 - 16 Ohm headset.

Construction is easy. All parts except transformers and connection jacks mount on two of our fiberglass circuit boards. The 7x8x3 1/2 deep case is finished in a beautiful new dusky chrome and has a black vinyl covered steel top.

202-C Headset Amplifier Kit

Shipping Weight 7 lbs. \$44.50

DIGITAL TACHOMETER

400 to 9,990 RPM WITH NO RANGE
CHANGING

4 DIGIT LED READOUT

WORKS WITH 4, 6 OR 8 CYLINDER
ENGINES

Our high accuracy digital readout tachometer. This instrument measures your engines RPM ten times a second and displays it on four bright red 0.3 inch high LED readouts.

Only three wire connections in the whole kit. The Tachometer is housed in an attractive black vinyl covered aluminum box 4 1/2 by 2 1/2 high by 7 inches deep. May be mounted on top of, or under the dash in your car. Simple hookup - only +12 volts, ground and distributor point connections are needed.

TACH-1 Kit. Shipping weight 3.0 lbs. \$79.50



Southwest Technical Products Corporation, 219 W. Rhapsody, San Antonio, Texas



BUILD 4-CHANNEL POWER AMPLIFIER

Unbelievably low distortion is a feature of this four-channel amplifier for quadraphonic applications. Each channel drives an 8-ohm load at up to 60 watts rms.

by DANIEL MEYER

TIGER .01 IS MY LATEST EFFORT TO PRODUCE A BETTER audio power amplifier. With this design, distortion is reduced to a level of less than .01% at any power level up to rated output. With distortion products pushed down to a level more than 80 dB below the program material, it is very tempting to announce that this is the ultimate and that no further improvement in amplifiers will ever again be necessary.

Since the same thing was said when amplifier distortion was reduced to 5%, then 1% and finally to 0.1% and each time has been proven false, we will simply have to await improvements in other components to a comparable level of distortion before we can know for sure, but don't take any bets. The ear has proven to be considerably more sensitive to such things than anyone imagined ten or twenty years ago.

Like most things, the *Tiger .01* circuit has evolved slowly over a number of years with small, but steady improvements. It is usually possible to consider a power amplifier as consisting of two parts; the input, or voltage amplifier portion and the output, or matching portion. The point of division is obvious in most circuits, since the portion following the bias system is the output portion.

Except for car radios and a few other low/power special cases almost all development effort has been toward perfecting the class AB, or B type circuits. Class-A circuits

are only practical for power outputs up to approximately 10 or 12 watts. Beyond this point the high quiescent power dissipation caused by low efficiency of class A-circuit discourages serious attempts at more powerful circuits.

The advantages of complementary class-AB and class-B amplifiers have been known for at least twenty years.¹ Most of the complementary circuits in use today are described in this paper. High-power complementary transistors were not available at this time though, and the few germanium npn types that could be obtained were terribly expensive. This led to wide use of quasi-complementary circuits in which only one polarity of output transistor is used with a complementary driver pair as in Fig. 1.

This type circuit presents a number of problems. First, the output stage must operate at unity gain, since (in the form shown here) the positive half cycle of the signal passes through a pair of emitter followers that cannot provide any gain. In addition, the circuit inherently has greater distortion than a complementary circuit due to the different number of junctions in the signal path on positive and negative half cycles and the difference in input impedance of the upper and lower pairs. Despite all of this, the quasi-complementary output circuit delivers reasonably good performance and is still widely used today.

Fully complementary output circuits became popular in the late '60's when reasonably priced complementary silicon transistors became available. Some of the best of these were the Marrantz 15 and the JBL "T" circuits. In 1967 the first of the present series, *Lil Tiger* was introduced. Although not designed to be the world's lowest distortion amplifier, this circuit gave quite respectable performance at minimum cost, due to the use of complementary plastic output transistors. In October 1970 the *Universal Tiger*² introduced a new variation in output circuits, an output stage with gain; see Fig. 2. You will note that that type circuit is completely complementary and also cannot be built without complementary transistors in the output stage. Using this type of output circuit reduces the drive voltage needed for the output section of the amplifier and also makes it possible to control the response of the output section very neatly by proper choice of capacitor C in the schematic.

The *Tiger .01* uses a similar output circuit, but with a

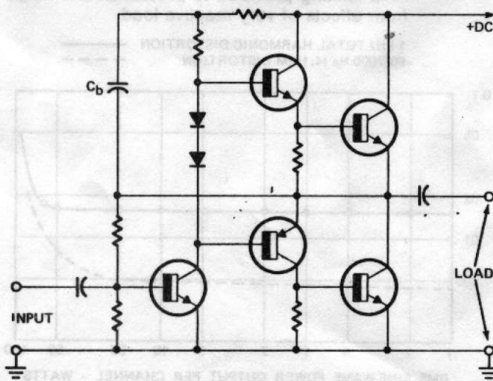

FIG. 1—QUASI-COMPLEMENTARY OUTPUT TRANSISTORS are driven by driver in complementary configuration.

1. G. C. Sziklai, "Symmetrical Properties of Transistors and Their Applications" Proceedings of the IRE, 41, 717-724 (1953)
2. "The Indestructible 125 Watt Power Amplifier," *Popular Electronics*, October, 1970

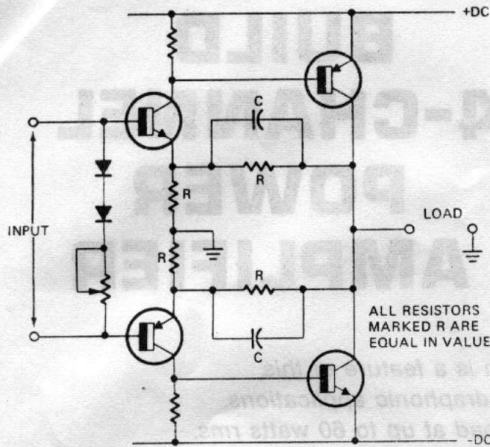

FIG. 2—OUTPUT STAGE WITH GAIN uses complementary transistors in circuit requiring relatively low drive voltage.

Darlington output; thereby making the output section of the circuit a triple. Doing this increases the current gain of the output section of the amplifier and further reduces the amount of drive current needed from the amplifier portion of the circuit. From this we get greatly reduced gain variation with signal output and can almost eliminate any need for matching of the complementary transistors.

The only problem with a triple is that temperature tracking of the bias and output stage is far more critical now. Feedback from current sensing resistors R37 and R38 to the first stage of the triple, Q10 and Q11, along with thermal compensation diode D4 takes care of this problem. Output feedback resistors R28 through R31 set the gain of the output triples at approximately three, so we have a very linear output section for our amplifier that only requires around 8 volts rms and a few milliamps to drive it to full output.

With the output section of the amplifier taken care of, the voltage amplifier portion can be considered. Most early power amplifiers and even a few current ones, used single-stage voltage amplifier and driver systems with a bootstrap collector load of the type shown in Fig. 1. Sometimes an additional impedance matching stage was added at the input to allow matching to tube preamps. Capacitor C_b allowed the amplifier to produce full positive supply output on signal peaks by adding the output voltage to the supply voltage at the junction of the two collector resistors. This type voltage amplifier does not lend itself to use with split power supplies and it is generally used with a single-ended power supply. Due to the half-supply voltage offset at the output the speaker must be coupled through a large capacitor.

This system normally has 20 some odd dB of negative feedback and will produce an amplifier with less than 1% distortion. The circuit can be improved and the amplifier can be used with a split supply, if the input stage is made a differential amplifier. This allows the input and feedback points at the two bases both to be referenced to ground and keeps the output point at dc ground. This is a considerable improvement since there are now two stages of gain, which allows more feedback to be used to lower distortion and the speaker now has no reactive components between it and the output of the amplifier. The entire amplifier may now be dc coupled if desired.

Another improvement is the use of a current source as the driver collector load instead of the bootstrap capacitor, split resistor system. This considerably reduces any cross-

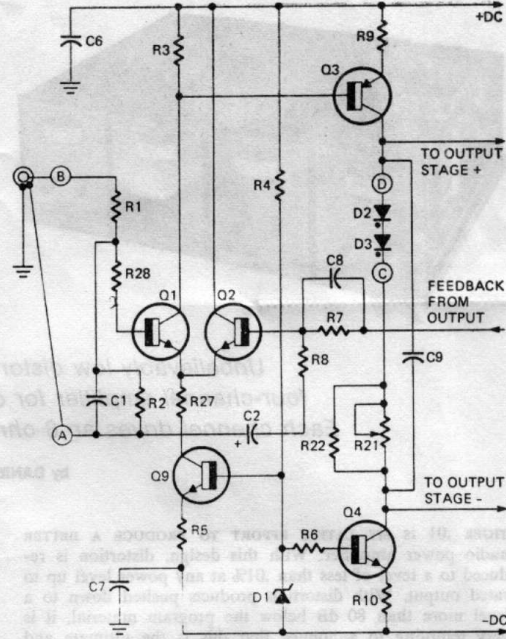

FIG. 3—CROSSOVER DISTORTION IS INHERENTLY LOW when current source replaces the driver bootstrap capacitor.

SPECIFICATIONS

Power Output—60 watts sine wave continuous; 8-ohm load.

Frequency Response—5.0 to 100,000 Hz at -1.0 dB points.

Distortion—Less than .01% IM distortion up to rated output. See graphs for complete distortion information.

Output Impedance—Less than 0.1-ohm 20 to 20,000 Hz.

Hum and Noise—More than 80 dB below full output.

Input Sensitivity—0.8 volts rms maximum for full rated output. Level control provided to reduce sensitivity if needed.

Stability—Completely stable with any type load. Volt-Amp limiting provided to protect output stage from effects of very reactive load.

1 kHz TOTAL HARMONIC DISTORTION ———
60/7000 Hz (4:1) IM DISTORTION - - - - -

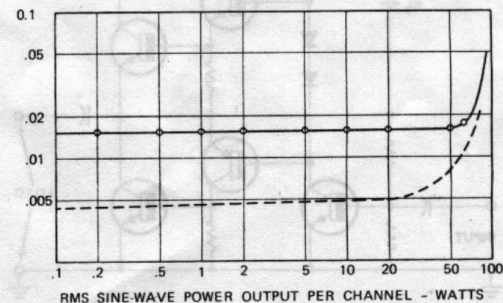

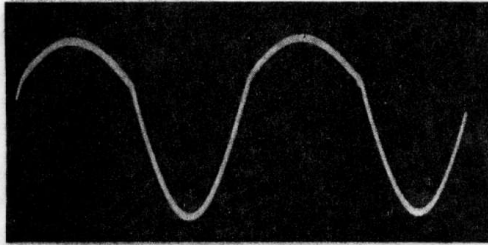
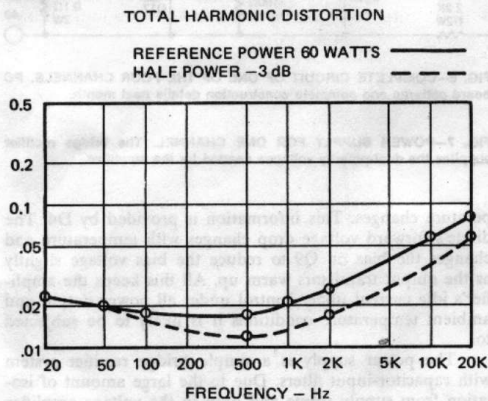

FIG. 4—DISTORTED WAVEFORM fed from collector of Q1 to the base of Q3. Effect of distortion is reduced by push-pull driver.

over notch distortion that may be present due to less than optimum bias conditions. This type driver causes the driving voltage to switch very quickly through any voltage levels where the driving current requirements drop or disappear. Although this type driver does not eliminate the need for bias in a quality amplifier, it makes the amount of bias used much less critical. In lower quality applications, such as PA work, the bias system may be removed and the amplifier run class B, generally without any noticeable effect on the quality. Amplifiers with these improvements can be expected to have distortion levels in the 0.1% range, and there should be no distortion peaks in the low power levels at the crossover point. Figure 3 is typical.

So at this point we have a pretty sophisticated amplifier with about all the gain we can handle without running into phase margin problems, or the necessity of reducing bandwidth drastically to keep the system stable. How do you improve on this circuit. A look at the oscilloscope photograph of Fig. 4 should give you a good idea. This is a photograph of the waveform at the collector of Q1 as seen



TOTAL HARMONIC DISTORTION is very low at all frequencies (curves above) and is less than 0.1% at full- and half-power levels.

DISTORTION VARIATIONS WITH POWER are illustrated by curves at left. Typically, IM distortion is below THD up to rated power output.

GAIN-PHASE PLOT (below) shows how little phase shift there is in the audio range. Phase shift is only 10° at 80 kHz.

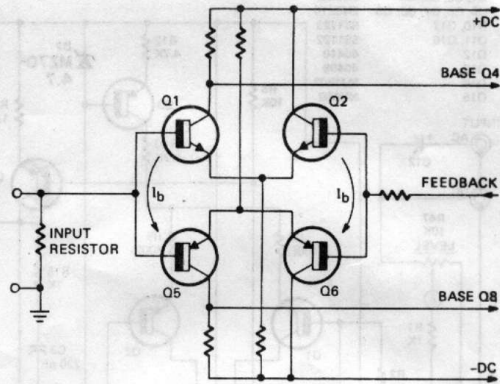
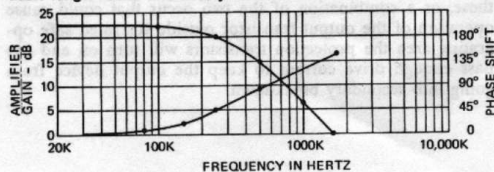

FIG. 5—COMPLEMENTARY DIFFERENTIAL INPUT STAGE. Several of its characteristics can be used to good advantage.

at base of Q3 point in the circuit of Fig. 3.

Why is this waveform so highly unsymmetrical you ask? Well the reason is quite simple. Q1 is supplying the current at this point to drive stage Q3. On positive half-cycles of the signal swing, Q3 must supply current to the driver in the upper half of the output section and also must supply the constant amount of current being soaked up by stage Q4. On negative half-cycles, however, the output requires no current from Q3 and most of the current from the current source Q4 is used to drive the lower portion of the output section. Thus on positive half-cycles, Q3 supplies output *plus* current source and on negative half-cycles current source *less* output drive. Obviously the driving signal at the base is going to be very unsymmetrical under these conditions.

So what can be done to improve on this situation? Obviously a push-pull driver would be a good solution. Then we would have two signal swings on opposite ends of the circuit that would still be unsymmetrical, but which would be of opposite polarity. Thus the distortion would be reduced as in any push-pull arrangement. There are several possible ways to drive such a system, but the most elegant is to use a complementary, cross-coupled input system. This makes the whole amplifier symmetrical and push-pull from the very input.

The complementary differential input stage also provides us with some additional advantages. With this type circuit the base current for the input pair does not all have to flow through the input resistor from ground and through the feedback resistor from the output as in a normal single ended differential pair. Referring to Fig. 5, the base current path is from Q1 into the base of Q5 provided that the base currents of the two transistors are equal. This results in *no* offset voltage across the input resistor.

Exact matching is impossible, but even if the matching is not perfect, we still have only the difference between the two base currents flowing through the input resistor to produce an offset rather than the entire base current of one transistor as in a single-ended situation. Since the differential current is so small through this resistor we can either make the resistor quite large and have a very high input impedance on the amplifier, or we can use a smaller resistor and get away with a rather large difference in base resistors without getting the considerable offset at the output of the amplifier that this would normally cause. Since input impedances over 50,000 ohms are of little value the latter course was followed on *Tiger .01*.

The only thing remaining is to choose a bias system for the output stage. The input amplifier pretty well dictates the use of a transistor for this purpose. The dual dif-

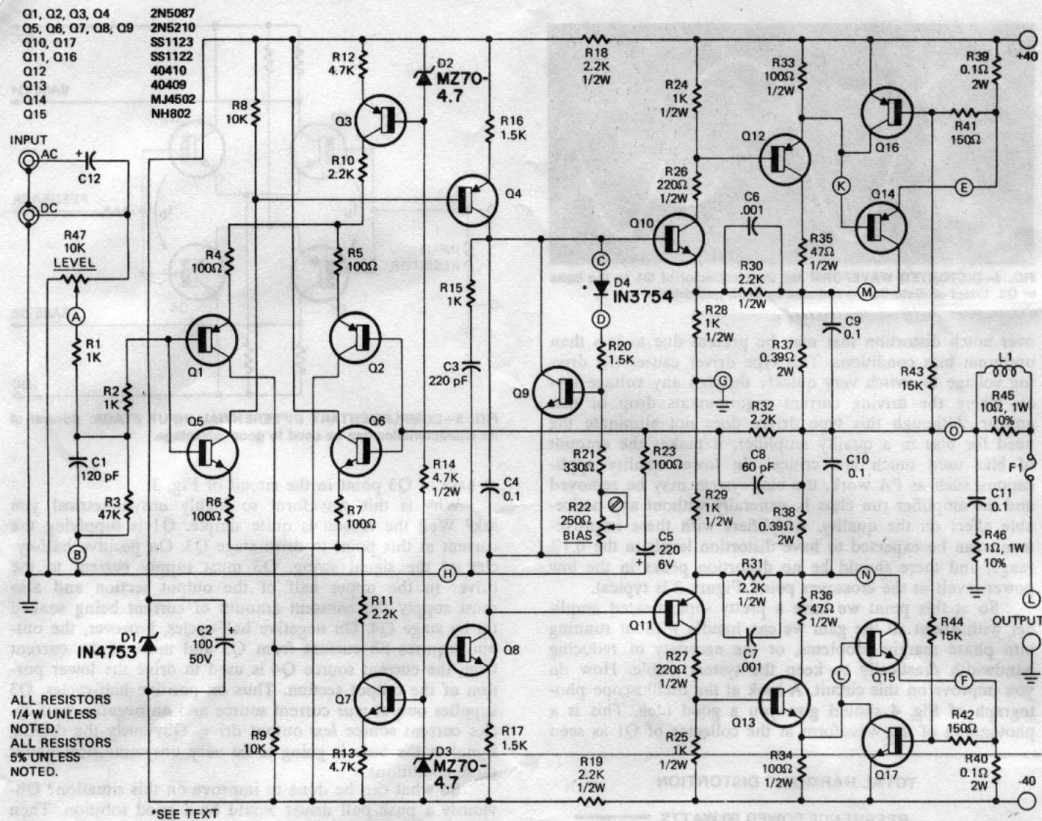

FIG. 6—COMPLETE CIRCUIT OF ONE OF THE FOUR CHANNELS. PC board patterns and complete construction details next month.

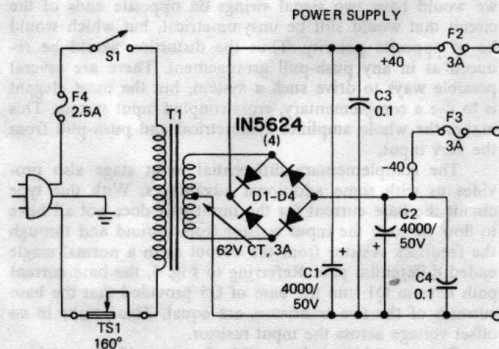

FIG. 7—POWER SUPPLY FOR ONE CHANNEL. The bridge rectifier supplies the dual-polarity voltages needed for the amplifier.

ferential input stage cannot be perfectly temperature compensated easily. As a result the idle current in the driver stage varies with temperature to some extent. If we attempted to use diodes for bias, this current variation would result in bias voltage changes. This is highly undesirable, and besides this it would take a bunch of diodes to get the 3 to 4 volts of bias that we need with this circuit (Fig. 6).

The bias voltage is set by the emitter-to-collector voltage drop across Q9. This voltage tracks quite well with the base-emitter voltage changes of Q10 and Q11 when ambient temperature changes occur. The temperature of the output transistors however is more dependent on the power output at any given time and Q9 needs some feedback information on this temperature rise if anything is to be done about stabilizing the output current with these tem-

perature changes. This information is provided by D4. The diode's forward voltage drop changes with temperature and changes the bias on Q9 to reduce the bias voltage slightly as the output transistors warm up. All this keeps the amplifier's idle current under control under all power output and ambient temperature conditions it is likely to be subjected to.

The power supply is a simple bridge rectifier system with capacitor-input filters. Due to the large amount of isolation from supply ripple and hum in the voltage amplifier stages, excellent noise figures are obtained without any complicated regulated supplies. It is doubtful that any measurable improvement would be obtained if such a supply was used. The output transistors are protected from highly reactive loads by Q16 and Q17. These transistors monitor the output transistor current and voltage drop. If either of these, or a combination of the two occur that could cause operation of the output transistor outside its rated safe operating area the protection transistors will turn on and bypass enough drive current to keep the output device from going into secondary breakdown.



BUILD POWER

Exceptionally low
quadrasonic amplifier.
story with additional

THE TIGER .01 AMPLIFIER IS THE RESULT OF MY LATEST efforts to produce a better power amplifier by reducing distortion to a new low. It is a 4-channel unit with four completely separate power amplifiers, each delivering up to 60 watts sinewave continuous power into an 8-ohm load. This story began in last month's issue.

It would be well to mention at this point that although the circuit is well supplied with limiting resistors and volt-amp protection in the output stage, it is still quite possible to "zortch" the outputs if rf signals are allowed to get into the amplifier. To provide good square-wave response out to 20,000 Hz, the bandwidth of the amplifier must be made 300 to 500,000 Hz. This is all well and good, but the output transistor efficiency becomes very poor after about 30,000 to 50,000 Hz due to storage-time effects in these devices.

As long as the input is an audio-range frequency there is no problem, but if higher frequencies are fed into the amplifier the output transistors will both be on to some extent for a considerable portion of each cycle. This is just like shorting the positive supply to the negative supply by turning on both output transistors. The effect is called "mutual conductance" and as you can imagine it causes considerable heating of the output transistors. If you want the superior transient response that you get with this kind of bandwidth, you just have to be careful about this kind of thing.

Packing and construction

Since stereo is now almost universal in home music system and the trend seems to be to four channels, the Tiger .01 package is designed to be used in anything from a single unit to four or more channels by simply adding the new channels as needed and replacing the outer trim portion of the case. The front panel is quarter-rack size, so four of these can be mounted side by side in a standard 19-inch relay rack. Each amplifier is complete with its own separate power supply, so there is no reduction in power when all channels are driven to full output and absolutely no interaction, or crosstalk. The meter to monitor output level makes it very simple to balance the complete system and gives you a good idea of what level you can operate at before you are likely to begin clipping peaks and running into excessive distortion, no matter what the speaker efficiency may be.

The majority of the parts are mounted on circuit boards to insure proper operation, and make construction simple. The rectifiers are mounted on a small circuit board that attaches directly to the lugs on the filter capacitors. The meter circuit parts are mounted on another small circuit board that attaches to the meter terminals. The amplifier parts are mounted on the main circuit board in the po-

sitions shown on the board layout. The output transistors are of course mounted to the heat sink along with sensing diode D/4.

The heat sink consists of two "Wakefield" type 641K sinks drilled so that they may be mounted back-to-back. In this way enough square inches of heat sink can be obtained to safely operate the circuit at full rated power continuously with no overheating problems. A 160° thermostat is mounted just below the heat sink just in case the amplifier is used in a cabinet, or location that does not have sufficient air circulation. This thermostat turns off the amplifier and turn on the overheat indicator lamp on the front panel if the amplifier gets too hot for further safe operation.

Construction should be no problem if the layout system shown in the photographs is used. The various parts that mount on the chassis should be installed first and the supply wired. The power supply can be tested for proper output voltage at this point. The no load dc output voltage should be in the order of ± 45 volts with normal line voltage. The meter and its circuit board and the meter illumination lamps should be installed next. The heat sinks are attached to the mounting bracket with the same screws that hold the power transistors in place. Use an insulating mica, or similar washer under the transistor cases and insulating washers under the nuts on the mounting screws. Use a thin coat of heat sink compound on each side of the washer

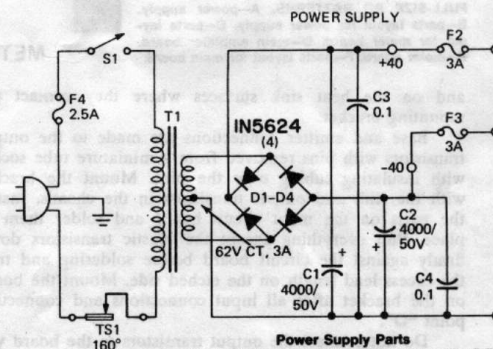

POWER SUPPLY
for one channel.
Individual supplies
contribute to the
overall performance
of the amplifier.

Power Supply Parts
T1—115V Primary—62V Secondary with C.T.,
3A rms, 5% regulation zero to full load
C1, C2—4,000 μ F, 50 Vdc
D1 thru D4—200V 3.0A 1N5624 or equal
S1—Push-push switch, 6.0A 125 Vac
TS1—160° Thermal Cutoff "Elmwood Sensors"
C3, C4—0.1- μ F 250-V film

4-CHANNEL AMPLIFIER

Low distortion is a feature of this
This month we conclude the
construction details.

by DANIEL MEYER

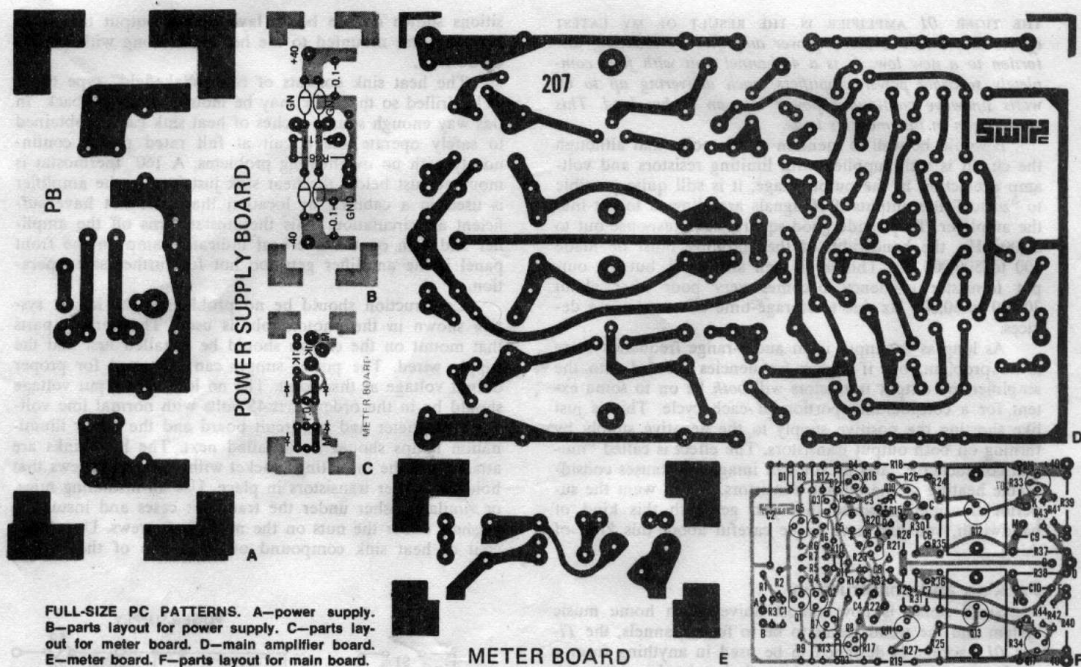
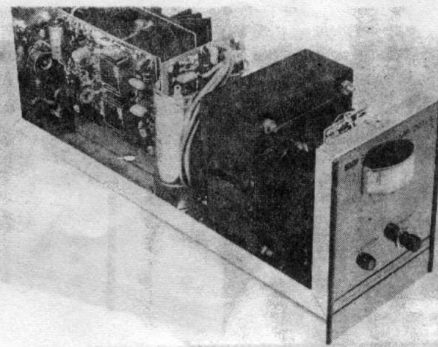

FULL-SIZE PCB PATTERNS. A—power supply. B—parts layout for power supply. C—parts layout for meter board. D—main amplifier board. E—meter board. F—parts layout for main board.

and on the heat sink surfaces where they contact the mounting bracket.

Base and emitter connections are made to the output transistors with pins removed from a miniature tube socket with insulating tubing over the pins. Mount the bracket with the sink and output transistors in the chassis. Install the parts on the main circuit board and solder them in place. Pull everything except the plastic transistors down firmly against the circuit board before soldering and trim the excess lead length on the etched side. Mount the board on the bracket after all input connections and connecting point "O".

Do not connect the output transistors to the board yet. Connect the bias diode leads to points "C" and "D" after the board is mounted to the bracket. Attach your voltmeter to the output terminals and put it on the 10 to 15-volt scale dc, whatever is close. Install the positive and negative supply fuses and the output fuse. Plug in the line cord and turn on the switch. If there is any noticeable reading on

the meter after the initial turn-on transients, or any obvious overheating of a part turn the amplifier off and start troubleshooting. If all looks normal so far you can apply an input signal and check for proper amplification.

Q12 and Q13 can provide a few hundred milliwatts of power without the output transistors which should be enough to tell if operation is correct. If it is going right so far, turn off power and connect the output transistors. Turn the bias trimmer to *maximum* resistance, connect an 8.0-ohm load and apply power again. Connect a dc voltmeter across either R37 or R38 and adjust the bias trimmer for a reading of slightly less than 20 mV. This will set the output stage for an idle current of around 50 mA, which is close to optimum.

If you have a sensitive IM analyzer with a .1% full scale range, you can adjust the bias for minimum distortion with a power output of 1 to 3 watts. Watch the meter on the front panel while testing and adjusting and if at any time the reading jumps up, or shows an output when you

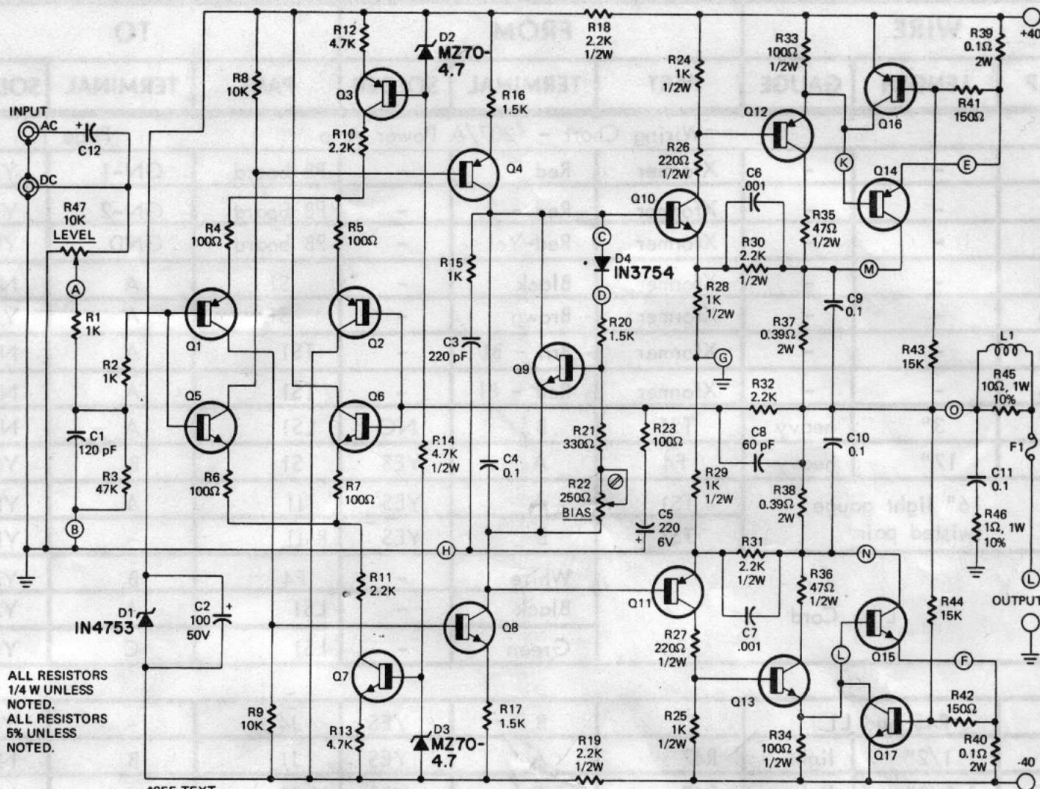

ALL RESISTORS
1/4 W UNLESS
NOTED.
ALL RESISTORS
5% UNLESS
NOTED.

*SEE TEXT

PARTS LIST—POWER AMPLIFIER

- All resistors 5%, unless noted:
 R1, R2, R15—1000 ohms 1/4 watt
 R3—47,000 ohms 1/4 watt
 R4, R5, R6, R7, R23—100 ohms 1/4 watt
 R8, R9—10,000 ohms 1/4 watt
 R10, R11, R32—2200 ohms 1/4 watt
 R12, R13—4700 ohms 1/4 watt
 R14—4700 ohms 1/2 watt
 R16, R17, R20—1500 ohms 1/4 watt
 R18, R19, R30, R31—2200 ohms 1/2 watt
 R21—330 ohms 1/4 watt
 R22—250 ohms, trimmer
 R24, R25, R28, R29—1000 ohms 1/2 watt
 R26, R27—220 ohms 1/2 watt
 R33, R34—100 ohms 1/2 watt
 R35, R36—47 ohms 1/2 watt
 R37, R38—0.39 ohms 2 watt
 R39, R40—0.1 ohms 2 watt
 R41, R42—150 ohms 1/4 watt
 R43, R44—15,000 ohms 1/4 watt
 R45—10 ohms 1 watt 10% resistor
 R46—1 ohm 1 watt 10% resistor
 R47—10,000 ohms linear potentiometer

Miscellaneous parts

- L1—Single layer of wire close wound on body of resistor R45
 F1, F2, F3—3-amp standard fuse
 F4—2.5-amp slow-blow fuse
 T1—62 Vac C.T. 3A secondary 117 Vac primary
 LM1—NE-2 neon lamp
 The following are available from: Southwest Technical Products Corp. Box 32040, 219 W. Rhapsody San Antonio, Texas 78284
 No. 207-b Circuit board for single channel of the "Tiger .01" Amplifier \$2.65 postpaid
 No. 207-C Complete Kit of parts for single channel of the "Tiger .01" Amplifier including chassis and cover, \$75.00 plus postage for 15 lbs and insurance if desired

Meter Parts

- 0-20 mA meter
 1N914 Rectifiers (4)
 .1-μF capacitor
 1000 ohms trimmer resistor
 1000 ohms 1/4-watt resistor

Capacitors

- C1—120-pF polystyrene
 C2—100-μF 50Vdc electrolytic
 C3—220-pF polystyrene
 C4, C9, C10, C11—0.1-μF mylar
 C5—220-μF 6Vdc electrolytic
 C6, C7—0.001-μF 10% discap
 C8—60-pF polystyrene
 C12—4.7-μF tantalum

Semiconductors

- D1—36-volt 1-watt Zener 1N4753 or equal
 D2, D3—4.7-volt 400-mW Zener MZ70—4.7 or equal
 D4—1N3754 compensating diode
 Q1, Q2, Q3, Q4—2N5087 silicon
 Q5, Q6, Q7, Q8, Q9—2N5210 silicon
 Q10, Q17—SS1123 silicon
 Q11, Q16—SS1122 silicon
 Q12—40410 silicon
 Q13—40409 silicon
 Q14—MJ4502 silicon
 Q15—MJ802 silicon

ELG-181 (Sylvania)

have no input; STOP quickly and check for circuit oscillation. With luck such a condition may blow the fuses, but it can also fry the outputs so don't allow such a condition to continue if it is found. The Tiger .01 should be quite stable if built and wired as shown, but any amplifier with this kind of gain, feedback and bandwidth can cause you lots of ulcers and heartburn if wire routing and grounding are not properly done.

Using your amplifier

Listening test show that builders of this amplifier will need systems in which all other components are the best

available to really appreciate the quality of this amplifier. If possible, listen to some recordings with extended high-frequency response on a wide-range electrostatic speaker system. The beautiful transient response and the smooth, effortless way in which highs are reproduced with no sign of strain, or roughness is unreal. The bass response is limited by the speaker system characteristics. The amplifier will handle material far lower than any known speaker will go. Only time will tell, but all indications are that the Tiger .01 circuit will be another of those large steps forward in the development of quality audio amplifiers. Try it, you'll like it!

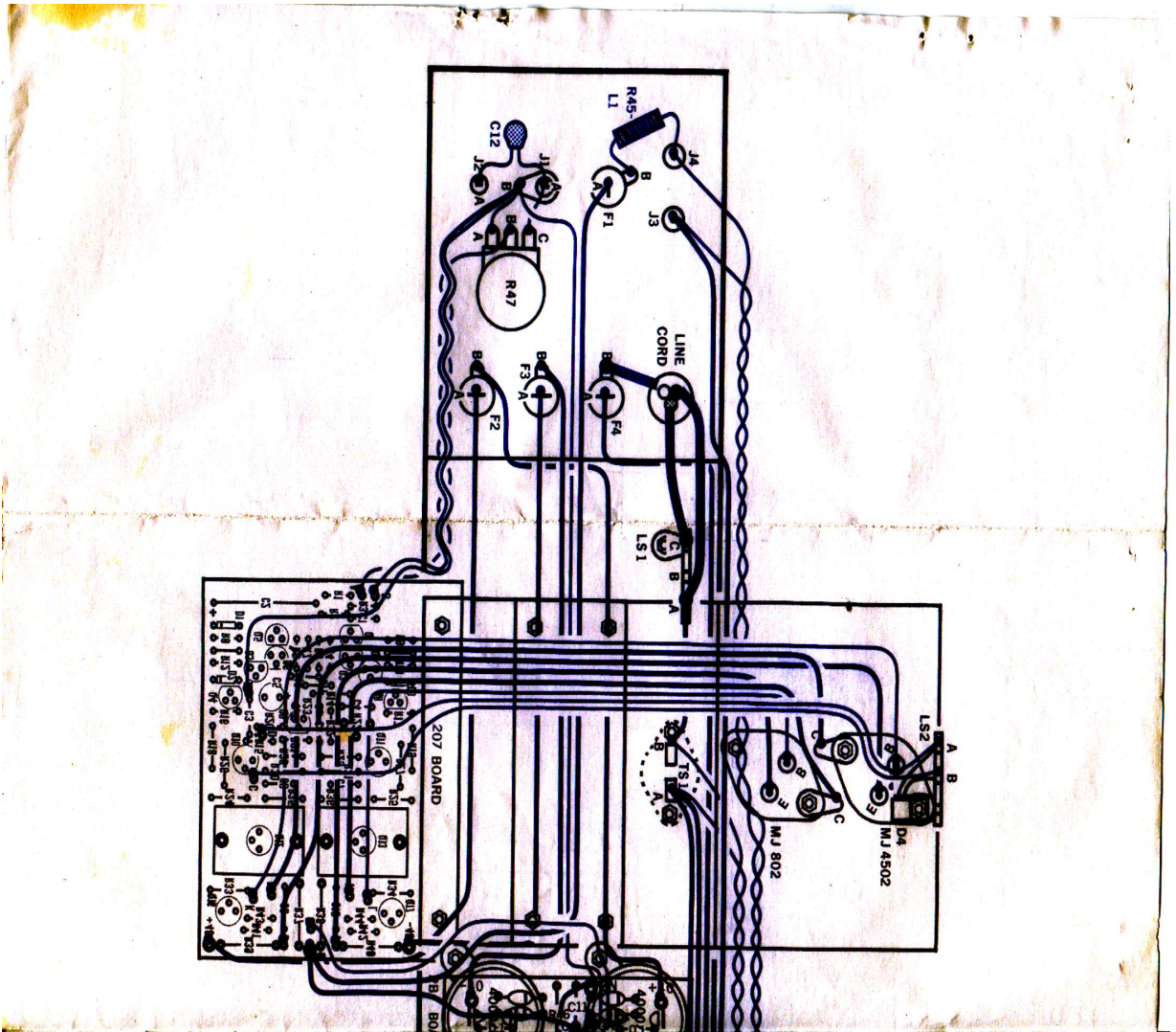

Wiring Diagram - Power Amplifier 207/A

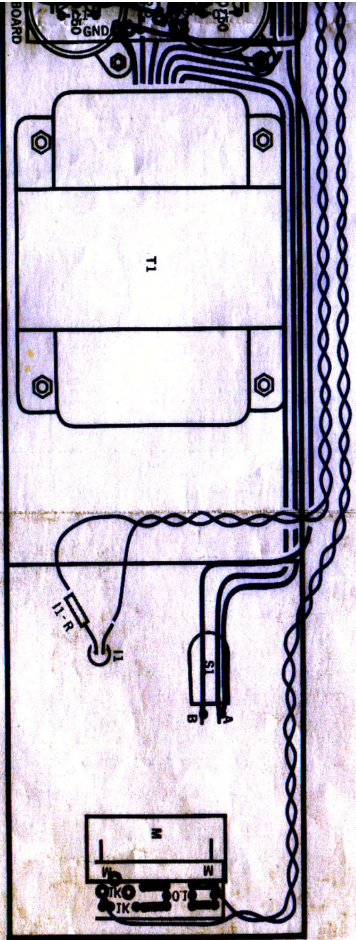

WIRE			FROM			TO		
STEP	LENGTH	GAUGE	PART	TERMINAL	SOLDER	PART	TERMINAL	SOLDER
Wiring Chart - #207/A Power Amp Page 1								
1	-	-	Xformer	Red - 1	-	PB board	GN-1	YES
2	-	-	Xformer	Red - 2	-	PB board	GN-2	YES
3	-	-	Xformer	Red-Yel	-	PB board	GND	YES
4a	-	-	Xformer	Black	-	S1	A	NO
4b	-	-	Xformer	Brown	-	S1	A	YES
5a	-	-	Xformer	Brn - Bl	-	TS1	A	NO
5b	-	-	Xformer	Red - Bl	-	TS1	A	NO
6	3"	heavy	TS1	B	NO	LS1	A	NO
7	17"	heavy	F4	A	YES	S1	B	YES
8	16" light gauge twisted pair		TS1	A	YES	I1	A	YES
			TS1	B	YES	R-11	-	YES
9	Line Cord			White	-	F4	B	YES
				Black	-	LS1	A	YES
				Green	-	LS1	C	YES
10	R45 and L1		F1	B	YES	J4	-	YES
11	1 1/2"	light	R47	A	YES	J1	B	NO
12	1 1/2"	light	R47	C	YES	J1	A	NO
13	capacitor C12		J1	A	YES	J2	A	YES
14	13"	light	J1	B	NO	PB board	GND	YES
15	13"	heavy	J3	-	YES	PB board	GND	YES
16	13"	heavy	F2	B	YES	PB board	+40	YES
17	12"	heavy	F3	B	YES	PB board	-40	YES
18	11"	heavy	207 board	+40	YES	F2	A	YES
19	6 1/2"	heavy	207 board	-40	YES	F3	A	YES
20	12"	heavy	207 board	0	NO	F1	A	YES
21	3"	heavy	207 board	0	YES	PB board	0	YES
22	4 1/2"	heavy	207 board	E	YES	MJ4502	emitter	clip
23	4 1/2"	heavy	207 board	F	YES	MJ802	emitter	clip
24	4"	light	207 board	K	YES	MJ4502	base	clip
25	4"	light	207 board	L	YES	MJ802	base	clip
26	4"	heavy	207 board	M	YES	MJ4502	case	YES
27	4"	heavy	207 board	N	YES	MJ802	case	YES
28	3 1/2"	light	207 board	G	YES	PB board	GND	YES

We think that our new push-pull cross coupled input circuit represents a major advance in amplifier design. Those of you who are familiar with amplifier circuits will recognize this as two complementary differential amplifiers, with the input and feedback points tied together. This elegant little circuit makes possible a completely push-pull amplifier.

Push-pull circuits produce distortion when they amplify just like any other circuit, but with one important difference. The upper and lower halves of a push-pull circuit produce even harmonic distortions that are equal but opposite in phase. They will therefore cancel each other out for the most part when combined at the output. Almost all transistor amplifiers use push-pull output and driver stages, but only our new #198 preamp and #207 amplifiers are push-pull throughout.

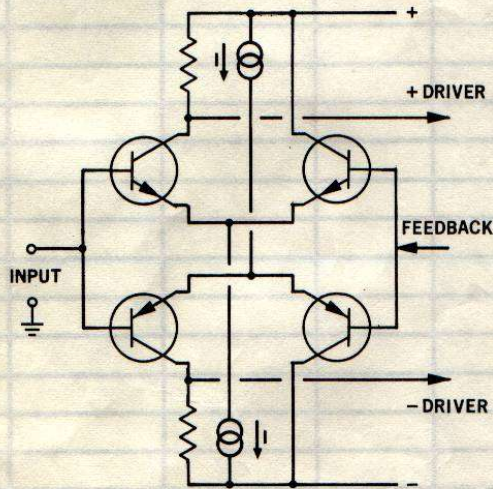

The "Tiger .01" #207/A amplifier using this new circuit is packaged in a neat little quarter rack chassis and is supplied with the perforated cover shown. This allows you to assemble a system with any number of amplifiers you might want and to later expand the system if you wish.

The #198 preamp uses the same basic circuit as the power amplifier and has similar outstanding performance. All inputs and tone control settings on the preamp are push button switch selected. The construction is primarily on two "mother boards" so wiring is kept to an absolute minimum.

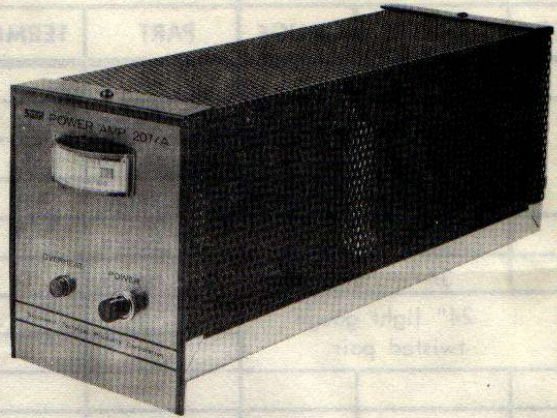

#207/A AMPLIFIER KIT...\$75.00...14 lbs

How much better is this type circuit? Considerably. The total harmonic distortion of the power amplifier is typically .02% up to full rated output of 60 Watts at 1,000 cycles. The really interesting thing though is the fact that the intermodulation distortion is less than .01% up to rated output. This circuit is therefore anywhere from around ten to a hundred times cleaner than previous designs. Now it is generally recognized that IM distortion correlates much better with listening tests than harmonic distortion. Our ears are much more sensitive to distortions that are not harmonically related to the signal. This performance is obtained with a circuit that has only 65 db open loop gain. To even approach this type performance before this required open loop gains from 80 to 120 db, 60 to 100 db of negative feedback will give you low distortion with almost any kind of circuit, but the resulting stability problems might make you wish for a better way.

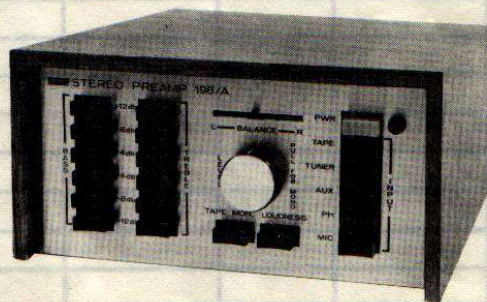

#198/A PREAMP KIT.....\$69.50.....6 lbs

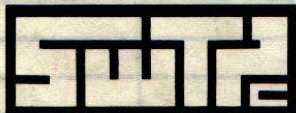

SOUTHWEST TECHNICAL PRODUCTS CORPORATION
DEPT. AE, 219 W. RHAPSODY, SAN ANTONIO, TEXAS 78216