

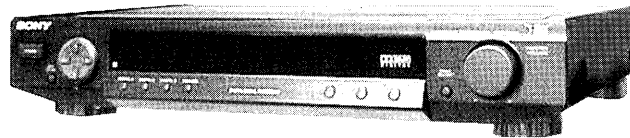

SDP-E800

SERVICE MANUAL

*US Model
Canadian Model
AEP Model
UK Model
E Model
Australian Model
Chinese Model*



This processor incorporates the Dolby Pro Logic Surround system. Manufactured under license from Dolby Laboratories Licensing Corporation. "Dolby," the double-D symbol , "AC-3" and "Pro Logic" are trademarks of Dolby Laboratories Licensing Corporation.

SPECIFICATIONS

Digital inputs	Optical: 3 Coaxial: 1 AC-3 RF: 1	Power requirements	US, Canadian 120 V AC, 60 Hz AEP, UK, German, East European, E, Singapore, Malaysia, Chinese 230 V AC, 50/60 Hz Australian 240 V AC, 50 Hz
Digital outputs	Optical: 1	Power consumption	35 W
Analog outputs	FRONT (L R), REAR (L R), CENTER, WOOFER: Output level: 1V Output impedance: 1 kilohms	Dimensions	430 x 98 x 355.5 mm (17 x 3 7/8 x 14 in)
BASS BOOST	+5 dB at 60 Hz	Mass (Approx.)	6.5 kg (14 lb 5 oz)
Video inputs	3 (ANALOG VIDEO IN, DIGITAL 1 VIDEO IN, DIGITAL 2 VIDEO IN)	Supplied accessories	Remote commander (remote) (1) Size AA (R6) batteries (2) Connecting cords (3)
Video output	1 (MONITOR OUT)		

Design and specifications are subject to change without notice.

DIGITAL SURROUND PROCESSOR

SONY®

**MODEL IDENTIFICATION
— BACK PANEL —**

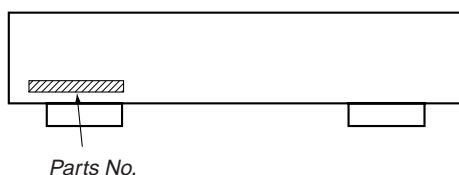

MODEL	PARTS No.
US model	4-992-696-0□
E, SP model	4-992-696-1□
AEP, UK model	4-992-696-2□
AUS model	4-992-696-3□
CND model	4-992-696-4□
CH model	4-992-696-5□

- Abbreviation
CND : Canadian model.
SP : Singapore model.
CH : Chinese model.
AUS : Australian model.
- For detailed Malaysia model refer to E model.
- For detailed German, East European model refer to AEP model.

Notes on chip component replacement

- Never reuse a disconnected chip component.
- Notice that the minus side of a tantalum capacitor may be damaged by heat.

TABLE OF CONTENTS

1. SERVICING NOTE	3
2. GENERAL	4
3. TEST MODE	13
4. DIAGRAMS	
4-1. Circuit Boards Location	14
4-2. Block Diagrams	
• DA Section	15
• DSP Section	17
• Display Section	19
• Panel Section	21
• Power Section	21
4-3. Printed Wiring Board — Main Section —	23
4-4. Schematic Diagram — D/A Section —	27
4-5. Schematic Diagram — Control Section —	31
4-6. Schematic Diagram — Dolby AC-3 Section —	35
4-7. Printed Wiring Board — Display Section —	38
4-8. Schematic Diagram — Display Section —	41
4-9. IC Block Diagrams	44
4-10. IC Pin Functions	48
5. EXPLODED VIEWS	
5-1. Case Section	60
5-2. Main Section	61
6. ELECTRICAL PARTS LIST	62

SAFETY-RELATED COMPONENT WARNING !!

COMPONENTS IDENTIFIED BY MARK \triangle OR DOTTED LINE WITH MARK \triangle ON THE SCHEMATIC DIAGRAMS AND IN THE PARTS LIST ARE CRITICAL TO SAFE OPERATION. REPLACE THESE COMPONENTS WITH SONY PARTS WHOSE PART NUMBERS APPEAR AS SHOWN IN THIS MANUAL OR IN SUPPLEMENTS PUBLISHED BY SONY.

**ATTENTION AU COMPOSANT AYANT RAPPORT
À LA SÉCURITÉ!!**

LES COMPOSANTS IDENTIFIÉS PAR UNE MARQUE \triangle SUR LES DIAGRAMMES SCHÉMATIQUES ET LA LISTE DES PIÈCES SONT CRITIQUES POUR LA SÉCURITÉ DE FONCTIONNEMENT. NE REMPLACER CES COMPOSANTS QUE PAR DES PIÈCES SONY DONT LES NUMÉROS SONT DONNÉS DANS CE MANUEL OU DANS LES SUPPLÉMENTS PUBLIÉS PAR SONY.

SECTION 1 SERVICING NOTE

SAFETY CHECK-OUT

After correcting the original service problem, perform the following safety checks before releasing the set to the customer: Check the antenna terminals, metal trim, "metallized" knobs, screws, and all other exposed metal parts for AC leakage. Check leakage as described below.

LEAKAGE

The AC leakage from any exposed metal part to earth Ground and from all exposed metal parts to any exposed metal part having a return to chassis, must not exceed 0.5 mA (500 microamperes). Leakage current can be measured by any one of three methods.

1. A commercial leakage tester, such as the Simpson 229 or RCA WT-540A. Follow the manufacturers' instructions to use these instruments.
2. A battery-operated AC milliammeter. The Data Precision 245 digital multimeter is suitable for this job.
3. Measuring the voltage drop across a resistor by means of a VOM or battery-operated AC voltmeter. The "limit" indication is 0.75 V, so analog meters must have an accurate low-voltage scale. The Simpson 250 and Sanwa SH-63Trd are examples of a passive VOM that is suitable. Nearly all battery operated digital multimeters that have a 2V AC range are suitable. (See Fig. A)

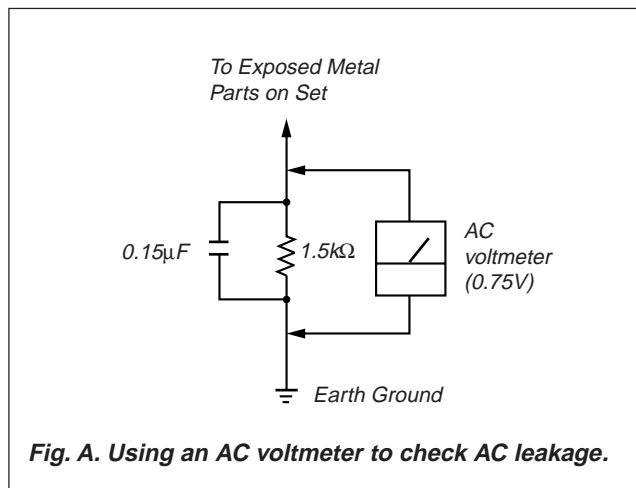

RV101 of MAIN Board

RV101 of the MAIN board requires no adjustments. Please note that it should be dixed to mechanical center position when you moved and do not know origin position.

L702 of PLL board

Do not touch the L702 on the PLL Board because it is not needed to adjust.

Connection and Test Disc

Connection of this unit to a AC-3 Dolby surround equipment will realize outstanding sound playback. Check if the respective surround channel outputs are playing back normally by the following method.

Jig :

<u>Discription</u>	<u>Part No.</u>
AC-3 TEST LD	J-2501-132-A

Connected Equipment:

AC-3 LD player
(This unit is also compatible with the digital versatile disc player (DVD). The DVD must be checked with the LD player using all the circuits of this unit.)

Connecting Method:

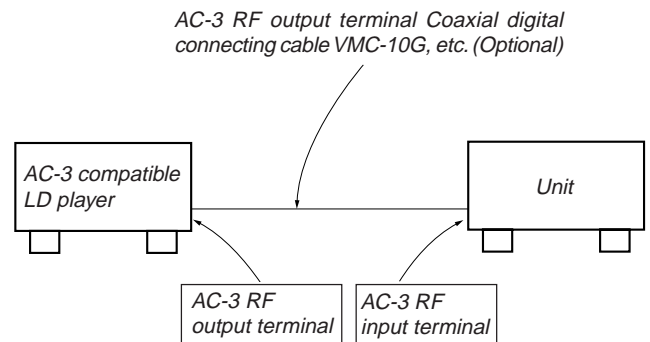

Checking Method:

Play back a test disc of the LD player, and check if the contents recorded on the disc case (printed on the disc case) are played back normally.

SECTION 2 GENERAL

This section is extracted from instruction manual.

Front Panel Descriptions

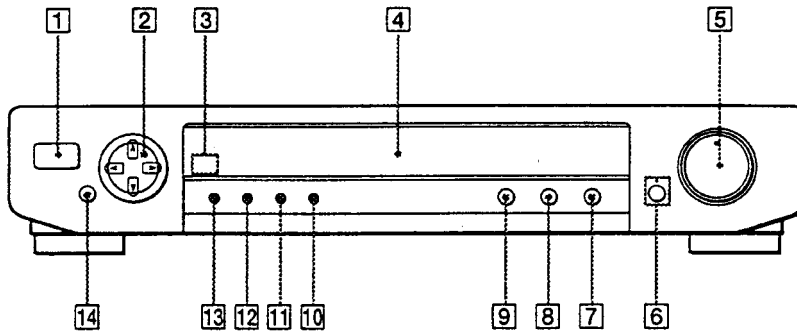

- | | | |
|------------------------------|----------------------|--------------|
| 1 POWER | 6 BASS BOOST | 11 DIGITAL 3 |
| 2 Digital processing control | 7 SOUND FIELD ON/OFF | 12 DIGITAL 2 |
| 3 Remote sensor | 8 MODE | 13 DIGITAL 1 |
| 4 Display | 9 GENRE | 14 DPC MODE |
| 5 MASTER VOLUME | 10 ANALOG | |

Rear Panel Descriptions

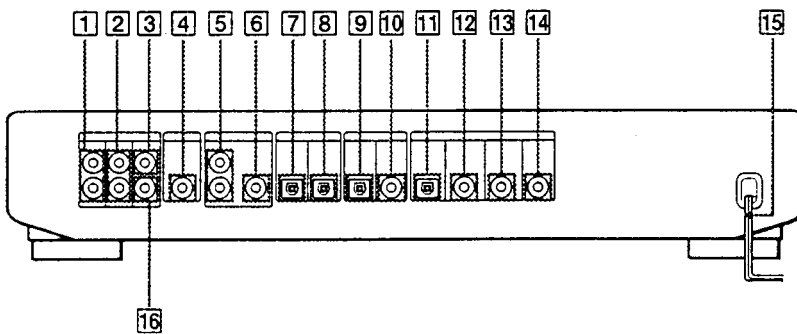

- | | | |
|---|--------------------------|------------------|
| 1 FRONT L (left) and R (right) OUTPUT | 7 DIGITAL 3: OPTICAL OUT | 15 AC power cord |
| 2 REAR L (left) and R (right) OUTPUT | 8 DIGITAL 3: OPTICAL IN | 16 WOOFER OUTPUT |
| 3 CENTER OUTPUT | 9 DIGITAL 2: OPTICAL IN | |
| 4 MONITOR OUT | 10 DIGITAL 2: VIDEO IN | |
| 5 ANALOG: audio IN L (left) and R (right) | 11 DIGITAL 1: OPTICAL IN | |
| 6 ANALOG: VIDEO IN | 12 DIGITAL 1: COAX IN | |
| | 13 DIGITAL 1: AC-3 RF | |
| | 14 DIGITAL 1: VIDEO IN | |

Unpacking

Check that you received the following items with the processor:

- Remote commander (remote) (1)
- Size AA (R6) batteries (2)
- Connecting cords (3)

Inserting batteries into the remote

Insert two size AA (R6) batteries with the + and - on the battery compartment. When using the remote, point it at the remote sensor  on the processor.

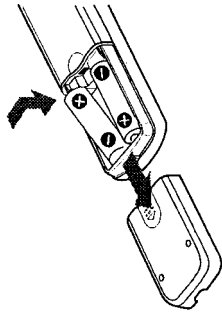

When to replace batteries

Under normal use, the batteries should last for about 6 months. When the remote no longer operates the processor, replace both batteries with new ones.

Notes

- Do not leave the remote in an extremely hot or humid place.
- Do not use a new battery with an old one.
- Do not expose the remote sensor to direct sunlight or lighting apparatuses. Doing so may cause a malfunction.
- If you don't use the remote for an extended period of time, remove the batteries to avoid possible damage from battery leakage and corrosion.

Before you get started

- Do not connect the power cord to an AC outlet or press the POWER switch before completing all connections.
- The cable connectors should be fully inserted into the jacks. Loose connection may cause hum and noise.

Source Component Hookups

The surround processor allows you to connect up to 3 digital audio (video) source components, such as a DVD player, LD player (with AC-3 RF output) and CD player (etc.). You can also connect 1 analog source component, such as a VCR.

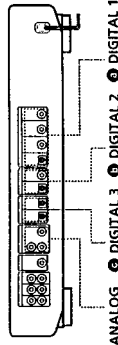

● ANALOG ● DIGITAL 1 ● DIGITAL 2 ● DIGITAL 3

What cords will I need?

- Optical digital connecting cord (not supplied)
 - Coaxial digital connecting cord (not supplied)
 - Video cable (not supplied)
 - Yellow
 - Audio/video cable (not supplied)
 - Yellow
 - White (L)
 - Red (R)
- Make sure to match the color of the plugs and the jacks:
- Yellow jacks and plugs: Video signal
 - Red jacks and plugs: Right audio channel
 - White jacks and plugs: Left audio channel

DIGITAL 3 (to a CD player or DAT/MD deck)

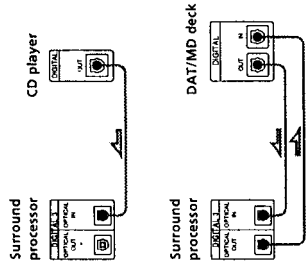

Note

This unit is only compatible with digital components using 32 kHz/44.1 kHz/48 kHz sampling frequencies. It is not compatible with 96 kHz.

DIGITAL 2 (to a VCR, etc.)

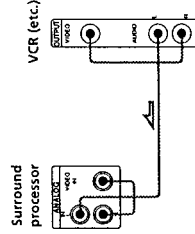

Warning regarding the playback of DAT/MD sources

When playing DAT/MD sources through this unit, do not play a DAT/MD that contains digital recordings made from a DVD player whose digital output was set to "DOLBY DIGITAL". High volume noise will be output which may damage this unit or your speakers.

DIGITAL 1 (to a LD or DVD player)

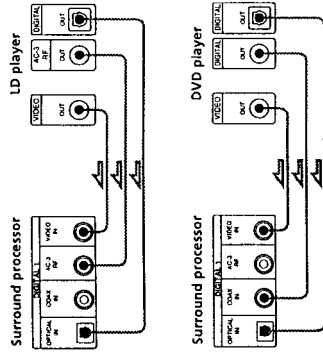

Notes for LD players

- Be sure to connect the LD player's AC-3 RF output to the surround processor's AC-3 RF input jack.
- If your LD player has an optical digital output, connect it to the DIGITAL 1 OPTICAL IN jack on this unit. This connection can be used together with the AC-3 RF connection.

DIGITAL 2 (to a DVD player or DBS tuner)

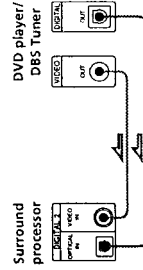

Note

If your DVD player has a coaxial digital output, we recommend connecting the DVD player's COAXIAL DIGITAL INPUT to the this unit's DIGITAL 1 COAX IN instead of making the optical connection to DIGITAL 2.

Amplifier Hookups

Connect the audio and video signals output from the surround processor to a multi-channel amplifier with 5.1 ch input and video input capability.

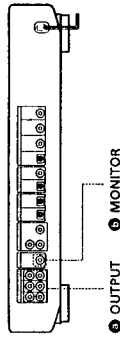

What cords will I need?

- Video cable (not supplied)
 - Audio cable (supplied)
 - White (L) / Red (R) / White (L) / Red (R)
 - Audio cable (not supplied)
 - White (or Red) / White (or Red)
- Make sure to match the color of the plugs and the jacks:
- Yellow jacks and plugs: Video signal
 - Red jacks and plugs: Right audio channel
 - White jacks and plugs: Left audio channel
 - You can use either red or white cables for the center and sub-woofer audio channels.

6 OUTPUT (to 5.1 ch audio input)

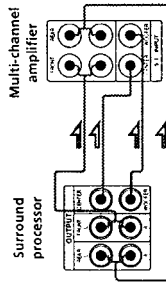

6 MONITOR (to 5.1 ch video input*)

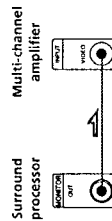

- If the 5.1 ch input does not have a corresponding video input jack, connect MONITOR to the video input jack of the function that is selected when the 5.1 input is activated. (Refer to the operating instructions supplied with your amplifier for details regarding its operation.)

Speaker Placement

Normally, to obtain the best possible surround sound all speakers should be placed the same distance from your listening position (6). This unit, however, allows you to place the center speaker closer (7), so that it lines up with the front speakers. The rear speakers can also be placed closer (8), according to the shape of your room. If you feel that this placement reduces the surround effects, you can adjust the center and rear delay parameters to obtain the effect you desire (see page 9).

Note

To take full advantage of Dolby Digital (AC-3) surround effects we recommend using high quality speakers. We also recommend using front, center, and rear speakers that are of the same size and quality.

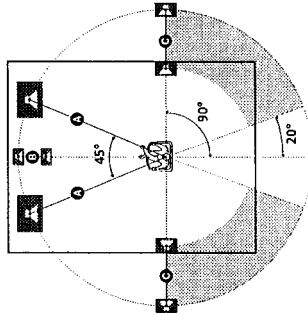

Notes

- Do not place the center or rear speakers farther away from the listening position than the front speakers.
- When mounting the rear speakers on side walls perpendicular to the listening position they should be placed 60 - 90 cm above the listening position.

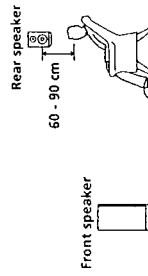

Before You Use Your Processor

If your processor has a voltage selector on the rear panel Your processor operates on either 110-120 V or 220-230 V AC. Before connecting the unit to a wall outlet, be sure to set the voltage selector on the rear of the unit to the appropriate position according to your local power supply.

Before you start using your processor, make sure that you have:

- Turned MASTER VOLUME to near the center position.

Turn on the processor and check the following indicator.

- Press MUTING on the remote if "MUTING" appears in the display.

Depending on the shape of your room (etc.), you may wish to place the rear speakers behind you instead of on the side walls. One advantage of this placement is that you can use a pair of large floor-standing speakers matching your front speakers.

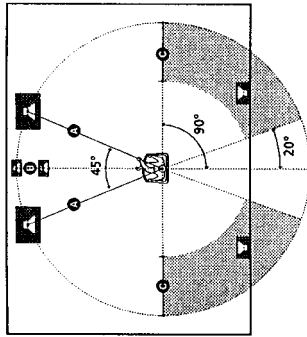

Note

If you place the rear speakers behind you, be sure to check the speaker location setting in the SP-SETUP menu when using VIRTUAL MULTI REAR and VIRTUAL REAR SHIFT sound fields (see pages 8 and 13 for details).

Speaker Set Up

To obtain the best possible surround sound, first specify the type of speakers you have connected. Then use the test tone to adjust the speaker volumes to the same level.

Specifying the speaker type

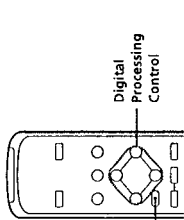
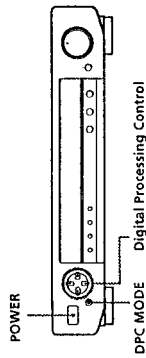

- 1 Press **POWER** on the front panel to turn on the processor.
- 2 Press **DPC MODE** repeatedly until "SP. SETUP" appears in the display
- 3 Use digital processing control buttons (\wedge / \vee) to select the parameter you want.

Front speaker

- Initial setting is: **FRONT SP. (LARGE)**
- If you connect large speakers that will effectively reproduce bass frequencies, select "LARGE".
 - If you cannot obtain sufficient surround effects when playing a Dolby Digital (AC-3) source (a source for which the DISCRETE indicator lights), select "SMALL". The bass frequencies for the front speakers will be output from the sub woofer or other "LARGE" speakers.

Center speaker

- Initial setting is: **CENTER SP. (LARGE)**
- If you connect large speakers that will effectively reproduce bass frequencies, select "LARGE".
 - If you cannot obtain sufficient surround effects when playing a Dolby Digital (AC-3) source (a source for which the DISCRETE indicator lights), select "SMALL". The bass frequencies for the center speaker will be output from the sub woofer or other "LARGE" speakers.
 - If you do not connect the center speaker, select "NO".

Rear speaker

- Initial setting is: **REAR SP. (LARGE)**
- If you connect large speakers that will effectively reproduce bass frequencies, select "LARGE".
 - If you cannot obtain sufficient surround effects when playing a Dolby Digital (AC-3) source (a source for which the DISCRETE indicator lights), select "SMALL". The bass frequencies for the rear speakers will be output from the sub woofer or other "LARGE" speakers.
 - If you do not connect rear speakers, select "NO".

Rear speaker place

- Initial setting is: **REAR SP. (SIDE)**
- This parameter lets you specify the location of your rear speakers for proper implementation of the Digital Cinema Sound VIRTUAL REAR SHIFT and VIRTUAL MULTI REAR modes. Refer to the illustration below.
- Set to **SIDE** if the location of your rear speakers corresponds to section ④.
 - Set to **BEHIND** if the location of your rear speakers corresponds to section ⑤.

This setting affects only the VIRTUAL REAR SHIFT and VIRTUAL MULTI REAR modes.
This parameter does not appear when the rear speaker parameter is set to "NO".

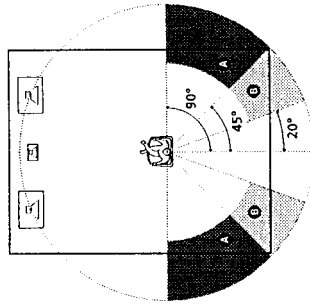

Sub woofer

- Initial setting is: **SUB WOOFER (YES)**
- If you connect a sub woofer, select "YES" to output the LFE (low frequency extension) channel from the sub woofer.
 - If you do not connect a sub woofer, select "NO". This activates the Dolby Digital (AC-3) bass redirection circuitry and outputs the LFE signals from other speakers.
 - In order to take full advantage of the Dolby Digital (AC-3) bass redirection circuitry, we recommend setting the sub woofer's cut off frequency as high as possible. (However, when using an amplifier with 5.1 ch inputs, set the sub woofer's cut off frequency to match the characteristics of the amplifier.)

- 4 Use digital processing control buttons (\ll / \gg) to adjust the level of the parameter.

Adjusting the delay time

The delay time allows you to create a more effective surround effect by adding a sense of depth to the center or rear channels. Longer delay times create a greater sense of depth.

- 1 Press **POWER** on the front panel to turn on the processor.
- 2 Press **DPC MODE** repeatedly until "OTHER SETUP" appears in the display
- 3 Use digital processing control buttons (\wedge / \vee) to select the parameter you want.

Center speaker delay

- Initial setting is: **CENTER DELAY 0ms**
- Use this parameter to add a sense of depth to the center channel.
- Center speaker delay time can be set in 1 ms steps from 0 to 5 ms.

Rear speaker delay

- Initial setting is: **REAR DELAY 5ms**
- Use this parameter to add a sense of depth to the rear channels.
- When "PKO LOGIC" is displayed, the actual delay time is 15ms longer than the time shown in the display.
- Rear speaker delay time can be set in 5 ms steps from 0 to 15 ms.

- 4 Use digital processing control buttons (\ll / \gg) to adjust the level of the parameter.

Adjusting the speaker volume

Use the remote while seated in your listening position to adjust the volume of each speaker.

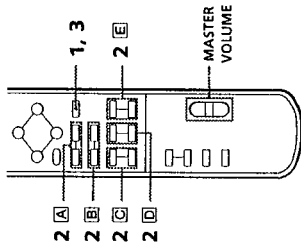

Note

This unit incorporates a new test tone with a frequency centered at 800 Hz for easier speaker volume adjustment.

- 1 Press **TEST**.
You will hear the test tone from each speaker in sequence.
- 2 From your listening position, use the remote to adjust the volume of each speaker so that the test tone can be heard at the same level from all speakers.
 - ④ Press **FRONT BAL L** or **R** to adjust the balance between the front left and right speakers (± 8 dB, 0.5 dB/step).
 - ⑤ During this adjustment, the test tone is emitted from both speakers simultaneously.
 - ⑥ Press **REAR BAL L** or **R** to adjust the balance between the rear left and right speakers (± 8 dB, 0.5 dB/step).
 - ⑦ During this adjustment, the test tone is emitted from both speakers simultaneously.
 - ⑧ Press **CENTER +** or **-** to adjust the level of center speaker (+10 to -20 dB, 0.5 dB/step).
 - ⑨ During this adjustment, the test tone is emitted from the center speaker.
 - ⑩ Press **REAR +** or **-** to adjust the level of rear speakers (+10 to -20 dB, 0.5 dB/step).
 - ⑪ During this adjustment, the test tone is emitted from both speakers simultaneously.
 - ⑫ Press **SUB WOOFER +** or **-** to adjust the level of the sub woofer (+10 to -20 dB, 0.5 dB/step).
 - ⑬ During this adjustment, the test tone is emitted from the sub woofer.
- 3 Press **TEST** to turn off the test tone.

(continued)

-  **To adjust the volume of all the speakers at one time.** Use MASTER VOLUME on the processor, remote, or your multichannel processor.
- When using an amplifier with 5.1 ch inputs, set this unit's MASTER VOLUME to near the center position and adjust the amplifier's volume control.

Notes

- The test tone will not be emitted if the sound field is set to VIRTUAL ENHANCED A/B, ACOUSTIC or KARAOKE.
- The front balance, rear balance, center level, rear level, and sub woofer level are shown in the display during adjustment.
- Although these adjustments can also be made with the LEVEL ADJUST menu using the digital processing control buttons on the front panel, we recommend you follow the procedure described above and adjust the speaker levels from your listening position using the remote control.

Selecting a Component

To listen to or watch a connected component, first select the function on the processor or with the remote. Before you begin, make sure you have:

- Connected all components securely and correctly as indicated on pages 4 to 7.
- Turned MASTER VOLUME to near the center position (when using an amplifier with 5.1 ch inputs).
- Turned MASTER VOLUME to the leftmost position (when using separate amplifiers for each speaker).

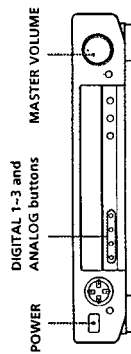

- Press POWER to turn on the processor.
- Select the component you want to use:

To listen or watch	Press
An LD or DVD player, connected to the DIGITAL 1 input jacks.*1	DIGITAL 1 repeatedly**2
Digital components connected to the DIGITAL 2 or 3 input jacks.	DIGITAL 2 or 3
An analog component connected to the ANALOG input jacks.	ANALOG

*1 This unit's digital inputs detect Dolby Digital (AC-3) or PCM signals automatically. (The AC-3 RF input terminal for use with LD players is for Dolby Digital (AC-3) signals only.)

**2 Press repeatedly to choose the appropriate input jack for the DIGITAL 1 audio signals (AC-3 RF), (OPTICAL) or (COAXIAL).

- Select the 5.1 ch input on your multi-channel amplifier and make sure the amplifier's video selector is set appropriately (see page 6).

EXAMPLE: Turn FUNCTION to select "LD", then press 5.1 INPUT (for Sony TA-V48ES). At this time, set the MASTER VOLUME control on your amplifier to "0".

- Turn on the source component, the LD player for example, and start playback.

- Use the MASTER VOLUME on your multichannel amplifier to adjust the volume.

To	Do This
Mute the sound	Press MUTING on the remote. Press again to restore the sound.
Reinforce the bass	Press BASS BOOST to turn on the BASS BOOST indicator.
Turn off the display	Press DISPLAY on the remote.
Adjust the level of the sub woofer	Press SUB WOOFER +/- on the remote.

Using the remote

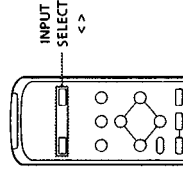

- Press POWER on the front panel to turn on the processor.
- Press INPUT SELECT < or > repeatedly to display the input for the component you want to use. The inputs change as follows each time you press INPUT SELECT.

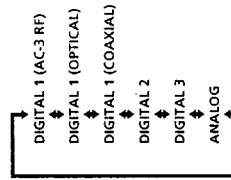

Selecting a Sound Field

You can select a sound field according to the type of source you are playing.

When playing program sources recorded in the Dolby Digital (AC-3) format, you can enjoy surround sound simply by selecting "DOLBY".

This unit also incorporates several pre-programmed "Digital Cinema Sound" modes. Select from these surround modes according to your preference to enjoy powerful sound effects from a wide variety of program sources.

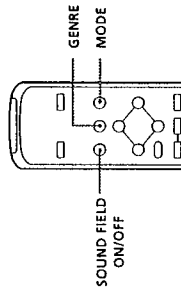
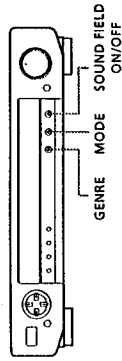

- 1 Press **GENRE** repeatedly to display the sound field genre (The previously selected mode also appears).
- 2 Press **MODE** repeatedly to display the sound field mode.

For the list of sound fields, see page 13.

To turn off the sound fields (2 channel stereo playback) Press **SOUND FIELD ON/OFF**. At this time, the input signals are automatically downmixed to 2 ch. (L, R) stereo signals.

You can find Dolby Surround-encoded software by looking at the packaging. Use discs with the logo. In order to enjoy Dolby Digital (AC-3) playback you must use discs bearing this logo.

Notes on the output of Dolby Digital (AC-3) source signals
When Dolby Digital (AC-3) encoded sources are played back through this unit, the output method changes automatically according to the information recorded on the source and the settings of this unit.

- When playing a source encoded with discrete information
if the "DOLBY" sound field is set to ON: The DISCRETE indicator lights up and the number of channels recorded in the source are decoded and output directly without adjustment.
if a sound field (other than "ACOUSTIC") is set to ON: The DISCRETE indicator lights up and the number of channels recorded in the source are decoded. The effects provided by each sound field are then added to each channel before the sound is output.
if the "ACOUSTIC" soundfield is selected or the sound field is set to OFF: The source signal is downmixed to 2 ch (Left and Right) stereo before output. When "ACOUSTIC" is selected equalizer (EQ) adjustments can be performed.

- When playing a source encoded with Dolby Pro Logic information

if the "DOLBY" sound field is set to ON: "PRO LOGIC" appears in the display, the sound is decoded using Pro Logic formula and output.
if a sound field (other than "ACOUSTIC") is set to ON: The effects provided by each sound field are added to each channel before the sound is output.
When the sound field genre is MOVIE (except for MONO MOVIE) or 3D the sound is decoded using the Pro Logic formula and "PRO LOGIC" appears in the display.

if the "ACOUSTIC" soundfield is selected or the sound field is set to OFF: The source signal is downmixed to 2 ch (Left and Right) stereo before output. When "ACOUSTIC" is selected equalizer (EQ) adjustments can be performed.

Note

When playing back normal PCM or analog sources in surround sound "PRO LOGIC" is not shown in the display.

Genre	Mode	Surround effect
DOLBY	NORMAL	Decodes programs processed with Dolby Surround.
	ENHANCED	Additional output from rear speakers when decoding Dolby Surround programs.
	CINEMA STUDIO A	Reproduces the sound characteristics of the Sony Pictures Entertainment "Cary Grant Theater" cinema production studio.
MOVIE	CINEMA STUDIO B	Reproduces the sound characteristics of the Sony Pictures Entertainment "Kim Novak Theater" cinema production studio.
	CINEMA STUDIO C	Reproduces the sound characteristics of the Sony Pictures Entertainment scoring stage.
	SMALL THEATER	
	MEDIUM THEATER	Adds acoustic reflections of a theaters to decoded Dolby Surround signals.
	LARGE THEATER	
	NIGHT THEATER	Provides surround effects for listening at low volume levels.
	MONO MOVIE	Creates a theater-like environment from movies with 2-channel monaural soundtracks.
3D	VIRTUAL ENHANCED A	Uses 3D sound imaging to create virtual rear speakers from the sound of the front speakers without using actual rear speakers. The virtual speakers are reproduced as shown in III.
	VIRTUAL ENHANCED B	Uses 3D sound imaging to create virtual rear speakers from the sound of the front speakers without using actual rear speakers. The virtual speakers are reproduced as shown in III.
	VIRTUAL REAR SHIFT	Uses 3D sound imaging to shift the sound of the rear speakers away from the actual speaker position (III.). The shift position differs according to the setting of the rear speaker position (see page 8).
	VIRTUAL MULTI REAR	Uses 3D sound imaging to create an array of virtual rear speakers from a single pair of actual rear speakers (III.). The position of the virtual rear speakers differs according to the setting of the rear speaker position (see page 8).
MUSIC	SMALL HALL	Reproduces the acoustics of a rectangular concert hall. Ideal for soft acoustic sounds.
	LARGE HALL	
	SMALL OPERA HOUSE	Reproduces the acoustics of an opera house. Ideal for musicals and operas.
	LARGE OPERA HOUSE	
	SMALL JAZZ CLUB	Reproduces the acoustics of a jazz club.
	LARGE JAZZ CLUB	
	CHURCH	Reproduces the acoustics of a church.
	LIVE HOUSE	Reproduces the acoustics of a rock and roll club.
	ACOUSTIC	Reproduces normal 2-channel stereo with equalization (EQ).
	KARAOKE	Reduces the vocal tracks of normal 2-channel stereo music sources.
SPORTS	ARENA	Reproduces the feeling of a large concert arena. Great for rock and roll.
	STADIUM	Reproduces the feeling of a large open-air stadium. Great for electric sounds.
GAME	CAME	Obtains maximum audio impact from video game software.

III. VIRTUAL ENHANCED (SURROUND) A

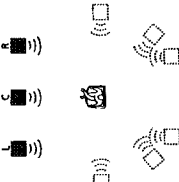

III. VIRTUAL ENHANCED (SURROUND) B

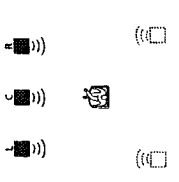

III. VIRTUAL REAR SHIFT

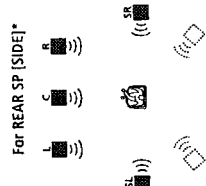

III. VIRTUAL MULTI REAR

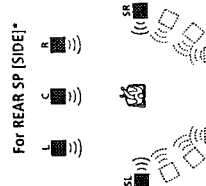

* See page 8 for details on how to set the rear speaker position.

L : Front speaker (left)
 R : Front speaker (right)
 C : Center speaker
 SL : Rear speaker (left)
 SR : Rear speaker (right)
 : Virtual speaker

Customizing the Sound Fields

Each sound field is composed of equalizer parameters (bass/treble) and surround sound parameters — variables of sound that create the sound image. You can customize the sound fields by adjusting some of the sound parameters (equalizer and/or surround sound parameters) to suit your listening situation.

Once you customize the sound fields, they are stored in memory unless the processor is unplugged for about 1 week. To change a customized sound field, make new adjustments to the respective sound field.

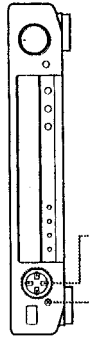

DPC MODE Digital processing control

1 Start playing a component, then select the sound field you want to adjust.

2 Press DFC MODE repeatedly to display on of the following menus:

- SP. SETUP
- LEVEL ADJUST
- SURROUND
- EQUALIZER
- OTHER SETUP

3 Use digital processing control buttons (▲/▼) to select the parameter you want.

4 Use digital processing control buttons (</>) to adjust the parameter.

Compressing the dynamic range (except for ACOUSTIC)

When inputting a Dolby Digital (AC-3) signal, you can compress the dynamic range of the sound track by using the dynamic range compression ratio (D. RANGE COM(D) parameter in the surround menu. This may be useful when you want to watch movies at low volumes late at night. See page 16 for details on the dynamic range-compression parameter.

Note

Certain parameters may not be available for adjustment depending on the current settings and menu modes.

Adjustable sound parameters		Surround sound parameters						
Equalizer parameter								
Genre	Mode	EQ	C.LEV.* (R.BAL.*)	R.LEV.* (R.BAL.*)	LFE MIX (F-R/L-R)	WALL (F-R/L-R)	REVERB	EFFECT
DOLBY	NORMAL	●	●	●	●	●	●	●
	ENHANCED	●	●	●	●	●	●	●
MOVIE	CINEMA STUDIO A	●	●	●	●	●	●	●
	CINEMA STUDIO B	●	●	●	●	●	●	●
	CINEMA STUDIO C	●	●	●	●	●	●	●
3D	SMALL THEATER	●	●	●	●	●	●	●
	MEDIUM THEATER	●	●	●	●	●	●	●
	LARGE THEATER	●	●	●	●	●	●	●
	NIGHT THEATER	●	●	●	●	●	●	●
MUSIC	MONO MOVIE	●	●	●	●	●	●	●
	VIRTUAL ENHANCED A	●	●	●	●	●	●	●
	VIRTUAL ENHANCED B	●	●	●	●	●	●	●
	VIRTUAL REAR SHIFT	●	●	●	●	●	●	●
	VIRTUAL MULTI REAR	●	●	●	●	●	●	●
	SMALL HALL	●	●	●	●	●	●	●
	LARGE HALL	●	●	●	●	●	●	●
	SMALL OPERA HOUSE	●	●	●	●	●	●	●
	LARGE OPERA HOUSE	●	●	●	●	●	●	●
	SMALL JAZZ CLUB	●	●	●	●	●	●	●
SPORTS	LARGE JAZZ CLUB	●	●	●	●	●	●	●
	CHURCH	●	●	●	●	●	●	●
	LIVE HOUSE	●	●	●	●	●	●	●
	ACOUSTIC	●	●	●	●	●	●	●
GAME	KARAOKE	●	●	●	●	●	●	●
	ARENA	●	●	●	●	●	●	●
GAME	STADIUM	●	●	●	●	●	●	●
	GAME	●	●	●	●	●	●	●

* These settings are not stored separately for each sound mode. They effects all of the sound modes simultaneously.

Notes

- All of the previous surround modes can be used with Dolby Digital (AC-3) sound sources (except for ACOUSTIC).
- C.LEV. = Center Level, R.LEV. (R.BAL.) = Rear Level (Rear Balance), W.LEV. = Woofer Level, LFE MIX (D.COMP) = Low Frequency Effect Mix (Dynamic Compression), WALL = Wall type, SEAT (F-R/L-R) = Seat (Front-Rear/Left-Right), REVERB = Reverberation, EFFECT = Effect level

SURROUND menu

Surround effect level

Initial setting is : **EFFECT** [-----]
This parameter can be adjusted directly using **EFFECT +/-** on the remote. It lets you adjust the "presence" of the current digital cinema sound surround effect.

- The effect level can be adjusted from 0% to 100% (150%).
- In the KARAOKE mode, use the effect level to adjust the amount of vocal cancellation. Greater effect levels produce greater reduction of the vocals.

Wall Type

Initial setting is : **WALL** S-----H
It lets you adjust the "brightness" of the of the current digital cinema sound surround effect.
When sound is reflected off soft material, such as a curtain, the high frequency elements are reduced. A hard wall is highly reflective and does not significantly affect the frequency response of the reflected sound.

The WALL parameter lets you control the level of the high frequencies to alter the sonic character of your listening environment by simulating a softer (S), or harder (H) wall. The midpoint designates a neutral wall (made of wood).

Front to rear seat position

Initial setting is : **SEAT** F-----R
It lets you control the balance of direct and reflected sound to simulate your listening position. "F" signifies the front of the room and "R" signifies the rear. The midpoint designates the center.

Left to right seat position

Initial setting is : **SEAT** L-----R
It lets you control the balance of direct and reflected sound to simulate your listening position. "L" signifies the left side of the room and "R" signifies the right side. The midpoint designates the center.

Reverberation time

Initial setting is : **REVERB** S-----L
It lets you adjust the amount of reverberation present in the current digital cinema sound surround effect.
This parameter adjusts the length of time required for the reverberation (echoes) generated from a given sound to attenuate -60 dB.
You can choose shorter (S) or longer (L) reverberation times.

Low Frequency Extension (LFE) mix level (DISCRETE only)

Initial setting is : **LFE MIX** 0dB
This parameter lets you attenuate the level of the LFE (Low Frequency Extension) channel output from the sub woofer without affecting the level of the bass frequencies sent to the sub woofer from the front, center or rear channels via the bass redirection circuitry.

- The level can be adjusted in 0.5 dB steps from -20.0 dB to 0 dB (line level). 0 dB outputs the full LFE signal at the mix level determined by the recording engineer.
- Selecting MUTE mutes the sound of the LFE channel from the sub woofer. However, the low frequency sounds of the front, center, or rear speakers are output from the sub woofer according to the settings made for each speaker in the speaker setup (page 8).

Dynamic range compression ratio

Initial setting is : **D RANGE COMP** OFF
Lets you compress the dynamic range of the sound track. This may be useful when you want to watch movies at low volumes late at night.

- OFF reproduces the sound track with no compression.
- STD reproduces the sound track with the full dynamic range as intended by the recording engineer.
- 0.1 - 0.9 allow you to compress the dynamic range in small steps to achieve the sound you desire.
- MAX provides a dramatic compression of the dynamic range.

EQUALIZER menu

The initial settings are different for each mode.

Front speaker bass adjustment

Level : **F: BASS** 0 dB
Frequency : **F: BASS** 250Hz
Use the +/- knob to adjust the level, then turn the MENU knob to move select the frequency (Hz) and use the +/- knob to adjust the frequency. Repeat until you achieve the sound you desire.

- The level can be adjusted ± 10 dB in 0.5 dB steps.

Front speaker treble adjustment

Level : **F: TREBLE** 0 dB
Frequency : **F: TREBLE** 2.5kHz
Adjust as described in "Front speaker bass adjustment".

- The level can be adjusted ± 10 dB in 0.5 dB steps.

Center speaker bass adjustment

Level : **C: BASS** 0 dB
Frequency : **C: BASS** 250Hz
Adjust as described in "Front speaker bass adjustment".

- The level can be adjusted ± 10 dB in 0.5 dB steps.

Center speaker treble adjustment

Level : **C: TREBLE** 0 dB
Frequency : **C: TREBLE** 2.5kHz
Adjust as described in "Front speaker bass adjustment".

- The level can be adjusted ± 10 dB in 0.5 dB steps.

Rear speaker bass adjustment

Level : **R: BASS** 0 dB
Frequency : **R: BASS** 250Hz
Adjust as described in "Front speaker bass adjustment".

- The level can be adjusted ± 10 dB in 0.5 dB steps.

Rear speaker treble adjustment

Level : **R: TREBLE** 0 dB
Frequency : **R: TREBLE** 2.5kHz
Adjust as described in "Front speaker bass adjustment".

- The level can be adjusted ± 10 dB in 0.5 dB steps.

OTHER SETUP menu

Center speaker delay

Initial setting is : **CENTER** 0 dB
See "Adjusting the delay time" on page 9 for details.

Rear speaker delay

Initial setting is : **REAR** 5 dB
See "Adjusting the delay time" on page 9 for details.

Dimmer level

This setting lets you select the the brightness of the display on the front panel.

- You can select between four different settings.

SP. SETUP menu

The speaker setup menu contains parameters that allow you to set the type and size of the speakers in your system. This information is essential for production of realistic surround sound. For details about the settings available in this menu see "Speaker Set Up" on page 8 for details).

Front speaker

Initial setting is : **FRONT SP.** (LARGE)

Center speaker

Initial setting is : **CENTER SP.** (LARGE)

Rear speaker

Initial setting is : **REAR SP.** (LARGE)

Rear speaker place

Initial setting is : **REAR SP.** (SIDE)

Sub woofer

Initial setting is : **SUB WOOFER** (YES)

LEVEL ADJUST menu

The LEVEL ADJUST menu contains speaker level adjustment parameters that allow you to balance output level to each speaker.

⚙️ These settings can also be adjusted directly using remote. See "Adjusting the speaker volume" (page 9).

Front speaker balance

Initial setting is : **FRONT** L-----R
Lets you adjust the balance between the front left and right speakers.

Rear speaker balance

Initial setting is : **REAR** L-----R
Lets you adjust the balance between the rear left and right speakers.

Rear speaker level

Initial setting is : **REAR** 0 dB
Lets you adjust level of the rear (left and right) speakers.

Center speaker level

Initial setting is : **CENTER** 0 dB
Lets you adjust the level of the center speaker.

Sub woofer level

Initial setting is : **SUB WOOFER** 0 dB
Lets you adjust the level of the sub woofer.

Digital Recording

This processor makes it easy to make digital recordings from the components connected to the processor. You don't have to connect playback and recording components directly.

Before you begin, make sure you've connected all components properly.

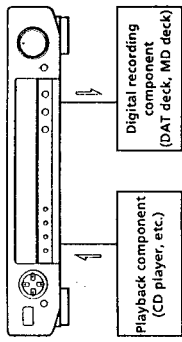

Signal flow

EXAMPLE: Recording a CD using a DAT deck. See your DAT or CD player's instruction manual if you need help.

- 1 Press **DIGITAL 2** (if a CD player is connected to the **DIGITAL 2 INPUT**) to select the CD player.
- 2 Insert a blank digital audio tape into the DAT for recording.
- 3 Start recording on the DAT and then start playing the CD you want to record.

Notes

- You cannot record the digital signal from a Dolby Digital (AC-3) program source.
- You cannot record the video signal from a connected source component.

SECTION 3 TEST MODE

[Self-Diagnosis and Test Mode]

This unit is provided with a “self-diagnosis and self-recovery function” which detects DSP errors and automatically recovers the unit, and a test mode for performing operation checks during repairs.

1. Main Functions

1. DSP Error Messages
2. Various operation check mode
3. Initialization

2. Entering the Test Mode

While pressing the [DIGITAL 2] button and [ANALOG] button simultaneously in the power OFF state, press the [POWER] button.

1. DSP Error Messages

When errors occur in the DSP, they are displayed on the fluorescent display tube.

(Refer to Table 1 for the error messages displayed.)

Table-1:

Cause of error (Display)	Possible cause
① Failed in initial booting (BOOT ERROR)	Mostly due to faulty connection (soldering) between DSP and microprocessor
② DSP does not operate (RPLY ERROR)	Faulty DSP clock (X102 and onwards), faulty DSP part, etc.
③ Communication port malfunction (HREQ ERROR)	Overrunning of DSP due to heat, microprocessor bugging, or IC701 (PLL board PLL) is faulty
④ No reply from DSP (VRFY ERROR)	Faulty DSP part, or faulty microprocessor part, etc.

2. Operation Check Mode

- During the operation check mode, functions can be set by pressing the corresponding button. (See Table-2.)
- When a button other than those displayed in Table 2 is pressed, press the [POWER] button to exit the check mode.

Table-2:

Button	Fluorescent Display Tube Display	Function
DIGITAL1	OPT-1 (L-FL, R-FR)	Like normal operations, Lch is output to Lch and Rch to Rch.
DIGITAL2	OPT-2 (L-SL, R-SR)	Outputs the Lch DIGITAL-2 input signal to the REAR Lch and the Rch to the REAR Rch.
DIGITAL3	OPT-3 (L-C, R-SW)	Outputs the Lch DIGITAL-3 input signal to the CENTER and the Rch only to the WOOFER.
ANALOG	COAX (L, R-ALL)	Outputs the Lch DIGITAL 1 COAXIAL input signal to the FRONT Lch, REAR Lch, CENTER, and the Rch to the FRONT Rch, REAR Rch, and CENTER.

3. Initialization

After executing the test mode, be sure to perform initialization.

When the [POWER] button is pressed while pressing the [DIGITAL 1] button and [DIGITAL 3] button, “All Clear!” is displayed on the fluorescent display tube and all internal settings are initialized.

[Fluorescent Display Tube All Lit]

With the power OFF, while pressing the [DIGITAL 3] button and [✓] button together, press the [POWER] button to turn ON the power. The fluorescent display tube all lit mode will be set.

Button name	Fluorescent display tube state
DIGITAL 1	All lit
DIGITAL 2	Partial lighting 1
DIGITAL 3	Partial lighting 2
ANALOG	OFF

When the other buttons are pressed, press the [POWER] button to exit the mode.

Partial lighting 1



Partial lighting 2

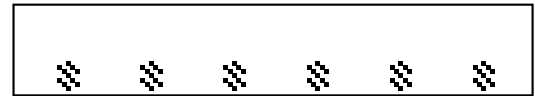

[Key Check Mode]

When the [POWER] button is pressed while pressing the [DIGITAL 1] button and [ANALOG] button, “KEY CHECK:12 KEYS” is displayed on the fluorescent display tube and the key check mode is set.

When the [POWER] button is pressed during this mode, the number at “12 KEYS” is counted down. When all other buttons are pressed, the number stops at “00 KEYS” (Note: The number is not counted down when buttons already pressed once are pressed again.)

To exit the mode, press the [POWER] button and turn OFF the power.

SECTION 4 DIAGRAMS

4-1. CIRCUIT BOARDS LOCATION

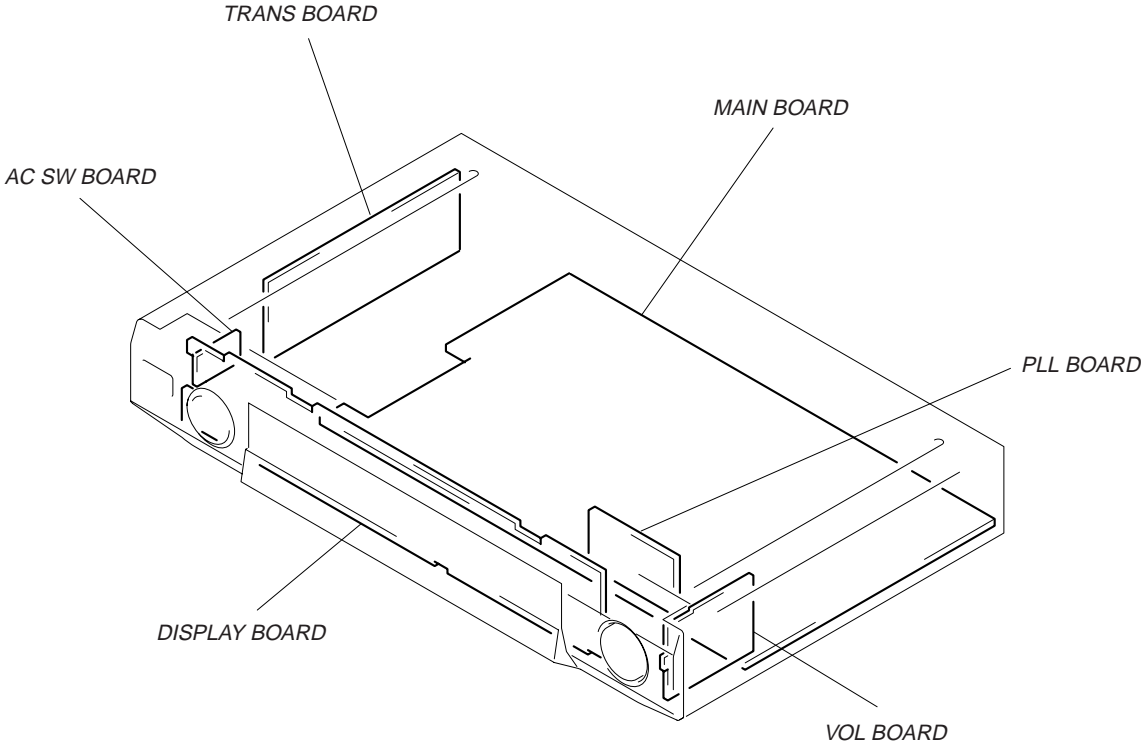

4-2. BLOCK DIAGRAMS
— DA SECTION —

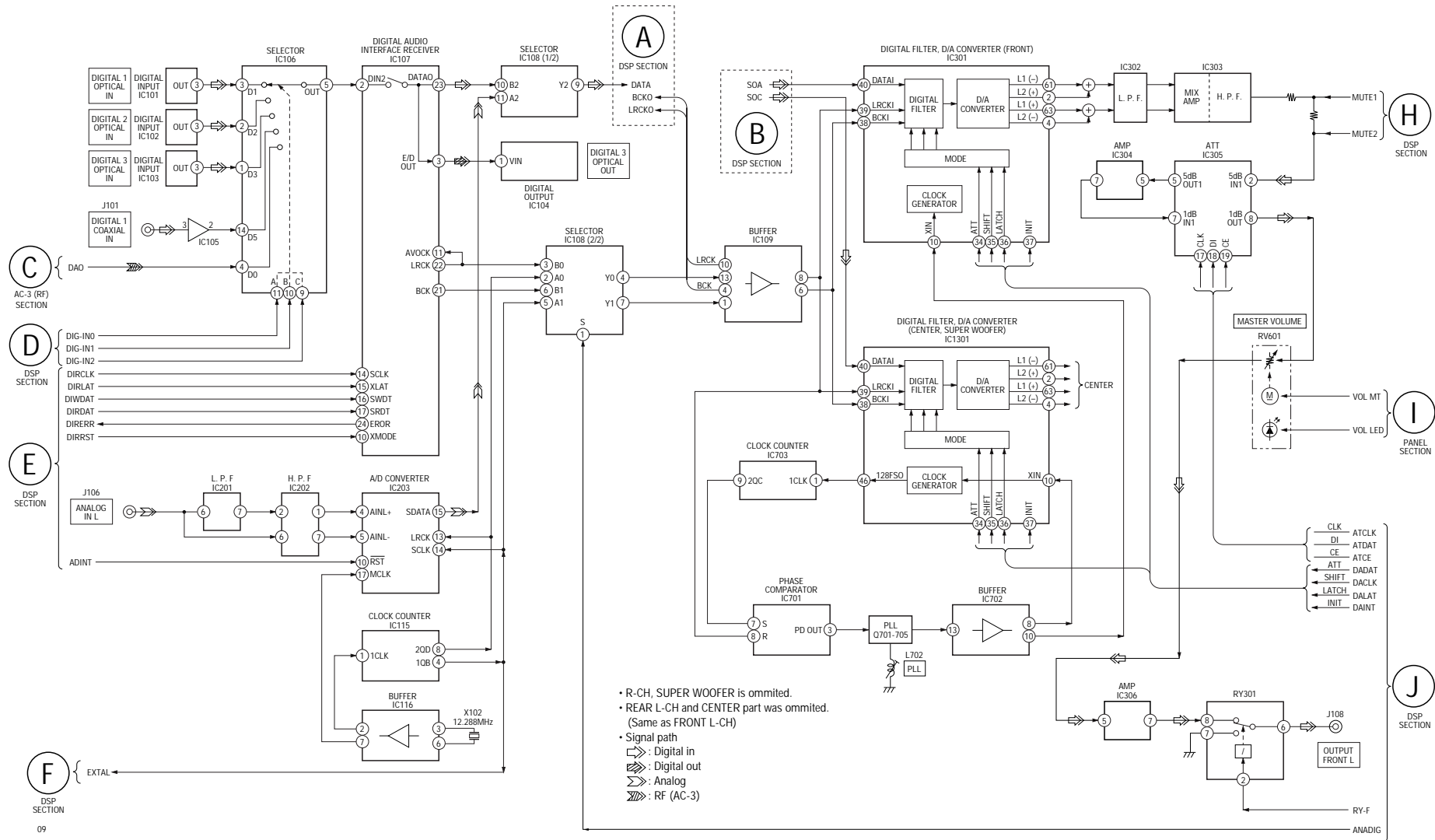

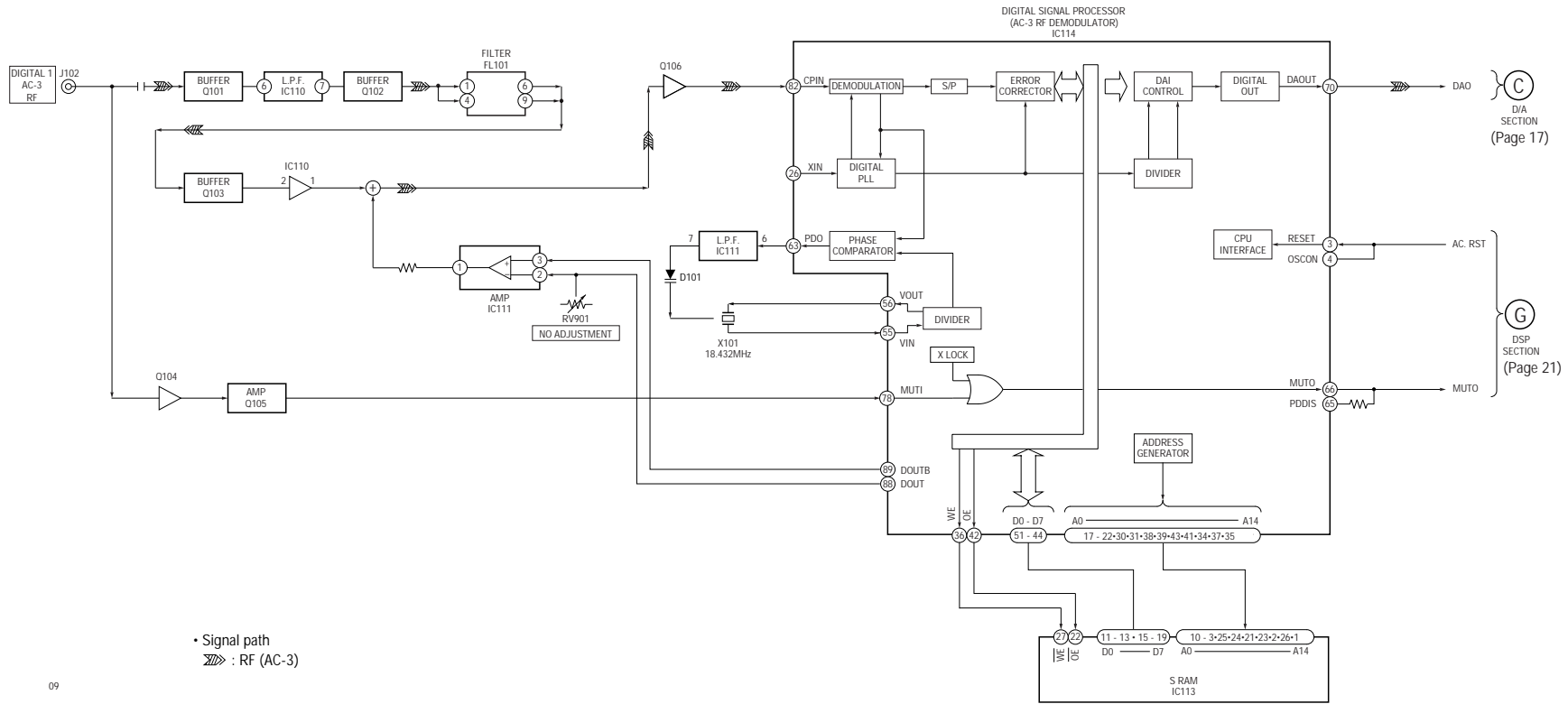

— DISPLAY SECTION —

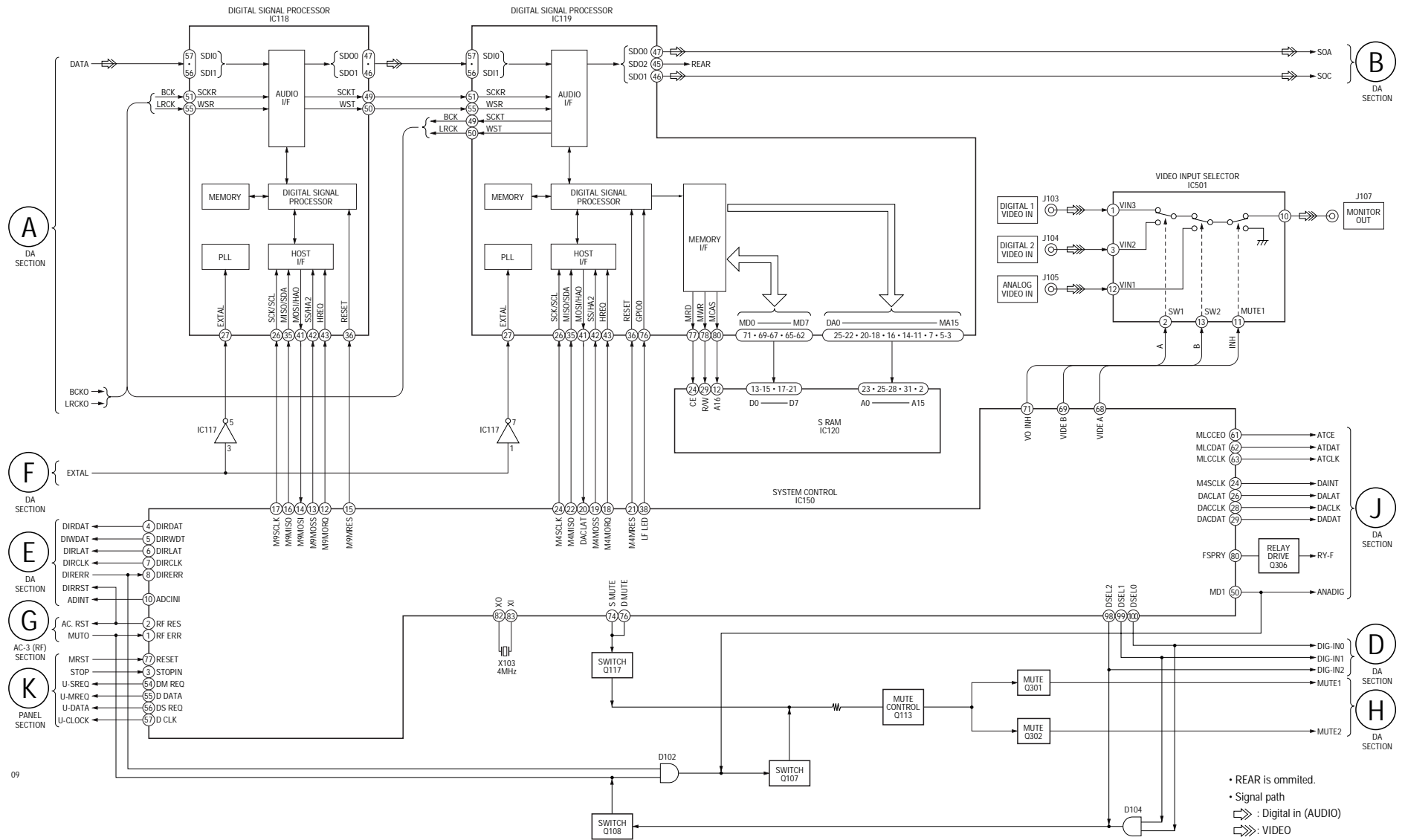

09

— PANEL SECTION —

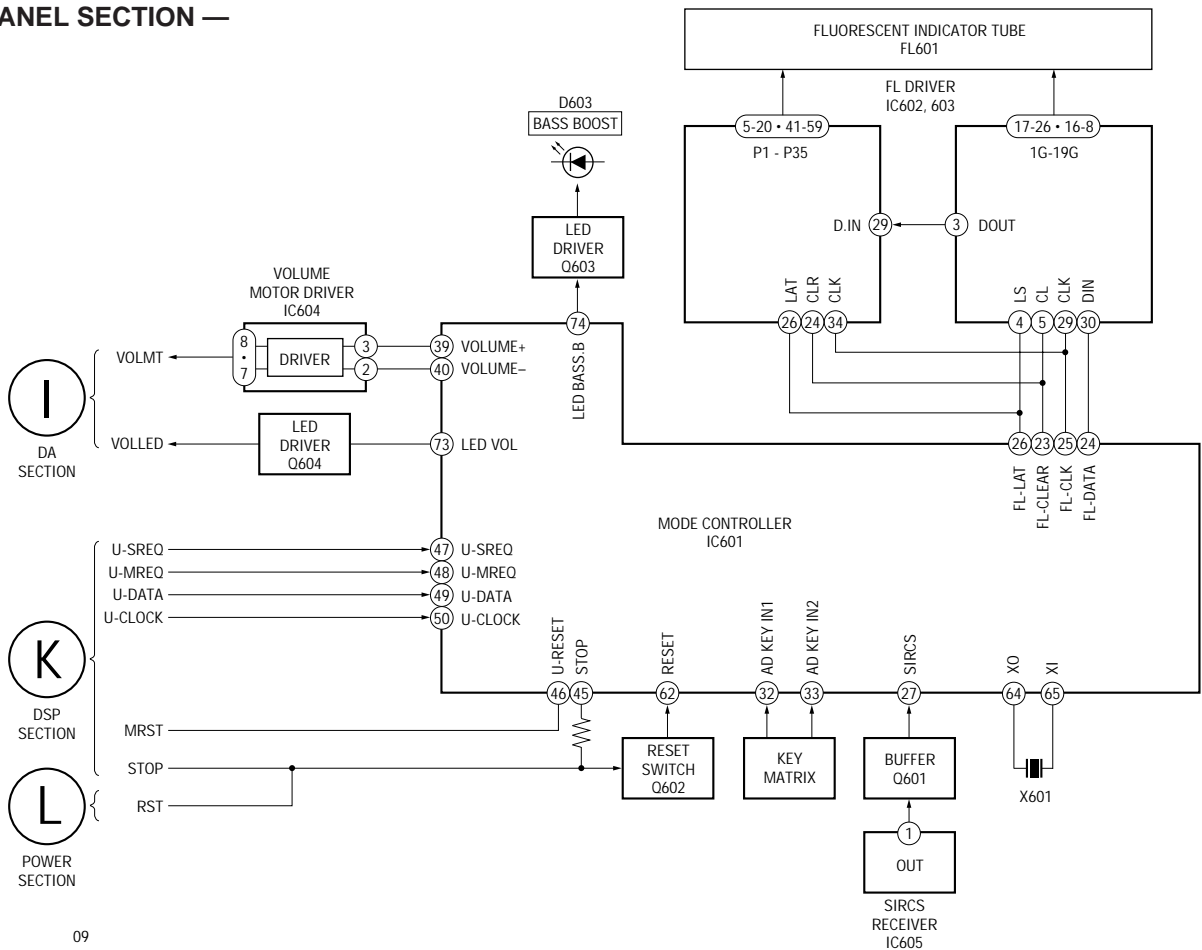

09

— POWER SECTION —

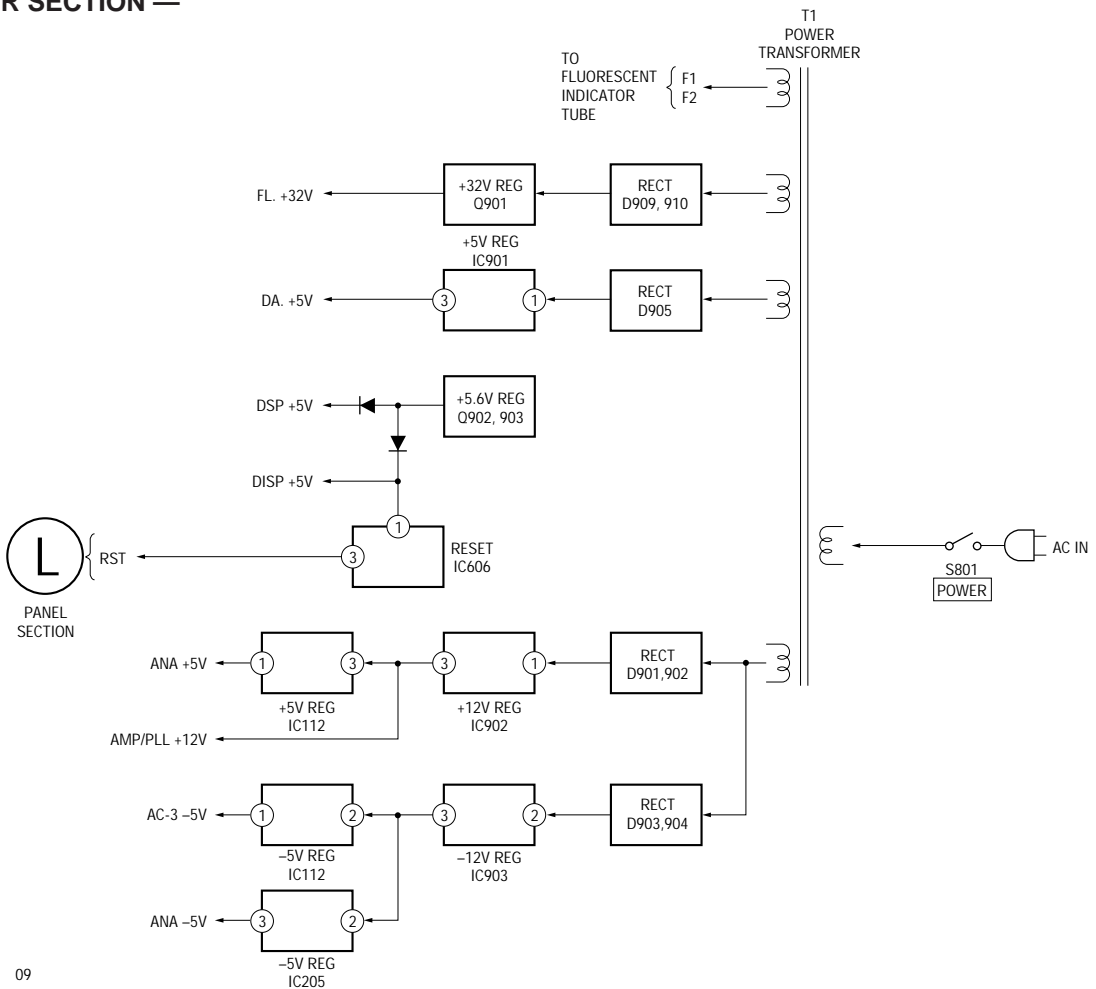

09

4-3. PRINTED WIRING BOARD — MAIN SECTION —
 • See page 14 for Circuit Boards Location.

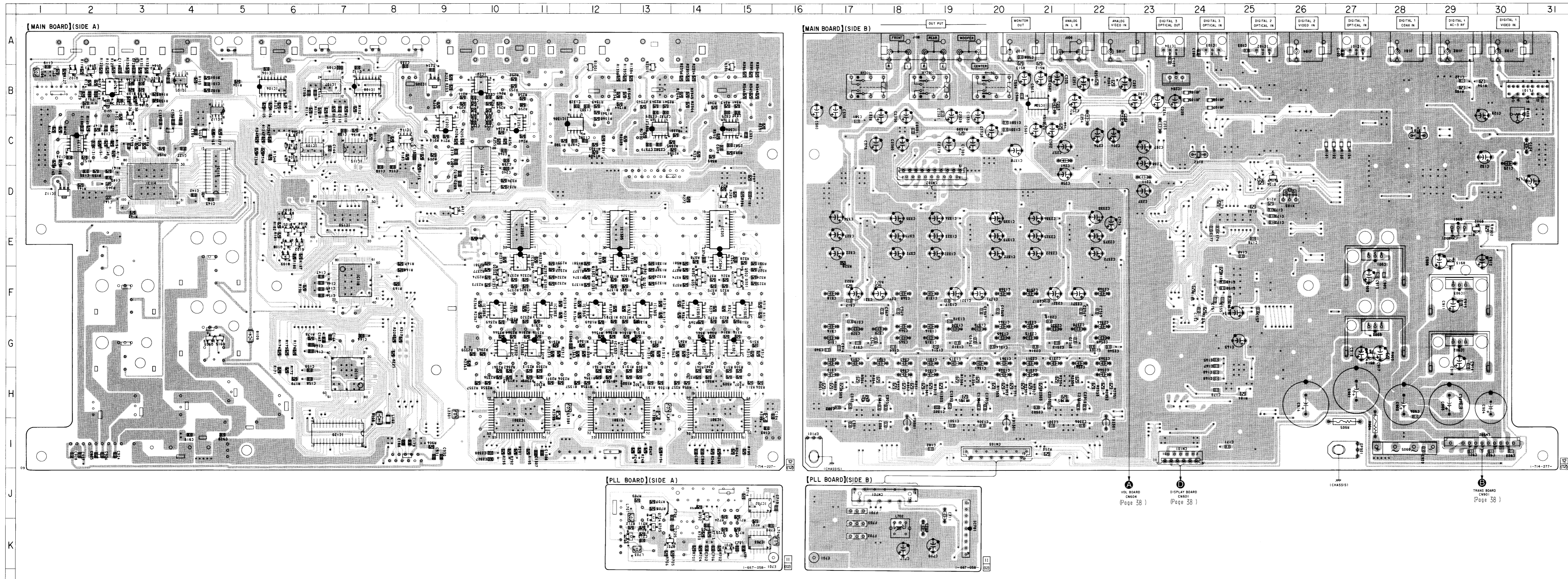

• Semiconductor Location

Ref. No.	Location	Ref. No.	Location
D101	C-3	IC701	K-19
D102	E-6	IC702	J-15
D103	E-6	IC703	K-15
D104	E-6	IC901	E-28
D105	E-6	IC902	G-29
D106	D-25	IC903	F-29
D107	E-10	IC1301	H-12
D108	H-8	IC1302	G-13
D109	G-5	IC1303	F-13
D301	B-15	IC1304	E-13
D701	K-14	IC1305	E-13
D902	E-30	IC1306	C-11
D905	I-28	IC1352	G-12
D915	G-5	IC1353	F-12
D913	E-29	IC2301	I-10
D914	G-27	IC2302	G-11
D1301	B-12	IC2303	F-11
D2301	B-13	IC2304	E-11
		IC2305	E-11
		IC2306	C-13
		IC2352	G-10
		IC2353	F-10
IC101	A-27	Q101	B-2
IC102	A-25	Q102	B-2
IC103	A-24	Q103	B-2
IC104	A-23	Q104	B-3
IC105	B-4	Q105	B-3
IC106	B-6	Q106	B-3
IC107	B-7	Q107	D-6
IC108	B-7	Q108	E-6
IC109	C-6	Q109	D-15
IC110	B-2	Q110	D-9
IC111	C-2	Q301	F-15
IC112	D-1	Q302	F-15
IC113	D-5	Q306	C-6
IC114	D-3	Q351	F-14
IC115	C-7	Q352	K-15
IC116	C-8	Q701	F-14
IC117	C-4	Q702	J-14
IC118	F-4	Q703	J-13
IC119	H-7	Q704	J-13
IC120	I-7	Q705	J-13
IC150	E-7	Q901	E-29
IC201	B-10	Q902	G-28
IC202	C-9	Q903	G-4
IC203	D-10	Q1301	F-13
IC204	B-24	Q1302	F-13
IC205	B-9	Q1351	C-6
IC252	C-10	Q1352	F-12
IC301	H-14	Q2301	F-11
IC302	G-15	Q2302	F-11
IC303	F-15	Q2306	C-6
IC304	E-14	Q2351	F-10
IC305	E-15	Q2352	F-10
IC306	C-15		
IC352	G-14		
IC353	F-14		
IC501	B-21		

Note:
 • : parts extracted from the component side.
 • : parts extracted from the conductor side.
 ○ : Through hole.
 △ : internal component.
 ■ : Pattern from the side which enable seeing.
 (The other layer's patterns are not indicated.)

4-4. SCHEMATIC DIAGRAM — D/A SECTION —
• See page 44 for IC Block Diagrams.

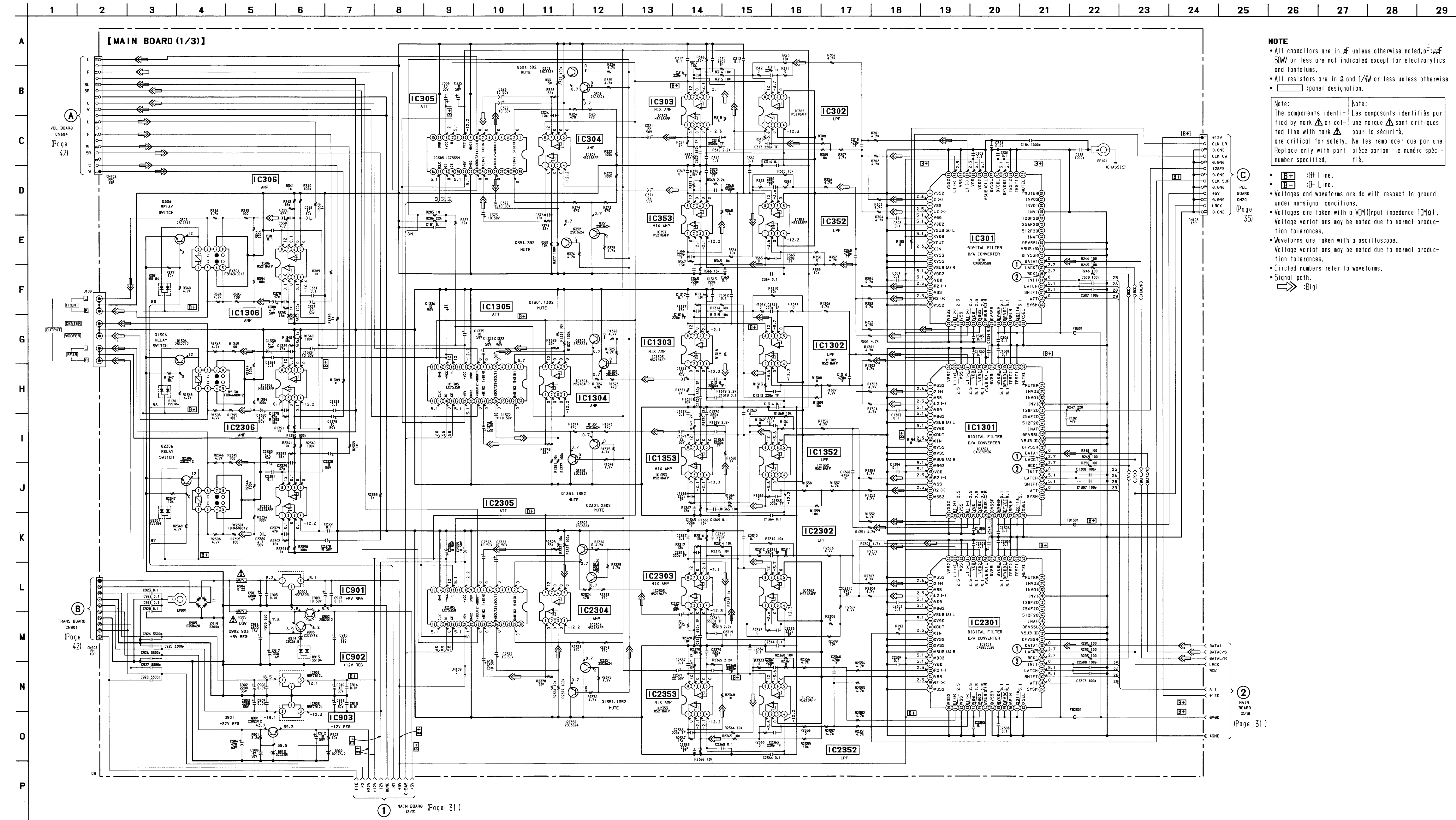

NOTE

- All capacitors are in μF unless otherwise noted, pF: pF
- 50W or less are not indicated except for electrolytics and tantalums.
- All resistors are in Ω and 1/W or less unless otherwise
- \square : panel designation.

Note:
The components identified by mark Δ or dotted line with mark Δ are critical for safety. Replace only with part number specified.

Note:
Les composants identifiés par une marque Δ sont critiques pour la sécurité. Ne les remplacer que par une pièce portant le numéro spécifié.

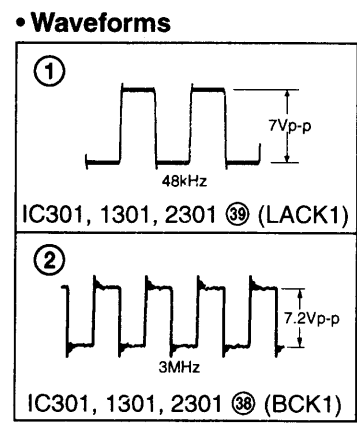

- \square : B Line.
- \square : B Line.
- Voltages and waveforms are dc with respect to ground under no-signal conditions.
- Voltages are taken with a VOM (input impedance 10M Ω). Voltage variations may be noted due to normal production tolerances.
- Waveforms are taken with an oscilloscope. Voltage variations may be noted due to normal production tolerances.
- Circled numbers refer to waveforms.
- Signal path.
- \Rightarrow : Dig

4-5. SCHEMATIC DIAGRAM — CONTROL SECTION —
• See page 23 for Printed Wiring Board.
• See page 44 for IC Block Diagrams.
• See page 48 for IC Pin Functions.

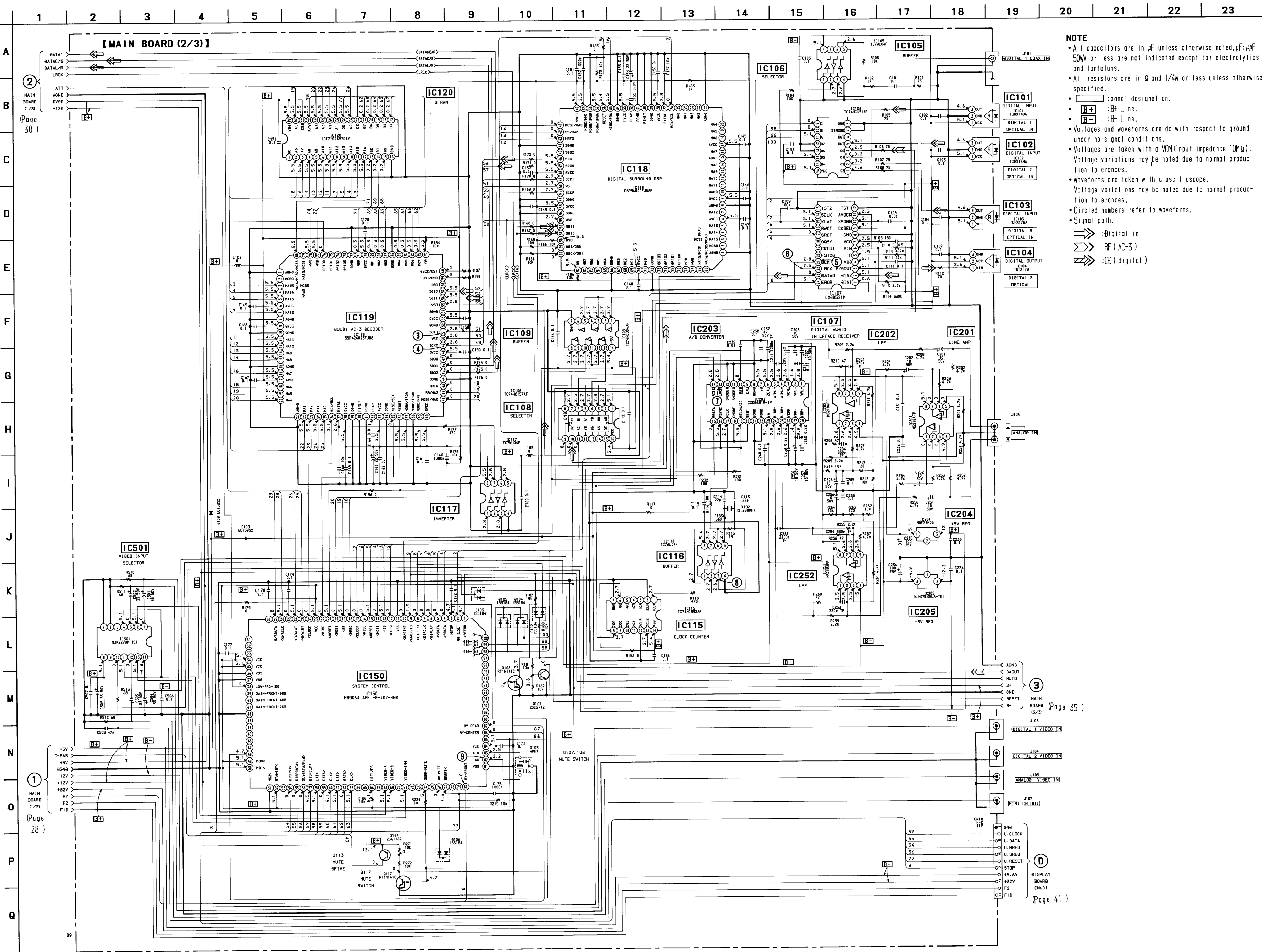

NOTE
• All capacitors are in μF unless otherwise noted. $\text{pF} = \mu\text{F} \times 10^{-6}$.
• All resistors are in Ω and $1/4\text{W}$ or less unless otherwise specified.
• [] : panel designation.
• [H+] : H Line.
• [H-] : B Line.
• Voltages and waveforms are dc with respect to ground under no-signal conditions.
• Voltages are taken with a VOM (input impedance $10\text{M}\Omega$). Voltage variations may be noted due to normal production tolerances.
• Waveforms are taken with an oscilloscope. Voltage variations may be noted due to normal production tolerances.
• Circled numbers refer to waveforms.
• Signal path:
→ : Digital in
→ : RF (AC-3)
→ : (B) (digital)

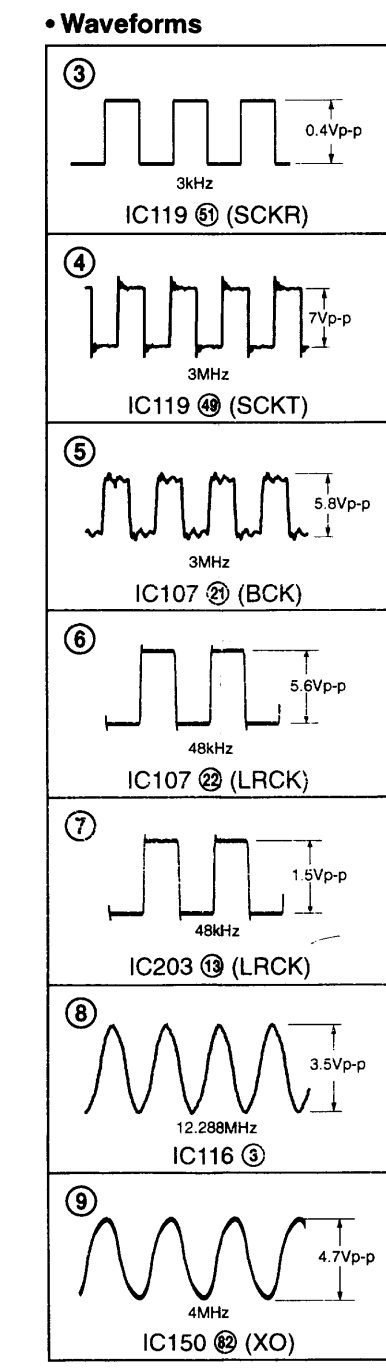

1 MAIN BOARD (1/2) (Page 28)
2 MAIN BOARD (2/3) (Page 30)
3 MAIN BOARD (3/3) (Page 31)

3 MAIN BOARD (3/3) (Page 35)
4 DISPLAY BOARD (Page 41)

4-6. SCHEMATIC DIAGRAM — DOLBY AC-3 SECTION —

- See page 23 for Printed Wiring Board.
- See page 49 for IC Pin Functions.

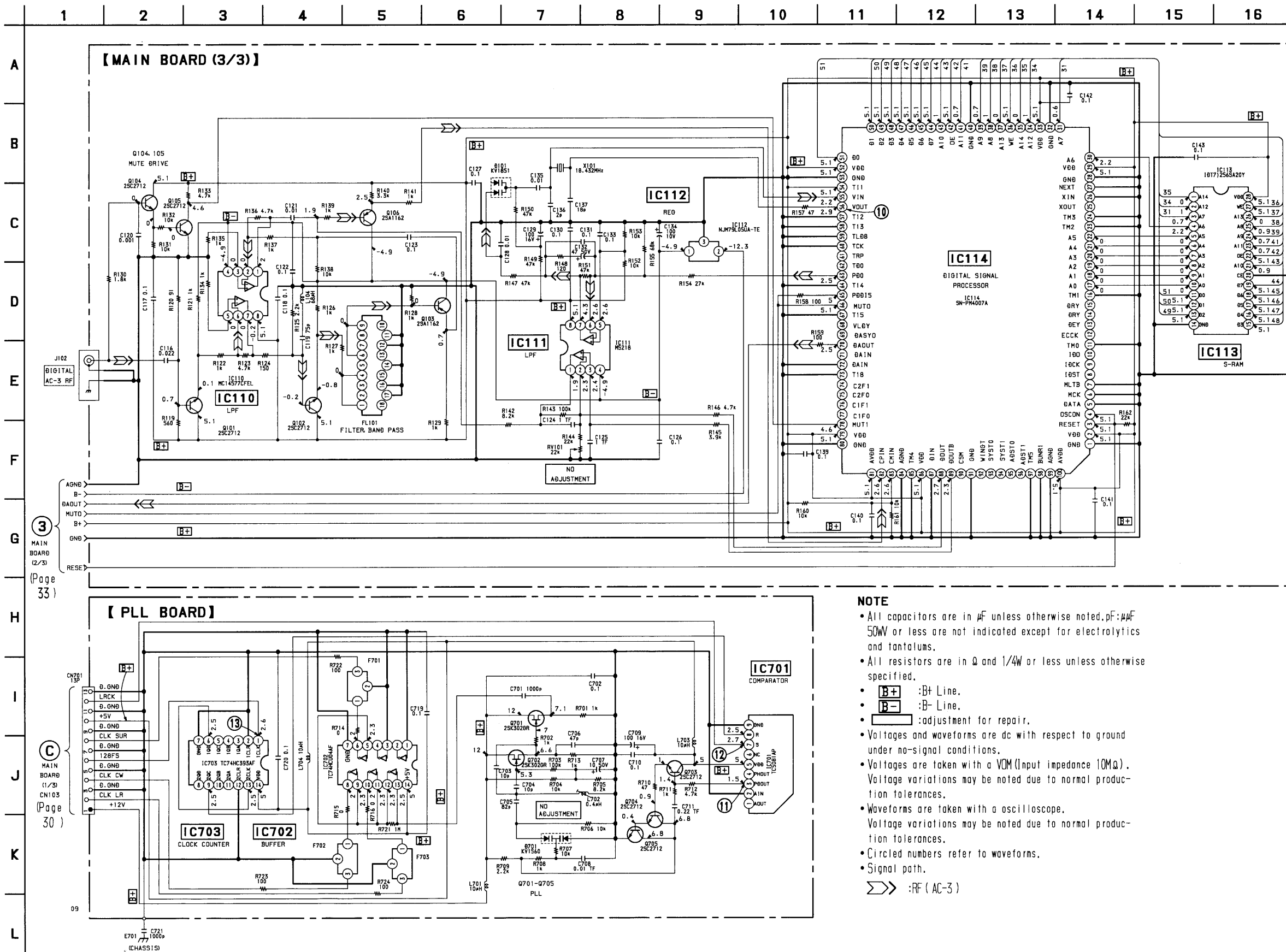

• Waveforms

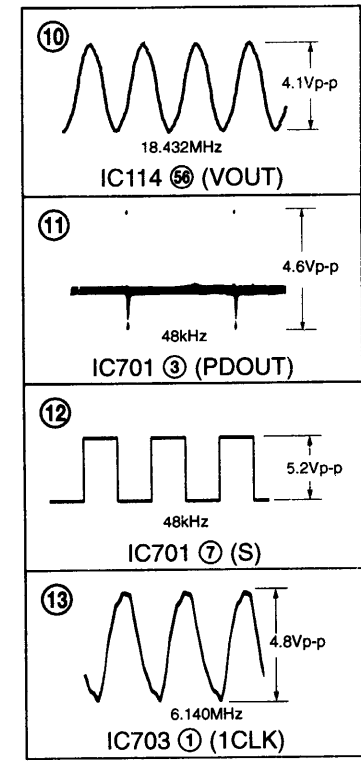

- NOTE**
- All capacitors are in μF unless otherwise noted, pF: μpF 50W or less are not indicated except for electrolytics and tantalums.
 - All resistors are in Ω and 1/4W or less unless otherwise specified.
 - **B+** :B+ Line.
 - **B-** :B- Line.
 - **NO ADJUSTMENT** :adjustment for repair.
 - Voltages and waveforms are dc with respect to ground under no-signal conditions.
 - Voltages are taken with a VOM (Input impedance 10M Ω). Voltage variations may be noted due to normal production tolerances.
 - Waveforms are taken with a oscilloscope. Voltage variations may be noted due to normal production tolerances.
 - Circled numbers refer to waveforms.
 - Signal path.
- \gg :RF (AC-3)

4-7. PRINTED WIRING BOARD — DISPLAY SECTION —
 • See page 14 for Circuit Boards Location.

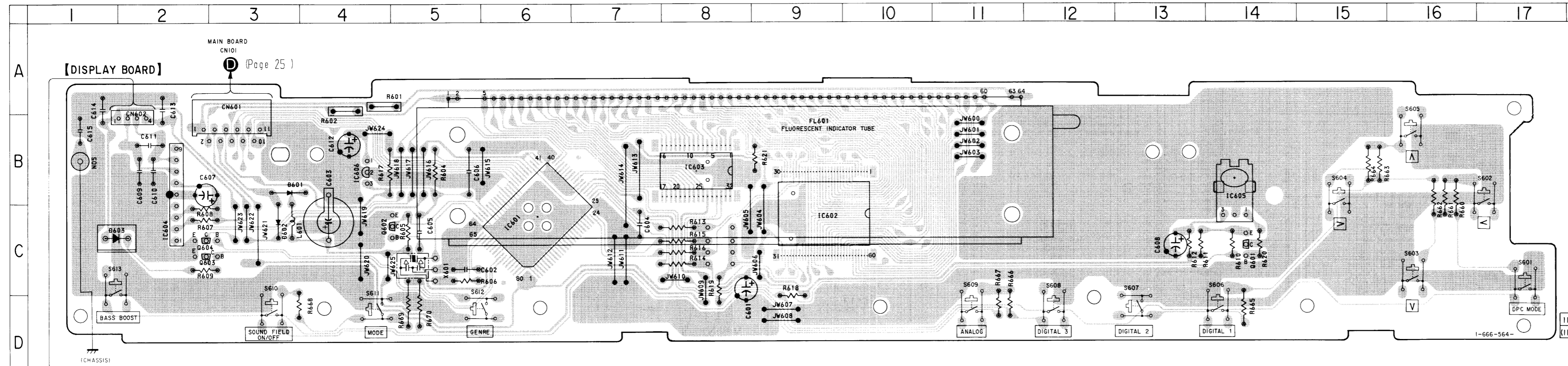

• Semiconductor Location

Ref. No.	Location
D601	B-3
D602	C-3
D603	C-1
D901	H-7
D902	H-7
D903	G-7
D904	G-7
D909	G-7
D910	F-7
D911	G-7
D912	F-7
IC601	C-6
IC602	C-9
IC603	B-8
IC604	C-2
IC605	B-14
IC606	B-4
Q601	C-14
Q602	C-4
Q603	C-2
Q604	C-2

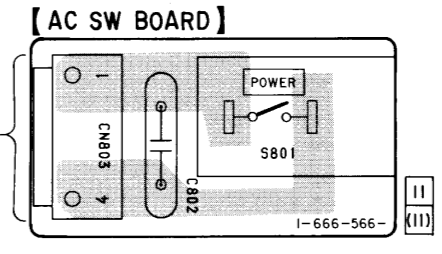
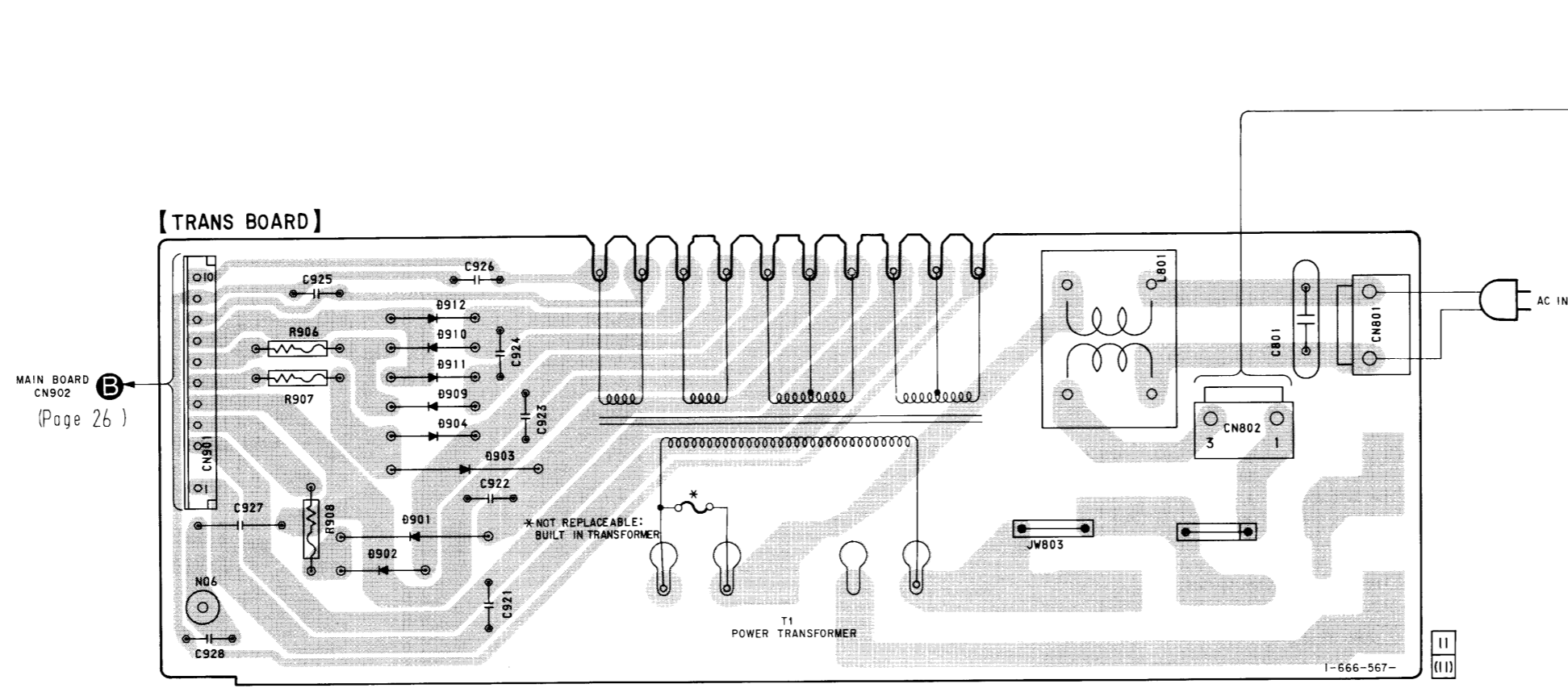
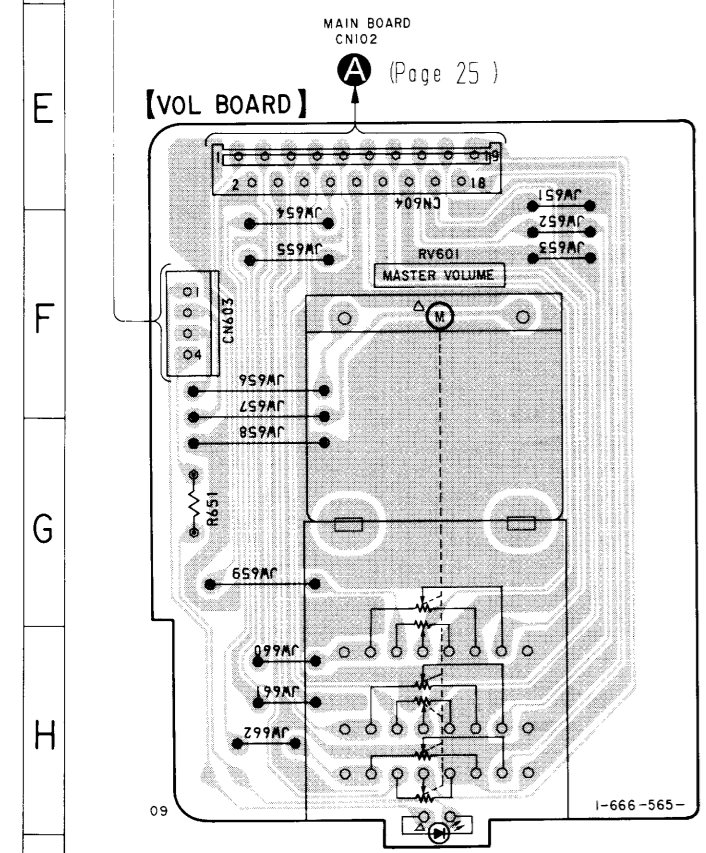

Note:
 • — : parts extracted from the component side.
 • — : parts extracted from the conductor side.
 • Δ : internal component.
 • : Pattern from the side which enable seeing.

4-8. SCHEMATIC DIAGRAM — DISPLAY SECTION —

- See page 46 for IC Block Diagrams.
- See page 60 for IC Pin Functions.

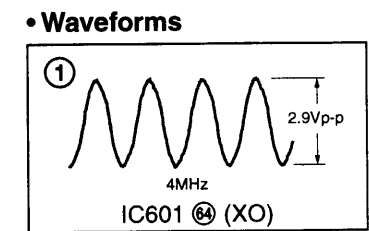
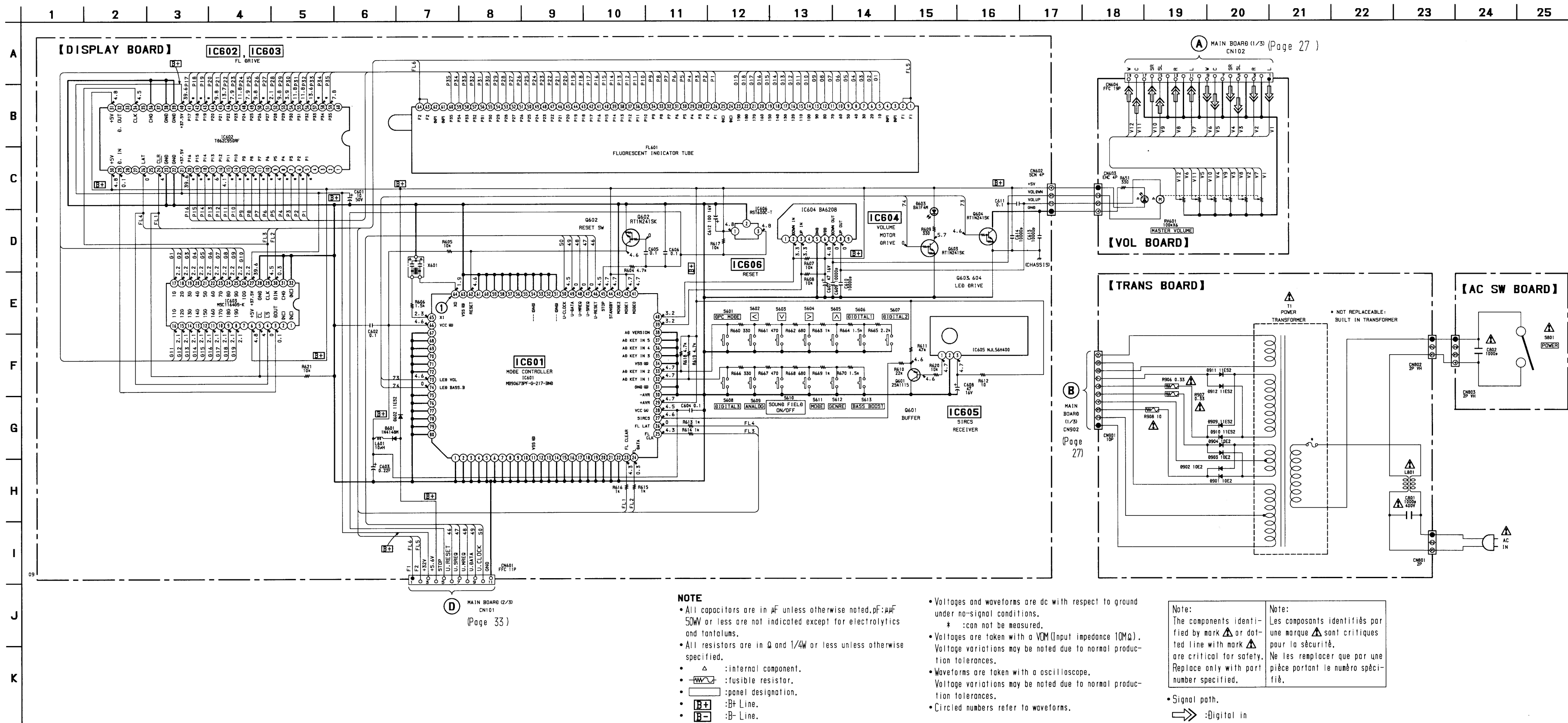

NOTE

- All capacitors are in μF unless otherwise noted, $\text{pF}:\mu\text{F}$ 50W or less are not indicated except for electrolytics and tantalums.
- All resistors are in Ω and $1/4\text{W}$ or less unless otherwise specified.
- Δ : internal component.
- $\text{---}\diagup\diagdown\text{---}$: fusible resistor.
- \square : panel designation.
- B+ : B+ Line.
- B- : B- Line.

- Voltages and waveforms are dc with respect to ground under no-signal conditions.
- * : can not be measured.
- Voltages are taken with a VOM (Input impedance $10\text{M}\Omega$). Voltage variations may be noted due to normal production tolerances.
- Waveforms are taken with an oscilloscope. Voltage variations may be noted due to normal production tolerances.
- Circled numbers refer to waveforms.

Note:
The components identified by mark Δ or dotted line with mark Δ are critical for safety. Replace only with part number specified.

Note:
Les composants identifiés par une marque Δ sont critiques pour la sécurité. Ne les remplacer que par une pièce portant le numéro spécifique.

- Signal path.
- \Rightarrow : Digital in

4-7. IC BLOCK DIAGRAMS

• MAIN SECTION

IC106 TC74HC151AF

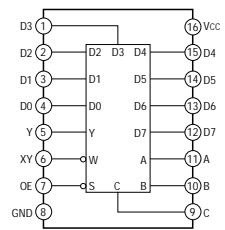

IC108 TC74HC157AF

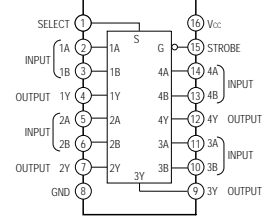

IC109 TC74HCU04AF

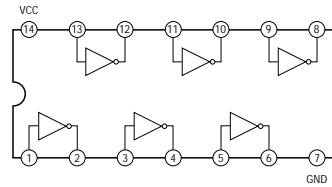

IC115 TC74HC393AF

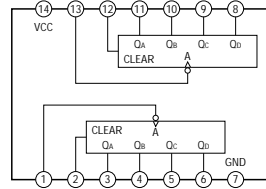

IC203 CXD8681M-TP

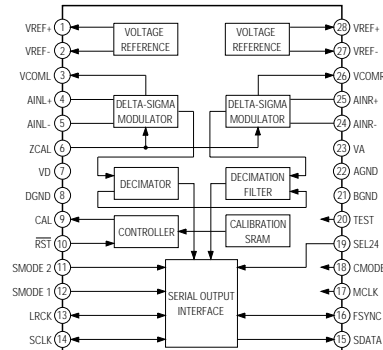

IC301, 1301, 2301 CXD8505BQ

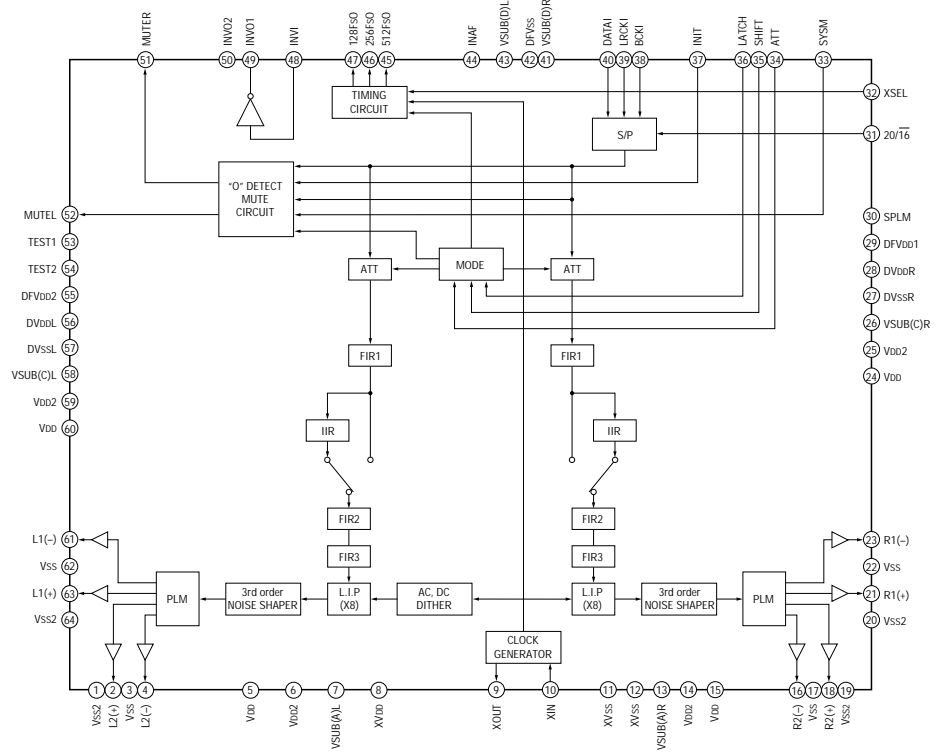

IC305, 1305, 2305 LC7535M

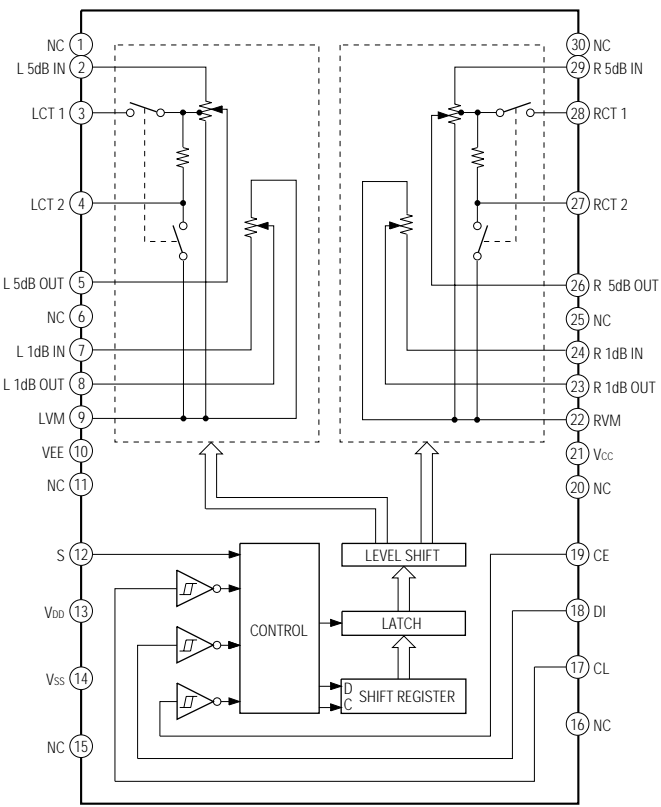

IC701 TC5081AP

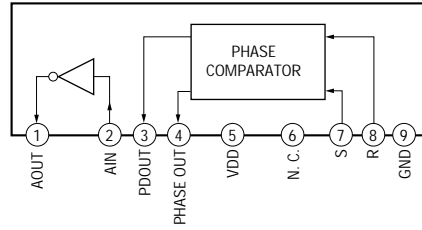

IC501 NJM2279M-TE2

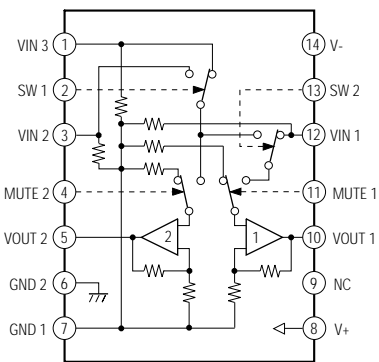

• DISPLAY SECTION

IC602 TD62C950RF

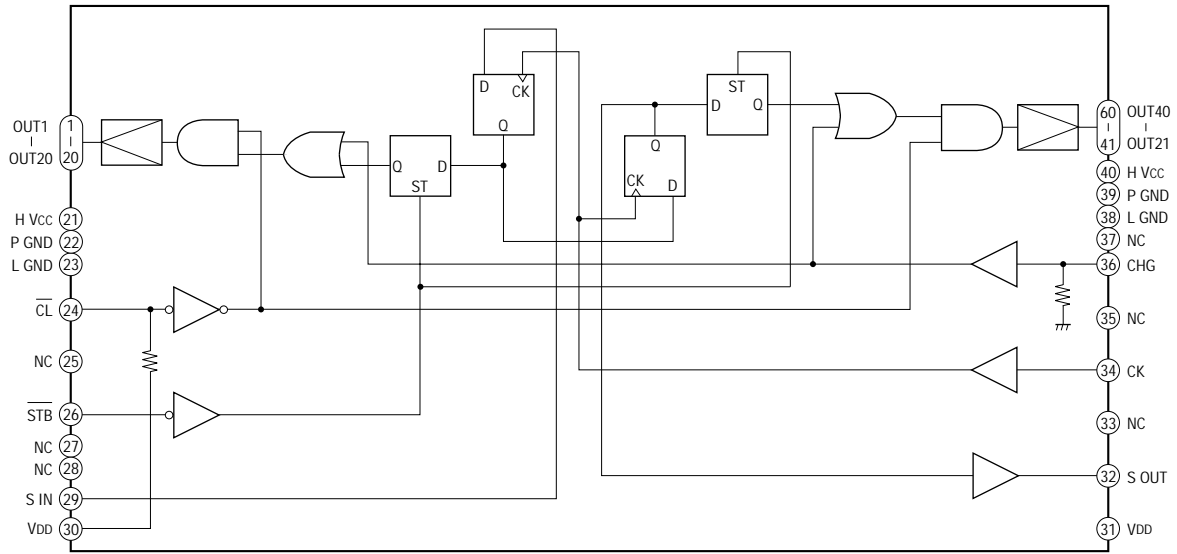

IC603 MSC1164GS-K

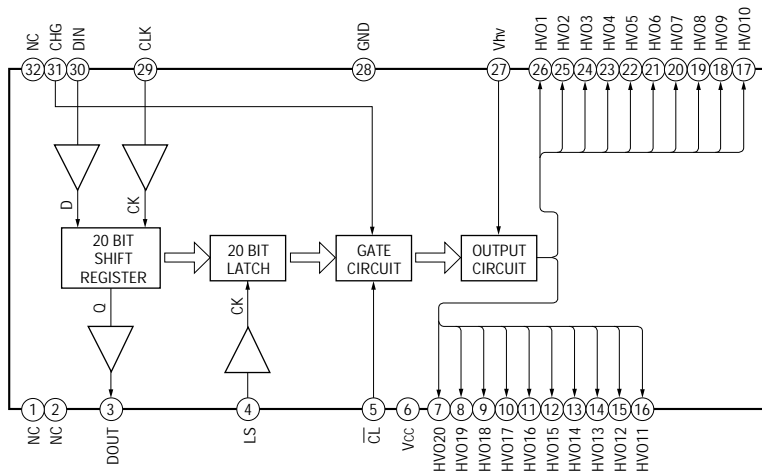

IC604 BA6208

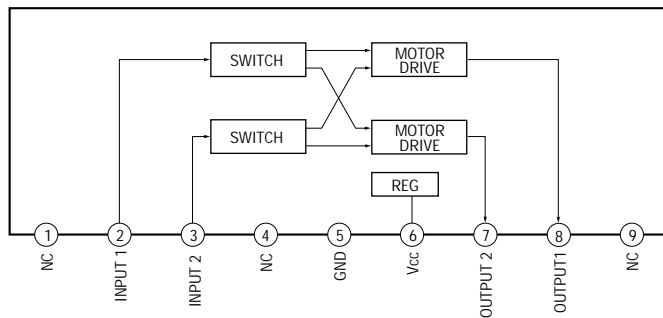

4-10. IC PIN FUNCTIONS

• IC107 Digital Audio Interface Receiver (CXD8521M)

Pin No.	Pin Name	I/O	Function
1	DIN1	I	Data input with built-in amplifier (Responding to the coaxial optical module)
2	DIN2	I	Data input (Responding to the optical module)
3	E/DOUT	O	Emphasis, input bi-phase, validity flag output
4	VDD	–	Power supply (+5V)
5	R	I	VCO gain control input (Fixed at “H”)
6	VIN	I	VCO freerunning frequency setting input
7	VCO	O	LPF setting of PLL (Fixed at “L”)
8	GND	–	Ground
9	CKSEL	I	System clock select input (384fs, 512fs) (Connected to the power supply.)
10	XMODE	I	Reset input
11	AVOCK	I	Clock input for preventing PLL lock failure
12	TST1	I	Test input (Normally “L”)
13	TST2	I	
14	SCLK	I	Microcomputer IF clock input
15	XLAT	I	Microcomputer IF latch/chip enable input
16	SWDT	I	Microcomputer IF write data input
17	SRDT	O	Microcomputer IF read data output
18	DQSY	O	Microcomputer IF Sub-Q sync and ID sync output (Not used)
19	CKOUT	O	VCO clock output (Freerunning, 384fs, 512fs) (Not used)
20	FS128	O	128fs clock output (Not used)
21	BCK	O	Bit clock output
22	LRCK	O	L/R clock output
23	DATAO	O	Audio data output
24	EROR	O	PLL lock error mute output

• IC114 DOLBY AC-3 demodulator (SN-PM4007A)

Pin No.	Pin Name	I/O	Function
1	GND	–	Ground
2	VDD	–	+5V power supply
3	RESET	I	System reset input “L” : reset
4	OSCON	I	Oscillation control signal input “H” : ON
5	DATA	I	Test pin (Connected to ground)
6	MCK	I	Test pin (Connected to ground)
7	MLTB	I	Test pin (Connected to ground)
8	IDST	O	Test pin (Open)
9	IDCK	O	Test pin (Open)
10	IDO	O	Test pin (Open)
11	TM0	I	Test pin (Connected to ground)
12	ECCK	O	Test pin (Open)
13	DEN	O	Test pin (Open)
14	DRY	O	Test pin (Open)
15	MSYC	O	Test pin (Open)
16	TM1	I	Test pin (Connected to ground)
17	A0	O	Address data output to SRAM
18	A1	O	Address data output to SRAM
19	A2	O	Address data output to SRAM
20	A3	O	Address data output to SRAM
21	A4	O	Address data output to SRAM
22	A5	O	Address data output to SRAM
23	TM2	I	Test pin (Connected to ground)
24	TM3	I	Test pin (Connected to ground)
25	XOUT	O	Test pin (Open)
26	XIN	I	Test pin (Connected to ground)
27	XENT	I	Test pin (Connected to ground)
28	GND	–	Ground
29	VDD	–	+5V power supply
30	A6	O	Address data output to SRAM
31	A7	O	Address data output to SRAM
32	GND	–	Ground
33	VDD	–	+5V power supply
34	A12	O	Address data output to SRAM
35	A14	O	Address data output to SRAM
36	WE	O	Write enable signal output to SRAM “L” : active
37	A13	O	Address data output to SRAM
38	A8	O	Address data output to SRAM
39	A9	O	Address data output to SRAM
40	GND	–	Ground
41	A11	O	Address data output to SRAM
42	OE	O	Output enable output to SRAM
43	A10	O	Address data output to SRAM
44	D7	I/O	Data bus input/output with SRAM
45	D6	I/O	Data bus input/output with SRAM
46	D5	I/O	Data bus input/output with SRAM
47	D4	I/O	Data bus input/output with SRAM
48	D3	I/O	Data bus input/output with SRAM
49	D2	I/O	Data bus input/output with SRAM
50	D1	I/O	Data bus input/output with SRAM

Pin No.	Pin Name	I/O	Function
51	D0	I/O	Data bus input/output with SRAM
52	VDD	–	+5V power supply
53	GND	–	Ground
54	TI1	I	Test pin (Connected to VDD)
55	VIN	I	VCXO input (18.432MHz)
56	VOUT	O	VCXO output (18.432MHz)
57	TI2	I	Test pin (Connected to Ground)
58	TI3	I	Test pin (Connected to Ground)
59	TLDS8	I	Test pin (Connected to Ground)
60	TCK	I	Test pin (Connected to Ground)
61	TRP	O	Test pin (Open)
62	TD0	O	Test pin (Open)
63	PD0	O	Output of internal phase comparator (3 state)
64	TI4	I	Test pin (Connected to Ground)
65	PDDIS	I	PDO output control input “L” : output ON
66	MUTO	O	Mute signal output “H” : mute
67	TI5	I	Test pin (Connected to Ground)
68	VLDY	O	Test pin (Open)
69	DASYO	O	Test pin (Open)
70	DAOUT	O	Digital-out signal output (Serial data stream output)
71	DAIN	I	Digital external input Through out to DAOUT when DASEL is “H” (Not used)
72	DASEL	I	Digital-out selection input (Not used)
73	TI8	I	Test pin (Connected to Ground)
74	C2F1	O	C2 error correction state display Outputs if corrected properly (Not used)
75	C2F0	O	C2 error correction state display Outputs number of errors at C2 (Not used)
76	C1F1	O	C2 error correction state display Outputs whether error is present at C1 (Not used)
77	C1F0	O	C2 error correction state display Outputs number of errors at C1 (Not used)
78	MUTI	I	Muting input “H” mute
79	VDD	–	+5V power supply
80	GND	–	Ground
81	AVDD	–	+5V power supply (Analog)
82	CPIN	I	Comparator input (+) (QPSK input)
83	CMIN	I	Comparator input (–)
84	AGND	–	Ground (Analog)
85	TM4	I	Test pin (Connected to ground)
86	VDD	–	+5V power supply
87	DIN	I	Test pin (Connected to ground)
88	DOUT	O	Compare output
89	DOUTB	O	Compare inverted output
90	C9M	O	9.216MHz output (Open)
91	GND	–	Ground
92	WINGT	O	Test pin (Connected to ground)
93	SYST0	O	Test pin (Connected to ground)
94	SYST1	O	Test pin (Connected to ground)
95	ADST0	O	Test pin (Connected to ground)
96	ADST1	O	Test pin (Connected to ground)
97	TM5	I	Test pin (Open)
98	BUNRI	I	Test pin (Open)
99	AGND	–	Ground (Analog)
100	AVDD	–	+5V power supply (Analog)

• IC118 DOLBY AC-3 decoder (DSP56009FJ88)

Pin No.	Pin Name	I/O	Function
1	AGND	–	Address buffer ground
2	MCS0	O	Chip select 0 output to S-RAM (Not used)
3	MA15	O	Address data output to S-RAM (Not used)
4	MA14	O	
5	MA13	O	
6	AVCC	–	Address bus buffer power supply (+5V)
7	MA12	O	Address data output to S-RAM(Not used)
8	AGND	–	Ground for address bus buffer
9	QVCC	–	Power supply for internal logic (+5V)
10	QGND	–	Ground for internal logic
11	MA11	O	Address data output to S-RAM (Not used)
12	MA10	O	
13	MA9	O	
14	MA8	O	
15	AGND	–	Ground for address bus buffer
16	MA7	O	Address data output to S-RAM (Not used)
17	AVCC	–	Power supply for address bus buffer (+5V)
18	MA6	O	Address data output to S-RAM (Not used)
19	MA5	O	
20	MA4	O	
21	AGND	–	Ground for address bus buffer
22	MA3	O	Address data output to S-RAM (Not used)
23	MA2	O	
24	MA1	O	
25	MA0	O	
26	SCK/SCL	I	SPI serial clock signal input from system controller
27	EXTAL	I	External frequency input (3 MHz)
28	QVCC	–	Power supply for internal logic (+5V)
29	QGND	–	Ground for internal logic
30	PINIT	I	PLL initialize input (Fixed at “L”)
31	PGND	–	Ground for PLL
32	PCAP	I	PLL filter input (Connected to 0.01 μ F capacitor)
33	PVCC	–	Power supply for PLL (+5V)
34	SGND	–	Ground for serial port
35	MISO/SDA	I	Master data signal input from system controller
36	RESET	I	Reset signal input from system controller
37	MODA/IRQA	I	Mode select A (Fixed at “H”)
38	MODB/IRQB	I	Mode select B (Fixed at “L”)
39	MODC/NMI	I	Mode select C (Fixed at “H”)
40	SVCC	–	Power supply for serial port (+5V)

Pin No.	Pin Name	I/O	Function
41	MOSI/HA0	O	Master data signal output to system controller
42	SS/HA2	I	SPI slave select signal input from system controller
43	HREQ	I	Host request signal input from system controller
44	SGND	–	Ground for serial port
45	SDO2	O	Audio serial data 2 signal output (Not used)
46	SDO1	O	Audio serial data 1 signal output
47	SDO0	O	Audio serial data 0 signal output
48	SVCC	–	Power supply for serial port (+5V)
49	SCKT	O	Serial clock transmission
50	WST	O	Word select transmission
51	SCKR	I	Serial clock reception
52	QGND	–	Ground for internal logic
53	QVCC	–	Power supply for internal logic (+5V)
54	SGND	–	Ground for serial port
55	WSR	I	Word select reception
56	SDI1	I	Audio serial data 1 signal input
57	SDI0	I	Audio serial data 0 signal input
58	DSO	O	Debug serial signal output (Not used)
59	DSI	I	Debug serial signal input (Not used)
60	DSCK	I	Debug serial clock signal input (Not used)
61	DR	I	Debug request input (Fixed at “H”)
62	MD7	I/O	Data input/output with S-RAM (Not used)
63	MD6	I/O	
64	MD5	I/O	
65	MD4	I/O	
66	DGND	–	Ground for data bus buffer
67	MD3	I/O	Data input/output with S-RAM (Not used)
68	MD2	I/O	
69	MD1	I/O	
70	DVCC	–	Power supply for data bus buffer (+5V)
71	MD0	I/O	Data input/output with S-RAM (Not used)
72	DGND	–	Ground for data bus buffer
73	GPIO3	I/O	General DSP input/output (Not used)
74	GPIO2	I/O	
75	GPIO1	I/O	
76	GPIO0	I/O	
77	MRD	O	Write strobe signal output to S-RAM (Not used)
78	MWR	O	Read strobe signal output to S-RAM (Not used)
79	MA15/MCS1	O	Low address strobe signal output to S-RAM (Not used)
80	MA16/MCS2/MCAS	O	Column address strobe signal output to S-RAM (Not used)

• IC119 DOLBY Surround Digital Signal Processor (SSP424023FJ88)

Pin No.	Pin Name	I/O	Function
1	AGND	–	Address buffer ground
2	MCS0	O	Chip select 0 output to S-RAM (Not used)
3	MA15	O	Address data output to S-RAM
4	MA14	O	
5	MA13	O	
6	AVCC	–	Address bus buffer power supply (+5V)
7	MA12	O	Address data output to S-RAM
8	AGND	–	Ground for address bus buffer
9	QVCC	–	Power supply for internal logic (+5V)
10	QGND	–	Ground for internal logic
11	MA11	O	Address data output to S-RAM
12	MA10	O	
13	MA9	O	
14	MA8	O	
15	AGND	–	Ground for address bus buffer
16	MA7	O	Address data output to S-RAM
17	AVCC	–	Power supply for address bus buffer (+5V)
18	MA6	O	Address data output to S-RAM
19	MA5	O	
20	MA4	O	
21	AGND	–	Ground for address bus buffer
22	MA3	O	Address data output to S-RAM
23	MA2	O	
24	MA1	O	
25	MA0	O	
26	SCK/SCL	I	SPI serial clock signal input from system controller
27	EXTAL	I	External frequency input (3 MHz)
28	QVCC	–	Power supply for internal logic (+5V)
29	QGND	–	Ground for internal logic
30	PINIT	I	PLL initialize input (Fixed at “L”)
31	PGND	–	Ground for PLL
32	PCAP	I	PLL filter input (Connected to 0.01 μ F capacitor)
33	PVCC	–	Power supply for PLL (+5V)
34	SGND	–	Ground for serial port
35	MISO/SDA	I	Master data signal input from system controller
36	RESET	I	Reset signal input from system controller
37	MODA/IRQA	I	Mode select A (Fixed at “H”)
38	MODB/IRQB	I	Mode select B (Fixed at “L”)
39	MODC/NMI	I	Mode select C (Fixed at “H”)
40	SVCC	–	Power supply for serial port (+5V)

Pin No.	Pin Name	I/O	Function
41	MOSI/HA0	O	Master data signal output to system controller
42	SS/HA2	I	SPI slave select signal input from system controller
43	HREQ	I	Host request signal input from system controller
44	SGND	–	Ground for serial port
45	SDO2	O	Audio serial data 2 signal output
46	SDO1	O	Audio serial data 1 signal output
47	SDO0	O	Audio serial data 0 signal output
48	SVCC	–	Power supply for serial port (+5V)
49	SCKT	O	Serial clock transmission
50	WST	O	Word select transmission
51	SCKR	I	Serial clock reception
52	QGND	–	Ground for internal logic
53	QVCC	–	Power supply for internal logic (+5V)
54	SGND	–	Ground for serial port
55	WSR	I	Word select reception
56	SDI1	I	Audio serial data 1 signal input
57	SDI0	I	Audio serial data 0 signal input
58	DSO	O	Debug serial signal output (Not used)
59	DSI/OS0	I	Debug serial signal input (Not used)
60	DSCK/OS1	I	Debug serial clock signal input (Not used)
61	DR	I	Debug request input (Fixed at “H”)
62	MD7	I/O	Data input/output with S-RAM
63	MD6	I/O	
64	MD5	I/O	
65	MD4	I/O	
66	DGND	–	Ground for data bus buffer
67	MD3	I/O	Data input/output with S-RAM
68	MD2	I/O	
69	MD1	I/O	
70	DVCC	–	Power supply for data bus buffer (+5V)
71	MD0	I/O	Data input/output with S-RAM
72	DGND	–	Ground for data bus buffer
73	GPIO3	I/O	General DSP input/output (Not used)
74	GPIO2	I/O	
75	GPIO1	I/O	
76	GPIO0	O	General DSP output to system controller
77	MRD	O	Write strobe signal output to S-RAM
78	MWR	O	Read strobe signal output to S-RAM
79	MA15/MCS1	O	Low address strobe signal output to S-RAM (Not used)
80	MA16/MCS2/MCAS	O	Column address strobe signal output to S-RAM

• IC150 System Controller (MB90641APF-G-102-BND)

Pin No.	Pin Name	I/O	Function
1	RF ERR	I	Error input from DOLBY AC-3 demodulator "H" : error
2	RF RES	O	Reset output to DOLBY AC-3 demodulator "L" : reset
3	STOPIN	I	Power supply failure detection input
4	DIRDAT	I	Data read signal input from CXD8521M
5	DIRWDT	O	Data write signal output to CXD8521M
6	DIRLAT	O	Latch output to CXD8521
7	DIRCLK	O	Clock output to CXD8521
8	DIRERR	I	Error signal input from CXD8521M "H" : error
9	ANADIG	O	Analog/Digital switching, Digital at "H"
10	ADCINI	O	Initialize output to A/D converter
11	VSS	–	Ground
12	M9MORQ	O	Host request signal output to DSP56009FJ88
13	M9MOSS	O	SPI slave select signal output to DSP56009FJ88
14	M9MOSI	O	Master data signal output to DSP56009FJ88
15	M9MRES	O	Reset signal output to DSP56009FJ88 "L" : reset
16	M9MISO	I	Master data signal input from DSP56009FJ88
17	M9SCLK	O	SPI serial clock output to DSP56009FJ88
18	M4MORQ	O	Host request signal output to SSP424023FJ88
19	M4MOSS	O	SPI slave select signal output to SSP424023FJ88
20	M4MOSI	O	Master data signal output to SSP424023FJ88
21	M4MRES	O	Reset signal output to SSP424023FJ88 "L" : reset
22	M4MISO	I	Master data signal input from SSP424023FJ88
23	VCC	–	+5V power supply
24	M4SCLK	O	SPI serial clock output to SSP424023FJ88
25	DACINI	O	Initialize output to CXD8505BQ "L" : initialize
26	DACLAT	O	Latch output to CXD8505BQ
27	–	–	Not used
28	DACCLK	O	Clock output to CXD8505BQ
29	DACDAT	O	Data output to CXD8505BQ
30	–	O	Initialize output "L" : initialize (Not used)
31	–	–	Not used
32	–	–	Not used
33	–	–	Not used
34	VCC	–	+5V power supply
35	VCC	–	+5V power supply
36	VSS	–	Ground
37	VSS	–	Ground
38	LF LED	I	Low frequency LED signal input from SSP424023FJ88
39	–	–	Not used
40	–	–	Not used
41	–	–	Not used
42	VSS	–	Ground
43	–	–	Not used
44	–	–	Not used
45	–	–	Not used
46	–	–	Not used
47	–	–	Not used
48	STOPIN	I	Power supply failure detection input
49	MD0	I	Normary, connected to +5V
50	MD1	I	Normary, connected to +5V

Pin No.	Pin Name	I/O	Function
51	MD2	I	Normary, connected to ground
52	STANDBY	–	Normary, connected to +5V
53	–	–	Not used
54	DM REQ	I	Master request signal input from mode controller
55	D DATA	I	Master data input from mode controller
56	DS REQ	O	Slave data request signal output to mode controller
57	D CLK	I	Master clock input from mode controller
58	LC CEO	O	Latch output to ATT (Rear, Center, woofer)
59	LC DAT	O	Signal data output to ATT (Rear, Center, woofer)
60	LC CLK	O	Signal clock output to ATT (Rear, Center, woofer)
61	MLC CEO	O	Latch output to ATT (Front)
62	MLC DAT	O	Signal data output to ATT (Front)
63	MLC CLK	O	Signal clock output to ATT (Front)
64	–	–	Not used
65	–	–	Not used
66	–	–	Not used
67	–	–	Not used
68	VIDE A	O	Video-input switching signal output
69	VIDE B	O	Video-input switching signal output
70	–	–	Not used
71	VO INH	O	Video-out inhibit signal output “L” : inhibit
72	–	–	Not used
73	–	–	Not used
74	S MUTE	O	Surround muting signal output “H” : mute
75	–	–	Not used
76	D MUTE	O	-20dB muting signal output “H” : mute
77	RESET	I	Reset signal input “L” : reset
78	–	–	Not used
79	–	–	Not used
80	FSP RY	O	Front speaker relay switching output “H” : ON
81	VSS	–	Ground
82	XO	O	System clock output (4MHz)
83	XI	I	System clock input (4MHz)
84	VCC	–	+5V power supply
85	–	–	Not used
86	CSP-RY	O	Center speaker/Super woofer relay switching output “H” : ON
87	RSP RY	O	REAR speaker relay switching output “H” : ON
88	–	–	Not used
89	–	–	Not used
90	–	–	Not used
91	–	–	Not used
92	–	–	Not used
93	–	–	Not used
94	–	–	Not used
95	–	–	Not used
96	–	–	Not used
97	–	–	Not used
98	DSEL2	O	Digital-input selection signal output
99	DSEL1	O	Digital-input selection signal output
100	DSEL0	O	Digital-input selection signal output

• IC203 A/D Converter (CXD8681M-TP)

Pin No.	Pin Name	I/O	Function
1	VRL+	O	L-ch reference voltage (+) output (+3.75V)
2	VRL-	O	L-ch reference voltage (-) output (+1.25V)
3	VCML	O	L-ch common voltage (+) output (+2.5V)
4	AINL+	I	L-ch analog voltage (+) input
5	AINL-	I	L-ch analog voltage (-) input
6	ZCAL	I	Zero calibration input (Fixed at "H")
7	VD	-	+5.5V power supply (Digital)
8	DGND	-	Ground (Digital)
9	CAL	O	Calibration status signal output
10	RST	I	Reset input "L" : reset
11	SMODE2	I	Serial interface mode selection input (Fixed at "L")
12	SMODE1	I	Serial interface mode selection input (Fixed at "L")
13	LRCK	I/O	L/R channel selection clock input/output
14	SCLK	I/O	Serial data clock input/output
15	SDATA	O	Serial data output
16	FSYNC	I/O	Frame sync clock input/output (Not used)
17	MCLK	I	Master clock input (12.288MHz)
18	CMODE	I	Master clock selection input "L" : MCLK : 256Fs, "H" : MCLK : 384Fs (Fixed at "L")
19	SEL24/20	I	Output data range selection input "L" : 20 bit, "H" ; 24 bit (Fixed at "H")
20	TEST	I	Test pin (Fixed at "L")
21	BGND	-	Ground
22	AGND	-	Ground (Analog)
23	VA	-	+5V power supply (Analog)
24	AINR-	I	R-ch analog (-) input
25	AINR+	I	R-ch analog (+) input
26	VCMR	O	R-ch common voltage output (+2.5V)
27	VRR-	O	R-ch reference voltage (-) output (+1.25V)
28	VRR+	O	R-ch reference voltage (+) output (+3.75V)

• IC601 Mode controller (MB90673PF-G-217-BND)

Pin No.	Pin Name	I/O	Function
1	–	–	Not used (Ground)
2	–	–	Not used (Ground)
3	–	–	Not used (Ground)
4	–	–	Not used (Ground)
5	–	–	Not used (Ground)
6	–	–	Not used (Ground)
7	–	–	Not used (Ground)
8	–	–	Not used (Ground)
9	–	–	Not used (Ground)
10	–	–	Not used (Ground)
11	VSS	–	Ground
12	–	–	Not used (Ground)
13	–	–	Not used (Ground)
14	–	–	Not used (Ground)
15	–	–	Not used (Ground)
16	–	–	Not used (Ground)
17	–	–	Not used (Ground)
18	–	–	Not used (Ground)
19	–	–	Not used (Ground)
20	–	–	Not used (Ground)
21	–	–	Not used (Ground)
22	–	–	Not used (Ground)
23	FL CLEAR	O	FL clear signal output to FL driver “H” : active
24	FL DATA	O	FL data output to FL diver
25	FL CLK	O	FL clock output to FL diver
26	FL LAT	O	FL latch output to FL driver “H” : active
27	SIRCS	I	Remote control signal input
28	VCC (A)	–	+5V power supply (Back-up)
29	+AVR	I	Reference voltage input (+) (+5V)
30	–AVR	I	Reference voltage input (–) (Ground)
31	GND (D)	–	Ground
32	AD KEY IN 1	I	Key input 1
33	AD KEY IN 2	I	Key input 2
34	VSS (D)	–	Ground
35	AD KEY IN 3	I	Key input 3 (Not used)
36	AD KEY IN 4	I	Key input 4 (Not used)
37	AD KEY IN 5	I	Key input 5 (Not used)
38	AD VERSION	–	Not used
39	–	–	Not used
40	–	–	Not used

Pin No.	Pin Name	I/O	Function
41	MODE0	I	Mode setting pin (Fixed at "H")
42	MODE1	I	Mode setting pin (Fixed at "H")
43	MODE2	I	Mode setting pin (Fixed at "L")
44	STANBY	I	Stanby signal input (Connected to VDD)
45	STOP	I	STOP signal input "L" : active
46	U-RESET	O	Reset output to system controller "L" : reset
47	U-SREQ	I	Slave data request signal input from system controller
48	U-MREQ	O	Master request signal output to system controller
49	U-DATA	O	Master data output to system controller
50	U-CLOCK	O	Master clock output to system controller
51	(GND)	–	Ground
52	–	–	Not used (Ground)
53	–	–	Not used (Ground)
54	(GND)	–	Ground
55	–	–	Not used (Ground)
56	–	–	Not used (Ground)
57	–	–	Not used (Ground)
58	–	–	Not used (Ground)
59	–	–	Not used (Ground)
60	–	–	Not used (Ground)
61	–	–	Not used (Ground)
62	XRESET	I	Reset signal input "L" : reset
63	VSS (D)	–	Ground
64	X0	O	Clock output (4MHz)
65	X1	I	Clock input (4MHz)
66	VCC (D)	–	+5V power supply (Back-up)
67	–	–	Not used (Ground)
68	–	–	Not used (Ground)
69	–	–	Not used (Ground)
70	–	–	Not used (Ground)
71	–	–	Not used (Ground)
72	–	–	Not used (Ground)
73	LED VOL	O	Volume LED drive signal output "H" : active
74	LED BASS B	O	Bass boost LED drive signal output "H" : active
75	–	–	Not used (Ground)
76	–	–	Not used (Ground)
77	–	–	Not used (Ground)
78	–	–	Not used (Ground)
79	–	–	Not used (Ground)
80	–	–	Not used (Ground)

5-2. MAIN BOARD SECTION

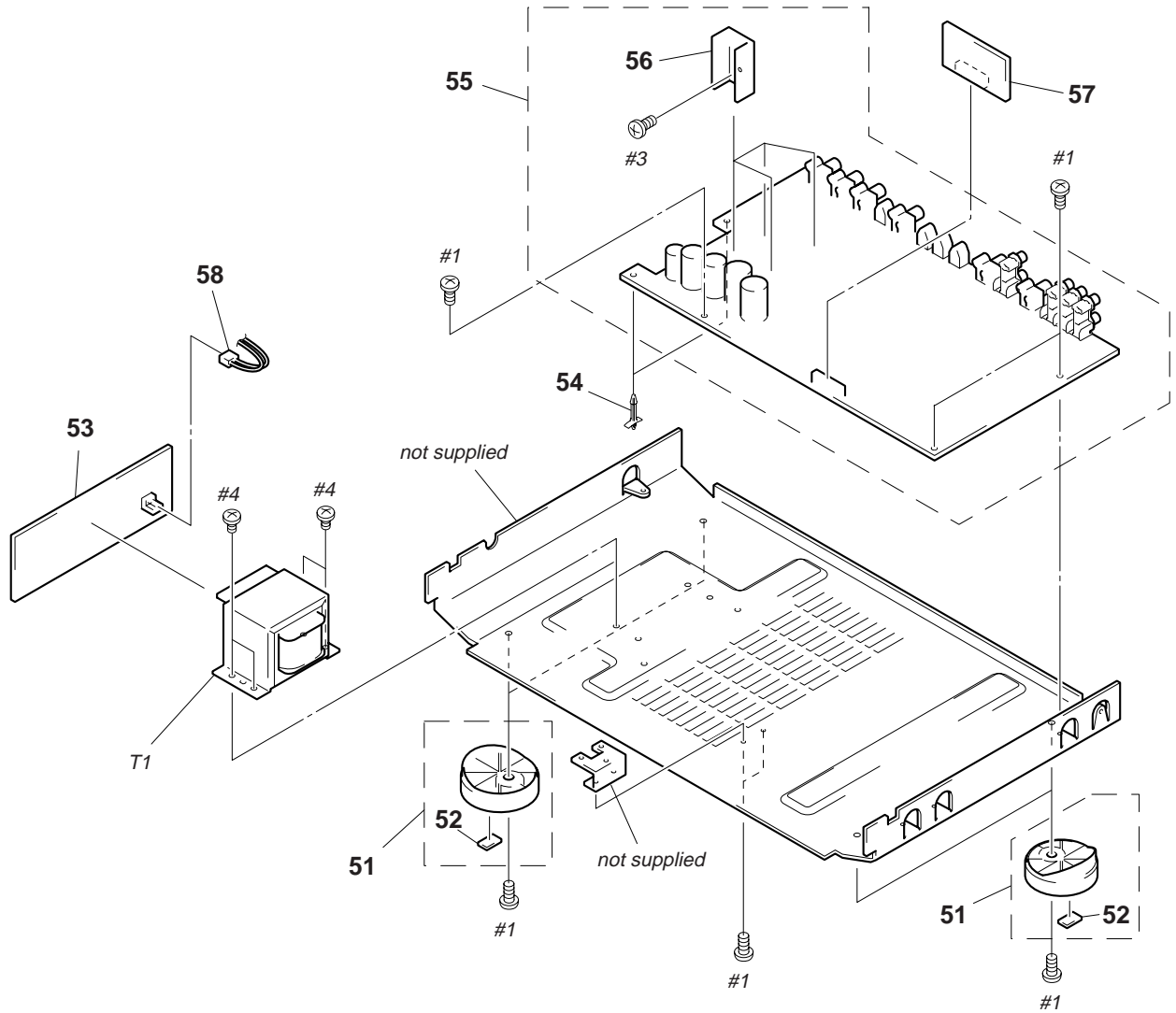

The components identified by mark \triangle or dotted line with mark \triangle are critical for safety. Replace only with part number specified.

Les composants identifiés par une marque \triangle sont critiques pour la sécurité. Ne les remplacer que par une pièce portant le numéro spécifié.

Ref. No.	Part No.	Description	Remark	Ref. No.	Part No.	Description	Remark
51	X-4947-389-1	FOOT ASSY (F50150S)(SILVER)...(BLACK) (AEP,UK,E,SP,AUS)		* 55	A-4403-083-A	MAIN BOARD, COMPLETE (AEP,UK,CH,AUS)	
51	X-4947-390-1	FOOT ASSY (F50150S)(BLACK)...(BLACK) (US,CND)		* 55	A-4403-087-A	MAIN BOARD, COMPLETE (E,SP)	
51	X-4949-003-1	FOOT ASSY (GOLD)...(GOLD)		* 56	4-880-403-11	HEAT SINK	
52	4-983-762-02	CUSHION		* 57	A-4403-394-A	PLL BOARD, COMPLETE (US,CND)	
* 53	1-666-567-11	TRANS BOARD		* 57	A-4403-395-A	PLL BOARD, COMPLETE (AEP,UK,E,SP,CH,AUS)	
* 54	4-924-098-01	HOLDER, PC BOARD		58	1-769-077-31	LEAD (WITH CONNECTOR)(2 CORE)	
* 55	A-4403-077-A	MAIN BOARD, COMPLETE (US,CND)		\triangle T1	1-431-453-11	TRANSFORMER, POWER (US,CND)	
				\triangle T1	1-431-455-11	TRANSFORMER, POWER (AEP,UK,E,SP,AUS,CH)	

SECTION 6 ELECTRICAL PARTS LIST

AC SW

DISPLAY

Note:

The components identified by mark Δ or dotted line with mark Δ are critical for safety. Replace only with part number specified.

Les composants identifiés par une marque Δ sont critiques pour la sécurité. Ne les remplacer que par une pièce portant le numéro spécifié.

When indicating parts by reference number, please include the board name.

- Due to standardization, replacements in the parts list may be different from the parts specified in the diagrams or the components used on the set.
- Items marked "*" are not stocked since they are seldom required for routine service. Some delay should be anticipated when ordering these items.
- RESISTORS
All resistors are in ohms
METAL: Metal-film resistor
METAL OXIDE: Metal Oxide-film resistor
F : nonflammable
- SEMICONDUCTORS
In each case, μ : μ , for example:
uA...: μ A..., uPA...: μ PA..., uPB...: μ PB...,
uPC...: μ PC..., uPD...: μ PD...
- CAPACITORS
uF : μ F
- COILS
uH : μ H
- Abbreviation
CND : Canadian model
SP : Singapore model
AUS : Australian model
CH : Chinese model

Ref. No.	Part No.	Description	Remark	Ref. No.	Part No.	Description	Remark
*	1-666-566-11	AC SW BOARD *****				< FLUORESCENT INDICATOR >	
		< CAPACITOR >		FL601	1-517-671-11	INDICATOR TUBE, FLUORESCENT	
Δ C802	1-115-383-51	CERAMIC 0.01uF 10% 125V				< IC >	
		< CONNECTOR >		IC601	8-759-476-32	IC MB90673PF-G-217-BND	
* CN803	1-565-792-11	PIN, CONNECTOR 2P		IC602	8-759-075-35	IC TD62C950RF	
		< SWITCH >		IC603	8-759-999-53	IC MSC1164GS-K	
Δ S801	1-572-267-51	SWITCH, PUSH (AC POWER)(1 KEY)(POWER)		IC604	8-759-962-08	IC BA6208	
		*****		IC605	8-759-459-84	IC NJL56H400	
*	A-4403-079-A	DISPLAY BOARD, COMPLETE *****		IC606	8-759-165-80	IC PST600C-T	
						< COIL >	
*	4-932-810-11	CUSHION (FL)		L601	1-410-521-11	INDUCTOR 100uH	
*	4-990-797-01	HOLDER (FL)				< TRANSISTOR >	
		< CAPACITOR >		Q601	8-729-119-76	TRANSISTOR 2SA1175-HFE	
C601	1-126-795-11	ELECT 10uF 20% 50V		Q602	8-729-661-95	TRANSISTOR RT1N241SK-TP	
C602	1-164-159-11	CERAMIC 0.1uF 50V		Q603	8-729-661-95	TRANSISTOR RT1N241SK-TP	
C603	1-104-905-11	CAPACITOR 0.22F 5.5V		Q604	8-729-661-95	TRANSISTOR RT1N241SK-TP	
C604	1-164-159-11	CERAMIC 0.1uF 50V				< RESISTOR >	
C605	1-164-159-11	CERAMIC 0.1uF 50V		R604	1-249-425-11	CARBON 4.7K 5% 1/4W F	
C606	1-164-159-11	CERAMIC 0.1uF 50V		R605	1-249-429-11	CARBON 10K 5% 1/4W	
C607	1-126-786-11	ELECT 47uF 20% 16V		R606	1-249-419-11	CARBON 1.5K 5% 1/4W F	
C608	1-126-786-11	ELECT 47uF 20% 16V		R607	1-249-429-11	CARBON 10K 5% 1/4W	
C609	1-164-159-11	CERAMIC 0.1uF 50V		R608	1-249-429-11	CARBON 10K 5% 1/4W	
C610	1-162-306-11	CERAMIC 10000PF 20% 16V		R609	1-249-411-11	CARBON 330 5% 1/4W	
C611	1-162-306-11	CERAMIC 10000PF 20% 16V		R610	1-249-433-11	CARBON 22K 5% 1/4W	
C612	1-124-455-00	ELECT 100uF 20% 16V		R611	1-249-437-11	CARBON 47K 5% 1/4W	
C613	1-162-306-11	CERAMIC 10000PF 20% 16V		R612	1-249-393-11	CARBON 10 5% 1/4W F	
C614	1-162-306-11	CERAMIC 10000PF 20% 16V		R613	1-249-417-11	CARBON 1K 5% 1/4W F	
C615	1-162-306-11	CERAMIC 10000PF 20% 16V		R614	1-249-417-11	CARBON 1K 5% 1/4W F	
		< CONNECTOR >		R615	1-249-417-11	CARBON 1K 5% 1/4W F	
* CN601	1-568-854-11	SOCKET, CONNECTOR 11P		R616	1-249-417-11	CARBON 1K 5% 1/4W F	
		< DIODE >		R617	1-249-429-11	CARBON 10K 5% 1/4W	
D601	8-719-987-63	DIODE 1N4148M		R618	1-249-425-11	CARBON 4.7K 5% 1/4W F	
D602	8-719-200-82	DIODE 11ES2		R619	1-249-425-11	CARBON 4.7K 5% 1/4W F	
D603	8-719-313-45	DIODE SEL6810A-TH10 (BASS BOOST)		R620	1-249-429-11	CARBON 10K 5% 1/4W	
				R621	1-249-429-11	CARBON 10K 5% 1/4W	
				R660	1-249-411-11	CARBON 330 5% 1/4W	
				R661	1-249-413-11	CARBON 470 5% 1/4W F	
				R662	1-249-415-11	CARBON 680 5% 1/4W F	
				R663	1-249-417-11	CARBON 1K 5% 1/4W F	

Ref. No.	Part No.	Description	Remark	Ref. No.	Part No.	Description	Remark
R664	1-249-419-11	CARBON	1.5K 5% 1/4W F	C121	1-164-232-11	CERAMIC CHIP	0.01uF 50V
R665	1-249-421-11	CARBON	2.2K 5% 1/4W F	C122	1-165-319-11	CERAMIC CHIP	0.1uF 50V
R666	1-249-411-11	CARBON	330 5% 1/4W	C123	1-165-319-11	CERAMIC CHIP	0.1uF 50V
R667	1-249-413-11	CARBON	470 5% 1/4W F	C124	1-136-921-11	FILM	1uF 5% 50V
R668	1-249-415-11	CARBON	680 5% 1/4W F	C125	1-136-921-11	FILM	1uF 5% 50V
R669	1-249-417-11	CARBON	1K 5% 1/4W F	C126	1-165-319-11	CERAMIC CHIP	0.1uF 50V
R670	1-249-419-11	CARBON	1.5K 5% 1/4W F	C127	1-165-319-11	CERAMIC CHIP	0.1uF 50V
< SWITCH >				C128	1-164-232-11	CERAMIC CHIP	0.01uF 50V
S601	1-554-303-21	SWITCH, TACTILE (DPC MODE)		C129	1-126-933-11	ELECT	100uF 20% 16V
S602	1-554-303-21	SWITCH, TACTILE (<)		C130	1-165-319-11	CERAMIC CHIP	0.1uF 50V
S603	1-554-303-21	SWITCH, TACTILE (v)		C131	1-165-319-11	CERAMIC CHIP	0.1uF 50V
S604	1-554-303-21	SWITCH, TACTILE (>)		C132	1-126-967-11	ELECT	47uF 20% 50V
S605	1-554-303-21	SWITCH, TACTILE (^)		C133	1-165-319-11	CERAMIC CHIP	0.1uF 50V
S606	1-554-303-21	SWITCH, TACTILE (DIGITAL 1)		C134	1-126-933-11	ELECT	100uF 20% 10V
S607	1-554-303-21	SWITCH, TACTILE (DIGITAL 2)		C135	1-164-232-11	CERAMIC CHIP	0.01uF 50V
S608	1-554-303-21	SWITCH, TACTILE (DIGITAL 3)		C136	1-163-085-00	CERAMIC CHIP	2PF 50V
S609	1-554-303-21	SWITCH, TACTILE (ANALOG)		C137	1-163-099-00	CERAMIC CHIP	18PF 5% 50V
S610	1-554-303-21	SWITCH, TACTILE (SOUND FIELD ON/OFF)		C138	1-165-319-11	CERAMIC CHIP	0.1uF 50V
S611	1-554-303-21	SWITCH, TACTILE (MODE)		C139	1-165-319-11	CERAMIC CHIP	0.1uF 50V
S612	1-554-303-21	SWITCH, TACTILE (GENRE)		C140	1-165-319-11	CERAMIC CHIP	0.1uF 50V
S613	1-554-303-21	SWITCH, TACTILE (BASS BOOST)		C141	1-165-319-11	CERAMIC CHIP	0.1uF 50V
< VIBRATOR >				C142	1-165-319-11	CERAMIC CHIP	0.1uF 50V
X601	1-567-819-11	VIBRATOR, CERAMIC (4MHz)		C143	1-165-319-11	CERAMIC CHIP	0.1uF 50V
*****				C144	1-165-319-11	CERAMIC CHIP	0.1uF 50V
*	A-4403-083-A	MAIN BOARD, COMPLETE (AEP,UK,CH,AUS)	*****	C145	1-165-319-11	CERAMIC CHIP	0.1uF 50V
*	A-4403-077-A	MAIN BOARD, COMPLETE (US,CND)	*****	C146	1-165-319-11	CERAMIC CHIP	0.1uF 50V
*	A-4403-087-A	MAIN BOARD, COMPLETE (E,SP)	*****	C147	1-165-319-11	CERAMIC CHIP	0.1uF 50V
*	4-880-403-11	HEAT SINK		C148	1-165-319-11	CERAMIC CHIP	0.1uF 50V
	7-685-872-09	SCREW +BVTT 3X8 (S)		C149	1-165-319-11	CERAMIC CHIP	0.1uF 50V
< CAPACITOR >				C150	1-165-319-11	CERAMIC CHIP	0.1uF 50V
C101	1-165-319-11	CERAMIC CHIP	0.1uF 50V	C151	1-165-319-11	CERAMIC CHIP	0.1uF 50V
C102	1-165-319-11	CERAMIC CHIP	0.1uF 50V	C152	1-163-275-11	CERAMIC CHIP	0.001uF 5% 50V
C103	1-165-319-11	CERAMIC CHIP	0.1uF 50V	C153	1-165-319-11	CERAMIC CHIP	0.1uF 50V
C104	1-165-319-11	CERAMIC CHIP	0.1uF 50V	C154	1-126-965-11	ELECT	22uF 20% 50V
C105	1-165-319-11	CERAMIC CHIP	0.1uF 50V	C155	1-164-232-11	CERAMIC CHIP	0.01uF 50V
C106	1-165-319-11	CERAMIC CHIP	0.1uF 50V	C156	1-165-319-11	CERAMIC CHIP	0.1uF 50V
C107	1-165-319-11	CERAMIC CHIP	0.1uF 50V	C157	1-163-093-00	CERAMIC CHIP	10PF 5% 50V
C108	1-163-275-11	CERAMIC CHIP	0.001uF 5% 50V	C158	1-165-319-11	CERAMIC CHIP	0.1uF 50V
C109	1-163-251-11	CERAMIC CHIP	100PF 5% 50V	C159	1-165-319-11	CERAMIC CHIP	0.1uF 50V
C110	1-163-023-00	CERAMIC CHIP	0.015uF 5% 50V	C160	1-163-275-11	CERAMIC CHIP	0.001uF 5% 50V
C111	1-165-319-11	CERAMIC CHIP	0.1uF 50V	C161	1-165-319-11	CERAMIC CHIP	0.1uF 50V
C112	1-165-319-11	CERAMIC CHIP	0.1uF 50V	C162	1-165-319-11	CERAMIC CHIP	0.1uF 50V
C113	1-163-235-11	CERAMIC CHIP	22PF 5% 50V	C163	1-126-965-11	ELECT	22uF 20% 50V
C114	1-163-235-11	CERAMIC CHIP	22PF 5% 50V	C164	1-164-232-11	CERAMIC CHIP	0.01uF 50V
C115	1-165-319-11	CERAMIC CHIP	0.1uF 50V	C165	1-165-319-11	CERAMIC CHIP	0.1uF 50V
C116	1-163-037-11	CERAMIC CHIP	0.022uF 10% 25V	C166	1-163-093-00	CERAMIC CHIP	10PF 5% 50V
C117	1-165-319-11	CERAMIC CHIP	0.1uF 50V	C167	1-165-319-11	CERAMIC CHIP	0.1uF 50V
C118	1-165-319-11	CERAMIC CHIP	0.1uF 50V	C168	1-165-319-11	CERAMIC CHIP	0.1uF 50V
C119	1-163-248-11	CERAMIC CHIP	75PF 5% 50V	C169	1-165-319-11	CERAMIC CHIP	0.1uF 50V
C120	1-163-275-11	CERAMIC CHIP	0.001uF 5% 50V	C170	1-165-319-11	CERAMIC CHIP	0.1uF 50V
				C171	1-165-319-11	CERAMIC CHIP	0.1uF 50V
				C172	1-165-319-11	CERAMIC CHIP	0.1uF 50V
				C173	1-165-319-11	CERAMIC CHIP	0.1uF 50V
				C174	1-165-319-11	CERAMIC CHIP	0.1uF 50V
				C175	1-163-275-11	CERAMIC CHIP	0.001uF 5% 50V
				C177	1-165-319-11	CERAMIC CHIP	0.1uF 50V
				C178	1-165-319-11	CERAMIC CHIP	0.1uF 50V
				C179	1-165-319-11	CERAMIC CHIP	0.1uF 50V
				C180	1-165-319-11	CERAMIC CHIP	0.1uF 50V

MAIN

Ref. No.	Part No.	Description			Remark	Ref. No.	Part No.	Description			Remark
C181	1-165-319-11	CERAMIC CHIP	0.1uF		50V	C328	1-126-964-11	ELECT	10uF	20%	50V
C182	1-163-243-11	CERAMIC CHIP	47PF	5%	50V	C329	1-163-243-11	CERAMIC CHIP	47PF	5%	50V
C189	1-165-319-11	CERAMIC CHIP	0.1uF		50V	C330	1-126-963-11	ELECT	4.7uF	20%	50V
C201	1-126-964-11	ELECT	10uF	20%	50V	C331	1-165-319-11	CERAMIC CHIP	0.1uF		50V
C202	1-126-964-11	ELECT	10uF	20%	50V	C335	1-126-964-11	ELECT	10uF	20%	50V
C203	1-110-341-11	MYLAR	330PF	5%	50V	C336	1-126-964-11	ELECT	10uF	20%	50V
C204	1-110-341-11	MYLAR	330PF	5%	50V	C340	1-165-319-11	CERAMIC CHIP	0.1uF		50V
C205	1-165-319-11	CERAMIC CHIP	0.1uF		50V	C360	1-130-467-00	MYLAR	470PF	5%	50V
C206	1-126-964-11	ELECT	10uF	20%	50V	C361	1-110-339-11	MYLAR	220PF	5%	50V
C207	1-126-964-11	ELECT	10uF	20%	50V	C363	1-110-339-11	MYLAR	220PF	5%	50V
C208	1-126-964-11	ELECT	10uF	20%	50V	C364	1-165-319-11	CERAMIC CHIP	0.1uF		50V
C209	1-164-489-11	CERAMIC CHIP	0.22uF	10%	16V	C365	1-110-339-11	MYLAR	220PF	5%	50V
C210	1-164-489-11	CERAMIC CHIP	0.22uF	10%	16V	C366	1-110-339-11	MYLAR	220PF	5%	50V
C211	1-106-351-00	MYLAR	2200PF	5%	200V	C367	1-165-319-11	CERAMIC CHIP	0.1uF		50V
C231	1-165-319-11	CERAMIC CHIP	0.1uF		50V	C368	1-130-477-00	MYLAR	0.0033uF	5%	50V
C232	1-165-319-11	CERAMIC CHIP	0.1uF		50V	C369	1-165-319-11	CERAMIC CHIP	0.1uF		50V
C233	1-165-319-11	CERAMIC CHIP	0.1uF		50V	C370	1-130-469-00	MYLAR	680PF	5%	50V
C234	1-165-319-11	CERAMIC CHIP	0.1uF		50V	C371	1-126-965-11	ELECT	22uF	20%	50V
C235	1-104-665-11	ELECT	100uF	20%	25V	C372	1-126-964-11	ELECT	10uF	20%	50V
C236	1-104-665-11	ELECT	100uF	20%	25V	C373	1-126-964-11	ELECT	10uF	20%	50V
C237	1-126-967-11	ELECT	47uF	20%	50V	C376	1-163-093-00	CERAMIC CHIP	10PF	5%	50V
C238	1-165-319-11	CERAMIC CHIP	0.1uF		50V	C378	1-126-964-11	ELECT	10uF	20%	50V
C239	1-164-232-11	CERAMIC CHIP	0.01uF		50V	C379	1-163-243-11	CERAMIC CHIP	47PF	5%	50V
C240	1-165-319-11	CERAMIC CHIP	0.1uF		50V	C380	1-126-963-11	ELECT	4.7uF	20%	50V
C251	1-126-964-11	ELECT	10uF	20%	50V	C381	1-165-319-11	CERAMIC CHIP	0.1uF		50V
C252	1-126-964-11	ELECT	10uF	20%	50V	C501	1-126-966-11	ELECT	33uF	20%	50V
C253	1-110-341-11	MYLAR	330PF	5%	50V	C502	1-126-966-11	ELECT	33uF	20%	50V
C254	1-110-341-11	MYLAR	330PF	5%	50V	C503	1-126-966-11	ELECT	33uF	20%	50V
C255	1-165-319-11	CERAMIC CHIP	0.1uF		50V	C504	1-126-966-11	ELECT	33uF	20%	50V
C256	1-126-964-11	ELECT	10uF	20%	50V	C505	1-126-966-11	ELECT	33uF	20%	50V
C257	1-126-964-11	ELECT	10uF	20%	50V	C506	1-165-319-11	CERAMIC CHIP	0.1uF		50V
C258	1-126-964-11	ELECT	10uF	20%	50V	C507	1-165-319-11	CERAMIC CHIP	0.1uF		50V
C259	1-164-489-11	CERAMIC CHIP	0.22uF	10%	16V	C508	1-163-243-11	CERAMIC CHIP	47PF	5%	50V
C260	1-164-489-11	CERAMIC CHIP	0.22uF	10%	16V	C901	1-128-547-11	ELECT	6800uF	20%	16V
C261	1-106-351-00	MYLAR	2200PF	5%	200V	C902	1-126-953-11	ELECT	2200uF	20%	35V
C301	1-165-319-11	CERAMIC CHIP	0.1uF		50V	C903	1-126-953-11	ELECT	2200uF	20%	35V
C302	1-165-319-11	CERAMIC CHIP	0.1uF		50V	C904	1-128-555-91	ELECT	470uF	20%	63V
C303	1-165-319-11	CERAMIC CHIP	0.1uF		50V	C905	1-164-232-11	CERAMIC CHIP	0.01uF		50V
C304	1-165-319-11	CERAMIC CHIP	0.1uF		50V	C906	1-164-232-11	CERAMIC CHIP	0.01uF		50V
C305	1-165-319-11	CERAMIC CHIP	0.1uF		50V	C907	1-164-232-11	CERAMIC CHIP	0.01uF		50V
C306	1-165-319-11	CERAMIC CHIP	0.1uF		50V	C908	1-126-967-11	ELECT	47uF	20%	50V
C307	1-163-251-11	CERAMIC CHIP	100PF	5%	50V	C909	1-126-964-11	ELECT	10uF	20%	50V
C308	1-163-251-11	CERAMIC CHIP	100PF	5%	50V	C910	1-126-964-11	ELECT	10uF	20%	50V
C310	1-130-467-00	MYLAR	470PF	5%	50V	C911	1-126-964-11	ELECT	10uF	20%	50V
C311	1-110-339-11	MYLAR	220PF	5%	50V	C912	1-126-964-11	ELECT	10uF	20%	50V
C312	1-165-319-11	CERAMIC CHIP	0.1uF		50V	C913	1-164-232-11	CERAMIC CHIP	0.01uF		50V
C313	1-110-339-11	MYLAR	220PF	5%	50V	C914	1-164-232-11	CERAMIC CHIP	0.01uF		50V
C314	1-165-319-11	CERAMIC CHIP	0.1uF		50V	C915	1-164-232-11	CERAMIC CHIP	0.01uF		50V
C315	1-110-339-11	MYLAR	220PF	5%	50V	C916	1-128-547-11	ELECT	6800uF	20%	16V
C316	1-110-339-11	MYLAR	220PF	5%	50V	C917	1-104-661-91	ELECT	330uF	20%	16V
C317	1-165-319-11	CERAMIC CHIP	0.1uF		50V	C918	1-104-661-91	ELECT	330uF	20%	16V
C318	1-130-477-00	MYLAR	0.0033uF	5%	50V	C1301	1-165-319-11	CERAMIC CHIP	0.1uF		50V
C319	1-165-319-11	CERAMIC CHIP	0.1uF		50V	C1302	1-165-319-11	CERAMIC CHIP	0.1uF		50V
C320	1-130-469-00	MYLAR	680PF	5%	50V	C1303	1-165-319-11	CERAMIC CHIP	0.1uF		50V
C321	1-126-965-11	ELECT	22uF	20%	50V	C1304	1-165-319-11	CERAMIC CHIP	0.1uF		50V
C322	1-126-964-11	ELECT	10uF	20%	50V	C1305	1-165-319-11	CERAMIC CHIP	0.1uF		50V
C323	1-126-964-11	ELECT	10uF	20%	50V	C1306	1-165-319-11	CERAMIC CHIP	0.1uF		50V
C326	1-163-093-00	CERAMIC CHIP	10PF	5%	50V	C1307	1-163-251-11	CERAMIC CHIP	100PF	5%	50V

Ref. No.	Part No.	Description	Remark	Ref. No.	Part No.	Description	Remark
C1308	1-163-251-11	CERAMIC CHIP	100PF 5% 50V	C2321	1-126-965-11	ELECT 22uF 20% 50V	
C1310	1-130-467-00	MYLAR	470PF 5% 50V	C2322	1-126-964-11	ELECT 10uF 20% 50V	
C1311	1-110-339-11	MYLAR	220PF 5% 50V	C2323	1-126-964-11	ELECT 10uF 20% 50V	
C1312	1-165-319-11	CERAMIC CHIP	0.1uF 50V	C2328	1-126-964-11	ELECT 10uF 20% 50V	
C1313	1-110-339-11	MYLAR	220PF 5% 50V	C2329	1-163-243-11	CERAMIC CHIP 47PF 5% 50V	
C1314	1-165-319-11	CERAMIC CHIP	0.1uF 50V	C2330	1-126-963-11	ELECT 4.7uF 20% 50V	
C1315	1-110-339-11	MYLAR	220PF 5% 50V	C2331	1-165-319-11	CERAMIC CHIP 0.1uF 50V	
C1316	1-110-339-11	MYLAR	220PF 5% 50V	C2335	1-126-964-11	ELECT 10uF 20% 50V	
C1317	1-165-319-11	CERAMIC CHIP	0.1uF 50V	C2336	1-126-964-11	ELECT 10uF 20% 50V	
C1318	1-130-477-00	MYLAR	0.0033uF 5% 50V	C2360	1-130-467-00	MYLAR 470PF 5% 50V	
C1319	1-165-319-11	CERAMIC CHIP	0.1uF 50V	C2361	1-110-339-11	MYLAR 220PF 5% 50V	
C1320	1-130-469-00	MYLAR	680PF 5% 50V	C2362	1-165-319-11	CERAMIC CHIP 0.1uF 50V	
C1321	1-126-965-11	ELECT	22uF 20% 50V	C2363	1-110-339-11	MYLAR 220PF 5% 50V	
C1322	1-126-964-11	ELECT	10uF 20% 50V	C2364	1-165-319-11	CERAMIC CHIP 0.1uF 50V	
C1323	1-126-964-11	ELECT	10uF 20% 50V	C2365	1-110-339-11	MYLAR 220PF 5% 50V	
C1328	1-126-964-11	ELECT	10uF 20% 50V	C2366	1-110-339-11	MYLAR 220PF 5% 50V	
C1329	1-163-243-11	CERAMIC CHIP	47PF 5% 50V	C2367	1-165-319-11	CERAMIC CHIP 0.1uF 50V	
C1330	1-126-963-11	ELECT	4.7uF 20% 50V	C2368	1-130-477-00	MYLAR 0.0033uF 5% 50V	
C1331	1-165-319-11	CERAMIC CHIP	0.1uF 50V	C2369	1-165-319-11	CERAMIC CHIP 0.1uF 50V	
C1335	1-126-964-11	ELECT	10uF 20% 50V	C2370	1-130-469-00	MYLAR 680PF 5% 50V	
C1336	1-126-964-11	ELECT	10uF 20% 50V	C2371	1-126-965-11	ELECT 22uF 20% 50V	
C1360	1-130-467-00	MYLAR	470PF 5% 50V	C2372	1-126-964-11	ELECT 10uF 20% 50V	
C1361	1-110-339-11	MYLAR	220PF 5% 50V	C2373	1-126-964-11	ELECT 10uF 20% 50V	
C1362	1-165-319-11	CERAMIC CHIP	0.1uF 50V	C2378	1-126-964-11	ELECT 10uF 20% 50V	
C1363	1-110-339-11	MYLAR	220PF 5% 50V	C2379	1-163-243-11	CERAMIC CHIP 47PF 5% 50V	
C1364	1-165-319-11	CERAMIC CHIP	0.1uF 50V	C2380	1-126-963-11	ELECT 4.7uF 20% 50V	
C1365	1-110-339-11	MYLAR	220PF 5% 50V	C2381	1-165-319-11	CERAMIC CHIP 0.1uF 50V	
C1366	1-110-339-11	MYLAR	220PF 5% 50V			< CONNECTOR >	
C1367	1-165-319-11	CERAMIC CHIP	0.1uF 50V	* CN101	1-568-830-11	SOCKET, CONNECTOR 11P	
C1368	1-130-477-00	MYLAR	0.0033uF 5% 50V	CN102	1-568-802-11	SOCKET, CONNECTOR 19P	
C1369	1-165-319-11	CERAMIC CHIP	0.1uF 50V	CN103	1-695-090-11	PIN, CONNECTOR (PC BOARD) 13P	
C1370	1-130-469-00	MYLAR	680PF 5% 50V	CN902	1-691-772-11	PLUG (MICRO CONNECTOR) 10P	
C1371	1-126-965-11	ELECT	22uF 20% 50V			< DIODE >	
C1372	1-126-964-11	ELECT	10uF 20% 50V	D101	8-719-061-62	DIODE KV1851	
C1373	1-126-964-11	ELECT	10uF 20% 50V	D102	8-719-801-78	DIODE 1SS184	
C1378	1-126-964-11	ELECT	10uF 20% 50V	D103	8-719-801-78	DIODE 1SS184	
C1379	1-163-243-11	CERAMIC CHIP	47PF 5% 50V	D104	8-719-801-78	DIODE 1SS184	
C1380	1-126-963-11	ELECT	4.7uF 20% 50V	D105	8-719-801-78	DIODE 1SS184	
C1381	1-165-319-11	CERAMIC CHIP	0.1uF 50V	D106	8-719-801-78	DIODE 1SS184	
C2301	1-165-319-11	CERAMIC CHIP	0.1uF 50V	D107	8-719-801-78	DIODE 1SS184	
C2302	1-165-319-11	CERAMIC CHIP	0.1uF 50V	D108	8-719-210-33	DIODE EC10DS2	
C2303	1-165-319-11	CERAMIC CHIP	0.1uF 50V	D109	8-719-210-33	DIODE EC10DS2	
C2304	1-165-319-11	CERAMIC CHIP	0.1uF 50V	D301	8-719-801-78	DIODE 1SS184	
C2305	1-165-319-11	CERAMIC CHIP	0.1uF 50V	D902	8-719-025-33	DIODE 02CZ6.2-TE85L	
C2306	1-165-319-11	CERAMIC CHIP	0.1uF 50V	D905	8-719-028-23	DIODE D3SBA20-4101	
C2307	1-163-251-11	CERAMIC CHIP	100PF 5% 50V	D913	8-719-025-59	DIODE 02CZ39-TE85L	
C2308	1-163-251-11	CERAMIC CHIP	100PF 5% 50V	D914	8-719-025-34	DIODE 02CZ6.8-TE85L	
C2310	1-130-467-00	MYLAR	470PF 5% 50V	D915	8-719-801-78	DIODE 1SS184	
C2311	1-110-339-11	MYLAR	220PF 5% 50V	D1301	8-719-801-78	DIODE 1SS184	
C2312	1-165-319-11	CERAMIC CHIP	0.1uF 50V	D2301	8-719-801-78	DIODE 1SS184	
C2313	1-110-339-11	MYLAR	220PF 5% 50V			< FERRITE BEAD >	
C2314	1-165-319-11	CERAMIC CHIP	0.1uF 50V	FB301	1-410-397-21	FERRITE BEAD INDUCTOR	
C2315	1-110-339-11	MYLAR	220PF 5% 50V	FB1301	1-410-397-21	FERRITE BEAD INDUCTOR	
C2316	1-110-339-11	MYLAR	220PF 5% 50V	FB2301	1-410-397-21	FERRITE BEAD INDUCTOR	
C2317	1-165-319-11	CERAMIC CHIP	0.1uF 50V				
C2318	1-130-477-00	MYLAR	0.0033uF 5% 50V				
C2319	1-165-319-11	CERAMIC CHIP	0.1uF 50V				
C2320	1-130-469-00	MYLAR	680PF 5% 50V				

MAIN

Ref. No.	Part No.	Description	Remark	Ref. No.	Part No.	Description	Remark
		< FLUORESCENT INDICATOR >					
FL101	1-233-866-11	FILTER, BAND PASS		IC2306	8-759-636-55	IC M5218AFP	
		< IC >		IC2352	8-759-636-55	IC M5218AFP	
IC101	8-749-923-05	IC TORX178 (DIGITAL 1 OPTICAL IN)		IC2353	8-759-636-55	IC M5218AFP	
IC102	8-749-923-05	IC TORX178 (DIGITAL 2 OPTICAL IN)				< JACK >	
IC103	8-749-923-05	IC TORX178 (DIGITAL 3 OPTICAL IN)		J101	1-779-382-11	JACK, PIN 1P (DIGITAL 1 COAX IN)	
IC104	8-749-923-04	IC TOTX178 (DIGITAL 3 OPTICAL OUT)		J102	1-779-700-11	JACK, PIN 1P (DIGITAL 1 AC-3 RF)	
IC105	8-759-242-70	IC TC7WU04F		J103	1-774-227-11	JACK, PIN 1P (DIGITAL 1 VIDEO IN)	
				J104	1-774-227-11	JACK, PIN 1P (DIGITAL 2 VIDEO IN)	
IC106	8-759-236-19	IC TC74HC151AF(EL)		J105	1-774-227-11	JACK, PIN 1P (ANALOG VIDEO IN)	
IC107	8-759-326-72	IC CXD8521M					
IC108	8-759-232-65	IC TC74HC157AF		J106	1-770-719-11	JACK, PIN 2P (ANALOG IN L R)	
IC109	8-759-233-64	IC TC74HCU04AF		J107	1-774-227-11	JACK, PIN 1P (MONITOR OUT)	
IC110	8-759-262-03	IC MC14577CF		J108	1-779-685-11	JACK, PIN 6P (OUTPUT CENTER WOOFER REAR L R FRONT L R)	
						< JUMPER >	
IC111	8-759-636-55	IC M5218AFP		JR109	1-216-295-91	CONDUCTOR, CHIP	
IC112	8-759-045-17	IC NJM79L05UA				< COIL >	
IC113	8-759-441-94	IC IDT71256SA20Y-TL		L102	1-216-296-91	CONDUCTOR, CHIP (3216)	
IC114	8-759-463-68	IC SN-PM4007A		L103	1-216-296-91	CONDUCTOR, CHIP (3216)	
IC115	8-759-237-43	IC TC74HC393AF(EL)		L104	1-410-391-11	INDUCTOR CHIP 68uH	
						< TRANSISTOR >	
IC116	8-759-242-70	IC TC7WU04F		Q101	8-729-230-49	TRANSISTOR 2SC2712-YG	
IC117	8-759-242-70	IC TC7WU04F		Q102	8-729-230-49	TRANSISTOR 2SC2712-YG	
IC118	8-759-446-37	IC DSP56009FJ88F		Q103	8-729-216-22	TRANSISTOR 2SA1162-G	
IC119	8-759-446-40	IC SSP424023FJ88		Q104	8-729-230-49	TRANSISTOR 2SC2712-YG	
IC120	8-759-463-69	IC IDT71024S20TY-TL		Q105	8-729-230-49	TRANSISTOR 2SC2712-YG	
				Q106	8-729-216-22	TRANSISTOR 2SA1162-G	
IC150	8-759-476-33	IC MB90641APF-G-102-BND		Q107	8-729-230-49	TRANSISTOR 2SC2712-YG	
IC201	8-759-636-55	IC M5218AFP		Q108	8-729-038-23	TRANSISTOR RT1N141C-TP-1	
IC202	8-759-636-55	IC M5218AFP		Q113	8-729-216-22	TRANSISTOR 2SA1162-G	
IC203	8-759-463-77	IC CXD8681M-TP		Q117	8-729-038-23	TRANSISTOR RT1N141C-TP-1	
IC204	8-759-604-35	IC M5F78M05L		Q301	8-729-107-46	TRANSISTOR 2SC3624A-L15	
				Q302	8-729-107-46	TRANSISTOR 2SC3624A-L15	
IC205	8-759-045-17	IC NJM79L05UA		Q306	8-729-230-49	TRANSISTOR 2SC2712-YG	
IC252	8-759-636-55	IC M5218AFP		Q351	8-729-107-46	TRANSISTOR 2SC3624A-L15	
IC301	8-759-370-62	IC CXD8505BQ		Q352	8-729-107-46	TRANSISTOR 2SC3624A-L15	
IC302	8-759-636-55	IC M5218AFP		Q901	8-729-209-15	TRANSISTOR 2SD2012	
IC303	8-759-636-55	IC M5218AFP		Q902	8-729-209-15	TRANSISTOR 2SD2012	
				Q903	8-729-230-49	TRANSISTOR 2SC2712-YG	
IC304	8-759-636-55	IC M5218AFP		Q1301	8-729-107-46	TRANSISTOR 2SC3624A-L15	
IC305	8-759-463-70	IC LC7535M		Q1302	8-729-107-46	TRANSISTOR 2SC3624A-L15	
IC306	8-759-636-55	IC M5218AFP		Q1306	8-729-230-49	TRANSISTOR 2SC2712-YG	
IC352	8-759-636-55	IC M5218AFP		Q1351	8-729-107-46	TRANSISTOR 2SC3624A-L15	
IC353	8-759-636-55	IC M5218AFP		Q1352	8-729-107-46	TRANSISTOR 2SC3624A-L15	
				Q2301	8-729-107-46	TRANSISTOR 2SC3624A-L15	
IC501	8-759-474-37	IC NJM2279M-TE2		Q2302	8-729-107-46	TRANSISTOR 2SC3624A-L15	
IC702	8-759-237-43	IC TC74HC393AF(EL)		Q2306	8-729-230-49	TRANSISTOR 2SC2712-YG	
IC703	8-759-233-64	IC TC74HCU04AF		Q2351	8-729-107-46	TRANSISTOR 2SC3624A-L15	
IC901	8-759-231-53	IC TA7805S		Q2352	8-729-107-46	TRANSISTOR 2SC3624A-L15	
IC902	8-759-231-58	IC TA7812S				< RESISTOR >	
				R101	1-216-022-00	METAL CHIP 75 5% 1/10W	
IC903	8-759-245-86	IC TA7912S		R102	1-216-049-91	METAL GLAZE 1K 5% 1/10W	
IC1301	8-759-370-62	IC CXD8505BQ		R103	1-216-073-00	METAL CHIP 10K 5% 1/10W	
IC1302	8-759-636-55	IC M5218AFP		R104	1-216-025-91	METAL GLAZE 100 5% 1/10W	
IC1303	8-759-636-55	IC M5218AFP					
IC1304	8-759-636-55	IC M5218AFP					
IC1305	8-759-463-70	IC LC7535M					
IC1306	8-759-636-55	IC M5218AFP					
IC1352	8-759-636-55	IC M5218AFP					
IC1353	8-759-636-55	IC M5218AFP					
IC2301	8-759-370-62	IC CXD8505BQ					
IC2302	8-759-636-55	IC M5218AFP					
IC2303	8-759-636-55	IC M5218AFP					
IC2304	8-759-636-55	IC M5218AFP					
IC2305	8-759-463-70	IC LC7535M					

Ref. No.	Part No.	Description			Remark	Ref. No.	Part No.	Description			Remark
R105	1-216-022-00	METAL CHIP	75	5%	1/10W	R163	1-216-049-91	METAL GLAZE 1K	5%		1/10W
R106	1-216-022-00	METAL CHIP	75	5%	1/10W	R167	1-216-295-91	CONDUCTOR, CHIP (2012)			
R107	1-216-022-00	METAL CHIP	75	5%	1/10W	R168	1-216-295-91	CONDUCTOR, CHIP (2012)			
R108	1-216-022-00	METAL CHIP	75	5%	1/10W						
R109	1-216-029-00	METAL CHIP	150	5%	1/10W	R169	1-216-295-91	CONDUCTOR, CHIP (2012)			
R110	1-216-065-00	METAL CHIP	4.7K	5%	1/10W	R170	1-216-295-91	CONDUCTOR, CHIP (2012)			
						R171	1-216-295-91	CONDUCTOR, CHIP (2012)			
R111	1-216-081-00	METAL CHIP	22K	5%	1/10W	R172	1-216-295-91	CONDUCTOR, CHIP (2012)			
R112	1-216-022-00	METAL CHIP	75	5%	1/10W	R173	1-216-073-00	METAL CHIP 10K	5%		1/10W
R113	1-216-065-00	METAL CHIP	4.7K	5%	1/10W						
R114	1-216-109-00	METAL CHIP	330K	5%	1/10W	R174	1-216-295-91	CONDUCTOR, CHIP (2012)			
R115	1-216-121-91	METAL GLAZE	1M	5%	1/10W	R175	1-216-295-91	CONDUCTOR, CHIP (2012)			
						R176	1-216-295-91	CONDUCTOR, CHIP (2012)			
R116	1-216-025-91	METAL GLAZE	100	5%	1/10W	R177	1-216-041-00	METAL CHIP 470	5%		1/10W
R117	1-216-295-91	CONDUCTOR, CHIP (2012)				R178	1-216-073-00	METAL CHIP 10K	5%		1/10W
R118	1-216-041-00	METAL CHIP	470	5%	1/10W						
R119	1-216-043-91	METAL GLAZE	560	5%	1/10W	R179	1-216-295-91	CONDUCTOR, CHIP (2012)			
R120	1-216-024-00	METAL GLAZE	91	5%	1/10W	R180	1-216-073-00	METAL CHIP 10K	5%		1/10W
						R181	1-216-073-00	METAL CHIP 10K	5%		1/10W
R121	1-216-049-91	METAL GLAZE	1K	5%	1/10W	R182	1-216-073-00	METAL CHIP 10K	5%		1/10W
R122	1-216-049-91	METAL GLAZE	1K	5%	1/10W	R183	1-216-043-91	METAL GLAZE 560	5%		1/10W
R123	1-216-065-00	METAL CHIP	4.7K	5%	1/10W						
R124	1-216-029-00	METAL CHIP	150	5%	1/10W	R184	1-216-073-00	METAL CHIP 10K	5%		1/10W
R125	1-216-057-00	METAL CHIP	2.2K	5%	1/10W	R185	1-216-295-91	CONDUCTOR, CHIP (2012)			
						R186	1-216-073-00	METAL CHIP 10K	5%		1/10W
R126	1-216-049-91	METAL GLAZE	1K	5%	1/10W	R187	1-216-073-00	METAL CHIP 10K	5%		1/10W
R127	1-216-049-91	METAL GLAZE	1K	5%	1/10W	R188	1-216-073-00	METAL CHIP 10K	5%		1/10W
R128	1-216-049-91	METAL GLAZE	1K	5%	1/10W						
R129	1-216-049-91	METAL GLAZE	1K	5%	1/10W	R193	1-216-295-91	CONDUCTOR, CHIP (2012)			
R130	1-216-055-00	METAL CHIP	1.8K	5%	1/10W	R194	1-216-295-91	CONDUCTOR, CHIP (2012)			
						R195	1-216-295-91	CONDUCTOR, CHIP (2012)			
R131	1-216-073-00	METAL CHIP	10K	5%	1/10W	R196	1-216-295-91	CONDUCTOR, CHIP (2012)			
R132	1-216-073-00	METAL CHIP	10K	5%	1/10W	R201	1-216-065-00	METAL CHIP 4.7K	5%		1/10W
R133	1-216-065-00	METAL CHIP	4.7K	5%	1/10W						
R134	1-216-049-91	METAL GLAZE	1K	5%	1/10W	R202	1-216-065-00	METAL CHIP 4.7K	5%		1/10W
R135	1-216-049-91	METAL GLAZE	1K	5%	1/10W	R203	1-216-065-00	METAL CHIP 4.7K	5%		1/10W
						R204	1-216-065-00	METAL CHIP 4.7K	5%		1/10W
R136	1-216-065-00	METAL CHIP	4.7K	5%	1/10W	R205	1-216-057-00	METAL CHIP 2.2K	5%		1/10W
R137	1-216-049-91	METAL GLAZE	1K	5%	1/10W	R206	1-216-017-91	METAL GLAZE 47	5%		1/10W
R138	1-216-073-00	METAL CHIP	10K	5%	1/10W						
R139	1-216-049-91	METAL GLAZE	1K	5%	1/10W	R207	1-216-065-00	METAL CHIP 4.7K	5%		1/10W
R140	1-216-061-00	METAL CHIP	3.3K	5%	1/10W	R208	1-216-065-00	METAL CHIP 4.7K	5%		1/10W
						R209	1-216-057-00	METAL CHIP 2.2K	5%		1/10W
R141	1-216-049-91	METAL GLAZE	1K	5%	1/10W	R210	1-216-017-91	METAL GLAZE 47	5%		1/10W
R142	1-216-071-00	METAL CHIP	8.2K	5%	1/10W	R211	1-216-065-00	METAL CHIP 4.7K	5%		1/10W
R143	1-216-097-91	METAL GLAZE	100K	5%	1/10W						
R144	1-216-081-00	METAL CHIP	22K	5%	1/10W	R212	1-216-073-00	METAL CHIP 10K	5%		1/10W
R145	1-216-063-91	METAL GLAZE	3.9K	5%	1/10W	R213	1-216-027-00	METAL CHIP 120	5%		1/10W
						R214	1-216-073-00	METAL CHIP 10K	5%		1/10W
R146	1-216-065-00	METAL CHIP	4.7K	5%	1/10W	R217	1-216-105-91	METAL GLAZE 220K	5%		1/10W
R147	1-216-089-91	METAL GLAZE	47K	5%	1/10W	R219	1-216-073-00	METAL CHIP 10K	5%		1/10W
R148	1-216-027-00	METAL CHIP	120	5%	1/10W						
R149	1-216-089-91	METAL GLAZE	47K	5%	1/10W	R224	1-216-049-91	METAL GLAZE 1K	5%		1/10W
R150	1-216-089-91	METAL GLAZE	47K	5%	1/10W	R231	1-216-025-91	METAL GLAZE 100	5%		1/10W
						R232	1-216-025-91	METAL GLAZE 100	5%		1/10W
R151	1-216-089-91	METAL GLAZE	47K	5%	1/10W	R244	1-216-295-91	CONDUCTOR, CHIP (2012)			
R152	1-216-073-00	METAL CHIP	10K	5%	1/10W	R245	1-216-025-91	METAL GLAZE 100	5%		1/10W
R153	1-216-073-00	METAL CHIP	10K	5%	1/10W						
R154	1-216-083-00	METAL CHIP	27K	5%	1/10W	R246	1-216-025-91	METAL GLAZE 100	5%		1/10W
R155	1-216-093-00	METAL CHIP	68K	5%	1/10W	R247	1-216-033-00	METAL CHIP 220	5%		1/10W
						R248	1-216-025-91	METAL GLAZE 100	5%		1/10W
R156	1-216-295-91	CONDUCTOR, CHIP (2012)				R249	1-216-025-91	METAL GLAZE 100	5%		1/10W
R157	1-216-017-91	METAL GLAZE	47	5%	1/10W	R250	1-216-025-91	METAL GLAZE 100	5%		1/10W
R158	1-216-025-91	METAL GLAZE	100	5%	1/10W						
R159	1-216-025-91	METAL GLAZE	100	5%	1/10W	R251	1-216-065-00	METAL CHIP 4.7K	5%		1/10W
R160	1-216-073-00	METAL CHIP	10K	5%	1/10W	R252	1-216-065-00	METAL CHIP 4.7K	5%		1/10W
						R253	1-216-065-00	METAL CHIP 4.7K	5%		1/10W
R161	1-216-073-00	METAL CHIP	10K	5%	1/10W	R254	1-216-065-00	METAL CHIP 4.7K	5%		1/10W
R162	1-216-081-00	METAL CHIP	22K	5%	1/10W	R255	1-216-057-00	METAL CHIP 2.2K	5%		1/10W

MAIN

Ref. No.	Part No.	Description	Remark	Ref. No.	Part No.	Description	Remark
R256	1-216-017-91	METAL GLAZE	47 5%	1/10W	R357	1-216-065-00	METAL CHIP 4.7K 5% 1/10W
R257	1-216-065-00	METAL CHIP	4.7K 5%	1/10W	R358	1-216-295-91	CONDUCTOR, CHIP (2012)
R258	1-216-065-00	METAL CHIP	4.7K 5%	1/10W	R359	1-216-073-00	METAL CHIP 10K 5% 1/10W
R259	1-216-057-00	METAL CHIP	2.2K 5%	1/10W	R360	1-216-073-00	METAL CHIP 10K 5% 1/10W
R260	1-216-017-91	METAL GLAZE	47 5%	1/10W	R361	1-216-295-91	CONDUCTOR, CHIP (2012)
R261	1-216-065-00	METAL CHIP	4.7K 5%	1/10W	R362	1-216-295-91	CONDUCTOR, CHIP (2012)
R262	1-216-073-00	METAL CHIP	10K 5%	1/10W	R363	1-216-295-91	CONDUCTOR, CHIP (2012)
R263	1-216-027-00	METAL CHIP	120 5%	1/10W	R364	1-216-073-00	METAL CHIP 10K 5% 1/10W
R264	1-216-073-00	METAL CHIP	10K 5%	1/10W	R365	1-216-073-00	METAL CHIP 10K 5% 1/10W
R271	1-216-073-00	METAL CHIP	10K 5%	1/10W	R366	1-216-076-00	METAL CHIP 13K 5% 1/10W
R272	1-216-073-00	METAL CHIP	10K 5%	1/10W	R367	1-216-076-00	METAL CHIP 13K 5% 1/10W
R285	1-216-121-91	METAL GLAZE	1M 5%	1/10W	R368	1-216-049-91	METAL GLAZE 1K 5% 1/10W
R286	1-216-081-00	METAL CHIP	22K 5%	1/10W	R369	1-216-057-00	METAL CHIP 2.2K 5% 1/10W
R287	1-216-081-00	METAL CHIP	22K 5%	1/10W	R370	1-216-079-00	METAL CHIP 18K 5% 1/10W
R291	1-216-025-91	METAL GLAZE	100 5%	1/10W	R371	1-216-056-00	METAL GLAZE 2K 5% 1/10W
R292	1-216-025-91	METAL GLAZE	100 5%	1/10W	R372	1-216-097-91	METAL GLAZE 100K 5% 1/10W
R293	1-216-025-91	METAL GLAZE	100 5%	1/10W	R373	1-216-041-00	METAL CHIP 470 5% 1/10W
R301	1-216-065-00	METAL CHIP	4.7K 5%	1/10W	R374	1-216-041-00	METAL CHIP 470 5% 1/10W
R302	1-216-065-00	METAL CHIP	4.7K 5%	1/10W	R375	1-216-065-00	METAL CHIP 4.7K 5% 1/10W
R303	1-216-065-00	METAL CHIP	4.7K 5%	1/10W	R376	1-216-065-00	METAL CHIP 4.7K 5% 1/10W
R304	1-216-065-00	METAL CHIP	4.7K 5%	1/10W	R377	1-216-097-91	METAL GLAZE 100K 5% 1/10W
R306	1-216-065-00	METAL CHIP	4.7K 5%	1/10W	R378	1-216-081-00	METAL CHIP 22K 5% 1/10W
R307	1-216-065-00	METAL CHIP	4.7K 5%	1/10W	R381	1-216-077-00	METAL CHIP 15K 5% 1/10W
R308	1-216-295-91	CONDUCTOR, CHIP (2012)			R389	1-216-049-91	METAL GLAZE 1K 5% 1/10W
R309	1-216-073-00	METAL CHIP	10K 5%	1/10W	R390	1-216-097-91	METAL GLAZE 100K 5% 1/10W
R310	1-216-073-00	METAL CHIP	10K 5%	1/10W	R391	1-216-049-91	METAL GLAZE 1K 5% 1/10W
R311	1-216-295-91	CONDUCTOR, CHIP (2012)			R393	1-216-079-00	METAL CHIP 18K 5% 1/10W
R312	1-216-295-91	CONDUCTOR, CHIP (2012)			R394	1-216-097-91	METAL GLAZE 100K 5% 1/10W
R313	1-216-295-91	CONDUCTOR, CHIP (2012)			R395	1-216-025-91	METAL GLAZE 100 5% 1/10W
R314	1-216-073-00	METAL CHIP	10K 5%	1/10W	R396	1-216-065-00	METAL CHIP 4.7K 5% 1/10W
R315	1-216-073-00	METAL CHIP	10K 5%	1/10W	R510	1-216-021-00	METAL CHIP 68 5% 1/10W
R316	1-216-076-00	METAL CHIP	13K 5%	1/10W	R511	1-216-021-00	METAL CHIP 68 5% 1/10W
R317	1-216-076-00	METAL CHIP	13K 5%	1/10W	R512	1-216-021-00	METAL CHIP 68 5% 1/10W
R318	1-216-049-91	METAL GLAZE	1K 5%	1/10W	R513	1-216-021-00	METAL CHIP 68 5% 1/10W
R319	1-216-057-00	METAL CHIP	2.2K 5%	1/10W	R901	1-216-057-00	METAL CHIP 2.2K 5% 1/10W
R320	1-216-079-00	METAL CHIP	18K 5%	1/10W	R902	1-216-073-00	METAL CHIP 10K 5% 1/10W
R321	1-216-056-00	METAL GLAZE	2K 5%	1/10W	R903	1-216-045-00	METAL CHIP 680 5% 1/10W
R322	1-216-097-91	METAL GLAZE	100K 5%	1/10W	△R904	1-219-121-11	FUSIBLE 0.22 5% 1/4W F
R323	1-216-041-00	METAL CHIP	470 5%	1/10W	△R905	1-212-934-00	FUSIBLE 1 5% 1/2W F
R324	1-216-041-00	METAL CHIP	470 5%	1/10W	R1301	1-216-065-00	METAL CHIP 4.7K 5% 1/10W
R325	1-216-065-00	METAL CHIP	4.7K 5%	1/10W	R1302	1-216-065-00	METAL CHIP 4.7K 5% 1/10W
R326	1-216-065-00	METAL CHIP	4.7K 5%	1/10W	R1303	1-216-065-00	METAL CHIP 4.7K 5% 1/10W
R327	1-216-097-91	METAL GLAZE	100K 5%	1/10W	R1304	1-216-065-00	METAL CHIP 4.7K 5% 1/10W
R328	1-216-081-00	METAL CHIP	22K 5%	1/10W	R1306	1-216-065-00	METAL CHIP 4.7K 5% 1/10W
R331	1-216-077-00	METAL CHIP	15K 5%	1/10W	R1307	1-216-065-00	METAL CHIP 4.7K 5% 1/10W
R339	1-216-049-91	METAL GLAZE	1K 5%	1/10W	R1308	1-216-295-91	CONDUCTOR, CHIP (2012)
R340	1-216-97-91	METAL GLAZE	100K 5%	1/10W	R1309	1-216-073-00	METAL CHIP 10K 5% 1/10W
R341	1-216-049-91	METAL GLAZE	1K 5%	1/10W	R1310	1-216-073-00	METAL CHIP 10K 5% 1/10W
R343	1-216-079-00	METAL CHIP	18K 5%	1/10W	R1311	1-216-295-91	CONDUCTOR, CHIP (2012)
R344	1-216-097-91	METAL GLAZE	100K 5%	1/10W	R1312	1-216-295-91	CONDUCTOR, CHIP (2012)
R345	1-216-025-91	METAL GLAZE	100 5%	1/10W	R1313	1-216-295-91	CONDUCTOR, CHIP (2012)
R346	1-216-065-00	METAL CHIP	4.7K 5%	1/10W	R1314	1-216-073-00	METAL CHIP 10K 5% 1/10W
R347	1-216-073-00	METAL CHIP	10K 5%	1/10W	R1315	1-216-073-00	METAL CHIP 10K 5% 1/10W
R348	1-216-065-00	METAL CHIP	4.7K 5%	1/10W	R1316	1-216-076-00	METAL CHIP 13K 5% 1/10W
R351	1-216-065-00	METAL CHIP	4.7K 5%	1/10W	R1317	1-216-076-00	METAL CHIP 13K 5% 1/10W
R352	1-216-065-00	METAL CHIP	4.7K 5%	1/10W	R1318	1-216-049-91	METAL GLAZE 1K 5% 1/10W
R353	1-216-065-00	METAL CHIP	4.7K 5%	1/10W	R1319	1-216-057-00	METAL CHIP 2.2K 5% 1/10W
R354	1-216-065-00	METAL CHIP	4.7K 5%	1/10W			
R356	1-216-065-00	METAL CHIP	4.7K 5%	1/10W			

The components identified by mark △ or dotted line with mark △ are critical for safety. Replace only with part number specified.	Les composants identifiés par une marque △ sont critiques pour la sécurité. Ne les remplacer que par une pièce portant le numéro spécifié.
--	--

Ref. No.	Part No.	Description	Remark	Ref. No.	Part No.	Description	Remark
R1320	1-216-079-00	METAL CHIP	18K 5% 1/10W	R2308	1-216-295-91	CONDUCTOR, CHIP (2012)	
R1321	1-216-056-00	METAL GLAZE	2K 5% 1/10W	R2309	1-216-073-00	METAL CHIP	10K 5% 1/10W
R1323	1-216-041-00	METAL CHIP	470 5% 1/10W	R2310	1-216-073-00	METAL CHIP	10K 5% 1/10W
R1324	1-216-041-00	METAL CHIP	470 5% 1/10W	R2311	1-216-295-91	CONDUCTOR, CHIP (2012)	
R1325	1-216-065-00	METAL CHIP	4.7K 5% 1/10W	R2312	1-216-295-91	CONDUCTOR, CHIP (2012)	
R1326	1-216-065-00	METAL CHIP	4.7K 5% 1/10W	R2313	1-216-295-91	CONDUCTOR, CHIP (2012)	
R1327	1-216-097-91	METAL GLAZE	100K 5% 1/10W	R2314	1-216-073-00	METAL CHIP	10K 5% 1/10W
R1328	1-216-085-00	METAL GLAZE	33K 5% 1/10W	R2315	1-216-073-00	METAL CHIP	10K 5% 1/10W
R1331	1-216-073-00	METAL CHIP	10K 5% 1/10W	R2316	1-216-076-00	METAL CHIP	13K 5% 1/10W
R1339	1-216-049-91	METAL GLAZE	1K 5% 1/10W	R2317	1-216-076-00	METAL CHIP	13K 5% 1/10W
R1340	1-216-097-91	METAL GLAZE	100K 5% 1/10W	R2318	1-216-049-91	METAL GLAZE	1K 5% 1/10W
R1341	1-216-049-91	METAL GLAZE	1K 5% 1/10W	R2319	1-216-057-00	METAL CHIP	2.2K 5% 1/10W
R1343	1-216-079-00	METAL CHIP	18K 5% 1/10W	R2320	1-216-079-00	METAL CHIP	18K 5% 1/10W
R1344	1-216-097-91	METAL GLAZE	100K 5% 1/10W	R2321	1-216-056-00	METAL GLAZE	2K 5% 1/10W
R1345	1-216-025-91	METAL GLAZE	100 5% 1/10W	R2323	1-216-041-00	METAL CHIP	470 5% 1/10W
R1346	1-216-065-00	METAL CHIP	4.7K 5% 1/10W	R2324	1-216-041-00	METAL CHIP	470 5% 1/10W
R1347	1-216-073-00	METAL CHIP	10K 5% 1/10W	R2325	1-216-065-00	METAL CHIP	4.7K 5% 1/10W
R1348	1-216-065-00	METAL CHIP	4.7K 5% 1/10W	R2326	1-216-065-00	METAL CHIP	4.7K 5% 1/10W
R1351	1-216-065-00	METAL CHIP	4.7K 5% 1/10W	R2327	1-216-097-91	METAL GLAZE	100K 5% 1/10W
R1352	1-216-065-00	METAL CHIP	4.7K 5% 1/10W	R2328	1-216-085-00	METAL CHIP	33K 5% 1/10W
R1353	1-216-065-00	METAL CHIP	4.7K 5% 1/10W	R2331	1-216-073-00	METAL CHIP	10K 5% 1/10W
R1354	1-216-065-00	METAL CHIP	4.7K 5% 1/10W	R2339	1-216-049-91	METAL GLAZE	1K 5% 1/10W
R1356	1-216-065-00	METAL CHIP	4.7K 5% 1/10W	R2340	1-216-097-91	METAL GLAZE	100K 5% 1/10W
R1357	1-216-065-00	METAL CHIP	4.7K 5% 1/10W	R2341	1-216-049-91	METAL GLAZE	1K 5% 1/10W
R1358	1-216-295-91	CONDUCTOR, CHIP (2012)		R2343	1-216-079-00	METAL CHIP	18K 5% 1/10W
R1359	1-216-073-00	METAL CHIP	10K 5% 1/10W	R2344	1-216-097-91	METAL GLAZE	100K 5% 1/10W
R1360	1-216-073-00	METAL CHIP	10K 5% 1/10W	R2345	1-216-025-91	METAL GLAZE	100 5% 1/10W
R1361	1-216-295-91	CONDUCTOR, CHIP (2012)		R2346	1-216-065-00	METAL CHIP	4.7K 5% 1/10W
R1362	1-216-295-91	CONDUCTOR, CHIP (2012)		R2347	1-216-073-00	METAL CHIP	10K 5% 1/10W
R1363	1-216-295-91	CONDUCTOR, CHIP (2012)		R2348	1-216-065-00	METAL CHIP	4.7K 5% 1/10W
R1364	1-216-073-00	METAL CHIP	10K 5% 1/10W	R2351	1-216-065-00	METAL CHIP	4.7K 5% 1/10W
R1365	1-216-073-00	METAL CHIP	10K 5% 1/10W	R2352	1-216-065-00	METAL CHIP	4.7K 5% 1/10W
R1366	1-216-076-00	METAL CHIP	13K 5% 1/10W	R2353	1-216-065-00	METAL CHIP	4.7K 5% 1/10W
R1367	1-216-076-00	METAL CHIP	13K 5% 1/10W	R2354	1-216-065-00	METAL CHIP	4.7K 5% 1/10W
R1368	1-216-049-91	METAL GLAZE	1K 5% 1/10W	R2356	1-216-065-00	METAL CHIP	4.7K 5% 1/10W
R1369	1-216-057-00	METAL CHIP	2.2K 5% 1/10W	R2357	1-216-065-00	METAL CHIP	4.7K 5% 1/10W
R1370	1-216-076-00	METAL CHIP	13K 5% 1/10W	R2358	1-216-295-91	CONDUCTOR, CHIP (2012)	
R1371	1-216-056-00	METAL GLAZE	2K 5% 1/10W	R2359	1-216-073-00	METAL CHIP	10K 5% 1/10W
R1373	1-216-041-00	METAL CHIP	470 5% 1/10W	R2360	1-216-073-00	METAL CHIP	10K 5% 1/10W
R1374	1-216-041-00	METAL CHIP	470 5% 1/10W	R2361	1-216-295-91	CONDUCTOR, CHIP (2012)	
R1375	1-216-065-00	METAL CHIP	4.7K 5% 1/10W	R2362	1-216-295-91	CONDUCTOR, CHIP (2012)	
R1376	1-216-065-00	METAL CHIP	4.7K 5% 1/10W	R2363	1-216-295-91	CONDUCTOR, CHIP (2012)	
R1377	1-216-097-91	METAL GLAZE	100K 5% 1/10W	R2364	1-216-073-00	METAL CHIP	10K 5% 1/10W
R1378	1-216-085-00	METAL CHIP	33K 5% 1/10W	R2365	1-216-073-00	METAL CHIP	10K 5% 1/10W
R1381	1-216-073-00	METAL CHIP	10K 5% 1/10W	R2366	1-216-076-00	METAL CHIP	13K 5% 1/10W
R1389	1-216-049-91	METAL GLAZE	1K 5% 1/10W	R2367	1-216-076-00	METAL CHIP	13K 5% 1/10W
R1390	1-216-097-91	METAL GLAZE	100K 5% 1/10W	R2368	1-216-049-91	METAL GLAZE	1K 5% 1/10W
R1391	1-216-049-91	METAL GLAZE	1K 5% 1/10W	R2369	1-216-057-00	METAL CHIP	2.2K 5% 1/10W
R1393	1-216-079-00	METAL CHIP	18K 5% 1/10W	R2370	1-216-079-00	METAL CHIP	18K 5% 1/10W
R1394	1-216-097-91	METAL GLAZE	100K 5% 1/10W	R2371	1-216-056-00	METAL GLAZE	2K 5% 1/10W
R1395	1-216-025-91	METAL GLAZE	100 5% 1/10W	R2373	1-216-041-00	METAL CHIP	470 5% 1/10W
R1396	1-216-065-00	METAL CHIP	4.7K 5% 1/10W	R2374	1-216-041-00	METAL CHIP	470 5% 1/10W
R2301	1-216-065-00	METAL CHIP	4.7K 5% 1/10W	R2375	1-216-065-00	METAL CHIP	4.7K 5% 1/10W
R2302	1-216-065-00	METAL CHIP	4.7K 5% 1/10W	R2376	1-216-065-00	METAL CHIP	4.7K 5% 1/10W
R2303	1-216-065-00	METAL CHIP	4.7K 5% 1/10W	R2377	1-216-097-91	METAL GLAZE	100K 5% 1/10W
R2304	1-216-065-00	METAL CHIP	4.7K 5% 1/10W	R2378	1-216-085-00	METAL CHIP	33K 5% 1/10W
R2306	1-216-065-00	METAL CHIP	4.7K 5% 1/10W	R2381	1-216-073-00	METAL CHIP	10K 5% 1/10W
R2307	1-216-065-00	METAL CHIP	4.7K 5% 1/10W				

MAIN **PLL** **TRANS**

Ref. No.	Part No.	Description	Remark
R2389	1-216-049-91	METAL GLAZE 1K 5%	1/10W
R2390	1-216-097-91	METAL GLAZE 100K 5%	1/10W
R2391	1-216-049-91	METAL GLAZE 1K 5%	1/10W
R2393	1-216-079-00	METAL CHIP 18K 5%	1/10W
R2394	1-216-097-91	METAL GLAZE 100K 5%	1/10W
R2395	1-216-025-91	METAL GLAZE 100 5%	1/10W
R2396	1-216-065-00	METAL CHIP 4.7K 5%	1/10W
< VARIABLE RESISTOR >			
RV101	1-241-765-11	RES, ADJ, CARBON 22K	
< RELAY >			
RY301	1-515-614-11	RELAY	
RY1301	1-515-614-11	RELAY	
RY2301	1-515-614-11	RELAY	
< VIBRATOR >			
X101	1-767-434-11	VIBRATOR, CRYSTAL (18.432MHz)	
X102	1-767-576-11	VIBRATOR, CRYSTAL (12.288MHz)	
X103	1-567-819-11	VIBRATOR, CERAMIC (4MHz)	

*	A-4403-394-A	PLL BOARD, COMPLETE (US,CND)	

*	A-4403-395-A	PLL BOARD, COMPLETE (AEP,UK,E,SP,CH,AUS)	

< CAPACITOR >			
C701	1-163-275-11	CERAMIC CHIP 0.001uF 5%	50V
C702	1-165-319-11	CERAMIC CHIP 0.1uF	50V
C703	1-163-093-00	CERAMIC CHIP 10PF 5%	50V
C704	1-163-093-00	CERAMIC CHIP 10PF 5%	50V
C705	1-163-249-11	CERAMIC CHIP 82PF 5%	50V
C706	1-163-243-11	CERAMIC CHIP 47PF 5%	50V
C707	1-126-964-11	ELECT 10uF 20%	50V
C708	1-130-483-00	MYLAR 0.01uF 5%	50V
C709	1-126-933-11	ELECT 100uF 20%	16V
C710	1-165-319-11	CERAMIC CHIP 0.1uF	50V
C711	1-130-490-11	MYLAR 0.039uF 5%	50V
< DIODE >			
D701	8-719-951-05	DIODE KV1560	
< IC >			
IC701	8-759-250-81	IC TC5081AP	
< COIL >			
L701	1-410-381-11	CHIP INDUCTOR 10uH	
L702	1-426-850-11	COIL (RF)	
L703	1-410-381-11	CHIP INDUCTOR 10uH	
< TRANSISTOR >			
Q701	8-729-232-11	TRANSISTOR 2SK302-GR-TE85L	
Q702	8-729-232-11	TRANSISTOR 2SK302-GR-TE85L	
Q703	8-729-230-49	TRANSISTOR 2SC2712-YG	
Q704	8-729-230-49	TRANSISTOR 2SC2712-YG	
Q705	8-729-230-49	TRANSISTOR 2SC2712-YG	

Ref. No.	Part No.	Description	Remark
< RESISTOR >			
R701	1-216-049-91	METAL GLAZE 1K 5%	1/10W
R702	1-216-049-91	METAL GLAZE 1K 5%	1/10W
R703	1-216-097-91	METAL GLAZE 100K 5%	1/10W
R704	1-216-073-00	METAL CHIP 10K 5%	1/10W
R705	1-216-071-00	METAL CHIP 8.2K 5%	1/10W
R706	1-216-073-00	METAL CHIP 10K 5%	1/10W
R707	1-216-073-00	METAL CHIP 10K 5%	1/10W
R708	1-216-049-91	METAL GLAZE 1K 5%	1/10W
R709	1-216-057-00	METAL CHIP 2.2K 5%	1/10W
R710	1-216-017-91	METAL GLAZE 47 5%	1/10W
R711	1-216-049-91	METAL GLAZE 1K 5%	1/10W
R712	1-216-065-00	METAL CHIP 4.7K 5%	1/10W
R713	1-216-049-91	METAL GLAZE 1K 5%	1/10W
R714	1-216-295-91	CONDUCTOR, CHIP (2012)	
R715	1-216-295-91	CONDUCTOR, CHIP (2012)	
R716	1-216-295-91	CONDUCTOR, CHIP (2012)	
R722	1-216-025-91	METAL CHIP 100 5%	1/10W
R723	1-216-025-91	METAL CHIP 100 5%	1/10W
R724	1-216-025-91	METAL CHIP 100 5%	1/10W

*	1-666-567-11	TRANS BOARD	

< CAPACITOR >			
△C801	1-115-383-11	CERAMIC 0.001uF 10%	125V
< CONNECTOR >			
CN801	1-774-108-11	PIN, CONNECTOR (PC BOARD)	
CN802	1-564-321-00	PIN, CONNECTOR 2P	
< DIODE >			
D901	8-719-200-02	DIODE 10E2	
D902	8-719-200-02	DIODE 10E2	
D903	8-719-200-02	DIODE 10E2	
D904	8-719-200-02	DIODE 10E2	
D909	8-719-200-82	DIODE 11ES2	
D910	8-719-200-82	DIODE 11ES2	
D911	8-719-200-82	DIODE 11ES2	
D912	8-719-200-82	DIODE 11ES2	
< COIL >			
△L801	1-421-915-11	COIL, LINE FILTER	
< RESISTOR >			
△R906	1-219-122-91	FUSIBLE 0.33 5%	1/4W F
△R907	1-219-122-91	FUSIBLE 0.33 5%	1/4W F
△R908	1-219-153-11	FUSIBLE 10 5%	1/4W F
< TRANSFORMER >			
△T1	1-431-453-11	TRANSFORMER, POWER (US,CND)	
△T1	1-431-455-11	TRANSFORMER, POWER (AEP,UK,E,SPAUS,CH)	

The components identified by mark △ or dotted line with mark △ are critical for safety. Replace only with part number specified.	Les composants identifiés par une marque △ sont critiques pour la sécurité. Ne les remplacer que par une pièce portant le numéro spécifié.
--	--

<u>Ref. No.</u>	<u>Part No.</u>	<u>Description</u>	<u>Remark</u>	<u>Ref. No.</u>	<u>Part No.</u>	<u>Description</u>	<u>Remark</u>
*	1-666-565-11	VOL BOARD *****					
		< CONNECTOR >					
CN603	1-506-469-11	PIN, CONNECTOR 4P					
CN604	1-568-802-11	SOCKET, CONNECTOR 19P					
		< RESISTOR >					
R651	1-249-411-11	CARBON 330 5% 1/4W					
		< VARIABLE RESISTOR >					
RV601	1-225-491-11	RES, VAR (MASTER VOLUME)					

		MISCELLANEOUS *****					
10	1-769-943-11	WIRE (FLAT TYPE)(11 CORE)					
11	1-773-116-11	WIRE (FLAT TYPE)(19 CORE)					
△ 18	1-558-945-21	CORD, POWER (POLAR.SPT-1)(US,CND)					
△ 18	1-696-845-11	CORD, POWER (AUS)					
△ 18	1-775-787-41	CORD, POWER (AEP,UK,E,SP)					
△ 18	1-782-464-21	CORD, POWER (CH)					
△ 20	1-569-008-11	ADAPTOR, CONVERSION 2P (E,SP)					
58	1-769-077-31	LEAD (WITH CONNECTOR)(2 CORE)					
FL601	1-517-671-11	INDICATOR TUBE, FLUORESCENT					
△ T1	1-431-453-11	TRANSFORMER, POWER (US,CND)					
△ T1	1-431-455-11	TRANSFORMER, POWER (AEP,UK,E,SP,AUS,CH)					

		ACCESSORIES & PACKING MATERIALS *****					
	1-475-276-11	REMOTE COMMANDER (RM-E800)					
	1-558-271-11	CORD, CONNECTION (AUDIO 108cm)					
	3-860-721-11	MANUAL, INSTRUCTION (ENGLISH,FRENCH)(US,CND,E,SP,AUS,CH)					
	3-860-721-21	MANUAL, INSTRUCTION (SPANISH,CHINESE)(E,SP,CH)					
	3-860-721-31	MANUAL, INSTRUCTION (ENGLISH,FRENCH,SPANISH,PORTUGUESE)(AEP,UK)					
	3-860-721-41	MANUAL, INSTRUCTION (GERMAN,DUTCH,SWEDISH,ITALIAN)(AEP,UK)					
	4-981-643-01	COVER, BATTERY (for RM-E800)					

		***** HARDWARE LIST *****					
#1	7-685-646-79	SCREW +BVTP 3X8 TYPE2 N-S					
#2	7-685-647-79	SCREW +BVTP 3X10 TYPE2 N-S					
#3	7-685-872-09	SCREW +BVTT 3X8 (S)					
#4	7-685-880-09	SCREW +BVTT 4X6 (S)					

The components identified by mark △ or dotted line with mark △ are critical for safety. Replace only with part number specified.	Les composants identifiés par une marque △ sont critiques pour la sécurité. Ne les remplacer que par une pièce portant le numéro spécifié.
--	--

SDP-E800

SONY

SERVICE MANUAL

*US Model
Canadian Model
AEP Model
UK Model
E Model
Australian Model
Chinese Model*

SUPPLEMENT-1

File this supplement with the service manual.

**Subject : 1. CORRECTION
2. BOARD AND PARTS CHANGED**

(ECN-TA703556)

1. CORRECTION

- Correct your service manual as show below.

Page	INCORRECT						CORRECT					
	Ref. No.	Part No.	Description	Remark			Ref. No.	Part No.	Description	Remark		
61	*** EXPLODED VIEWS ***						*** EXPLODED VIEWS ***					
	51	X-4949-003-1	FOOT ASSY (GOLD)...(GOLD)				51	X-4947-555-1	FOOT ASSY (GOLD)...(GOLD)			
64	*** ELECTRICAL PARTS LIST ***						*** ELECTRICAL PARTS LIST ***					
	*** MAIN BOARD ***						*** MAIN BOARD ***					
	_____						C183	1-163-275-11	CERAMIC CHIP	0.001uF	5%	50V
	_____						C362	1-165-319-11	CERAMIC CHIP	0.1uF		50V
	_____						C919	1-115-419-11	CERAMIC CHIP	3300PF	5%	25V
	_____						C924	1-115-419-11	CERAMIC CHIP	3300PF	5%	25V
	_____						C925	1-115-419-11	CERAMIC CHIP	3300PF	5%	25V
	_____						C926	1-115-419-11	CERAMIC CHIP	3300PF	5%	25V
	_____						C927	1-115-419-11	CERAMIC CHIP	3300PF	5%	25V
	_____						C928	1-115-419-11	CERAMIC CHIP	3300PF	5%	25V
65	_____						* EP101	1-537-738-21	TERMINAL, EARTH			
	_____						* EP901	1-537-738-21	TERMINAL, EARTH			
68	R340	1-216-97-91	METAL GLAZE	100K	5%	1/10W	R340	1-216-097-91	METAL GLAZE	100K	5%	1/10W
							R399	1-216-296-91	CONDUCTOR CHIP			
69	_____						R1399	1-216-296-91	CONDUCTOR CHIP			
70	_____						R2399	1-216-296-91	CONDUCTOR CHIP			
	*** PLL BOARD ***						*** PLL BOARD ***					
	_____						C719	1-165-319-11	CERAMIC CHIP	0.1uF		50V
	_____						C720	1-165-319-11	CERAMIC CHIP	0.1uF		50V
	_____						CN701	1-695-095-11	SOCKET, CONNECTOR 13P			
	_____						F701	1-424-544-11	FERRITE	0uH		
	_____						F702	1-424-544-11	FERRITE	0uH		
	_____						F703	1-424-544-11	FERRITE	0uH		
	_____						L704	1-410-381-11	CHIP, INDUCTOR	10uH		
	_____						R721	1-216-121-91	METAL CHIP	1M	5%	1/10W



2. BOARD AND PARTS CHANGED

• Correct your service manual as show below.

Page	FORMER				NEW			
	Ref. No.	Part No.	Description	Remark	Ref. No.	Part No.	Description	Remark
63	*** ELECTRICAL PARTS LIST *** *** MAIN BOARD *** _____				*** ELECTRICAL PARTS LIST *** *** MAIN BOARD *** C176 1-126-961-11 ELECT 2.2uF 20% 50V			
64	_____ _____ _____ _____				C332 1-163-251-11 CERAMIC CHIP 100PF 5% 50V C382 1-163-251-11 CERAMIC CHIP 100PF 5% 50V C930 1-163-251-11 CERAMIC CHIP 100PF 5% 50V C931 1-163-251-11 CERAMIC CHIP 100PF 5% 50V			
65	_____ _____ _____				C1332 1-163-251-11 CERAMIC CHIP 100PF 5% 50V C1382 1-163-251-11 CERAMIC CHIP 100PF 5% 50V C2332 1-163-251-11 CERAMIC CHIP 100PF 5% 50V C2382 1-163-251-11 CERAMIC CHIP 100PF 5% 50V			
66	IC113	8-759-441-94	IC IDT71256SA20Y-TL		IC113	8-759-441-94	IC IDT71256SA20Y-TL	
	IC150	8-759-476-33	IC MB90641APF-G-102-BND		IC150	8-759-492-86	IC MB90641APF-G-107-BND	
	JR109	1-216-295-91	CONDUCTOR, CHIP				DELETE	
			_____		L301	1-410-381-11	INDUCTOR CHIP 10uH	
			_____		L1301	1-410-381-11	INDUCTOR CHIP 10uH	
			_____		L2301	1-410-381-11	INDUCTOR CHIP 10uH	
			_____		Q109	8-729-230-49	TRANSISTOR 2SC2712-YG	
			_____		Q201	8-729-107-46	TRANSISTOR 2SC3624-L15	
			_____		Q251	8-729-107-46	TRANSISTOR 2SC3624-L15	
67			_____		R189	1-216-025-91	METAL GLAZE 100 5% 1/10W	
			_____		R190	1-216-025-91	METAL GLAZE 100 5% 1/10W	
			_____		R191	1-216-025-91	METAL GLAZE 100 5% 1/10W	
			_____		R199	1-216-073-00	METAL CHIP 10K 5% 1/10W	
			_____		R215	1-216-025-91	METAL GLAZE 100 5% 1/10W	
			_____		R216	1-216-025-91	METAL GLAZE 100 5% 1/10W	
	R217	1-216-105-91	METAL GLAZE 220K 5% 1/10W		R217	1-216-025-91	METAL GLAZE 100 5% 1/10W	
			_____		R218	1-216-025-91	METAL GLAZE 100 5% 1/10W	
			_____		R220	1-216-025-91	METAL GLAZE 100 5% 1/10W	
			_____		R221	1-216-025-91	METAL GLAZE 100 5% 1/10W	
			_____		R223	1-216-065-00	METAL CHIP 4.7K 5% 1/10W	
			_____		R225	1-216-041-00	METAL CHIP 470 5% 1/10W	
68			_____		R273	1-216-065-00	METAL CHIP 4.7K 5% 1/10W	
			_____		R275	1-216-041-00	METAL CHIP 470 5% 1/10W	
	R341	1-216-049-91	METAL GLAZE 1K 5% 1/10W		R341	1-216-051-00	METAL GLAZE 1.2K 5% 1/10W	
	R391	1-216-049-91	METAL GLAZE 1K 5% 1/10W		R391	1-216-051-00	METAL GLAZE 1.2K 5% 1/10W	
70	*** TRANS BOARD *** _____ _____ _____				*** TRANS BOARD *** C922 1-164-159-11 CERAMIC CHIP 0.1uF 5% 50V C923 1-165-319-11 CERAMIC CHIP 0.1uF 5% 50V C924 1-165-319-11 CERAMIC CHIP 0.1uF 5% 50V C925 1-165-319-11 CERAMIC CHIP 0.1uF 5% 50V C926 1-165-319-11 CERAMIC CHIP 0.1uF 5% 50V			
	△ R906	1-219-122-91	FUSIBLE 0.33 5% 1/4W F		△ R906	1-219-153-11	FUSIBLE 10 5% 1/10W F	
	△ R908	1-219-153-11	FUSIBLE 10 5% 1/4W F		△ R908	1-219-122-91	FUSIBLE 0.33 5% 1/4W F	

The components identified by mark △ or dotted line with mark △ are critical for safety. Replace only with part number specified.	Les composants identifiés par une marque △ sont critiques pour la sécurité. Ne les remplacer que par une pièce portant le numéro spécifié.
--	--

PRINTED WIRING BOARD — MAIN SECTION — Page 23-36

 : indicates corrected portion
 : indicates changed portion

MAIN BOARD (SIDE A) & PLL BOARD
 Location A-K, 7-19

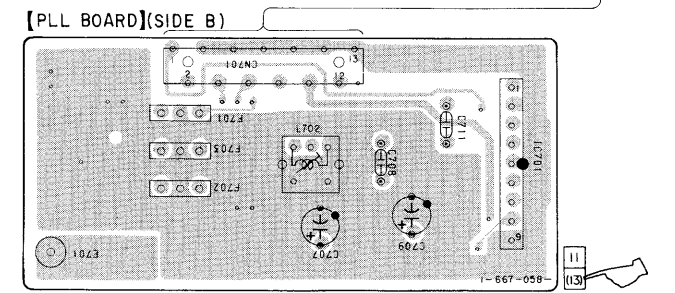
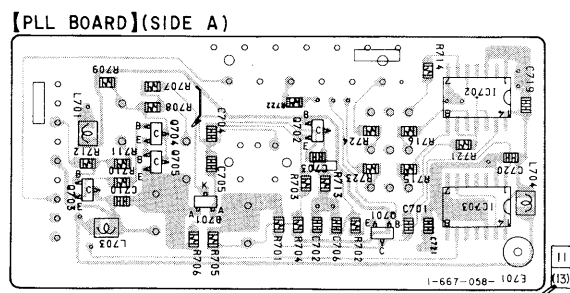
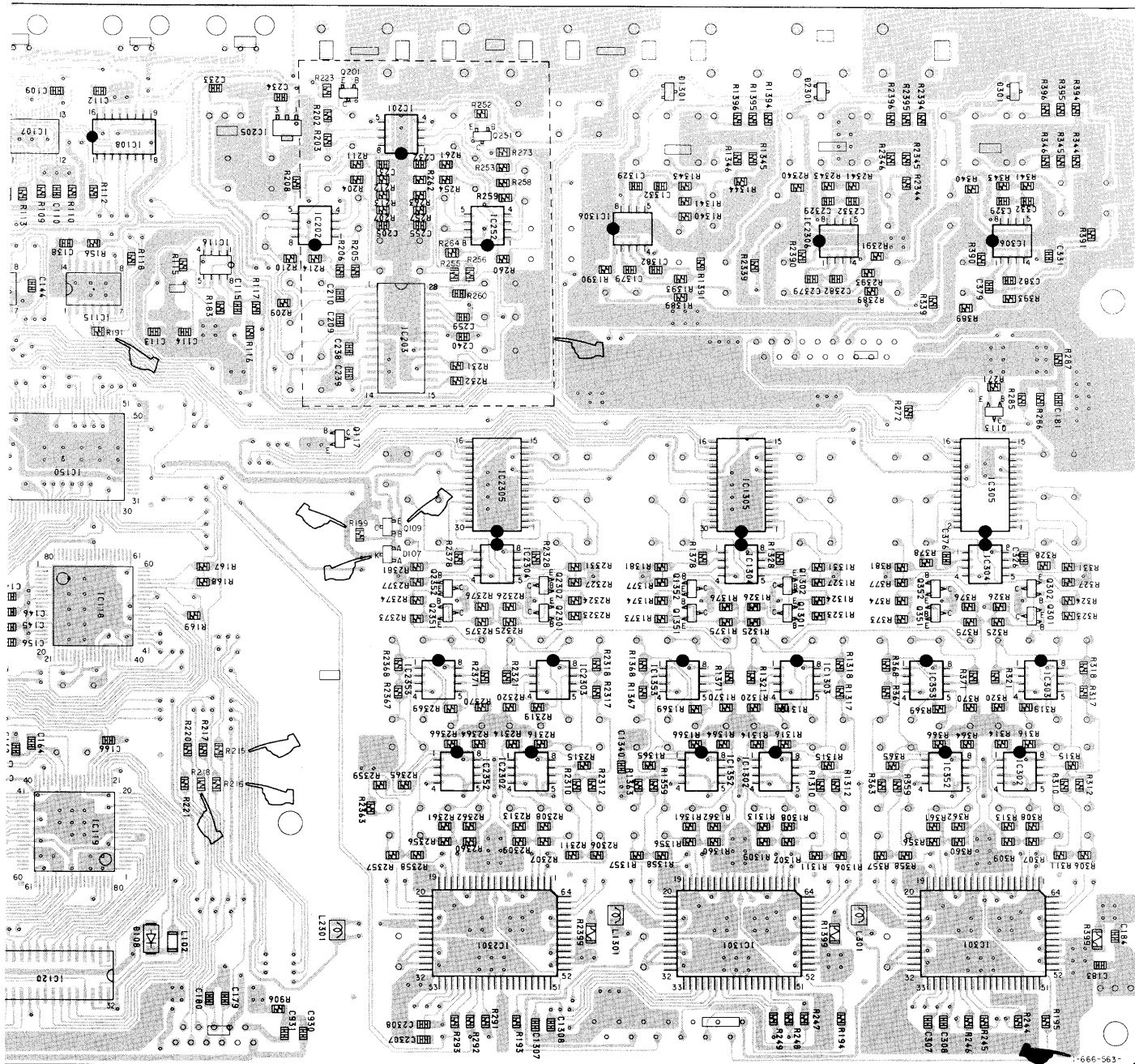

MAIN BOARD (SIDE B)
 Location A-E, 21-26

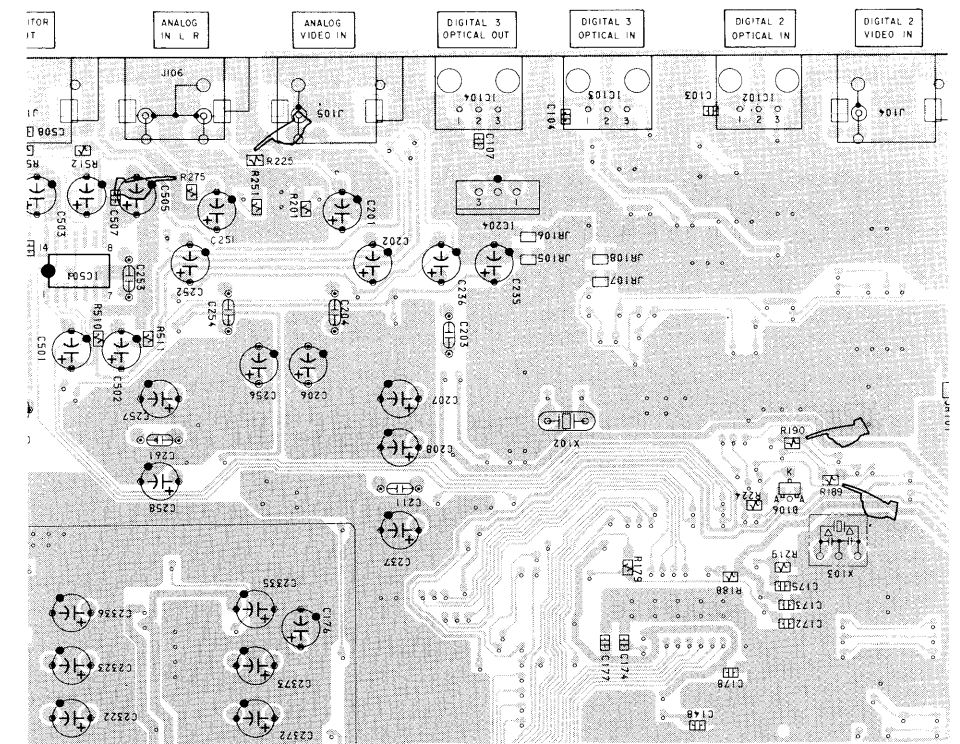

MAIN BOARD (SIDE B)
 Location H-J, 27-31

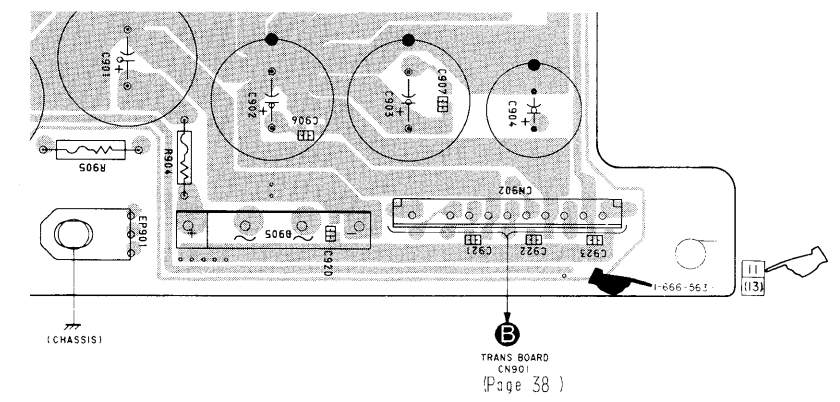

SCHEMATIC DIAGRAM — D/A SECTION — Page 27-30

⬇️ : indicates corrected portion
⬆️ : indicates changed portion

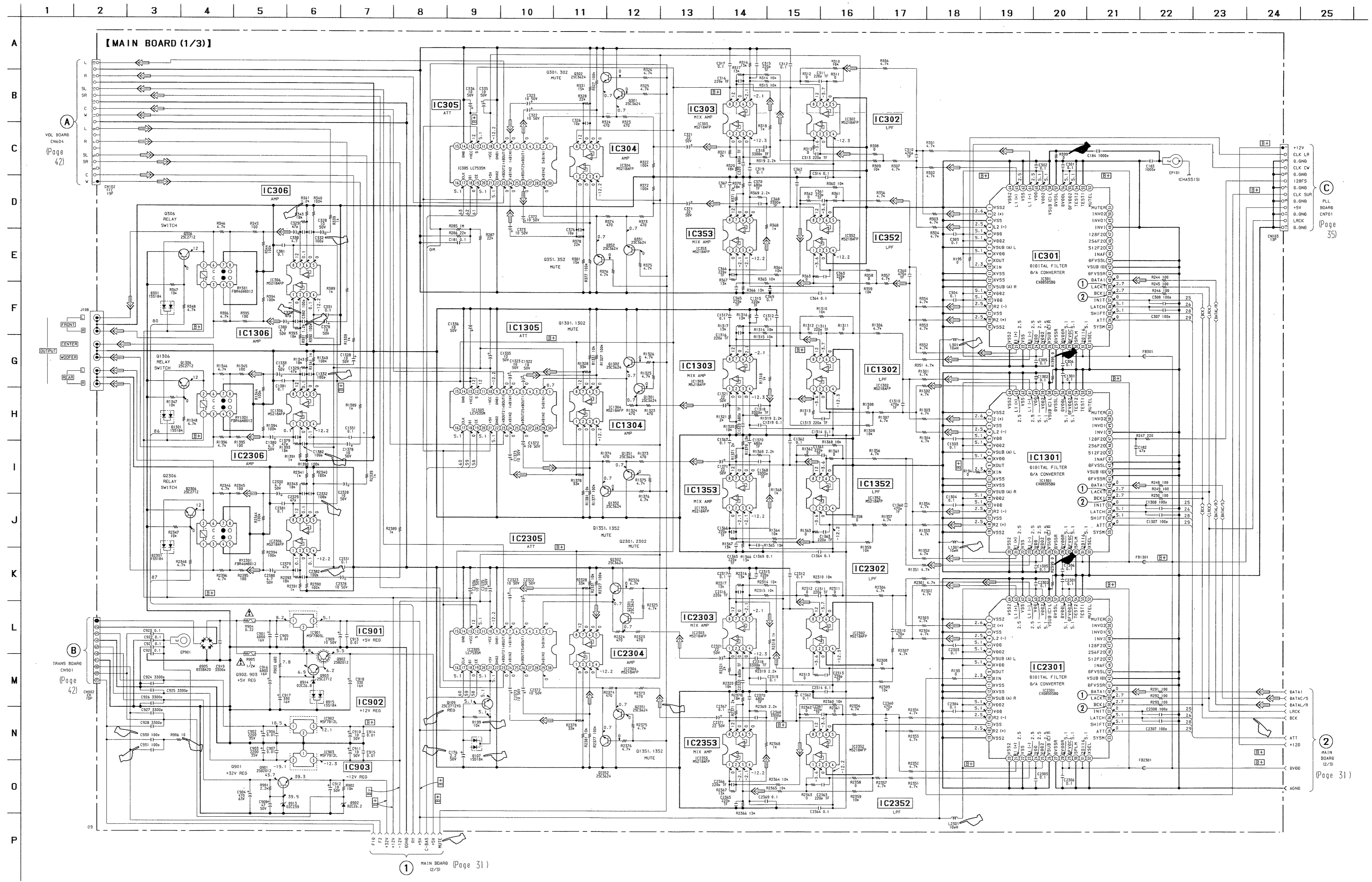

SCHEMATIC DIAGRAM — DISPLAY SECTION — Page 42, 43
Location D-I, 17-24

 : indicates changed portion

