

SERVICE MANUAL

TWO-SPEED AUTO-RETURN TURNTABLE

SANSUI SR-212



Sansui

SANSUI ELECTRIC CO., LTD.

This service manual is designed for service engineers to repair, adjust, maintain and order the replacement parts of the SR-212 correctly. When ordering the parts, use the stock number and parts name specifically referring to the parts list.

For general usage and maintenance of the unit, please refer to the operating instructions attached with unit.

1. SPECIFICATIONS

TYPE two-speed, belt-driven, auto-
 matic return turntable
 SPEEDS 33 $\frac{1}{3}$ r.p.m., 45 r.p.m.
 PLATTER aluminum alloy die-cast
 diameter 300mm (12")
 MOTOR 4-pole synchronous
 WOW & FLUTTER 0.1% (W.R.M.S.)
 S/N RATIO 45dB
 TONEARM Statically balanced, S-shaped
 tubular
 TONEARM LENGTH 215mm (8 $\frac{1}{2}$ ")
 OVERHANG 10mm ($\frac{3}{8}$ ")
 STYLUS PRESSURE adjustable within 0~4g
 CARTRIDGE induced magnet type (SC-37)
 FREQUENCY RESPONSE .20~20,000Hz
 OUTPUT VOLTAGE 3.5mV per channel (1,000Hz
 50mm/sec.)
 LOAD IMPEDANCE 50k Ω
 TRACKING FORCE 2.5 \pm 0.4g
 STYLUS 0.5mil diamond (SN-37)
 POWER REQUIREMENTS .120V or 240V, 50Hz or 60Hz
 POWER CONSUMPTION .10W
 DIMENSIONS 442mm (17 $\frac{3}{16}$ ") W,
 166mm (6 $\frac{9}{16}$ ") H,
 352mm (13 $\frac{7}{8}$ ") D
 WEIGHT 6.7kg (14.7 lbs) net,
 9.0kg (19.8 lbs) packed

* Design and specifications subject to change without notice for improvements.

TABLE OF CONTENTS

<u>Section</u>	<u>Title</u>	<u>Page</u>
1.	SPECIFICATIONS	2
2.	OPERATION OF AUTO MECHANISM	3
3.	ADJUSTMENTS	3
3-1.	Adjusting the Auto Return	3
3-2.	Adjusting the Height of Tonearm Lifter	3
4.	PACKING LIST	4
5.	ACCESSORY PARTS LIST	4
6.	DISASSEMBLY WITH EXPLODED VIEWS, PARTS LOCATION AND PARTS LISTS	5

2. OPERATION OF AUTO MECHANISM

- 1) In case that tonearm is left off the arm rest, the PU plate will leave from micro-switch, then the turntable will be automatically switched ON so that the platter will start rotating.
- 2) At the moment when the stylus reaches lead-out groove, Auto-lever linked with PU plate starts pushing Reject-lever toward center of the platter.
- 3) As soon as the stylus reaches lead-out groove, turntable spindle gears into main-gear so that the main-gear starts rotating.
- 4) When the main gear starts rotating, the Auto-lever will be pushed outward by see-saw lever located under Return cam. Therefore, the tonearm will automatically return to arm rest.
- 5) While playing a disk, tonearm lifter keeps down gradually because the tip end of see-saw lever moves down in sloped concave A (See Fig. 2-1) on the backside of main gear. On the other hand, when the tonearm is on its rest, the lifter keeps up completely (6~12mm: space between record and stylus) because the tip end of see-saw lever is on the most shallow concave B.

3. ADJUSTMENTS

3-1. Adjusting the Auto Return

- 1) The adjusting screw in Fig. 3-1 is one to adjust the position of Auto Return when stylus reaches lead-out groove.
- 2) Make adjustment of the screw in such a way that stylus lifts up automatically around the middle way of lead-out groove. Namely turn the adjusting screw clockwise is for leading and counterclockwise is for lagging.
- 3) After adjusting the screw properly, check its operation a few times.
*Apply the locking paint in place to the screw after adjustment.

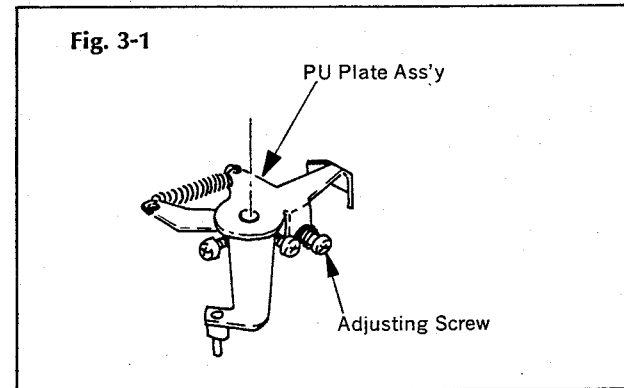

3-2. Adjusting the Height of Tonearm Lifter

- 1) The adjusting screw in Fig. 3-2 is one to adjust the height of tonearm lifter.
- 2) Place a disk (record) on turntable, then switch the tonearm lifter lever to PLAY. If stylus does not come down completely on a disk, turn the screw counterclockwise.
- 3) When tracing, switch tonearm lifter lever to LIFT. If the stylus does not lift up completely from a disk, turn the screw clockwise.
- 4) After adjustment of it, check its operation a few times.
*Apply the locking paint in place to the screw after adjustment.

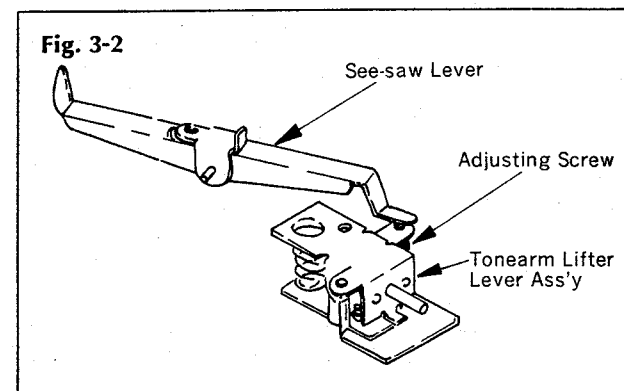

4. PACKING LIST

Parts No.	Stock No.	Description
1		Inner Packing
2	5502400	Turntable Rubber Mat
3	6112080	Platter
4	9022330	Stylofoam Packing (Upper)
5	5062210	Dust Cover
6	9022340	Stylofoam Packing (Bottom)
7	9002350	Carton Case

5. ACCESSORY PARTS LIST

Parts No.	Stock No.	Description
1	6642120	Head Shell Ass'y
2	9432011	Oil Feeder
3	6172060	45 r.p.m. Adaptor
4	6912310	Bias Weight
5	6912300	Main Weight
	9202190	Operating Instructions

*In SR-212E, Head Shell Ass'y of Parts No. 1 in the above list is not included.

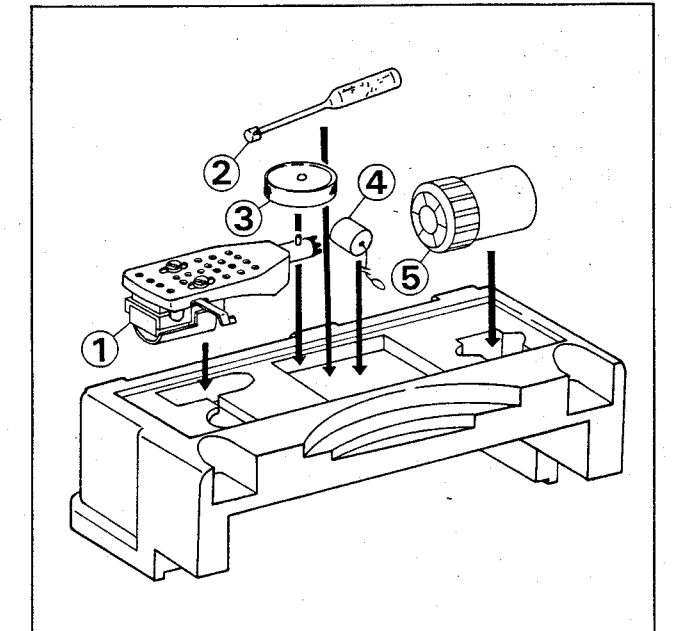
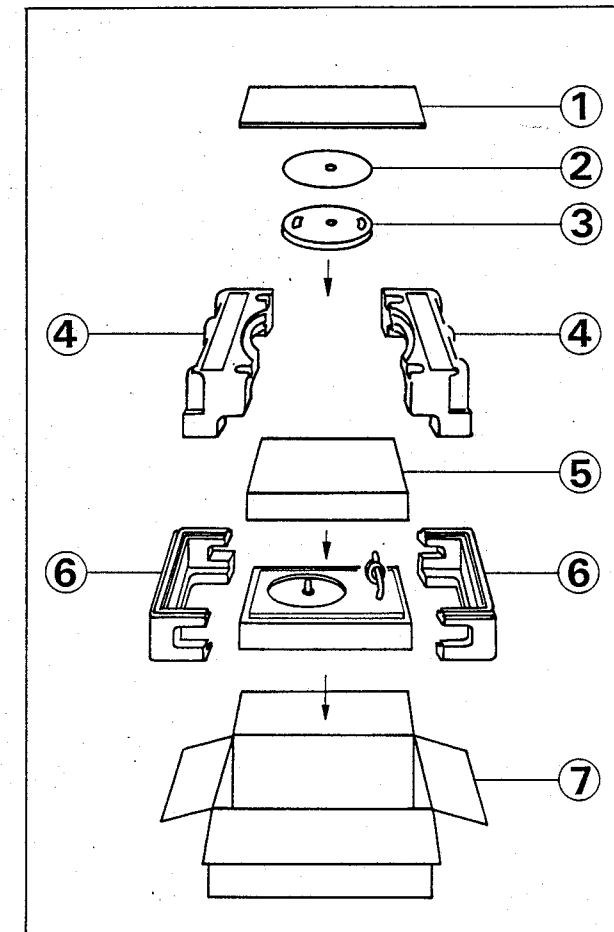

Parts No.	Stock No.	Description
108		Cord Stopper
109	3800230	Power Cord
110		Rear Panel
111	3810210	Output Cord
112	5140826	RH Type Screw, M3.1 × 13
113	2200390	Terminal Board Ass'y
114	5110241	Hex. Nut, M3
115	5121240	S Type Washer, 3φ
116	5512090	Insulator
117	5110241	Hex. Nut, M3
118	5121240	S Type Washer, 3φ
119	5512090	Insulator
120	5110241	Hex. Nut, M3
121	5121240	S Type Washer, 3φ
122	5512090	Insulator
123	5110241	Hex. Nut, M3
124	5121240	S Type Washer, 3φ
125	5512090	Insulator
126	5332022	Badge
127	5732310	Cabinet

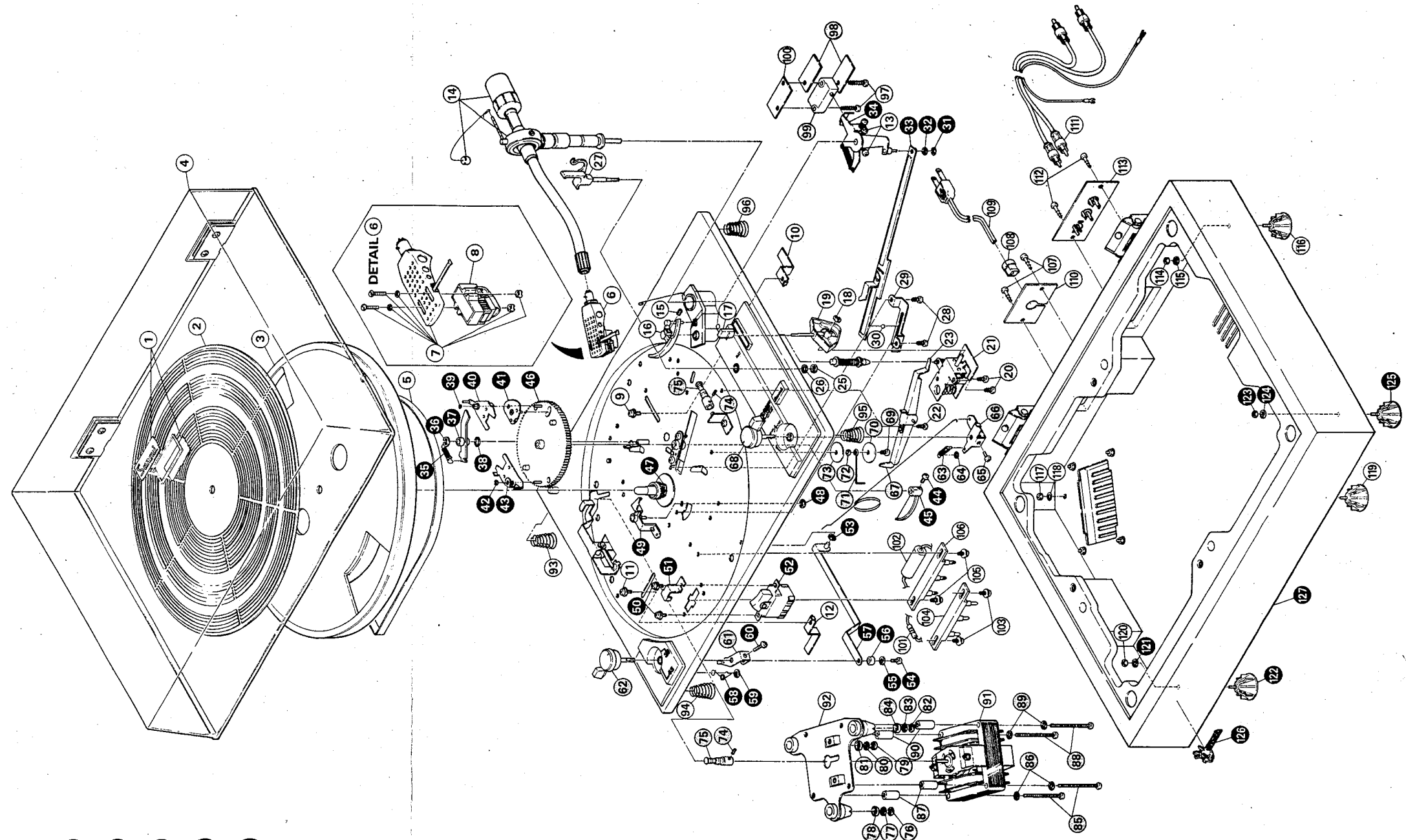

1. Pan Head Tapping Screw ... PT Type 	9. Flat Countersunk Wood Screw ... FC Type
2. Washer Head Tapping Screw ... WT Type 	10. Round Head Wood Screw ... RH Type
3. Pan Head Screw ... P Type 	11. Hex. Socket Setscrew ... SC Type
4. Pan Head SEMS A Screw ... PSA Type 	12. Slot Type Setscrew ... SS Type
5. Pan Head SEMS B Screw ... PSB Type 	13. Spring Washer ... S Type
6. Binding Head SEMS F Screw ... BSF Type 	14. Plain Washer ... P Type
7. Binding Head Screw ... B Type 	15. Retaining Ring (E Washer) ... E Type
8. Flat Countersunk Head Screw ... F Type 	

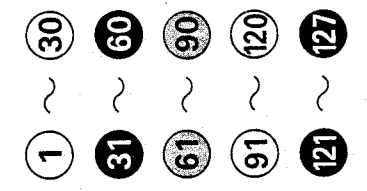

6. DISASSEMBLY WITH EXPLODED VIEWS, PARTS LOCATION AND PARTS LISTS

Parts List (※ : Differences between SR-212 and SR-212E)

Parts No.	Stock No.	Description	Parts No.	Stock No.	Description
1	5362380	Name Plate	※52	1120040	See-saw switch, voltage selector (SR-212)
2	5502400	Rubber Mat, turntable			Not Included in SR-212E
3	6112080	Turntable (Platter)	53	5151004	E Type Washer, 3φ
4	7012010	Dust Cover	54	5103521	PT Type Screw, M2.6 × 6
5	6032140	Drive Belt	55	5120141	P Type Washer, 3φ
※6	{ 6642120	Head Shell Ass'y (SR-212)	56	5232350	Spacer, linkage plate
		Not Included in SR-212E	57	6512110	Linkage Plate
7	6642080	Head Shell Sub Ass'y	58	6902770	Torsion Spring
※8	{ 4310220	Cartridge Ass'y (SR-212)	59		Circular External Ring, 3φ
		Not Included in SR-212E	60	5103044	P Type Screw, M3 × 8
	4310160	Cartridge (SC-37) (SR-212)	61	6502610	Lever, speed selector
	4940110	Stylus (SN-37) (SR-212)	62	5312170	Knob, speed selector
	5062250	Stylus Cover (SR-212)	63	6902830	Spring, cueing lever
9	5162391	PSA Type Screw, M3 × 8	64	5172120	Circular External Ring, 2φ
10		Lock Plate	65	5103044	P Type Screw, M3 × 8
11	5162391	PSA Type Screw, M3 × 8	66	6042030	Lever, cueing
12		Lock Plate	67	6902850	Linkage Wire, reject
13	5103044	P Type Screw, M3 × 8	68	5312180	Knob, cueing lever
14	7092260	Tonearm Ass'y	69	5103523	PT Type Screw, M2.6 × 10
15	5105642	SS Type Screw, M3 × 5	70	5182350	P Type Washer, 20 × 2.8 × 1.0
16	5292170	Guide, tonearm	71	6532120	Return Rod
17	5312160	Knob, tonearm lifter	72		Spacer, return rod
18	5151004	E Type Washer, 4φ	73	5182350	P Type Washer, 20 × 2.8 × 1.0
19	6012220	Cam, tonearm lifter	74	5105642	SS Type Screw, M3 × 5
20	5103542	PT Type Screw, M3 × 8	75	{ 6142230	Capstan (50Hz)
21	7052370	Lever Ass'y, tonearm lifter		{ 6142240	Capstan (60Hz)
22	5103542	PT Type Screw, M3 × 8	76	5151005	E Type Washer, 4φ
23	7052360	Lever, see-saw	77		P Type Washer, 4φ
24	7082120	Tonearm Lifter Ass'y	78	5262220	Cushion Holder
25	5110241	Hex. Nut, M3	79	5151005	E Type Washer, 4φ
26	5121240	S Type Washer, 3φ	80		P Type Washer, 4φ
27	6622170	Arm Rest Ass'y	81	5262220	Cushion Holder
28	5103542	PT Type Screw, M3 × 8	82	5151005	E Type Washer, 4φ
29	5212260	Holder, steel ball	83		P Type Washer, 4φ
30	6322010	Steel Ball	84	5262220	Cushion Holder
31	5151003	E Type Washer, 2.3φ	85	5103473	P Type Screw, M4 × 45
32	5120141	P Type Washer, 3φ	86	5121360	S Type Washer, 4φ
33	7052340	Auto Lever	87	5232290	Spacer, motor
34	7062190	PU Plate Ass'y	88	5103473	P Type Screw, M4 × 45
35	6902820	Spring, gear stopper	89	5121360	S Type Washer, 4φ
36	5151004	E Type Washer, 3φ	90	5232290	Spacer, motor
37	6402010	Gear Stopper	※91	{ 4320280	Motor (SR-212)
38		P Type Washer, 4φ		{ 4320270	Motor (SR-212E)
39	5151003	E Type Washer, 2.3φ	92	5202130	Motor Sheet
40	6422010	Auto Clutch	93	6902780	Cushion Spring A
41	6422030	Auto Trip	94	6902790	Cushion Spring B
42	5151003	E Type Washer, 3φ	95	6902800	Cushion Spring C
43	6422020	Manual Clutch	96	6902810	Cushion Spring D
44	5103044	P Type Screw, M3 × 8	97	5103525	PT Type Screw, M3 × 16
45	6012210	Cam, return	98	5622060	Insulator Plate
46	6002010	Main Gear	99	1160140	Micro Switch
47	7042050	Spindle Ass'y, turntable	100		Shield Plate
48	5151004	E Type Washer, 3φ	101	0111100	Solid Resistor 10Ω ½W
49	7052350	Lever, reject	102		Oil Capacitor 0.047μF 1500V
※50	{ 5103049	P Type Screw, M3 × 16 (SR-212)	103	5166461	WT Type Screw, M3 × 10
		Not Included in SR-212E	104		3P Terminal
※51	{ 5242460	Lock Bracket, voltage selector (SR-212)	105	5166461	WT Type Screw, M3 × 10
		Not Included in SR-212E	106		3P Terminal
			107	5140826	RH Type Screw, M3.1 × 13