



Service Manual

STEREO AMPLIFIER

SA-8800

ART-342 1005
S/M SA-8800
LIBR 1 INV: 31336264
MP: 3362-64

 **PIONEER**

MODEL SA-8800 COMES IN FIVE VERSIONS DISTINGUISHED AS FOLLOWS:

Type	Voltage	Remarks
KU	120V only	U.S.A. model
KC	120V only	Canada model
HG	220V and 240V (Switchable)	Europe or Oceania model
S/G	110V, 120V, 220V and 240V (Switchable)	U.S. Military model
S	110V, 120V, 220V and 240V (Switchable)	General export model

The variation in safety standards in different countries has also necessitated variations in power supply and circuit component specifications.

This service manual is applicable to the KU type. For servicing of the other types please refer to the additional service manuals.

CONTENTS

1. SPECIFICATIONS	3	11.11 Indicator Assembly (AWV-001)	39
2. FRONT PANEL FACILITIES	4	11.12 Phones Jack Assembly (GWX-244)	41
3. REAR PANEL FACILITIES	7	11.13 Power Supply Assembly (AWR-182)	42
4. BLOCK DIAGRAM	8		
5. CIRCUIT DESCRIPTIONS			
5.1 Pre-Amplifier Section	8		
5.2 Power Amplifier Section	10		
5.3 Indicator Circuit	13		
5.4 Protection Circuit	14		
6. DISASSEMBLY	15		
7. PARTS LOCATION	16		
8. PACKING	18		
9. ADJUSTMENTS	19		
10. EXPLODED VIEW	20		
11. SCHEMATIC DIAGRAMS, P.C. BOARD PATTERNS AND PARTS LIST			
11.1 Miscellanea	23		
11.2 Schematic Diagram	24		
11.3 P.C. Boards Connection Diagram	27		
11.4 Terminal Assembly (GWX-242)	31		
11.5 Switch Assembly (AWS-134)	31		
11.6 EQ Assembly (GWF-113)	32		
11.7 Filter Assembly (GWS-164)	33		
11.8 TC Assembly (GWG-122)	34		
11.9 VR Assembly (GWX-243)	35		
11.10 PA Assembly (GWH-115)	36		

1. SPECIFICATIONS

Semiconductors

ICs	3
FETs	6
Transistors	73
Diodes	49
Others	2

Power Amplifier Section

Continuous Power Output is 80watts* per channel, min., at 8 ohms from 10 Hertz to 20,000 Hertz with no more than 0.005% total harmonic distortion, or 80 watts* per channel at 4 ohms from 10 Hertz to 20,000 Hertz with no more than 0.005% total harmonic distortion.

Continuous Power Output

10Hz to 50,000Hz: 80W + 80W (T.H.D. 0.01%, 8 ohms)
100W + 100W (T.H.D. 0.02%, 4 ohms)

Total Harmonic Distortion (10 Hertz to 20,000 Hertz)

continuous rated power output	No more than 0.005%
-------------------------------	---------------------

40 watts per channel power output, 8 ohms	No more than 0.004%
--	---------------------

1 watt per channel power output, 8 ohms	No more than 0.004%
--	---------------------

Intermodulation Distortion (50 Hertz : 7,000 Hertz = 4 : 1)

continuous rated power output	No more than 0.002%
-------------------------------	---------------------

40 watts per channel power output, 8 ohms	No more than 0.002%
--	---------------------

1 watt per channel power output, 8 ohms	No more than 0.002%
--	---------------------

Frequency Response

5 to 200,000 Hertz ± 0.2 dB (POWER AMP IN)

Input (Sensitivity/Impedance)

1V/50 kilohms (POWER AMP IN)

Output

Speaker	A, B, A+B
Headphones	Low impedance

Damping Factor

(20 Hertz to 20,000 Hertz, 8 ohms)	55
------------------------------------	----

Hum and Noise

(IHF, short-circuited, A network)	118dB
-----------------------------------	-------

Preamplifier Section

Input Sensitivity/Impedance

PHONO 1	2.5 mV/50
PHONO 2	2.5 mV/50

CARTRIDGE LOAD

Both Phono 1 and 2
100, 10k, 25k, 50k, 100k ohms
100, 200, 300, 400, 500pF

TUNER

150mV/50 kilohms

AUX

150mV/50 kilohms

TAPE PLAY 1

150mV/50 kilohms

TAPE PLAY 2

150mV/50 kilohms

Phono Overload Level (T.H.D. 0.002%, 1 kHz)

PHONO 1, 2	250mV
------------	-------

Output (Level/Impedance)

TAPE REC 1	150mV
TAPE REC 2	150mV
PRE OUT	1V/600 ohms, 3V/600 ohms (max.)

Total Harmonic Distortion

(10 to 50,000 Hertz, 1V output) : No more than 0.006%

Frequency Response

PHONO (RIAA Equalization)	20Hz to 20,000Hz ± 0.2 dB
TUNER, AUX, TAPE PLAY	5Hz to 100,000Hz ± 1 dB

Tone Control

BASS	+10dB, -10dB (100Hz)
TREBLE	+10dB, -10dB (10kHz)

Filter SUBSONIC

15Hz (6dB/oct)	
HIGH	8kHz (6dB/oct)

Hum and Noise (IHF, short-circuited, A network)

PHONO	90dB
TUNER, AUX, TAPE PLAY	110dB

Muting

-20dB	
Loudness Contour (Volume control set at -40dB position)	+6dB (100Hz), +3dB (10kHz)

Miscellaneous

Power Requirements	120V, 60Hz
Power Consumption	260W (UL), 500VA (CSA)
Dimensions	453(W) x 155(H) x 425(D) mm 17-11/16(W) x 6-1/8(H) x 16-3/4(D) in
Weight Without package	15.6kg (34 lb 6 oz)

Furnished Parts

Operating instructions	1
------------------------	---

* Measured pursuant to Federal Trade Commission's Trade Regulation rule on Power Output Claims for Amplifier.

NOTE:
Specifications and the design subject to possible modification without notice due to improvements.

2. FRONT PANEL FACILITIES

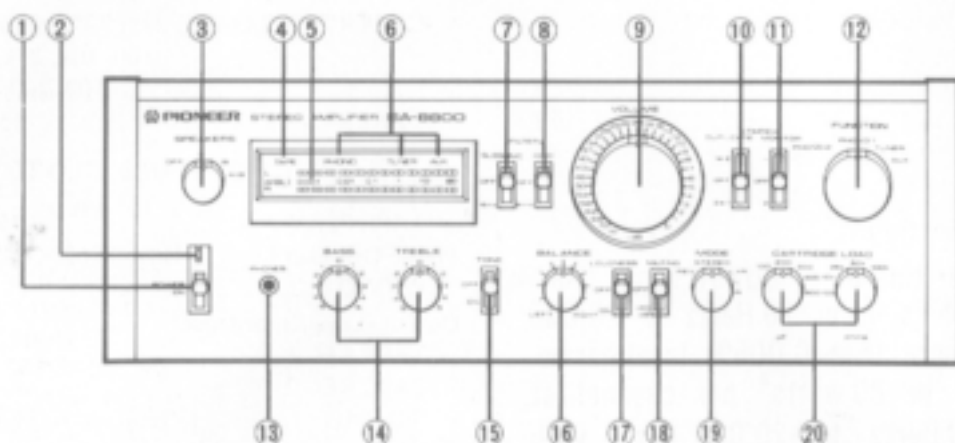

① POWER SWITCH

Set this switch to ON to supply power to the amplifier. There will be a short delay when it is set to ON, because the muting circuit has been actuated to suppress the unpleasant noise that is sometimes generated when the power is on and off.

② POWER INDICATOR

When the power switch is set to ON this lamp lights up, indicating the amplifier is turned on.

③ SPEAKER SELECTOR

Use this selector to select the speaker system.

OFF: Sound not obtained from speakers.

A: Sound obtained from speakers connected to the A speaker terminals.

B: Sound obtained from speakers connected to the B speaker terminals.

A+B: Sound obtained from speakers connected to both A and B speaker terminals.

④ TAPE MONITOR INDICATOR

The TAPE lamp lights up when the tape monitor switch is set to either position "1" or "2".

⑤ POWER METER

This meter allows you to read out the rated power level on the fluorescent display tube when speakers with a nominal impedance of 8 ohms are connected to the amplifier's speaker terminals.

⑥ FUNCTION INDICATORS

The PHONO, TUNER, AUX function indicators light up in accordance with the position of the function selector.

NOTE:

The function indicator will not go off when the tape monitor switch is set to position "1" or "2". This indicates a program at the recording source end during the monitoring of a recording.

⑦ SUBSONIC FILTER SWITCH

When this switch is set to the 15Hz position, the subsonic filter with a cut-off frequency of 15Hz is actuated. The subsonic filter serves to attenuate frequencies lower than 15Hz in a 6dB/oct slope. It is therefore effective in suppressing ultra-low-frequency noise which is generated by record warp and other causes. You cannot actually hear this noise but it is a factor in the generation of intermodulation distortion and it may damage your speaker system. Set this switch to the 15Hz position during record play for the best effect.

⑧ HIGH FILTER SWITCH

The high filter with a cut-off frequency of 8kHz is actuated when this switch is set to the 8kHz position.

The high filter serves to attenuate frequencies higher than 8kHz in a 6dB/oct slope. This is why it is effective in suppressing high-frequency noise or noise from scratches on records being played.

⑨ VOLUME CONTROL

Use this control to adjust the output level to the speakers and headphones. Turn it clockwise to increase the output level. No sound will be heard if you set it to ∞. The scale is graduated in dB which indicate the attenuation when the maximum output level is 0dB.

⑩ TAPE DUPLICATE SWITCH

Use this switch when employing two tape decks to duplicate recorded tapes or edit tapes. This switch is otherwise kept at the OFF position.

1 ▶ 2: When playing back the tape on a deck connected to the TAPE 1 jacks and recording (duplicating) on a deck connected to the TAPE 2 jacks.

OFF: Set to this position when not duplicating.

2 ▶ 1: When playing back the tape on a deck connected to the TAPE 2 jacks and recording (duplicating) on a deck connected to the TAPE 1 jacks.

⑪ TAPE MONITOR SWITCH

Use this switch to select the program source which is being reproduced.

1: Set here to monitor a recording or a tape being played back on a tape deck which is connected to the TAPE 1 jacks.

OFF: Set here whenever you are not playing back a tape or monitoring a recording (i.e. when you have set the function selector to PHONO 1, PHONO 2 or TUNER, or AUX for an alternative program source).

2: Set here to monitor a recording or a tape being played back on a tape deck which is connected to the TAPE 2 jacks.

⑫ FUNCTION SELECTOR

Use this selector to select the program source. When set, the function indicator above the meter panel corresponding to the position of the function selector will light up.

PHONO 2: Set here when playing records on a turntable connected to the PHONO 2 jacks. (The PHONO function indicator lights up.)

PHONO 1: Set here when playing records on a turntable connected to the PHONO 1 jacks. (The PHONO function indicator lights up.)

TUNER: Set here when listening to broadcasts on a tuner connected to the TUNER jacks. (The TUNER function indicator lights up.)

AUX: Set here when listening to a program source which is connected to the AUX jacks. (The AUX function indicator lights up.)

⑬ HEADPHONE JACK

Plug the headphones into this jack when you want to listen through your stereo headphones.

NOTE:

Set the speaker selector to OFF when listening only with headphones.

⑭ BASS AND TREBLE CONTROLS

Use these controls to adjust the bass and the treble. If you set the tone switch to ON and turn the bass control to right from its center position, you will be able to emphasize the sound in the low-frequency range. Conversely, turning the bass control to the left from the center position, you will attenuate the sound.

You can use the treble control to adjust the sound in the high-frequency range.

⑮ TONE SWITCH

Set this switch to ON when adjusting the bass and treble controls. When set to OFF, the tone control circuits are disengaged and frequency response is flat. This function is convenient for checking phono cartridge and speaker tone quality and listening room acoustics.

⑯ BALANCE CONTROL

Use this control to balance the volume of the left and right channels. First, however, set the mode selector to mono (L+R, L, or R), and adjust so that the sound appears to come from somewhere exactly between the two speakers. If the sound appears to be louder on the right, it means that the volume of the right channel is higher. Turn the balance control to the left and adjust.

Conversely, if the sound appears to be louder on the left, it means that the volume of the left channel is higher. Therefore, turn the balance control to the right and adjust. After adjusting, return the mode selector to STEREO.

⑰ LOUDNESS SWITCH

When listening to a performance with the volume control turned down, set this switch to ON and the bass and treble will be accentuated.

When the volume is low, the human ear finds it harder to hear the bass and treble than when the volume is high. The loudness switch is thus designed to compensate for this deficiency. By setting it to ON, the bass and treble come through much more strongly and the sound takes on a punch even when the volume control is turned down.

18 MUTING SWITCH

Set this switch to -20dB to attenuate the audio output indicated by the volume control by 20dB . There is no need to adjust the volume control if you use this switch when turning down the audio output temporarily and when changing over records or tapes.

19 MODE SELECTOR

Use this selector for selecting the performances.

REV: Reverses left and right channel stereo signals and reproduces them stereophonically.

STEREO: Set to this position for normal stereo reproduction.

L+R: Mixes left and right channel signals and reproduces them monophonically.

L: Left channels signal is reproduced monophonically from both speakers.

R: Right channel signal is reproduced monophonically from both speakers.

20 CARTRIDGE LOAD SELECTORS (ohms and pF)

These selectors allow you to select the input resistance and input capacitance in line with the rated load impedance and load capacitance of a moving magnet (MM) cartridge for record play.

Use these two switches to produce the sound quality of your preference or the ideal conditions for your cartridge.

VOLUME CONTROL AND MUTING SWITCH

The volume control scale is directly calibrated in dB. By adjusting it in combination with the muting switch, it is possible to adjust the attenuation more finely across a very wide range. The attenuation (volume) is equal to the volume control indication plus 20dB .

- There will be no need to adjust the volume control every time you change over a tape or record if you set the switch to -20dB position for reducing the volume temporarily during play.
- You will not be able to finely adjust the volume if the volume control is near the ∞ position when listening to a program at a low sound level at night, for example. In such cases, set the muting switch to -20dB and you will then be able to adjust the sound with the volume control to more fine steps.

NOTE:

Always turn the volume control right down when returning the muting switch to OFF during a performance when the sound is set to a high level with the volume control.

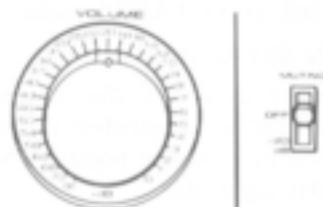

3. REAR PANEL FACILITIES

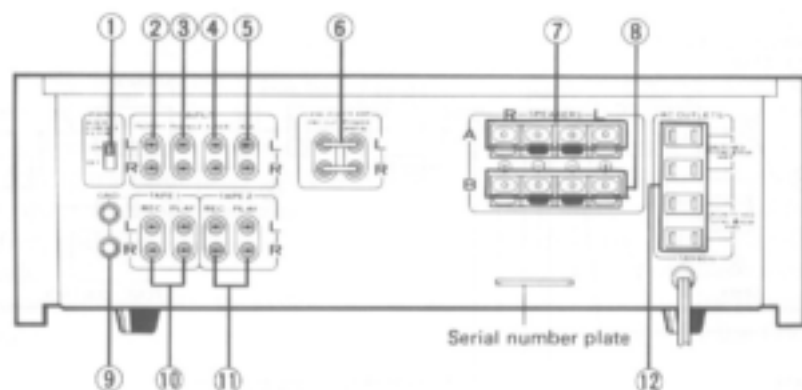

① PHONO INTERFERENCE FILTER SWITCH

This is used to attenuate radio-frequency interference from external electronic or electrical appliances or products during record play.

When this switch is set to ON during record play with the cartridge load resistance switch is at 100Ω position, the sound volume will be reduced.

② PHONO 1 JACKS

Connect the turntable output cords to these jacks.

③ PHONO 2 JACKS

Connect your second turntable output cords to these jacks.

④ TUNER JACKS

Connect the tuner cords to these jacks.

⑤ AUX JACKS

These are auxiliary input jacks. Connect a TV tuner or cartridge tape player to them.

⑥ PREAMPLIFIER/POWER AMPLIFIER CONNECTOR BAR

When this connector bar is disconnected from the jacks, you can separate the SA-8800's preamplifier and power amplifier. For normal use, however, it is connected.

NOTE:

If this bar is not connected properly, you will not hear any sound from the speakers connected to the SPEAKERS terminals.

⑦ SPEAKERS TERMINALS A

Connect your first pair of speakers to these terminals.

⑧ SPEAKERS TERMINALS B

Connect your second pair of speakers to these terminals.

⑨ GND TERMINALS

These are the ground terminals. Connect the ground wire of the turntable, etc. to these terminals.

⑩ TAPE 1 JACKS

Connect the tape deck cords to these jacks. Connect the REC (recording) jacks to the INPUT jacks on the tape deck, and the PLAY (playback) jacks to the OUTPUT jacks.

⑪ TAPE 2 JACKS

Connect your second tape deck cords to these jacks. Connect the REC (recording) jacks to the INPUT jacks on the tape deck, and the PLAY (playback) jacks to the OUTPUT jacks.

⑫ AC OUTLETS

These are spare power outlets. Insert the power plug on the stereo components (turntable, tuner, tape deck, etc.) into these outlets.

SWITCHED: The power supplied through these outlets is coupled to the operation of the amplifier's power switch. The maximum power capacity which may be connected to the two SWITCHED outlets is 200W (For the Canadian model, the maximum power capacity is 100VA).

UNSWITCHED: The power is always supplied through these two outlets regardless of the position of the power switch. The maximum power capacity which may be connected to these two outlets is 200W (For the Canadian model, the maximum power capacity is 100 VA).

4. BLOCK DIAGRAM

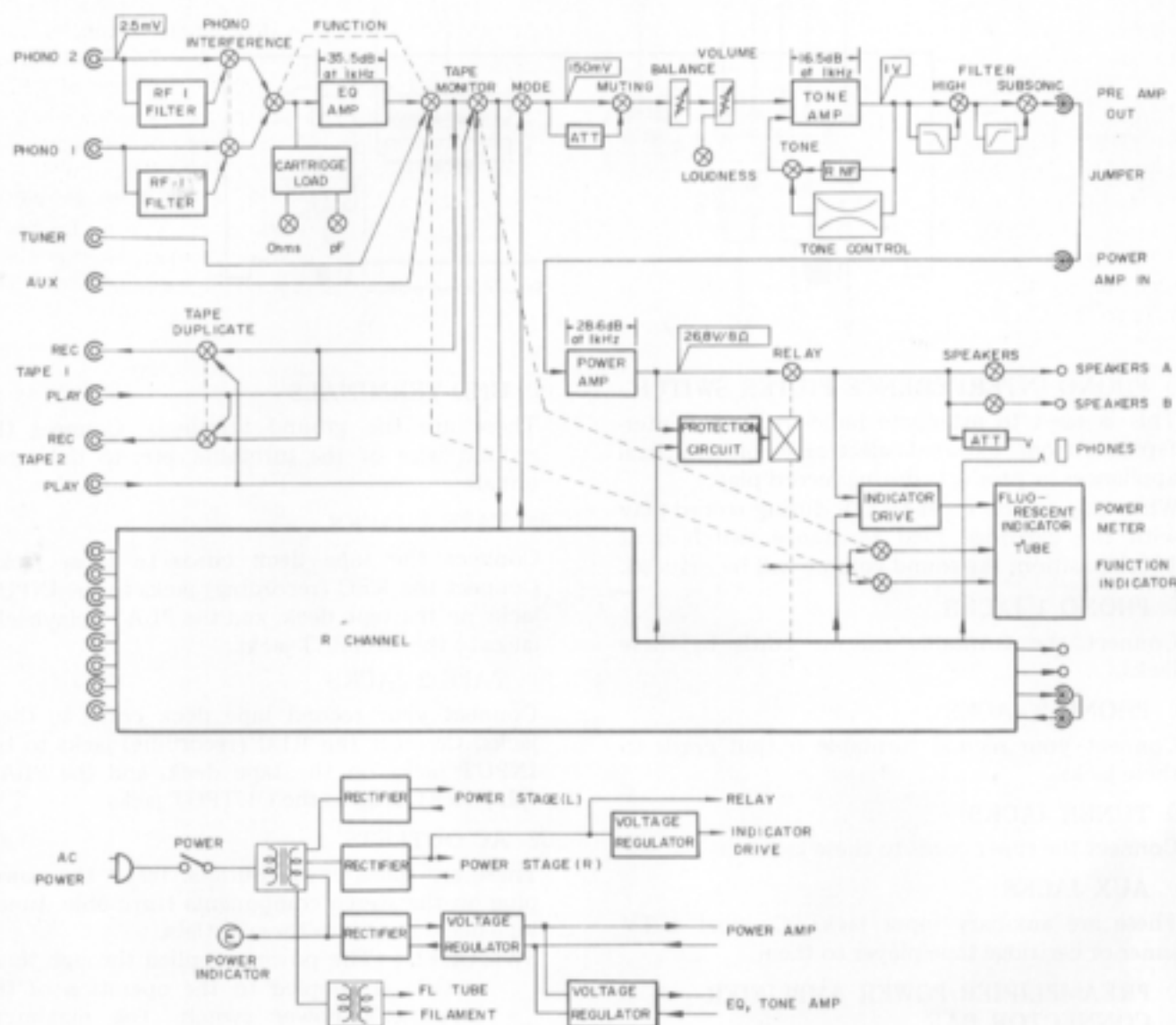

5. CIRCUIT DESCRIPTIONS

5.1 PRE-AMPLIFIER SECTION

Cartridge Load Selectors

The input resistance and input capacitance of the PHONO input may be varied. The EQ amplifier input resistance is set to $100k\Omega$, and the input capacitance to $100pF$. By operation of the CARTRIDGE LOAD selectors, different resistors and capacitors will be in parallel with the PHONO input circuit. Five different input resistance levels (100Ω , $10k\Omega$, $30k\Omega$, $50k\Omega$ and $100k\Omega$) and five different input capacitance levels ($100pF$, $200pF$,

$300pF$, $400pF$ and $500pF$) are available, permitting the user to select optimum load conditions for the phono cartridge being employed in the turntable connected to the PHONO terminals.

Phono Interference Filter

Because of the high sensitivity of the phono input circuits, a certain amount of radio frequency interference may occur. This may be reduced by simply turning the rear panel PHONO INTERFERENCE FILTER on (thereby connecting a resistor in series with the phono input circuits).

EQ Amplifier

Fig. 5-1 shows the basic configuration of the circuit. The EQ amplifier is a completely symmetrical DC-coupled 3-stage amplifier, the first stage of which employs newly developed ultra-low-noise NPN and PNP transistors.

The output stage is a symmetrical complementary SEPP Class A configuration. The output current is of the same order of magnitude as that of a small power amplifier, and is sufficient to cope with low-impedance loads.

The resultant S-N ratio of the EQ amplifier is 90dB, while the equalizer deviation is $\pm 0.2\text{dB}$ (20Hz to 20,000Hz).

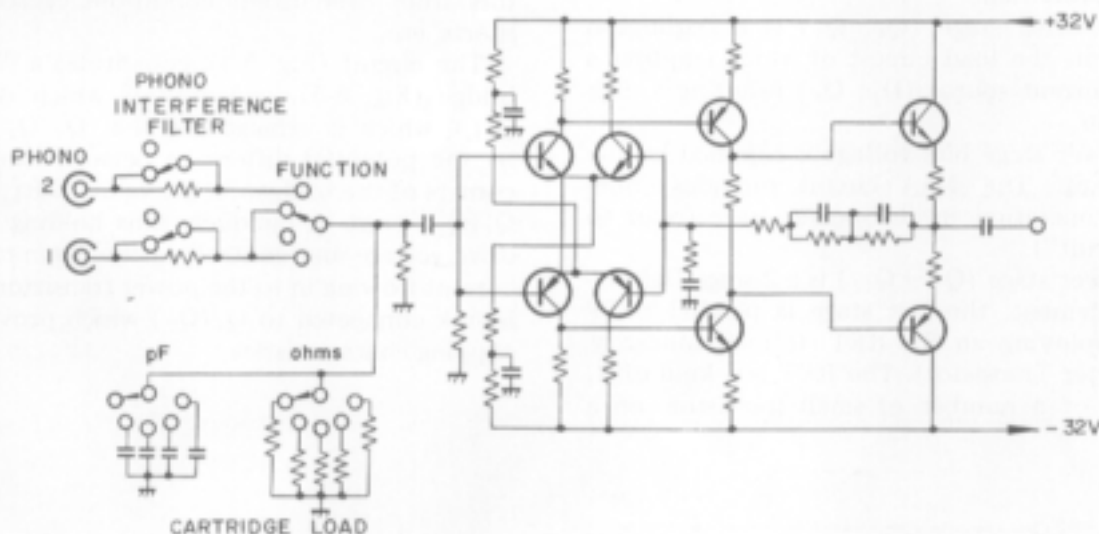

Fig. 5-1 EQ Amplifier

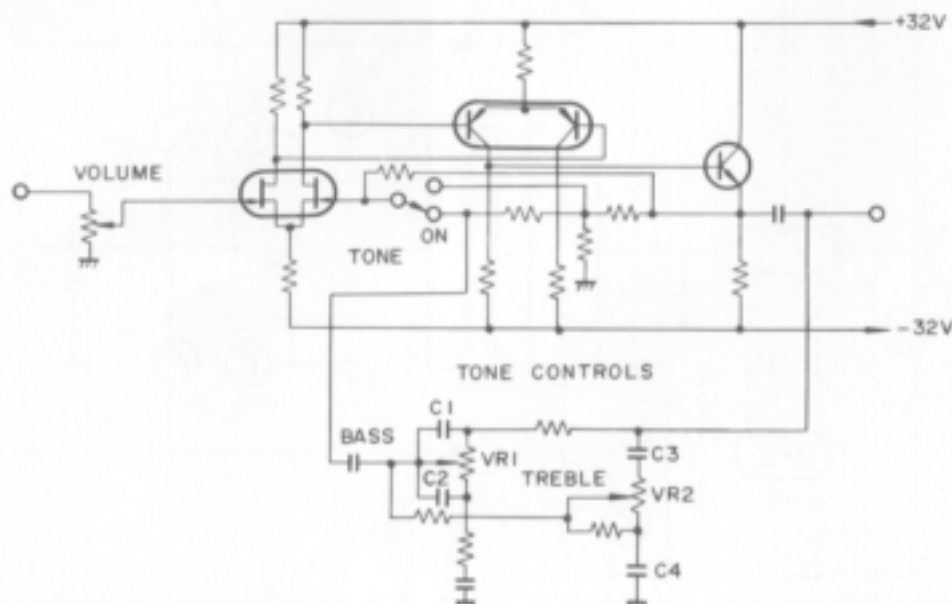

Fig. 5-2 Tone Control Circuit

Tone Controls

Fig. 5-2 shows the basic tone control circuit. The tone amplifier is a 3-stage DC-coupled amplifier, the first stage is a differential amplifier consisting of a ultra-low-noise twin FET. The second stage is a differential amplifier consisting of a PNP twin transistor, and the output impedance lowered by using an emitter follower at the output stage.

Tone control (BASS, TREBLE) is accomplished by providing the tone amplifier NFB circuit with a frequency selective characteristic. The NFB circuit is changed to a flat frequency characteristic when the TONE switch is in the OFF position.

5.2 POWER AMPLIFIER SECTION

Amplifier Circuit

The basic circuit arrangement of the power amplifier is shown in Fig. 5-3. The first stage is a differential amplifier comprising PNP twin transistor (Q_2), the load circuit of which is a current mirror employing an NPN twin transistor (Q_3). The current mirror provides push-pull operation in this stage, which serves to cancel even harmonics and further increase gain.

Q_1 in the input circuit absorbs outflow of base current from Q_2 , and prevents the generation of a DC voltage. Because Q_1 follows any temperature drift in Q_2 , temperature drift of the center point voltage is prevented.

The pre-drive stage (Q_4, Q_5) is a Darlington arrangement, the load circuit of which employs a constant-current source (D_1, Q_6) resulting a high voltage gain.

The power stage bias voltage is supplied by the NSA circuit. The NSA circuit provides non-switching operation in the power stage (refer to "NSA Circuit").

The power stage ($Q_7 - Q_{12}$) is a 2-stage Darlington arrangement, the last stage is parallel SEPP circuit employing an SL RET (Super Linearity Ring Emitter Transistor). The RET is a kind of IC consisting of a number of small transistors on a

single chip, with each transistor being connected in parallel via an emitter resistor. This provides excellent high frequency characteristics comparable to those of a small-signal transistor. Furthermore, because there is no time constant in the NFB circuit in the low-frequency region, amplification is possible down to DC (DC inputs will be cut off, however, by the input coupling capacitor).

The circuit features described above provide an extremely wide power frequency range (80W + 80W, 10Hz to 20kHz, THD 0.005%, 8 Ω).

Power Limiter

The power limiter is a high-speed protection circuit which operates to protect the power transistors from overcurrent conditions caused by load shorts, etc.

The circuit (Fig. 5-4), constitutes a Wheatstone bridge (Fig. 5-5), one arm of which is the load (R_L), which is arranged so that $Q_1(Q_2)$ is biased by the potential difference between the opposite corners of the bridge. As the value of R_L decreases, $Q_1(Q_2)$ start to conduct, thus holding down the drive voltage and controlling the magnitude of the current flowing in to the power transistors. $Q_3(Q_4)$ is link connected to $Q_1(Q_2)$ which provides sharp clipping characteristics.

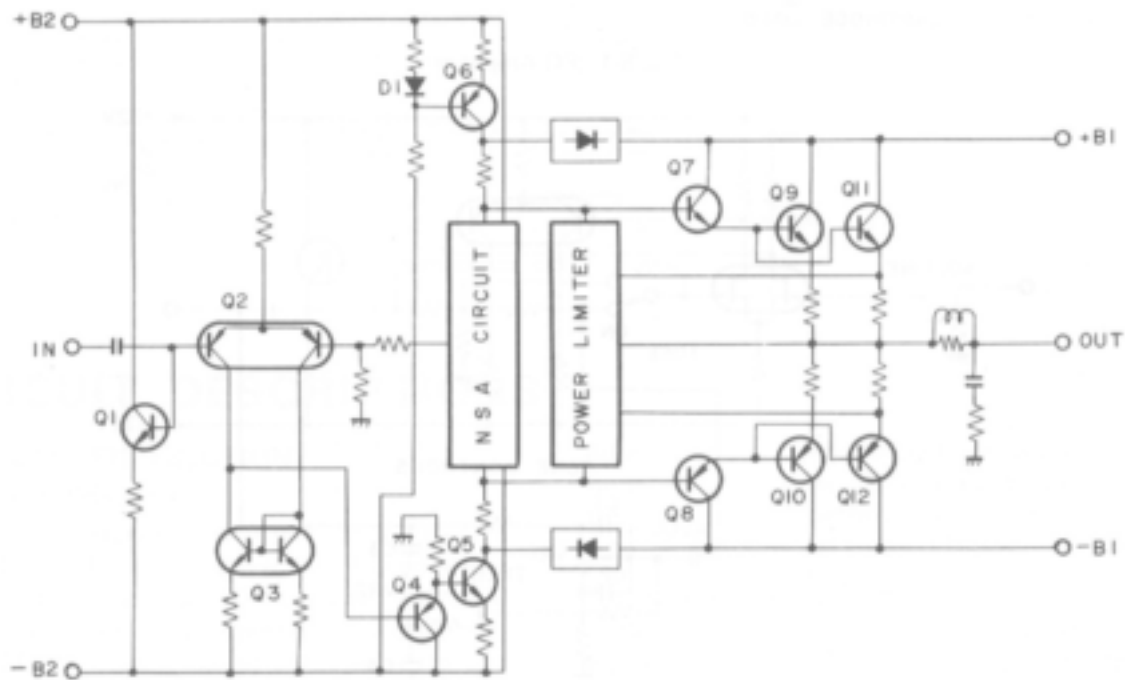

Fig. 5-3 Power amplifier circuit

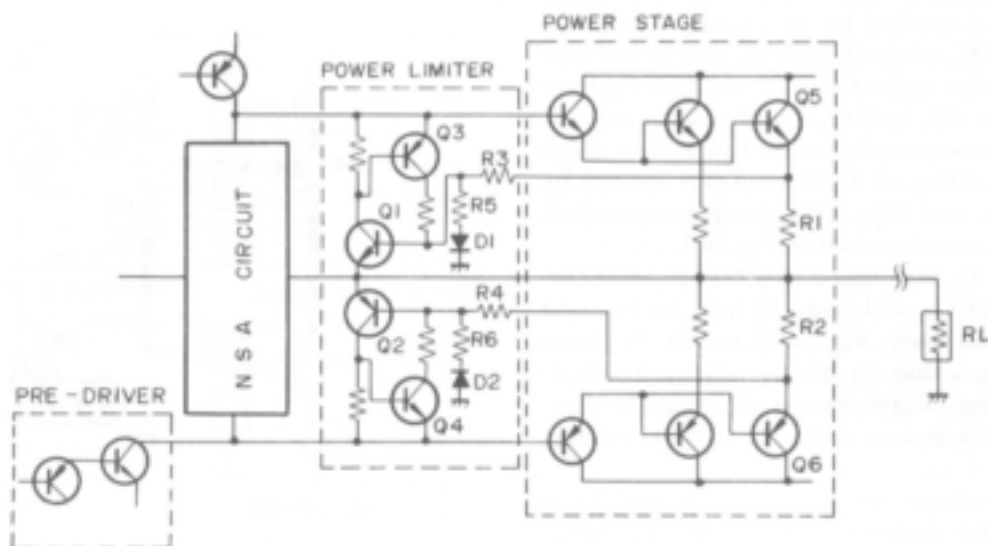

Fig. 5-4 Power Limiter Circuit

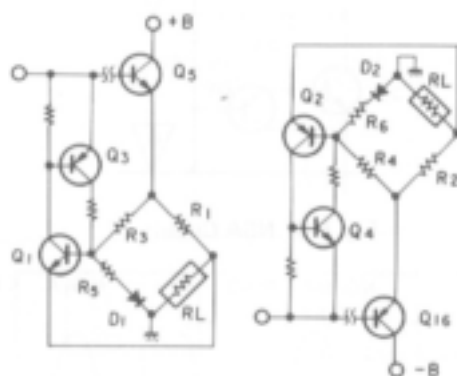

Fig. 5-5 Bridge Circuit

NSA (Non-Switching Amplifier) Circuit

By operating the power stage only within the active region (no possible cut-off) and with minimum idle current, the NSA circuit prevents the generation of switching distortion and reduces heat loss.

Operating Principle

Since idle current flows through normal class B SEPP power stages (see Fig. 5-6) when no signal is applied, the DC level is shifted by D and VR by a fixed amount (with the voltage across points P and R serving as a bias). The voltages across points P and Q, and Q and R at this time will be equal. When the positive portion of a signal is applied to this circuit, the power stage current on the NPN

side is increased resulting in the voltage across points P and Q also being increased. However, since the voltage across points P and R is practically constant (see note), the voltage across points P and R (PNP power stage bias) will be decreased, resulting in the PNP power stage being cut off.

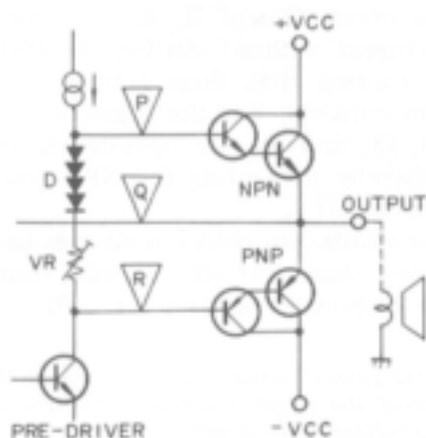

Fig. 5-6 Normal Power Stage

The NSA circuit increases the voltage across points P and R by the same amount as the voltage increase across points P and Q, thereby cancelling the voltage decrease across points Q and R, and preventing the PNP power stage from being cut off.

This NSA circuit is outlined in Fig. 5-7. When there is no signal applied to the circuit, Q_1 and Q_2 are almost cut off, while Q_3 and Q_4 will be on. The voltage across the collector and base of both of these transistors (Q_3 and Q_4) at this time may be disregarded. Consequently, with the power stage bias circuit consisting of 4 PN junctions formed by Q_3 , D_3 , and Q_4 , and VR_1 , this circuit is equivalent to the previous circuit shown in Fig. 5-6.

With R_1 and D_3 ensuring a constant flow of current, the base of Q_1 and point Q may be brought to the same level (see Fig. 5-8) on an AC basis (level fluctuations due to the signal) by a simple shift in DC level. Furthermore, Q_1 may be considered emitter-follower with R_3 as the emitter resistance.

When the voltage across points P and Q is increased by the positive portion of the signal applied to this circuit, it becomes the input signal of this emitter-follower (Q_1). Since the emitter-follower voltage gain is practically 1, a voltage more or less equal to that of the input signal (that is, the voltage increase across points P and Q) is produced at R_3 . And the R_3 voltage is the voltage applied across the base and collector of Q_3 which forms part of the power stage bias circuit. So the bias voltage applied to Q_3 will be in excess by the same amount that the voltage across points P and Q is increased (by positive portion of the signal) above the voltage level when no signal is being applied. Consequently, the increase in voltage across points P and Q cancels the decrease in voltage across points Q and R, thereby maintaining the idle current without cutting the PNP power stage off (noting that there actually is a slight decrease in current). For the negative portions of the signal, Q_3 and Q_4 are operated in the same manner, thereby preventing the NPN power stage from being cut off.

In other words, the NSA circuit acts to prevent any "power stage cut-off" signals from being applied to the power stage (see Fig. 5-9).

Note:

The pre-driver current actually decreases when the positive portion of the signal is applied, resulting in a decrease in the voltage across points P and R.

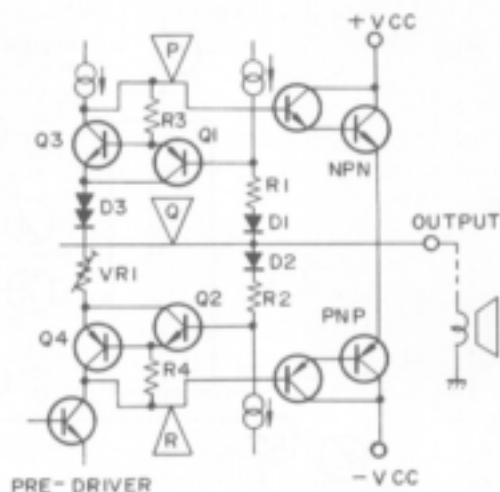

Fig. 5-7 NSA Circuit

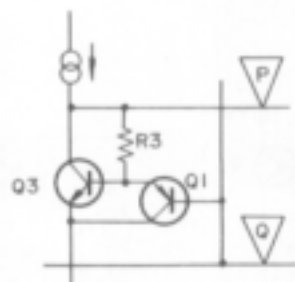

Fig. 5-8 NSA Circuit

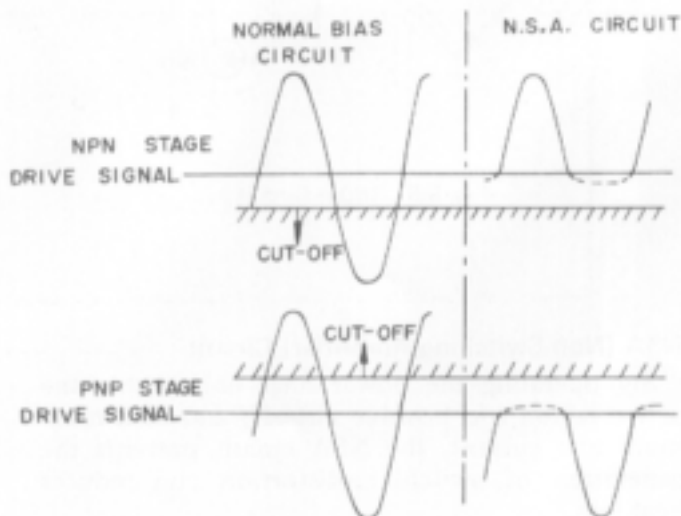

Fig. 5-9 Driving Signal of Power Stage

5.4 PROTECTION CIRCUIT

The purpose of this circuit is to protect the speakers. The relay in the output circuit is automatically opened in any of the following cases:

1. During the "transient operations" when the power supply is turned on and off.
2. Upon detection of a DC voltage in the output circuit, caused by component failure or accident.

Muting Operation when Power Supply is Turned On and Off

With reference to Fig. 5-11 when the power supply is turned on, Q_1 turns off due to $-B_1$ (The time constant of the $-B_1$ circuit is very small.). If there is no input (DC) on Q_3 and Q_4 , they will be off, and the timing capacitor C_{24} charges up through R_7 and R_{12} , and thus Q_2 turns on. When Q_2 conducts, the relay operates, and the output muting on the power amplifier will be removed.

When the power supply is turned off, $-B_1$ will abruptly decay, and Q_1 will conduct owing to the residual component of $+B_1$. As a result, C_{24} will rapidly discharge, Q_2 will cease to conduct, whereupon the relay will become de-energized and restore muting.

DC Voltage Detector

The output circuit is connected to the Q_3 emitter and Q_4 base via a low-pass filter (R_{13} , C_{25}). Any DC voltages appearing the output circuit of the power amplifier, it will be applied to the Q_3 emitter and the Q_4 base. If the voltage is positive, Q_4 turns on. C_{24} will rapidly discharge. If the voltage is positive, Q_4 turns on. C_{24} will rapidly discharge. As consequence, Q_2 will turn on and the relay will become de-energized, thus causing the output circuit to open.

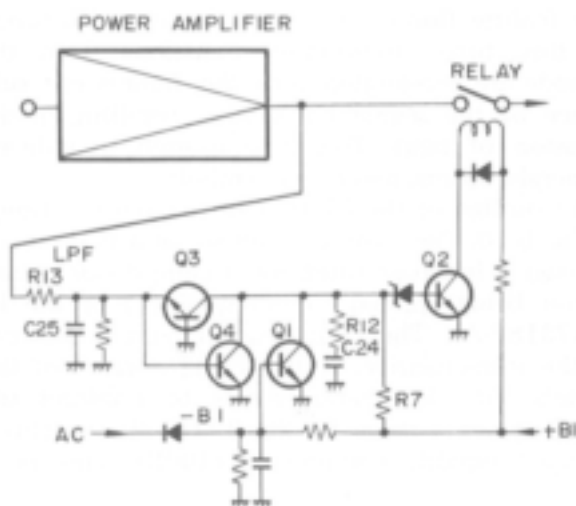

Fig. 5-11 Protection Circuit

6. DISASSEMBLY

Wooden Cover

Remove the two screws on each side of the wooden cover.

Bottom Plate

Remove the nine screws to detach the bottom plate.

Front Panel

Loosen the set screws of VOLUME knob with a hexagonal wrench. Remove all the knobs by pulling. Remove the three screws from the top edge of the front panel. Remove the two nuts from the control shafts.

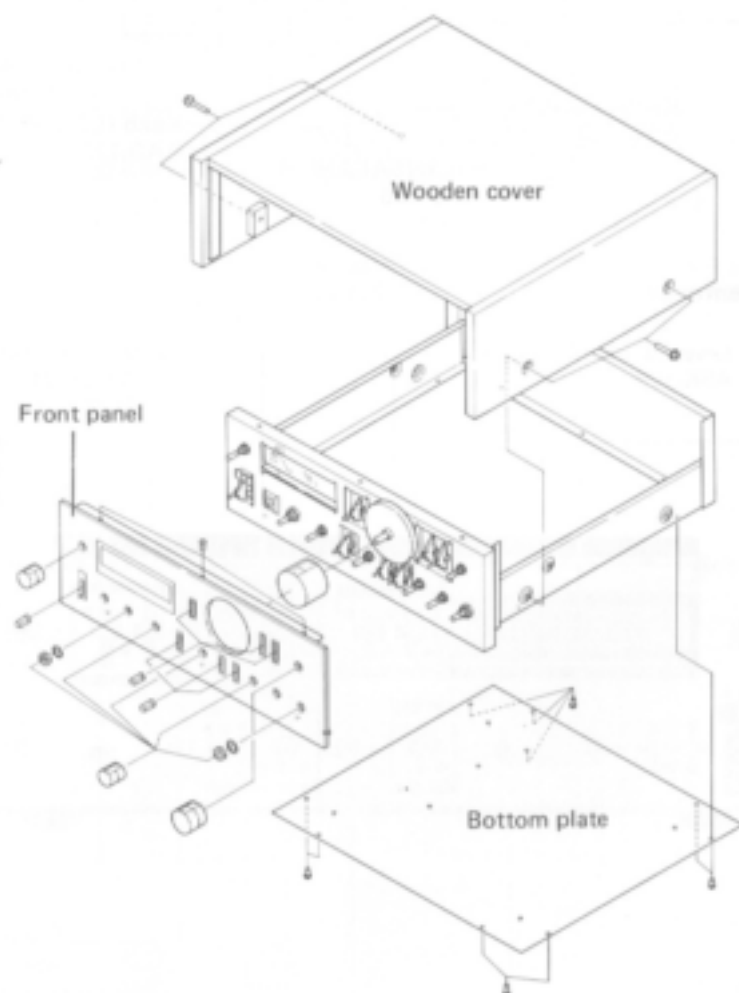

7. PARTS LOCATION

Front Panel View

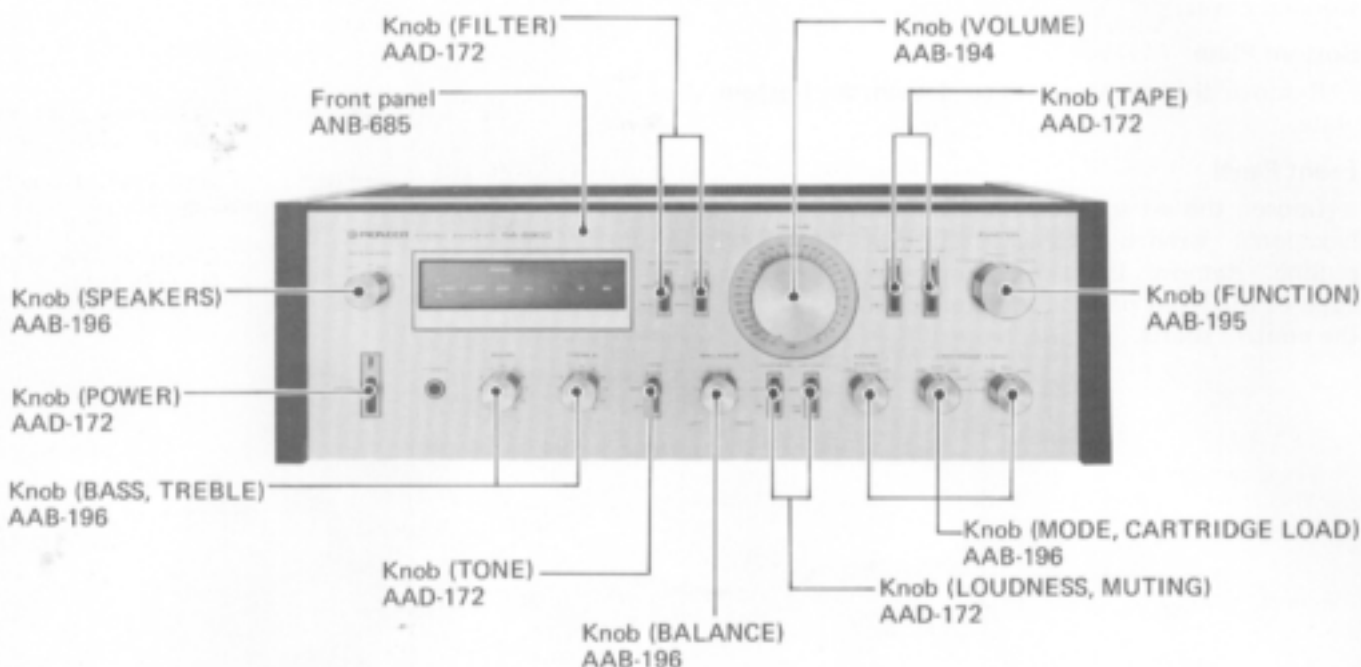

NOTE:

- The  mark found on some component parts indicates the importance of the safety factor of the part. Therefore, when replacing, be sure to use parts of identical designation.

Front View with Panel Removed

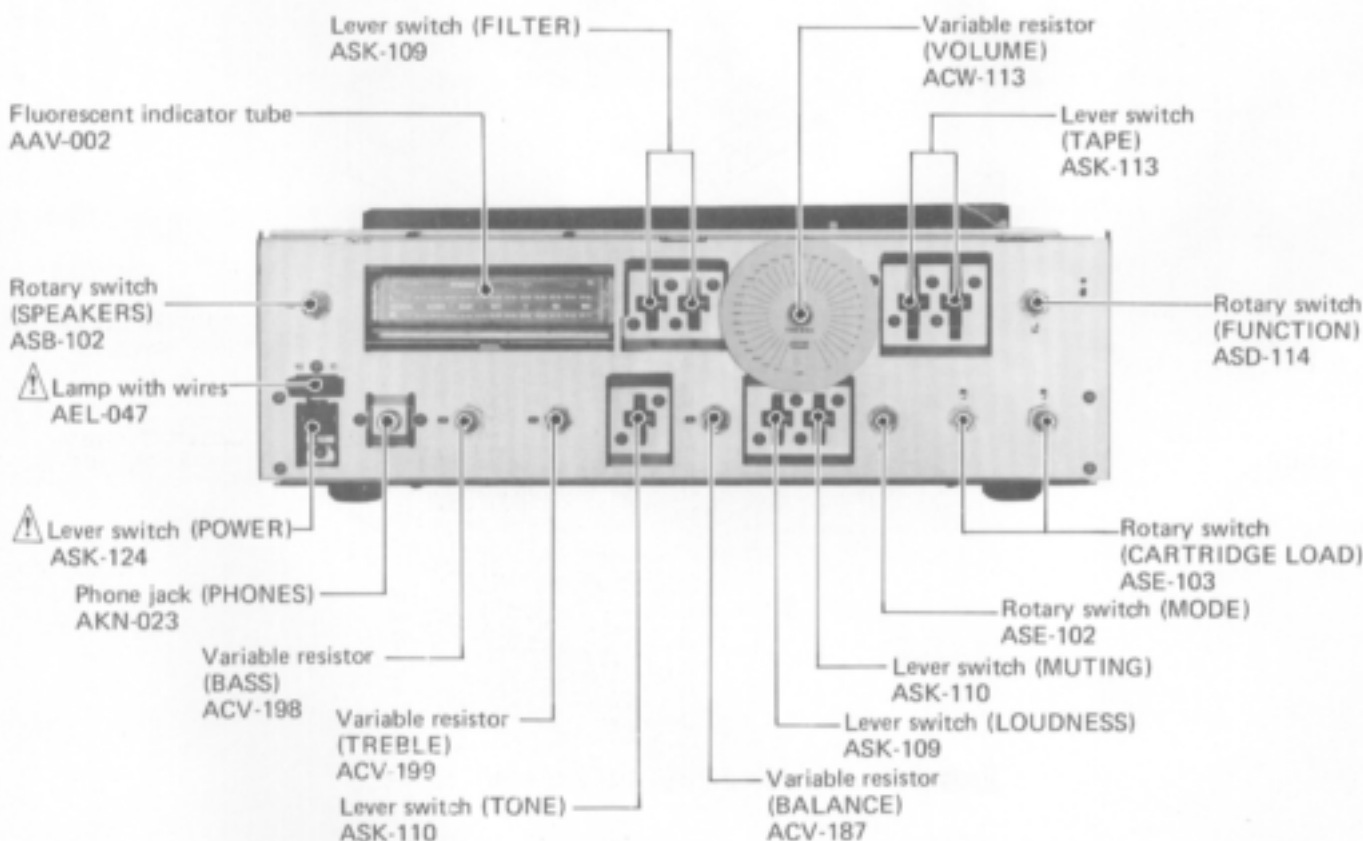

Top View

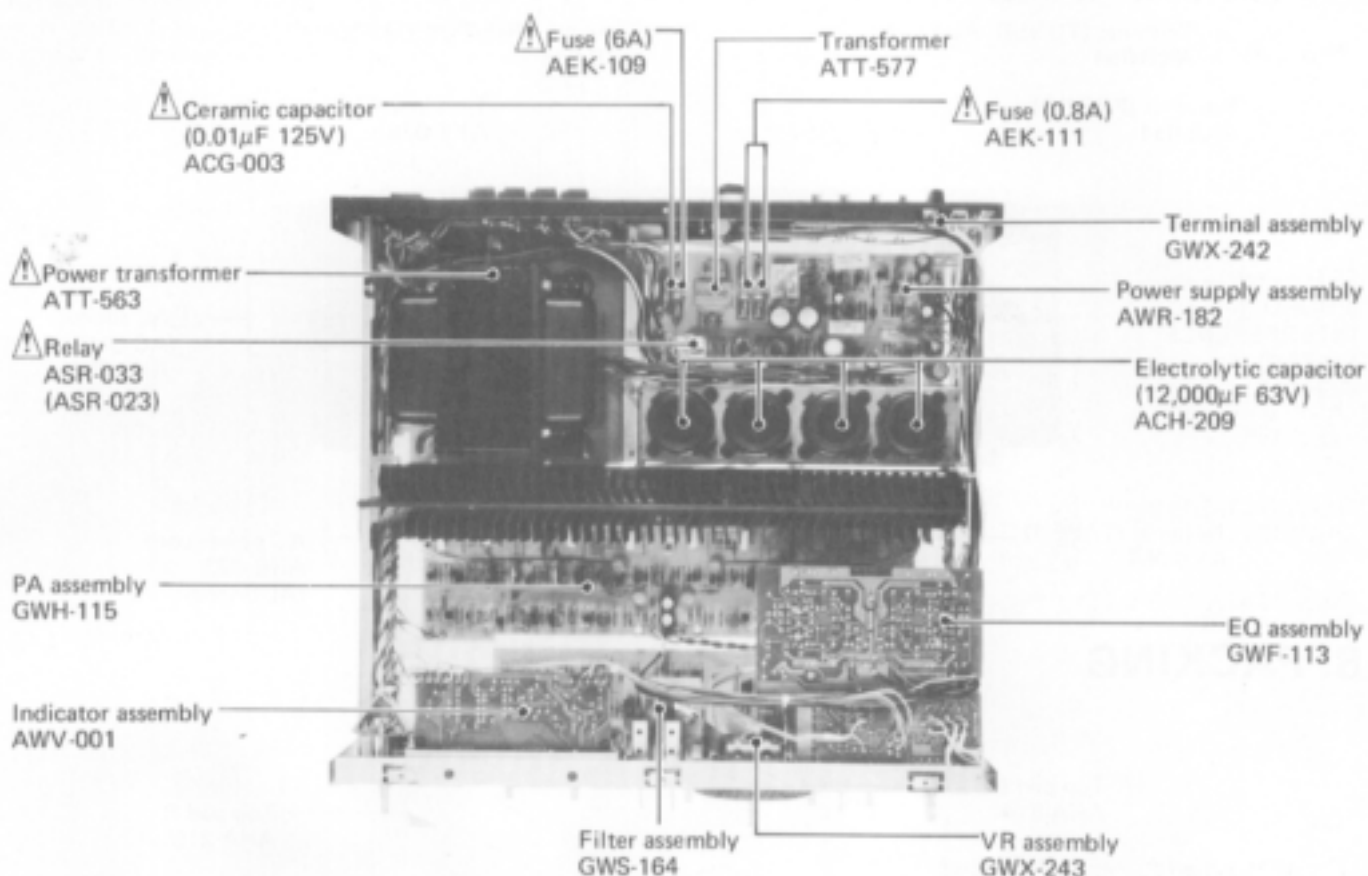

Bottom View

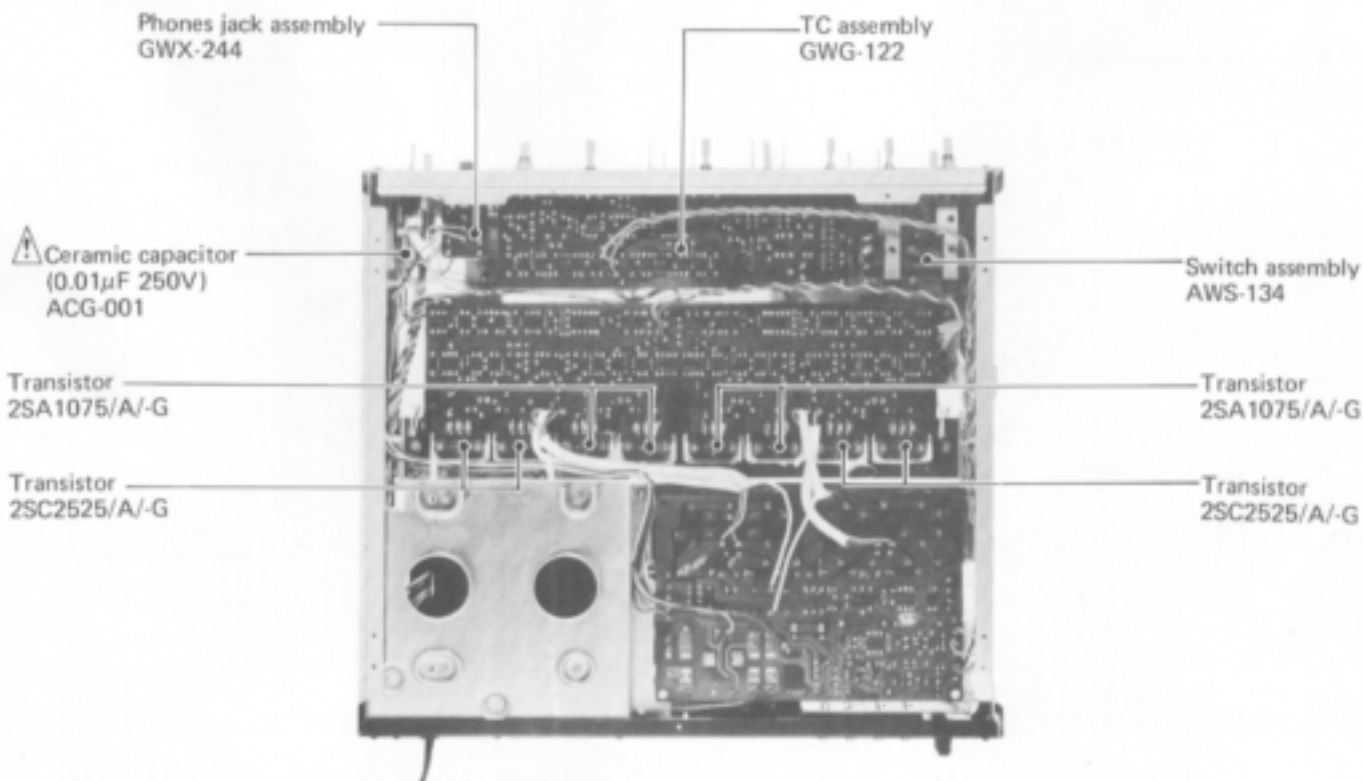

Rear Panel View

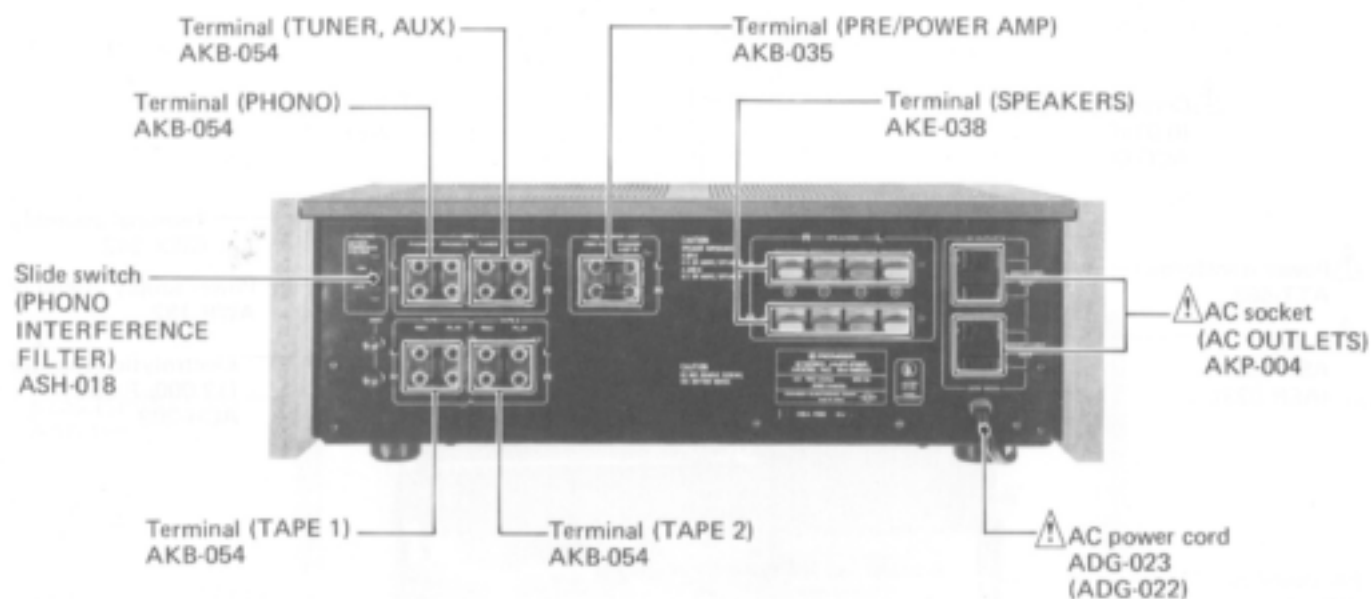

8. PACKING

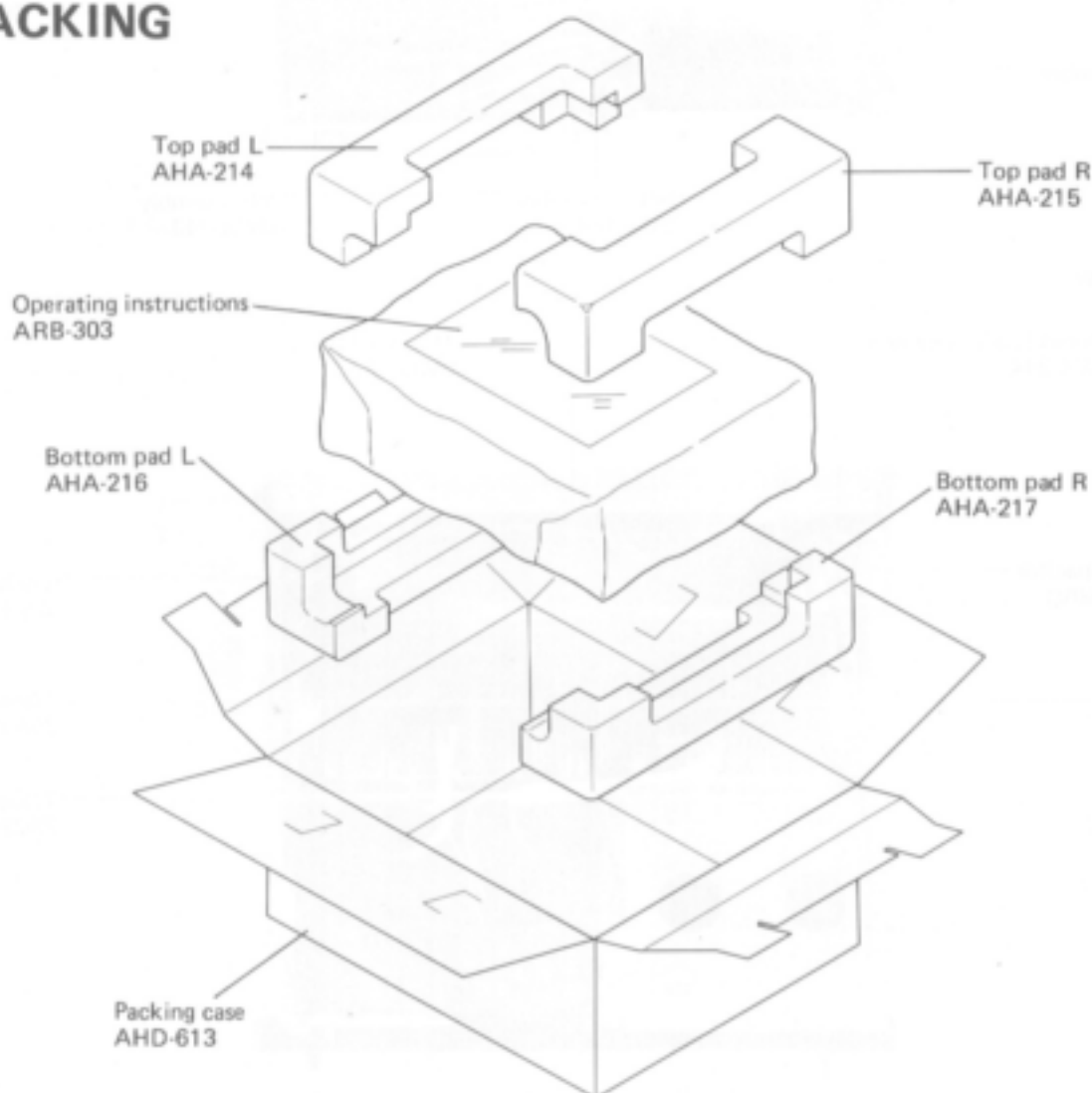

9. ADJUSTMENTS

Power Amplifier

Turn VR₇, VR₉ (L) and VR₈, VR₁₀ (R) fully around in the counter-clockwise direction, but set VR₅ (L) and VR₆ (R) to the center positions. Without any load or input signal, turn the POWER switch ON.

DC Balance

1. Adjust VR₅ (L) for 0V (to within $\pm 30\text{mV}$) between terminal No.15 and ground.
2. Adjust VR₆ (R) for 0V (to within $\pm 30\text{mV}$) between terminal No.20 and ground.

Idle Current

1. Adjust VR₇ (L) for 56mV between terminals TP₁ (+) and TP₃ (-). The potential difference between terminals TP₂ (+) and TP₄ (-) should register about 56mV at this time.
2. Adjust VR₈ (R) for 56mV between terminals TP₇ (+) and TP₅ (-). The potential difference between terminals TP₈ (+) and TP₆ (-) should register about 56mV at this time.
3. Adjust VR₉ (L) for 70mV between terminals TP₁ (+) and TP₃ (-). The potential difference between terminals TP₂ (+) and TP₄ (-) should register about 70mV at this time.
4. Adjust VR₁₀ (R) for 70mV between terminals TP₇ (+) and TP₅ (-). The potential difference between terminals TP₈ (+) and TP₆ (-) should register about 70mV at this time.

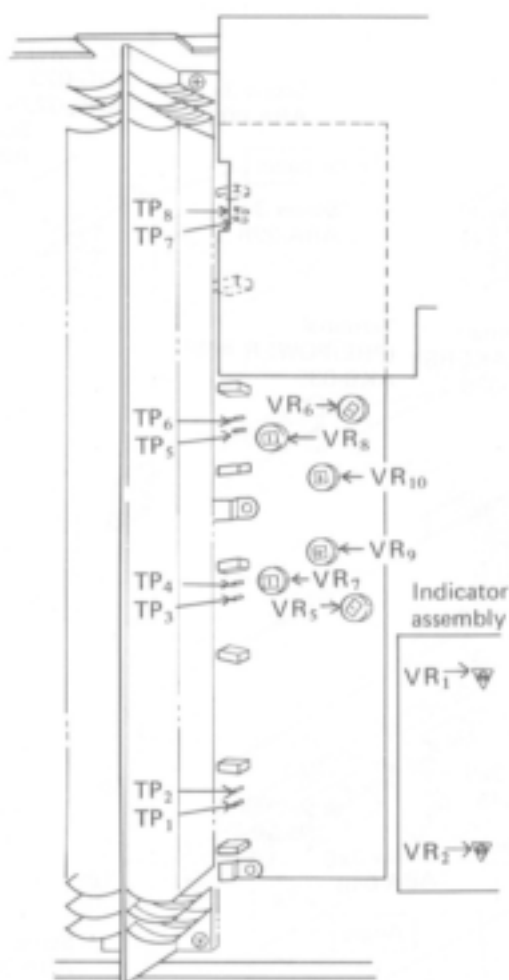

Output Power Indicator Calibration

1. Apply a 1kHz signal to the POWER AMP IN terminals (or any other input power amplifier input terminals).
2. Adjust the level of this input signal so that the voltage on the output terminals (SPEAKERS) read 8.9V (AC).
3. Adjust VR₁ (L) and VR₂ (R) so that the output power indicator read 10 watts.



10. EXPLODED VIEW

NOTES:

-  marked parts cannot be supplied.
- The  mark found on some component parts indicates the importance of the safety factor of the part. Therefore, when replacing, be sure to use parts of identical designation.

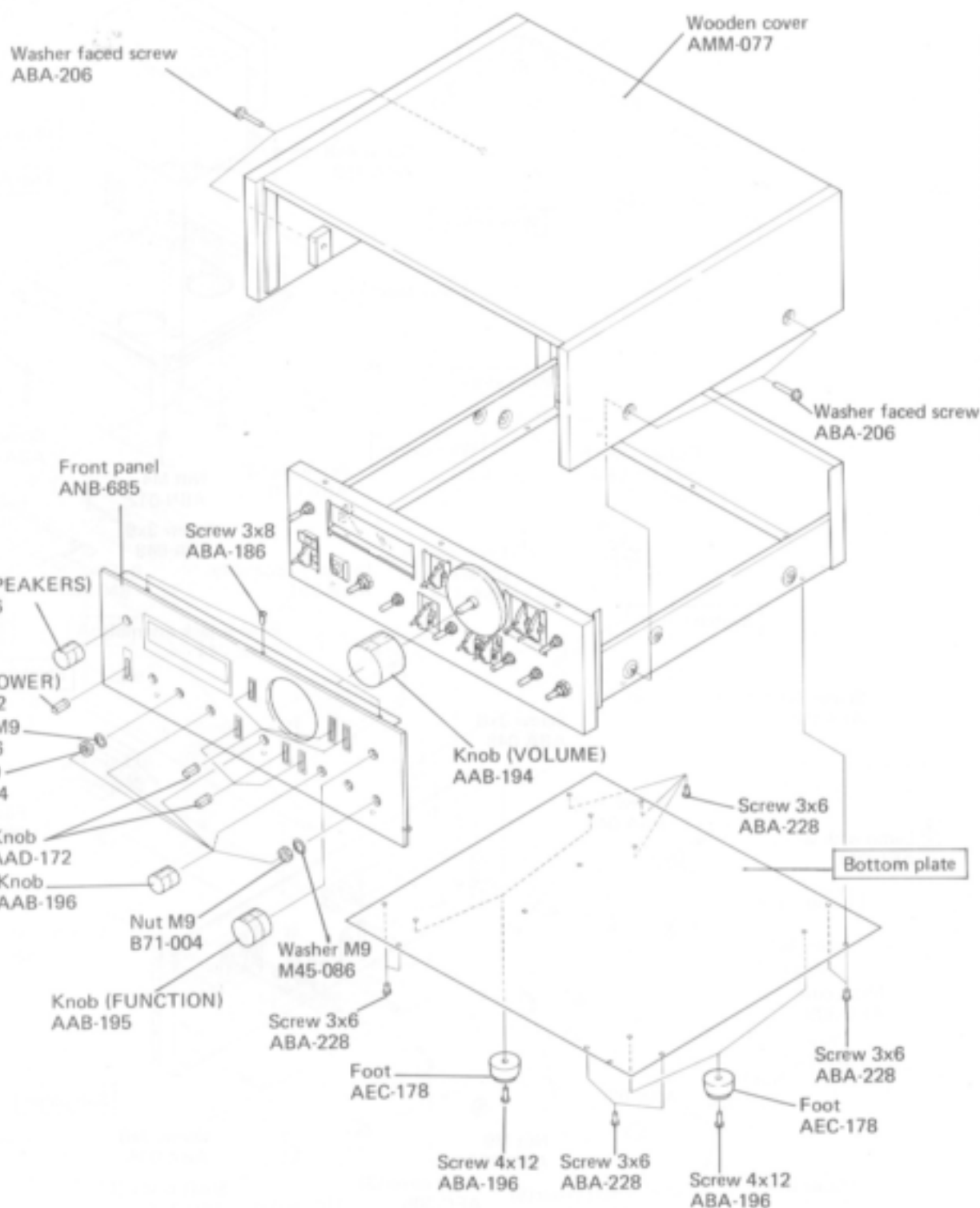

11. SCHEMATIC DIAGRAMS, P.C. BOARD PATTERNS AND PARTS LIST

NOTES:

- When ordering resistors, first convert resistance values into code form as shown in the following examples.

Ex. 1 When there are 2 effective digits (any digit apart from 0), such as 560 ohm and 47k ohm (tolerance is shown by J = 5%, and K = 10%).

560Ω	56 × 10 ¹	561	RD%PS	561J
47kΩ	47 × 10 ³	473	RD%PS	473J
0.5Ω	0R5		RN2H	05K
1Ω	010		RSIP	010K

Ex. 2 When there are 3 effective digits (such as in high precision metal film resistors).

5.62kΩ	562 × 10 ¹	5621	RN%SR	5621F
--------	-----------------------	------	-------	-------

- The  mark found on some component parts indicates the importance of the safety factor of the part. Therefore, when replacing, be sure to use parts of identical designation.



11.1 MISCELLANEA

Miscellaneous Parts

P. C. BOARD ASSEMBLIES

Part No.	Description
AWV-001	Indicator assembly
AWS-134	Switch assembly
AWR-182	Power supply assembly
GWH-115	PA assembly
GWG-122	TC assembly
GWS-164	Filter assembly
GWX-243	VR assembly
GWX-244	Phones jack assembly
GWF-113	EQ assembly
GWX-242	Terminal assembly

LAMP AND FUSES

Part No.	Symbol & Description
 AEL-047	PL1 Lamp with wires
 AEK-109	FU1 Fuse (6A)
 AEK-111	FU2, FU3 Fuse (0.8A)

SEMICONDUCTORS

Part No.	Symbol & Description
2SC2525/A/-G	Q1-Q4
2SA1075/A/-G	Q5-Q8





SWITCHES

Part No.	Symbol & Description
 ASB-102	S13 Rotary (SPEAKERS)
 ASK-124	S14 Lever (POWER)

CAPACITORS

Part No.	Symbol & Description
 ACG-001	C1 Ceramic 0.01/250V
CKDYF 473Z 50	C2, C4
CCDSL 221K 50	C5, C6

OTHERS

Part No.	Symbol & Description
 ATT-563	T1 Power transformer
 ADG-023	AC power cord
 (ADG-022)	
 AKP-004	AC socket (AC OUTLETS)
AKE-038	Terminal (SPEAKERS)
AKB-035	Terminal (PRE/POWER AMP)

List of Changed Parts for Factory Modification

List of changed parts information will be furnished whenever necessary and you are requested to amend parts number in this parts list.

Symbol	Part No.	Description

11.2 SCHEMATIC DIAGRAM

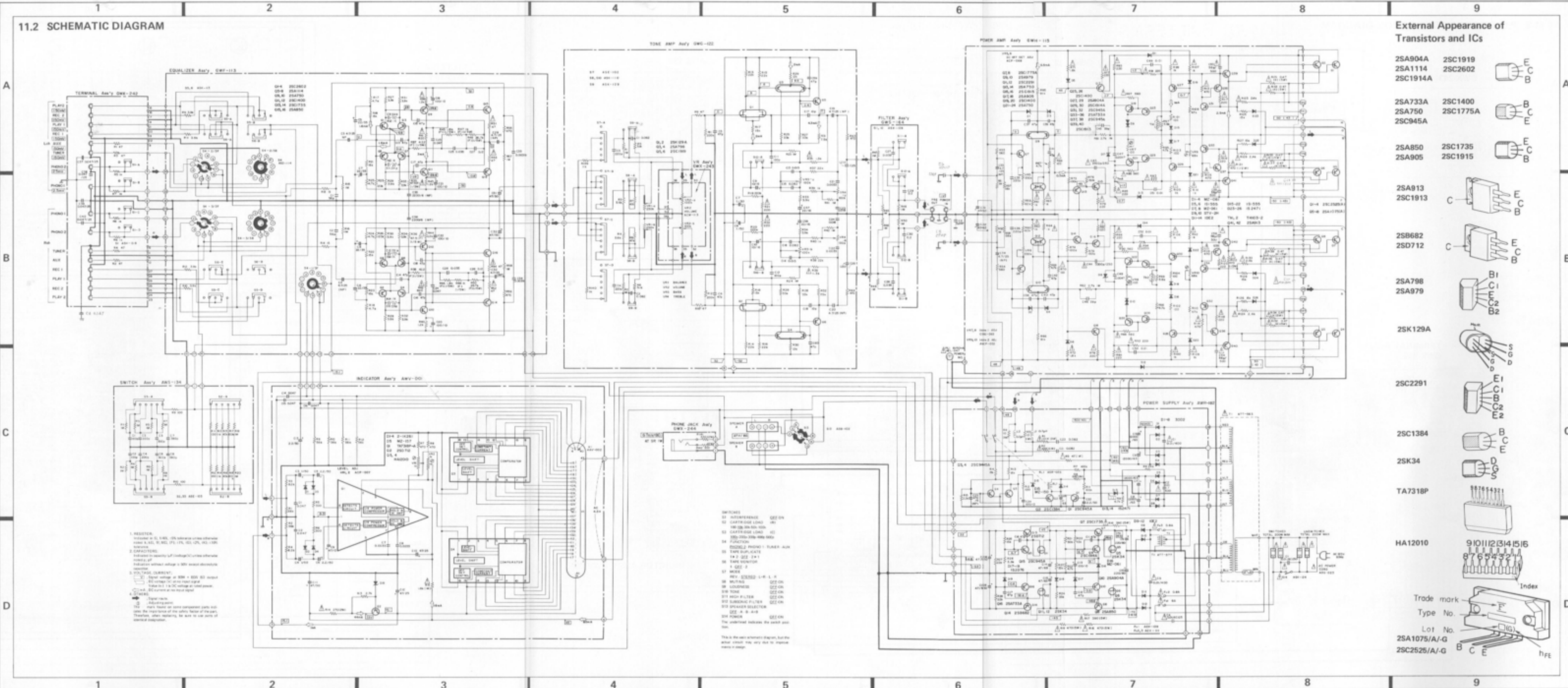

External Appearance of Transistors and ICs

- | | | |
|----------|----------|--|
| 2SA904A | 2SC1919 | |
| 2SA1114 | 2SC2602 | |
| 2SC1914A | | |
| 2SA733A | 2SC1400 | |
| 2SA750 | 2SC1775A | |
| 2SC945A | | |
| 2SA850 | 2SC1735 | |
| 2SA905 | 2SC1915 | |
| 2SA913 | 2SC1913 | |
| 2SB682 | 2SD712 | |
| 2SA798 | 2SA979 | |
| 2SK129A | | |
| 2SC2291 | | |
| 2SC1384 | | |
| 2SK34 | | |
| TA7318P | | |
| HA12010 | | |
- 91011234516
8765432
- Trade mark
Type No.
Lot No.
2SA1075/A-G
2SC2525/A-G

- SWITCHES
- 01 AUTOREVERSE ON
 - 02 CARTRIDGE LOAD ON
 - 03 CARTRIDGE LOAD ON
 - 04 CARTRIDGE LOAD ON
 - 05 FUNCTION
 - 06 EQUALIZER (PHONO) FLANGER ALN
 - 07 TAPE SUPPL. ACUTE ON
 - 08 TAPE MONITOR ON
 - 09 MUTE ON
 - 10 REV. STEREO ON
 - 11 MUTE ON
 - 12 LOGIC/REV. ON
 - 13 LOGIC/REV. ON
 - 14 TAPE ON
 - 15 HIGH FILTER ON
 - 16 SUBSONIC FILTER ON
 - 17 SPEAKER SELECTOR ON
 - 18 ON
 - 19 POWER ON
- The asterisk indicates the switch position.
- Note: Be sure to check the switch position before using the receiver.

1. RESISTOR
Indicates the value, tolerance, and temperature coefficient. For example, 10K indicates 10,000 ohms, 10K±5% indicates 10,000 ohms with a 5% tolerance, and 10K±5% (1/4W) indicates 10,000 ohms with a 5% tolerance and a 1/4 watt power rating.
2. CAPACITOR
Indicates the capacity, tolerance, and temperature coefficient. For example, 100μF indicates 100 microfarads with a tolerance of ±20% and a temperature coefficient of ±20%.
3. POLARITY
Indicates the polarity of the capacitor. For example, + indicates the positive terminal, and - indicates the negative terminal.
4. THERMISTOR
Indicates the temperature coefficient of the resistor. For example, 100Ω/°C indicates a resistor with a value of 100 ohms at a temperature of 0°C.
5. DIODE
Indicates the direction of current flow. For example, a diode symbol with an arrow pointing to the right indicates current flow from left to right.
6. TRANSISTOR
Indicates the type of transistor. For example, NPN indicates a normal p-n-p transistor, and PNP indicates a normal p-n-p transistor.
7. IC
Indicates the type of integrated circuit. For example, 741 indicates a 741 operational amplifier.
8. TUBE
Indicates the type of vacuum tube. For example, 6X4 indicates a 6X4 diode.
9. COIL
Indicates the inductance value. For example, 100μH indicates a 100 microhenry coil.
10. ANTENNA
Indicates the antenna connection point.
11. GROUND
Indicates the ground connection point.
12. POWER
Indicates the power supply connection point.
13. SPEAKER
Indicates the speaker connection point.
14. TAPE
Indicates the tape deck connection point.
15. EQUALIZER
Indicates the equalizer connection point.
16. MUTE
Indicates the mute connection point.
17. LOGIC/REV.
Indicates the logic/reverse connection point.
18. TAPE SUPPL. ACUTE
Indicates the tape supply acute connection point.
19. TAPE MONITOR
Indicates the tape monitor connection point.
20. CARTRIDGE LOAD
Indicates the cartridge load connection point.
21. AUTOREVERSE
Indicates the autoreverse connection point.
22. FUNCTION
Indicates the function connection point.
23. EQUALIZER (PHONO) FLANGER ALN
Indicates the equalizer (phono) flanger alignment connection point.
24. TAPE SUPPL. ACUTE
Indicates the tape supply acute connection point.
25. TAPE MONITOR
Indicates the tape monitor connection point.
26. MUTE
Indicates the mute connection point.
27. REV. STEREO
Indicates the reverse stereo connection point.
28. MUTE
Indicates the mute connection point.
29. LOGIC/REV.
Indicates the logic/reverse connection point.
30. LOGIC/REV.
Indicates the logic/reverse connection point.
31. TAPE
Indicates the tape connection point.
32. HIGH FILTER
Indicates the high filter connection point.
33. SUBSONIC FILTER
Indicates the subsonic filter connection point.
34. SPEAKER SELECTOR
Indicates the speaker selector connection point.
35.
Indicates an unconnected terminal.
36. POWER
Indicates the power connection point.

11.3 P.C. BOARDS CONNECTION DIAGRAM

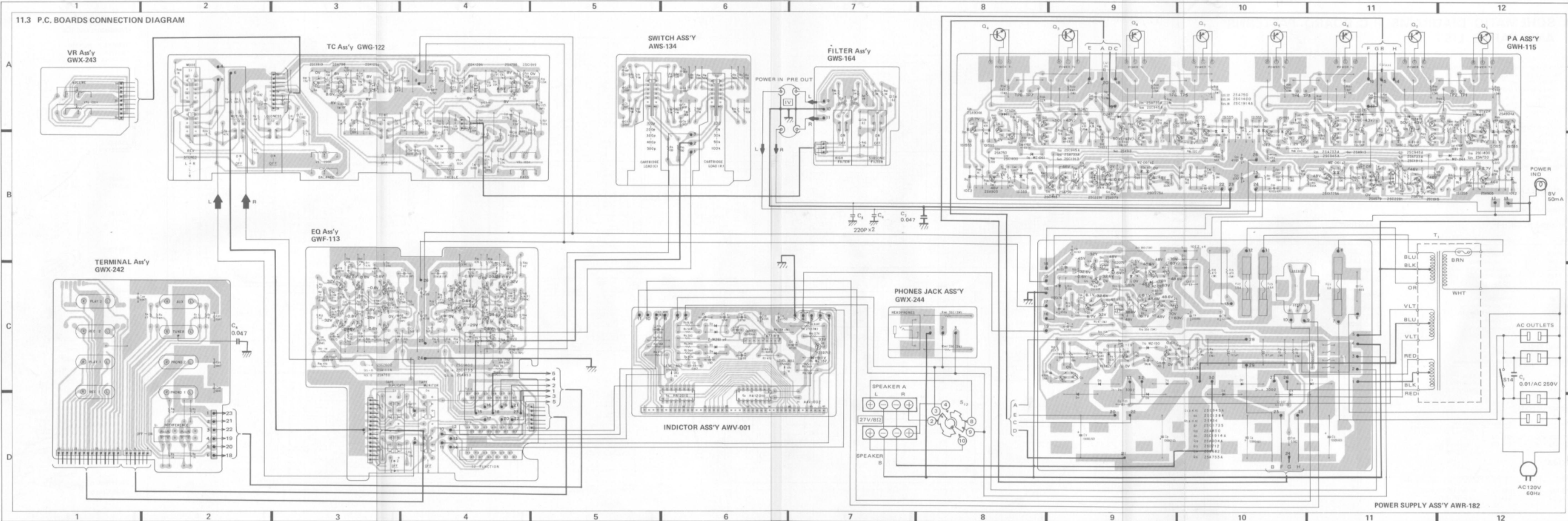

POWER SUPPLY ASS'Y AWR-182

11.4 TERMINAL ASSEMBLY (GWX-242)

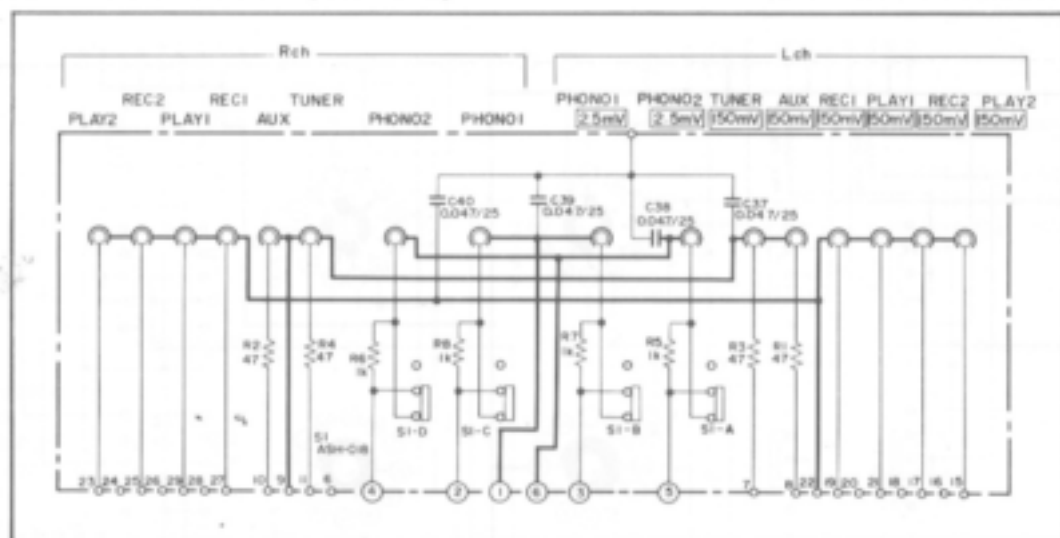

Parts List

CAPACITORS

Part No.	Symbol & Description
CKDBC 473Z 25	C37-C40

Note: When ordering resistors, convert the resistance value into code form, and then rewrite the part no. as before.

RESISTORS

Part No.	Symbol & Description
RD&PM 000 J	R1-R8

OTHERS

Part No.	Symbol & Description
ASH-018	S1 Slide switch (PHONO INTERFERENCE)
AKB-054	Terminal (INPUT, TAPE)

11.5 SWITCH ASSEMBLY (AWS-134)

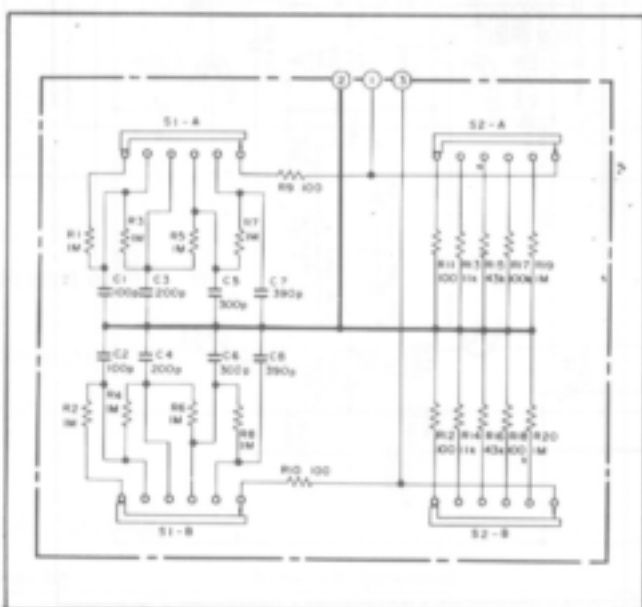

Parts List

SWITCHES

Part No.	Symbol & Description
ASE-103	S1, S2 Rotary (CARTRIDGE LOAD)

CAPACITORS

Part No.	Symbol & Description
CQSH 101K 50	C1, C2
CQSH 201K 50	C3, C4
CQSH 301K 50	C5, C6
CQSH 391K 50	C7, C8

Note: When ordering resistors, convert the resistance value into code form, and then rewrite the part no. as before.

RESISTORS

Part No.	Symbol & Description
RD&PM 000 J	R1-R20

11.6 EQ ASSEMBLY (GWF-113)

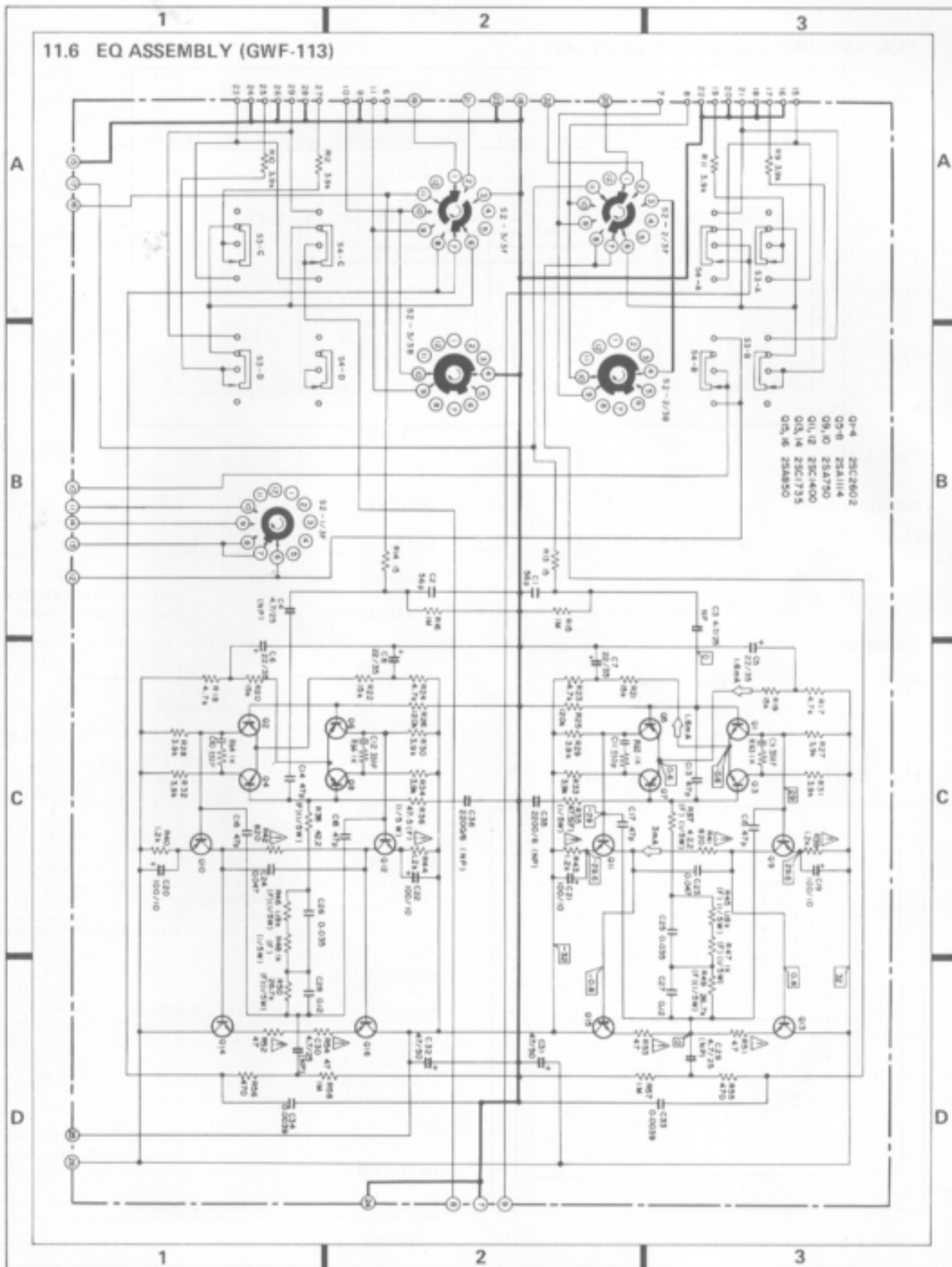

Parts List of EQ Assembly (GWF-113)

SWITCHES

Part No.	Symbol & Description
ASD-114	S2 Rotary (FUNCTION)
ASK-113	S3 Lever (DUPLICATE)
ASK-113	S4 Lever (MONITOR)

CAPACITORS

Part No.	Symbol & Description
CQSH 560K 50	C1, C2
ACH-318	C3, C4, C29, C30 Electrolytic 4.7/25 (NP)
CEA 220P 35	C5-C8
CCDSL 470K 50	C13-C18
CEA 101P 10	C19-C22
CKDYB 331K 50	C9-C12
QOMA 473K 50	C23, C24
QOPA 353G 50	C25, C26
QOPA 124G 50	C27, C28
CEA 470P 50	C31, C32
QOMA 392J 50	C33, C34
ACH-339	C35, C36 Electrolytic 2200/6V (NP)

RESISTORS

Part No.	Symbol & Description
RD¼PM 000 J	R9-R34, R55-R58, R63-R66
RN½SQ 0000 F	R35-R38, R45-R50
RD¼PSF 000 J	R39-R44, R51-R54

SEMICONDUCTORS

Part No.	Symbol & Description
2SC2602	Q1-Q4
2SA1114	Q5-Q8
2SA750	Q9, Q10
2SC1400	Q11, Q12
2SC1735	Q13, Q14
2SA850	Q15, Q16

11.7 FILTER ASSEMBLY (GWS-164)

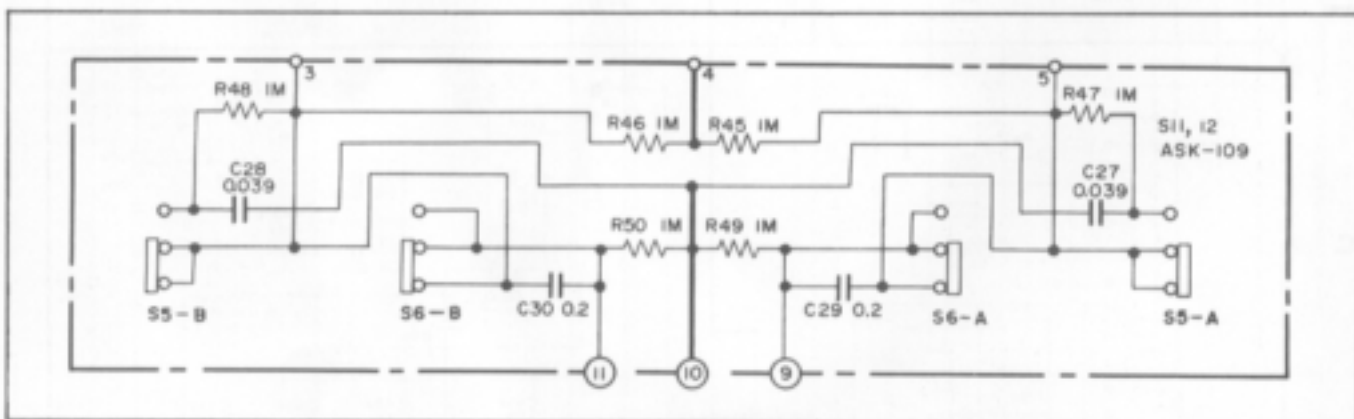

Parts List

SWITCHES

Part No.	Symbol & Description
ASK-109	S5, S6 Lever (FILTER)

CAPACITORS

Part No.	Symbol & Description
QOMA 393K 50	C27, C28
QOMA 204J 50	C29, C30

RESISTORS

Part No.	Symbol & Description
RD¼PM 000 J	R45-R50

Note: When ordering resistors, convert the resistance value into code form, and then rewrite the part no. as before.

11.8 TC ASSEMBLY (GWG-122)

Q1,2 2SK129A
 Q3,4 2SA79B
 Q5,6 2SC1919

VR1 BALANCE
 VR2 VOLUME
 VR3 BASS
 VR4 TREBLE

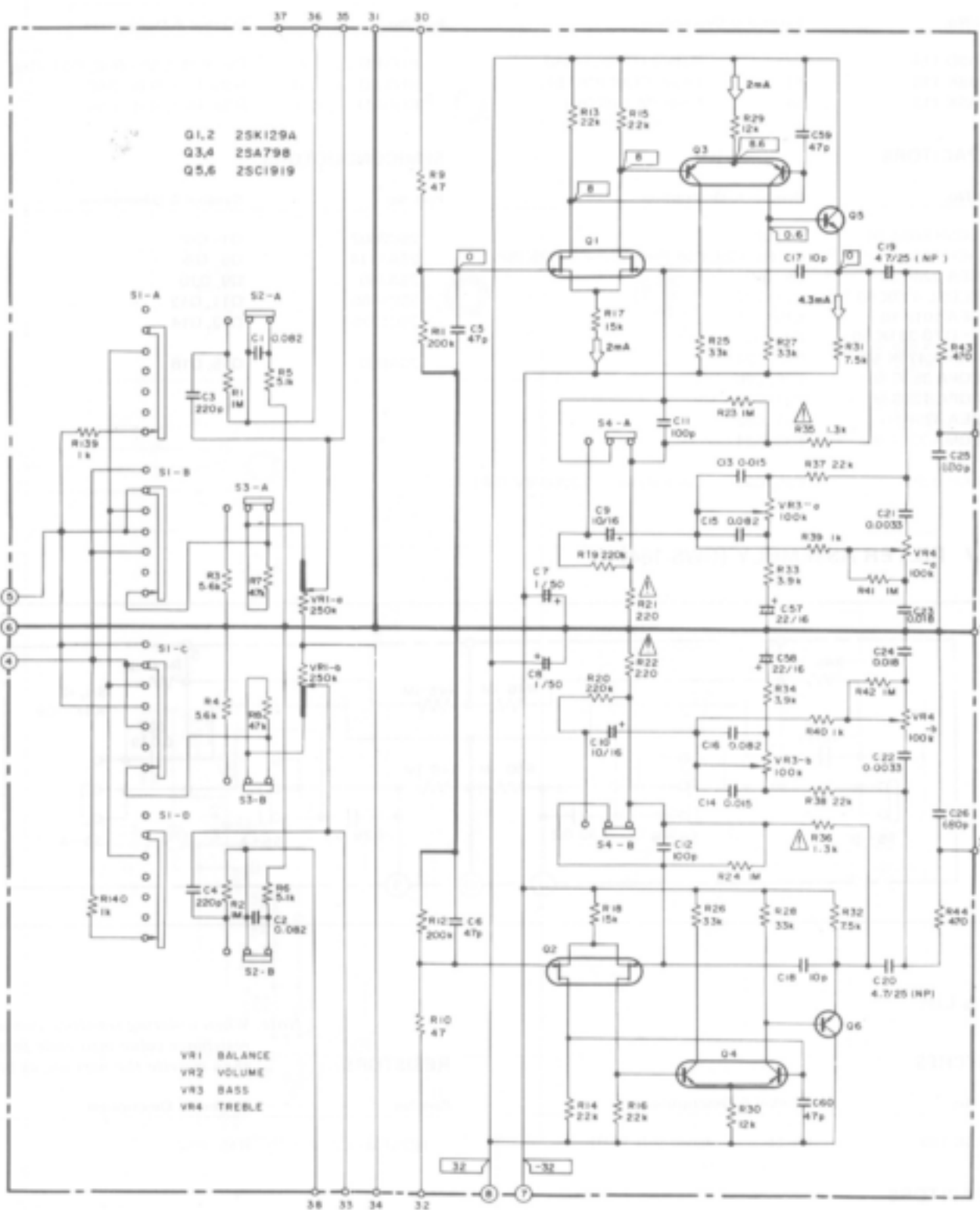

Parts List of TC Assembly (GWG-122)

SWITCHES

Part No.	Symbol & Description
ASE-102	S1 Rotary (MODE)
ASK-109	S2 Lever (LOUDNESS)
ASK-110	S3 Lever (MUTING)
ASK-110	S4 Lever (TONE)

CAPACITORS

Part No.	Symbol & Description
COMA 823J 50	C1, C2, C15, C16
CCDSL 221K 50	C3, C4,
CCDSL 470K 50	C5, C6, C59, C60
CEA 010P 50	C7, C8
CEANL 100M 16	C9, C10
CCDSL 101K 50	C11, C12
COMA 153J 50	C13, C14
CCDSL 100F 50	C17, C18
ACH-318	C19, C20 Electrolytic 4.7/25(NP)
COMA 332J 50	C21, C22
CCDSL 681K 50	C25, C26
COMA 183J 50	C23, C24
CEANL 220M 16	C57, C58

Note: When ordering resistors, convert the resistance value into code form, and then rewrite the part no. as before.

RESISTORS

Part No.	Symbol & Description
ACV-187	VR1 Variable (BALANCE)
ACV-198	VR3 Variable (BASS)
ACV-199	VR4 Variable (TREBLE)
RD4PM 000 J	R1-R20, R23-R34, R37-R44, R139, R140
RD4PSF 000 J	R21, R22, R35, R36

SEMICONDUCTORS

Part No.	Symbol & Description
2SK129A	Q1, Q2
2SA798	Q3, Q4
2SC1919	Q5, Q6
(2SC1400)	

List of Changed Parts for Factory Modification

List of changed parts information will be furnished whenever necessary and you are requested to amend parts number in this parts list.

Symbol	Part No.	Description

11.9 VR ASSEMBLY (GWX-243)

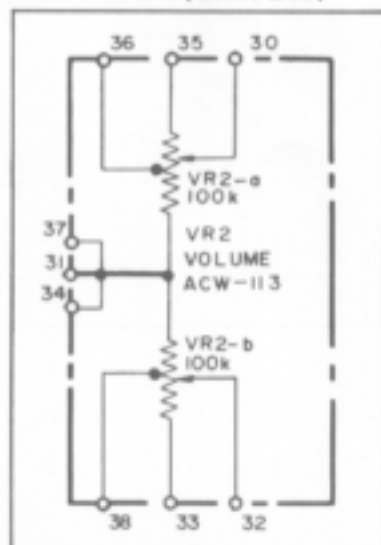

Parts List

Part No.	Symbol & Description
ACW-113	Variable resistor (VOLUME)

11.10 PA ASSEMBLY (GWH-115)

Parts List

CAPACITORS

Part No.	Symbol & Description
CEA 470P 63	C31, C32
ACH-318	C33, C34 Electrolytic 4.7/25V (NP)
CCDSL 221K 50	C35, C36
CCDSL 470K 50	C37-C40
CCDSL 470K 50	C41, C42
△CQMA 332K 250	C43, C44
CCDSL 390K 50	C45, C46
CQMA 472K 50	C47, C48
CQMA 103K 50	C49-C52
△CCDSL 560K 500	C53-C56
△CKDYF 103Z 500	C61, C62

Note: When ordering resistors, convert the resistance value into code form, and then rewrite the part no. as before.

RESISTORS

Part No.	Symbol & Description
ACP-068	VR5, VR6 Semifixed 330k-B
C92-063	VR7, VR8 Semifixed 100-B
ACP-002	VR9, VR10 Semifixed 68k-B
RD%PM □□□ J	R51-R54, R57-R60, R65-R68, R73-R76
RD%PM □□□ J	R95-R98, R101-R104, R109, R110
RD%PM □□□ J	R125-R128
△RD%PSF □□□ J	R61-R64, R69-R72, R77-R80, R83-R90
△RD%PSF □□□ J	R91-R94, R99, R100, R105-R108
△RD%PSF □□□ J	R111-R120, R123, R124, R129, R130
RS1P □□□ J	R81, R82
△RD%PSF □□□ J	R121, R122
△ACN-041	R131-R138 Wire wound 0.47/5W

SEMICONDUCTORS

Part No.	Symbol & Description
2SC1775A-E* or -F*	Q7, Q8
2SA979-F* or -G*	Q9, Q10
*hfe of Q7 and Q8 should have the E-rank, if Q9 and Q10 have the F-rank.	
*hfe of Q7 and Q8 should have the F-rank, if Q9 and Q10 have the G-rank.	
2SC2291	Q11, Q12
2SA750 (2SA726S)	Q13, Q14
2SC1915	Q15, Q16
2SA905	Q17, Q18
2SC1400	Q19, Q20, Q25, Q26
2SA750	Q21-Q24
2SA904A	Q27, Q28
2SC1914A	Q29, Q30
2SC945A	Q31, Q32, Q37, Q38
2SA733A	Q33-Q36

Part No.	Symbol & Description
2SC1913-R** or -Q**	Q39, Q40
2SA913-R** or -Q**	Q41, Q42
**hfe of Q39-Q42 should have the same value.	
1S1555 (1S2473)	D5, D6, D15-D22
10E2	D11-D14
1S2471	D23-D26
MZ-061 (WZ-061)	D1-D4, D7, D8
STV2H	D9, D10
TH103-2	Th1, Th2

List of Changed Parts for Factory Modification

List of changed parts information will be furnished whenever necessary and you are requested to amend parts number in this parts list.

Symbol	Part No.	Description

11.11 INDICATOR ASSEMBLY (AWV-001)

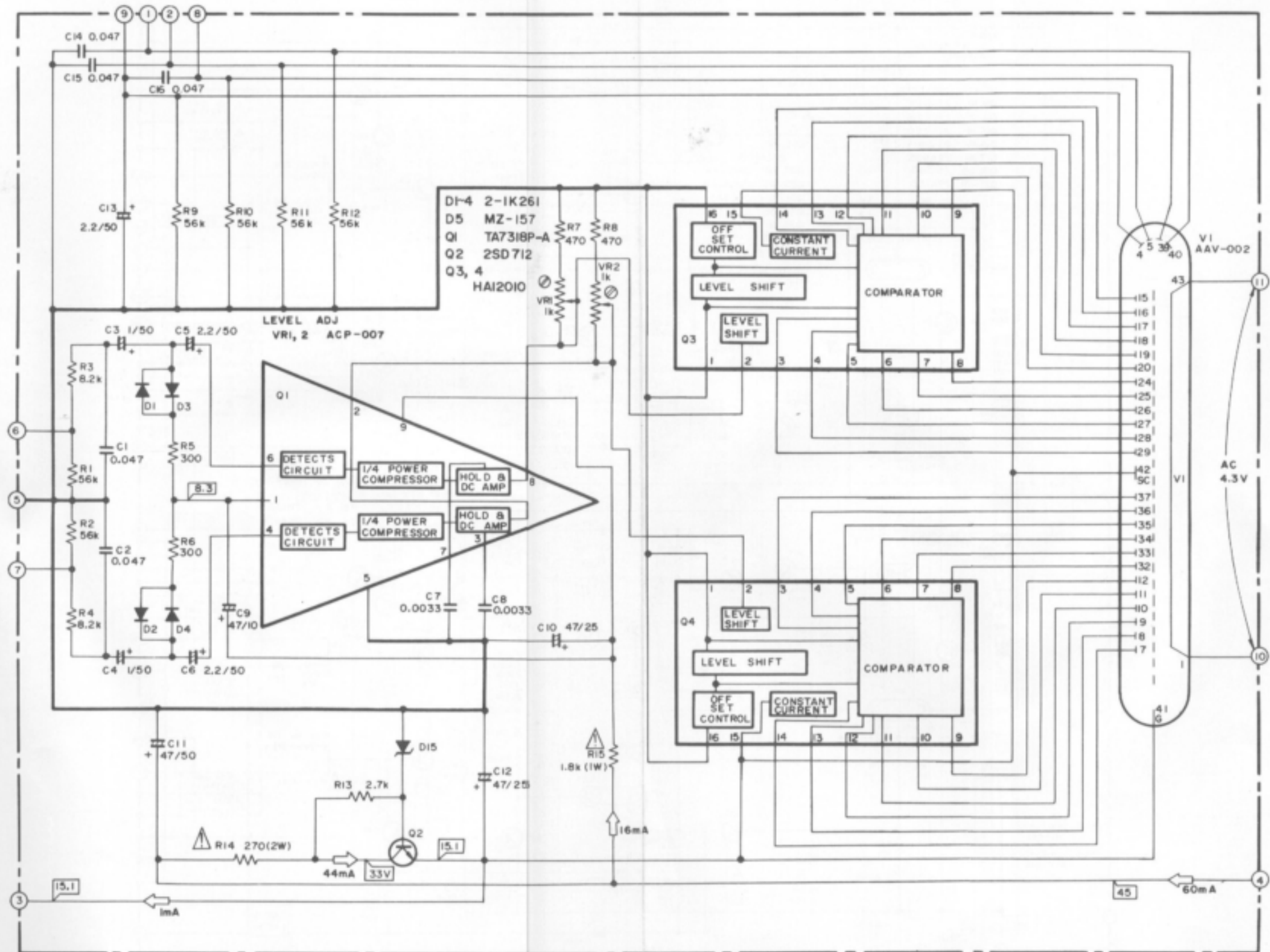

Parts List of Indicator Assembly (AWV-001)

CAPACITORS

Part No.	Symbol & Description
QOMA 473K 50	C1, C2
CEA 010P 50	C3, C4
CEA 2R2P 50	C5, C6, C13
QOMA 332K 50	C7, C8
CEA 470P 10	C9
CEA 470P 25	C10, C12
CEA 470P 50	C11
CKDYF 473Z 50	C14-C16

Note: When ordering resistors, convert the resistance value into code form, and then rewrite the part no. as before.

RESISTORS

Part No.	Symbol & Description
ACP-007	VR1, VR2 Semifixed 1k-B
△ RS2P 000 J	R14
△ RS1P 000 J	R15
RD%PM 000 J	R1-R3

SEMICONDUCTORS

Part No.	Symbol & Description
TA7318P-A	Q1
2SD712	Q2
HA12010	Q3, Q4
2-1K261	D1-D4
MZ-157 (WZ-157)	D5

OTHERS

Part No.	Symbol & Description
AAV-002	V1 Fluorescent indicator tube
ABA-048	Screw 3x6

11.12 PHONES JACK ASSEMBLY (GWX-244)

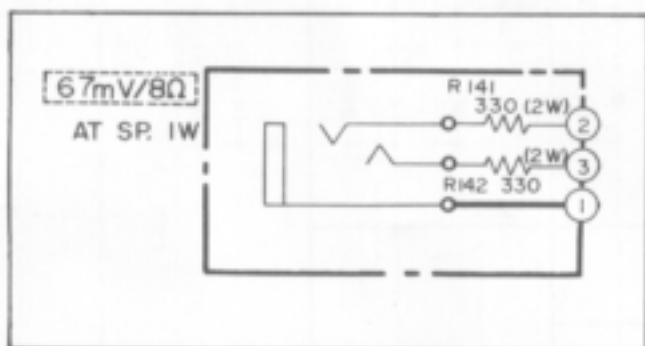

Parts List

Part No.	Symbol & Description
RS2P 331J AKN-023	R141, R142 Phone jack (PHONES)

11.13 POWER SUPPLY ASSEMBLY (AWR-182)

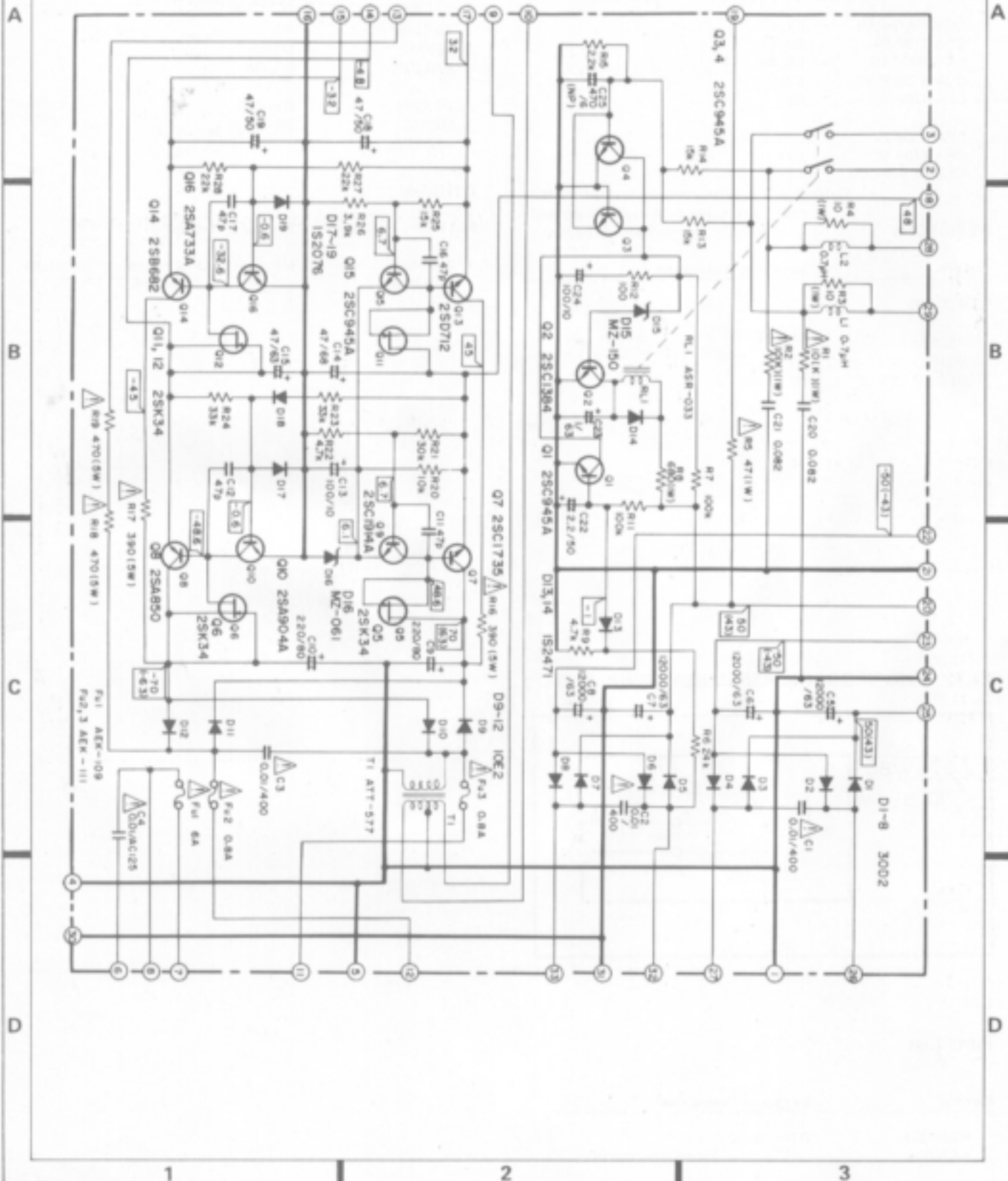

Parts List of Power Supply Assembly (AWR-182)

CAPACITORS

Part No.	Symbol & Description
CGMA 103K 400	C1-C3
△ACG-003	C4 Ceramic 0.01/125V
ACH-209	C5-C8 Electrolytic 12000/63V
CEA 221P 80	C9, C10
CCDSL 470K 50	C11, C12, C16, C17
CEA 101P 10	C13
CEA 470P 63	C14, C15
CEA 470P 50	C18, C19
CGMA 823K 50	C20, C21
CEANL 2R2M 50	C22
CEA 010P 63	C23
CEA 101P 16	C24
ACH-340	C25

Note: When ordering resistors, convert the resistance value into code form, and then rewrite the part no. as before.

RESISTORS

Part No.	Symbol & Description
△RN1H 000 K	R1, R2
RS1P 000 J	R3, R4, R8
△RS1P 000 J	R5
△RT5B 000 K	R16-R19
RD4PM 000 J	R6, R7, R9, R11-R15, R20-R28

SEMICONDUCTORS

Part No.	Symbol & Description
2SC945A	Q1, Q3, Q4, Q15
2SC1384	Q2
2SK34	Q5, Q6, Q11, Q12
2SC1735	Q7
2SA850	Q8
2SC1914A	Q9
2SA904A	Q10
2SD712	Q13
2SB682	Q14
2SA733A	Q16
30D2	D1-D8
(GP-25D)	
10E2	D9-D12
(SIB01-02)	
1S2471	D13, D14
WZ-150	D15
WZ-061	D16
1S2076	D17-D19
(1S1555)	

OTHERS

Part No.	Symbol & Description
ATT-577	T1 Transformer (for FL)
△ASR-033	RL1 Relay
△(ASR-023)	
△AEC-279	Capacitor cover
ABA-048	Screw 3x6
ABA-051	Screw 3x12
ABE-020	Washer

List of Changed Parts for Factory Modification

Symbol	Part No.	Description