

marantz *Stereo* console

Model 7

INSTRUCTION MANUAL

You will find the model 7 straightforward and remarkably easy to use. The basic controls are the four large knobs grouped to the left. These are the SELECTOR, VOLUME control, stereo/monophonic MODE selector, and BALANCE control. The latter is merely a means for adjusting stereo programs so that they appear to be naturally and evenly spread out between the two loudspeakers. With the exception of the Power Switch, all the other controls may be left in their normal center positions until you have become familiar with their purposes.

PRELIMINARY NOTES

UNPACKING

After unpacking, replace all fillers and the plastic protective wrap in the carton for storage. Should it ever become necessary to ship the model 7 to another location, it must be packed in exactly the same manner in order to prevent internal or surface damage. The packing has been designed to support the unit firmly but *without pressure on the tubes, knobs, or other projections*. The plastic wrap protects the finish from abrasion.

WARRANTY

A warranty card, bearing the serial number of the unit you purchased and listing warranty terms, is enclosed with every unit that leaves our plant. For your protection it is most important that you properly fill in this card and return it promptly after purchase. Should you not find this card enclosed it is the responsibility of the dealer from whom you purchased the unit to supply this card to you.

INSTALLATION

MECHANICAL

1. Shock-mount Release Remove the large chrome-plated screw located nearest the central area of the bottom plate. This is an 8-32 x $\frac{1}{2}$ " screw which must be firmly replaced whenever the unit is to be shipped.

2. Mounting A cutout 14 $\frac{3}{16}$ " wide by 5 $\frac{3}{16}$ " high will just clear the chassis and projecting screw-heads. The front panel is larger than this dimension and will hide the edges of the cutout. Four small starting holes should be drilled for the #4 oval-head mounting screws. Their positions should be carefully located by temporarily inserting the preamplifier. Do not use the panel as a drill guide — a slip may result in damage.

When planning the installation try to arrange the associated components so that their power transformers are not too close to the preamplifier, especially the side toward the Selector. This will minimize the possibility of inductive hum pickup.

ELECTRICAL

1. Powering Plug the power cord into a source supply 105 to 125 volts, 50 to 60 cycles AC only.

2. AC Convenience Outlets On the rear panel are 6 AC outlets to be used for powering associated components, such as amplifiers and tuners. Five of these are controlled by the front-panel Power Switch. The sixth, marked "Unswitched Outlet", remains live and may be used for any turntable which must be controlled by its own switch.

SIGNAL CONNECTIONS

All signal connections to the Stereo Console should be made with standard shielded audio cables. On the rear panel are two horizontal rows of input and output jacks. The upper row is marked "Channel A", and feeds the left side of the system. The lower row is marked "Channel B", and refers to the right side of the system. Channel A is generally used for monophonic sources.

1. Amplifiers Connect a shielded cable between the "left" amplifier and one of the Channel A output jacks marked "To Amplifiers". Similarly, connect the "right" amplifier with the corresponding Channel B output. There are two jacks connected to the output of each channel and either may be used (the spares may be used for bridging other high impedance devices across the outputs).

NOTE: If the amplifiers have input gain controls, these should normally be turned up fully clockwise. Amplifier gain controls often have an adverse effect on transient response and stability.

2. Tuners

- a) FM-AM: Plug the FM tuner into Channel A, and AM tuner into Channel B. To use either one monophonically turn the MODE knob to the corresponding channel. For FM-AM stereo reception turn the MODE to "STEREO".
- b) FM (multiplex): Connect the channel A or left output of a multiplex tuner or adapter into the upper "FM (Multiplex)" input and the channel B or right output to the lower input.
- c) TV: Monophonic TV sound may be connected to Channel A. Stereo broadcasts in combination with AM or FM may be treated as described in the "FM-AM" paragraph above by inserting the second source into Channel B.

3. Tape

- a) TAPE-HEADS: Connect to "Tapehead" inputs. Follow the manufacturer's recommendation for optimum cable capacitance and resistive termination. It may be necessary to ground the tape deck to the preamplifier "Chassis Ground" to reduce excessive hum.
- b) TAPE RECORDER: Connect the recorder's playback outputs to the preamplifier "Tape" inputs. Also, connect the preamplifier "Recording Outputs" to the inputs of the tape recorder. The program source to which the SELECTOR is turned will be fed from the Recording Outputs. To listen to tape playback or (where the machine has this facility) to monitor a recording, depress the "TAPE" lever.
- c) A second machine can be connected to the "Auxiliary" inputs if it is not to be used for recording.

4. Phono Two sets of Phono inputs are provided. Both may be used for stereo connection or, if desired, one set for a stereo cartridge and the other for one or two monophonic cartridges (one in each channel). Phono equalization is automatically applied by the SELECTOR.

The procedure outlined below will minimize the possibility of hum pickup:

- a) Connect a separate grounding wire between the turn-table chassis and the "Chassis Ground" on the rear panel of the preamplifier.
- b) If the arm is mounted on a wood panel or is otherwise insulated from the turn-table, it too should be connected to the grounding wire with a short jumper wire to the arm base or one of its mounting screws. If the two pairs of signal wires in the arm have a single overall shield, this may be grounded instead of the arm itself.
- c) Keep the two input connecting cables and the grounding wire closely together. In three-wire (common ground) systems this will minimize ground loops. Where a second arm is mounted on the same turn-table, group its cables with the others. A neat method is to twist them loosely together and bind with a turn of electrical tape at each end.

5. Microphone Frequency response will be flat at this position of the SELECTOR. These inputs have an impedance of one megohm.

LOUDSPEAKER CONNECTION AND PLACEMENT

Ordinary 18 gauge lamp cord may be used for connection between an amplifier and loudspeaker if the distance is short. If more than 25 or 30 feet is required, it would be advisable to use a heavier gauge to reduce power loss and damping factor deterioration.

"Phasing" of loudspeakers will be made easier if each lead wire can be coded for identification. One wire in each pair can be coded at both ends with a knot, tape, or other device. The coded wires can then be used for identical connections. As an example, the coded wires may be connected between the "common" terminals of each speaker, and the common or ground terminals of their amplifiers. The uncoded wires may then be connected between the remaining speaker terminals and the recommended impedance tap on the amplifiers. This procedure will normally insure correct speaker phasing if the speakers and amplifiers are identical.

Speaker placement cannot be determined by fixed rule. Generally, it is better to place speakers symmetrically in relation to corners to avoid unbalanced wall reflections. For rectangular rooms, speaker placement usually seems best along a short wall.

Spacing between speakers depends entirely upon room size and listening distance. Wide spacing does not necessarily produce the so-called "hole in the middle", but may merely spread the sound further. A good compromise should be determined by experiment in order to achieve the most natural-sounding spread. Although they may be placed flat against the wall, some experiment with angling of the speakers may be rewarding. Sometimes the best effect can be secured by directing or beaming the sound from both speakers so as to cross in front of the listening area.

OPERATION

Before switching on for the first time turn the VOLUME control fully down (counter-clockwise). In addition, make sure that the controls are in their normal or centered positions. (All the lever switches should be lined up in the center position, Tone controls adjusted to the dot above each knob, Balance control to "Normal".)

1. **Slide Power Switch to "ON"**. Allow 30 seconds or so for warmup. Associated components connected to the AC outlets on the rear will also turn on.
2. **Turn SELECTOR to desired program**. To play a tape recorder, simply depress the first lever to the "TAPE" position. This lever must be returned to "SELECTOR" position in order to hear material other than tape.
3. **Set MODE to desired mode of operation** (Stereo, Channel A. etc.)
4. **Turn VOLUME clockwise to comfortable listening level.**

PHASING AND SYSTEM BALANCE

It can't be emphasized too strongly that the system connections must be *correctly phased* (identically polarized) for proper stereo effect. It should be possible to clearly pinpoint the apparent position of each instrument in the space between the loudspeakers. Out-of-phase connection results in odd directional effects which can best be described as "confusing".

PHASING OF LOUDSPEAKERS

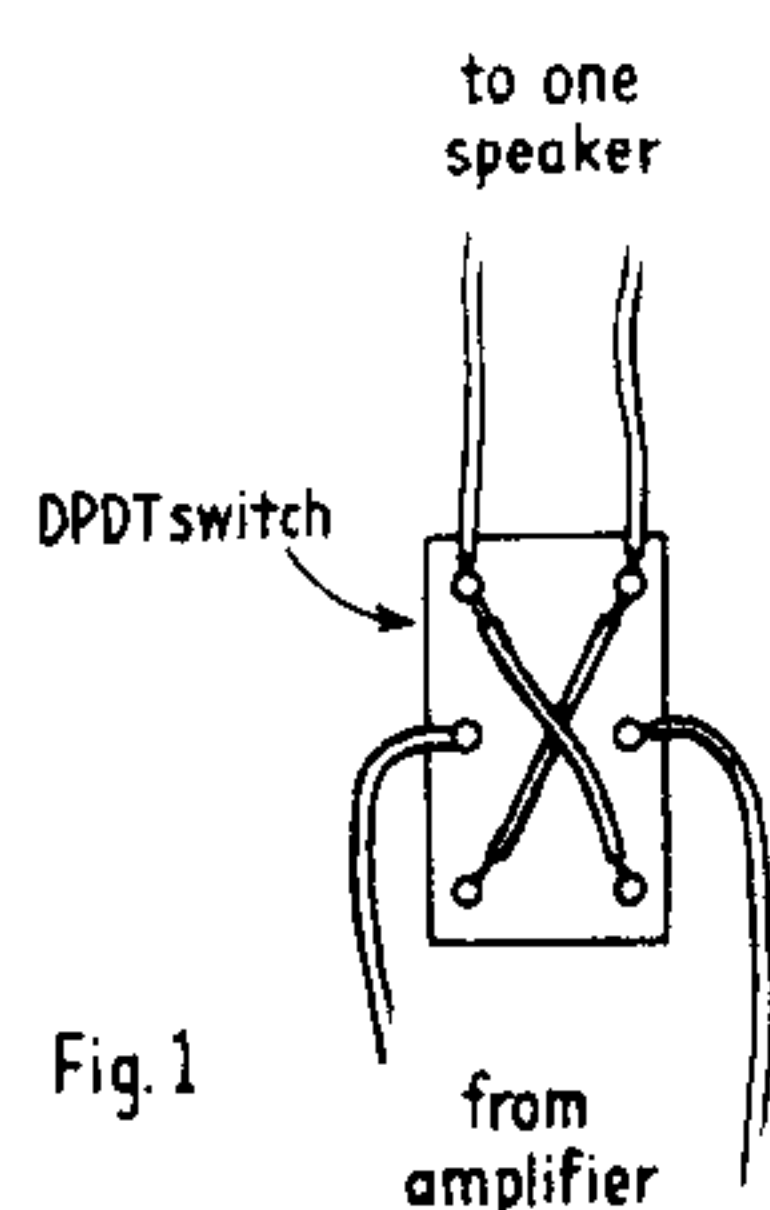

Here is a simple and very positive method of determining loudspeaker phasing.

1. Move the two speakers alongside each other as closely as possible, and away from corners.
2. Play a monophonic disc or tape which has good low frequency content.
3. Set MODE switch to a monophonic channel or to A + B.
4. Rotate the BALANCE control alternately between "Normal" and one extremity, thereby cutting one speaker in and out. If the phase is wrong, there is a marked decrease in low bass response when the Balance is in the "Normal" position, reappearing as one speaker is attenuated. In this case, reverse the leads to one speaker only. When speakers are properly phased the bass response will remain good regardless of BALANCE setting. The above effect can be accentuated by turning bass controls to maximum boost and the treble controls to minimum.

A Simple phase-reversal switch can be wired as shown in fig. 1 in the leads to one speaker. It will help in determining correct phasing and may be retained in the circuit if desired.

BALANCING OF SPEAKERS & AMPLIFIERS

1. Replace the speakers to their proper places and return Tone Controls to their normal settings.

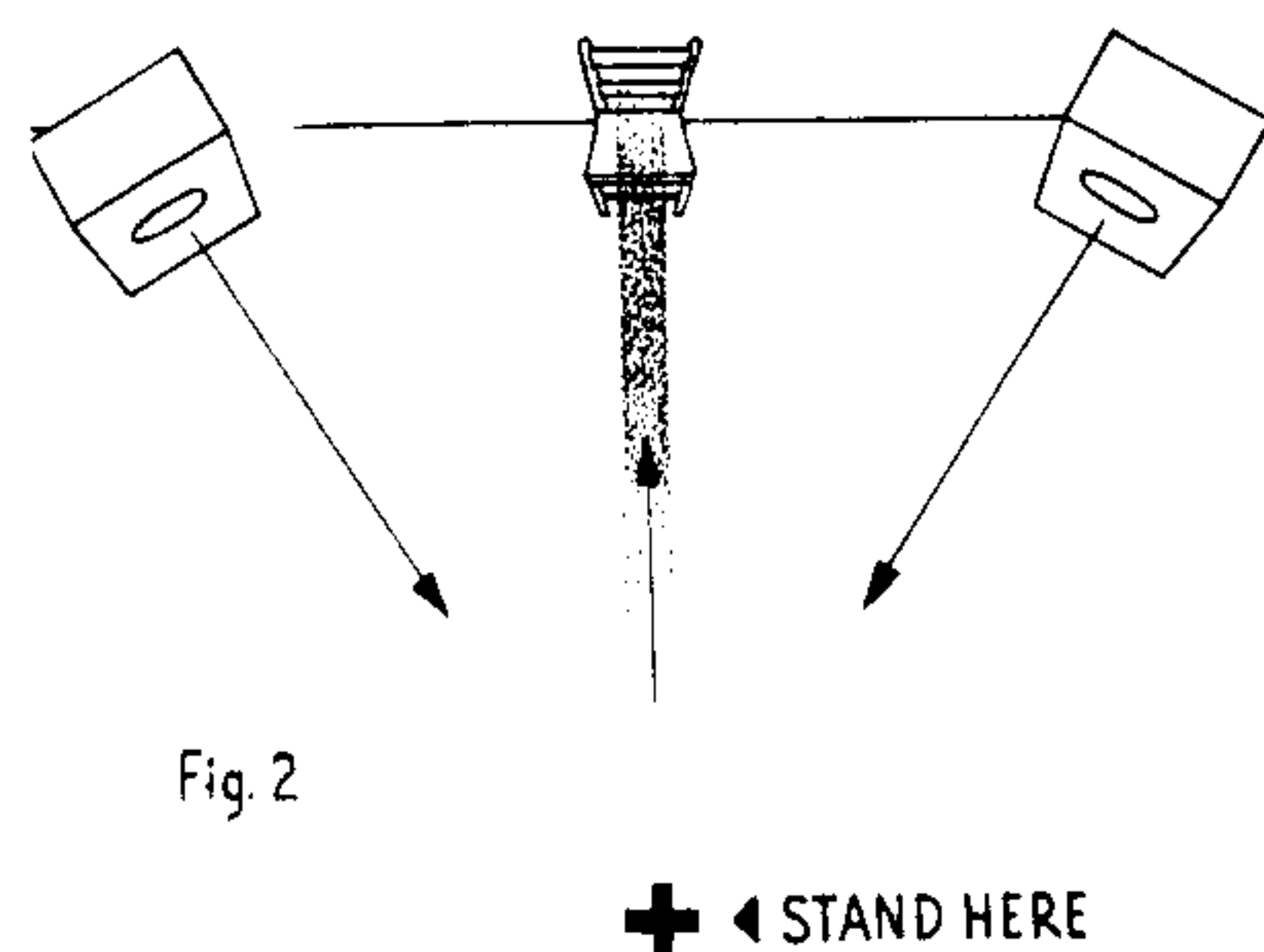

2. After removing any connection to the Microphone input, turn SELECTOR to "MICROPHONE" position, MODE to "Channel A", BALANCE to "Normal", and rear panel output levels fully clockwise for maximum output.*
3. Turn up VOLUME control until a hissing sound is clearly heard. (This noise is accentuated when there is nothing connected to the inputs)
4. Stand before the speakers facing a point midway between them. (Fig. 2)
5. When the system is balanced the sound should appear to come from the exact mid-point between the speakers. Since the apparent source will shift toward the speaker which is loudest, it can be centered if necessary by reducing the level of that channel with adjustment of the corresponding Output Level on the rear panel.

*NOTE: Where very efficient Loudspeakers or amplifiers of high input sensitivity are used, signal-to-noise ratio can be improved by turning the Output Levels to minimum instead. In this case increase the level of the least efficient channel in order to achieve balance.

CONTROLS

MAIN CONTROLS

1. **SELECTOR:** As its name implies, this is used to select the input sources. When turned to the low level positions, correct equalization is applied automatically where required. Phono positions will receive RIAA equalization and Tape-head will be equalized to the NARTB curve.* Microphone and high level sources will be flat, or without equalization.

*NOTE: a - On the rear panel are two Tape-head equalizer adjustments which allow approximately $+6\frac{1}{2}$ db to -5 db range of departure from NARTB.

- b. - A modified NARTB curve with less bass equalization below 100 cycles is made available by depressing the "PHONO EQUALIZER" lever to the "Old Columbia LP" position. This curve is suitable for several makes of recorder, including "Viking".
2. **MODE:** The various channels and modes of operation are chosen with this control. It provides two stereo and three monophonic (monaural) positions:
 - a) "STEREO"
 - b) "Stereo Reverse" This position reverses the apparent arrangement of a musical group.
 - c) "Channel A" Channel A sources will be fed through both amplifiers and speakers.
 - d) "Channel B" Same as above but selects sources connected to Channel B inputs. An AM tuner or an additional monophonic phono cartridge may be used in this way.
 - e) "A+B" In this position both channels are effectively paralleled and mixed. Where monophonic records are to be played with a stereo phono cartridge, much cleaner reproduction is obtained by this method since the effects from undesirable vertical movement is cancelled out.
3. **VOLUME:** Both channels are controlled simultaneously. Volume control tracking will be maintained to within 2db at any point of attenuation to -65 db from maximum. Since the control is situated at the input to the high level stages there is no possibility of inadvertently overloading the following circuitry. Thus, distortion is kept to a minimum.
4. **BALANCE:** This is a full range control *which permits attenuation of either speaker to complete cut-off*. Note that in monophonic operation either speaker can be used independently. In the "Normal" position the gain of both channels of the preamplifier will be balanced. Adjustment can then be made from this point to compensate for any unbalance in program material.

LEVER CONTROLS

1. **TAPE SWITCH:** In its normal position, marked "SELECTOR", the program indicated by the SELECTOR will be heard. When the lever is depressed to the "TAPE" position, Tape Recorder playback will be heard instead.
2. **PHONO EQUALIZER:** The center position, RIAA, is correct for almost all records of the last few years, including stereo disks. Many of the earlier playback curves can be very closely approximated with minor adjustment of the TONE CONTROLS. The "Old Columbia LP" position should be used with those earlier LP discs which were recorded to this curve.
3. **LOW FREQUENCY FILTER:** Its three positions include 50 cycles, 100 cycles, and OFF (normal). This filter is very useful for reducing turntable rumble or other low frequency disturbances. It also serves to reduce exaggerated low frequency response or "boominess".
4. **HIGH FREQUENCY FILTER:** Three positions of cutoff include 5kc, 9kc, and OFF. The filter will sharply reduce noise and distortion content above these frequencies without affecting the range below cutoff. For example, excessive tape hiss can be reduced to a more acceptable level by using the 9kc position, and old "scratchy" records can be helped with the 5kc position.

BASS AND TREBLE CONTROLS

These are switched feedback controls, and of an unusual type. A careful examination of the "family" of curves will reveal that they are ideal for either tonal correction or loudness compensation.

TONE CONTROL: As tone controls, these provide accurately controlled steps of increase or decrease in the bass and treble extremes. Notice that the inflection points were designed in such a manner that midrange tonal balance is not upset.

- a) Independent controls for each channel permit individual adjustment.
- b) Bass controls operate in steps of 3db as measured at 50 cycles.
- c) Treble controls operate in steps of $2\frac{1}{2}$ db as measured at 10kc.
- d) Steps provide accurately matched curves for both channels.
- e) Flat or normal positions (indicated by dot above each knob) *switch reactive tone components completely out of the circuit*, thus providing flat feedback operation.

LOUDNESS COMPENSATION: By use of the Bass controls alone, the normal range of listening levels can be very closely compensated for differences in the Fletcher-Munson loudness contours. Treble emphasis may be added if desired.

GENERAL DATA

Overall Gain (with Balance at "normal") — Phono @ 1KC . . . 64½ db; Tape Head @ 500 cps . . . 64½ db; Microphone . . . 62 db; High level . . . 22½ db (25 db max. either channel with Balance adjustment).

At Recording Output, Phono . . . 42 db; Tape-head . . . 42 db; Microphone . . . 40 db; High-level . . . Unity (0 db)

Frequency Response — Within ½ db from 20 cps to 20 kc.

IM Distortion — 10 volts equ. peak RMS, 0.15% max.

Total Noise — In 20 cps to 20 kc audio range, 80 db below 10 mv phono input with RIAA curve. Hum is far below thermal noise.

Dimensions — Chassis; 14¾" W. x 5¾" H. x 8½" D; Panel. 15¾" W. x 5¾" H; cutout dimensions: 14⅞" x 5⅞"

Tubes — 6 — ECC83/12AX7

BASS AND TREBLE CONTROLS

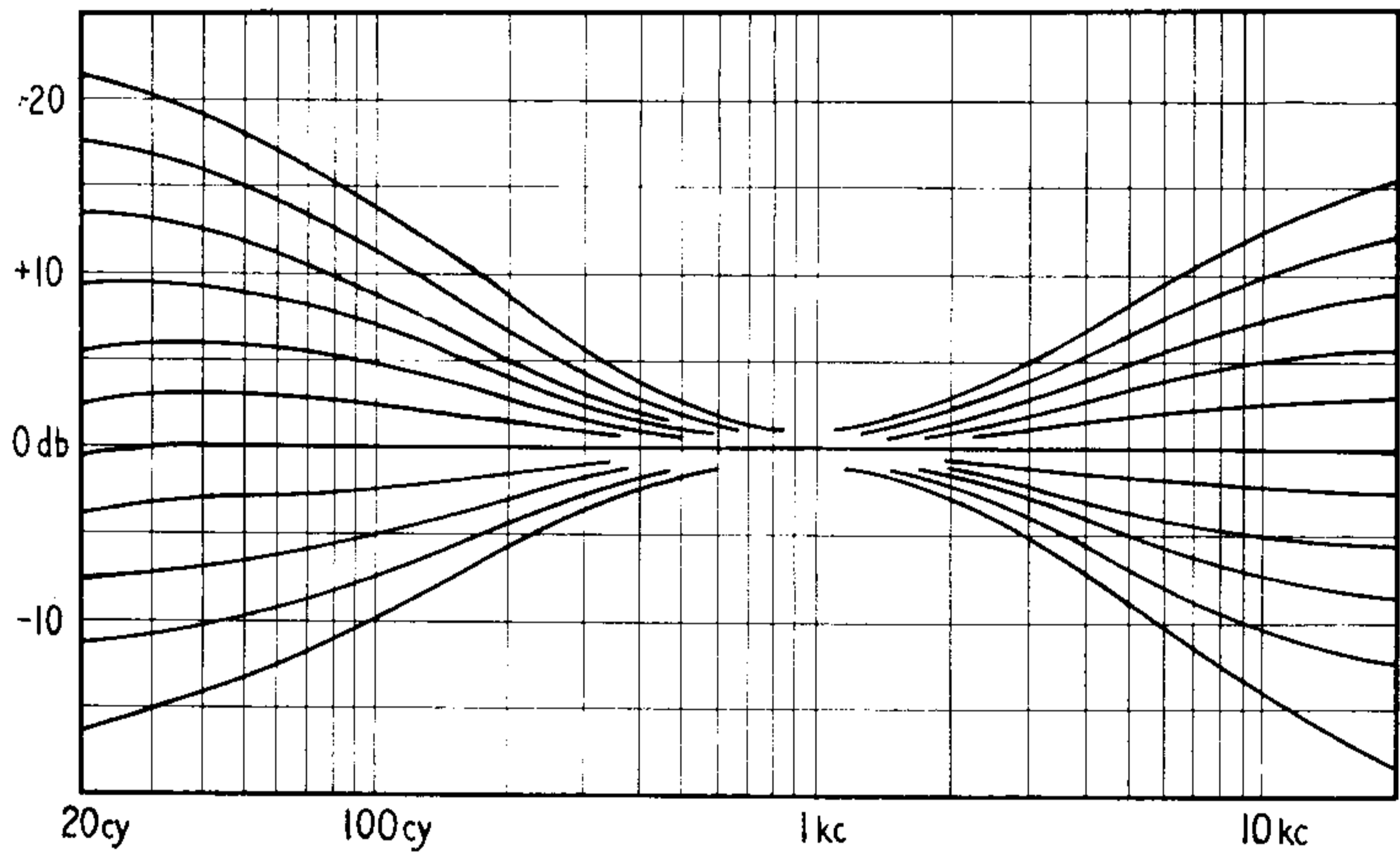

EQUALIZATION CURVES

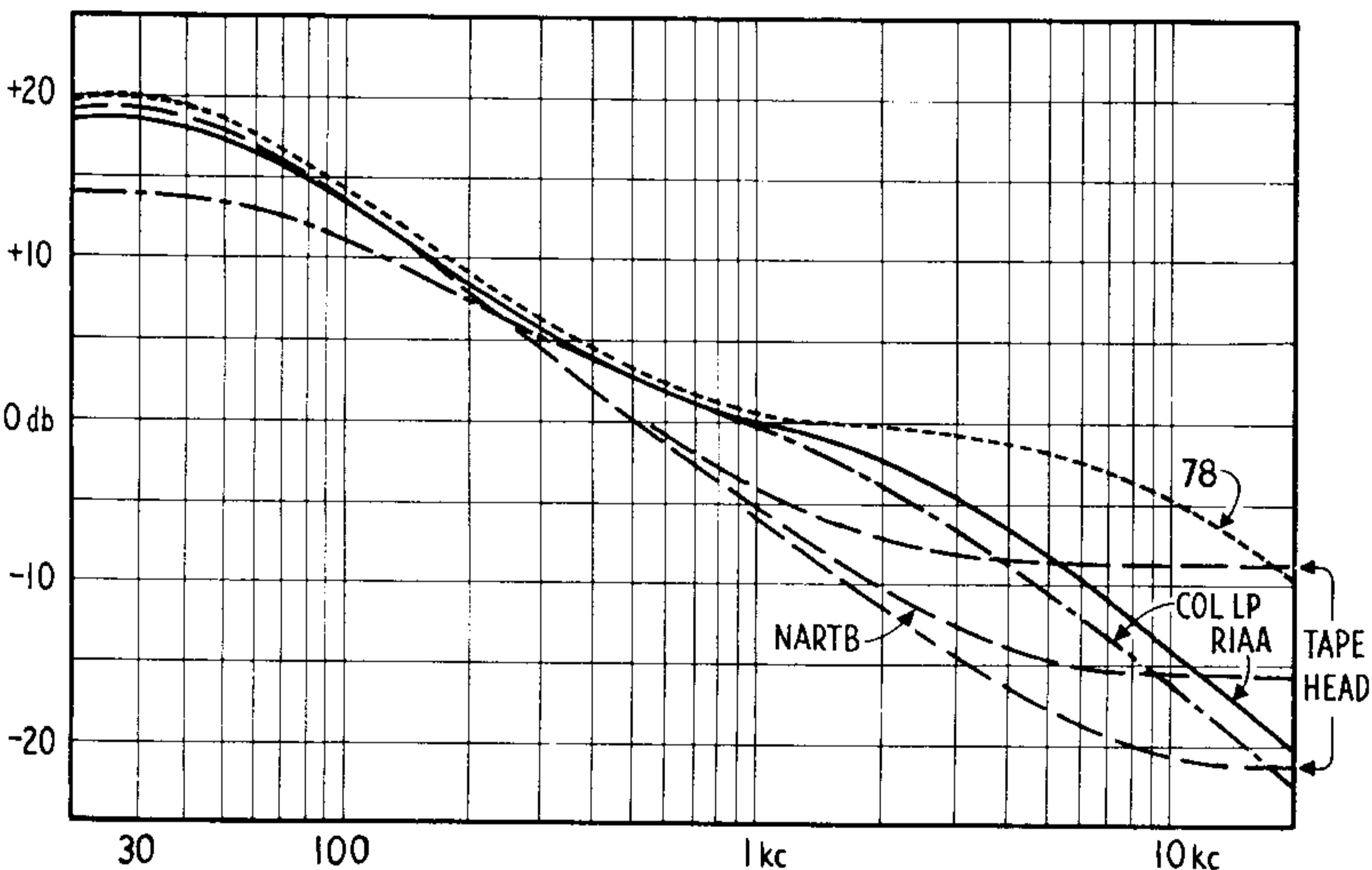

LOW AND HIGH FILTERS

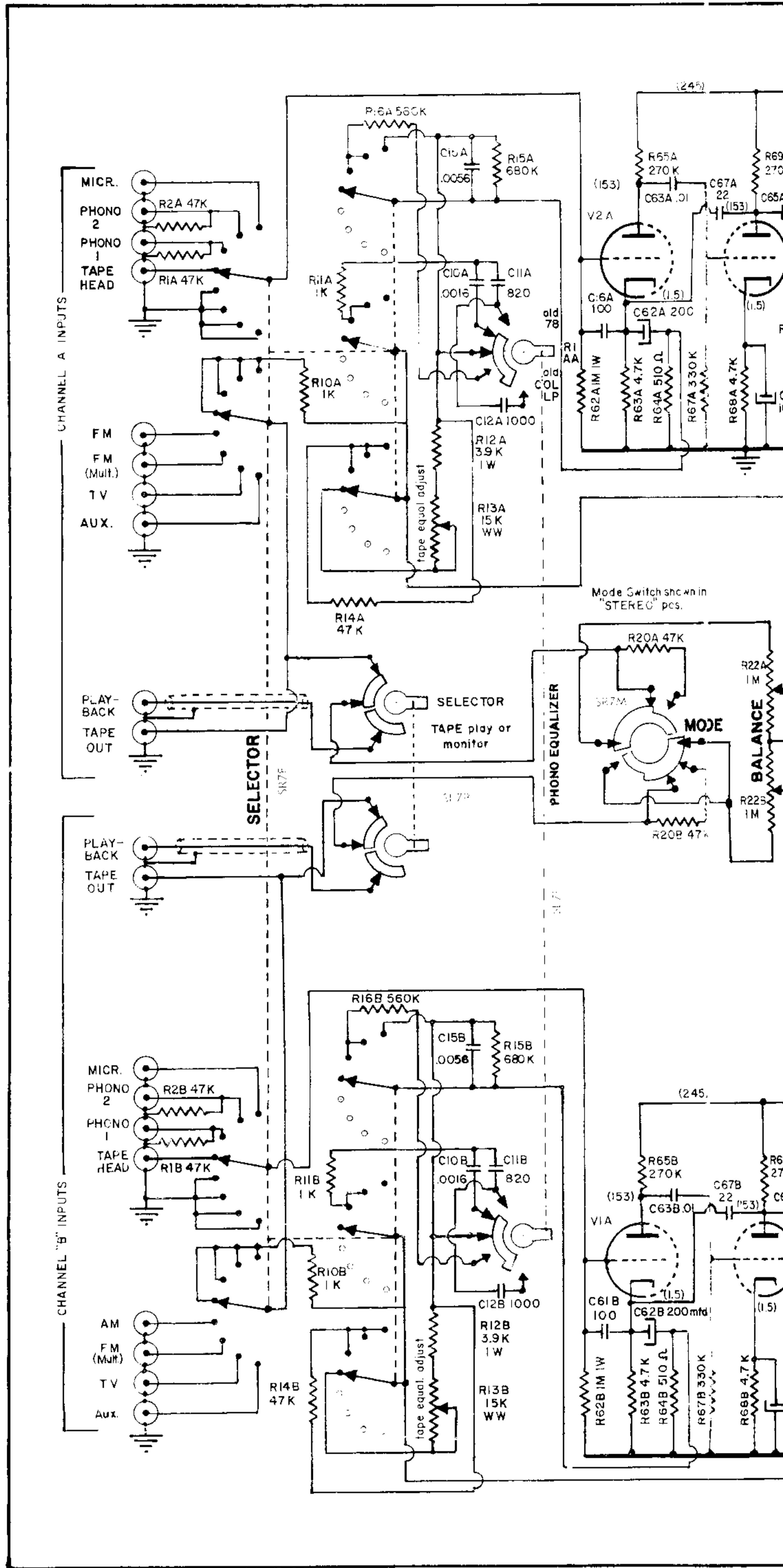
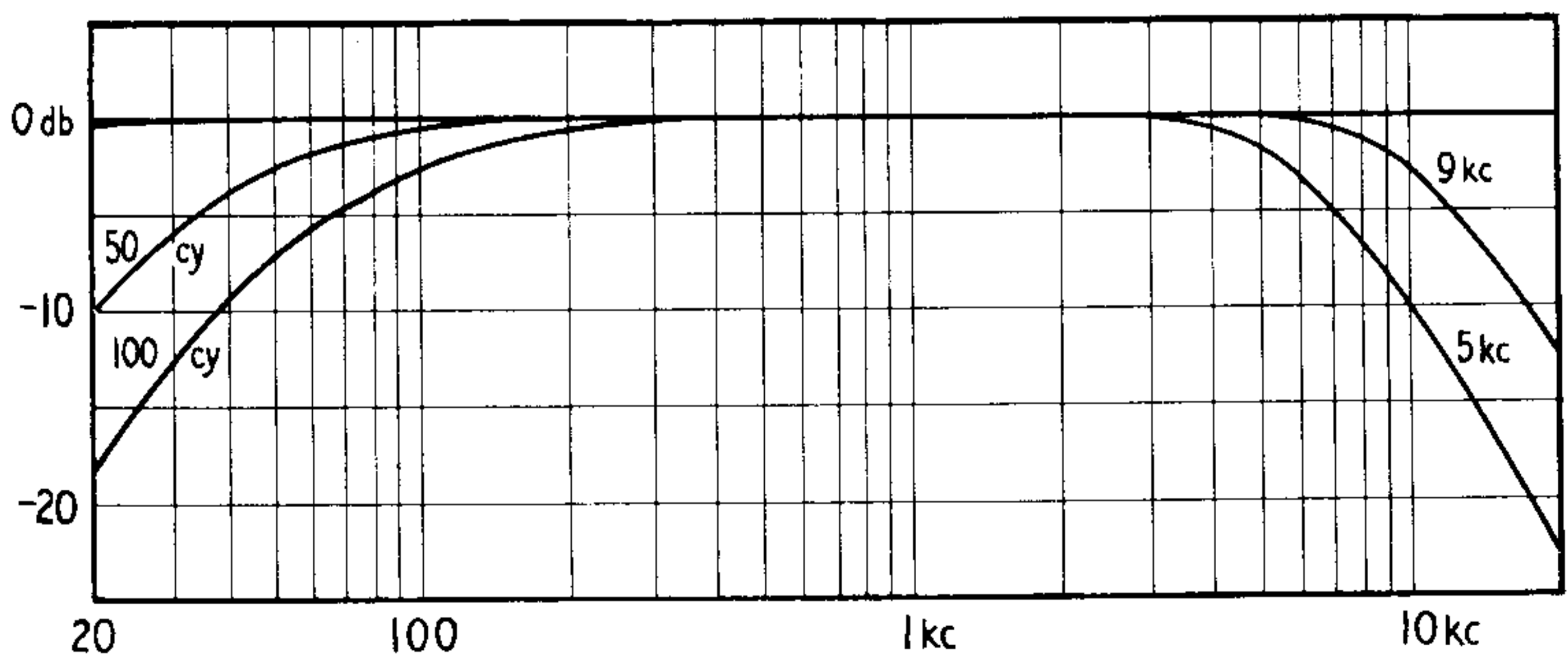

marantz Stereo Model 7

marantz comp
25-14 BROADWAY, LONG ISLAND CITY

April 1959

