

FM FRONT END UNIT

AM/FM IF & MPX UNIT

PRE AMP & RELAY UNIT

PROTECTOR & METER UNIT

TONE AMP UNIT

TR401A, 403A, 405A, 406A 2SC1222
TR402A, 404A 2SA750

TR 501A, 502A 2SA750(1) TR 505A, 508A 2SB630 TR 507A 2SD610 TR 509A
TR 503A, 504A 2SC1507 TR 506A 2SD400P TR 513A 2SA916 TR 514

R CHANNEL
(SAME AS L CHANNEL)

R CHANNEL
(SAME AS L CHANNEL)

- FM IN 2
- FM IN 1
- AM
- MAIN IN
- PRE OUT
- TAPE IN 2
- TAPE IN 1
- TAPE OUT 1
- TAPE OUT 2
- PHONO 2
- PHONO 1
- PHONO 2
- PHONO 1
- TAPE IN 1
- TAPE IN 2
- TAPE OUT 1
- TAPE OUT 2
- PRE OUT
- MAIN IN

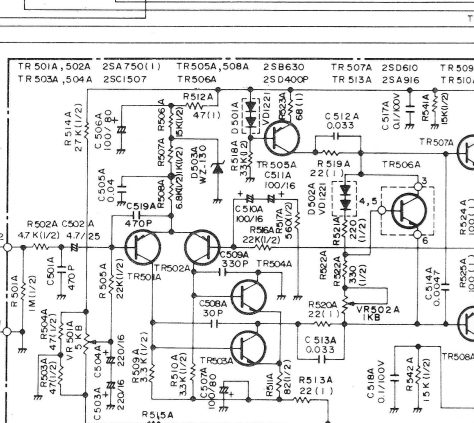
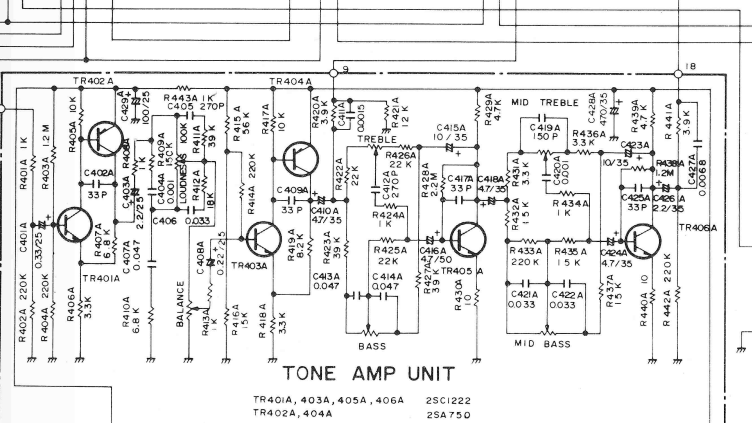
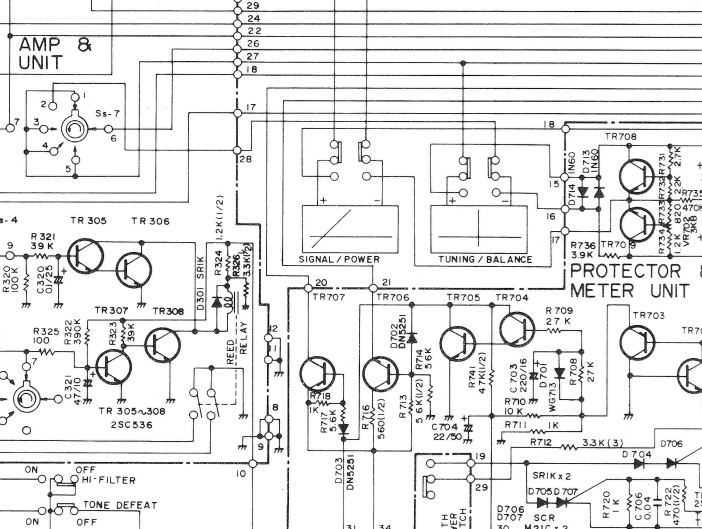
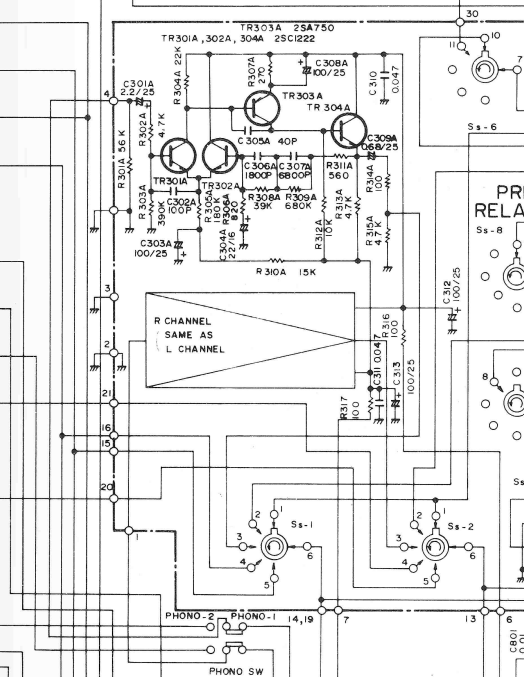
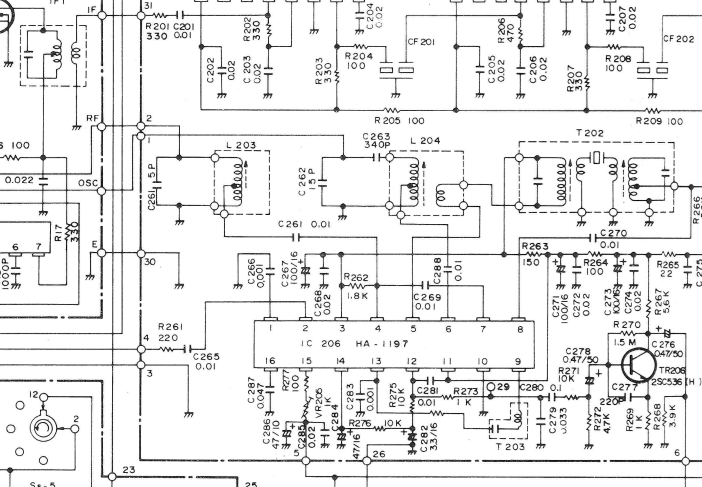
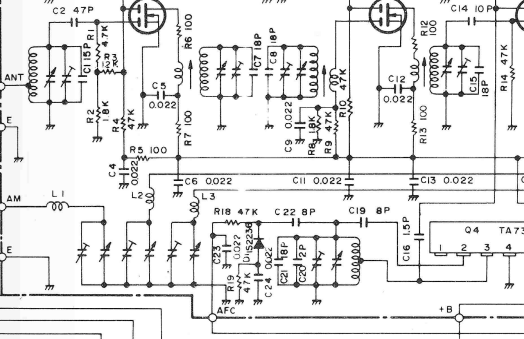

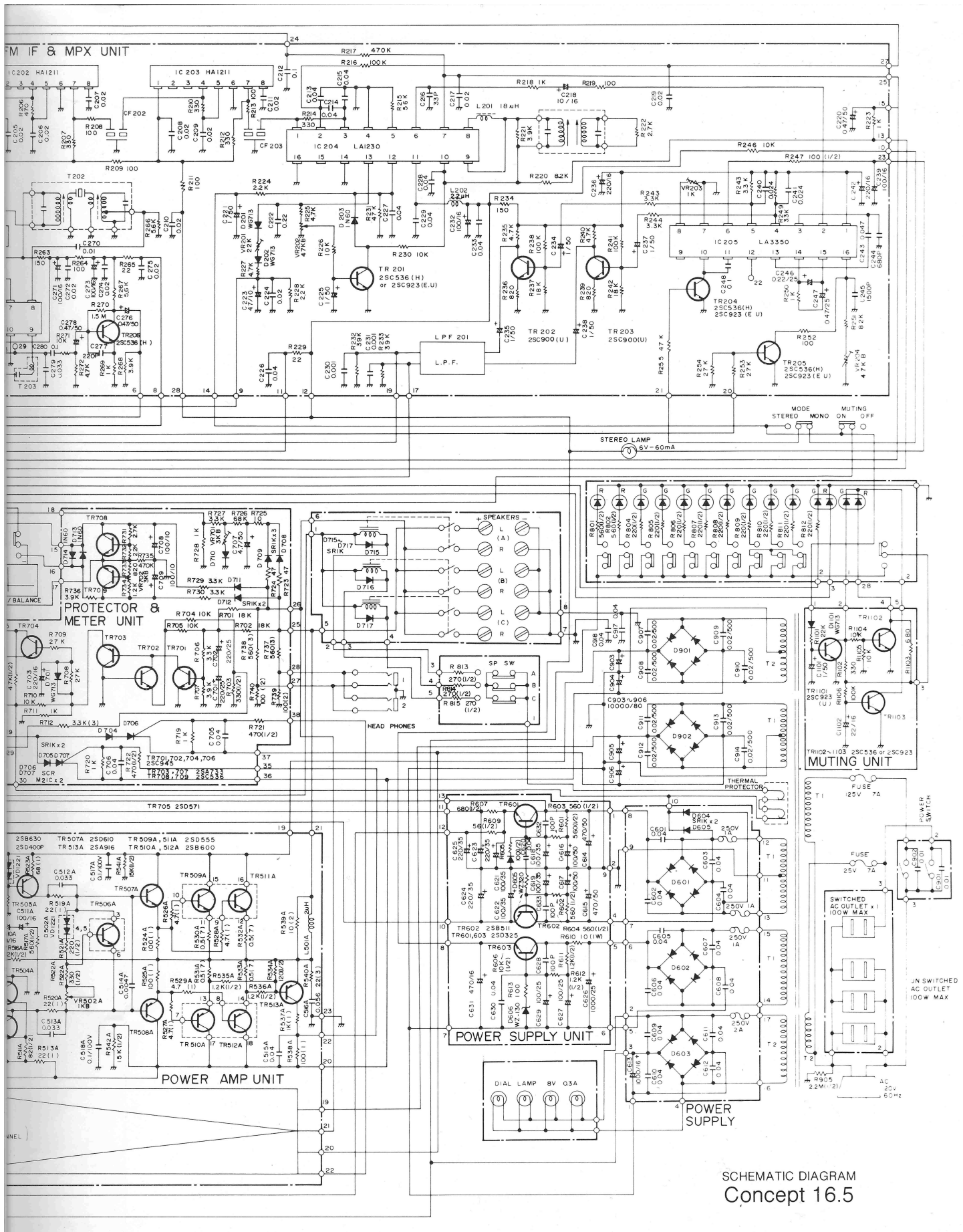

SCHMATIC DIAGRAM
Concept 16.5