

# CR400

**Powered Audio/Video Subwoofer**  
with MagnaGuard® magnetic shielding

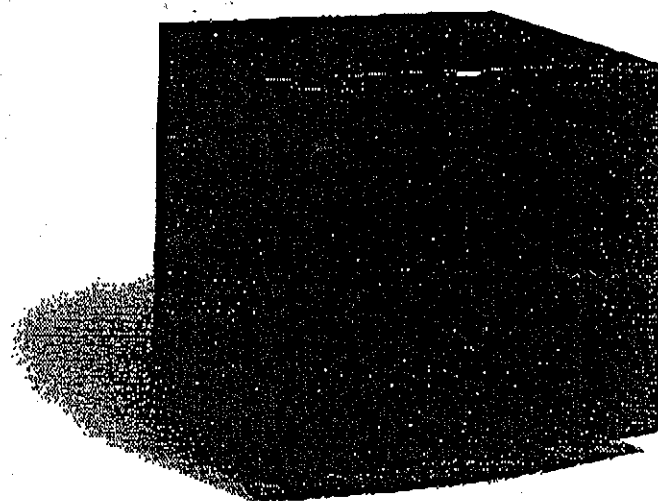

**Boston** *Acoustics*

# Safety Instructions



**Warning:** To reduce the risk of fire or electric shock, do not expose this appliance to rain or moisture.



The lightning flash with arrowhead symbol, within an equilateral triangle, is intended to alert the user to the presence of uninsulated "dangerous voltage" within the product's enclosure that may be of sufficient magnitude to constitute a risk of electric shock to persons.



The exclamation point within an equilateral triangle is intended to alert you to the presence of important operating and maintenance (servicing) instructions in the literature accompanying the appliance.

1. **Read Instructions:** All the safety and operating instructions should be read before the appliance is operated.
2. **Retain Instructions:** The safety and operating instructions should be retained for future reference.
3. **Heed Warnings:** All warnings on the appliance and in the operating instructions should be adhered to.
4. **Follow Instructions:** All operating and other instructions should be followed.
5. **Water and Moisture:** The appliance should not be used near water—for example, near a bathtub, washbowl, kitchen sink, laundry tub, in a wet basement, or near a swimming pool, etc.
6. **Carts and Stands:** The appliance should be used only with a cart or stand that is recommended by the manufacturer.
7. **Wall or Ceiling Mounting:** The appliance should not be mounted to a wall or ceiling.
8. **Ventilation:** The appliance should be situated so that its location or position does not interfere with its proper functioning. For example, the appliance should not be situated on a bed, sofa, rug or similar surface that may obstruct the heat sink surfaces; or placed in a built-in installation, such as a bookcase or cabinet that may impede the flow of air near the heat sink surfaces.
9. **Heat:** The appliance should be situated away from heat sources such as radiators, stoves, or other appliances that produce heat.
10. **Power Sources:** The appliance should be connected to a power supply only of the type described in the operating instructions or as marked on the appliance.
11. **Power Cord Protection:** Power supply cords should be routed so that they are not likely to be walked on or pinched by items placed upon or against them. Pay particular attention to cords and plugs, convenience receptacles, and the point where they exit from the appliance.
12. **Cleaning:** The appliance should only be cleaned as recommended by the manufacturer.
13. **Non-Use Periods:** The power cord should be unplugged from the outlet when left unused for long periods of time.
14. **Object and Liquid Entry:** Care should be taken so that objects do not fall into and liquids are not spilled into the inside of the appliance.
15. **Damage Requiring Service:** The appliance should be serviced if any of the following events occur:
  - A. The power supply cord or the plug has been damaged;
  - B. Objects have fallen, or liquid has been spilled into appliance;
  - C. The appliance has been exposed to rain;
  - D. The appliance does not appear to operate normally or exhibits a marked change in performance; or
  - E. The appliance has been dropped, or the enclosure damaged.
16. **Servicing:** The user should not attempt to service the appliance beyond what is described in the operating instructions. For all other servicing, consult your dealer or contact Boston Acoustics.

## Specifications

Frequency Response ( $\pm 3\text{dB}$ )	35-150Hz
Subwoofer Amplifier Power	75 watts Continuous $4\Omega$ ; < 15% THD @ 60 watts, $4\Omega$ , 25-200Hz
Subwoofer Crossover	-3dB point variable from 50-150Hz, 24dB/octave roll-off
Bass Unit	8" (200mm) copolymer with butyl rubber surround
Dimensions (HxWxD)	14 $\frac{3}{4}$ x 14 $\frac{1}{2}$ x 15 $\frac{3}{8}$ " (375 x 368 x 391mm)
Weight	35lbs. (16kg)
Finish	Black ash vinyl veneer

## Description

The CR400 subwoofer is designed to enhance the low-frequency output of stereo and home theater systems by extending the bass response of the system, enabling the entire system to play louder and clearer.

Boston Acoustics' engineers designed the CR400 to reproduce the deep fundamental tones of classical and rock music and to withstand punishment from special movie sound effects, such as explosions and punches.

The CR400 can augment a conventional stereo system with a pair of full-range main speakers. Its built-in low-pass filter has been carefully optimized to integrate the subwoofer with full-range speakers, where the outputs overlap in frequency. A switch enables the correct matching of polarities between the subwoofer and the main speakers.

The heart of the CR400 is a carefully optimized 8-inch (200mm) woofer in a cabinet with a rear vent. Both ends of the dual 2-inch (50mm) diameter vents are flared to reduce audible turbulence. The Boston-built long-throw woofer includes a high-rigidity, high-density copolymer cone and a reinforced steel frame. The driver employs our DCD™ (Deep Channel Design) technology. This relies on a deeply grooved pole plate that enables the voice coil to travel further than conventional designs permit. The increase in linear movement, known as "excursion," allows the driver to move an extremely large volume of air. The resulting bass response is deep and controlled. DCD also boasts exceptionally high power-handling and low distortion, evident in dynamic bass material.

CR400 owners have two hook-up choices: line-level and speaker-level connections. A built-in variable 4-pole lowpass filter limits the upper range of the subwoofer, with a 24dB/octave roll-off. This sharp roll-off prevents localizability of the subwoofer, increases the placement options and allows better blending with the main speakers. A switch enables the polarity of the subwoofer and main speakers to be optimally matched.

Drive power comes from a Boston-designed 75-watt amplifier, built to endure continuous duty in a movie sound system. It boasts discrete output transistors that are properly cooled and resist overloading.

The CR400 includes a defeatable automatic turn-on feature that powers up the amplifier when an input signal is presented. The subwoofer turns off the power amplifier if no signal is presented for 15 minutes.

**NOTE:** Power is always supplied to the subwoofer electronics, even when it is switched off, unless it is unplugged. The auto-on circuitry only activates or deactivates the power amplifier.

## Connections

**Line level:** Use the *line level in* with most systems. These inputs accept either left and right channel pre-amp outputs or a single subwoofer output. The CR400's circuitry filters out the high frequencies and sends the remaining low frequencies to the subwoofer power amplifier.

**Speaker level:** Use these high-level terminals with systems that do not have subwoofer or pre-amp outputs. The inputs accept both left and right channel speaker signals. The speaker level in terminals are connected directly to the speaker output terminals of the receiver, for hook-up of the left and right main speakers.

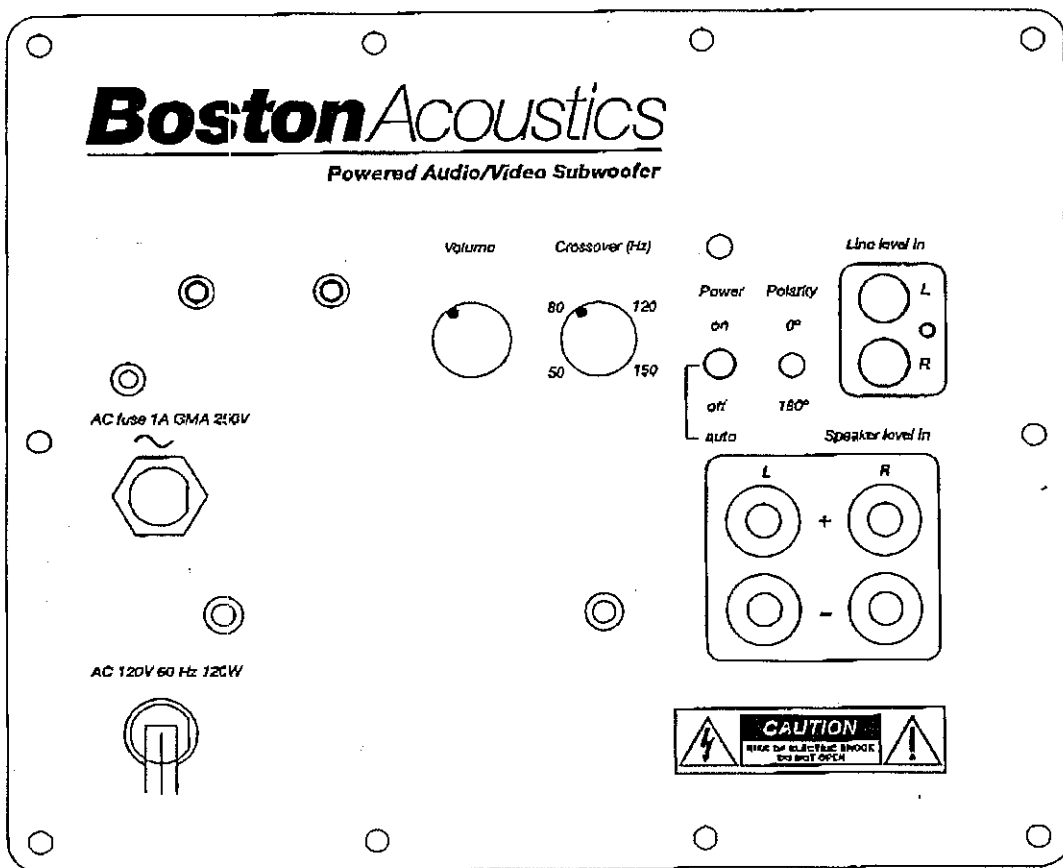

## Controls

**Volume:** Adjusts the sound level of the subwoofer. A typical setting is around 10 o'clock.

**Crossover (Hz):** Adjusts the frequency of the low-pass filter for the subwoofer from 50Hz to 150Hz.

**Polarity (0° or 180°):** Selects regular (0°) or inverted (180°) polarity for the subwoofer. Set this switch to provide the fullest, most dynamic bass. The distinction of phase will be most audible on low-frequency percussion instruments or music with a continuously repeating bass line.

**Power off/auto/on:** Set to *auto*, and the subwoofer turns on automatically when a signal is presented to it. Set to *on*, and the subwoofer will stay on all the time.

The subwoofer turns off the power amplifier, with the switch in the *auto* position, if no signal is present for 15 minutes.

**NOTE:** Power is always supplied to the subwoofer electronics, even when it is switched off, unless it is unplugged. The auto-on circuitry only activates or deactivates the power amplifier.

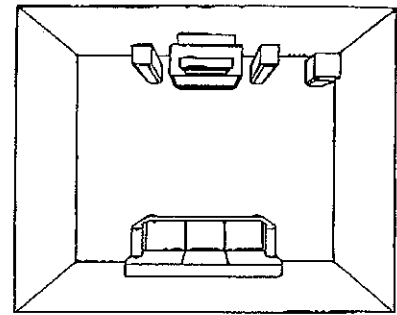

Corner placement produces the most bass.

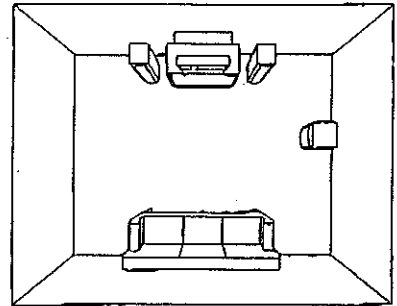

This subwoofer can be placed away from the main speakers.

## Placement

Place the subwoofer next to a wall or in a corner near your main speakers. Typically, the sound is best when the subwoofer is within 15 feet (5m) of the main speakers. However, the sharp crossover roll-off permits placement farther from the main speakers if necessary. Since the ear is unable to localize the low frequencies of the subwoofer, the bass still appears to come from the main speakers. In most cases, the subwoofer may be placed anywhere in the listening room.

The level of bass output from the subwoofer will vary at different positions in a room. When placed near walls, its loudness is emphasized. Corner placement provides the most bass output, while placement near only one wall will provide somewhat less bass. Placement completely away from walls may produce too little bass. Regardless of how you place the subwoofer, you can adjust the subwoofer's level with its rear panel level controls. If you move the subwoofer, recheck the setting of the polarity switch. Use the setting that yields the louder and more dynamic sound.

**IMPORTANT:** Do not place the subwoofer where there is a chance of contact between the rear panel heat sinks and drapes or furniture. Avoid obstructing air flow to the back.

## General Guidelines on Wiring

The subwoofer may be wired to your system via either line-level (before the power amplifier) or speaker-level (after the power amplifier) connections.

**When to use line-level connections:** As a general rule, the best results come from using the line level connections, where sound is passed from the preamplifier's outputs to the subwoofer. Many receivers and integrated amplifiers include "preamp out" RCA jacks on the back panel. You may use outputs labeled "preamp out" or "sub out." Either may be connected to the subwoofer's line-level inputs.

**When to use speaker-level connections:** Some receivers do not provide access to the preamplifier, after the volume control and before the main power amplifier. In these cases, use the speaker-level connections. You may also prefer to use the speaker-level connections if the speakers and subwoofer are in a different room from the receiver or amplifier.

## Fine-Tuning a System

**Polarity adjustment:** Use the polarity switch to match the polarity (sometimes referred to as "phase") of the main speakers and the subwoofer. Try both switch positions and use the one that gives the fullest and most dynamic bass. The distinction of phase will be most audible on low-frequency percussion instruments or music with a continuously repeating bass line.

**Frequency adjustment:** The subwoofer will reproduce sound below the frequency selected on the crossover frequency control. Generally, it is best to start with the knob adjusted to about 120Hz. You may find you prefer the sound with the subwoofer adjusted to a lower frequency. If so, try setting the control to the specified low-frequency limit (-3dB point) of the main speakers. When adjusting the crossover frequency control, always experiment with the polarity switch and the volume control.

## Line-Level Connections

**Preamp out and sub out:** The listener may wish to use only the *preamp out* or the *sub out* or *low pass out* from a receiver. Any of these may be connected to the *line level in* jacks on the subwoofer. In this situation, the main speakers will continue to play the full range of sound.

The preferred method of connecting the subwoofer is to use a stereo RCA cable connected to the line level, left and right front outputs from the receiver or preamplifier. Some receivers and integrated amplifiers provide access to the preamp/amp link using jumper wire connections labeled "preamp out" and "amplifier in."

The line-level circuit of the subwoofer takes the signal (from the "in" jacks) and extracts the bass.

**NOTE:** In surround sound systems, the subwoofer should be wired to connections for the front left and right channels. If you are using a center channel speaker with a Dolby® Pro Logic® system, set the Center Channel Mode to NORMAL. This will send all the bass to the left and right channels and thus to the subwoofer.

**Option 1—Receiver or integrated amp systems with a pre-amp output:** If your receiver has a pre-amp out jack, use a stereo RCA cable to connect your system's pre-amp out jacks to the line level in jacks on the subwoofer.

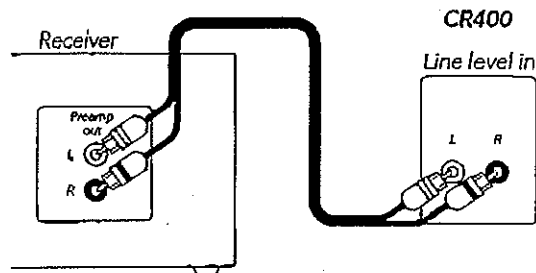

**Option 2—Using a "sub out" connection:** Use an RCA cable to connect your system's sub out jack to one of the line level in jacks on the subwoofer. If your system lets you switch the sub out jack between a flat response or low-frequency-only signal, use the flat-response setting.

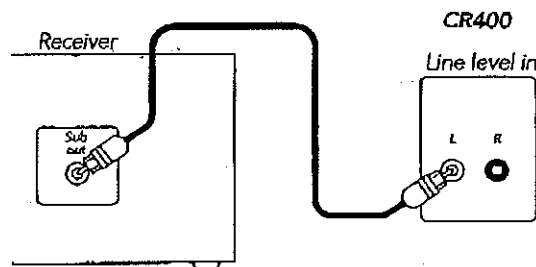

## Speaker-Level Connections

The simplest way to wire the subwoofer is via speaker connections. Wired in this way, the subwoofer does not present any additional load to your amplifier. There are three ways to wire the subwoofer to your speaker connections; each way produces the same result. You may want to use long wires to the subwoofer at first so you may experiment with placement.

As a general rule, it is best to keep the total length of wire between the amplifier and your main speakers as short as possible. The subwoofer, on the other hand, is not sensitive to wire length.

Be sure to connect + to + (positive) and – to – (negative) by using the markings on the wire.

**WARNING:** To reduce the risk of electrical shock, always switch off the subwoofer and the amplifier and/or receiver when making connections to the subwoofer and speakers.

**NOTE:** The subwoofer should be wired to connections for the front left and right speakers. If you are using a center channel speaker with a Dolby® Pro Logic® system, set the Center Channel Mode to NORMAL. This will send all the bass to the left and right channels and thus to the subwoofer.

**Identifying + and - connections:** Typically, one side of the wire is smooth. Connect this wire to the - (black) connectors. The other side typically has a rib or stripe. Connect this side to the + (red) connectors.

**Using the binding posts:** The binding posts permit easy connection to banana plugs, pins, and bare wire.

**IMPORTANT:** Be sure to tighten any unused binding posts. This will help prevent buzzing.

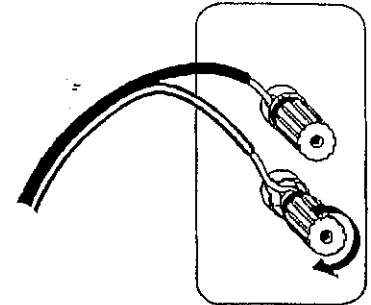

**OPTION 1:** Connect the upper set of speaker binding posts on the subwoofer to the left and right speaker outputs of your amplifier using the supplied speaker wire. Use the same speaker outputs that drive your main speakers. Do not connect the subwoofer to any other speaker outputs that may be on your amplifier.

**IMPORTANT:** When making connections, be sure to connect + to + (positive) and - to - (negative).

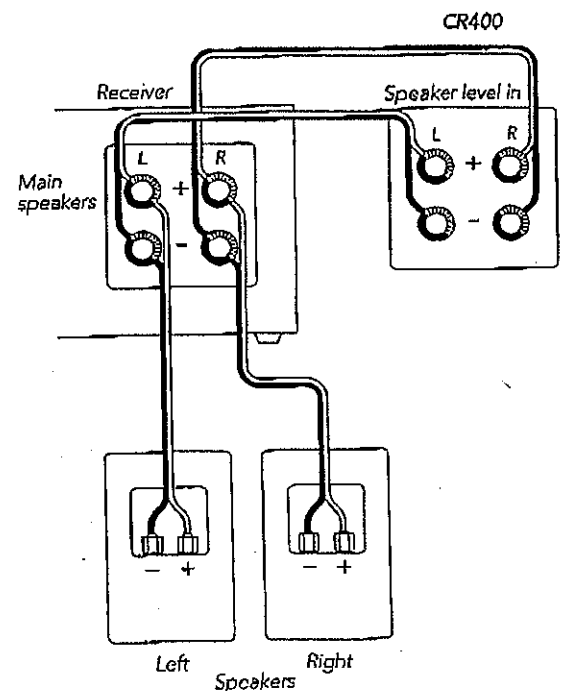

**Alternative options:** In some cases, you may find it easier to use one of the following alternative wiring plans. The resulting sound will be the same.

**OPTION 2:** Connect the upper set of speaker binding posts on the subwoofer to the left and right speaker outputs of your amplifier. Connect the lower set of speaker binding posts on the subwoofer to your left and right speakers.

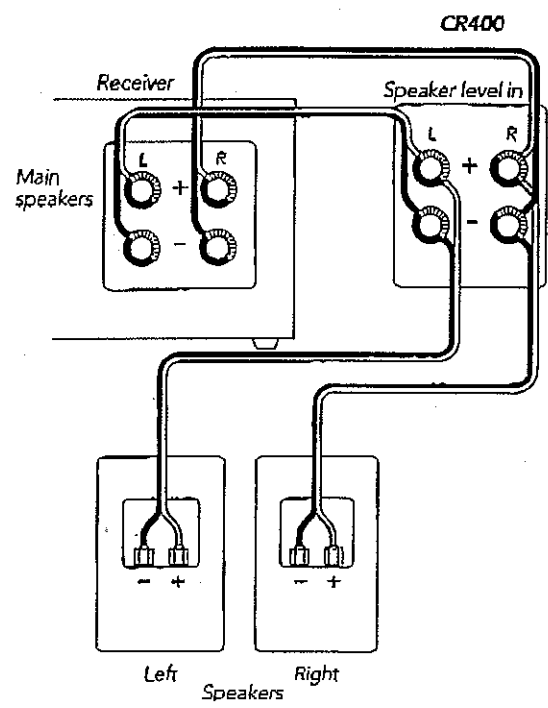

**OPTION 3:** Connect the upper set of speaker binding posts on the subwoofer to the terminals on your left and right main speakers.

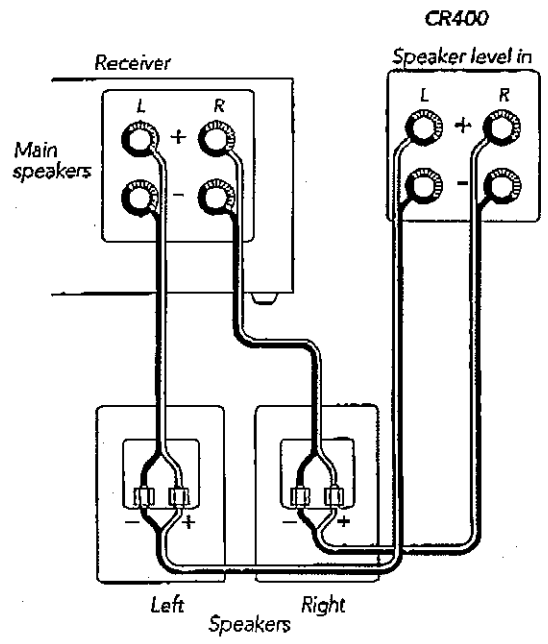

# Using Two Subwoofers

You may wish to use two subwoofers to produce more bass, particularly in a large room. Double subwoofers may be wired with either speaker-level or line-level connections. They may be both wired to the left and right channels or one may be wired to the left channel and one to the right channel, producing the so-called "stereo bass." However, there is no real stereo information at these frequencies, and wiring both subwoofers to both channels usually gives the most bass and the flattest response around the room.

**IMPORTANT:** Be sure both subwoofers are set to the same polarity. Try both settings to hear which sounds best; be sure to set them identically.

**OPTION 1—Wiring double subwoofers with RCA plug line-level connections:** Use two Y-connectors to daisy chain the "preamp out" signal to the input of a second woofer.

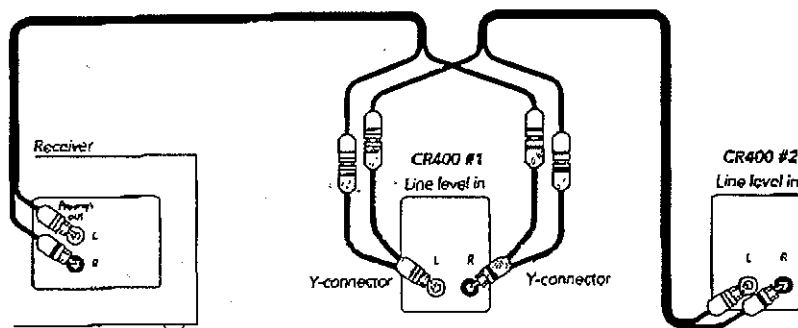

**OPTION 2—Wiring double subwoofers with speaker wire:** Use the binding posts on one subwoofer to daisy chain to the second subwoofer.

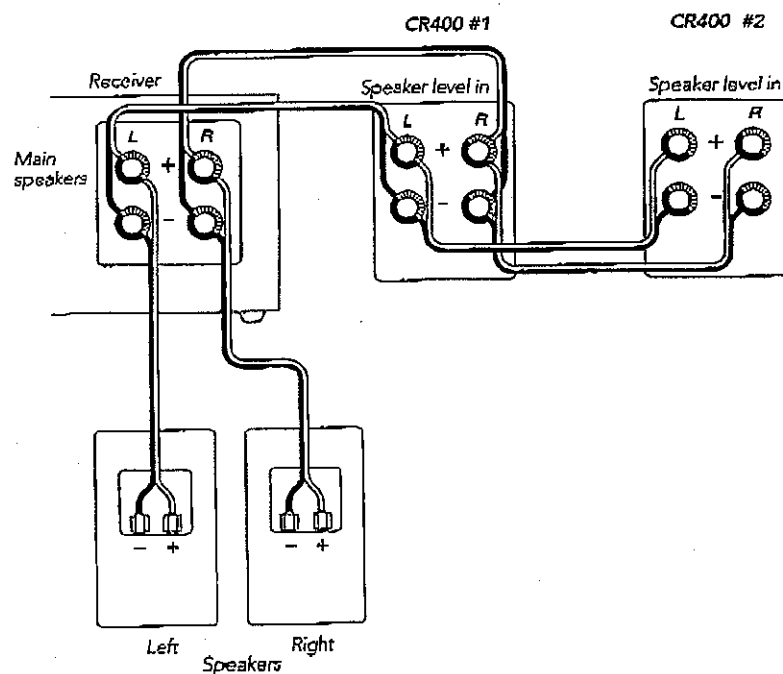

## Placement of Two Subwoofers

Place the subwoofers in the corners of the room nearest the main speakers. Your placement need not be symmetrical. Since bass is omnidirectional, you may place one subwoofer to each side, or both on one side, with equally good results.

In some instances, the flattest bass frequency response (and hence the cleanest sound) will result if one subwoofer is in a corner and the other subwoofer is near the center of one wall. This positioning counteracts the acoustical standing waves that can cause boominess.

## Troubleshooting

### • Subwoofer does not make sound

1. Check if the subwoofer's AC power cord is properly plugged in. If the outlet being used is controlled by a switch, be sure the switch is on.
2. Check if the power switch on the subwoofer is switched to either "on" or "auto-on."
3. If the power cord is properly attached but the red pilot light does not illuminate, the AC fuse may be blown. If necessary, replace the fuse with a same type fuse, or consult a service technician.

### • Subwoofer does not play loud enough

1. Put the subwoofer in a corner. Corner placement produces the most bass.
2. In a Dolby® Pro Logic® surround system, set the center channel mode to "NORMAL." This diverts movie bass from the center channel to the left and right front channels and thus to the subwoofer.
3. Set the crossover frequency to its highest setting. This will subjectively produce the loudest and most dynamic sound.
4. Try both settings of the polarity switch. Use the setting that results in the loudest sound.

### • Subwoofer has a boomy quality

A boomy sound may signify that the room has a resonance between 50 and 100Hz. This condition is exemplified by an unnatural richness in the sound of voice or acoustic instruments.

1. Try adjusting the crossover frequency lower than 100Hz to confine the subwoofer's reproduction to below the room's resonant frequency.
2. Try moving the subwoofer. Often moving the subwoofer away from a corner, or unequal distances from walls, will solve this problem.

### • Auto turn-on is not sensitive enough

If you find that the subwoofer does not turn on for quiet signals, or that it turns off too readily, set the power switch to "on." The subwoofer will stay on at all times. The power consumption is minimal.

### • Feedback on karaoke or LP records

Subwoofer feedback sounds like a loud hum. Try moving either the subwoofer or the sound source (turntable or microphone) to a different location. Do not set the microphone or turntable on a piece of furniture that is also supporting or contacting the subwoofer.

## Limited Warranty

For one year from the date of purchase, Boston Acoustics will repair for the original owner any defect in materials or workmanship that occurs in normal use of the subwoofer system, without charge for parts and labor.

Your responsibilities are to use the system according to the instructions supplied, to provide safe and secure transportation to an authorized Boston Acoustics service representative and to present proof of purchase in the form of your sales slip when requesting service.

Excluded from this warranty is damage that results from abuse, misuse, accidents, shipping, or repairs or modifications by anyone other than an authorized Boston Acoustics service representative.

*This warranty is void if the serial number has been removed or defaced.*

This warranty gives you specific legal rights, and you may also have other rights which vary from state to state.

## If service seems necessary

First, contact the retailer from whom you purchased the subwoofer. If that is not possible, write to:

Boston Acoustics, Inc., 300 Jubilee Drive Peabody, MA 01960 U.S.A.

We will promptly advise you of what action to take. If it is necessary to return your speaker to the factory, please ship it prepaid. After it has been repaired, we will return it freight prepaid in the U.S. and Canada.

***Boston Acoustics***  
300 Jubilee Drive  
Peabody, MA 01960 U.S.A.  
978.538.5000

© Copyright 1997 Boston Acoustics, Inc. All rights reserved.  
DCD is a trademark and Boston, Boston Acoustics and  
MagnaGuard are registered trademarks of Boston  
Acoustics, Inc. Dolby and Pro Logic are registered trade-  
marks of Dolby Laboratories Licensing Corporation  
Specifications subject to change without notice.  
42-604-3